



# FCC RF Test Report

APPLICANT : HMD Global Oy  
EQUIPMENT : Smart Phone  
BRAND NAME : NOKIA  
MODEL NAME : TA-1038  
FCC ID : 2AJOTTA-1038  
STANDARD : FCC Part 15 Subpart C §15.247  
CLASSIFICATION : (DTS) Digital Transmission System

The product was received on Jan. 18, 2017 and testing was completed on Feb. 18, 2017. We, SPORTON INTERNATIONAL INC., would like to declare that the tested sample has been evaluated in accordance with the test procedures and has been in compliance with the applicable technical standards.

The test results in this report apply exclusively to the tested model / sample. Without written approval of SPORTON INTERNATIONAL INC., the test report shall not be reproduced except in full.

Reviewed by: Joseph Lin / Supervisor

Approved by: Jones Tsai / Manager



## SPORTON INTERNATIONAL INC.

No. 52, Hwa Ya 1<sup>st</sup> Rd., Hwa Ya Technology Park, Kwei-Shan District, Tao Yuan City, Taiwan, R.O.C.



# TABLE OF CONTENTS

**REVISION HISTORY..... 3**

**SUMMARY OF TEST RESULT ..... 4**

**1 GENERAL DESCRIPTION ..... 5**

    1.1 Applicant ..... 5

    1.2 Manufacturer ..... 5

    1.3 Product Feature of Equipment Under Test..... 5

    1.4 Product Specification of Equipment Under Test..... 5

    1.5 Modification of EUT ..... 6

    1.6 Testing Location ..... 6

    1.7 Applicable Standards ..... 6

**2 TEST CONFIGURATION OF EQUIPMENT UNDER TEST ..... 7**

    2.1 Carrier Frequency and Channel ..... 7

    2.2 Test Mode ..... 8

    2.3 Connection Diagram of Test System ..... 9

    2.4 Support Unit used in test configuration and system ..... 10

    2.5 EUT Operation Test Setup ..... 10

    2.6 Measurement Results Explanation Example ..... 10

**3 TEST RESULT ..... 11**

    3.1 6dB Bandwidth Measurement ..... 11

    3.2 Output Power Measurement..... 13

    3.3 Power Spectral Density Measurement ..... 14

    3.4 Conducted Band Edges and Spurious Emission Measurement ..... 16

    3.5 Radiated Band Edges and Spurious Emission Measurement ..... 26

    3.6 AC Conducted Emission Measurement..... 30

    3.7 Antenna Requirements ..... 34

**4 LIST OF MEASURING EQUIPMENT ..... 35**

**5 UNCERTAINTY OF EVALUATION ..... 37**

**APPENDIX A. CONDUCTED TEST RESULTS**

**APPENDIX B. RADIATED SPURIOUS EMISSION**

**APPENDIX C. DUTY CYCLE PLOTS**

**APPENDIX D. SETUP PHOTOGRAPHS**



### REVISION HISTORY

REPORT NO.	VERSION	DESCRIPTION	ISSUED DATE
FR711304-01C	Rev. 01	Initial issue of report	Mar. 10, 2017



### SUMMARY OF TEST RESULT

Report Section	FCC Rule	Description	Limit	Result	Remark
3.1	15.247(a)(2)	6dB Bandwidth	$\geq 0.5\text{MHz}$	Pass	-
3.2	15.247(b)	Power Output Measurement	$\leq 30\text{dBm}$	Pass	-
3.3	15.247(e)	Power Spectral Density	$\leq 8\text{dBm}/3\text{kHz}$	Pass	-
3.4	15.247(d)	Conducted Band Edges	$\leq 20\text{dBc}$	Pass	-
		Conducted Spurious Emission		Pass	-
3.5	15.247(d)	Radiated Band Edges and Radiated Spurious Emission	15.209(a) & 15.247(d)	Pass	Under limit 5.01 dB at 62.130 MHz
3.6	15.207	AC Conducted Emission	15.207(a)	Pass	Under limit 13.40 dB at 13.558 MHz
3.7	15.203 & 15.247(b)	Antenna Requirement	N/A	Pass	-



# 1 General Description

## 1.1 Applicant

HMD Global Oy  
Karaportti 2, 02610 Espoo, Finland

## 1.2 Manufacturer

HMD Global Oy  
Karaportti 2, 02610 Espoo, Finland

## 1.3 Product Feature of Equipment Under Test

Product Feature	
Equipment	Smart Phone
Brand Name	NOKIA
Model Name	TA-1038
FCC ID	2AJOTTA-1038
EUT supports Radios application	GSM/GPRS/EGPRS/WCDMA/HSPA/DC-HSDPA/ HSPA+/LTE/NFC WLAN 2.4GHz 802.11b/g/n HT20/ WLAN 5GHz 802.11a/n HT20/HT40 Bluetooth v3.0 + EDR/ Bluetooth v 4.0 LE/ Bluetooth v4.1 LE / Bluetooth v4.2 LE
IMEI Code	Conducted: 356805080008438/356805080008420 Conduction: 356805080006838/356805080006820 Radiation: 356805080007877
HW Version	DVT1.5
SW Version	000C_1_26A
EUT Stage	Production Unit

**Remark:** The above EUT's information was declared by manufacturer. Please refer to the specifications or user's manual for more detailed description.

## 1.4 Product Specification of Equipment Under Test

Standards-related Product Specification	
Tx/Rx Channel Frequency Range	2412 MHz ~ 2462 MHz
Maximum (Peak) Output Power to antenna	802.11b : 18.93 dBm (0.0782 W) 802.11g : 21.99 dBm (0.1581 W) 802.11n HT20 : 22.04 dBm (0.1600 W)
Antenna Type / Gain	Loop Antenna with gain 0.75 dBi
Type of Modulation	802.11b : DSSS (DBPSK / DQPSK / CCK) 802.11g/n : OFDM (BPSK / QPSK / 16QAM / 64QAM)



### 1.5 Modification of EUT

No modifications are made to the EUT during all test items.

### 1.6 Testing Location

Sporton Lab is accredited to ISO 17025 by Taiwan Accreditation Foundation (TAF code : 1190) and the FCC designation No. TW1022 under the FCC 2.948(e) by Mutual Recognition Agreement (MRA) in FCC Test.

<b>Test Site</b>	SPORTON INTERNATIONAL INC.		
<b>Test Site Location</b>	No. 52, Hwa Ya 1 <sup>st</sup> Rd., Hwa Ya Technology Park, Kwei-Shan District, Tao Yuan City, Taiwan, R.O.C. TEL: +886-3-327-3456 FAX: +886-3-328-4978		
<b>Test Site No.</b>	<b>Sporton Site No.</b>		
	TH05-HY	CO05-HY	03CH07-HY

**Note:** The test site complies with ANSI C63.4 2014 requirement.

### 1.7 Applicable Standards

According to the specifications of the manufacturer, the EUT must comply with the requirements of the following standards:

- FCC Part 15 Subpart C §15.247
- FCC KDB Publication No. 558074 D01 DTS Meas. Guidance v03r05
- ANSI C63.10-2013

**Remark:**

1. All test items were verified and recorded according to the standards and without any deviation during the test.
2. This EUT has also been tested and complied with the requirements of FCC Part 15, Subpart B, recorded in a separate test report.



## 2 Test Configuration of Equipment Under Test

The EUT has been associated with peripherals and configuration operated in a manner tended to maximize its emission characteristics in a typical application. Frequency range investigated: conducted emission (150 kHz to 30 MHz) and radiated emission (9 kHz to the 10th harmonic of the highest fundamental frequency or to 40 GHz, whichever is lower). For radiated measurement, pre-scanned in three orthogonal panels, X, Y, Z. The worst case (X plane) was recorded in this report.

### 2.1 Carrier Frequency and Channel

Frequency Band	Channel	Freq. (MHz)	Channel	Freq. (MHz)
2400-2483.5 MHz	1	2412	7	2442
	2	2417	8	2447
	3	2422	9	2452
	4	2427	10	2457
	5	2432	11	2462
	6	2437	-	-



## 2.2 Test Mode

Final test mode of conducted test items and radiated spurious emissions are considering the modulation and worse data rates as below table.

Modulation	Data Rate
802.11b	1 Mbps
802.11g	6 Mbps
802.11n HT20	MCS0

Test Cases	
AC Conducted Emission	Mode 1 : GSM850 Idle + Bluetooth Idle + WLAN Idle + USB Cable (Charging from Adapter) + Earphone + NFC On + SIM2



## 2.3 Connection Diagram of Test System

### <WLAN Tx Mode>

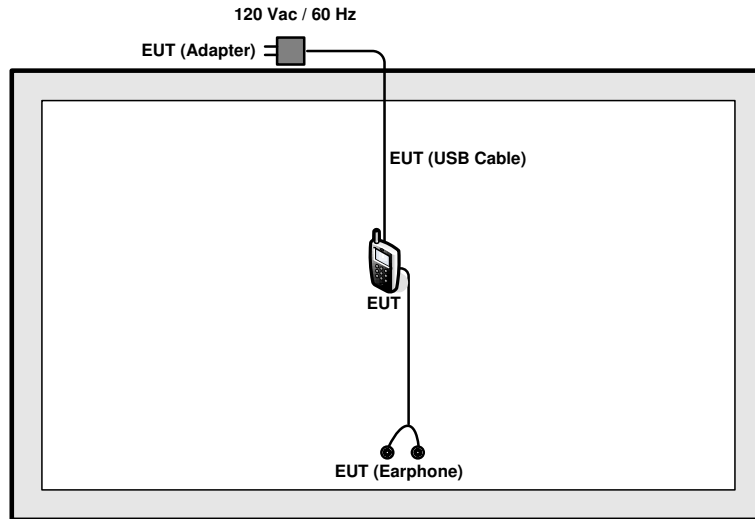

### <AC Conducted Emission Mode>

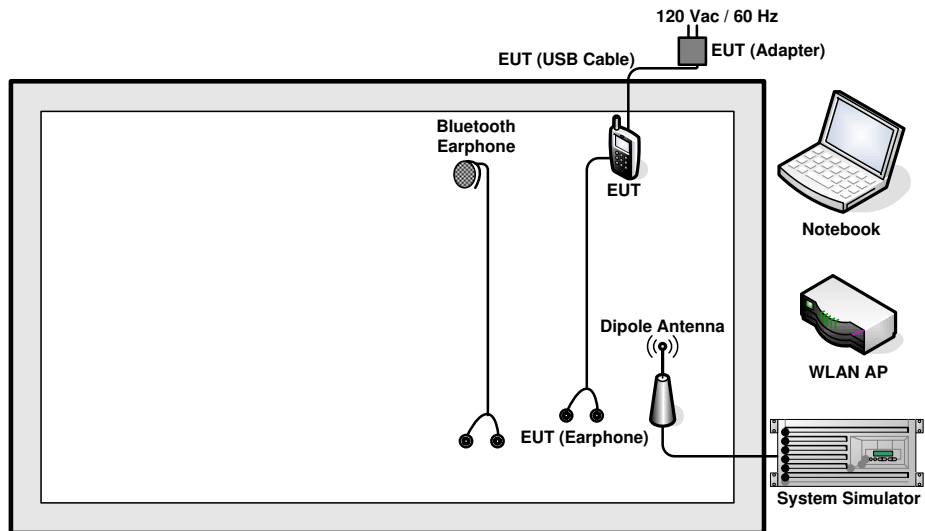

## 2.4 Support Unit used in test configuration and system

Item	Equipment	Trade Name	Model Name	FCC ID	Data Cable	Power Cord
1.	System Simulator	Anritsu	MT8820C	N/A	N/A	Unshielded, 1.8 m
2.	WLAN AP	ASUS	RT-AC66U	MSQ-RTAC66U	N/A	Unshielded, 1.8 m
3.	Notebook	Dell	Latitude E6320	FCC DoC	N/A	Shielded cable DC O/P 1.8 m Unshielded AC I/P cable 1.2 m
4.	Bluetooth Earphone	Sony Ericsson	MW600	PY700A2029	N/A	N/A

## 2.5 EUT Operation Test Setup

For WLAN function, the engineering test program was provided and enabled to make EUT continuous transmit/receive.

For AC power line conducted emissions, the EUT was set to connect with the Notebook under large package sizes transmission.

## 2.6 Measurement Results Explanation Example

**For all conducted test items:**

The offset level is set in the spectrum analyzer to compensate the RF cable loss and attenuator factor between EUT conducted output port and spectrum analyzer. With the offset compensation, the spectrum analyzer reading level is exactly the EUT RF output level.

Example :

The spectrum analyzer offset is derived from RF cable loss and attenuator factor.

*Offset = RF cable loss + attenuator factor.*

Following shows an offset computation example with cable loss 2.5 dB and 20dB attenuator.

*Offset(dB) = RF cable loss(dB) + attenuator factor(dB).*

$$= 2.5 + 20 = 22.5 \text{ (dB)}$$

### 3 Test Result

#### 3.1 6dB Bandwidth Measurement

##### 3.1.1 Limit of 6dB Bandwidth

The minimum 6 dB bandwidth shall be at least 500 kHz.

##### 3.1.2 Measuring Instruments

The measuring equipment is listed in the section 4 of this test report.

##### 3.1.3 Test Procedures

1. The testing follows FCC KDB Publication No. 558074 DTS D01 Meas. Guidance v03r05.
2. The RF output of EUT was connected to the spectrum analyzer by RF cable and attenuator. The path loss was compensated to the results for each measurement.
3. Set to the maximum power setting and enable the EUT transmit continuously.
4. Make the measurement with the spectrum analyzer's resolution bandwidth (RBW) = 100 kHz. Set the Video bandwidth (VBW) = 300 kHz. In order to make an accurate measurement. The 6 dB bandwidth must be greater than 500 kHz.
5. Measure and record the results in the test report.

##### 3.1.4 Test Setup





### 3.1.5 Test Result of 6dB Bandwidth

Please refer to Appendix A.

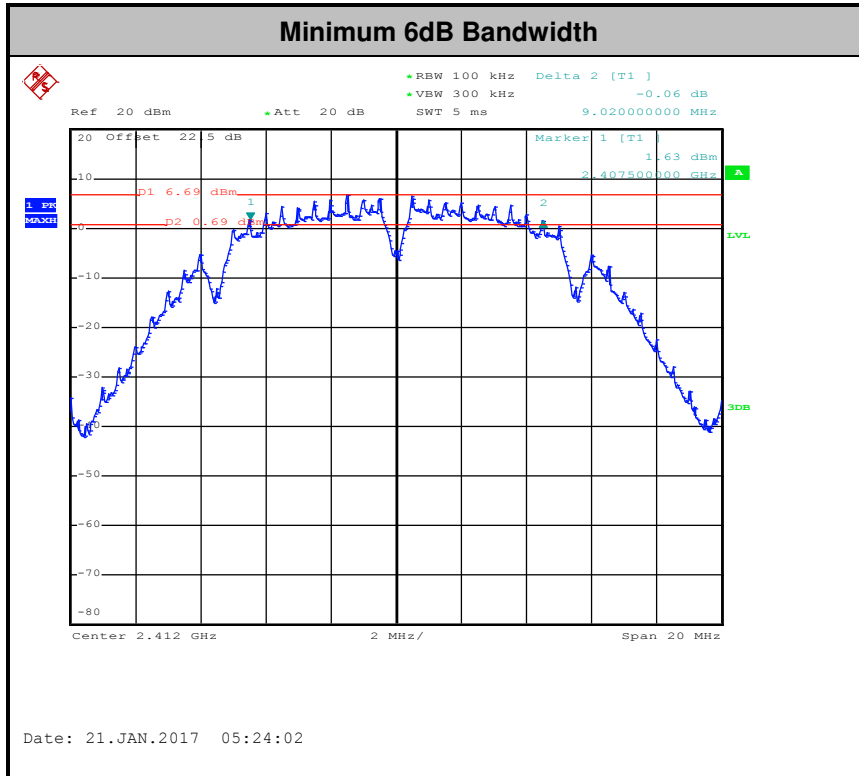

## 3.2 Output Power Measurement

### 3.2.1 Limit of Output Power

For systems using digital modulation in the 2400-2483.5MHz, the limit for peak output power is 30dBm. If transmitting antenna of directional gain greater than 6dBi are used the peak output power from the intentional radiator shall be reduced below the above stated value by the amount in dB that the directional gain of the antenna exceeds 6 dBi. In case of point-to-point operation, the limit has to be reduced by 1dB for every 3dB that the directional gain of the antenna exceeds 6dBi.

### 3.2.2 Measuring Instruments

The measuring equipment is listed in the section 4 of this test report.

### 3.2.3 Test Procedures

1. The testing follows the Measurement Procedure of FCC KDB No. 558074 DTS D01 Meas. Guidance v03r05 section 9.1.2 PKPM1 Peak power meter method.
2. The RF output of EUT was connected to the power meter by RF cable and attenuator. The path loss was compensated to the results for each measurement.
3. Set to the maximum power setting and enable the EUT transmit continuously.
4. Measure the conducted output power and record the results in the test report.

### 3.2.4 Test Setup

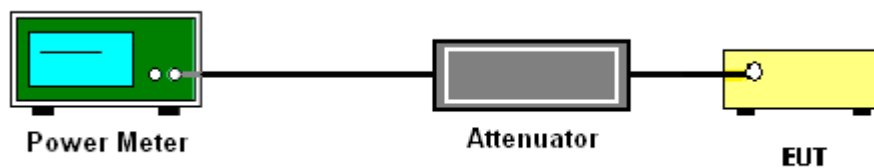

### 3.2.5 Test Result of Peak Output Power

Please refer to Appendix A.

### 3.2.6 Test Result of Average output Power (Reporting Only)

Please refer to Appendix A.

### 3.3 Power Spectral Density Measurement

#### 3.3.1 Limit of Power Spectral Density

The peak power spectral density shall not be greater than 8dBm in any 3kHz band at any time interval of continuous transmission.

#### 3.3.2 Measuring Instruments

The measuring equipment is listed in the section 4 of this test report.

#### 3.3.3 Test Procedures

1. The testing follows Measurement Procedure 10.2 Method PKPSD of FCC KDB Publication No. 558074 D01 DTS Meas. Guidance v03r05
2. The RF output of EUT was connected to the spectrum analyzer by RF cable and attenuator. The path loss was compensated to the results for each measurement.
3. Set to the maximum power setting and enable the EUT transmit continuously.
4. Make the measurement with the spectrum analyzer's resolution bandwidth (RBW) = 3 kHz. Video bandwidth VBW = 10 kHz In order to make an accurate measurement, set the span to 1.5 times DTS Channel Bandwidth. (6dB BW)
5. Detector = peak, Sweep time = auto couple, Trace mode = max hold, Allow trace to fully stabilize. Use the peak marker function to determine the maximum power level.
6. Measure and record the results in the test report.

#### 3.3.4 Test Setup





### 3.3.5 Test Result of Power Spectral Density

Please refer to Appendix A.

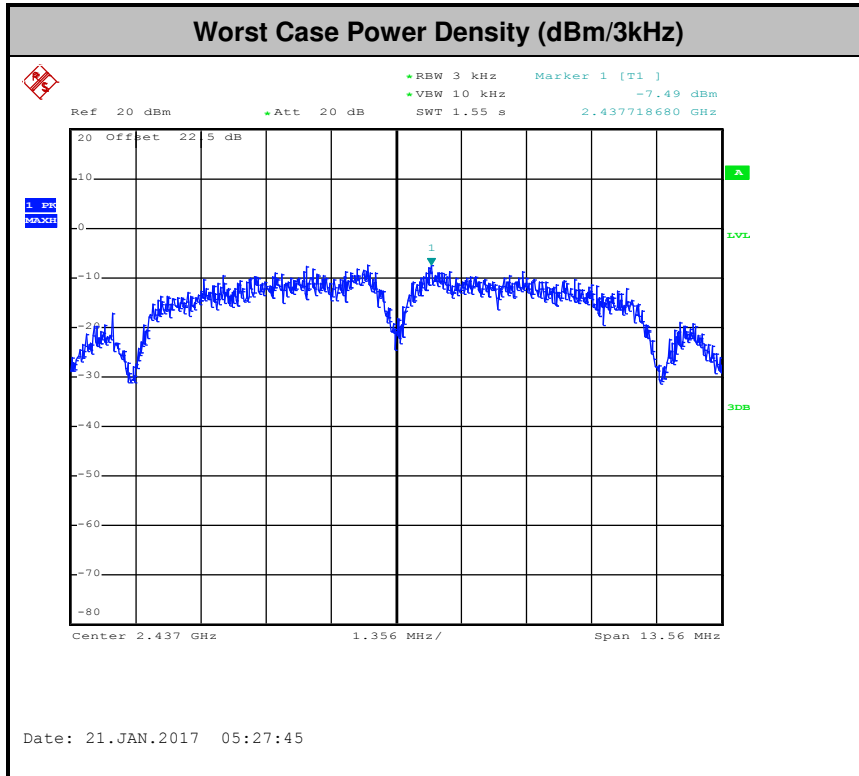

## 3.4 Conducted Band Edges and Spurious Emission Measurement

### 3.4.1 Limit of Conducted Band Edges and Spurious Emission Measurement

In any 100 kHz bandwidth outside of the authorized frequency band, the emissions which fall in the non-restricted bands shall be attenuated at least 20 dB / 30dB relative to the maximum PSD level in 100 kHz by RF conducted measurement and radiated emissions which fall in the restricted bands, as defined in Section 15.205(a), must also comply with the radiated emission limits specified in Section 15.209(a).

### 3.4.2 Measuring Instruments

The measuring equipment is listed in the section 4 of this test report.

### 3.4.3 Test Procedures

1. The testing follows FCC KDB Publication No. 558074 D01 DTS Meas. Guidance v03r05.
2. The RF output of EUT was connected to the spectrum analyzer by RF cable and attenuator. The path loss was compensated to the results for each measurement.
3. Set to the maximum power setting and enable the EUT transmit continuously.
4. Set RBW = 100 kHz, VBW=300 kHz, Peak Detector. Unwanted Emissions measured in any 100 kHz bandwidth outside of the authorized frequency band shall be attenuated by at least 20 dB relative to the maximum in-band peak PSD level in 100 kHz when maximum peak conducted output power procedure is used. If the transmitter complies with the conducted power limits based on the use of RMS averaging over a time interval, the attenuation required under this paragraph shall be 30 dB instead of 20 dB per 15.247(d).
5. Measure and record the results in the test report.
6. The RF fundamental frequency should be excluded against the limit line in the operating frequency band.

### 3.4.4 Test Setup

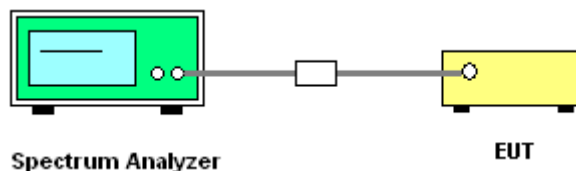





### 3.4.5 Test Result of Conducted Band Edges and Spurious Emission

Test Mode :	802.11b	Temperature :	21~25°C
Test Band :	2.4GHz Low	Relative Humidity :	51~55%
Test Channel :	01	Test Engineer :	Aking chang

#### WLAN 802.11b Channel 01

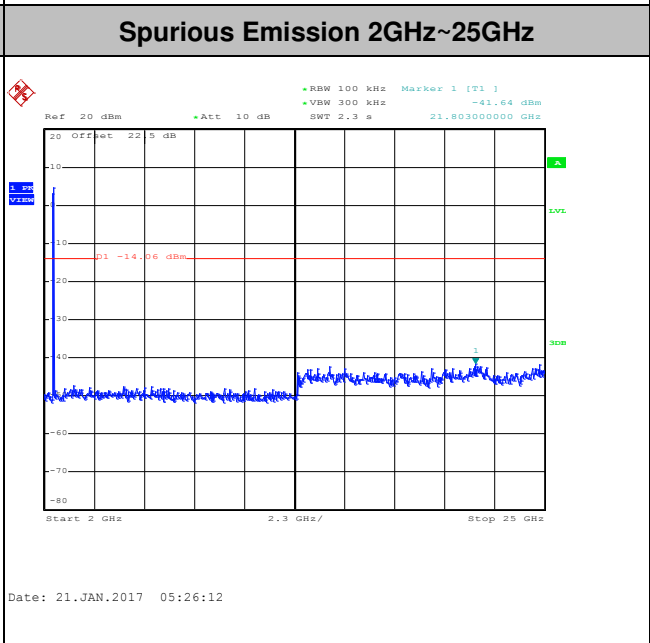
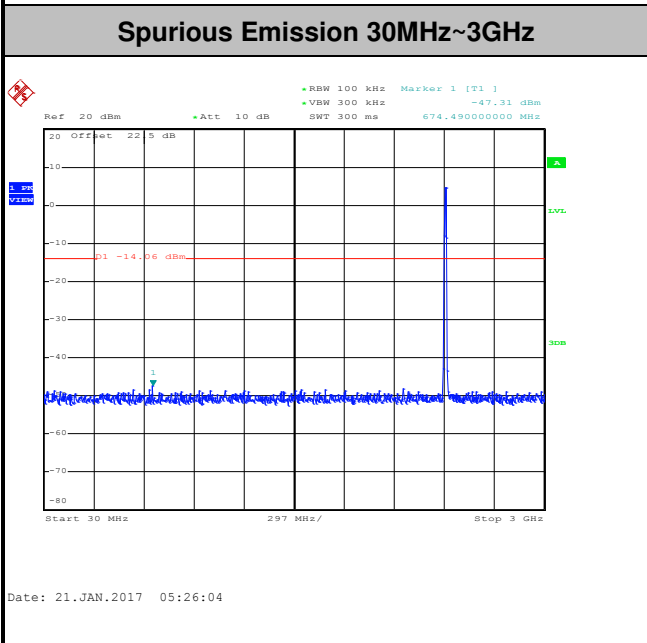
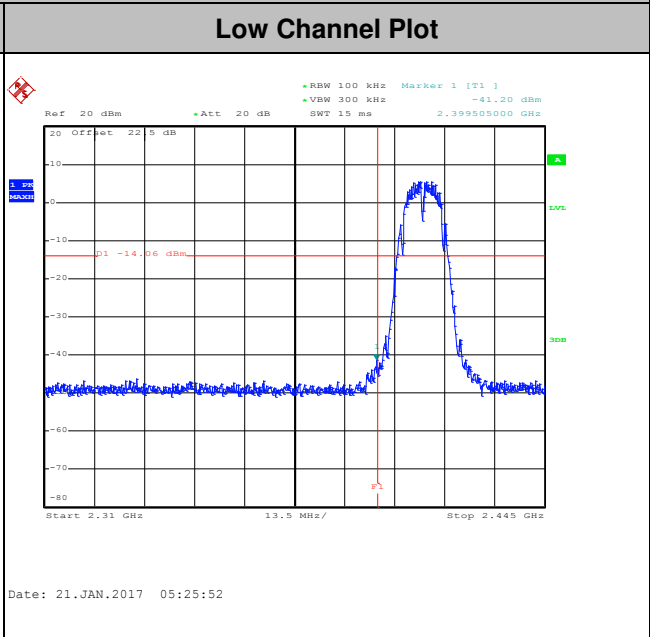
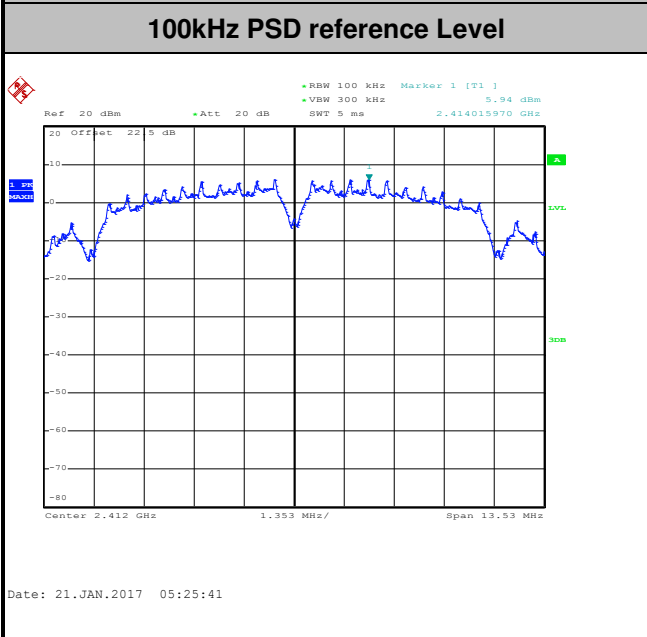



Test Mode :	802.11b	Temperature :	21~25°C
Test Band :	2.4GHz Mid	Relative Humidity :	51~55%
Test Channel :	06	Test Engineer :	Aking chang

WLAN 802.11b Channel 06

100kHz PSD reference Level

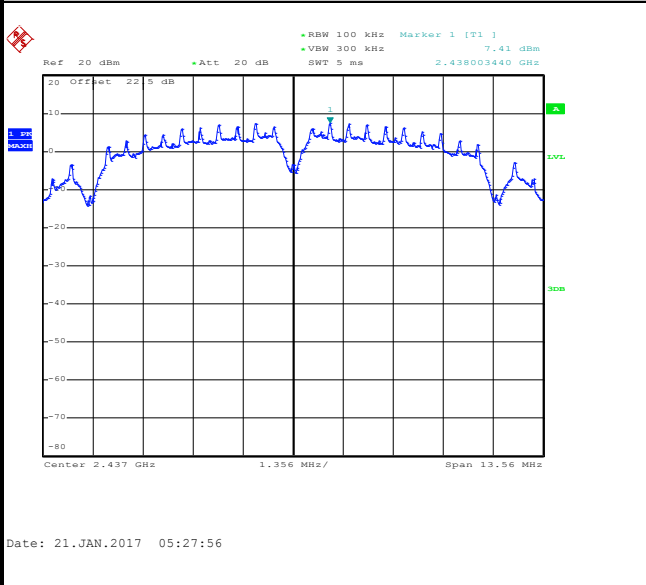

Spurious Emission 30MHz~3GHz

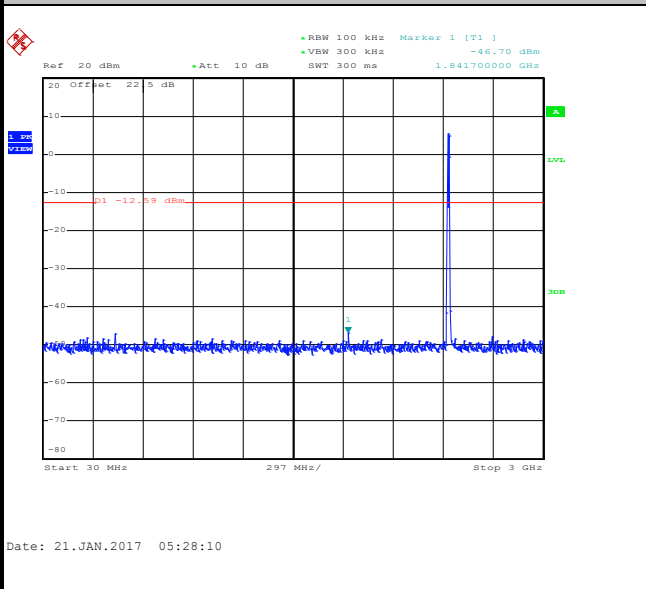

Spurious Emission 2GHz~25GHz

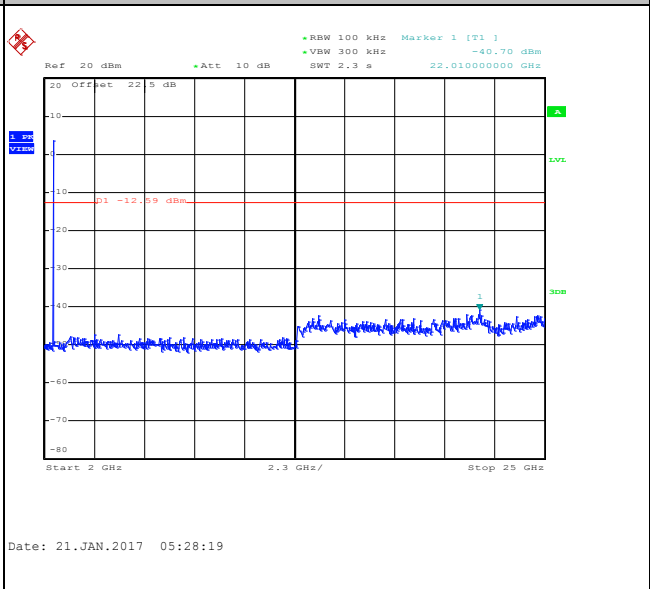



Test Mode :	802.11b	Temperature :	21~25°C
Test Band :	2.4GHz High	Relative Humidity :	51~55%
Test Channel :	11	Test Engineer :	Aking chang

WLAN 802.11b Channel 11

100kHz PSD reference Level

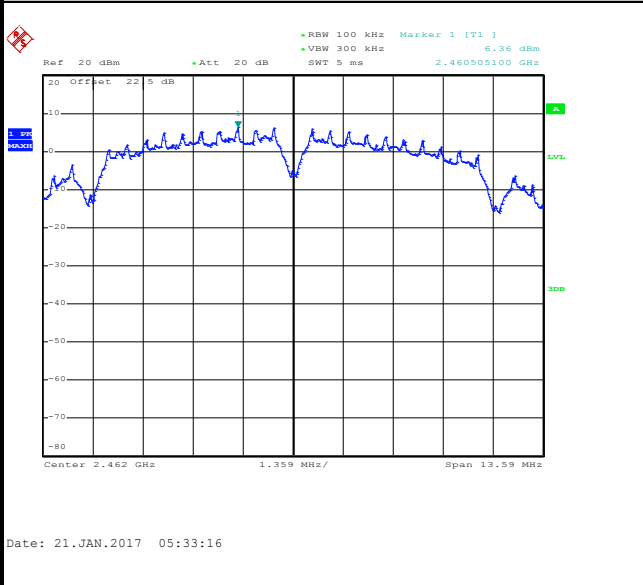

High Channel Plot

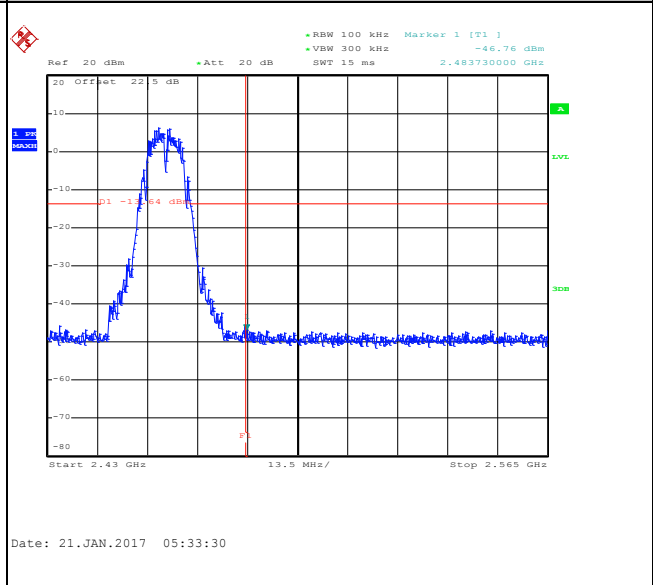

Spurious Emission 30MHz~3GHz

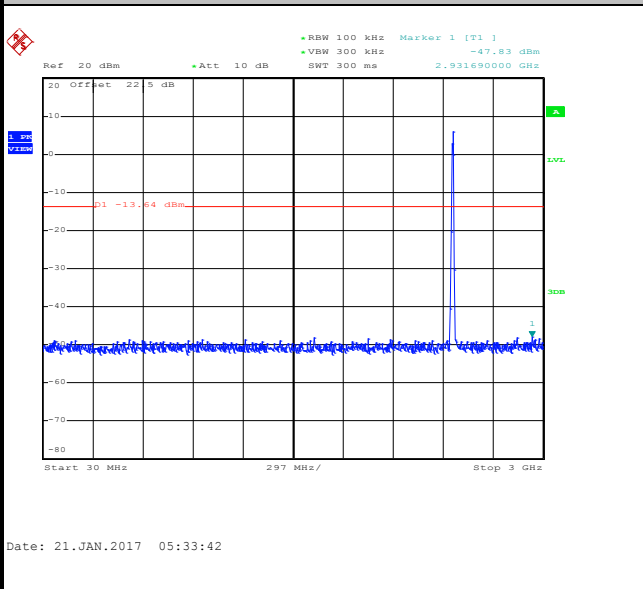

Spurious Emission 2GHz~25GHz

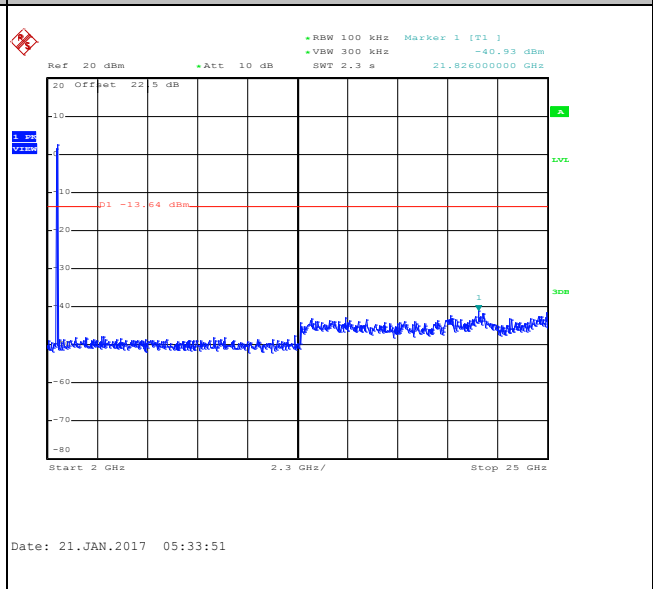



Test Mode :	802.11g	Temperature :	21~25°C
Test Band :	2.4GHz Low	Relative Humidity :	51~55%
Test Channel :	01	Test Engineer :	Aking chang

WLAN 802.11g Channel 01

100kHz PSD reference Level

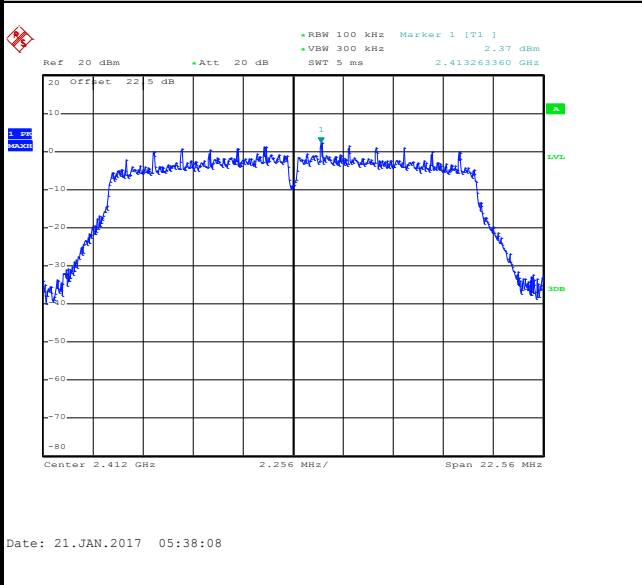

Low Channel Plot

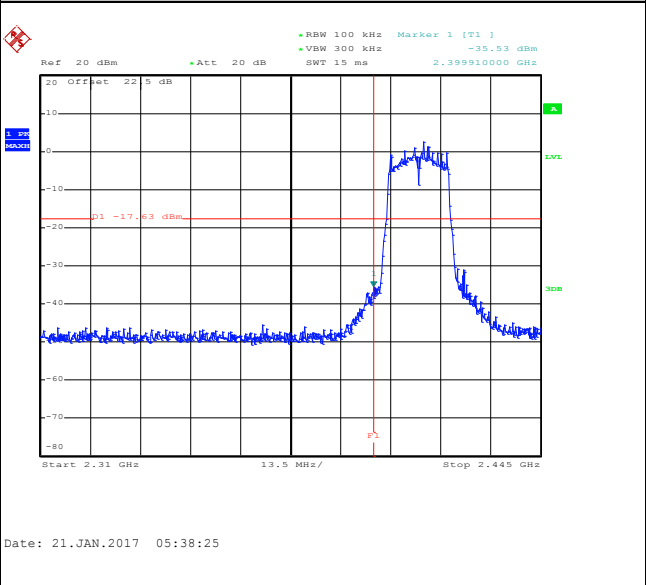

Spurious Emission 30MHz~3GHz

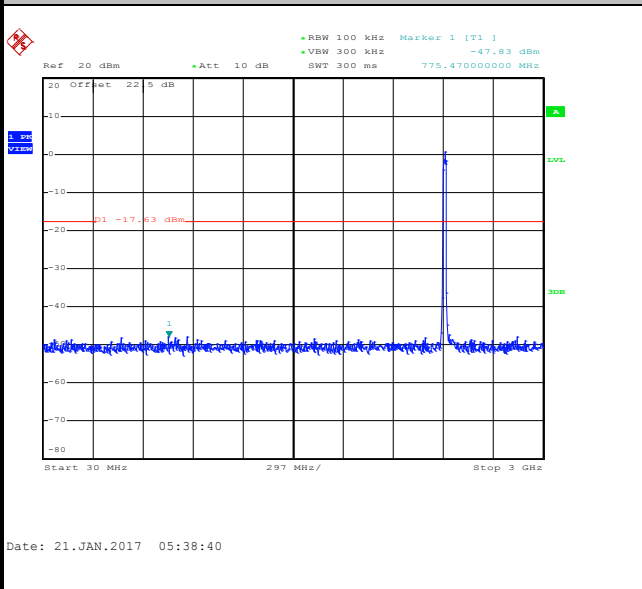

Spurious Emission 2GHz~25GHz

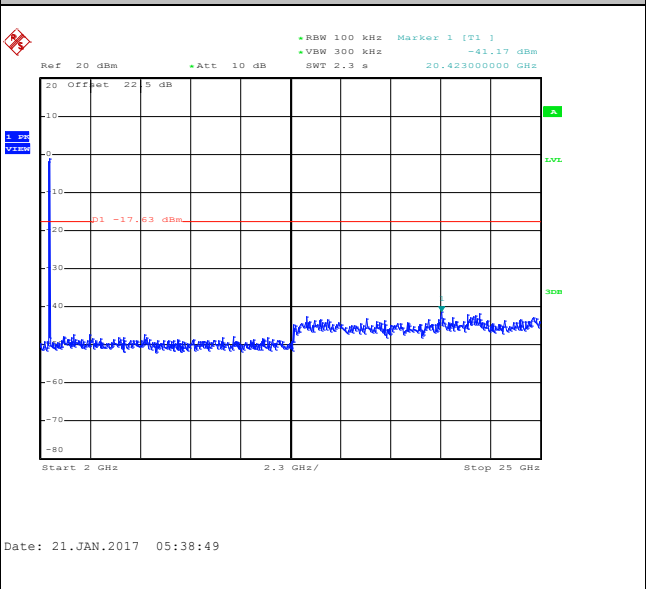



Test Mode :	802.11g	Temperature :	21~25°C
Test Band :	2.4GHz Mid	Relative Humidity :	51~55%
Test Channel :	06	Test Engineer :	Aking chang

WLAN 802.11g Channel 06

100kHz PSD reference Level

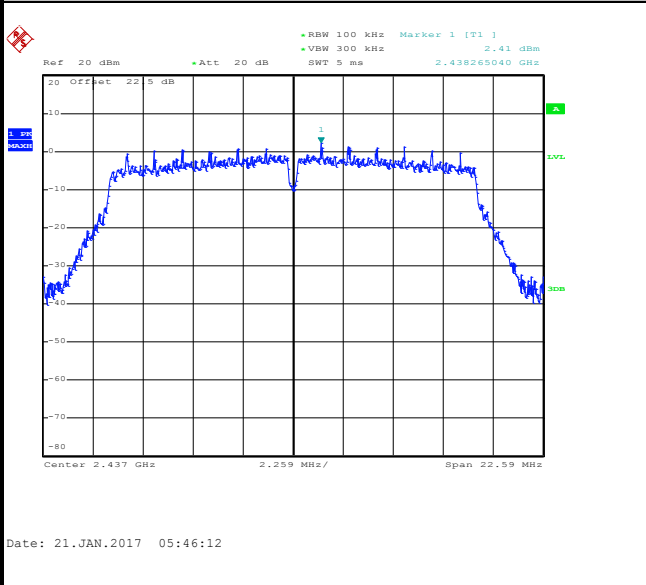

Spurious Emission 30MHz~3GHz

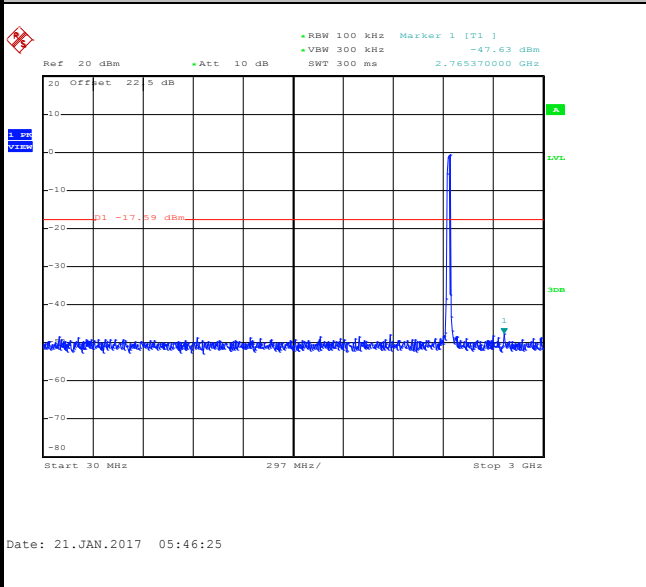

Spurious Emission 2GHz~25GHz

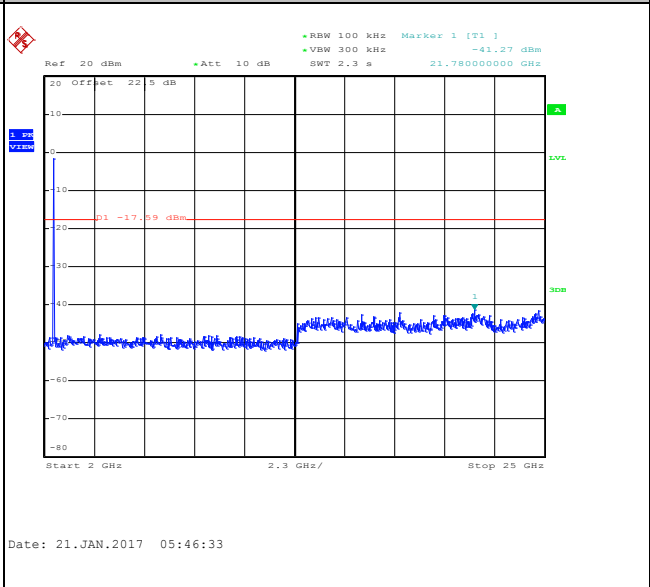



Test Mode :	802.11g	Temperature :	21~25°C
Test Band :	2.4GHz High	Relative Humidity :	51~55%
Test Channel :	11	Test Engineer :	Aking chang

WLAN 802.11g Channel 11

100kHz PSD reference Level

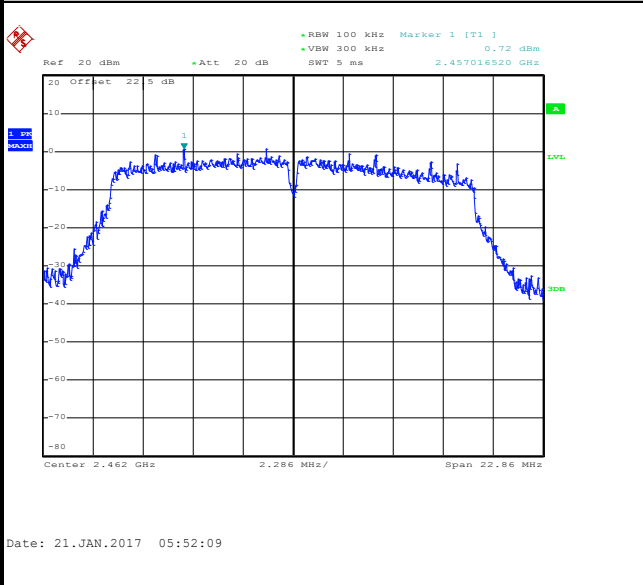

High Channel Plot

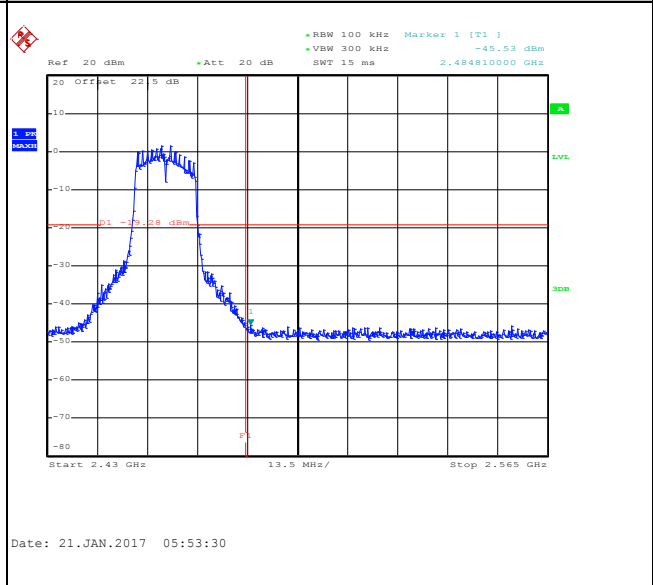

Spurious Emission 30MHz~3GHz

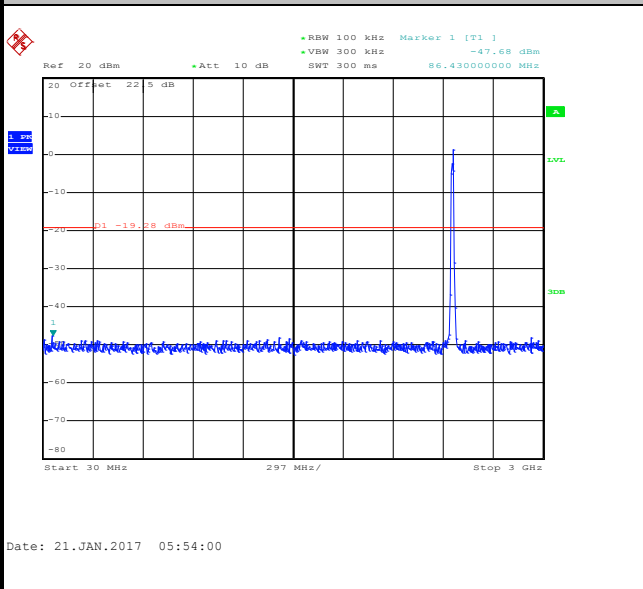

Spurious Emission 2GHz~25GHz

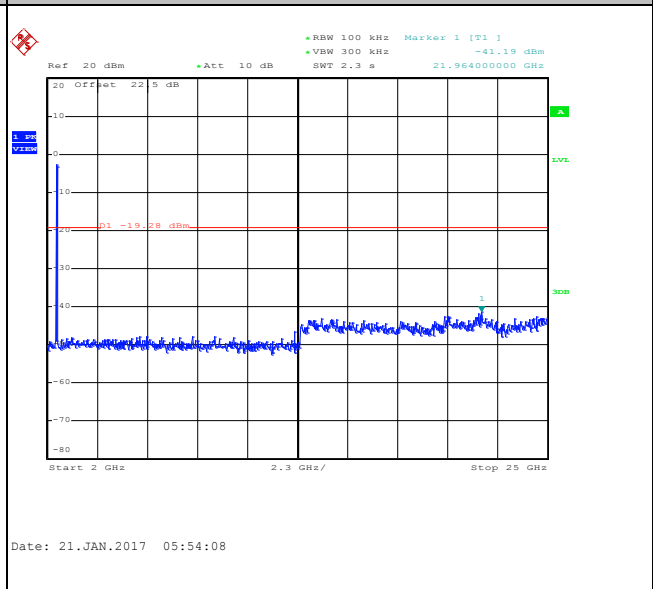



Test Mode :	802.11n HT20	Temperature :	21~25°C
Test Band :	2.4GHz Low	Relative Humidity :	51~55%
Test Channel :	01	Test Engineer :	Aking chang

WLAN 802.11n HT20 Channel 01

100kHz PSD reference Level

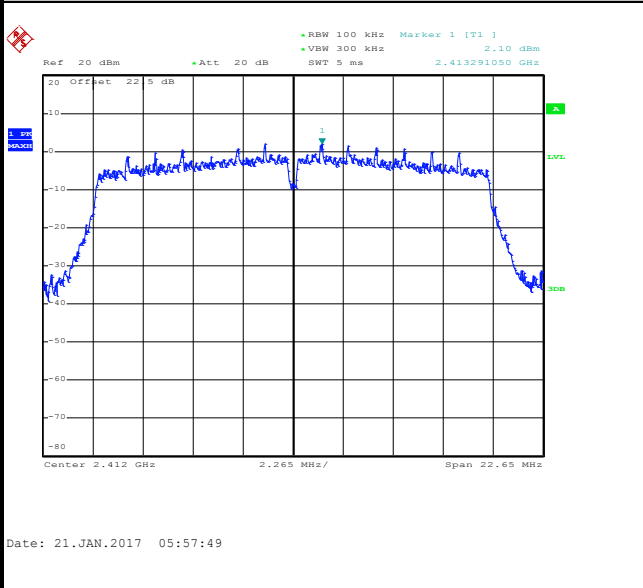

Low Channel Plot

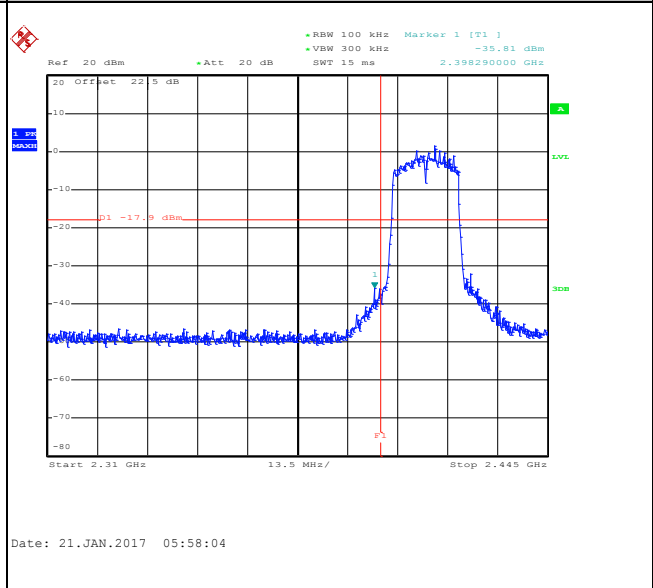

Spurious Emission 30MHz~3GHz

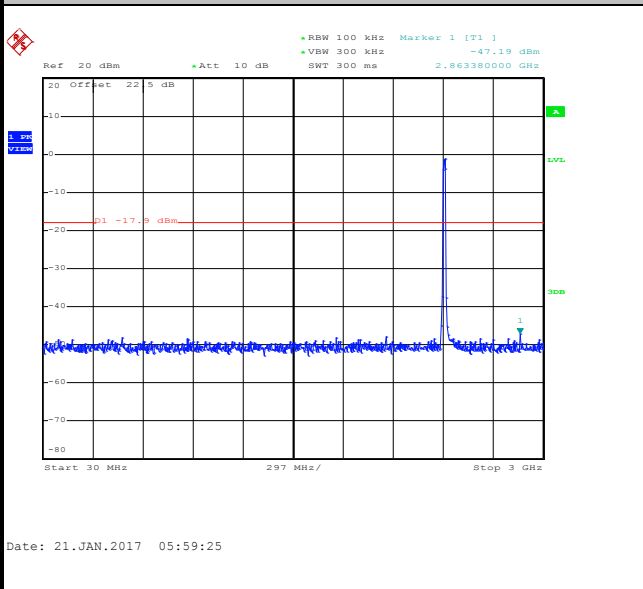

Spurious Emission 2GHz~25GHz

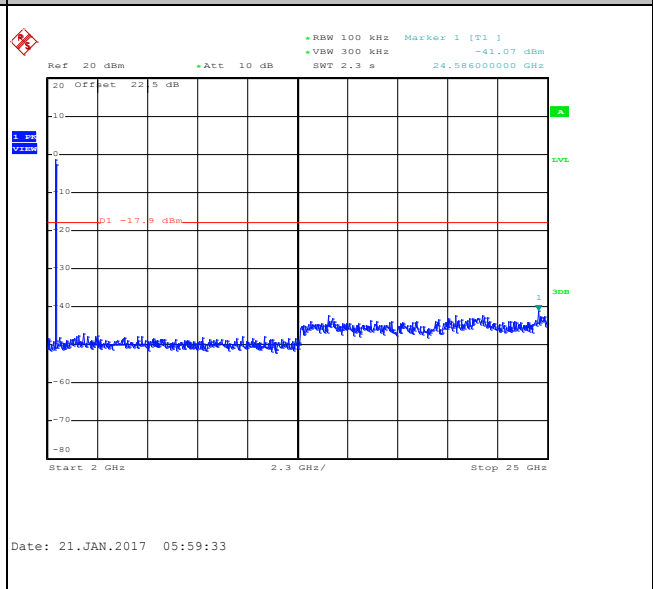



Test Mode :	802.11n HT20	Temperature :	21~25°C
Test Band :	2.4GHz Mid	Relative Humidity :	51~55%
Test Channel :	06	Test Engineer :	Aking chang

WLAN 802.11n HT20 Channel 06

100kHz PSD reference Level

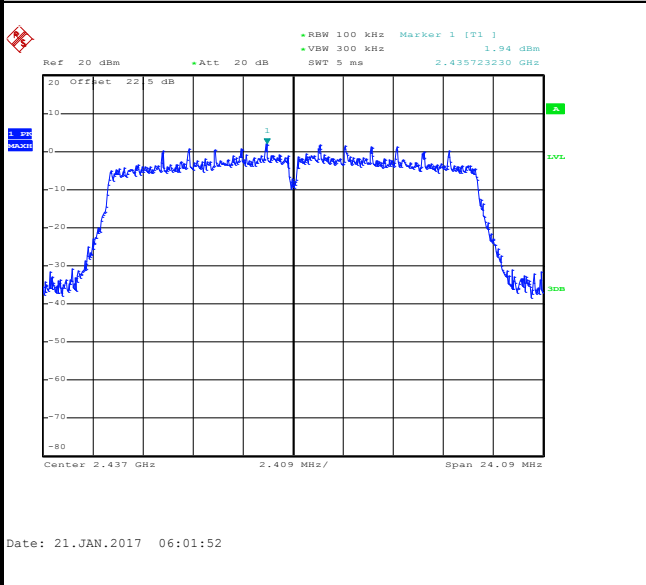

Spurious Emission 30MHz~3GHz

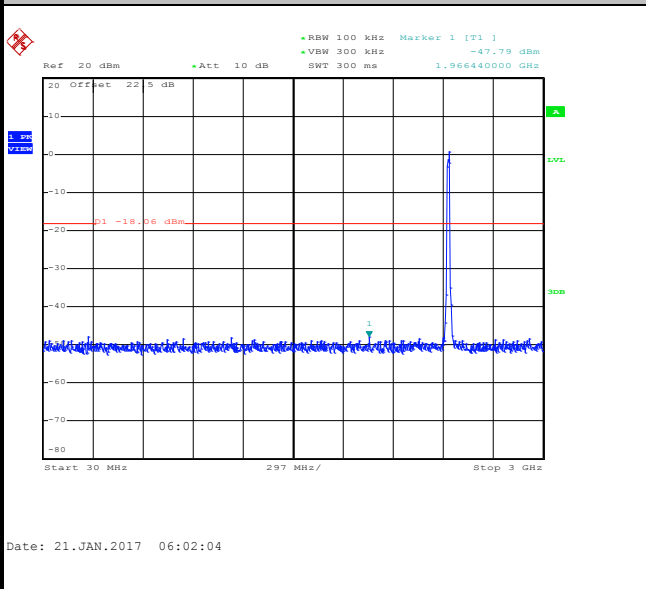

Spurious Emission 2GHz~25GHz

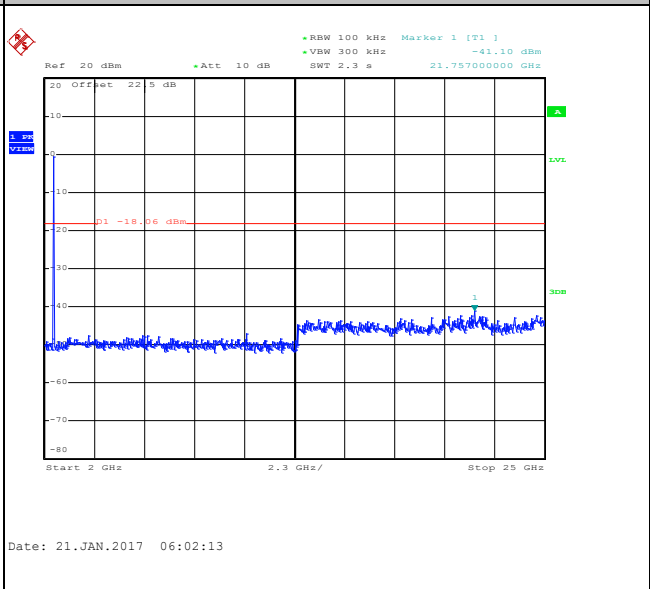





Test Mode :	802.11n HT20	Temperature :	21~25°C
Test Band :	2.4GHz High	Relative Humidity :	51~55%
Test Channel :	11	Test Engineer :	Aking chang

WLAN 802.11n HT20 Channel 11

100kHz PSD reference Level

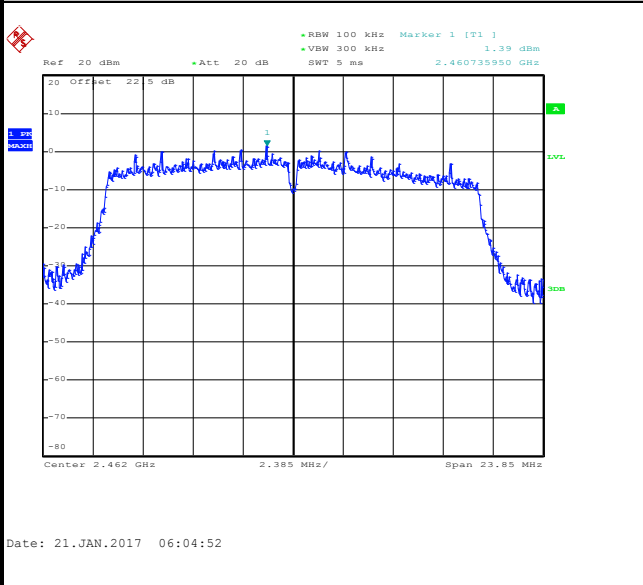

High Channel Plot

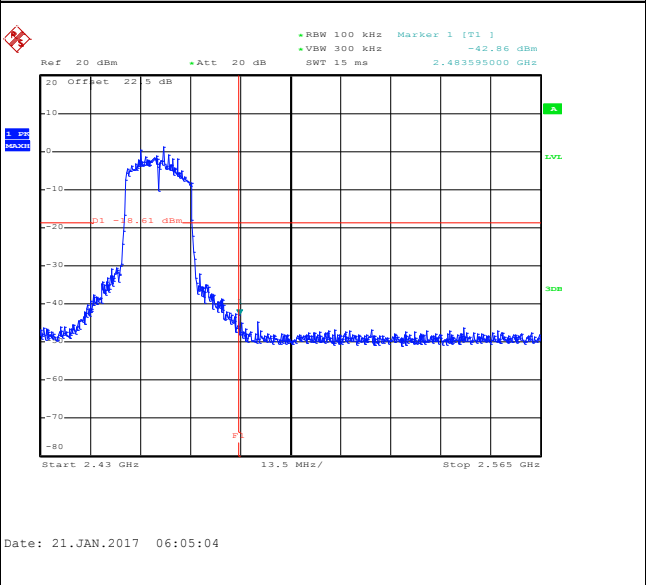

Spurious Emission 30MHz~3GHz

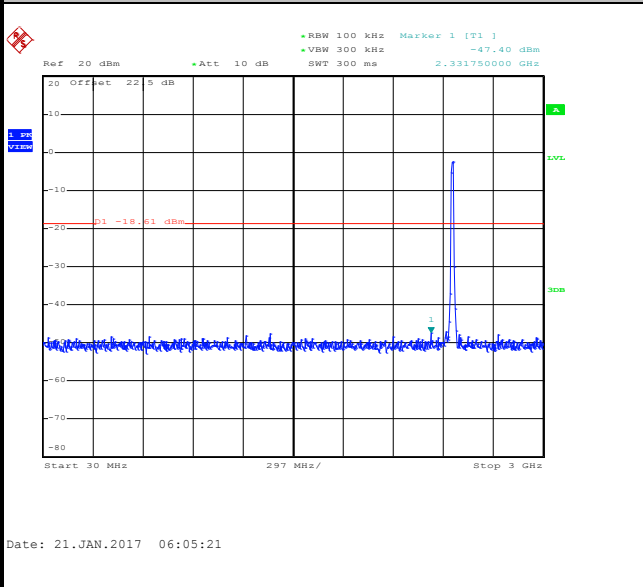

Spurious Emission 2GHz~25GHz

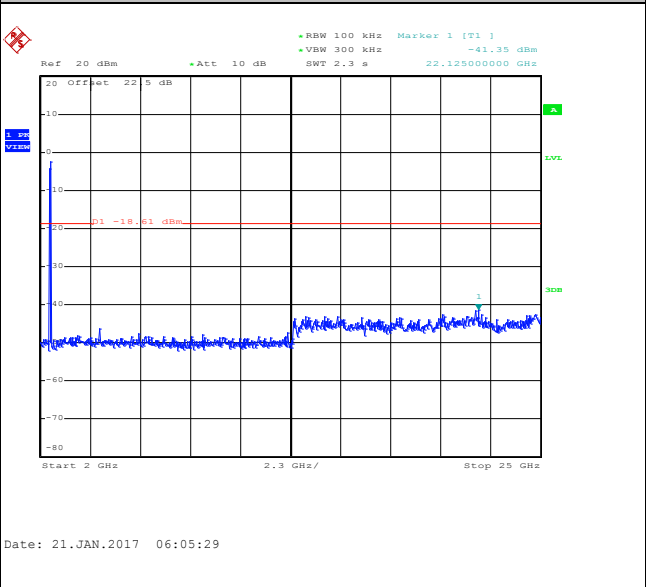



### 3.5 Radiated Band Edges and Spurious Emission Measurement

#### 3.5.1 Limit of Radiated band edge and Spurious Emission Measurement

In any 100 kHz bandwidth outside the intentional radiator frequency band, all harmonics/spurious must be at least 20 dB below the highest emission level within the authorized band. If the output power of this device was measured by spectrum analyzer, the attenuation under this paragraph shall be 30 dB instead of 20 dB. In addition, radiated emissions which fall in the restricted bands must also comply with the FCC section 15.209 limits as below.

Frequency (MHz)	Field Strength (microvolts/meter)	Measurement Distance (meters)
0.009 – 0.490	2400/F(kHz)	300
0.490 – 1.705	24000/F(kHz)	30
1.705 – 30.0	30	30
30 – 88	100	3
88 – 216	150	3
216 - 960	200	3
Above 960	500	3

#### 3.5.2 Measuring Instruments

The measuring equipment is listed in the section 4 of this test report.



### **3.5.3 Test Procedures**

1. The testing follows FCC KDB Publication No. 558074 D01 DTS Meas. Guidance v03r05.
2. The EUT was arranged to its worst case and then tune the antenna tower (from 1 m to 4 m) and turntable (from 0 degree to 360 degrees) to find the maximum reading. A pre-amp and a high pass filter are used for the test in order to get better signal level.
3. The EUT was placed on a turntable with 0.8 meter for frequency below 1GHz and 1.5 meter for frequency above 1GHz respectively above ground.
4. The EUT was set 3 meters from the interference receiving antenna, which was mounted on the top of a variable height antenna tower.
5. Corrected Reading: Antenna Factor + Cable Loss + Read Level - Preamp Factor = Level
6. For measurement below 1GHz, If the emission level of the EUT measured by the peak detector is 3 dB lower than the applicable limit, the peak emission level will be reported. Otherwise, the emission measurement will be repeated using the quasi-peak detector and reported.
7. Use the following spectrum analyzer settings:
  - (1) Span shall wide enough to fully capture the emission being measured;
  - (2) Set RBW=100 kHz for  $f < 1$  GHz; VBW  $\geq$  RBW; Sweep = auto; Detector function = peak; Trace = max hold;
  - (3) Set RBW = 1 MHz, VBW= 3MHz for  $f \geq 1$  GHz for peak measurement.  
For average measurement:
    - VBW = 10 Hz, when duty cycle is no less than 98 percent.
    - VBW  $\geq 1/T$ , when duty cycle is less than 98 percent where T is the minimum transmission duration over which the transmitter is on and is transmitting at its maximum power control level for the tested mode of operation.

### 3.5.4 Test Setup

For radiated emissions below 30MHz



For radiated emissions from 30MHz to 1GHz

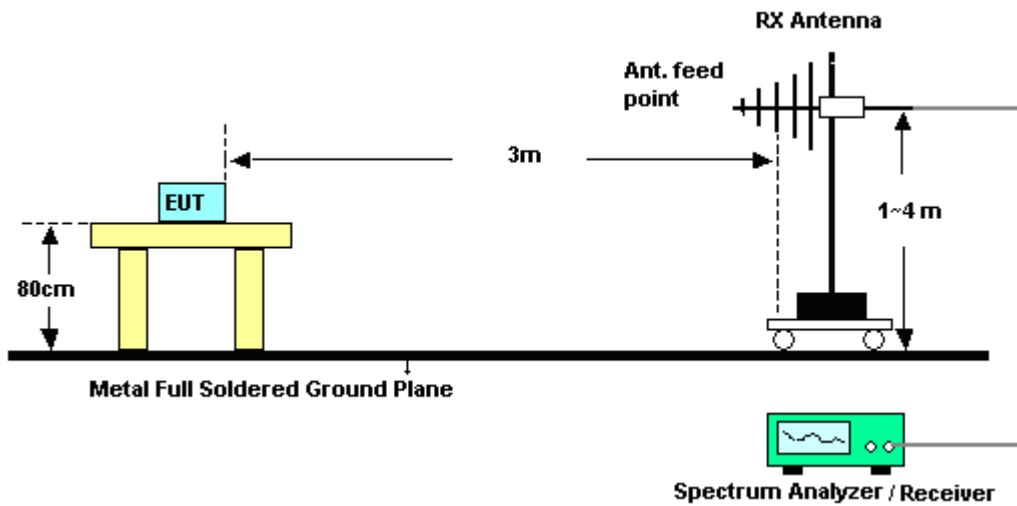

For radiated emissions above 1GHz

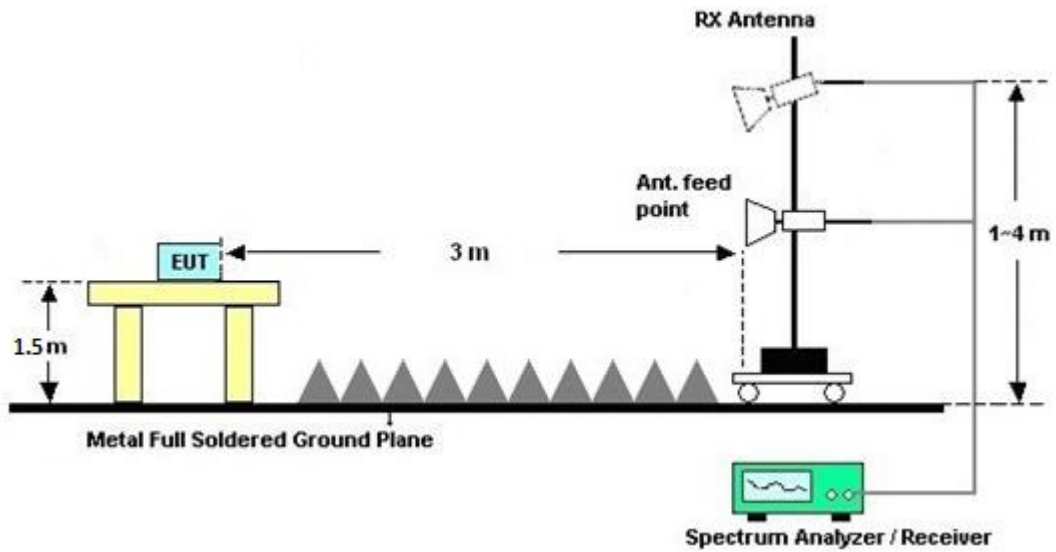

### 3.5.5 Test Results of Radiated Spurious Emissions (9kHz ~ 30MHz)

The low frequency, which started from 9 kHz to 30MHz, was pre-scanned and the result which was 20dB lower than the limit line per 15.31(o) was not reported.

### 3.5.6 Test Result of Radiated Spurious at Band Edges

Please refer to Appendix B.

### 3.5.7 Duty Cycle

Please refer to Appendix C.

### 3.5.8 Test Result of Radiated Spurious Emission (30MHz ~ 10<sup>th</sup> Harmonic)

Please refer to Appendix B.



### 3.6 AC Conducted Emission Measurement

#### 3.6.1 Limit of AC Conducted Emission

For equipment that is designed to be connected to the public utility (AC) power line, the radio frequency voltage that is conducted back onto the AC power line on any frequency or frequencies within the band 150 kHz to 30 MHz shall not exceed the limits in the following table.

Frequency of Emission (MHz)	Conducted Limit (dB $\mu$ V)	
	Quasi-Peak	Average
0.15-0.5	66 to 56*	56 to 46*
0.5-5	56	46
5-30	60	50

\*Decreases with the logarithm of the frequency.

#### 3.6.2 Measuring Instruments

The measuring equipment is listed in the section 4 of this test report.

#### 3.6.3 Test Procedures

1. The EUT was placed 0.4 meter from the conducting wall of the shielding room, and it was kept at least 80 centimeters from any other grounded conducting surface.
2. Connect EUT to the power mains through a line impedance stabilization network (LISN).
3. All the support units are connecting to the other LISN.
4. The LISN provides 50 ohm coupling impedance for the measuring instrument.
5. The FCC states that a 50 ohm, 50 microhenry LISN should be used.
6. Both sides of AC line were checked for maximum conducted interference.
7. The frequency range from 150 kHz to 30 MHz was searched.
8. Set the test-receiver system to Peak Detect Function and specified bandwidth (IF bandwidth = 9kHz) with Maximum Hold Mode.

### 3.6.4 Test Setup

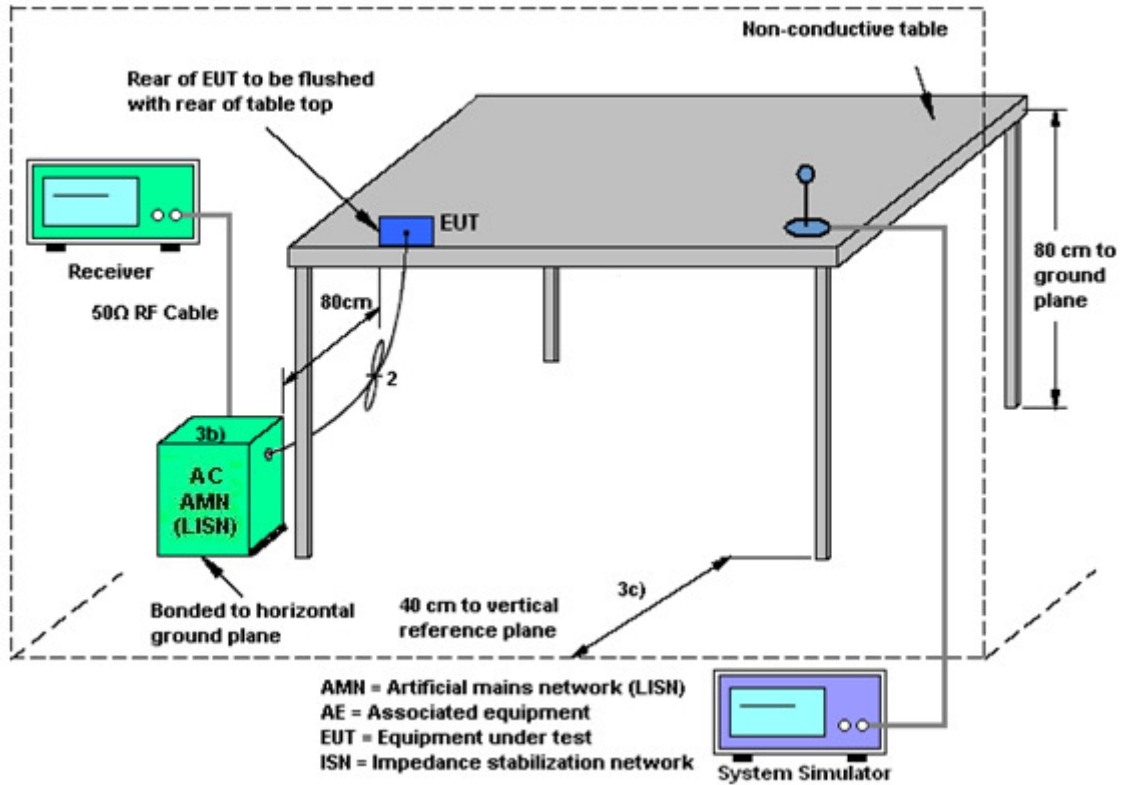



### 3.6.5 Test Result of AC Conducted Emission

Test Mode :	Mode 1	Temperature :	20~22°C
Test Engineer :	Kai-Chun Chu & Arthur Hsieh	Relative Humidity :	40~42%
Test Voltage :	120Vac / 60Hz	Phase :	Line
Function Type :	GSM850 Idle + Bluetooth Idle + WLAN Idle + USB Cable (Charging from Adapter) + Earphone + NFC On + SIM2		

ENV216 Auto Test NCC CE Power Bar - L

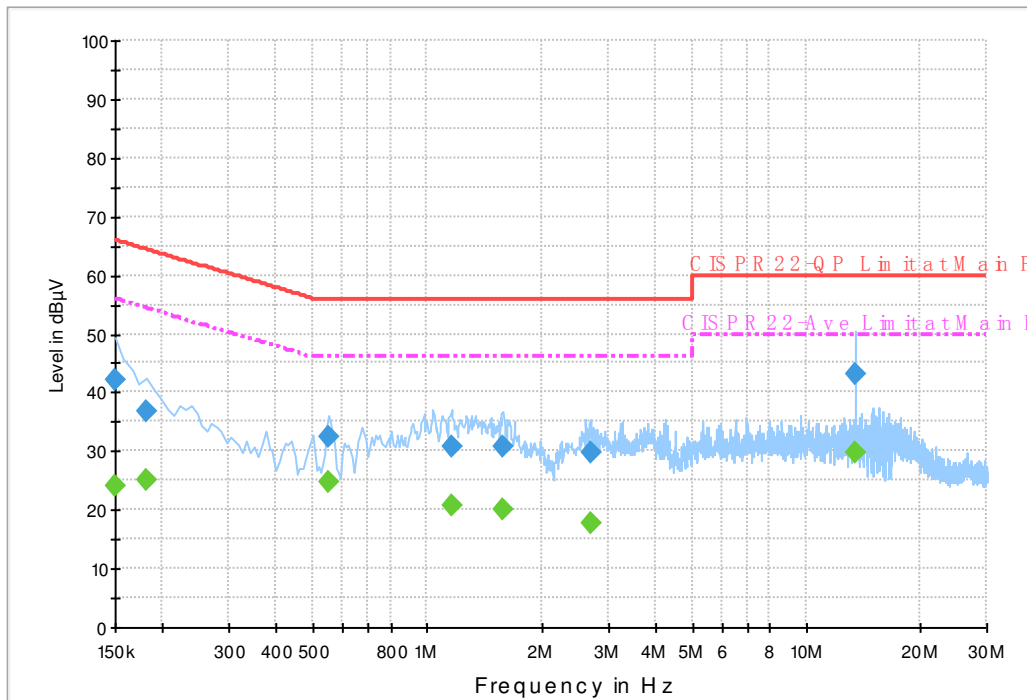

#### Final Result : Quasi-Peak

Frequency (MHz)	Quasi-Peak (dBµV)	Filter	Line	Corr. (dB)	Margin (dB)	Limit (dBµV)
0.150000	42.3	Off	L1	19.6	23.7	66.0
0.182000	36.7	Off	L1	19.6	27.7	64.4
0.550000	32.5	Off	L1	19.6	23.5	56.0
1.158000	30.9	Off	L1	19.6	25.1	56.0
1.582000	30.6	Off	L1	19.6	25.4	56.0
2.694000	29.9	Off	L1	19.3	26.1	56.0
13.558000	43.3	Off	L1	20.1	16.7	60.0

#### Final Result : Average

Frequency (MHz)	Average (dBµV)	Filter	Line	Corr. (dB)	Margin (dB)	Limit (dBµV)
0.150000	24.1	Off	L1	19.6	31.9	56.0
0.182000	25.0	Off	L1	19.6	29.4	54.4
0.550000	24.6	Off	L1	19.6	21.4	46.0
1.158000	20.9	Off	L1	19.6	25.1	46.0
1.582000	20.1	Off	L1	19.6	25.9	46.0
2.694000	17.6	Off	L1	19.3	28.4	46.0
13.558000	29.7	Off	L1	20.1	20.3	50.0





Test Mode :	Mode 1	Temperature :	20~22°C
Test Engineer :	Kai-Chun Chu & Arthur Hsieh	Relative Humidity :	40~42%
Test Voltage :	120Vac / 60Hz	Phase :	Neutral
Function Type :	GSM850 Idle + Bluetooth Idle + WLAN Idle + USB Cable (Charging from Adapter) + Earphone + NFC On + SIM2		

ENV216 Auto Test NCC CE Power Bar - N

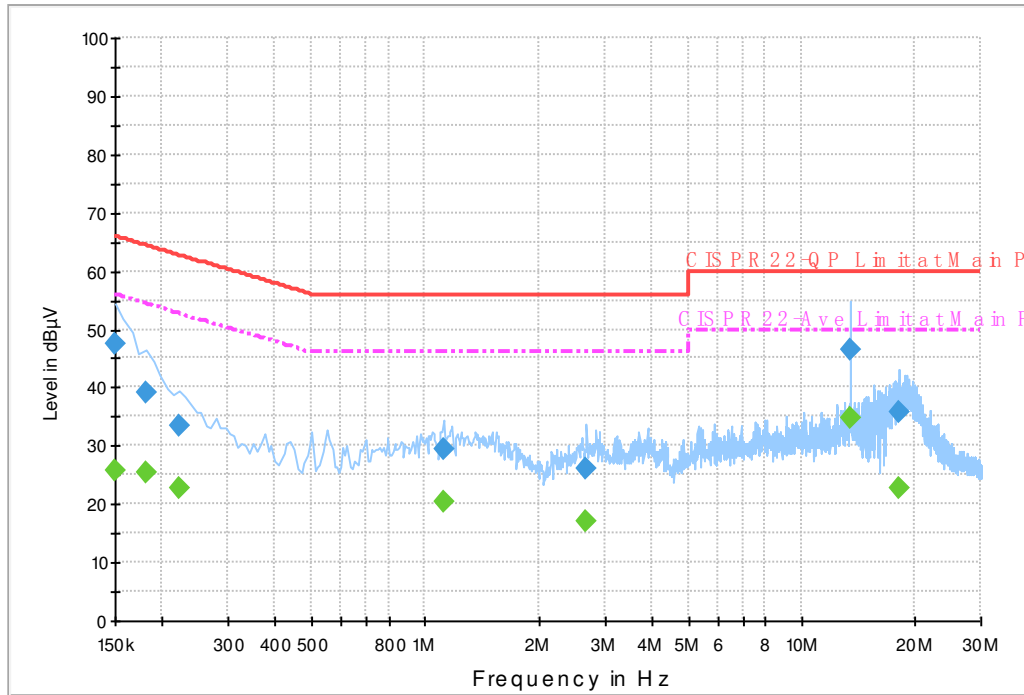

**Final Result : Quasi-Peak**

Frequency (MHz)	Quasi-Peak (dBµV)	Filter	Line	Corr. (dB)	Margin (dB)	Limit (dBµV)
0.150000	47.6	Off	N	19.6	18.4	66.0
0.182000	39.0	Off	N	19.5	25.4	64.4
0.222000	33.5	Off	N	19.5	29.2	62.7
1.118000	29.3	Off	N	19.6	26.7	56.0
2.686000	26.0	Off	N	19.4	30.0	56.0
13.558000	46.6	Off	N	20.2	13.4	60.0
18.158000	35.8	Off	N	20.4	24.2	60.0

**Final Result : Average**

Frequency (MHz)	Average (dBµV)	Filter	Line	Corr. (dB)	Margin (dB)	Limit (dBµV)
0.150000	25.7	Off	N	19.6	30.3	56.0
0.182000	25.6	Off	N	19.5	28.8	54.4
0.222000	22.7	Off	N	19.5	30.0	52.7
1.118000	20.4	Off	N	19.6	25.6	46.0
2.686000	16.9	Off	N	19.4	29.1	46.0
13.558000	34.8	Off	N	20.2	15.2	50.0
18.158000	22.6	Off	N	20.4	27.4	50.0



## **3.7 Antenna Requirements**

### **3.7.1 Standard Applicable**

If directional gain of transmitting antennas is greater than 6dBi, the power shall be reduced by the same level in dB comparing to gain minus 6dBi. The use of a permanently attached antenna or of an antenna that uses a unique coupling to the intentional radiator shall be considered sufficient to comply with the FCC rule.

### **3.7.2 Antenna Anti-Replacement Construction**

An embedded-in antenna design is used.

### **3.7.3 Antenna Gain**

The antenna peak gain of EUT is less than 6 dBi. Therefore, it is not necessary to reduce maximum peak output power limit.



## 4 List of Measuring Equipment

Instrument	Manufacturer	Model No.	Serial No.	Characteristics	Calibration Date	Test Date	Due Date	Remark
Hygrometer	Testo	608-H2	41410069	N/A	Aug. 28, 2016	Jan. 21, 2017	Aug. 27, 2017	Conducted (TH05-HY)
Power Meter	Anritsu	ML2495A	0932001	300MHz~40GHz	Sep. 29, 2016	Jan. 21, 2017	Sep. 28, 2017	Conducted (TH05-HY)
Power Sensor	Anritsu	MA2411B	0846202	300MHz~40GHz	Sep. 29, 2016	Jan. 21, 2017	Sep. 28, 2017	Conducted (TH05-HY)
Spectrum Analyzer	Rohde & Schwarz	FSP40	100055	9kHz-40GHz	Jul. 17, 2016	Jan. 21, 2017	Jul. 16, 2017	Conducted (TH05-HY)
Bilog Antenna	TESEQ	CBL 6111D&00800 N1D01N-06	35419&03	30MHz to 1GHz	Jan. 07, 2017	Jan. 22, 2017 ~ Jan. 24, 2017	Jan. 06, 2018	Radiation (03CH07-HY)
Double Ridge Horn Antenna	ESCO	3117	00075962	1GHz ~ 18GHz	Aug. 19, 2016	Jan. 22, 2017 ~ Jan. 24, 2017	Aug. 18, 2017	Radiation (03CH07-HY)
EMI Test Receiver	Keysight	N9038A (MXE)	MY541300 85	20Hz ~ 8.4GHz	Oct. 26, 2016	Jan. 22, 2017 ~ Jan. 24, 2017	Oct. 25, 2017	Radiation (03CH07-HY)
Loop Antenna	Rohde & Schwarz	HFH2-Z2	100315	9 kHz~30 MHz	Sep. 02, 2016	Jan. 22, 2017 ~ Jan. 24, 2017	Sep. 01, 2017	Radiation (03CH07-HY)
Preamplifier	MITEQ	AMF-7D-0010 1800-30-10P	1590075	1GHz ~ 18GHz	Apr. 15, 2016	Jan. 22, 2017 ~ Jan. 24, 2017	Apr. 14, 2017	Radiation (03CH07-HY)
Preamplifier	COM-POWER	PA-103A	161241	10MHz-1GHz	Mar. 18, 2016	Jan. 22, 2017 ~ Jan. 24, 2017	Mar. 17, 2017	Radiation (03CH07-HY)
Preamplifier	Agilent	8449B	3008A023 62	1GHz~ 26.5GHz	Oct. 12, 2016	Jan. 22, 2017 ~ Jan. 24, 2017	Oct. 11, 2017	Radiation (03CH07-HY)
Spectrum Analyzer	Agilent	N9010A	MY534701 18	10Hz~44GHz	Feb. 27, 2016	Jan. 22, 2017 ~ Jan. 24, 2017	Feb. 26, 2017	Radiation (03CH07-HY)
Controller	Max-Full	MF7802	MF780208 368	Control Ant Mast	NCR	Jan. 22, 2017 ~ Jan. 24, 2017	NCR	Radiation (03CH07-HY)
Antenna Mast	Max-Full	MFA520BS	N/A	1m~4m	NCR	Jan. 22, 2017 ~ Jan. 24, 2017	NCR	Radiation (03CH07-HY)
Turn Table	ChainTek	Chaintek 3000	N/A	0~360 Degree	NCR	Jan. 22, 2017 ~ Jan. 24, 2017	NCR	Radiation (03CH07-HY)
Loop Cable	Rohde & Schwarz	N/A	N/A	9KHz~30MHz	Dec. 01, 2016	Jan. 22, 2017 ~ Jan. 24, 2017	Nov. 30, 2017	Radiation (03CH07-HY)
Preamplifier	MITEQ	JS44-180040 00-33-8P	1840917	18GHz ~ 40GHz	Jun. 14, 2016	Jan. 22, 2017 ~ Jan. 24, 2017	Jun. 13, 2017	Radiation (03CH07-HY)
SHF-EHF Horn Antenna	SCHWARZBECK	BBHA 9170	BBHA9170 584	18GHz- 40GHz	Nov. 08, 2016	Jan. 22, 2017 ~ Jan. 24, 2017	Nov. 07, 2017	Radiation (03CH07-HY)



AC Power Source	ChainTek	APC-1000W	N/A	N/A	NCR	Jan. 26, 2017 ~ Feb. 18, 2017	NCR	Conduction (CO05-HY)
EMI Test Receiver	Rohde & Schwarz	ESCI 7	100724	9kHz~7GHz	Aug. 30, 2016	Jan. 26, 2017 ~ Feb. 18, 2017	Aug. 29, 2017	Conduction (CO05-HY)
Hygrometer	Testo	608-H1	34913912	N/A	Apr. 19, 2016	Jan. 26, 2017 ~ Feb. 18, 2017	Apr. 18, 2017	Conduction (CO05-HY)
LISN	Rohde & Schwarz	ENV216	100080	9kHz~30MHz	Nov. 29, 2016	Jan. 26, 2017 ~ Feb. 18, 2017	Nov. 28, 2017	Conduction (CO05-HY)
LF Cable	HUBER + SUHNER	RG-214/U	LF01	N/A	Jan. 05, 2017	Jan. 26, 2017 ~ Feb. 18, 2017	Jan. 04, 2018	Conduction (CO05-HY)
Pulse Limiter	Rohde & Schwarz	ESH3-Z2	100851	N/A	Jan. 05, 2017	Jan. 26, 2017 ~ Feb. 18, 2017	Jan. 04, 2018	Conduction (CO05-HY)

NCR: No Calibration Required



## 5 Uncertainty of Evaluation

### Uncertainty of Conducted Emission Measurement (150kHz ~ 30MHz)

Measuring Uncertainty for a Level of Confidence of 95% ( $U = 2Uc(y)$ )	2.7 dB
---	--------

### Uncertainty of Radiated Emission Measurement (30 MHz ~ 1000 MHz)

Measuring Uncertainty for a Level of Confidence of 95% ( $U = 2Uc(y)$ )	5.7 dB
---	--------

### Uncertainty of Radiated Emission Measurement (1000 MHz ~ 18000 MHz)

Measuring Uncertainty for a Level of Confidence of 95% ( $U = 2Uc(y)$ )	5.5 dB
---	--------

### Uncertainty of Radiated Emission Measurement (18000 MHz ~ 40000 MHz)

Measuring Uncertainty for a Level of Confidence of 95% ( $U = 2Uc(y)$ )	5.2 dB
---	--------



## **Appendix A. Conducted Test Results**

Test Engineer:	Aking chang	Temperature:	21~25	°C
Test Date:	2017/01/21	Relative Humidity:	51~55	%

**TEST RESULTS DATA**  
**6dB Bandwidth**

2.4GHz Band							
Mod.	Data Rate	N <sub>TX</sub>	CH.	Freq. (MHz)	6dB BW (MHz)	6dB BW Limit (MHz)	Pass/Fail
11b	1Mbps	1	1	2412	9.02	0.50	Pass
11b	1Mbps	1	6	2437	9.04	0.50	Pass
11b	1Mbps	1	11	2462	9.06	0.50	Pass
11g	6Mbps	1	1	2412	15.04	0.50	Pass
11g	6Mbps	1	6	2437	15.06	0.50	Pass
11g	6Mbps	1	11	2462	15.24	0.50	Pass
HT20	MCS0	1	1	2412	15.10	0.50	Pass
HT20	MCS0	1	6	2437	16.06	0.50	Pass
HT20	MCS0	1	11	2462	15.90	0.50	Pass



**TEST RESULTS DATA**  
**Peak Power Table**

2.4GHz Band										
Mod.	Data Rate	NTX	CH.	Freq. (MHz)	Peak Conducted Power (dBm)	Conducted Power Limit (dBm)	DG (dBi)	EIRP Power (dBm)	EIRP Power Limit (dBm)	Pass /Fail
11b	1Mbps	1	1	2412	18.64	30.00	0.75	19.39	36.00	Pass
11b	1Mbps	1	6	2437	18.93	30.00	0.75	19.68	36.00	Pass
11b	1Mbps	1	11	2462	18.27	30.00	0.75	19.02	36.00	Pass
11g	6Mbps	1	1	2412	21.96	30.00	0.75	22.71	36.00	Pass
11g	6Mbps	1	6	2437	21.99	30.00	0.75	22.74	36.00	Pass
11g	6Mbps	1	11	2462	20.85	30.00	0.75	21.60	36.00	Pass
HT20	MCS0	1	1	2412	21.99	30.00	0.75	22.74	36.00	Pass
HT20	MCS0	1	6	2437	22.04	30.00	0.75	22.79	36.00	Pass
HT20	MCS0	1	11	2462	20.85	30.00	0.75	21.60	36.00	Pass

**TEST RESULTS DATA**  
**Average Power Table**  
**(Reporting Only)**

2.4GHz Band						
Mod.	Data Rate	NTX	CH.	Freq. (MHz)	Duty Factor (dB)	Average Conducted Power (dBm)
11b	1Mbps	1	1	2412	0.00	15.55
11b	1Mbps	1	6	2437	0.00	15.94
11b	1Mbps	1	11	2462	0.00	15.43
11g	6Mbps	1	1	2412	0.12	12.81
11g	6Mbps	1	6	2437	0.12	12.84
11g	6Mbps	1	11	2462	0.12	12.44
HT20	MCS0	1	1	2412	0.13	12.56
HT20	MCS0	1	6	2437	0.13	12.82
HT20	MCS0	1	11	2462	0.13	12.45

**TEST RESULTS DATA**  
**Peak Power Density**

2.4GHz Band								
Mod.	Data Rate	NTX	CH.	Freq. (MHz)	Peak PSD (dBm /3kHz)	DG (dBi)	Peak PSD Limit (dBm /3kHz)	Pass/Fail
11b	1Mbps	1	1	2412	-7.72	0.75	8.00	Pass
11b	1Mbps	1	6	2437	-7.49	0.75	8.00	Pass
11b	1Mbps	1	11	2462	-8.33	0.75	8.00	Pass
11g	6Mbps	1	1	2412	-12.31	0.75	8.00	Pass
11g	6Mbps	1	6	2437	-13.12	0.75	8.00	Pass
11g	6Mbps	1	11	2462	-11.46	0.75	8.00	Pass
HT20	MCS0	1	1	2412	-11.76	0.75	8.00	Pass
HT20	MCS0	1	6	2437	-11.40	0.75	8.00	Pass
HT20	MCS0	1	11	2462	-12.10	0.75	8.00	Pass



# Appendix B. Radiated Spurious Emission

2.4GHz 2400~2483.5MHz

WIFI 802.11b (Band Edge @ 3m)

WIFI Ant. 1	Note	Frequency ( MHz )	Level ( dBμV/m )	Over Limit ( dB )	Limit Line ( dBμV/m )	Read Level ( dBμV )	Antenna Factor ( dB/m )	Cable Loss ( dB )	Preamp Factor ( dB )	Ant Pos ( cm )	Table Pos ( deg )	Peak Avg. (P/A)	Pol. (H/V)
802.11b CH 01 2412MHz		2328.06	54.92	-19.08	74	50.72	31.98	7.18	34.96	112	242	P	H
		2390	43.89	-10.11	54	39.37	32.19	7.31	34.98	112	242	A	H
	*	2412	103.87	-	-	99.3	32.24	7.31	34.98	112	242	P	H
	*	2412	100.69	-	-	96.12	32.24	7.31	34.98	112	242	A	H
		2325.855	54.9	-19.1	74	50.7	31.98	7.18	34.96	366	174	P	V
		2388.75	43.77	-10.23	54	39.24	32.19	7.31	34.97	366	174	A	V
	*	2412	101.01	-	-	96.44	32.24	7.31	34.98	366	174	P	V
	*	2412	97.96	-	-	93.39	32.24	7.31	34.98	366	174	A	V
802.11b CH 06 2437MHz		2334.78	55.01	-18.99	74	50.76	32.03	7.18	34.96	104	245	P	H
		2386.44	43.76	-10.24	54	39.23	32.19	7.31	34.97	104	245	A	H
	*	2437	103.81	-	-	99.1	32.34	7.36	34.99	104	245	P	H
	*	2437	100.79	-	-	96.08	32.34	7.36	34.99	104	245	A	H
		2488.03	55.07	-18.93	74	50.17	32.5	7.4	35	104	245	P	H
		2484.95	44.19	-9.81	54	39.34	32.45	7.4	35	104	245	A	H
		2351.72	54.41	-19.59	74	50.05	32.09	7.24	34.97	362	184	P	V
		2387.98	43.74	-10.26	54	39.21	32.19	7.31	34.97	362	184	A	V
	*	2437	104.19	-	-	99.48	32.34	7.36	34.99	362	184	P	V
	*	2437	101.21	-	-	96.5	32.34	7.36	34.99	362	184	A	V
		2489.43	55.16	-18.84	74	50.26	32.5	7.4	35	362	184	P	V
		2490.62	44.18	-9.82	54	39.28	32.5	7.4	35	362	184	A	V



802.11b CH 11 2462MHz	*	2462	100.97	-	-	96.16	32.4	7.4	34.99	100	246	P	H
	*	2462	97.84	-	-	93.03	32.4	7.4	34.99	100	246	A	H
		2490.68	54.84	-19.16	74	49.94	32.5	7.4	35	100	246	P	H
		2483.52	44.23	-9.77	54	39.38	32.45	7.4	35	100	246	A	H
	*	2462	100.96	-	-	96.15	32.4	7.4	34.99	346	188	P	V
	*	2462	97.83	-	-	93.02	32.4	7.4	34.99	346	188	A	V
		2490.16	54.8	-19.2	74	49.9	32.5	7.4	35	346	188	P	V
		2483.52	44.53	-9.47	54	39.68	32.45	7.4	35	346	188	A	V
Remark	1. No other spurious found. 2. All results are PASS against Peak and Average limit line.												



2.4GHz 2400~2483.5MHz

WIFI 802.11b (Harmonic @ 3m)

WIFI Ant. 1	Note	Frequency ( MHz )	Level ( dBμV/m )	Over Limit ( dB )	Limit Line ( dBμV/m )	Read Level ( dBμV )	Antenna Factor ( dB/m )	Cable Loss ( dB )	Preamp Factor ( dB )	Ant Pos ( cm )	Table Pos ( deg )	Peak Avg. ( P/A )	Pol. ( H/V )
802.11b CH 01 2412MHz		4824	39.38	-34.62	74	53.1	33.64	11.68	59.04	100	0	P	H
		4824	38.65	-35.35	74	52.37	33.64	11.68	59.04	100	0	P	V
802.11b CH 06 2437MHz		4874	38.03	-35.97	74	51.9	33.54	11.53	58.94	100	0	P	H
		7311	38.62	-35.38	74	48.05	34.69	13.81	57.93	100	0	P	H
		4874	38.49	-35.51	74	52.36	33.54	11.53	58.94	100	0	P	V
		7311	38.75	-35.25	74	48.18	34.69	13.81	57.93	100	0	P	V
802.11b CH 11 2462MHz		4924	39.49	-34.51	74	53.52	33.44	11.37	58.84	100	0	P	H
		7386	39.1	-34.9	74	48.74	34.47	13.95	58.06	100	0	P	H
		4924	38.88	-35.12	74	52.91	33.44	11.37	58.84	100	0	P	V
		7386	39.03	-34.97	74	48.67	34.47	13.95	58.06	100	0	P	V
Remark	1. No other spurious found. 2. All results are PASS against Peak and Average limit line.												



**2.4GHz 2400~2483.5MHz**  
**WIFI 802.11g (Band Edge @ 3m)**

WIFI Ant. 1	Note	Frequency ( MHz )	Level ( dBμV/m )	Over Limit ( dB )	Limit Line ( dBμV/m )	Read Level ( dBμV )	Antenna Factor ( dB/m )	Cable Loss ( dB )	Preamp Factor ( dB )	Ant Pos ( cm )	Table Pos ( deg )	Peak Avg. ( P/A )	Pol. ( H/V )
802.11g CH 01 2412MHz		2325.75	54.07	-19.93	74	49.87	31.98	7.18	34.96	112	244	P	H
		2389.065	44.9	-9.1	54	40.37	32.19	7.31	34.97	112	244	A	H
	*	2412	103.97	-	-	99.4	32.24	7.31	34.98	112	244	P	H
	*	2412	96.36	-	-	91.79	32.24	7.31	34.98	112	244	A	H
		2331.315	54.64	-19.36	74	50.44	31.98	7.18	34.96	323	172	P	V
		2388.96	44.63	-9.37	54	40.1	32.19	7.31	34.97	323	172	A	V
	*	2412	99.72	-	-	95.15	32.24	7.31	34.98	323	172	P	V
	*	2412	92.62	-	-	88.05	32.24	7.31	34.98	323	172	A	V
802.11g CH 06 2437MHz		2375.66	54.84	-19.16	74	50.43	32.14	7.24	34.97	103	242	P	H
		2389.94	44.68	-9.32	54	40.16	32.19	7.31	34.98	103	242	A	H
	*	2437	103.63	-	-	98.92	32.34	7.36	34.99	103	242	P	H
	*	2437	96.42	-	-	91.71	32.34	7.36	34.99	103	242	A	H
		2496.92	55.79	-18.21	74	50.9	32.5	7.4	35.01	103	242	P	H
		2484.32	45.25	-8.75	54	40.4	32.45	7.4	35	103	242	A	H
		2379.3	54.54	-19.46	74	50.13	32.14	7.24	34.97	362	188	P	V
		2385.18	44.58	-9.42	54	40.1	32.14	7.31	34.97	362	188	A	V
	*	2437	103.31	-	-	98.6	32.34	7.36	34.99	362	188	P	V
	*	2437	95.83	-	-	91.12	32.34	7.36	34.99	362	188	A	V
		2499.72	54.76	-19.24	74	49.87	32.5	7.4	35.01	362	188	P	V
		2487.26	45.17	-8.83	54	40.32	32.45	7.4	35	362	188	A	V
802.11g CH 11 2462MHz	*	2462	100.9	-	-	96.09	32.4	7.4	34.99	100	242	P	H
	*	2462	93.26	-	-	88.45	32.4	7.4	34.99	100	242	A	H
		2483.6	55.55	-18.45	74	50.7	32.45	7.4	35	100	242	P	H
		2483.76	45.55	-8.45	54	40.7	32.45	7.4	35	100	242	A	H
	*	2462	99.99	-	-	95.18	32.4	7.4	34.99	342	186	P	V
	*	2462	92.39	-	-	87.58	32.4	7.4	34.99	342	186	A	V
		2483.52	56.05	-17.95	74	51.2	32.45	7.4	35	342	186	P	V
		2483.52	46.02	-7.98	54	41.17	32.45	7.4	35	342	186	A	V
Remark	1. No other spurious found. 2. All results are PASS against Peak and Average limit line.												



2.4GHz 2400~2483.5MHz

WIFI 802.11g (Harmonic @ 3m)

WIFI Ant. 1	Note	Frequency ( MHz )	Level ( dBμV/m )	Over Limit ( dB )	Limit Line ( dBμV/m )	Read Level ( dBμV )	Antenna Factor ( dB/m )	Cable Loss ( dB )	Preamp Factor ( dB )	Ant Pos ( cm )	Table Pos ( deg )	Peak Avg. ( P/A )	Pol. ( H/V )
802.11g CH 01 2412MHz		4824	39.7	-34.3	74	53.42	33.64	11.68	59.04	100	0	P	H
		4824	39.19	-34.81	74	52.91	33.64	11.68	59.04	100	0	P	V
802.11g CH 06 2437MHz		4874	38.83	-35.17	74	52.7	33.54	11.53	58.94	100	0	P	H
		7311	39.16	-34.84	74	48.59	34.69	13.81	57.93	100	0	P	H
		4874	39.64	-34.36	74	53.51	33.54	11.53	58.94	100	0	P	V
		7311	39.75	-34.25	74	49.18	34.69	13.81	57.93	100	0	P	V
802.11g CH 11 2462MHz		4924	38.79	-35.21	74	52.82	33.44	11.37	58.84	100	0	P	H
		7386	38.79	-35.21	74	48.43	34.47	13.95	58.06	100	0	P	H
		4924	39.67	-34.33	74	53.7	33.44	11.37	58.84	100	0	P	V
		7386	39.57	-34.43	74	49.21	34.47	13.95	58.06	100	0	P	V
Remark	1. No other spurious found. 2. All results are PASS against Peak and Average limit line.												





**2.4GHz 2400~2483.5MHz  
WIFI 802.11n HT20 (Band Edge @ 3m)**

WIFI Ant. 1	Note	Frequency ( MHz )	Level ( dBμV/m )	Over Limit ( dB )	Limit Line ( dBμV/m )	Read Level ( dBμV )	Antenna Factor ( dB/m )	Cable Loss ( dB )	Preamp Factor ( dB )	Ant Pos ( cm )	Table Pos ( deg )	Peak Avg. ( P/A )	Pol. ( H/V )
802.11n HT20 CH 01 2412MHz		2387.385	53.95	-20.05	74	49.42	32.19	7.31	34.97	112	241	P	H
		2389.59	45.1	-8.9	54	40.57	32.19	7.31	34.97	112	241	A	H
	*	2412	103.5	-	-	98.93	32.24	7.31	34.98	112	241	P	H
	*	2412	95.23	-	-	90.66	32.24	7.31	34.98	112	241	A	H
		2377.2	54.16	-19.84	74	49.75	32.14	7.24	34.97	367	185	P	V
		2389.905	44.98	-9.02	54	40.46	32.19	7.31	34.98	367	185	A	V
	*	2412	101.45	-	-	96.88	32.24	7.31	34.98	367	185	P	V
	*	2412	94.46	-	-	89.89	32.24	7.31	34.98	367	185	A	V
802.11n HT20 CH 06 2437MHz		2312.1	54.6	-19.4	74	50.44	31.93	7.18	34.95	108	242	P	H
		2389.38	44.76	-9.24	54	40.23	32.19	7.31	34.97	108	242	A	H
	*	2437	103.82	-	-	99.11	32.34	7.36	34.99	108	242	P	H
	*	2437	95.87	-	-	91.16	32.34	7.36	34.99	108	242	A	H
		2484.67	54.94	-19.06	74	50.09	32.45	7.4	35	108	242	P	H
		2487.26	45.39	-8.61	54	40.54	32.45	7.4	35	108	242	A	H
		2331.7	54.14	-19.86	74	49.94	31.98	7.18	34.96	362	185	P	V
		2370.76	44.58	-9.42	54	40.17	32.14	7.24	34.97	362	185	A	V
	*	2437	103.64	-	-	98.93	32.34	7.36	34.99	362	185	P	V
	*	2437	96.39	-	-	91.68	32.34	7.36	34.99	362	185	A	V
	2491.46	55.4	-18.6	74	50.5	32.5	7.4	35	362	185	P	V	
	2489.85	45.37	-8.63	54	40.47	32.5	7.4	35	362	185	A	V	
802.11n HT20 CH 11 2462MHz	*	2462	100.01	-	-	95.2	32.4	7.4	34.99	100	243	P	H
	*	2462	92.39	-	-	87.58	32.4	7.4	34.99	100	243	A	H
		2483.68	56.64	-17.36	74	51.79	32.45	7.4	35	100	243	P	H
		2483.56	45.86	-8.14	54	41.01	32.45	7.4	35	100	243	A	H
	*	2462	99.42	-	-	94.61	32.4	7.4	34.99	343	192	P	V
	*	2462	92.01	-	-	87.2	32.4	7.4	34.99	343	192	A	V
		2483.56	56.13	-17.87	74	51.28	32.45	7.4	35	343	192	P	V
	2483.56	46.58	-7.42	54	41.73	32.45	7.4	35	343	192	A	V	
<b>Remark</b>	1. No other spurious found. 2. All results are PASS against Peak and Average limit line.												



**2.4GHz 2400~2483.5MHz  
WIFI 802.11n HT20 (Harmonic @ 3m)**

WIFI Ant. 1	Note	Frequency ( MHz )	Level ( dBμV/m )	Over Limit ( dB )	Limit Line ( dBμV/m )	Read Level ( dBμV )	Antenna Factor ( dB/m )	Cable Loss ( dB )	Preamp Factor ( dB )	Ant Pos ( cm )	Table Pos ( deg )	Peak Avg. ( P/A )	Pol. ( H/V )
802.11n HT20 CH 01 2412MHz		4824	39.23	-34.77	74	52.95	33.64	11.68	59.04	100	0	P	H
		4824	40.09	-33.91	74	53.81	33.64	11.68	59.04	100	0	P	V
802.11n HT20 CH 06 2437MHz		4874	38.8	-35.2	74	52.67	33.54	11.53	58.94	100	0	P	H
		7311	40.23	-33.77	74	49.66	34.69	13.81	57.93	100	0	P	H
		4874	39.21	-34.79	74	53.08	33.54	11.53	58.94	100	0	P	V
		7311	39.61	-34.39	74	49.04	34.69	13.81	57.93	100	0	P	V
802.11n HT20 CH 11 2462MHz		4924	39.01	-34.99	74	53.04	33.44	11.37	58.84	100	0	P	H
		7386	38.74	-35.26	74	48.38	34.47	13.95	58.06	100	0	P	H
		4924	38.56	-35.44	74	52.59	33.44	11.37	58.84	100	0	P	V
		7386	38.94	-35.06	74	48.58	34.47	13.95	58.06	100	0	P	V
Remark	1. No other spurious found. 2. All results are PASS against Peak and Average limit line.												



Emission below 1GHz

2.4GHz WIFI 802.11n HT20 (LF)

WIFI Ant. 1	Note	Frequency ( MHz )	Level ( dBμV/m )	Over Limit ( dB )	Limit Line ( dBμV/m )	Read Level (dBμV)	Antenna Factor ( dB/m )	Cable Loss ( dB )	Preamp Factor ( dB )	Ant Pos ( cm )	Table Pos ( deg )	Peak Avg. (P/A)	Pol. (H/V)
2.4GHz 802.11n HT20 LF		30	27.53	-12.47	40	31.81	26	1.07	31.35	-	-	P	H
		175.53	31.26	-12.24	43.5	45.3	15.67	1.78	31.49	100	0	P	H
		275.16	23.6	-22.4	46	33.25	19.35	2.32	31.32	-	-	P	H
		505.8	26.4	-19.6	46	30.02	24.25	3.14	31.01	-	-	P	H
		841.1	31.6	-14.4	46	29.55	28.52	4.1	30.57	-	-	P	H
		965	33.74	-20.26	54	29.97	30.23	4.07	30.53	-	-	P	H
		62.13	34.99	-5.01	40	53.15	12.14	1.28	31.58	100	0	P	V
		174.72	37.52	-5.98	43.5	51.5	15.73	1.78	31.49	-	-	P	V
		294.33	27.07	-18.93	46	36.28	19.75	2.32	31.28	-	-	P	V
		386.1	25.9	-20.1	46	32.34	22.07	2.67	31.18	-	-	P	V
		801.9	30.59	-15.41	46	29.54	27.74	3.9	30.59	-	-	P	V
	953.8	33.22	-12.78	46	29.47	30.21	4.07	30.53	-	-	P	V	
Remark	1. No other spurious found. 2. All results are PASS against limit line.												



**Note symbol**

*	<b>Fundamental Frequency</b> which can be ignored. However, the level of any unwanted emissions shall not exceed the level of the fundamental frequency.
!	Test result is <b>over limit</b> line.
P/A	<b>Peak</b> or <b>Average</b>
H/V	<b>Horizontal</b> or <b>Vertical</b>



A calculation example for radiated spurious emission is shown as below:

WIFI Ant. 1	Note	Frequency ( MHz )	Level ( dBμV/m )	Over Limit ( dB )	Limit Line ( dBμV/m )	Read Level ( dBμV )	Antenna Factor ( dB/m )	Cable Loss ( dB )	Preamp Factor ( dB )	Ant Pos ( cm )	Table Pos ( deg )	Peak Avg. ( P/A )	Pol. ( H/V )
802.11b CH 01 2412MHz		2390	55.45	-18.55	74	54.51	32.22	4.58	35.86	103	308	P	H
		2390	43.54	-10.46	54	42.6	32.22	4.58	35.86	103	308	A	H

- Level(dBμV/m) =  
Antenna Factor(dB/m) + Cable Loss(dB) + Read Level(dBμV) - Preamp Factor(dB)
- Over Limit(dB) = Level(dBμV/m) – Limit Line(dBμV/m)

**For Peak Limit @ 2390MHz:**

- Level(dBμV/m)  
= Antenna Factor(dB/m) + Cable Loss(dB) + Read Level(dBμV) - Preamp Factor(dB)  
= 32.22(dB/m) + 4.58(dB) + 54.51(dBμV) – 35.86 (dB)  
= 55.45 (dBμV/m)
- Over Limit(dB)  
= Level(dBμV/m) – Limit Line(dBμV/m)  
= 55.45(dBμV/m) – 74(dBμV/m)  
= -18.55(dB)

**For Average Limit @ 2390MHz:**

- Level(dBμV/m)  
= Antenna Factor(dB/m) + Cable Loss(dB) + Read Level(dBμV) - Preamp Factor(dB)  
= 32.22(dB/m) + 4.58(dB) + 42.6(dBμV) – 35.86 (dB)  
= 43.54 (dBμV/m)
- Over Limit(dB)  
= Level(dBμV/m) – Limit Line(dBμV/m)  
= 43.54(dBμV/m) – 54(dBμV/m)  
= -10.46(dB)

Both peak and average measured complies with the limit line, so test result is “PASS”.



## Appendix C. Duty Cycle Plots

Antenna	Band	Duty Cycle(%)	T(ms)	1/T(kHz)	VBW Setting
1	802.11b	100	-	-	10Hz
1	802.11g	97.22	1.400	0.714	1kHz
1	802.11n HT20	97.02	1.300	0.769	1kHz



802.11b

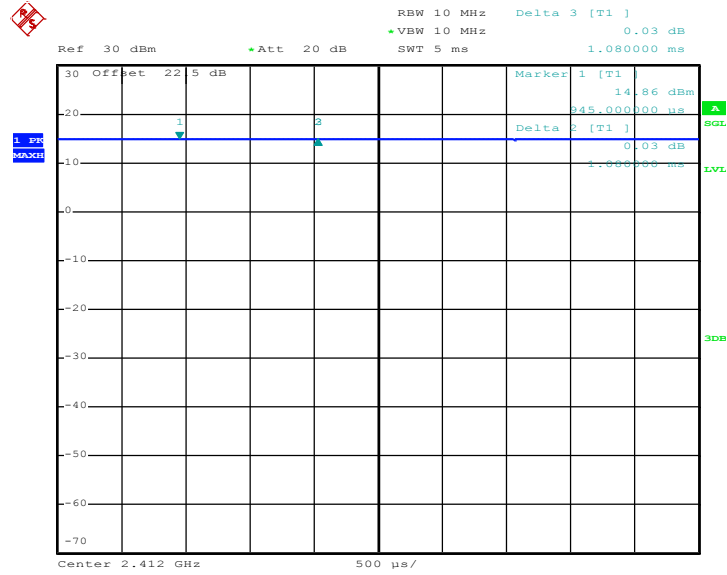

802.11g

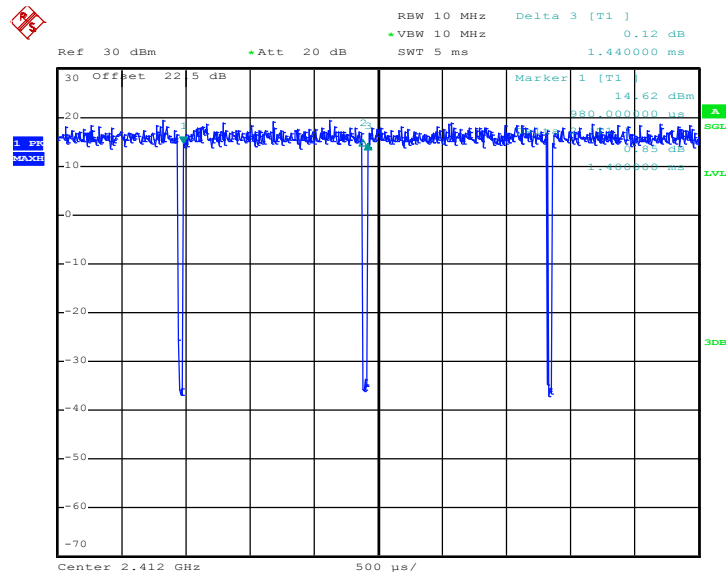



802.11n20



RBW 10 MHz Delta 3 [T1 ]  
+VBW 10 MHz -0.12 dB  
Ref 30 dBm +Att 20 dB SWT 5 ms 1.340000 ms

