



FCC RF Test Report

APPLICANT : HMD Global Oy
EQUIPMENT : Smart Phone
BRAND NAME : NOKIA
MODEL NAME : TA-1032
FCC ID : 2AJOTTA-1032
STANDARD : 47 CFR Part 2, 22(H), 27(M)
CLASSIFICATION : PCS Licensed Transmitter Held to Ear (PCE)

The product was received on Jan. 13, 2017 and completely tested on Jan. 23, 2017. We, SPORTON INTERNATIONAL (KUNSHAN) INC., would like to declare that the tested sample has been evaluated in accordance with the test procedures given in ANSI / TIA / EIA-603-D-2010 and the testing has shown the tested sample to be in compliance with the applicable technical standards.

The test results in this report apply exclusively to the tested model / sample. Without written approval of SPORTON INTERNATIONAL (KUNSHAN) INC., the test report shall not be reproduced except in full.

Prepared by: James Huang / Manager

Approved by: Jones Tsai / Manager



SPORTON INTERNATIONAL (KUNSHAN) INC.
No. 3-2, PingXiang Road, Kunshan, Jiangsu Province, P. R. China



TABLE OF CONTENTS

REVISION HISTORY.....3
SUMMARY OF TEST RESULT4
1 GENERAL DESCRIPTION5
1.1 Applicant5
1.2 Manufacturer.....5
1.3 Product Feature of Equipment Under Test.....5
1.4 Product Specification of Equipment Under Test.....6
1.5 Modification of EUT6
1.6 Re-use of Measured Data7
1.7 Maximum ERP Power, Frequency Tolerance, and Emission Designator8
1.8 Testing Location9
1.9 Applicable Standards.....9
2 TEST CONFIGURATION OF EQUIPMENT UNDER TEST10
2.1 Test Mode10
2.2 Connection Diagram of Test System.....11
2.3 Support Unit used in test configuration and system11
2.4 Measurement Results Explanation Example.....11
2.5 Frequency List of Low/Middle/High Channels12
3 CONDUCTED TEST ITEMS13
3.1 Measuring Instruments13
3.2 Test Setup13
3.3 Test Result of Conducted Test13
3.4 Conducted Output Power and ERP.....14
3.5 Peak-to-Average Ratio15
3.6 Occupied Bandwidth.....16
3.7 Conducted Band Edge17
3.8 Conducted Spurious Emission18
3.9 Frequency Stability19
4 RADIATED TEST ITEMS20
4.1 Measuring Instruments20
4.2 Test Setup20
4.3 Test Result of Radiated Test20
4.4 Radiated Spurious Emission21
5 LIST OF MEASURING EQUIPMENT22
6 UNCERTAINTY OF EVALUATION23
APPENDIX A. TEST RESULTS OF CONDUCTED TEST
APPENDIX B. TEST RESULTS OF RADIATED TEST
APPENDIX C. TEST SETUP PHOTOGRAPHS
APPENDIX D. PRODUCT EQUALITY DECLARATION
APPENDIX E. REFERENCE REPORT



REVISION HISTORY

REPORT NO.	VERSION	DESCRIPTION	ISSUED DATE
FG711304B	Rev. 01	Initial issue of report	Mar. 15, 2017



SUMMARY OF TEST RESULT

Report Section	FCC Rule	Description	Limit	Result	Remark
3.4	§2.1046	Conducted Output Power	Reporting Only	PASS	-
	§22.913(a)(2)	Effective Radiated Power (Band 5)	ERP < 7 Watt	PASS	-
3.5	N/A	Peak-to-Average Ratio	<13 dB	PASS	-
3.6	§2.1049	Occupied Bandwidth	Reporting Only	PASS	-
3.7	§2.1051 §22.917(a)	Conducted Band Edge Measurement (Band 5)	< 43+10log ₁₀ (P[Watts])	PASS	-
3.8	§2.1051 §22.917(a)	Conducted Spurious Emission (Band 5)	< 43+10log ₁₀ (P[Watts])	PASS	-
3.9	§2.1055 §22.355	Frequency Stability Temperature & Voltage	< 2.5 ppm for Part 22H	PASS	-
4.4	§2.1053 §22.917(a)	Radiated Spurious Emission (Band 5)	< 43+10log ₁₀ (P[Watts])	PASS	Under limit 28.15 dB at 1664.000 MHz



1 General Description

1.1 Applicant

HMD Global Oy
Karaportti 2, 02610 Espoo, Finland

1.2 Manufacturer

HMD Global Oy
Karaportti 2, 02610 Espoo, Finland

1.3 Product Feature of Equipment Under Test

Product Feature	
Equipment	Smart Phone
Brand Name	NOKIA
Model Name	TA-1032
FCC ID	2AJOTTA-1032
EUT supports Radios application	GSM/GPRS/EGPRS/WCDMA/HSPA/ HSPA+/DC-HSDPA/LTE/NFC WLAN2.4GHz 802.11b/g/n HT20 WLAN5GHz 802.11a/n HT20/HT40 Bluetooth v3.0 + EDR / Bluetooth v4.0 LE / Bluetooth v4.1 LE / Bluetooth v4.2 LE
IMEI Code	Conducted: 356805080008453/356805080008446 Radiation: 356805080006556/356805080006549
HW Version	DVT1.5
SW Version	000C_1_26A
EUT Stage	Production Unit



1.4 Product Specification of Equipment Under Test

Standards-related Product Specification	
Tx Frequency	LTE Band 5 : 824.7 MHz ~ 848.3 MHz LTE Band 7 : 2502.5 MHz ~ 2567.5 MHz LTE Band 38 : 2572.5 MHz ~ 2617.5 MHz
Rx Frequency	LTE Band 5 : 869.7 MHz ~ 893.3 MHz LTE Band 7 : 2622.5 MHz ~ 2687.5 MHz LTE Band 38 : 2572.5 MHz ~ 2617.5 MHz
Bandwidth	LTE Band 5 : 1.4MHz / 3MHz / 5MHz / 10MHz LTE Band 7 : 5MHz / 10MHz / 15MHz / 20MHz LTE Band 38 : 5MHz / 10MHz / 15MHz / 20MHz
Maximum Output Power to Antenna	LTE Band 5 : 24.26 dBm
Antenna Gain	LTE Band 5 : -0.63 dBi
Type of Modulation	QPSK / 16QAM

1.5 Modification of EUT

No modifications are made to the EUT during all test items.



1.6 Re-use of Measured Data

1.6.1 Introduction Section

This application re-uses data collected on a similar device. The subject device of this application (Model: TA-1032, FCC ID: 2AJOTTA-1032) is electrically identical to the reference device (Model: TA-1038, FCC ID: 2AJOTTA-1038) for the portions of the circuitry corresponding to the data being re-used, as treated by KDB Publication 178919 D01.

1.6.2 Difference Section

For details concerning the similarity with respect to component placement, mechanical/electrical design etc., please refer to the Product Equality Declaration as Appendix E.

The re-used RF data includes the following bands provided in Appendix A (Sporton RF Report No. FG711304-01B for the reference device Model: TA-1038, FCC ID: 2AJOTTA-1038):

1.6.3 Spot Check Verification Data Section

In order to confirm hardware similarity of the subject device with the reference device, spot check measurements were performed on the subject device for radiated spurious emission, the test result were consistent with FCC ID: 2AJOTTA-1038 and added LTE Band 5 to full test.

Assertions concerning the similarity of these devices are based on representations by the applicant. The applicant accepts full responsibility for the validity of the similarity claim, and for the determination that verification test data are sufficient to support it.

1.6.4 Reference detail Section:

Equipment Class	Reference FCC ID	Folder Test/RF Exposure	Report Title/Section
PCE (LTE)	2AJOTTA-1038	Part27M (FG711304-01B)	All sections applicable for LTE Band 7/38.



1.7 Maximum ERP Power, Frequency Tolerance, and Emission Designator

LTE Band 5		QPSK			16QAM		
BW (MHz)	Frequency Range (MHz)	Emission Designator (99%OBW)	Frequency Tolerance (ppm)	Maximum ERP(W)	Emission Designator (99%OBW)	Frequency Tolerance (ppm)	Maximum ERP(W)
1.4	824.7 ~ 848.3	1M10G7D	-	0.1406	1M10W7D	-	0.1178
3	825.5 ~ 847.5	2M73G7D	-	0.1380	2M73W7D	-	0.1164
5	826.5 ~ 846.5	4M52G7D	-	0.1387	4M51W7D	-	0.1175
10	829.0 ~ 844.0	9M11G7D	0.0026	0.1380	9M07W7D	-	0.1178



1.8 Testing Location

Test Site	SPORTON INTERNATIONAL (KUNSHAN) INC.		
Test Site Location	No. 3-2, PingXiang Road, Kunshan, Jiangsu Province, P. R. China TEL: +86-0512-5790-0158 FAX: +86-0512-5790-0958		
Test Site No.	Sporton Site No.		FCC Registration No.
	TH01-KS	03CH03-KS	306251

1.9 Applicable Standards

According to the specifications of the manufacturer, the EUT must comply with the requirements of the following standards:

- ♦ 47 CFR Part 2, 22(H), 27(M)
- ♦ ANSI / TIA / EIA-603-D-2010
- ♦ FCC KDB 971168 D01 Power Meas. License Digital Systems v02r02
- ♦ FCC KDB 412172 D01 Determining ERP and EIRP v01r01

Remark:

1. All test items were verified and recorded according to the standards and without any deviation during the test.
2. This EUT has also been tested and complied with the requirements of FCC Part 15, Subpart B, recorded in a separate test report.



2 Test Configuration of Equipment Under Test

2.1 Test Mode

Antenna port conducted and radiated test items listed below are performed according to KDB 971168 D01 Power Meas. License Digital Systems v02r02 with maximum output power.

Radiated measurements are performed by rotating the EUT in three different orthogonal test planes to find the maximum emission.

Test Items	Band	Bandwidth (MHz)						Modulation		RB #			Test Channel		
		1.4	3	5	10	15	20	QPSK	16QAM	1	Half	Full	L	M	H
Max. Output Power	5	v	v	v	v	-	-	v	v	v	v	v	v	v	v
Peak-to-Average Ratio	5				v	-	-	v	v	v		v	v	v	v
26dB and 99% Bandwidth	5	v	v	v	v	-	-	v	v			v	v	v	v
Conducted Band Edge	5	v	v	v	v	-	-	v	v	v		v	v		v
Conducted Spurious Emission	5	v	v	v	v	-	-	v	v	v			v	v	v
Frequency Stability	5				v	-	-	v				v		v	
E.R.P.	5	v	v	v	v	-	-	v	v	v			v	v	v
Radiated Spurious Emission	5	v	v	v	v	-	-	v		v				v	
Note	<ol style="list-style-type: none"> The mark "v " means that this configuration is chosen for testing The mark "- " means that this bandwidth is not supported. The device is investigated from 30MHz to 10 times of fundamental signal for radiated spurious emission test under different RB size/offset and modulations in exploratory test. Subsequently, only the worst case emissions are reported. 														

2.2 Connection Diagram of Test System

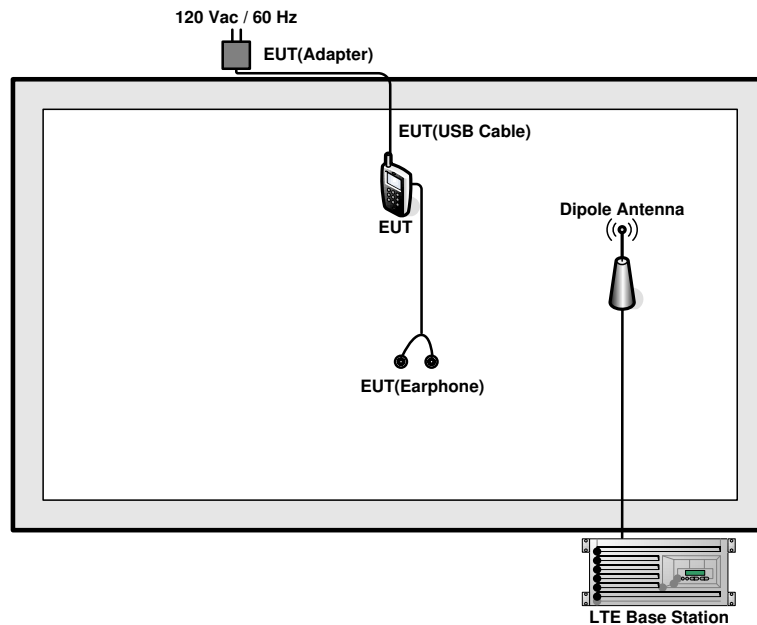

2.3 Support Unit used in test configuration and system

Item	Equipment	Trade Name	Model No.	FCC ID	Data Cable	Power Cord
1.	LTE Base Station	Anritsu	MT8820C	N/A	N/A	Unshielded, 1.8 m
2.	DC Power Supply	GW INSTEK	GPS-3030D	N/A	N/A	Unshielded, 1.8 m

2.4 Measurement Results Explanation Example

For all conducted test items:

The offset level is set in the spectrum analyzer to compensate the RF cable loss between EUT conducted output port and spectrum analyzer. With the offset compensation, the spectrum analyzer reading level is exactly the EUT RF output level.

The spectrum analyzer offset is derived from RF cable loss.

Offset = RF cable loss.

Following shows an offset computation example with cable loss 4.41 dB.

Example :

Offset(dB) = RF cable loss(dB).

= 4.41 (dB)



2.5 Frequency List of Low/Middle/High Channels

LTE Band 5 Channel and Frequency List				
BW [MHz]	Channel/Frequency(MHz)	Lowest	Middle	Highest
10	Channel	20450	20525	20600
	Frequency	829	836.5	844
5	Channel	20425	20525	20625
	Frequency	826.5	836.5	846.5
3	Channel	20415	20525	20635
	Frequency	825.5	836.5	847.5
1.4	Channel	20407	20525	20643
	Frequency	824.7	836.5	848.3

3 Conducted Test Items

3.1 Measuring Instruments

See list of measuring instruments of this test report.

3.2 Test Setup

3.2.1 Conducted Output Power

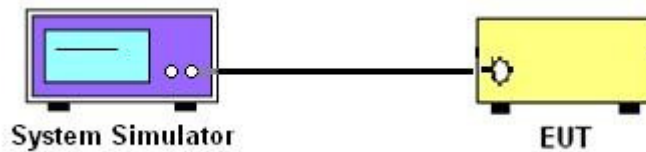

3.2.2 Peak-to-Average Ratio, Occupied Bandwidth ,Conducted Band-Edge and Conducted Spurious Emission

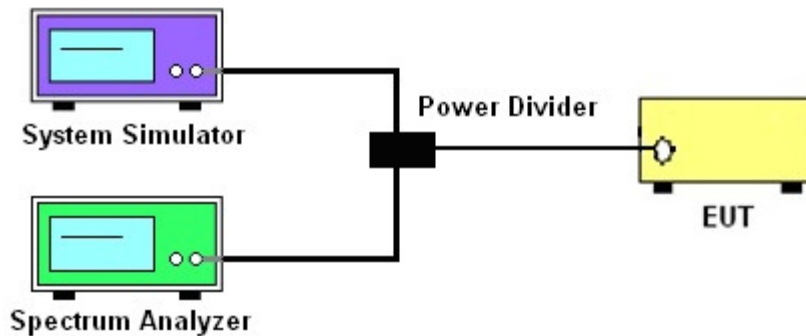

3.2.3 Frequency Stability

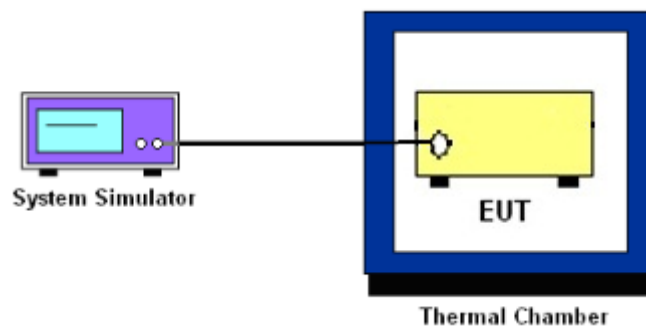

3.3 Test Result of Conducted Test

Please refer to Appendix A.



3.4 Conducted Output Power and ERP

3.4.1 Description of the Conducted Output Power Measurement and ERP Measurement

A system simulator was used to establish communication with the EUT. Its parameters were set to force the EUT transmitting at maximum output power. The measured power in the radio frequency on the transmitter output terminals shall be reported.

The ERP of mobile transmitters must not exceed 7 Watts for LTE Band 5.

According to KDB 412172 D01 Power Approach,

$EIRP = P_T + G_T - L_C$, $ERP = EIRP - 2.15$, where

P_T = transmitter output power in dBm

G_T = gain of the transmitting antenna in dBi

L_C = signal attenuation in the connecting cable between the transmitter and antenna in dB

3.4.2 Test Procedures

1. The transmitter output port was connected to the system simulator.
2. Set EUT at maximum power through the system simulator.
3. Select lowest, middle, and highest channels for each band and different modulation.
4. Measure and record the power level from the system simulator.



3.5 Peak-to-Average Ratio

3.5.1 Description of the PAR Measurement

Power Complementary Cumulative Distribution Function (CCDF) curves provide a means for characterizing the power peaks of a digitally modulated signal on a statistical basis. A CCDF curve depicts the probability of the peak signal amplitude exceeding the average power level. Most contemporary measurement instrumentation include the capability to produce CCDF curves for an input signal provided that the instrument's resolution bandwidth can be set wide enough to accommodate the entire input signal bandwidth. In measuring transmissions in this band using an average power technique, the peak-to-average ratio (PAR) of the transmission may not exceed 13 dB.

3.5.2 Test Procedures

1. The testing follows FCC KDB 971168 v02r02 Section 5.7.1.
2. The EUT was connected to spectrum and system simulator via a power divider.
3. Set the CCDF (Complementary Cumulative Distribution Function) option in spectrum analyzer.
4. The highest RF powers were measured and recorded the maximum PAPR level associated with a probability of 0.1 %.
5. Record the deviation as Peak to Average Ratio.



3.6 Occupied Bandwidth

3.6.1 Description of Occupied Bandwidth Measurement

The occupied bandwidth is the width of a frequency band such that, below the lower and above the upper frequency limits, the mean powers emitted are each equal to a specified percentage 0.5% of the total mean transmitted power.

The 26 dB emission bandwidth is defined as the frequency range between two points, one above and one below the carrier frequency, at which the spectral density of the emission is attenuated 26 dB below the maximum in-band spectral density of the modulated signal. Spectral density (power per unit bandwidth) is to be measured with a detector of resolution bandwidth equal to approximately 1.0% of the emission bandwidth.

3.6.2 Test Procedures

1. The testing follows FCC KDB 971168 v02r02 Section 4.2.
2. The EUT was connected to spectrum analyzer and system simulator via a power divider.
3. The spectrum analyzer center frequency is set to the nominal EUT channel center frequency. The span range for the spectrum analyzer shall be between two and five times the anticipated OBW.
4. The nominal resolution bandwidth (RBW) shall be in the range of 1 to 5 % of the anticipated OBW, and the VBW shall be at least 3 times the RBW.
5. Set the detection mode to peak, and the trace mode to max hold.
6. Determine the reference value: Set the EUT to transmit a modulated signal. Allow the trace to stabilize. Set the spectrum analyzer marker to the highest level of the displayed trace.
(this is the reference value)
7. Determine the “-26 dB down amplitude” as equal to (Reference Value – X).
8. Place two markers, one at the lowest and the other at the highest frequency of the envelope of the spectral display such that each marker is at or slightly below the “-X dB down amplitude” determined in step 6. If a marker is below this “-X dB down amplitude” value it shall be placed as close as possible to this value. The OBW is the positive frequency difference between the two markers.
9. Use the 99 % power bandwidth function of the spectrum analyzer and report the measured bandwidth.



3.7 Conducted Band Edge

3.7.1 Description of Conducted Band Edge Measurement

22.917(a)

For operations in the 824 – 849 MHz band, the FCC limit is $43 + 10\log_{10}(P[\text{Watts}])$ dB below the transmitter power P(Watts) in a 100kHz bandwidth. However, in the 1MHz bands immediately outside and adjacent to the licensee's frequency block, a resolution bandwidth of at least one percent of the emission bandwidth of the fundamental emission of the transmitter may be employed.

3.7.2 Test Procedures

1. The testing follows FCC KDB 971168 v02r02 Section 6.0.
2. The EUT was connected to spectrum analyzer and system simulator via a power divider.
3. The band edges of low and high channels for the highest RF powers were measured.
4. Set RBW $\geq 1\%$ EBW in the 1MHz band immediately outside and adjacent to the band edge.
5. Beyond the 1 MHz band from the band edge, RBW=1MHz was used.
6. Set spectrum analyzer with RMS detector.
7. The RF fundamental frequency should be excluded against the limit line in the operating frequency band.
8. Checked that all the results comply with the emission limit line.

Example:

The limit line is derived from $43 + 10\log(P)$ dB below the transmitter power P(Watts)
= P(W)- [43 + 10log(P)] (dB)
= [30 + 10log(P)] (dBm) - [43 + 10log(P)] (dB) = -13dBm.



3.8 Conducted Spurious Emission

3.8.1 Description of Conducted Spurious Emission Measurement

The power of any emission outside of the authorized operating frequency ranges must be lower than the transmitter power (P) by a factor of at least $43 + 10 \log (P)$ dB.

It is measured by means of a calibrated spectrum analyzer and scanned from 30 MHz up to a frequency including its 10th harmonic.

3.8.2 Test Procedures

1. The testing follows FCC KDB 971168 v02r02 Section 6.0.
2. The EUT was connected to spectrum analyzer and system simulator via a power divider.
3. The RF output of EUT was connected to the spectrum analyzer by RF cable and attenuator. The path loss was compensated to the results for each measurement.
4. The middle channel for the highest RF power within the transmitting frequency was measured.
5. The conducted spurious emission for the whole frequency range was taken.
6. Make the measurement with the spectrum analyzer's RBW = 1MHz, VBW = 3MHz.
7. Set spectrum analyzer with RMS detector.
8. Taking the record of maximum spurious emission.
9. The RF fundamental frequency should be excluded against the limit line in the operating frequency band.
10. The limit line is derived from $43 + 10\log(P)$ dB below the transmitter power P(Watts)
= $P(W) - [43 + 10\log(P)]$ (dB)
= $[30 + 10\log(P)]$ (dBm) - $[43 + 10\log(P)]$ (dB)
= -13dBm.



3.9 Frequency Stability

3.9.1 Description of Frequency Stability Measurement

The frequency stability shall be measured by variation of ambient temperature and variation of primary supply voltage to ensure that the fundamental emission stays within the authorized frequency block. The frequency stability of the transmitter shall be maintained within $\pm 0.00025\%$ ($\pm 2.5\text{ppm}$) of the center frequency.

3.9.2 Test Procedures for Temperature Variation

1. The testing follows FCC KDB 971168 v02r02 Section 9.0.
2. The EUT was set up in the thermal chamber and connected with the system simulator.
3. With power OFF, the temperature was decreased to -30°C and the EUT was stabilized before testing. Power was applied and the maximum change in frequency was recorded within one minute.
4. With power OFF, the temperature was raised in 10°C step up to 50°C . The EUT was stabilized at each step for at least half an hour. Power was applied and the maximum frequency change was recorded within one minute.

3.9.3 Test Procedures for Voltage Variation

1. The testing follows FCC KDB 971168 v02r02 Section 9.0.
2. The EUT was placed in a temperature chamber at $20\pm 5^{\circ}\text{C}$ and connected with the system simulator.
3. The power supply voltage to the EUT was varied from 85% to 115% of the nominal value measured at the input to the EUT.
4. The variation in frequency was measured for the worst case.

4 Radiated Test Items

4.1 Measuring Instruments

See list of measuring instruments of this test report.

4.2 Test Setup

4.2.1 For radiated test from 30MHz to 1GHz

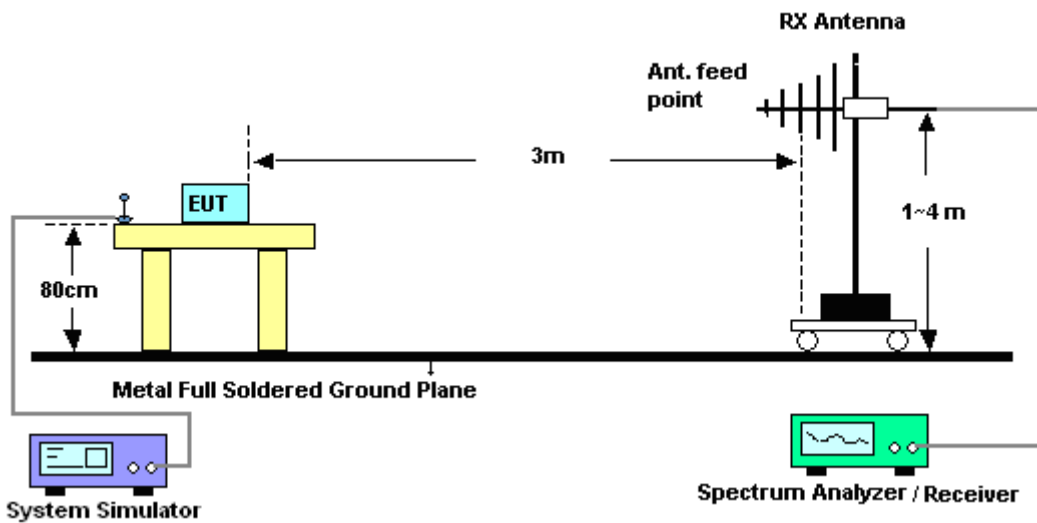

4.2.2 For radiated test above 1GHz

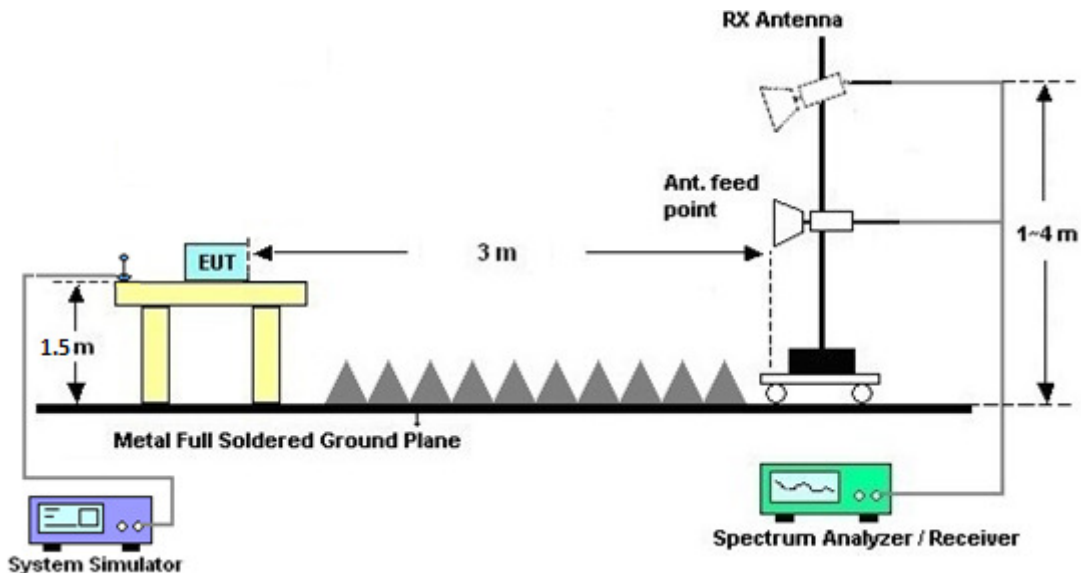

4.3 Test Result of Radiated Test

Please refer to Appendix B.



4.4 Radiated Spurious Emission

4.4.1 Description of Radiated Spurious Emission

The radiated spurious emission was measured by substitution method according to ANSI / TIA / EIA-603-D-2010. The power of any emission outside of the authorized operating frequency ranges must be attenuated below the transmitter power (P) by a factor of at least $43 + 10 \log (P)$ dB.

The spectrum is scanned from 30 MHz up to a frequency including its 10th harmonic.

4.4.2 Test Procedures

1. The testing follows FCC KDB 971168 v02r02 Section 5.8 and ANSI / TIA-603-D-2010 Section 2.2.12.
2. The EUT was placed on a rotatable wooden table 0.8 meters for frequency below 1GHz and 1.5 meter for frequency above 1GHz above the ground.
3. The EUT was set 3 meters from the receiving antenna, which was mounted on the antenna tower.
4. The table was rotated 360 degrees to determine the position of the highest spurious emission.
5. The height of the receiving antenna is varied between one meter and four meters to search the maximum spurious emission for both horizontal and vertical polarizations.
6. Make the measurement with the spectrum analyzer's RBW = 1MHz, VBW = 3MHz, taking the record of maximum spurious emission.
7. A horn antenna was substituted in place of the EUT and was driven by a signal generator.
8. Tune the output power of signal generator to the same emission level with EUT maximum spurious emission.
9. Taking the record of output power at antenna port.
10. Repeat step 7 to step 8 for another polarization.
11. The RF fundamental frequency should be excluded against the limit line in the operating frequency band.

The limit line is derived from $43 + 10\log(P)$ dB below the transmitter power P(Watts)
= P(W)- [43 + 10log(P)] (dB)
= [30 + 10log(P)] (dBm) - [43 + 10log(P)] (dB)
= -13dBm.

12. EIRP (dBm) = S.G. Power – Tx Cable Loss + Tx Antenna Gain
13. ERP (dBm) = EIRP - 2.15



5 List of Measuring Equipment

Instrument	Manufacturer	Model No.	Serial No.	Characteristics	Calibration Date	Test Date	Due Date	Remark
Spectrum Analyzer	R&S	FSV40	101040	10Hz~40GHz	Aug. 09, 2016	Jan. 19, 2017	Aug. 08, 2017	Conducted (TH01-KS)
Thermal Chamber	Ten Billion	TTC-B3S	TBN-960502	-40~+150°C	Oct. 13, 2016	Jan. 19, 2017	Oct. 12, 2017	Conducted (TH01-KS)
EXA Spectrum Analyzer	Keysight	N9010A	MY55150244	10Hz~44GHz	Apr. 22, 2016	Jan. 23, 2017	Apr. 21, 2017	Radiation (03CH03-KS)
Bilog Antenna	TeseQ	CBL6112D	35406	25MHz~2GHz	Apr. 16, 2016	Jan. 23, 2017	Apr. 15, 2017	Radiation (03CH03-KS)
Horn Antenna	Schwarzbeck	BBHA9120D	9120D-1356	1GHz~18GHz	Apr. 16, 2016	Jan. 23, 2017	Apr. 15, 2017	Radiation (03CH03-KS)
SHF-EHF Horn	Schwarzbeck	BBHA 9170	BBHA170249	15GHz~40GHz	Mar. 03, 2016	Jan. 23, 2017	Mar. 02, 2017	Radiation (03CH03-KS)
Amplifier	SONOMA	310N	187289	9kHz~1GHz	Aug. 09, 2016	Jan. 23, 2017	Aug. 08, 2017	Radiation (03CH03-KS)
High Gain Amplifier	MITEQ	AMF-7D-00 101800-30-1	1943529	1GHz~18GHz	Jan. 19, 2017	Jan. 23, 2017	Jan. 18, 2018	Radiation (03CH03-KS)
Amplifier	MITEQ	TTA1840-35 -HG	1887435	18GHz~40GHz	Oct. 13, 2016	Jan. 23, 2017	Oct. 12, 2017	Radiation (03CH03-KS)
Amplifier	Agilent	8449B	3008A02370	1GHz~26.5GHz	Oct. 13, 2016	Jan. 23, 2017	Oct. 12, 2017	Radiation (03CH03-KS)
AC Power Source	Chroma	61601	F104090004	N/A	NCR	Jan. 23, 2017	NCR	Radiation (03CH03-KS)
Turn Table	ChamPro	EM 1000-T	060762-T	0~360 degree	NCR	Jan. 23, 2017	NCR	Radiation (03CH03-KS)
Antenna Mast	ChamPro	EM 1000-A	060762-A	1 m~4 m	NCR	Jan. 23, 2017	NCR	Radiation (03CH03-KS)

NCR: No Calibration Required



6 Uncertainty of Evaluation

Uncertainty of Radiated Emission Measurement (30 MHz ~ 1000 MHz)

Measuring Uncertainty for a Level of Confidence of 95% (U = 2Uc(y))	2.8dB
---	-------

Uncertainty of Radiated Emission Measurement (1GHz ~ 40GHz)

Measuring Uncertainty for a Level of Confidence of 95% (U = 2Uc(y))	3.3dB
---	-------



Appendix A. Test Results of Conducted Test

Conducted Output Power(Average power)

LTE Band 5 Maximum Average Power [dBm]						
BW [MHz]	RB Size	RB Offset	Mod	Lowest	Middle	Highest
10	1	0	QPSK	24.18	24.13	24.17
10	1	25		24.17	24.12	24.16
10	1	49		23.15	24.04	24.13
10	25	0		23.26	23.20	23.25
10	25	12		23.24	23.00	23.22
10	25	25		23.23	23.16	23.21
10	50	0		23.28	23.20	23.27
10	1	0	16-QAM	23.41	23.43	23.41
10	1	25		23.36	23.49	23.39
10	1	49		23.44	23.35	23.37
10	25	0		22.21	22.21	22.18
10	25	12		22.19	22.21	22.17
10	25	25		22.20	22.17	22.23
10	50	0		22.23	22.20	22.23
5	1	0	QPSK	24.18	24.10	24.14
5	1	12		24.20	24.13	24.18
5	1	24		24.08	24.01	24.11
5	12	0		23.31	23.24	23.27
5	12	7		23.29	23.24	23.28
5	12	13		23.28	23.24	23.28
5	25	0		23.25	23.16	23.24
5	1	0	16-QAM	23.40	23.45	23.35
5	1	12		23.43	23.48	23.39
5	1	24		23.30	23.35	23.32
5	12	0		22.28	22.26	22.23
5	12	7		22.27	22.27	22.25
5	12	13		22.24	22.26	22.25
5	25	0		22.20	22.18	22.19



LTE Band 5 Maximum Average Power [dBm]						
BW [MHz]	RB Size	RB Offset	Mod	Lowest	Middle	Highest
3	1	0	QPSK	24.10	24.04	24.07
3	1	8		24.18	24.06	24.13
3	1	14		24.10	24.00	24.07
3	8	0		23.28	23.23	23.24
3	8	4		23.25	23.21	23.25
3	8	7		23.24	23.19	23.25
3	15	0		23.30	23.20	23.29
3	1	0	16-QAM	23.33	23.39	23.30
3	1	8		23.37	23.44	23.38
3	1	14		23.28	23.38	23.30
3	8	0		22.28	22.30	22.26
3	8	4		22.26	22.28	22.25
3	8	7		22.25	22.28	22.28
3	15	0		22.23	22.21	22.24
1.4	1	0	QPSK	24.14	24.07	24.13
1.4	1	3		24.22	24.13	24.19
1.4	1	5		24.14	24.04	24.12
1.4	3	0		24.26	24.17	24.23
1.4	3	1		24.21	24.11	24.19
1.4	3	3		24.21	24.11	24.19
1.4	6	0		23.26	23.21	23.24
1.4	1	0	16-QAM	23.38	23.44	23.36
1.4	1	3		23.47	23.49	23.44
1.4	1	5		23.39	23.40	23.34
1.4	3	0		23.24	23.27	23.24
1.4	3	1		23.20	23.23	23.19
1.4	3	3		23.19	23.22	23.18
1.4	6	0		22.29	22.32	22.27



ERP

LTE Band 5 (G _T - L _C = -0.63 dB) QPSK									
Bandwidth	1.4M			3M			5M		
Channel	20407	20525	20643	20415	20525	20635	20425	20525	20625
	(Low)	(Mid)	(High)	(Low)	(Mid)	(High)	(Low)	(Mid)	(High)
Frequency (MHz)	824.7	836.5	848.3	825.5	836.5	847.5	826.5	836.5	846.5
Conducted Power (dBm)	24.26	24.17	24.23	24.18	24.06	24.13	24.20	24.13	24.18
Conducted Power (Watts)	0.2667	0.2612	0.2649	0.2618	0.2547	0.2588	0.2630	0.2588	0.2618
ERP(dBm)	21.48	21.39	21.45	21.40	21.28	21.35	21.42	21.35	21.40
ERP(Watts)	0.1406	0.1377	0.1396	0.1380	0.1343	0.1365	0.1387	0.1365	0.1380

LTE Band 5 (G _T - L _C = -0.63 dB) QPSK			
Bandwidth	10M		
Channel	20450	20525	20600
	(Low)	(Mid)	(High)
Frequency (MHz)	829	836.5	844
Conducted Power (dBm)	24.18	24.13	24.17
Conducted Power (Watts)	0.2618	0.2588	0.2612
ERP(dBm)	21.40	21.35	21.39
ERP(Watts)	0.1380	0.1365	0.1377



LTE Band 5 (G _T - L _C = -0.63 dB) 16QAM									
Bandwidth	1.4M			3M			5M		
Channel	20407	20525	20643	20415	20525	20635	20425	20525	20625
	(Low)	(Mid)	(High)	(Low)	(Mid)	(High)	(Low)	(Mid)	(High)
Frequency (MHz)	824.7	836.5	848.3	825.5	836.5	847.5	826.5	836.5	846.5
Conducted Power (dBm)	23.47	23.49	23.44	23.37	23.44	23.38	23.43	23.48	23.39
Conducted Power (Watts)	0.2223	0.2234	0.2208	0.2173	0.2208	0.2178	0.2203	0.2228	0.2183
ERP(dBm)	20.69	20.71	20.66	20.59	20.66	20.60	20.65	20.70	20.61
ERP(Watts)	0.1172	0.1178	0.1164	0.1146	0.1164	0.1148	0.1161	0.1175	0.1151

LTE Band 5 (G _T - L _C = -0.63 dB) 16QAM			
Bandwidth	10M		
Channel	20450	20525	20600
	(Low)	(Mid)	(High)
Frequency (MHz)	829	836.5	844
Conducted Power (dBm)	23.36	23.49	23.39
Conducted Power (Watts)	0.2168	0.2234	0.2183
ERP(dBm)	20.58	20.71	20.61
ERP(Watts)	0.1143	0.1178	0.1151



Peak-to-Average Ratio

Mode	LTE Band 5 / 10MHz				
Mod.	QPSK		16QAM		Limit: 13dB
RB Size	1RB	Full RB	1RB	Full RB	Result
Lowest CH	4.38	4.93	4.9	5.86	PASS
Middle CH	4.17	5.54	5.16	6.49	
Highest CH	4.32	4.84	4.81	5.71	



LTE Band 5 / 10MHz / QPSK

Lowest Channel / 1RB

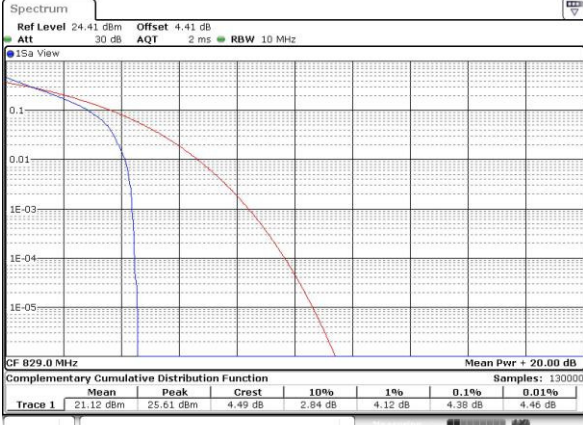

Date: 19 JAN 2017 20:23:15

Lowest Channel / Full RB

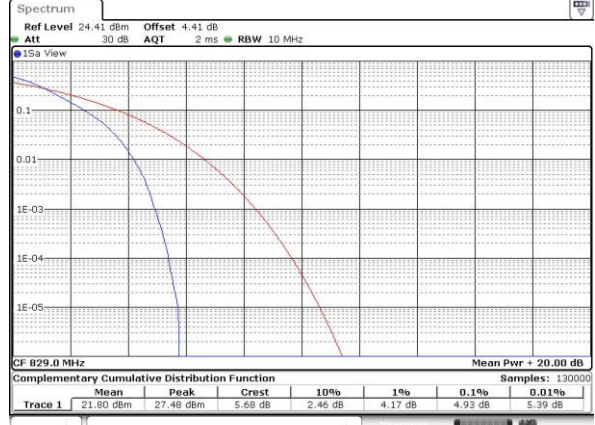

Date: 19 JAN 2017 20:23:27

Middle Channel / 1RB

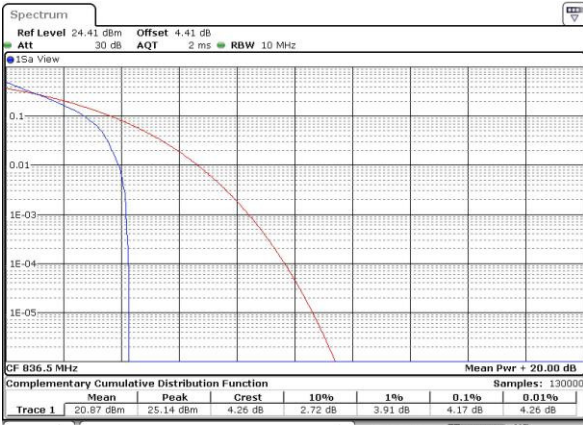

Date: 19 JAN 2017 20:23:38

Middle Channel / Full RB

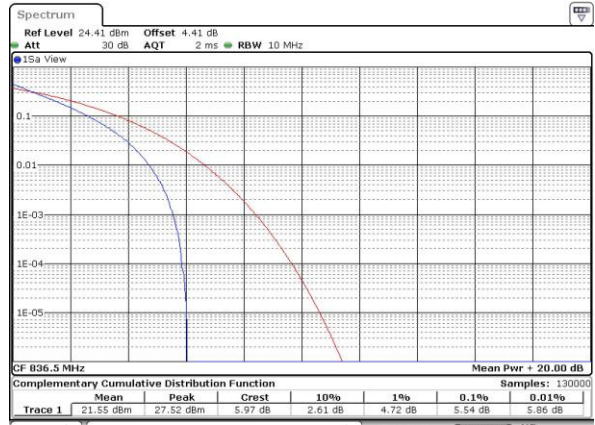

Date: 19 JAN 2017 20:23:51

Highest Channel / 1RB

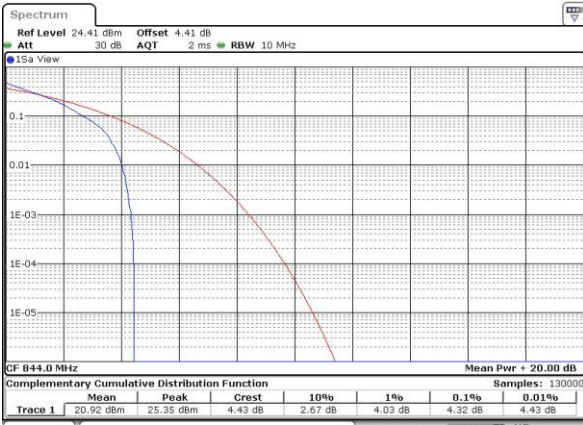

Date: 19 JAN 2017 20:24:03

Highest Channel / Full RB

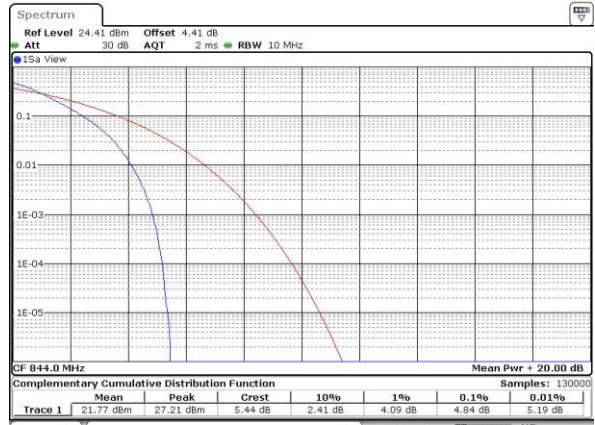

Date: 19 JAN 2017 20:24:16



LTE Band 5 / 10MHz / 16QAM

Lowest Channel / 1RB

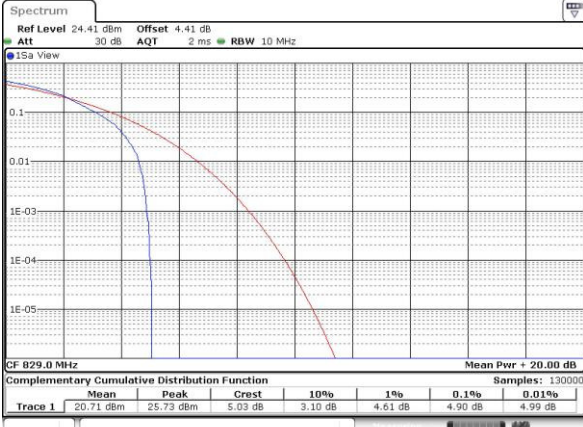

Date: 19 JAN 2017 20:21:40

Lowest Channel / Full RB

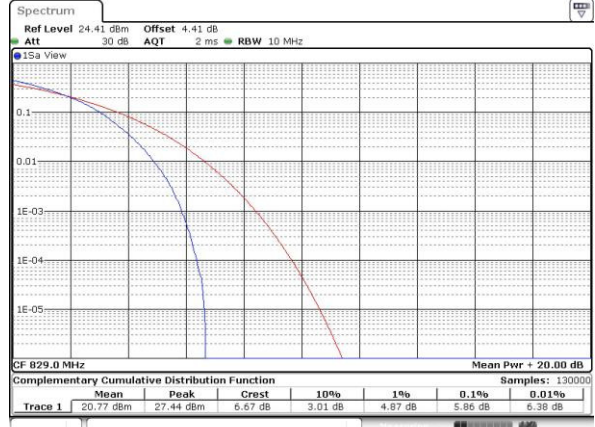

Date: 19 JAN 2017 20:21:54

Middle Channel / 1RB

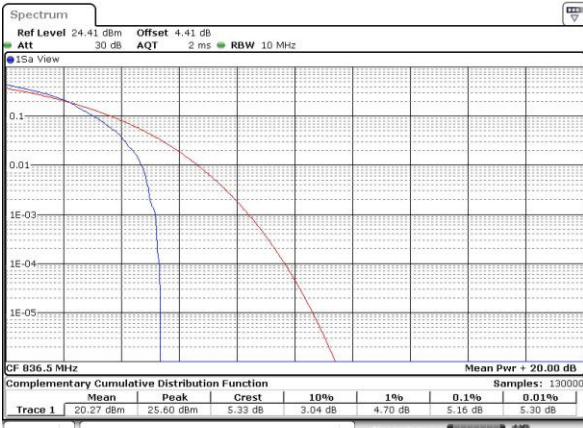

Date: 19 JAN 2017 20:22:09

Middle Channel / Full RB



Date: 19 JAN 2017 20:22:25

Highest Channel / 1RB

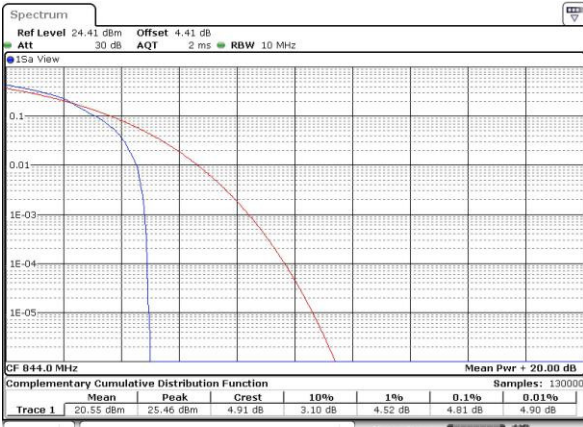

Date: 19 JAN 2017 20:22:40

Highest Channel / Full RB

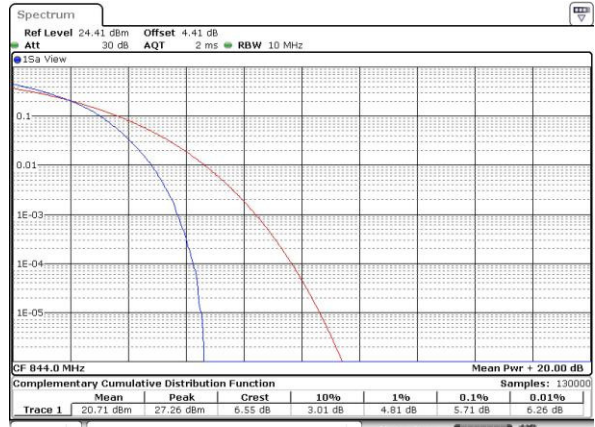

Date: 19 JAN 2017 20:23:01



26dB Bandwidth

Mode	LTE Band 5 : 26dB BW(MHz)											
	1.4MHz		3MHz		5MHz		10MHz		15MHz		20MHz	
BW												
Mod.	QPSK	16QAM	QPSK	16QAM	QPSK	16QAM	QPSK	16QAM	QPSK	16QAM	QPSK	16QAM
Lowest CH	1.242	1.259	2.991	2.967	4.905	4.925	9.69	9.87	-	-	-	-
Middle CH	1.27	1.27	2.961	2.949	4.915	5.055	9.99	10.05	-	-	-	-
Highest CH	1.253	1.27	2.979	2.973	5.055	4.855	9.85	9.67	-	-	-	-



LTE Band 5

Lowest Channel / 1.4MHz / QPSK

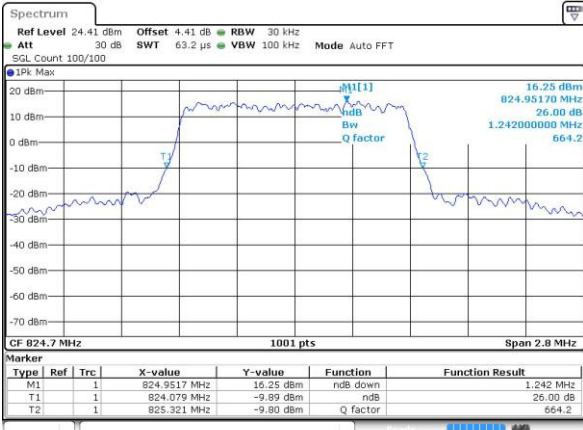

Date: 19 JAN 2017 18:57:20

Lowest Channel / 1.4MHz / 16QAM

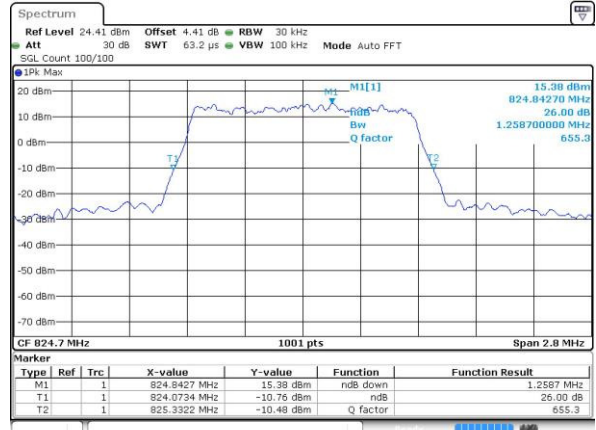

Date: 19 JAN 2017 18:57:09

Middle Channel / 1.4MHz / QPSK

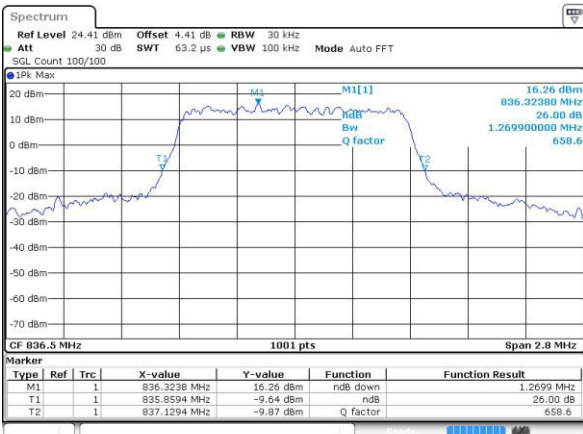

Date: 19 JAN 2017 19:06:26

Middle Channel / 1.4MHz / 16QAM

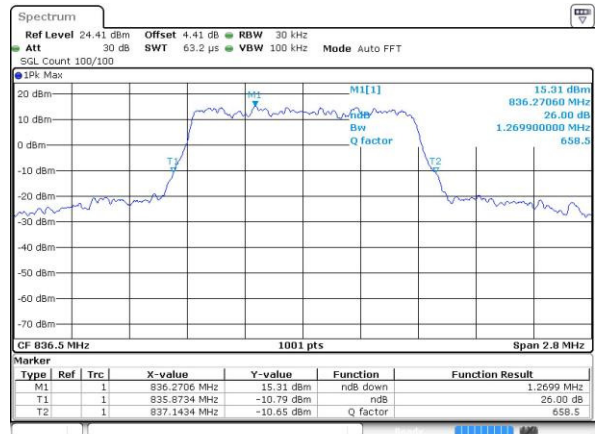

Date: 19 JAN 2017 19:06:37

Highest Channel / 1.4MHz / QPSK

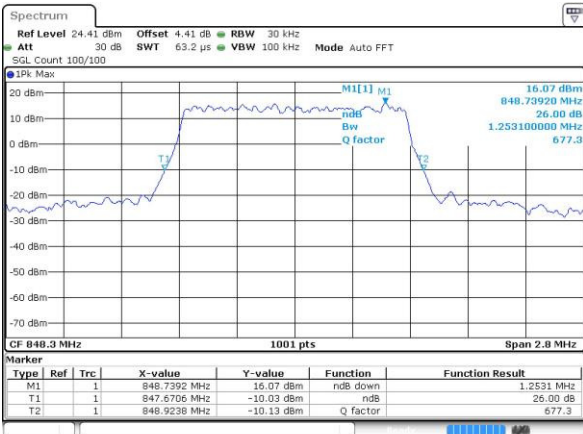

Date: 19 JAN 2017 19:09:04

Highest Channel / 1.4MHz / 16QAM

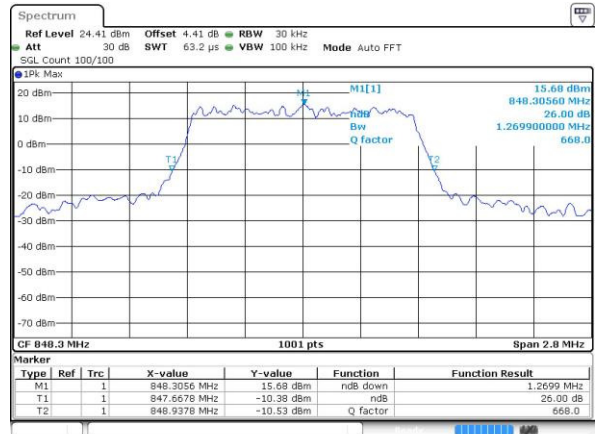

Date: 19 JAN 2017 19:09:15



LTE Band 5

Lowest Channel / 3MHz / QPSK

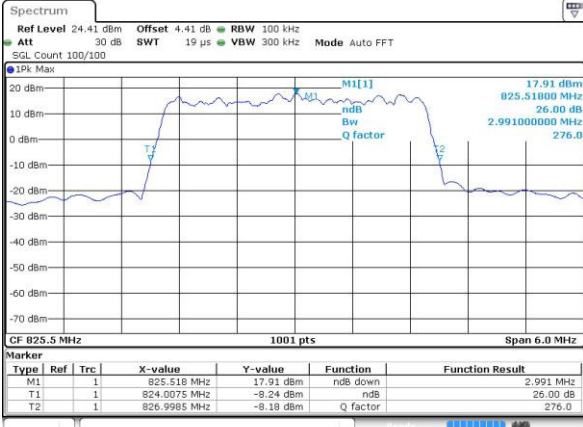

Date: 19 JAN 2017 19:18:20

Lowest Channel / 3MHz / 16QAM

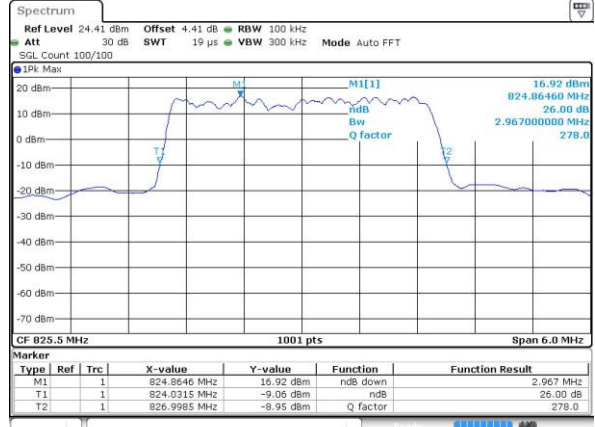

Date: 19 JAN 2017 19:18:31

Middle Channel / 3MHz / QPSK

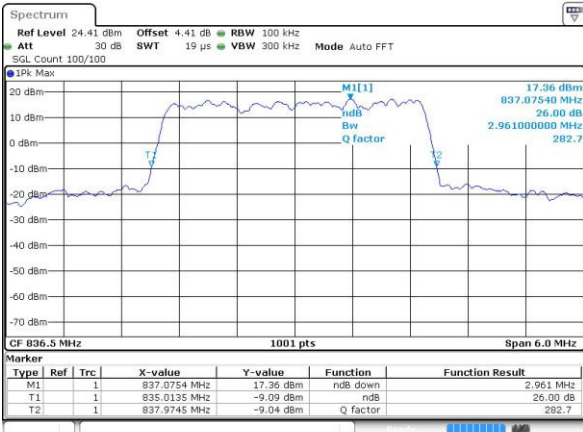

Date: 19 JAN 2017 19:27:36

Middle Channel / 3MHz / 16QAM

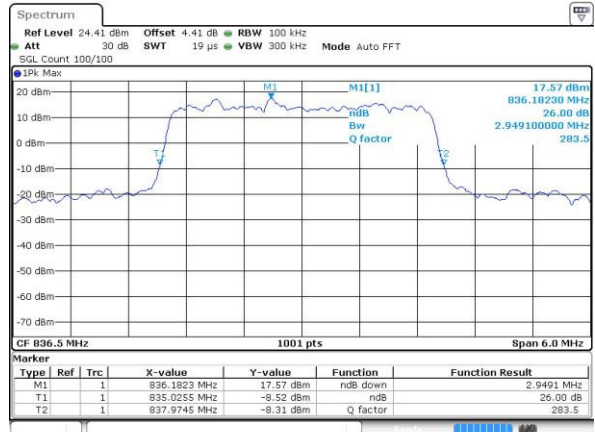

Date: 19 JAN 2017 19:27:47

Highest Channel / 3MHz / QPSK

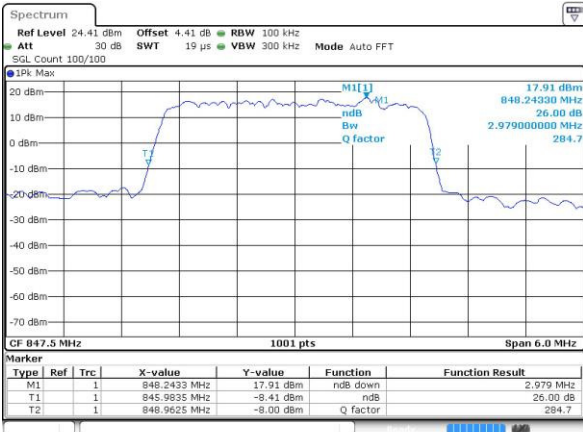

Date: 19 JAN 2017 19:30:15

Highest Channel / 3MHz / 16QAM

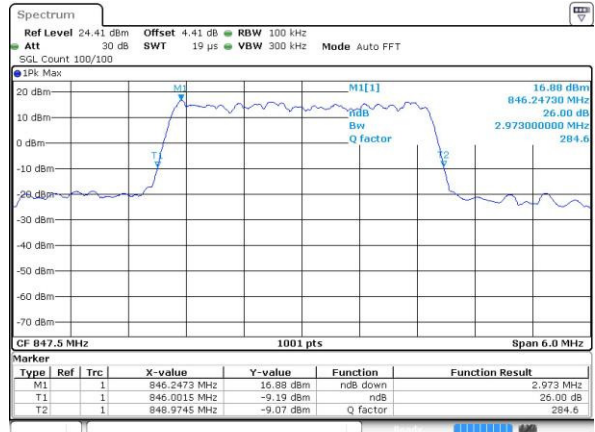

Date: 19 JAN 2017 19:30:26



LTE Band 5

Lowest Channel / 5MHz / QPSK

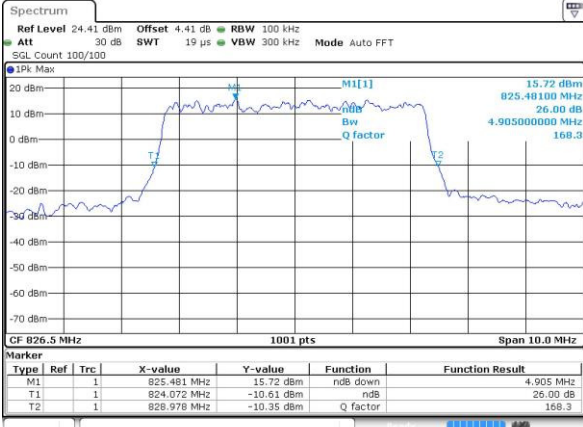

Date: 19 JAN 2017 19:39:30

Lowest Channel / 5MHz / 16QAM

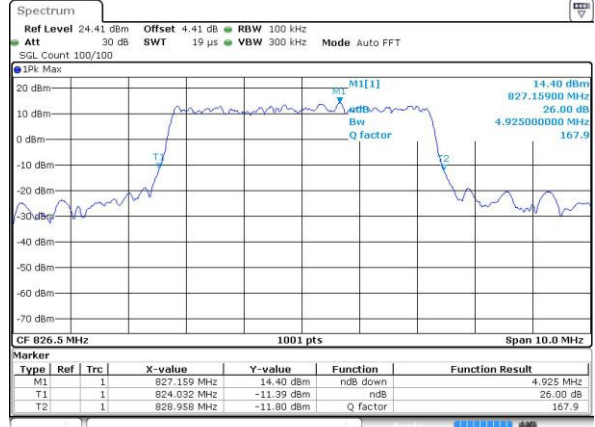

Date: 19 JAN 2017 19:39:41

Middle Channel / 5MHz / QPSK

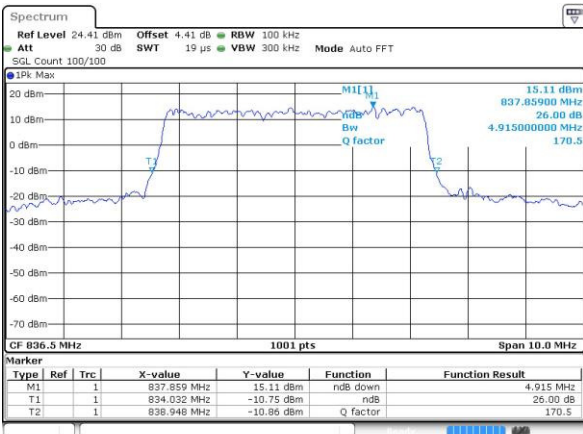

Date: 19 JAN 2017 19:48:45

Middle Channel / 5MHz / 16QAM

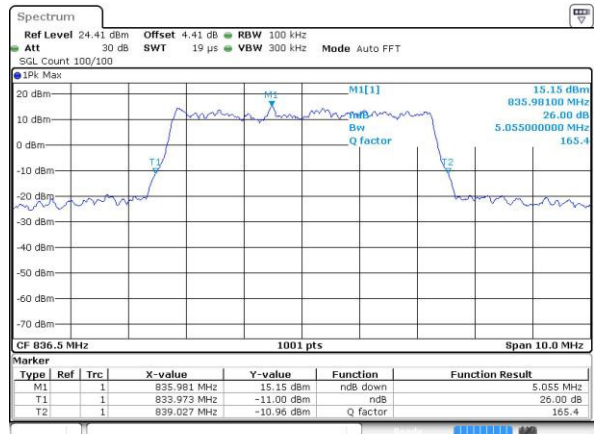

Date: 19 JAN 2017 19:48:56

Highest Channel / 5MHz / QPSK

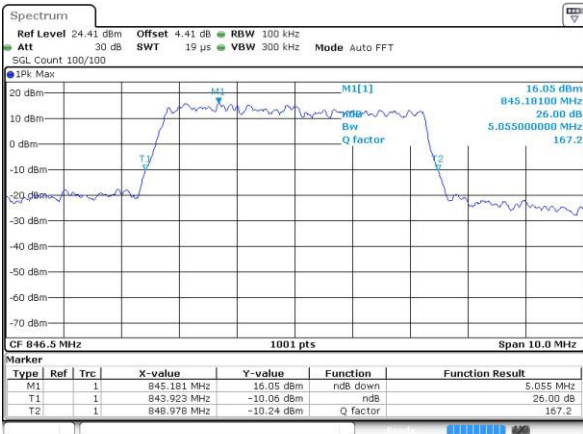

Date: 19 JAN 2017 19:51:24

Highest Channel / 5MHz / 16QAM

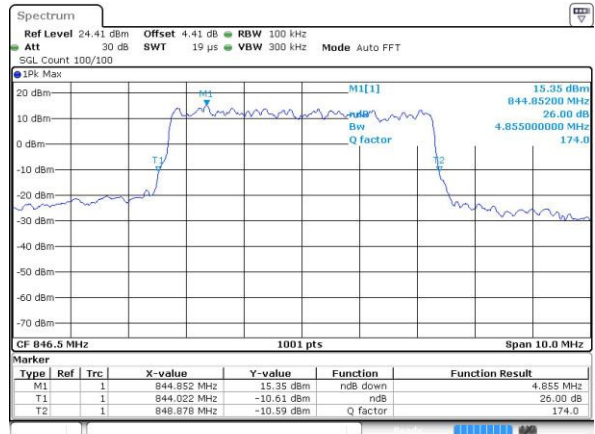

Date: 19 JAN 2017 19:51:35



LTE Band 5

Lowest Channel / 10MHz / QPSK

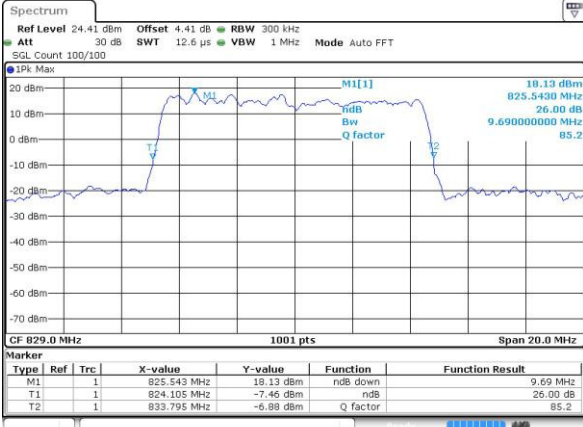

Date: 19 JAN 2017 20:00:40

Lowest Channel / 10MHz / 16QAM

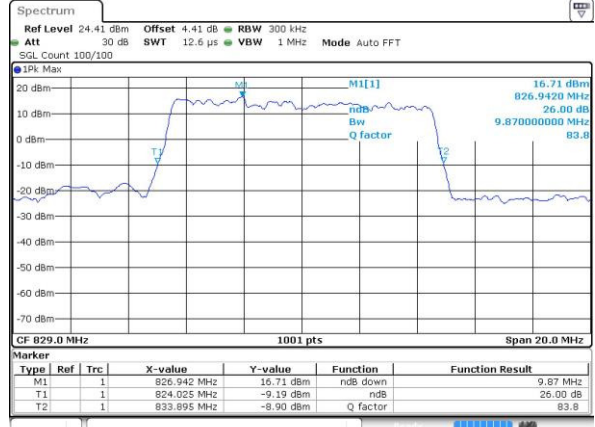

Date: 19 JAN 2017 20:00:51

Middle Channel / 10MHz / QPSK

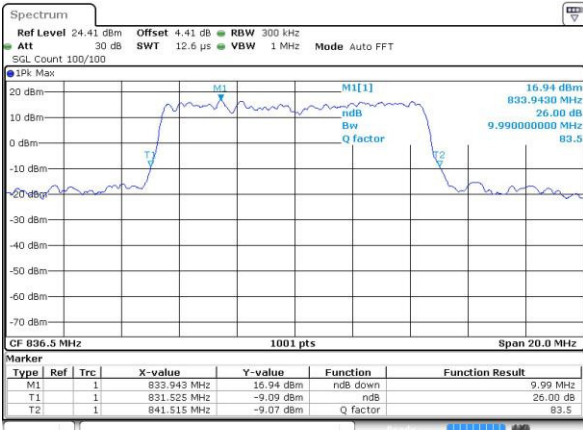

Date: 19 JAN 2017 20:09:56

Middle Channel / 10MHz / 16QAM

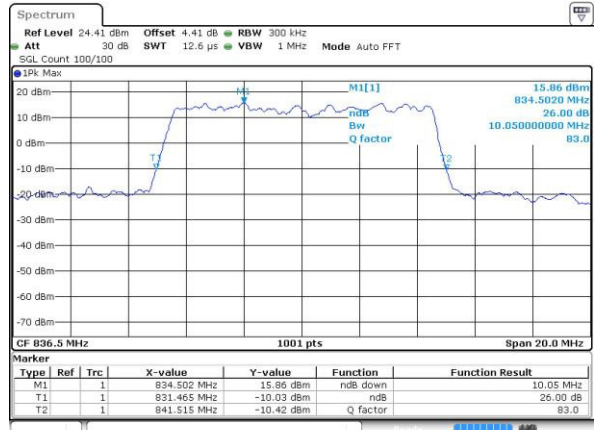

Date: 19 JAN 2017 20:10:07

Highest Channel / 10MHz / QPSK

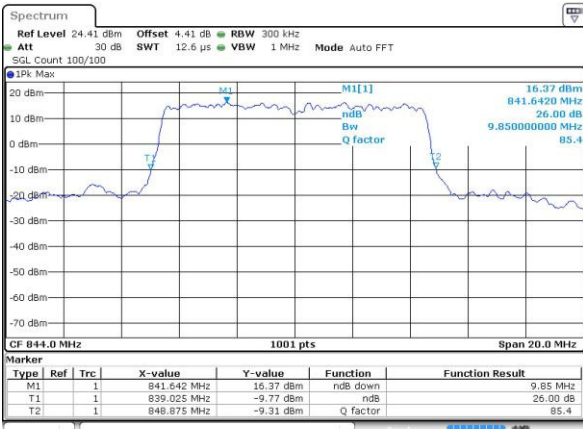

Date: 19 JAN 2017 20:12:34

Highest Channel / 10MHz / 16QAM

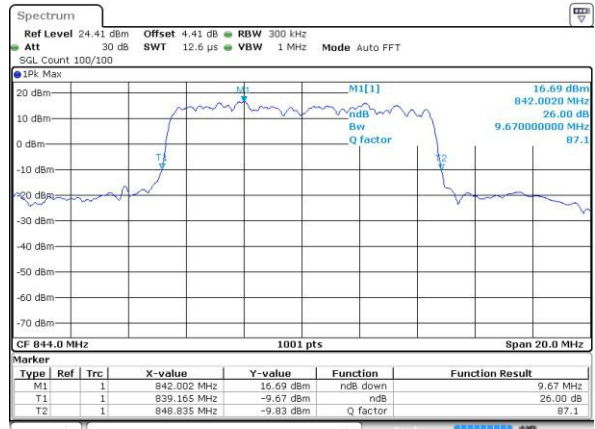

Date: 19 JAN 2017 20:12:45



Occupied Bandwidth

Mode	LTE Band 5 : 99%OBW(MHz)											
	1.4MHz		3MHz		5MHz		10MHz		15MHz		20MHz	
BW												
Mod.	QPSK	16QAM	QPSK	16QAM	QPSK	16QAM	QPSK	16QAM	QPSK	16QAM	QPSK	16QAM
Lowest CH	1.09	1.1	2.72	2.72	4.47	4.51	8.97	9.05	-	-	-	-
Middle CH	1.09	1.09	2.73	2.7	4.5	4.51	9.11	9.05	-	-	-	-
Highest CH	1.1	1.1	2.7	2.73	4.52	4.5	9.05	9.07	-	-	-	-



LTE Band 5

Lowest Channel / 1.4MHz / QPSK

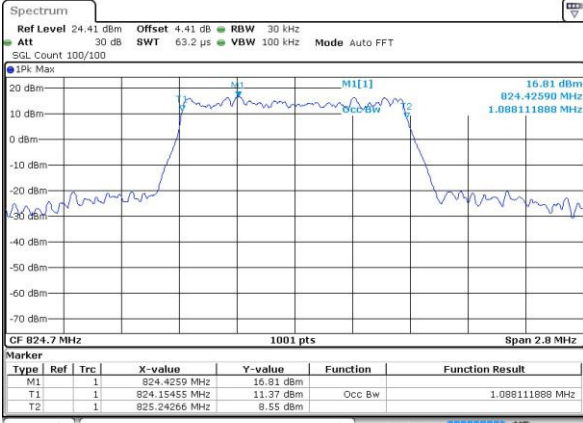

Date: 19 JAN 2017 18:56:46

Lowest Channel / 1.4MHz / 16QAM

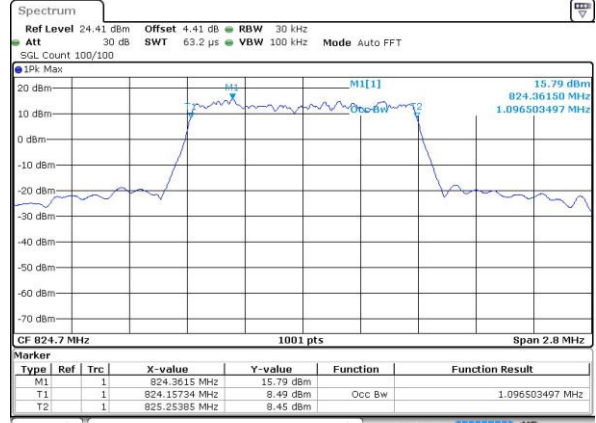

Date: 19 JAN 2017 18:56:58

Middle Channel / 1.4MHz / QPSK

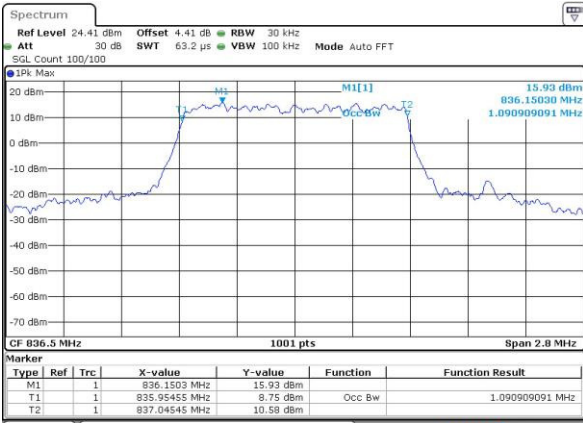

Date: 19 JAN 2017 19:06:03

Middle Channel / 1.4MHz / 16QAM

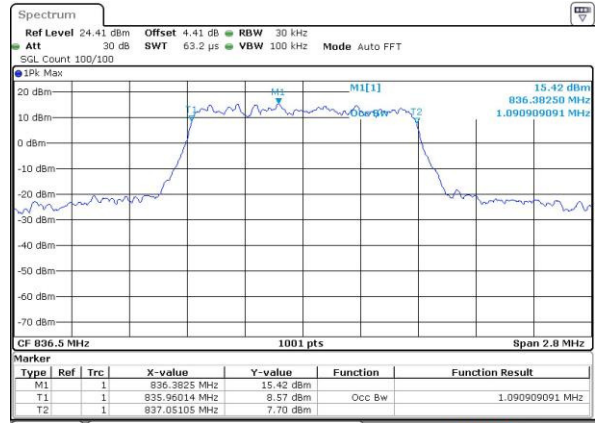

Date: 19 JAN 2017 19:06:15

Highest Channel / 1.4MHz / QPSK

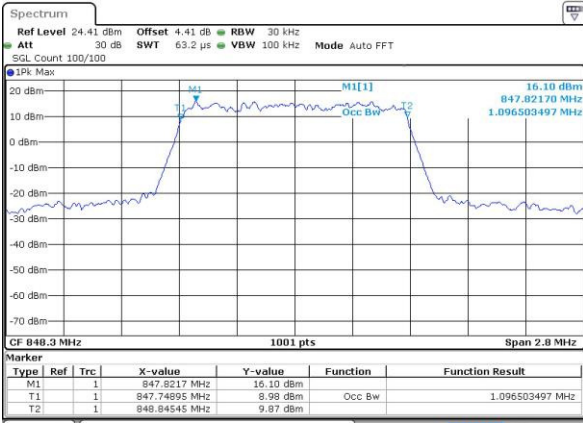

Date: 19 JAN 2017 19:08:41

Highest Channel / 1.4MHz / 16QAM

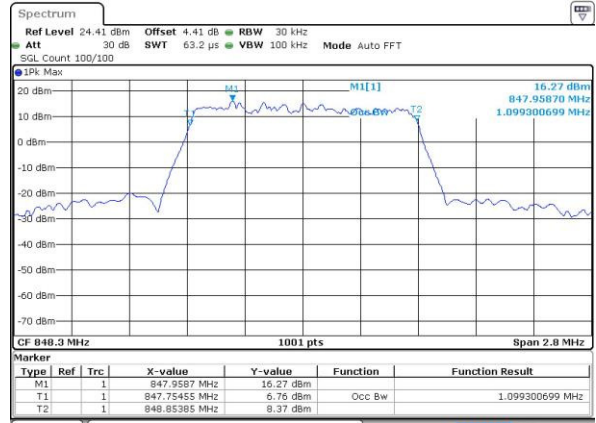

Date: 19 JAN 2017 19:08:53



LTE Band 5

Lowest Channel / 3MHz / QPSK

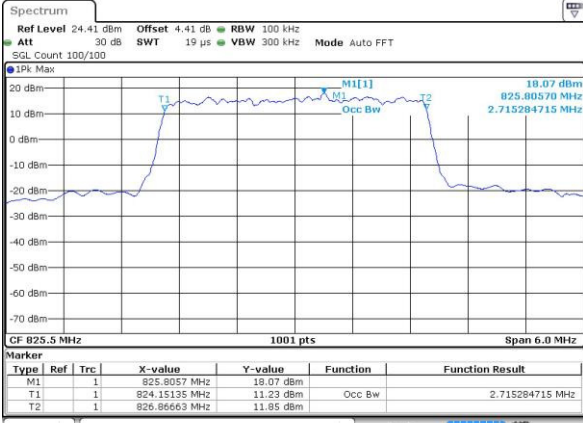

Date: 19 JAN 2017 19:17:58

Lowest Channel / 3MHz / 16QAM

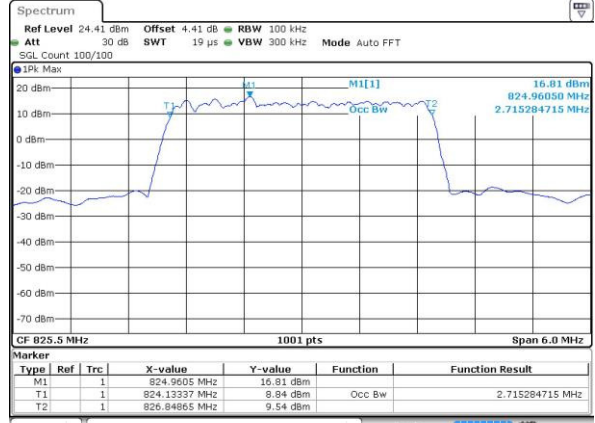

Date: 19 JAN 2017 19:18:09

Middle Channel / 3MHz / QPSK

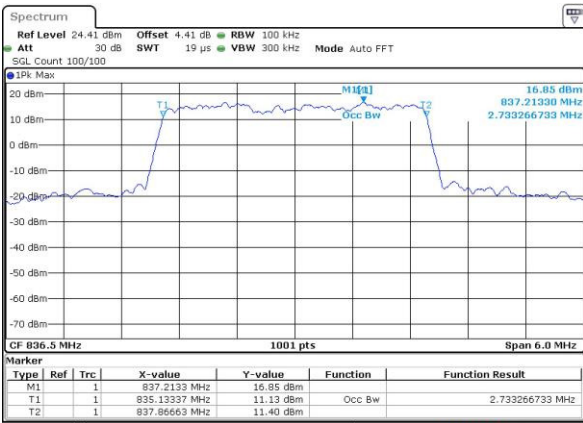

Date: 19 JAN 2017 19:27:14

Middle Channel / 3MHz / 16QAM

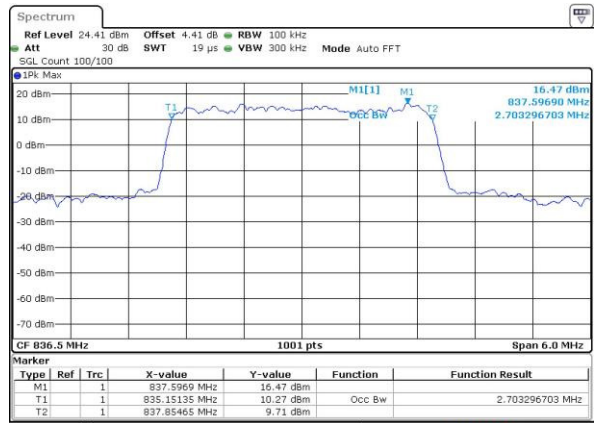

Date: 19 JAN 2017 19:27:25

Highest Channel / 3MHz / QPSK

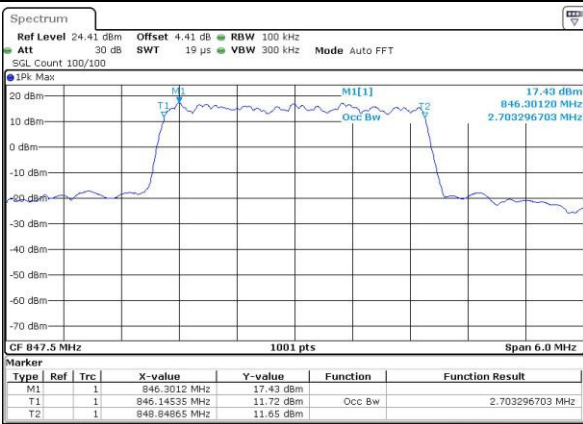

Date: 19 JAN 2017 19:29:52

Highest Channel / 3MHz / 16QAM

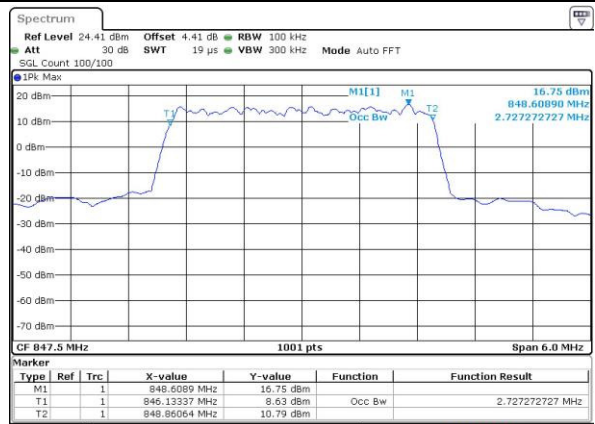

Date: 19 JAN 2017 19:30:03



LTE Band 5

Lowest Channel / 5MHz / QPSK

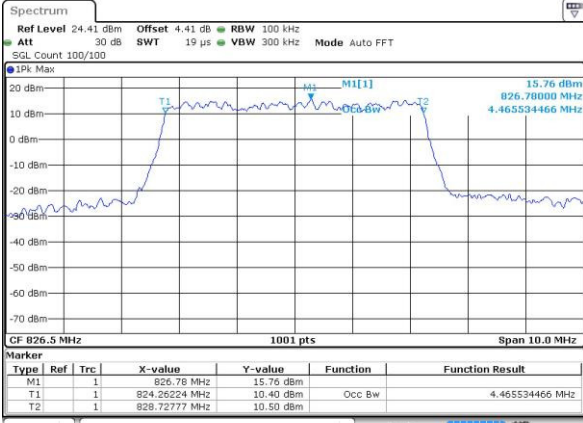

Date: 19 JAN 2017 19:39:07

Lowest Channel / 5MHz / 16QAM

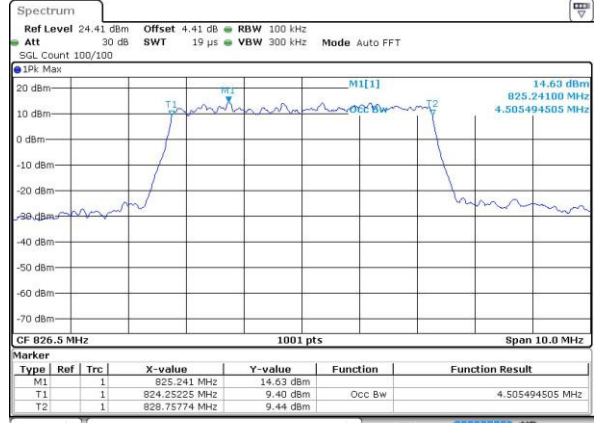

Date: 19 JAN 2017 19:39:19

Middle Channel / 5MHz / QPSK

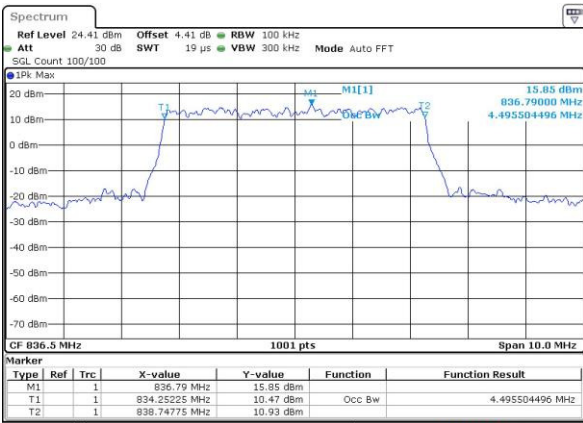

Date: 19 JAN 2017 19:48:22

Middle Channel / 5MHz / 16QAM

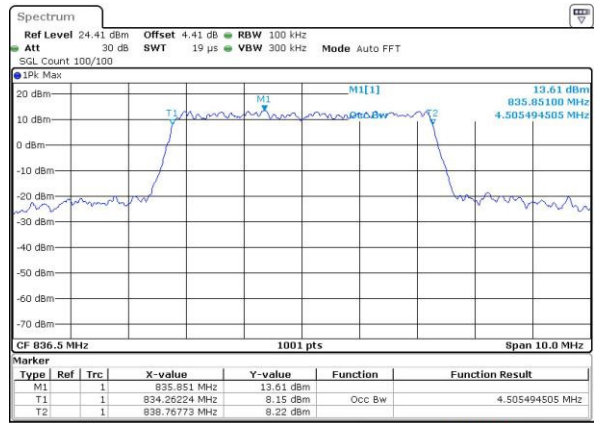

Date: 19 JAN 2017 19:48:34

Highest Channel / 5MHz / QPSK

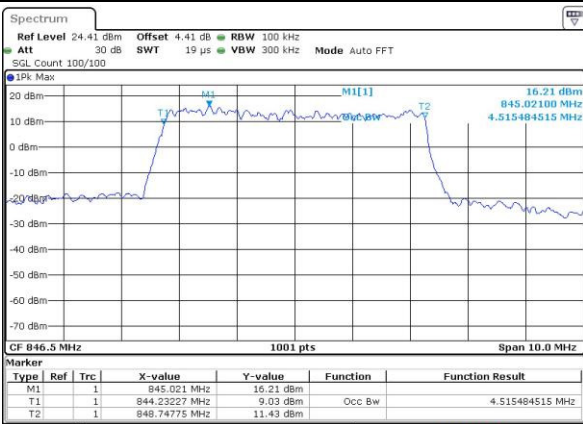

Date: 19 JAN 2017 19:51:01

Highest Channel / 5MHz / 16QAM

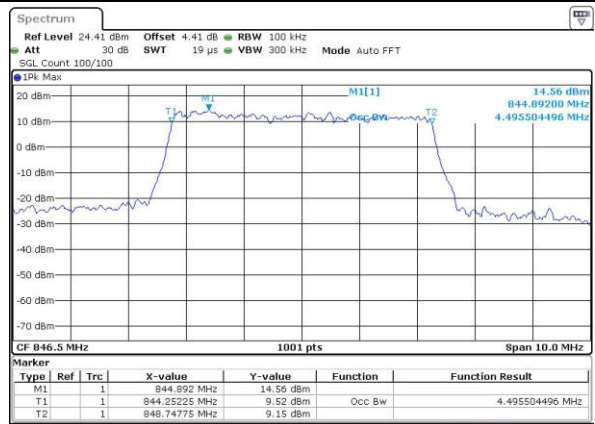

Date: 19 JAN 2017 19:51:13



LTE Band 5

Lowest Channel / 10MHz / QPSK

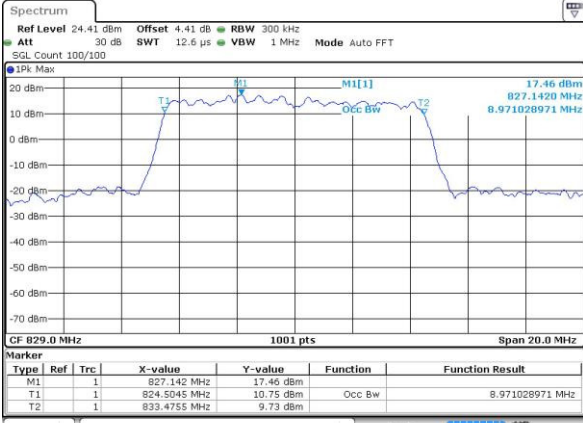

Date: 19 JAN 2017 20:00:18

Lowest Channel / 10MHz / 16QAM

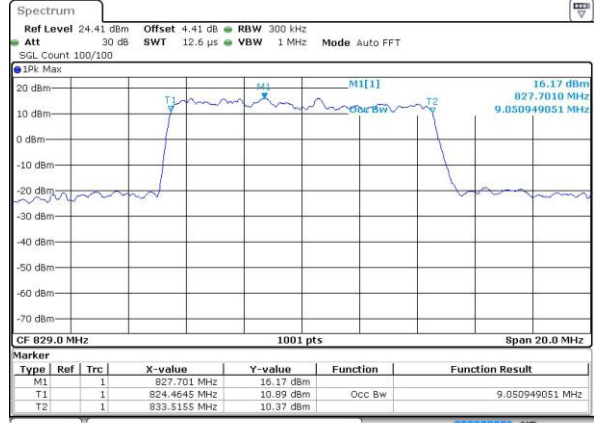

Date: 19 JAN 2017 20:00:29

Middle Channel / 10MHz / QPSK

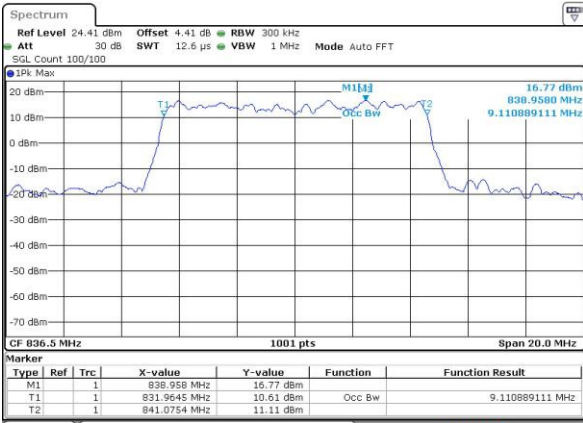

Date: 19 JAN 2017 20:09:33

Middle Channel / 10MHz / 16QAM

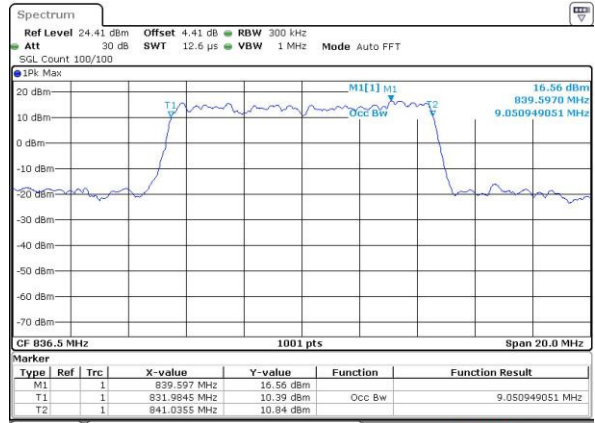

Date: 19 JAN 2017 20:09:44

Highest Channel / 10MHz / QPSK

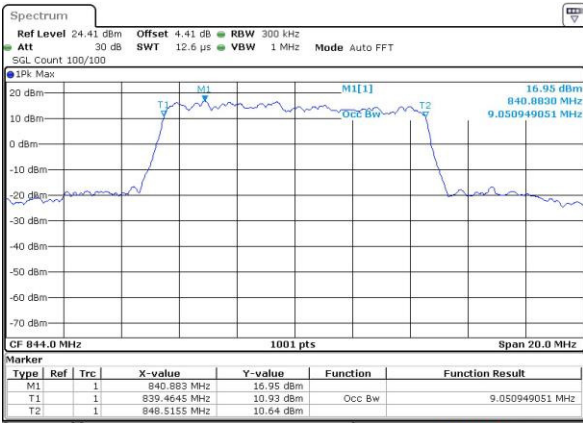

Date: 19 JAN 2017 20:12:11

Highest Channel / 10MHz / 16QAM

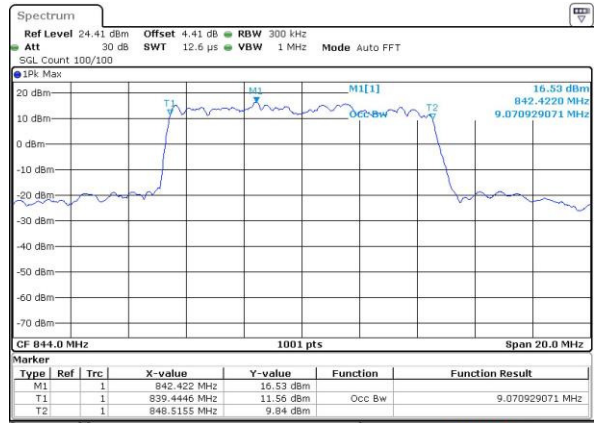

Date: 19 JAN 2017 20:12:22



Conducted Band Edge

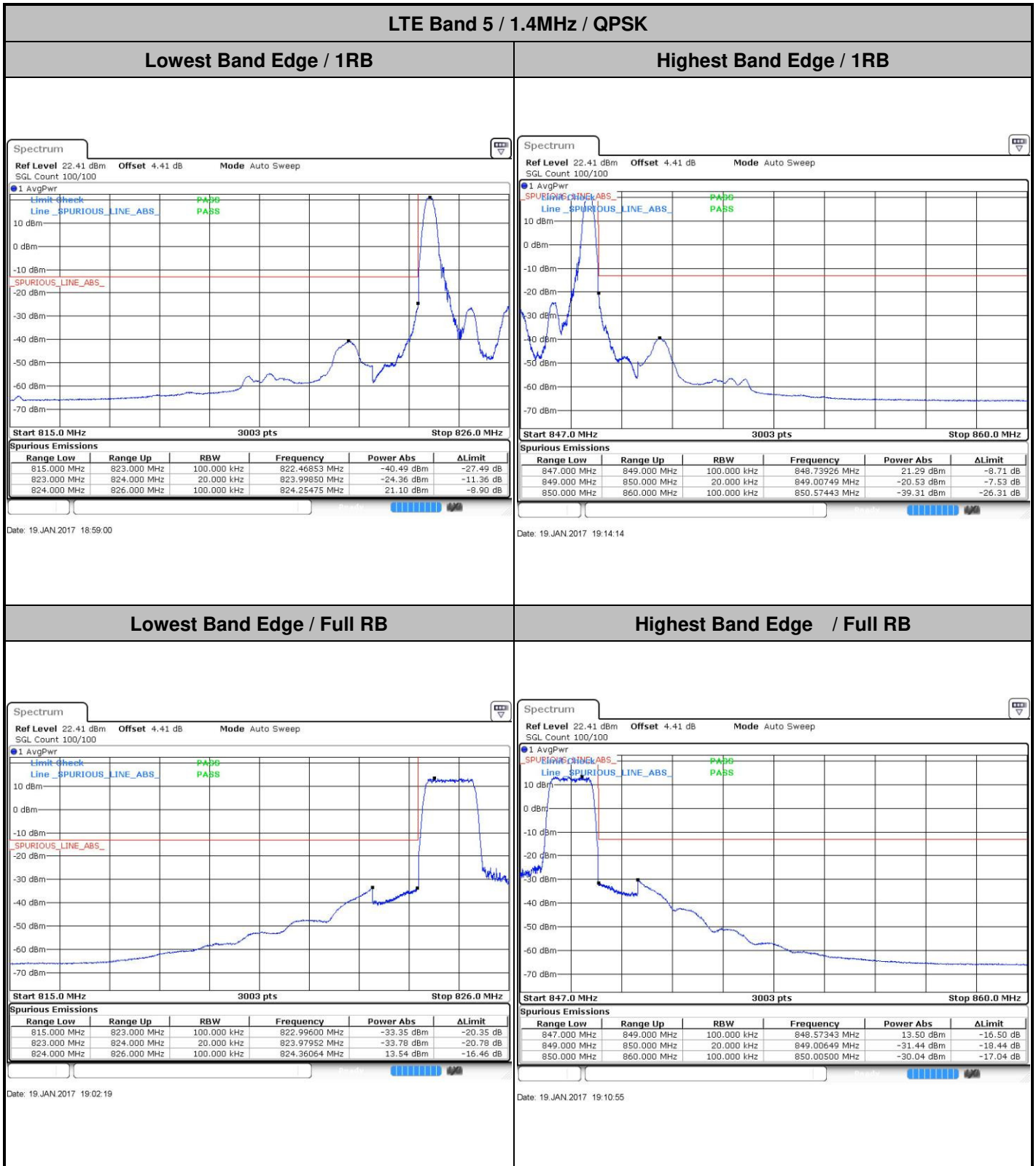



LTE Band 5 / 1.4MHz / 16QAM

Lowest Band Edge / 1 RB



Date: 19 JAN 2017 19:00:40

Highest Band Edge / 1 RB



Date: 19 JAN 2017 19:15:53

Lowest Band Edge / Full RB

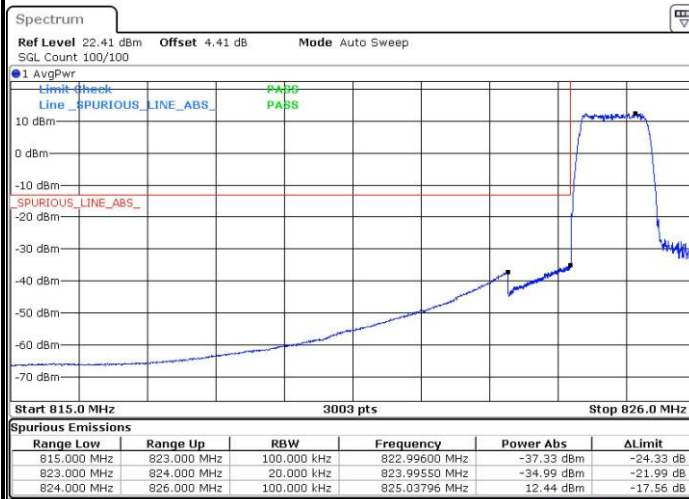

Date: 19 JAN 2017 19:03:58

Highest Band Edge / Full RB



Date: 19 JAN 2017 19:12:34



LTE Band 5 / 3MHz / QPSK

Lowest Band Edge / 1RB

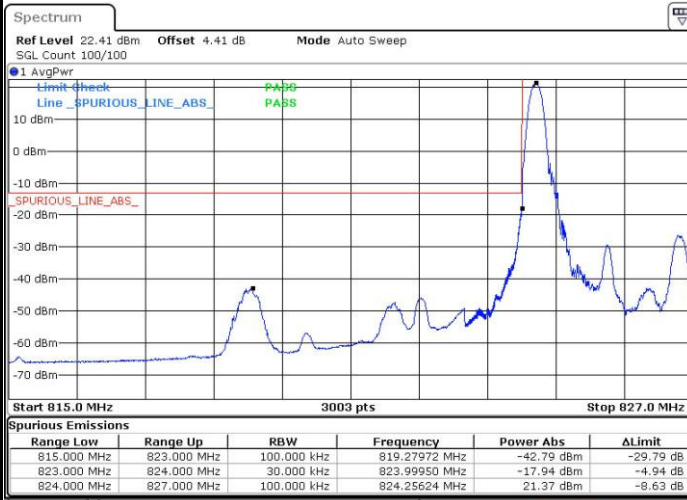

Date: 19 JAN 2017 19:20:11

Highest Band Edge / 1 RB

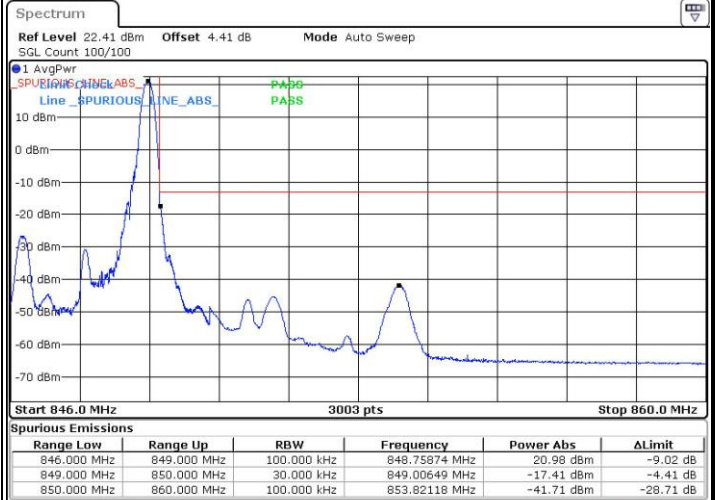

Date: 19 JAN 2017 19:32:05

Lowest Band Edge / Full RB

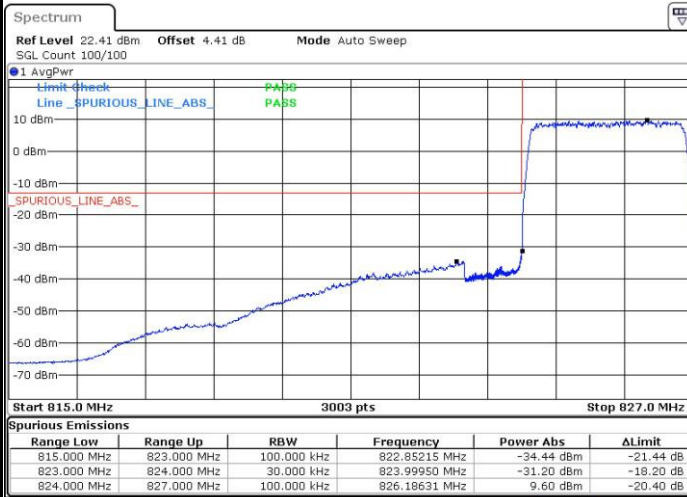

Date: 19 JAN 2017 19:23:29

Highest Band Edge / Full RB



Date: 19 JAN 2017 19:35:24



LTE Band 5 / 3MHz / 16QAM

Lowest Band Edge / 1 RB

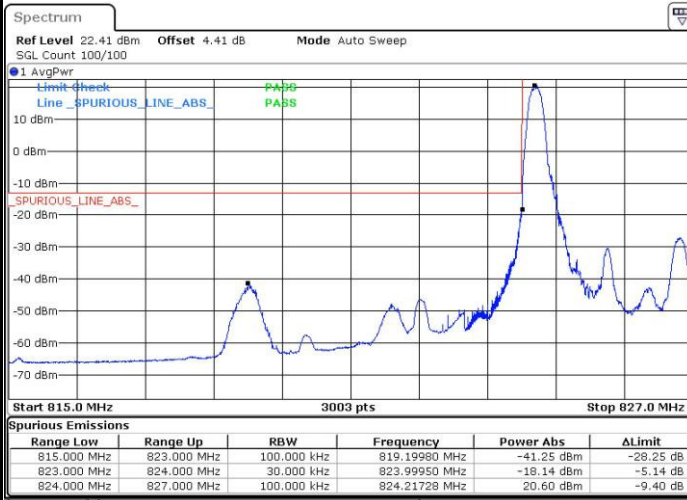

Date: 19 JAN 2017 19:21:50

Highest Band Edge / 1 RB



Date: 19 JAN 2017 19:33:44

Lowest Band Edge / Full RB



Date: 19 JAN 2017 19:25:08

Highest Band Edge / Full RB



Date: 19 JAN 2017 19:37:03