

VAXIS.ATOM 500 SDI

Wireless Video System

Instructions

Dear users:

Thank you very much for choosing ATOM 500 wireless video transmission equipment. This product adopts h.265 image coding and decoding technology and 5g wireless transmission technology. Realize low delay and high quality video transmission. We sincerely hope that you can enjoy the long-term convenience of using the product and wish you the best experience from the product.

All the information contained in this manual has been strictly verified to be correct at the time of publication. However, due to the continuous upgrading and improvement of the product, we hope that your equipment and use may be different from the description in this manual. For this, we hope you will take the actual product as the standard, and welcome you to call our service phone for

consultation.

■Main features:

- Stable transmission distance 100m
- Highest resolution 1080p 60, 60-100ms delay
- Built in antenna , easy to install and use
- Support mobile APP monitoring and password protection
- Support HDMI loop out
- up to 9 free frequency switching options
- OLED screen display the current channel,power status,signal strength
- Support USB type C and Sony F97 battery power supply, meet the needs of various environments
- Any input and output ports with ± 4 kV ESD protection level (HBM, contact discharge)

Application scenario

| | |
|----------------|--|
| Film shooting | Educational recording and broadcasting |
| Live broadcast | wedding ceremony |
| Sports events | Enterprise activity |

Packing list

Transmitter *1

Receiver *1

user's manual*1

Expanding accessories *1

Cold boot platform*1

Type-C power cord*1

Hexagon wrench*1

Introduction

- Thank you for choosing our long-range wireless HDMI products. Before you install the product, please read the user manual carefully and follow the manual of the user manual to avoid product damaged or other safety accidents.
- Due to product version upgrade or other reasons, the contents of this manual will be updated from time to time. Unless otherwise agreed, this manual is used only as a guide, and all statements, information and recommendations in this manual do not constitute any guarantee either express or implied.

■Name of the product parts

Transmitter:

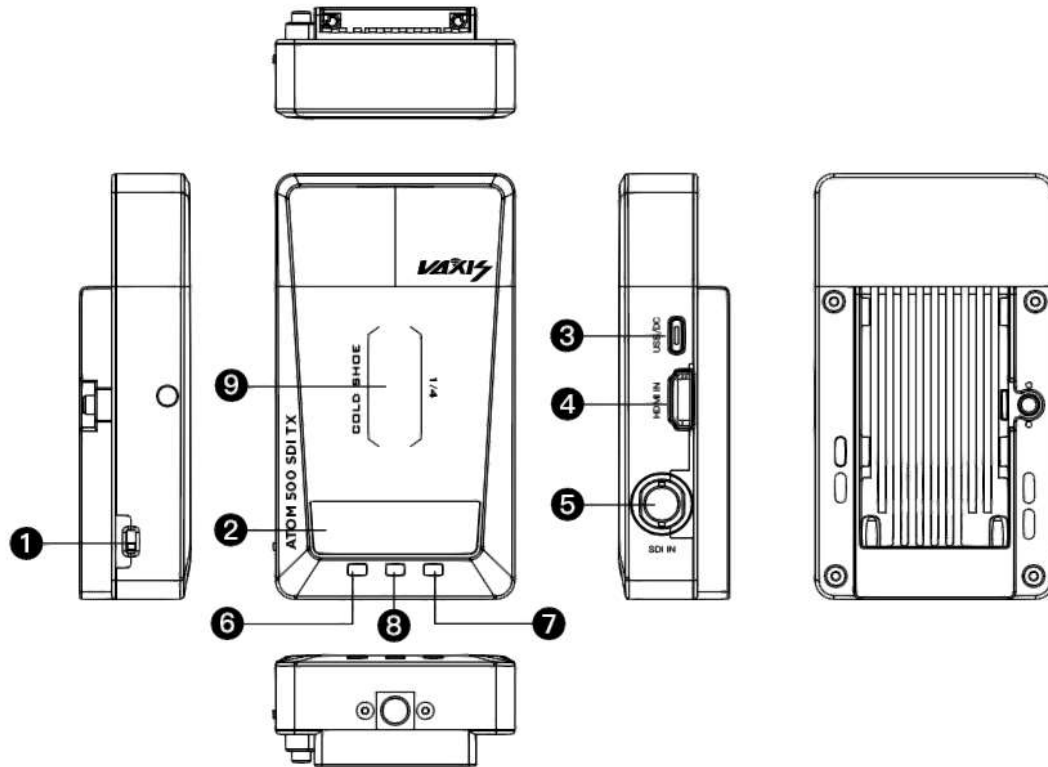

- ① Power switch
- ② Screen display
- ③ HDMI Output
- ④ HDMI Input
- ⑤ Type-C DC Input
- ⑥ Direction button1
- ⑦ Direction button2
- ⑧ Menu button
- ⑨ Installation of extension accessories

Receiver:

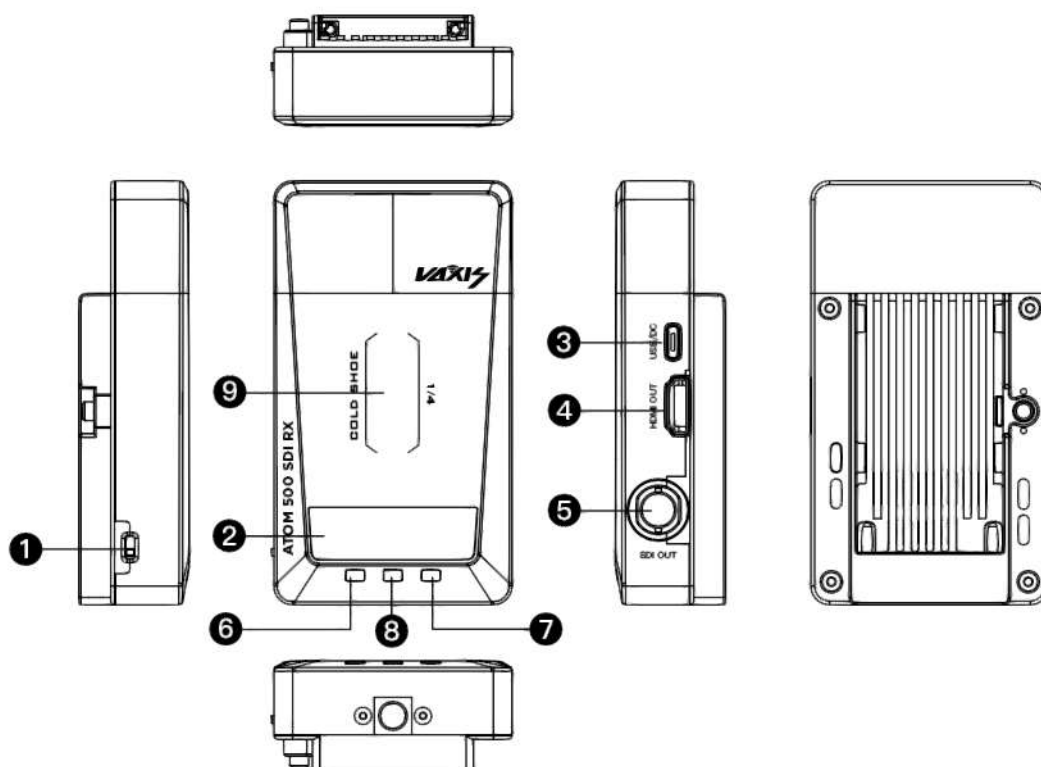

- ① Power switch
- ② Screen display
- ③ HDMI Output
- ④ HDMI Output
- ⑤ Type-C DC Input
- ⑥ Direction button1
- ⑦ Direction button2
- ⑧ Menu button
- ⑨ Installation of extension accessories

■Parameters:

| | Transmitter | Receiver |
|----------------------|--|---|
| Interface | HDMI/ input(Type A Female), /SDI input, Type-C interface | HDMI Output 1(Type A Female), SDI Output, Type-C interface |
| Supply Voltage Range | 5V DC | 5V DC |
| Power consumption | <6.5W | <4.5W |
| Size | (LxWxH):105x64x28mm | (LxWxH):105x64x28mm |
| Mass | 134g | 130g |
| Input Video Format | HDMI/SDI 720p59.94/60, 1080i 50/59.94/60, 1080p23.98/24/25/29.9/30/50/59.94/60; | / |
| Output Video Format | / | HDMI/SDI 720p59.94/60, 1080i 50/59.94/60, 1080p23.98/24/25/29.9/30/50/59.94/60 |
| Signal Indicator | OLED Display | OLED Display |
| Frequency Band | WIFI 5180MHz-5240MHz WIFI 5745MHz-5825MHz | WIFI 5180MHz-5240MHz WIFI 5745MHz-5825MHz |
| Occupied Bandwidth | 20MHz | 20MHz |
| Compliance | FCC;CE. | FCC;CE. |

Operation guide

1. Frequency switching

Press the transmitter "direction key" to switch the frequency point, press the menu key to confirm the frequency point, and the receiver will automatically switch the connected frequency point synchronously. No frequency point switching function of receiver.

2. App password modification method

Press "menu" key for menu interface, switch to "PWD < current >", click "menu" to confirm, switch to "new", click "menu" to confirm, wait for about 10s. (Note: password can be modified when TX and Rx are in normal connection state)

3. Fan regulation mode

Press and hold the direction key for 3S to enter the fan adjustment selection menu, and select "FAN LOW", "FAN HIGH" "FAN AUTO" "FAN OFF". (Note: Fan off can only be turned off for 5 minutes at a time).

4. APP monitoring switch mode

Press and hold the menu key on the menu interface of the

transmitter, and switch to app < on > L, which is on by default.
Click to switch to < off > to close the app connection

5. App installation and use

- ① App name is "vaxis vision" , Download in app storeg



- ② Usage method

- a. Open app "vaxis vision" to select the connection device
- b. Long press TX menu key for 3S, switch to SSID, and input WiFi name (VX a00001) to app
- c. The TX menu is switched to PWD<CURRENT>, and the 8-digit number displayed is WiFi password. Input it to app and click Connect.

6. This device is a non-handheld device, and the distance between the device and people is greater than 20cm during work.

Common troubleshooting

1. Connection exception

- a. Please check whether TX / RX power supply is normal
- b. When RX is always displayed as link, please restart TXRX / switch to a clean frequency point

2. Display abnormal problems

- a. Please check whether the video source is connected to HDMI in correctly
- b. Please check whether the signal format can be normally displayed on the OLED screen

3. Video picture jam

- a. Please check whether the signal quality displayed by the receiver is good. If the signal is weak, please switch the frequency point or shorten the wireless connection distance
- b. If it is impossible to determine which channel has low environmental interference, please restart TX and select a cleaner channel for automatic frequency sweep

FCC Statement

This device complies with Part 15 of the FCC Rules. Operation is subject to the following two conditions: (1) this device may not cause harmful interference and (2) this device must accept any interference received, including interference that may cause undesired operation.

Any Changes or modifications not expressly approved by the party responsible for compliance could void the user's authority to operate the equipment.

Note: This equipment has been tested and found to comply with the limits for a Class B digital device, pursuant to part 15 of the FCC Rules. These limits are designed to provide reasonable protection against harmful interference in a residential installation. This equipment generates uses and can radiate radio frequency energy and, if not installed and used in accordance with the instructions, may cause harmful interference to radio communications. However, there is no guarantee that interference will not occur in a particular installation. If this equipment does cause harmful interference to radio or television reception, which can be determined by turning the equipment off and on, the user is encouraged to try to correct the interference by one or more of the following measures:

- Reorient or relocate the receiving antenna.
- Increase the separation between the equipment and receiver.
- Connect the equipment into an outlet on a circuit different from that to which the receiver is connected.
- Consult the dealer or an experienced radio/TV technician for help.

The device has been evaluated to meet general RF exposure requirement. The device can be used in portable exposure condition without restriction.

Part 15B Equipment

This equipment has been tested and found to comply with the limits for a Class B digital device, pursuant to part 15 of the FCC rules. These limits are designed to provide reasonable protection against harmful interference in a residential installation. This equipment generates, uses and can radiate radio frequency energy and, if not installed and used in accordance with the instructions, may cause harmful interference to radio communications.

However, there is no guarantee that interference will not occur in a particular installation. If this equipment does cause harmful interference to radio or television reception, which can be determined by turning the equipment off and on, the user is encouraged to try to correct the interference by one or more of the following measures:

- Reorient or relocate the receiving antenna.
- Increase the separation between the equipment and receiver.

Connect the equipment into an outlet on a circuit different from that to which the receiver is connected.

- Consult the dealer or an experienced radio/TV technician for help.

Any changes or modifications not expressly approved by the manufacturer could void the user's authority to operate the equipment

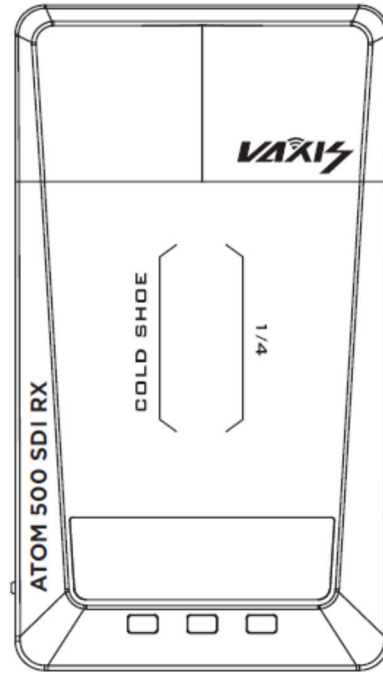
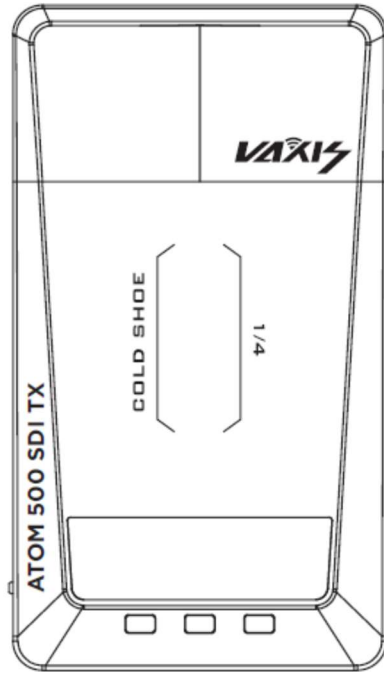

湖南光魔科技有限公司
HN Gmcine Technology Co., Ltd.
电话: +86400-014-7080



威固官方网站



微信公众号