

## System Check\_H750

Frequency: 750 MHz; Duty Cycle: 1:1; Room Ambient Temperature: 23.0°C; Liquid Temperature: 22.0°C

Medium parameters used:  $f = 750$  MHz;  $\sigma = 0.924$  S/m;  $\epsilon_r = 41.978$ ;  $\rho = 1000$  kg/m<sup>3</sup>

DASY5 Configuration:

- Area Scan Setting: Find Secondary Maximum Within: 2.0 dB and with a peak SAR value greater than 0.0012W/kg
- Electronics: DAE4 Sn1486; Calibrated: 2023/6/16
- Probe: EX3DV4 - SN7369; ConvF(10.17, 10.17, 10.17) @ 750 MHz; Calibrated: 2023/5/22
- Sensor-Surface: 2mm (Mechanical Surface Detection)
- Phantom: ELI V5.0 (20deg probe tilt); Type: QD OVA 002 AA; Serial: 1240

### Configuration/Pin=250mW/Area Scan (7x13x1):

Measurement grid: dx=15mm, dy=15mm

Maximum value of SAR (measured) = 2.67 W/kg

### Configuration/Pin=250mW/Zoom Scan (5x5x7)/Cube 0:

Measurement grid: dx=8mm, dy=8mm, dz=5mm

Reference Value = 55.37 V/m; Power Drift = -0.01 dB

Peak SAR (extrapolated) = 3.09 W/kg

**SAR(1 g) = 2.18 W/kg; SAR(10 g) = 1.47 W/kg**

Smallest distance from peaks to all points 3 dB below = 21.5 mm

Ratio of SAR at M2 to SAR at M1 = 70.2%

Maximum value of SAR (measured) = 2.70 W/kg

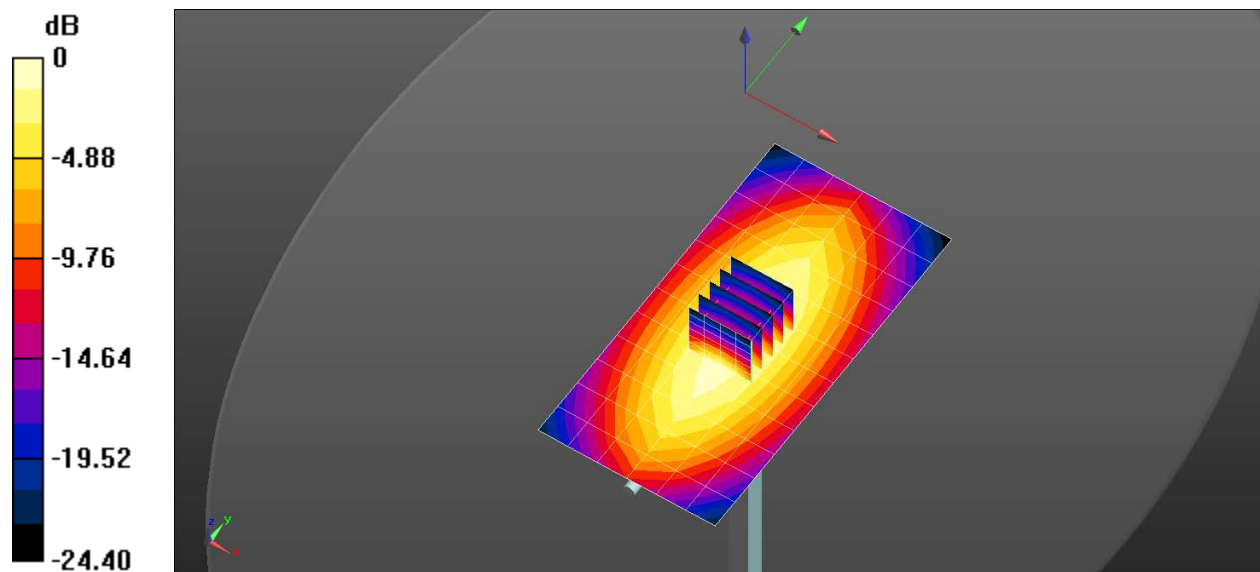

0 dB = 2.67 W/kg = 4.27 dBW/kg

## System Check\_H835

Frequency: 835 MHz; Duty Cycle: 1:1; Room Ambient Temperature: 23.0°C; Liquid Temperature: 22.0°C

Medium parameters used (interpolated):  $f = 835$  MHz;  $\sigma = 0.954$  S/m;  $\epsilon_r = 41.717$ ;  $\rho = 1000$  kg/m<sup>3</sup>

DASY5 Configuration:

- Area Scan Setting: Find Secondary Maximum Within: 2.0 dB and with a peak SAR value greater than 0.0012W/kg
- Electronics: DAE4 Sn1486; Calibrated: 2023/6/16
- Probe: EX3DV4 - SN7369; ConvF(9.83, 9.83, 9.83) @ 835 MHz; Calibrated: 2023/5/22
- Sensor-Surface: 2mm (Mechanical Surface Detection)
- Phantom: ELI V5.0 (20deg probe tilt); Type: QD OVA 002 AA; Serial: 1240

### Configuration/Pin=250mW/Area Scan (7x13x1):

Measurement grid: dx=15mm, dy=15mm

Maximum value of SAR (measured) = 3.06 W/kg

### Configuration/Pin=250mW/Zoom Scan (5x5x7)/Cube 0:

Measurement grid: dx=8mm, dy=8mm, dz=5mm

Reference Value = 58.46 V/m; Power Drift = 0.01 dB

Peak SAR (extrapolated) = 3.59 W/kg

**SAR(1 g) = 2.44 W/kg; SAR(10 g) = 1.59 W/kg**

Smallest distance from peaks to all points 3 dB below = 16 mm

Ratio of SAR at M2 to SAR at M1 = 67.3%

Maximum value of SAR (measured) = 3.10 W/kg

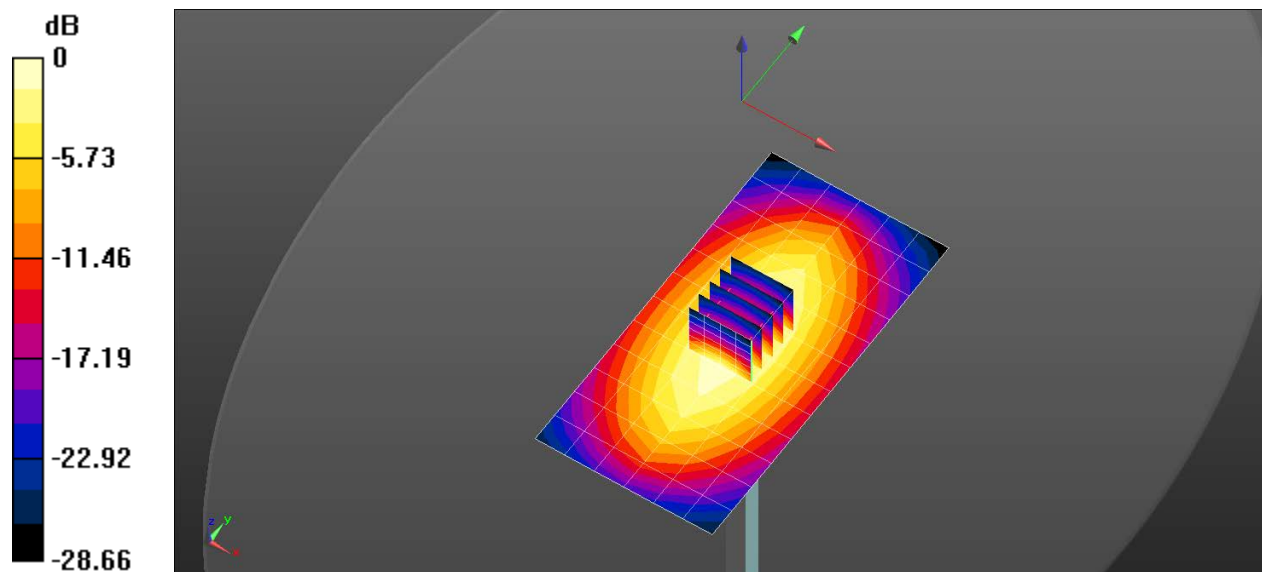

0 dB = 3.06 W/kg = 4.86 dBW/kg

## System Check\_H1800

Frequency: 1800 MHz; Duty Cycle: 1:1; Room Ambient Temperature: 23.0°C; Liquid Temperature: 22.0°C

Medium parameters used:  $f = 1800$  MHz;  $\sigma = 1.379$  S/m;  $\epsilon_r = 41.566$ ;  $\rho = 1000$  kg/m<sup>3</sup>

DASY5 Configuration:

- Area Scan Setting: Find Secondary Maximum Within: 2.0 dB and with a peak SAR value greater than 0.0012W/kg
- Electronics: DAE4 Sn1289; Calibrated: 2023/6/16
- Probe: EX3DV4 - SN7678; ConvF(9.06, 8.8, 8.69) @ 1800 MHz; Calibrated: 2023/8/17
- Sensor-Surface: 2mm (Mechanical Surface Detection (Locations From Previous Scan Used)), Sensor-Surface: 2mm (Mechanical Surface Detection)
- Phantom: ELI V8.0 (20deg probe tilt); Type: QD OVA 004 Ax; Serial: 2149

### Configuration/Pin=250mW/Area Scan (7x7x1):

Measurement grid: dx=15mm, dy=15mm

Maximum value of SAR (measured) = 14.3 W/kg

### Configuration/Pin=250mW/Zoom Scan (5x5x7)/Cube 0:

Measurement grid: dx=8mm, dy=8mm, dz=5mm

Reference Value = 105.0 V/m; Power Drift = 0.00 dB

Peak SAR (extrapolated) = 17.6 W/kg

**SAR(1 g) = 10.1 W/kg; SAR(10 g) = 5.35 W/kg**

Smallest distance from peaks to all points 3 dB below = 10.1 mm

Ratio of SAR at M2 to SAR at M1 = 57%

Maximum value of SAR (measured) = 14.2 W/kg

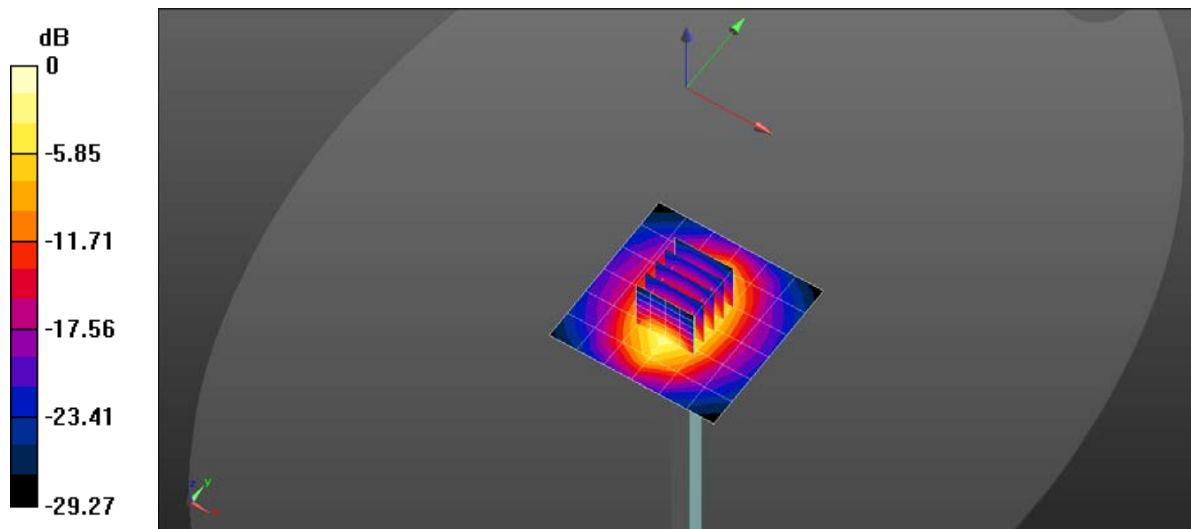

0 dB = 14.3 W/kg = 11.56 dBW/kg

## System Check\_H1900

Frequency: 1900 MHz; Duty Cycle: 1:1; Room Ambient Temperature: 23.0°C; Liquid Temperature: 22.0°C

Medium parameters used:  $f = 1900$  MHz;  $\sigma = 1.417$  S/m;  $\epsilon_r = 40.571$ ;  $\rho = 1000$  kg/m<sup>3</sup>

DASY5 Configuration:

- Area Scan Setting: Find Secondary Maximum Within: 2.0 dB and with a peak SAR value greater than 0.0012W/kg
- Electronics: DAE4 Sn1289; Calibrated: 2023/6/16
- Probe: EX3DV4 - SN7678; ConvF(8.91, 8.51, 8.47) @ 1900 MHz; Calibrated: 2023/8/17
- Sensor-Surface: 1.4mm (Mechanical Surface Detection)
- Phantom: ELI V8.0 (20deg probe tilt); Type: QD OVA 004 Ax; Serial: 2149

### Configuration/Pin=250mW/Area Scan (7x7x1):

Measurement grid: dx=15mm, dy=15mm

Maximum value of SAR (measured) = 13.2 W/kg

### Configuration/Pin=250mW/Zoom Scan (5x5x7)/Cube 0:

Measurement grid: dx=8mm, dy=8mm, dz=5mm

Reference Value = 94.87 V/m; Power Drift = 0.10 dB

Peak SAR (extrapolated) = 18.8 W/kg

**SAR(1 g) = 10.4 W/kg; SAR(10 g) = 5.42 W/kg**

Smallest distance from peaks to all points 3 dB below = 9.6 mm

Ratio of SAR at M2 to SAR at M1 = 55%

Maximum value of SAR (measured) = 16.0 W/kg

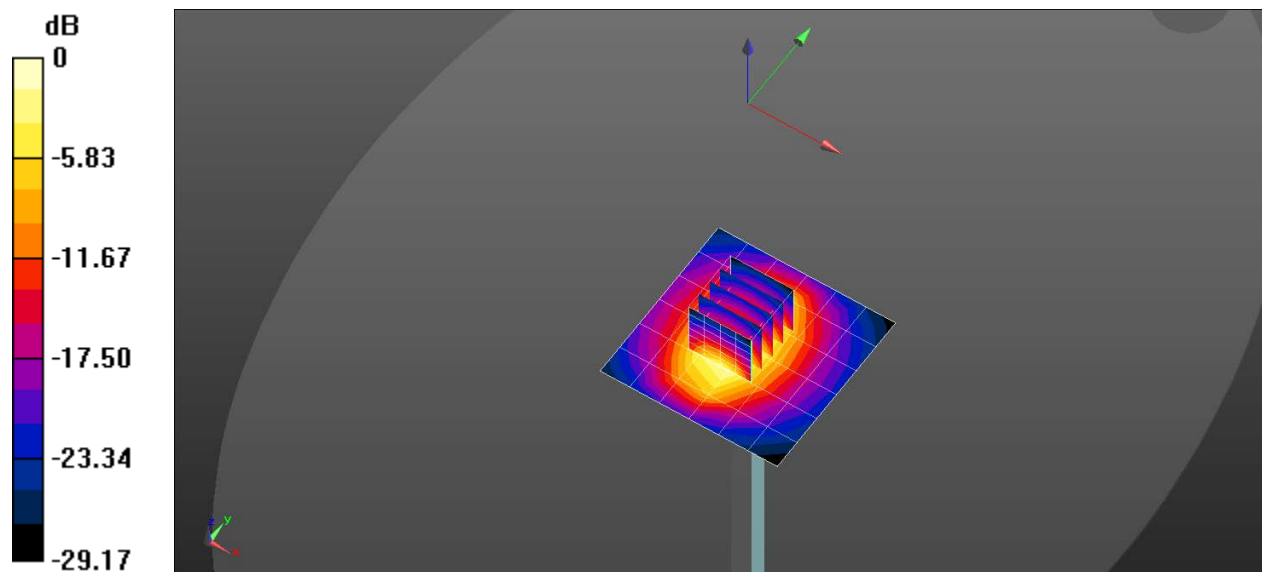

0 dB = 13.2 W/kg = 11.21 dBW/kg

## System Check\_H2300

Frequency: 2300 MHz; Duty Cycle: 1:1; Room Ambient Temperature: 23.0°C; Liquid Temperature: 22.0°C

Medium parameters used:  $f = 2300$  MHz;  $\sigma = 1.727$  S/m;  $\epsilon_r = 39.068$ ;  $\rho = 1000$  kg/m<sup>3</sup>

DASY5 Configuration:

- Area Scan Setting: Find Secondary Maximum Within: 2.0 dB and with a peak SAR value greater than 0.0012W/kg
- Electronics: DAE4 Sn1486; Calibrated: 2023/6/16
- Probe: EX3DV4 - SN7369; ConvF(7.89, 7.89, 7.89) @ 2300 MHz; Calibrated: 2023/5/22
- Sensor-Surface: 2mm (Mechanical Surface Detection (Locations From Previous Scan Used)), Sensor-Surface: 2mm (Mechanical Surface Detection)
- Phantom: ELI V5.0 (20deg probe tilt); Type: QD OVA 002 AA; Serial: 1240

### Configuration/Pin=250mW/Area Scan (9x9x1):

Measurement grid: dx=12mm, dy=12mm

Maximum value of SAR (measured) = 18.1 W/kg

### Configuration/Pin=250mW/Zoom Scan (7x7x7)/Cube 0:

Measurement grid: dx=5mm, dy=5mm, dz=5mm

Reference Value = 105.0 V/m; Power Drift = -0.09 dB

Peak SAR (extrapolated) = 24.9 W/kg

**SAR(1 g) = 12.4 W/kg; SAR(10 g) = 5.91 W/kg**

Smallest distance from peaks to all points 3 dB below = 10 mm

Ratio of SAR at M2 to SAR at M1 = 50.1%

Maximum value of SAR (measured) = 18.7 W/kg

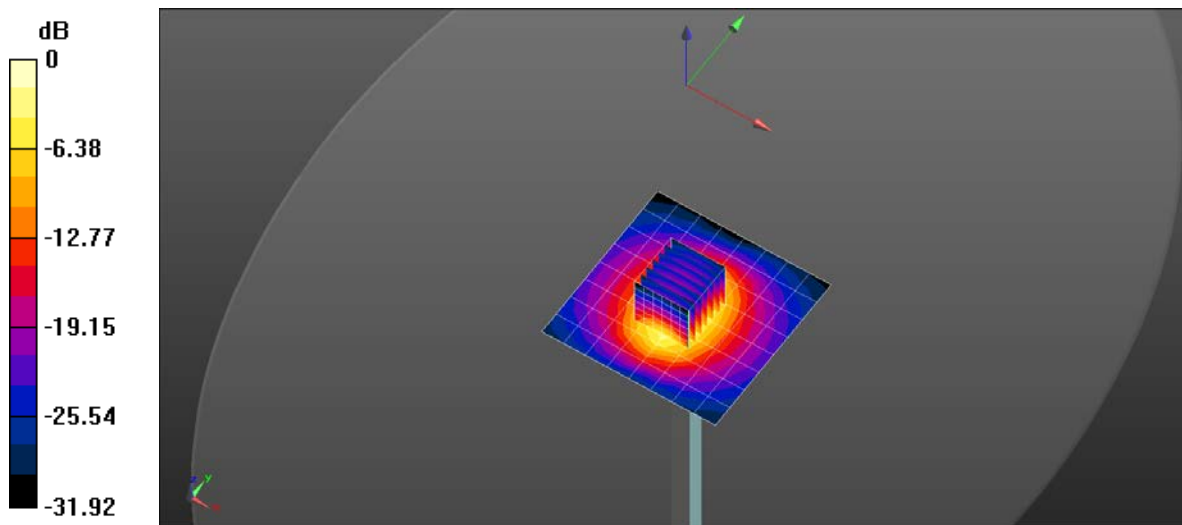

0 dB = 18.1 W/kg = 12.59 dBW/kg

## System Check\_H2600

Frequency: 2600 MHz; Duty Cycle: 1:1; Room Ambient Temperature: 23.0°C; Liquid Temperature: 22.0°C

Medium parameters used:  $f = 2600$  MHz;  $\sigma = 1.949$  S/m;  $\epsilon_r = 38.612$ ;  $\rho = 1000$  kg/m<sup>3</sup>

DASY5 Configuration:

- Area Scan Setting: Find Secondary Maximum Within: 2.0 dB and with a peak SAR value greater than 0.0012W/kg
- Electronics: DAE4 Sn1289; Calibrated: 2023/6/16
- Probe: EX3DV4 - SN7678; ConvF(8.42, 8, 8.03) @ 2600 MHz; Calibrated: 2023/8/17
- Sensor-Surface: 1.4mm (Mechanical Surface Detection (Locations From Previous Scan Used)), Sensor-Surface: 1.4mm (Mechanical Surface Detection)
- Phantom: ELI V8.0 (20deg probe tilt); Type: QD OVA 004 Ax; Serial: 2149

## System Performance Check at Frequencies above 1 GHz/Pin=250mW/Area Scan (9x9x1):

Measurement grid: dx=12mm, dy=12mm

Maximum value of SAR (measured) = 16.3 W/kg

## System Performance Check at Frequencies above 1 GHz/Pin=250mW/Zoom Scan (7x7x7)/Cube 0:

Measurement grid: dx=5mm, dy=5mm, dz=5mm

Reference Value = 96.47 V/m; Power Drift = -0.05 dB

Peak SAR (extrapolated) = 26.6 W/kg

**SAR(1 g) = 13.5 W/kg; SAR(10 g) = 6.16 W/kg**

Smallest distance from peaks to all points 3 dB below = 9 mm

Ratio of SAR at M2 to SAR at M1 = 51.4%

Maximum value of SAR (measured) = 22.2 W/kg

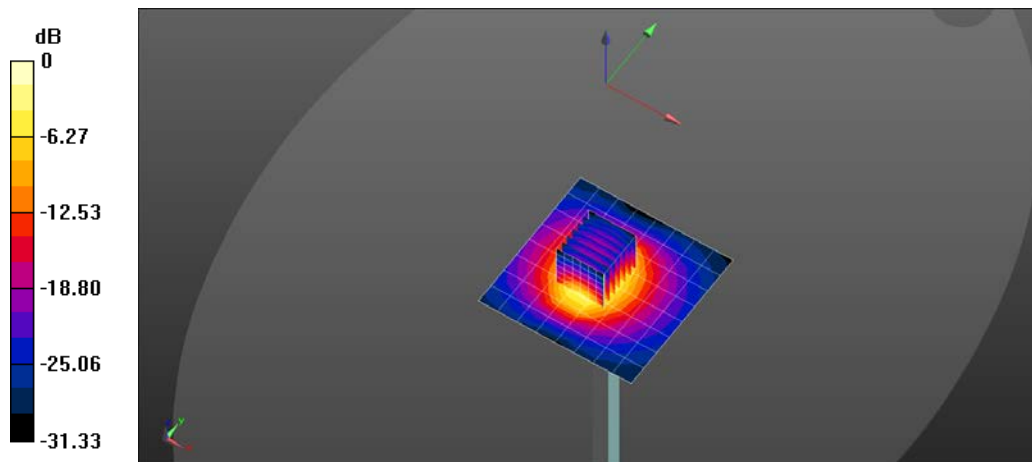

0 dB = 16.3 W/kg = 12.11 dBW/kg

## System Check\_H2600

Frequency: 2600 MHz; Duty Cycle: 1:1; Room Ambient Temperature: 23.0°C; Liquid Temperature: 22.0°C

Medium parameters used:  $f = 2600$  MHz;  $\sigma = 2.027$  S/m;  $\epsilon_r = 37.75$ ;  $\rho = 1000$  kg/m<sup>3</sup>

DASY5 Configuration:

- Area Scan Setting: Find Secondary Maximum Within: 2.0 dB and with a peak SAR value greater than 0.0012W/kg
- Electronics: DAE4 Sn1486; Calibrated: 2023/6/16
- Probe: EX3DV4 - SN7369; ConvF(7.48, 7.48, 7.48) @ 2600 MHz; Calibrated: 2023/5/22
- Sensor-Surface: 1.4mm (Mechanical Surface Detection)
- Phantom: ELI V5.0 (20deg probe tilt); Type: QD OVA 002 AA; Serial: 1240

## System Performance Check at Frequencies above 1 GHz/Pin=250mW/Area Scan (9x9x1):

Measurement grid: dx=12mm, dy=12mm

Maximum value of SAR (measured) = 21.5 W/kg

## System Performance Check at Frequencies above 1 GHz/Pin=250mW/Zoom Scan (7x7x7)/Cube 0:

Measurement grid: dx=5mm, dy=5mm, dz=5mm

Reference Value = 106.8 V/m; Power Drift = -0.00 dB

Peak SAR (extrapolated) = 27.4 W/kg

**SAR(1 g) = 13.3 W/kg; SAR(10 g) = 6.02 W/kg**

Smallest distance from peaks to all points 3 dB below = 8.5 mm

Ratio of SAR at M2 to SAR at M1 = 49.6%

Maximum value of SAR (measured) = 22.2 W/kg

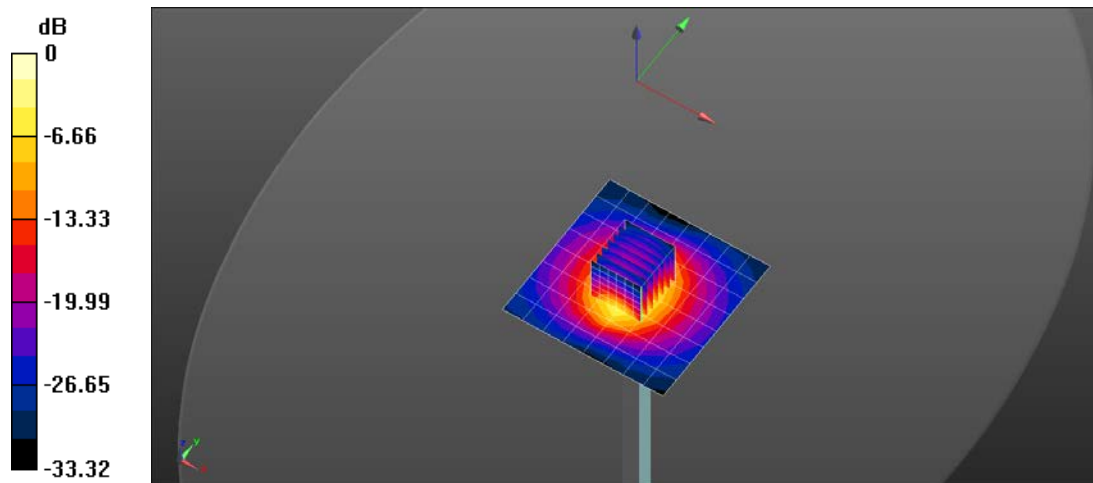

0 dB = 21.5 W/kg = 13.33 dBW/kg