



FCC RADIO TEST REPORT

FCC ID: 2AJMY-B13

Product : REMOTE

Trade Name : KEYDIY

Model Name : B13

Serial Model : N/A

Report No. : NTEK-2016NT08278639F

Prepared for

KEYDIY HK TECH LIMITED

Room1318-19, 13/F, Hollywood Plaza, 610 Nathan Road, Mongkok,
Kowloon, Hong Kong,China

Prepared by

NTEK Testing Technology Co., Ltd.

1/F, Building E, Fenda Science Park, Sanwei Community, Xixiang Street
Bao'an District, Shenzhen 518126 P.R. China

Tel.: +86-755-6115 6588 Fax.: +86-755-6115 6599

Website:<http://www.ntek.org.cn>

TEST RESULT CERTIFICATION

Applicant's name : KEYDIY HK TECH LIMITED

Address : Room1318-19, 13/F, Hollywood Plaza, 610 Nathan Road,
Mongkok, Kowloon, Hong Kong, China

Manufacturer's Name..... : ECARTEK

Address : Building #1 East Side, West Shahe Road, Chaguang Industrial
Park, Xili Town, NanShan District, Shenzhen City, Zip:518000,
China

Product description

Product name : REMOTE

Model and/or type reference : B13

Serial Model : N/A

Standards : FCC Part15.231 15 Sep. 2016

Test procedure..... ANSI C63.10-2013

This device described above has been tested by NTEK, and the test results show that the equipment under test (EUT) is in compliance with the FCC requirements. And it is applicable only to the tested sample identified in the report.

This report shall not be reproduced except in full, without the written approval of NTEK, this document may be altered or revised by NTEK, personal only, and shall be noted in the revision of the document.

Date of Test.....:

Date (s) of performance of tests : 27 Aug. 2016 ~ 13 Sep. 2016

Date of Issue..... : 13 Sep. 2016

Test Result..... : **Pass**

Testing Engineer : 

(Susan Su)

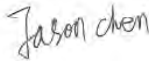
Technical Manager : 

(Jason Chen)

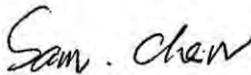
Authorized Signatory : 

(Sam Chen)

Table of Contents	Page
1 . SUMMARY OF TEST RESULTS	4
1.1 TEST FACILITY	5
1.2 MEASUREMENT UNCERTAINTY	5
2 . GENERAL INFORMATION	6
2.1 GENERAL DESCRIPTION OF EUT	6
2.2 DESCRIPTION OF TEST MODES	7
2.3 BLOCK DIGRAM SHOWING THE CONFIGURATION OF SYSTEM TESTED	8
2.4 DESCRIPTION OF SUPPORT UNITS(CONDUCTED MODE)	9
2.5 EQUIPMENTS LIST FOR ALL TEST ITEMS	10
3 . ANTENNA REQUIREMENT	11
3.1 STANDARD REQUIREMENT	11
3.2 EUT ANTENNA	11
3.3 CONDUCTED EMISSION MEASUREMENT	12
3.3.1 POWER LINE CONDUCTED EMISSION LIMITS	12
3.3.2 TEST PROCEDURE	13
3.3.3 DEVIATION FROM TEST STANDARD	13
3.3.4 TEST SETUP	13
3.2.5 TEST RESULT	14
3.4 RADIATED EMISSION MEASUREMENT	15
3.4.1 RADIATED EMISSION LIMITS	15
3.4.2 TEST PROCEDURE	16
3.4.3 DEVIATION FROM TEST STANDARD	16
3.4.4 TEST SETUP	17
3.4.5 TEST RESULTS (BELOW 30MHZ)	19
3.4.6 TEST RESULTS (BETWEEN 30 – 1000 MHZ)	20
3.4.7 TEST RESULTS (ABOVE 1000 MHZ)	22
3.4.8 DUTY CYCLE	23
4 . BANDWIDTH TEST	25
4.1 TEST PROCEDURE	25
4.2 DEVIATION FROM STANDARD	25
4.3 TEST SETUP	25
4.4 TEST RESULTS	26
5 . TRANSMITTER TIMEOUT	27
5.1 REQUIREMENTS	27
6 . EUT TEST PHOTO	28
APPENDIX-PHOTOGRAPHS OF EUT CONSTRUCTIONAL DETAILS	

1. SUMMARY OF TEST RESULTS

Test procedures according to the technical standards:

FCC Part15, Subpart C (15.231)			
Standard Section	Test Item	Judgment	Remark
15.207	Conducted Emission	N/A	Note(1)
15.203	Antenna Requirement	Pass	
15.231	Radiated Spurious Emission	Pass	
15.231	Occupied Bandwidth	Pass	
15.231	Transmitter Timeout	Pass	

NOTE:

(1) "N/A" denotes test is not applicable in this Test Report.

1.1 TEST FACILITY

NTEK Testing Technology Co., Ltd

Add. : 1/F, Building E, Fenda Science Park, Sanwei Community, Xixiang Street, Bao'an District, Shenzhen P.R. China.

FCC Registration No.:238937; IC Registration No.:9270A-1

CNAS Registration No.:L5516

1.2 MEASUREMENT UNCERTAINTY

The reported uncertainty of measurement $y \pm U$, where expanded uncertainty U is based on a standard uncertainty multiplied by a coverage factor of $k=2$, providing a level of confidence of approximately **95 %**.

No.	Item	Uncertainty
1	Conducted Emission Test	$\pm 1.38\text{dB}$
2	RF power,conducted	$\pm 0.16\text{dB}$
3	Spurious emissions,conducted	$\pm 0.21\text{dB}$
4	All emissions,radiated(<1G)	$\pm 4.68\text{dB}$
5	All emissions,radiated(>1G)	$\pm 4.89\text{dB}$
6	Temperature	$\pm 0.5^\circ\text{C}$
7	Humidity	$\pm 2\%$

2. GENERAL INFORMATION

2.1 GENERAL DESCRIPTION OF EUT

Equipment	REMOTE	
Trade Name	KEYDIY	
Model Name	B13	
Serial Model	N/A	
Model Difference	N/A	
Product Description	The EUT is a REMOTE	
	Operation Frequency	318MHz
	Modulation Type:	ASK
	Number Of Channel	1CH.
	Antenna Designation	PCB antenna
	Antenna Gain	5dBi
Based on the application, features, or specification exhibited in User's Manual, the EUT is considered as an ITE/Computing Device. More details of EUT technical specification, please refer to the User's Manual.		
Channel List	Refer to below	
Adapter	N/A	
Battery	DC3V	
Hardware Version	V1.0	
Software Version	V1.0	

Note:

1. For a more detailed features description, please refer to the manufacturer's specifications or the User's Manual.

2.

Channel	Frequency (MHz)
01	318
--	--

2.2 DESCRIPTION OF TEST MODES

To investigate the maximum EMI emission characteristics generates from EUT, the test system was pre-scanning tested base on the consideration of following EUT operation mode or test configuration mode which possible have effect on EMI emission level. Each of these EUT operation mode(s) or test configuration mode(s) mentioned above was evaluated respectively.

Pretest Mode	Description
Mode 1	TX

For Conducted Emission	
Final Test Mode	Description
Mode 1	TX

For Radiated Emission	
Final Test Mode	Description
Mode 1	TX

Note:

- (1) The EUT use new battery.
- (2) The EUT was programmed to be in continuously transmitting mode.
- (3) All the key in EUT(Lock, Trunk, Open)has been tested,but the "Lock"key is the worst case,only reported the worst case.

2.3 BLOCK DIGRAM SHOWING THE CONFIGURATION OF SYSTEM TESTED

Radiated Spurious Emission Test

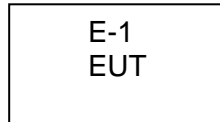

2.4 DESCRIPTION OF SUPPORT UNITS(CONDUCTED MODE)

The EUT has been tested as an independent unit together with other necessary accessories or support units. The following support units or accessories were used to form a representative test configuration during the tests.

Item	Equipment	Brand	Model/Type No.	Series No.	Note
E-1	REMOTE	KEYDIY	B13	N/A	EUT

Item	Shielded Type	Ferrite Core	Length	Note

Note:

- (1) The support equipment was authorized by Declaration of Confirmation.
- (2) For detachable type I/O cable should be specified the length in cm in 『Length』 column.

2.5 EQUIPMENTS LIST FOR ALL TEST ITEMS

Radiation Test equipment

Item	Kind of Equipment	Manufacturer	Type No.	Serial No.	Last calibration	Calibrated until	Calibration period
1	Spectrum Analyzer	Agilent	E4407B	MY45108040	2016.07.06	2017.07.05	1 year
2	Test Receiver	R&S	ESPI	101318	2016.06.07	2017.06.06	1 year
3	Bilog Antenna	TESEQ	CBL6111D	3916	2016.07.06	2017.07.05	1 year
4	50Ω Coaxial Switch	Anritsu	MP59B	6200264416	2016.06.07	2017.06.06	1 year
5	Spectrum Analyzer	ADVANTEST	R3132	150900201	2016.06.07	2017.06.06	1 year
6	Horn Antenna	EM	EM-AH-10180	2011071402	2016.07.06	2017.07.05	1 year
7	Amplifier	EM	EM-30180	060538	2015.9.22	2016.9.21	1 year
8	Loop Antenna	ARA	PLA-1030/B	1029	2016.06.08	2017.06.07	1 year
9	temporary antenna connector (Note)	NTS	R001	N/A	N/A	N/A	N/A

Note:

We will use the temporary antenna connector (soldered on the PCB board) When conducted test
And this temporary antenna connector is listed within the instrument list

3. ANTENNA REQUIREMENT

3.1 STANDARD REQUIREMENT

15.203 requirement: For intentional device, according to 15.203: an intentional radiator shall be designed to ensure that no antenna other than that furnished by the responsible party shall be used with the device.

3.2 EUT ANTENNA

The EUT antenna is PCB Antenna. It comply with the standard requirement.

3.3 CONDUCTED EMISSION MEASUREMENT

3.3.1 POWER LINE CONDUCTED EMISSION Limits (Frequency Range 150KHz-30MHz)

FREQUENCY (MHz)	Class A (dBuV)		Class B (dBuV)		Standard
	Quasi-peak	Average	Quasi-peak	Average	
0.15 -0.5			66 - 56 *	56 - 46 *	CISPR
0.50 -5.0			56.00	46.00	CISPR
5.0 -30.0			60.00	50.00	CISPR

0.15 -0.5			66 - 56 *	56 - 46 *	LP002.
0.50 -5.0			56.00	46.00	LP002.
5.0 -30.0			60.00	50.00	LP002.

Note:

- (1) The tighter limit applies at the band edges.
- (2) The limit of " * " marked band means the limitation decreases linearly with the logarithm of the frequency in the range.

The following table is the setting of the receiver

Receiver Parameters	Setting
Attenuation	10 dB
Start Frequency	0.15 MHz
Stop Frequency	30 MHz
IF Bandwidth	9 kHz

3.3.2 TEST PROCEDURE

- a. The EUT was placed 0.8 meters from the horizontal ground plane with EUT being connected to the power mains through a line impedance stabilization network (LISN). All other support equipments powered from additional LISN(s). The LISN provide 50 Ohm/ 50uH of coupling impedance for the measuring instrument.
- b. Interconnecting cables that hang closer than 40 cm to the ground plane shall be folded back and forth in the center forming a bundle 30 to 40 cm long.
- c. I/O cables that are not connected to a peripheral shall be bundled in the center. The end of the cable may be terminated, if required, using the correct terminating impedance. The overall length shall not exceed 1 m.
- d. LISN at least 80 cm from nearest part of EUT chassis.
- e. For the actual test configuration, please refer to the related Item –EUT Test Photos.

3.3.3 DEVIATION FROM TEST STANDARD

No deviation

3.3.4 TEST SETUP

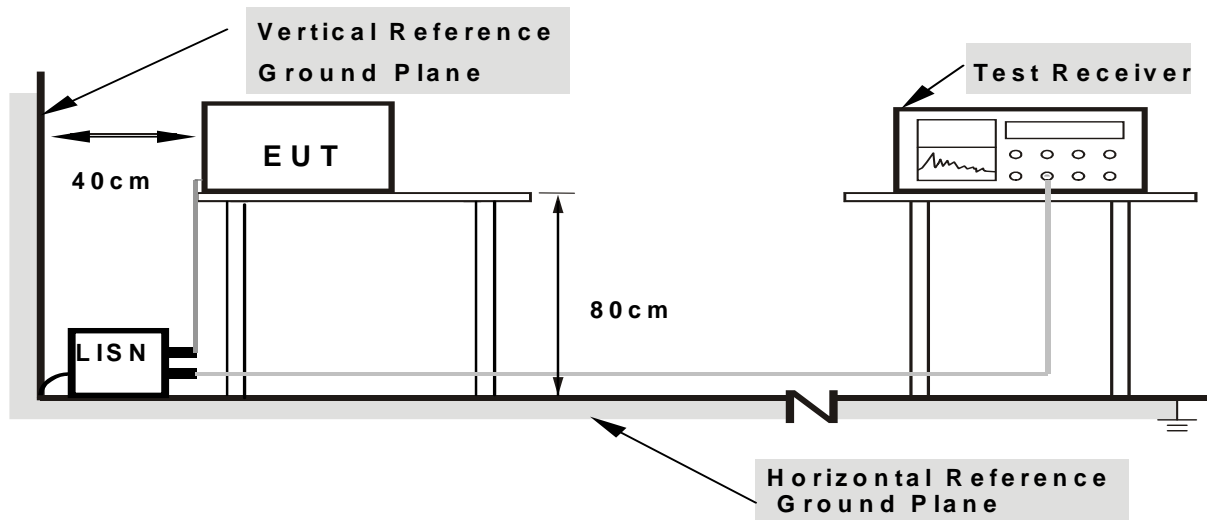

Note: 1. Support units were connected to second LISN.

2. Both of LISNs (AMN) are 80 cm from EUT and at least 80 cm from other units and other metal planes

3.2.5 TEST RESULT

EUT :	REMOTE	Model Name. :	B13
Temperature :	26 °C	Relative Humidity :	54%
Pressure :	1010hPa	Phase :	N/A
Test Voltage :	N/A	Test Mode :	N/A

N/A :means not applicable, Since the EUT's Power supplied from 3V battery.

3.4 RADIATED EMISSION MEASUREMENT

3.4.1 Radiated Emission Limits (FCC 15.209)

Frequencies (MHz)	Field Strength (micorvolts/meter)	Measurement Distance (meters)
0.009~0.490	2400/F(KHz)	300
0.490~1.705	24000/F(KHz)	30
1.705~30.0	30	30
30~88	100	3
88~216	150	3
216~960	200	3
Above 960	500	3

Note:

- (1) The tighter limit applies at the band edges.
- (2) Emission level (dBuV/m)=20log Emission level (uV/m).

LIMITS OF RADIATED EMISSION MEASUREMENT (FCC 15.231)

Fundamental Frequency (MHz)	Field Strength of fundamental (microvolts/meter)	Field Strength of Unwanted Emissions (microvolts/meter)
40.66 - 40.70	2250.00	225.00
70 - 130	950.00	95.00
130 - 174	1,250 to 3,750 **	95 to 375 **
174 - 260	3750.00	375.00
260 - 470	3,750 to 9,500 **	375 to 1,250 **
Above 470	9500.00	950.00

Notes:

- (1) ** linear interpolations

[Where F is the frequency in MHz, the formulas for calculating the maximum permitted fundamental field strengths are as follows: for the band 130-174 MHz, uV/m at 3 meters = 56.81818(F) - 6136.3636; for the band 260-470 MHz, uV/m at 3 meters = 41.6667(F) - 7083.3333. The maximum permitted unwanted emission level is 20 dB below the maximum permitted fundamental level.]

The limits on the field strength of the spurious emissions in the above table are based on the fundamental frequency of the intentional radiator. Spurious emissions shall be attenuated to the average (or, alternatively, CISPR quasi-peak) limits shown in this table or to the general limits shown in 93 Section 15.209, whichever limit permits a higher field strength.

Spectrum Parameter	Setting
Attenuation	Auto
Start Frequency	1000 MHz
Stop Frequency	10th carrier harmonic
RB / VB (emission in restricted band)	1MHz / 1MHz for Peak

Receiver Parameter	Setting
Attenuation	Auto
Start ~ Stop Frequency	9kHz~150kHz / RB 200Hz for QP
Start ~ Stop Frequency	150kHz~30MHz / RB 9kHz for QP
Start ~ Stop Frequency	30MHz~1000MHz / RB 90kHz for QP

3.4.2 TEST PROCEDURE

- a. The measuring distance of at 3 m shall be used for measurements at frequency up to 1GHz. For frequencies above 1GHz, any suitable measuring distance may be used.
- b. The EUT was placed on the top of a rotating table 0.8 m for below 1GHz and 1.5m for above 1GHz the ground at a 3 meter. The table was rotated 360 degrees to determine the position of the highest radiation.
- c. The height of the equipment or of the substitution antenna shall be 0.8 m for below 1GHz and 1.5m for above 1GHz; the height of the test antenna shall vary between 1 m to 4 m. Both horizontal and vertical polarizations of the antenna are set to make the measurement.
- d. For the radiated emission test above 1GHz:
Place the measurement antenna away from each area of the EUT determined to be a source of emissions at the specified measurement distance, while keeping the measurement antenna aimed at the source of emissions at each frequency of significant emissions, with polarization oriented for maximum response. The measurement antenna may have to be higher or lower than the EUT, depending on the radiation pattern of the emission and staying aimed at the emission source for receiving the maximum signal. The final measurement antenna elevation shall be that which maximizes the emissions. The measurement antenna elevation for maximum emissions shall be restricted to a range of heights of from 1 m to 4 m above the ground or reference ground plane.
- e. The initial step in collecting conducted emission data is a spectrum analyzer peak detector mode pre-scanning the measurement frequency range. Significant peaks are then marked and then Quasi Peak detector mode re-measured.
- f. If the Peak Mode measured value compliance with and lower than Quasi Peak Mode Limit, the EUT shall be deemed to meet QP Limits and then no additional QP Mode measurement performed.
- g. For the actual test configuration, please refer to the related Item –EUT Test Photos.

3.4.3 DEVIATION FROM TEST STANDARD

No deviation

3.4.4 TEST SETUP

(A) Radiated Emission Test-Up Frequency Below 30MHz

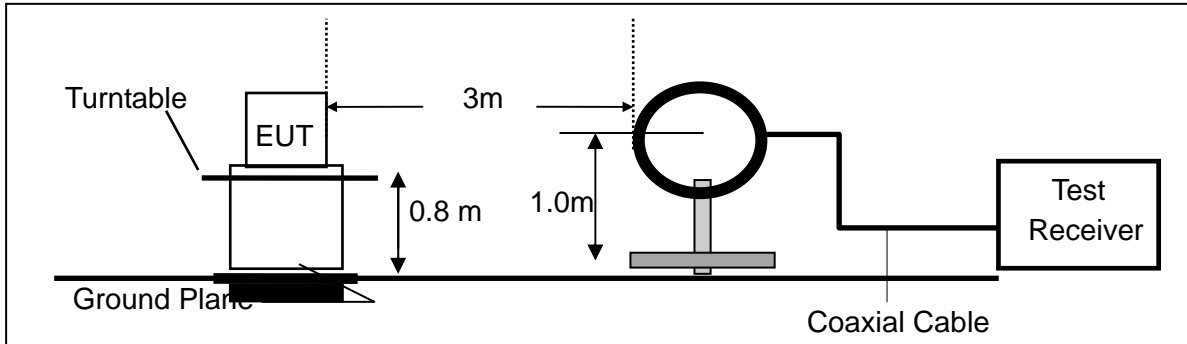

(B) Radiated Emission Test-Up Frequency 30MHz~1GHz

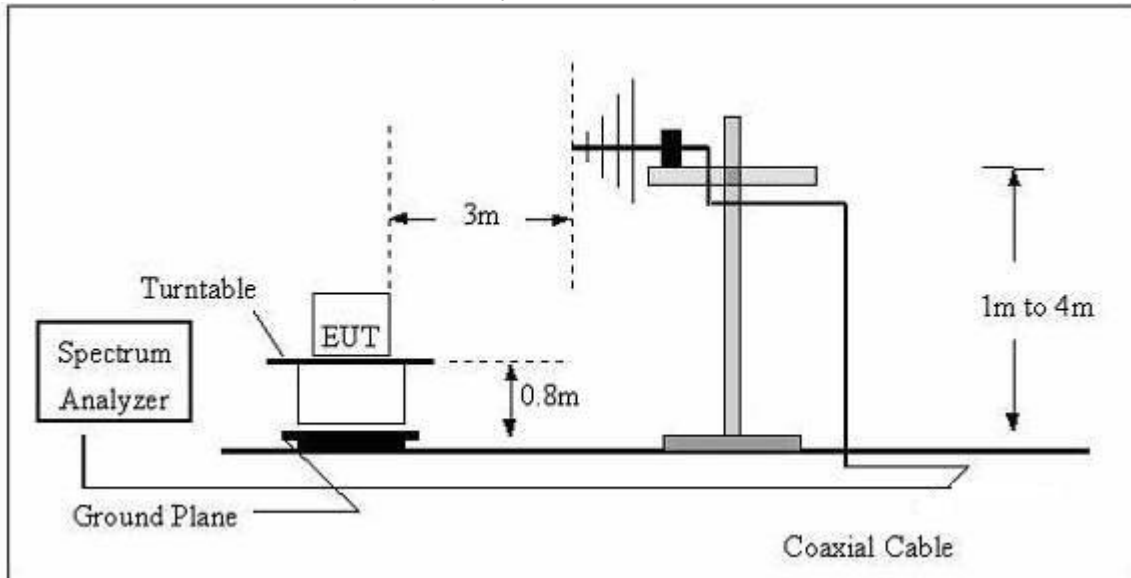

(C) Radiated Emission Test-Up Frequency Above 1GHz

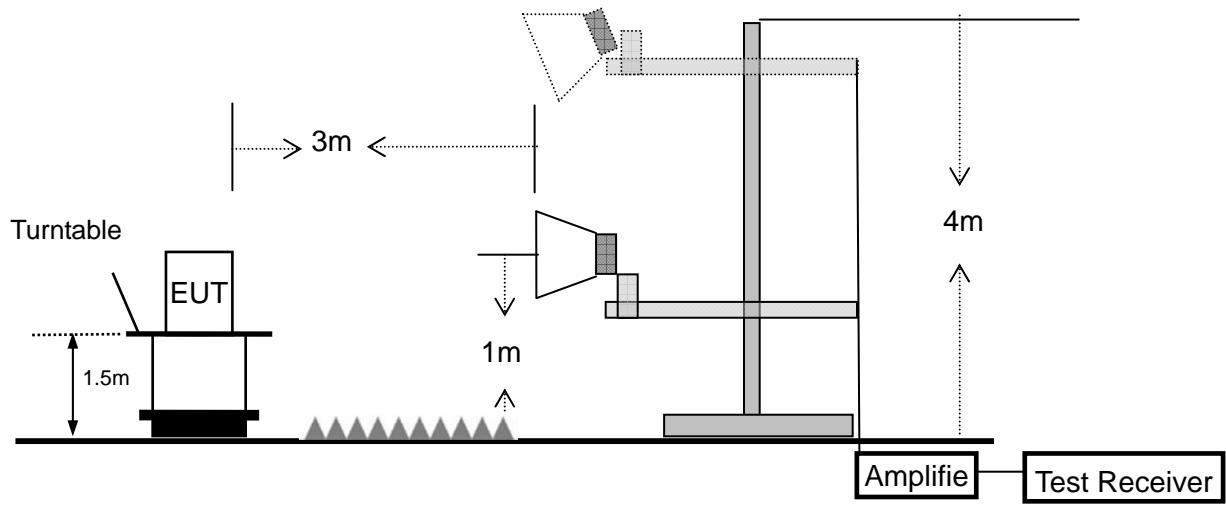

3.4.5 TEST RESULTS (BELOW 30MHz)

EUT :	REMOTE	Model Name. :	B13
Temperature :	20 °C	Relative Humidity :	48%
Pressure :	1010 hPa	Test Voltage :	DC 3V
Test Mode :	TX	Polarization :	--

Freq.	Reading	Limit	Margin	State
(MHz)	(dBuV/m)	(dBuV/m)	(dB)	P/F
--	--	--	--	PASS
--	--	--	--	PASS

NOTE:

The amplitude of spurious emissions which are attenuated by more than 20dB below the permissible value has no need to be reported.

Distance extrapolation factor = $40 \log (\text{specific distance}/\text{test distance})(\text{dB})$;

Limit line = specific limits(dBuv) + distance extrapolation factor.

3.4.6 TEST RESULTS (BETWEEN 30 – 1000 MHZ)

EUT :	REMOTE	Model Name :	B13
Temperature :	20 °C	Relative Humidity :	48%
Pressure :	1010 hPa	Test Voltage :	DC 3V
Test Mode :	TX	Polarization :	Horizontal

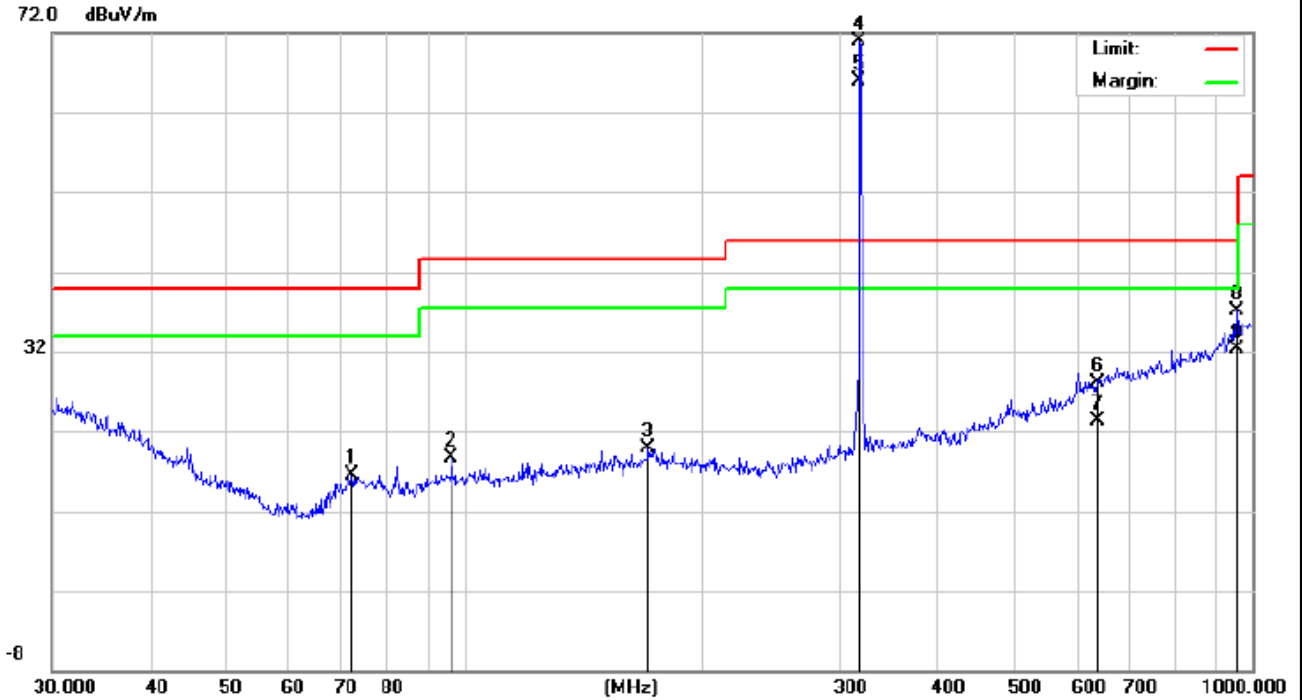

No.	Frequency (MHz)	Reading (dBuV/m)	Correct dB/m	Result (dBuV/m)	Limit (dBuV/m)	Over Limit (dB)	Remark
1	72.0841	5.99	10.54	16.53	40.00	-23.47	QP
2	96.4360	7.52	11.22	18.74	43.50	-24.76	QP
3	171.3925	6.37	13.57	19.94	43.50	-23.56	QP
4	318	56.42	14.43	70.85	95.8	-19.95	Peak
5	318	51.54	14.43	65.97	75.8	-4.83	AVG
6	636	6.77	21.36	28.13	75.8	-42.67	Peak
7	636	1.89	21.36	23.25	55.8	-27.55	AVG
8	954	9.29	27.80	37.09	75.8	-33.71	Peak
9	954	4.41	27.80	32.21	55.8	-18.59	AVG

Note: The average value of fundamental frequency is:

$$\text{Average} = \text{Peak Value} + 20\log(\text{Duty cycle}), \text{ Final Average} = \text{Peak} - 4.88$$

EUT :	REMOTE	Model Name :	B13
Temperature :	20 °C	Relative Humidity :	48%
Pressure :	1010 hPa	Test Voltage :	DC 3V
Test Mode :	TX	Polarization :	Vertical

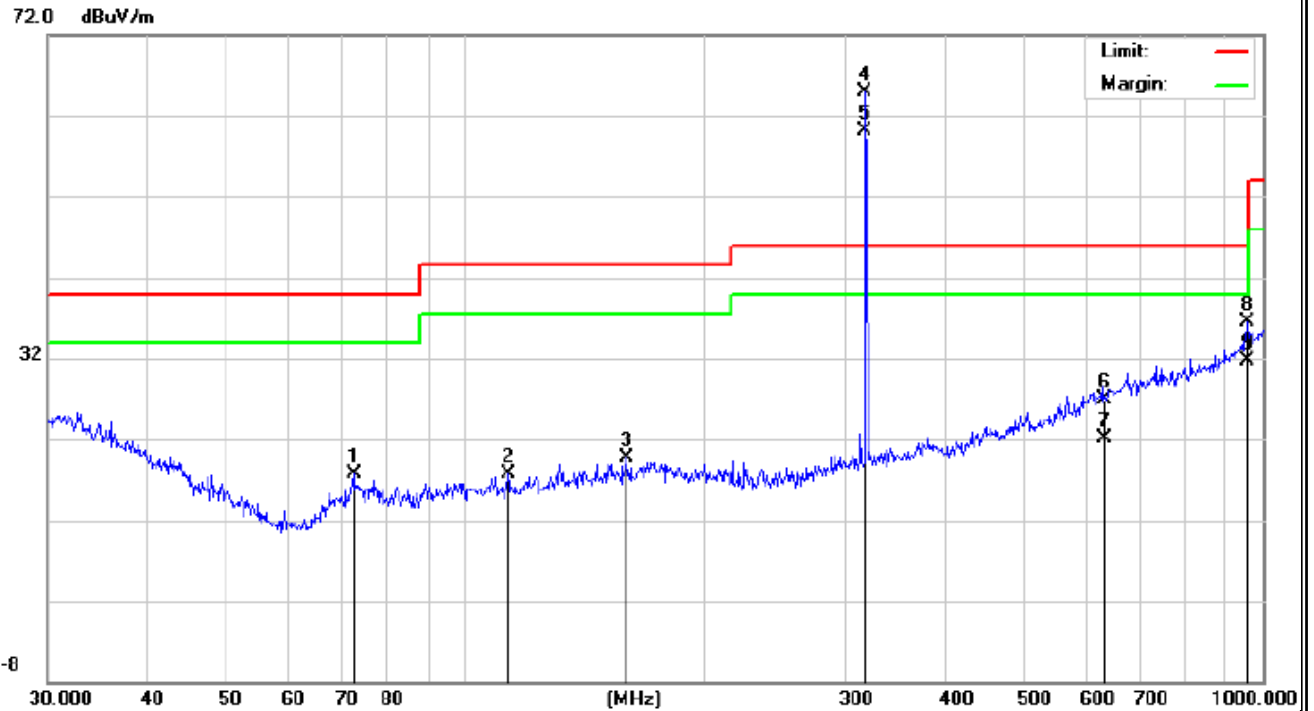

No.	Frequency (MHz)	Reading (dBuV/m)	Correct dB/m	Result (dBuV/m)	Limit (dBuV/m)	Over Limit (dB)	Remark
1	72.5916	7.10	10.58	17.68	40	-22.32	QP
2	113.3161	6.41	11.29	17.70	43.5	-25.8	QP
3	159.2247	7.19	12.54	19.73	43.5	-23.77	QP
4	318	50.57	14.43	65	95.8	-30.8	Peak
5	318	45.69	14.43	60.12	75.8	-15.68	AVG
6	636	5.59	21.36	26.95	75.8	-48.85	Peak
7	636	0.71	21.36	22.07	55.8	-33.73	AVG
8	954	8.73	27.8	36.53	75.8	-39.27	Peak
9	954	3.85	27.8	31.65	55.8	-24.15	AVG

Note: The average value of fundamental frequency is:
 Average= Peak Value+ 20log(Duty cycle), Final Average= Peak -4.88

3.4.7 TEST RESULTS (1000-3180 MHZ)

EUT :	REMOTE	Model Name :	B13
Temperature :	20 °C	Relative Humidity :	48%
Pressure :	1010 hPa	Test Voltage :	DC 3V
Test Mode :	TX	Polarization :	Horizontal

No.	Frequency	Reading	Correct Factor	Dutycycle Factor	Result	Limit	Over Limit	Remark
	(MHz)	(dBuV/m)	(dB)	(dB)	(dBuV/m)	(dBuV/m)	(dB)	
1	1272.12	22.85	12.41	-	35.26	75.80	-40.54	Peak
2	1590.18	33.37	13.49	-	46.86	74.00	-27.14	Peak
3	1908.03	21.67	16.57	-	38.24	75.80	-37.56	Peak
4	1272.12	-	-	-4.88	30.38	55.80	-25.42	AVG
5	1590.18	-	-	-4.88	41.98	54.00	-12.02	AVG
6	1908.03	-	-	-4.88	33.36	55.80	-22.44	AVG

EUT :	REMOTE	Model Name :	B13
Temperature :	20 °C	Relative Humidity :	48%
Pressure :	1010 hPa	Test Voltage :	DC 3V
Test Mode :	TX	Polarization :	Vertical

No.	Frequency	Reading	Correct Factor	Dutycycle Factor	Result	Limit	Over Limit	Remark
	(MHz)	(dBuV/m)	(dB)	(dB)	(dBuV/m)	(dBuV/m)	(dB)	
1	1272.02	22.94	13.43	-	36.37	75.80	-39.43	Peak
2	1590.13	26.05	13.49	-	39.54	74.00	-34.46	Peak
3	1908.24	16.54	17.91	-	34.45	75.80	-41.35	Peak
4	1272.02	-	-	-4.88	31.49	55.80	-24.31	AVG
5	1590.13	-	-	-4.88	34.66	54.00	-19.34	AVG
6	1908.24	-	-	-4.88	29.57	55.80	-26.23	AVG

Note: 1. EUT Pre-scan X/Y/Z orientation, only worst case is presented in the report(Y orientation).

2. *Calculate Average value based on Duty Cycle correction factor:

Duty Cycle=Ton/(Ton+Toff)= 30.9ms/54.2ms = 0.57=57%

Duty Cycle factor= 20lg (Duty Cycle) =20lg (0.57) = -4.88dB

Average=Peak+ Duty Cycle factor

2. FCC Limit for Average Measurement = 41.6667(318)-7083.3333 =6166.6773uV/m
=75.80dBuV/m

3. Pulse Desensitization Correction Factor

Pulse Width(PW)= 54.2ms 2/PW=2/54.2ms=0.0369kHz

RBW(100kHz) > 2/PW (0.0369kHz),

Therefore PDCF is not needed.

The “*” means restricted bands

3.4.8 DUTY CYCLE

The duty cycle is simply the on time divided by the period:

The duration of one cycle = 54.2ms

Effective period of the cycle = $1.1 \cdot 12 + 0.65 \cdot 20 + 4.7 \cdot 1 = 30.9\text{ms}$

Duty Cycle = $30.9\text{ms} / 54.2\text{ms} = 0.57$

The duration of one cycle

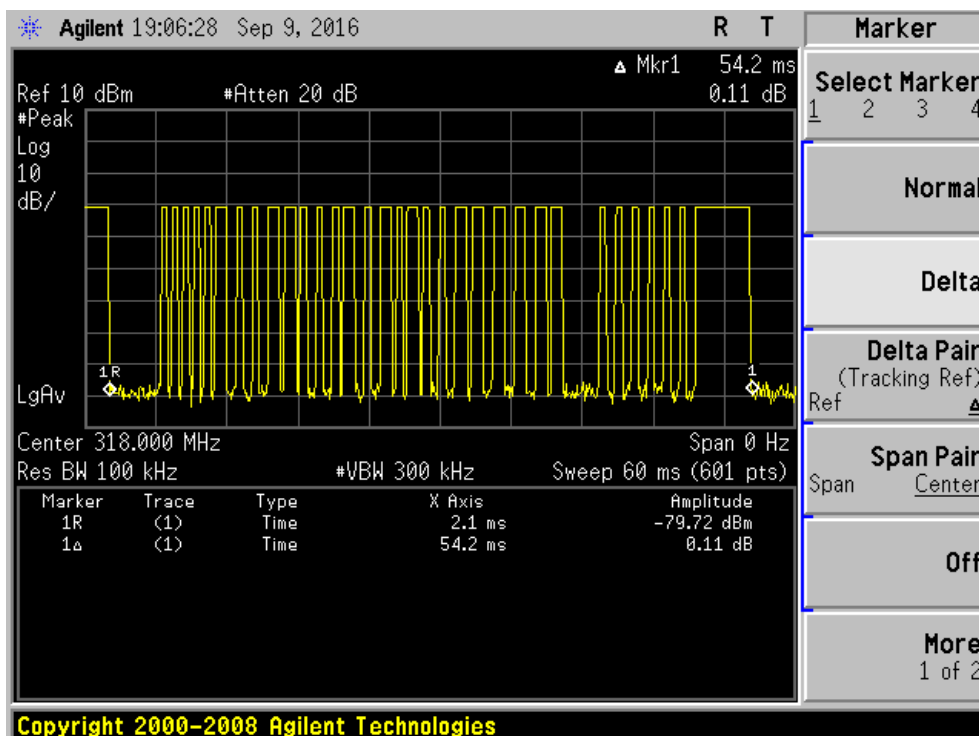
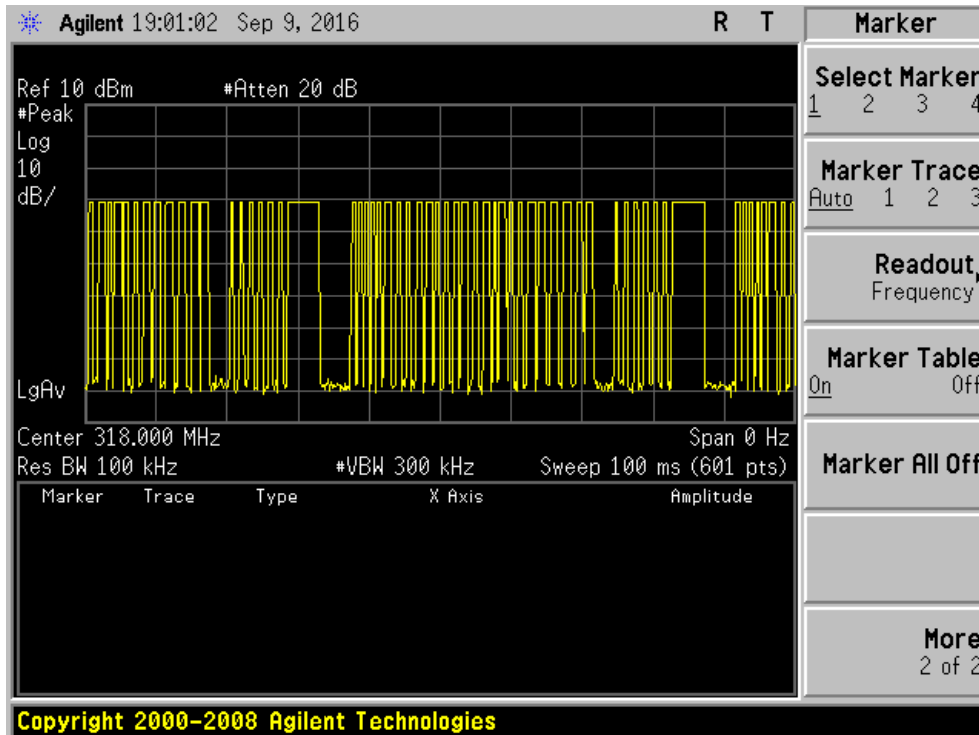

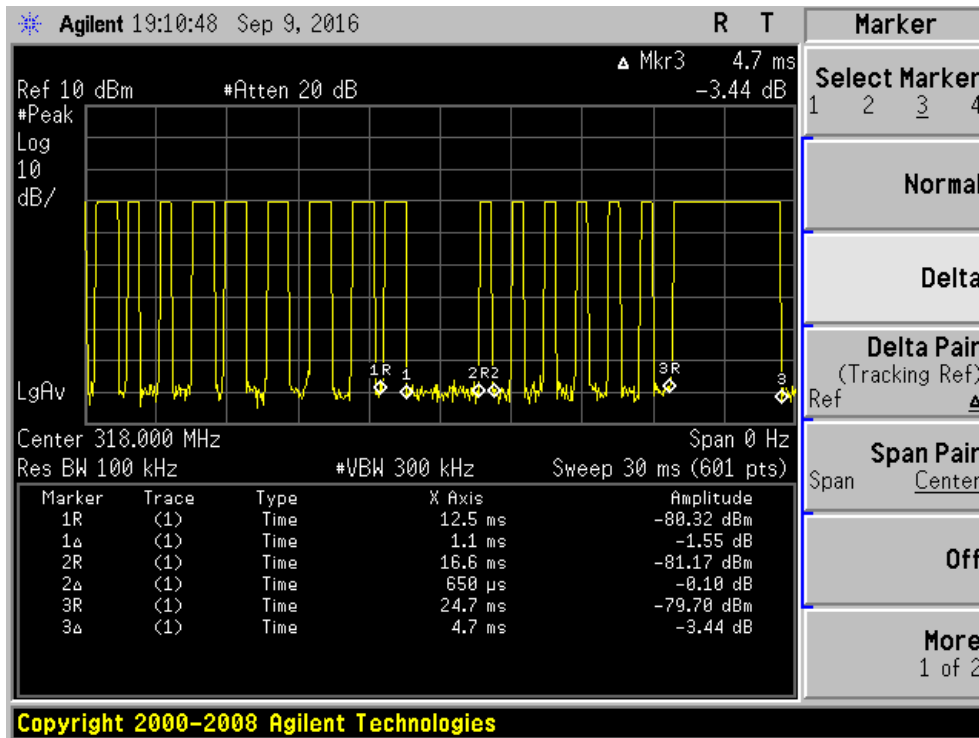

4. BANDWIDTH TEST

4.1 TEST PROCEDURE

The bandwidth of the emission shall be no wider than 0.25% of the center frequency for devices operating above 70 MHz and below 900 MHz. For devices operating above 900 MHz, the emission shall be no wider than 0.5% of the center frequency. Bandwidth is determined at the points 20 dB down from the modulated carrier.

Limit: $318\text{MHz} \times 0.25\% = 795\text{KHz}$

4.2 DEVIATION FROM STANDARD

No deviation.

4.3 TEST SETUP

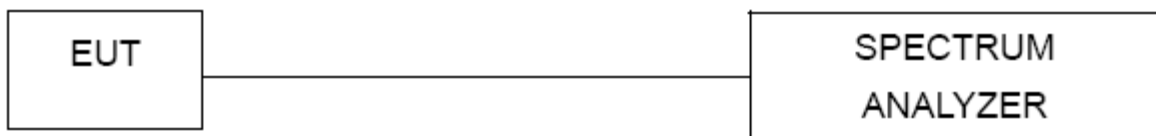

4.4 TEST RESULTS

EUT :	REMOTE	Model Name :	B13
Temperature :	26 °C	Relative Humidity :	53%
Pressure :	1020 hPa	Test Power :	DC 3V
Test Mode :	TX CH 1		

Test Channel	Frequency (MHz)	20 dBc Bandwidth (kHz)	Limit (kHz)
CH01	318	398.305	795

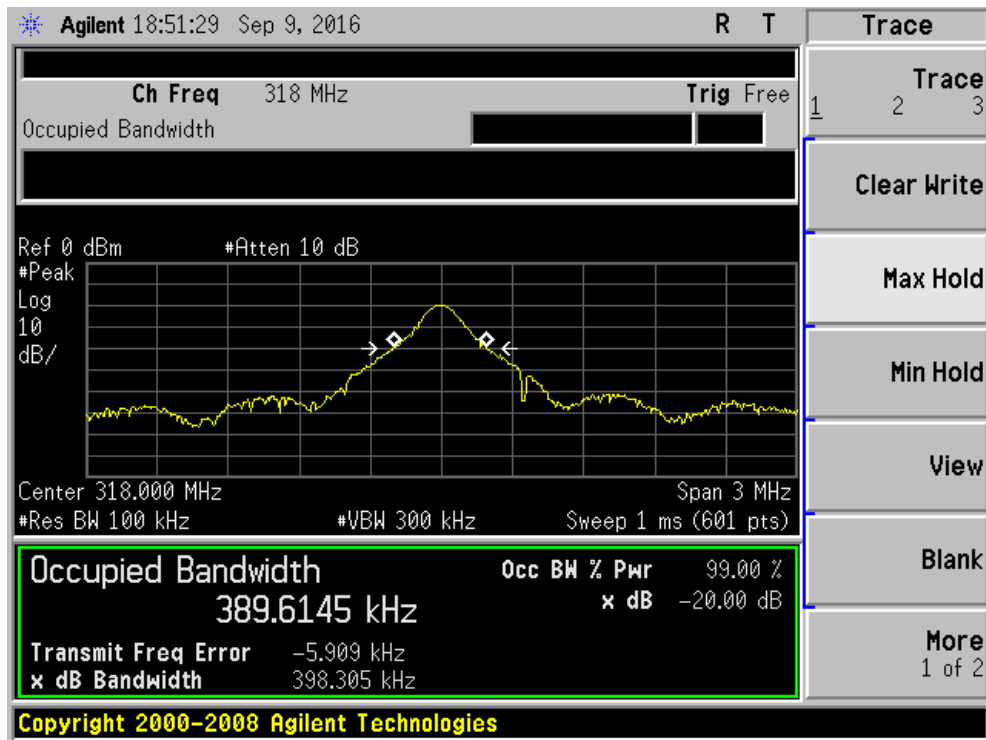

5. TRANSMITTER TIMEOUT

5.1 REQUIREMENTS

1	A manually operated transmitter shall employ a switch that will automatically deactivate the transmitter within not more than 5 seconds of being released. Result: The EUT has a manually activated transmitter.
2	A transmitter activated automatically shall cease transmission within 5 seconds after activation. Result: The EUT has a manually activated transmitter, please refer to below detail data.
3	Periodic transmissions at regular predetermined intervals are not permitted. However, polling or supervision transmissions, including data, to determine system integrity of transmitters used in security or safety applications are allowed if the total duration of transmissions does not exceed more than two seconds per hour for each transmitter. There is no limit on the number of individual transmissions, provided the total transmission time does not exceed two seconds per hour Result: The EUT does not employ periodic transmission.
4	Intentional radiators which are employed for radio control purposes during emergencies involving fire, security, and safety of life, when activated to signal an alarm, may operate during the pendency of the alarm condition. Result: The section is not applicable to EUT.

Test data

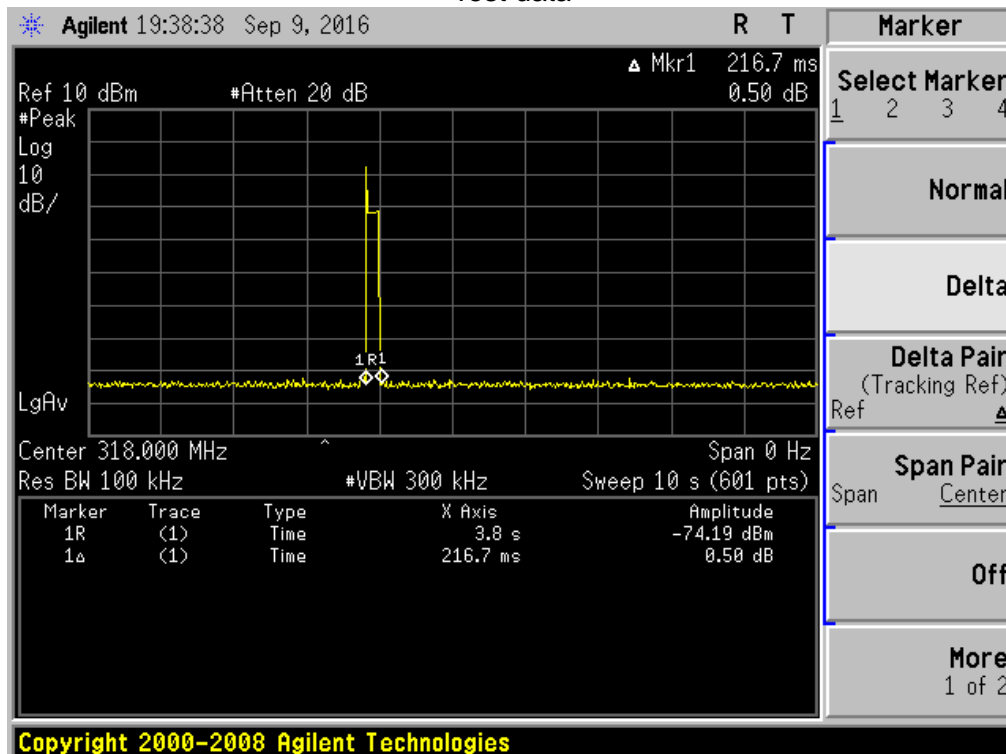

THE DURATION OF EACH TRANSMISSION	LIMIT	RESULT
0.2167s	<5s	PASS

6. EUT TEST PHOTO

Radiated Measurement Photos

