



FCC TEST REPORT FOR

Shanghai SmartPeak Technology Co.,Ltd.
POS Terminal
Test Model: P1000

Prepared for : Shanghai SmartPeak Technology Co.,Ltd.
Address : Block 2, No.20 Xuhongzhong Rd Xuhui District shanghai China

Prepared by : Shenzhen LCS Compliance Testing Laboratory Ltd.
 101, 201 Bldg A & 301 Bldg C, Juji Industrial Park
Address : Yabianxueziwei, Shajing Street, Baoan District, Shenzhen,
 518000, China

Tel : (+86)755-82591330
Fax : (+86)755-82591332
Web : www.LCS-cert.com
Mail : webmaster@LCS-cert.com

Date of receipt of test sample : July 15, 2022
Number of tested samples : 2
Sample No. : A071422048-1, A071422048-2
Serial number : Prototype
Date of Test : July 15, 2022 ~ August 09, 2022
Date of Report : August 10, 2022





FCC PART 24/27 TEST REPORT

FCC Part 24E/Part 27

Report Reference No.	LCSA071422048EG
FCC ID.	2AJMS-P1000
Date of Issue	August 10, 2022
Testing Laboratory Name	Shenzhen LCS Compliance Testing Laboratory Ltd.
Address	101, 201 Bldg A & 301 Bldg C, Juji Industrial Park Yabianxueziwei, Shajing Street, Baoan District, Shenzhen, 518000, China
Applicant's name	Shanghai SmartPeak Technology Co.,Ltd.
Address	Block 2, No.20 Xuhongzhong Rd Xuhui District shanghai China
Test specification	
Standard	FCC CFR Title 47 Part 2, Part 24E, Part 27 TIA-603-E: 2016 KDB971168 D01 Power Meas License Digital Systems v03r01
Test Report Form No	LCSEMC-1.0
TRF Originator	Shenzhen LCS Compliance Testing Laboratory Ltd.
Master TRF	Dated 2011-03
Shenzhen LCS Compliance Testing Laboratory Ltd. All rights reserved.	
This publication may be reproduced in whole or in part for non-commercial purposes as long as the Shenzhen LCS Compliance Testing Laboratory Ltd. is acknowledged as copyright owner and source of the material. Shenzhen LCS Compliance Testing Laboratory Ltd. takes no responsibility for and will not assume liability for damages resulting from the reader's interpretation of the reproduced material due to its placement and context.	
Test item description	POS Terminal
Trade Mark	SmartPeak
Test Model	P1000
Modulation Type	QPSK, 16QAM
Rating	Input: 5V \equiv 2A For Adapter Input: 100-240V~, 50/60Hz, 0.40A For Adapter Output: 5.0V \equiv 2.0A, 10.0W DC 7.4V by Rechargeable Li-ion Battery, 2000mAh
Hardware version	P5
Software version	V1.23.7539
Result	PASS

Compiled by:

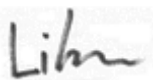

Li Huan/ Administrator

Supervised by:



Cary Luo/ Technique principal

Approved by:



Gavin Liang/ Manager





TEST REPORT

Test Report No. : LCSA071422048EG	August 10, 2022
	Date of issue

Equipment under Test : POS Terminal

Test Model : P1000

Applicant : **Shanghai SmartPeak Technology Co.,Ltd.**

Address : Block 2, No.20 Xuhongzhong Rd Xuhui District shanghai
China

Manufacturer : **Shanghai SmartPeak Technology Co.,Ltd.**

Address : Block 2, No.20 Xuhongzhong Rd Xuhui District shanghai
China

Factory : **Shanghai SmartPeak Technology Co.,Ltd.**

Address : Block 2, No.20 Xuhongzhong Rd Xuhui District shanghai
China

Test Result:	PASS
---------------------	-------------

The test report merely corresponds to the test sample.
It is not permitted to copy extracts of these test result without the written permission of the test laboratory.





Revision History

Report Version	Issue Date	Revision Content	Revised By
000	August 10, 2022	Initial Issue	---





Contents

1	<u>TEST STANDARDS</u>	6
2	<u>SUMMARY</u>	7
2.1	Product Description	7
2.2	Equipment under Test	9
2.3	Short description of the Equipment under Test (EUT)	9
2.4	Internal Identification of AE used during the test	9
2.5	Normal Accessory setting	9
2.6	Test Sample	9
2.7	EUT configuration	10
2.8	Related Submittal(s) / Grant (s)	10
2.9	Modifications	10
2.10	General Test Conditions/Configurations	10
3	<u>TEST ENVIRONMENT</u>	11
3.1	Address of the test laboratory	11
3.2	Test Facility	11
3.3	Environmental conditions	11
3.4	Test Description	11
3.5	Equipments Used during the Test	13
3.6	Measurement uncertainty	14
4	<u>TEST CONDITIONS AND RESULTS</u>	15
4.1	Output Power	15
4.2	Peak-to-Average Ratio (PAR)	24
4.3	Occupied Bandwidth and Emission Bandwidth	25
4.4	Band Edge compliance	26
4.5	Spurious Emssion on Antenna Port	27
4.6	Radiated Spurious Emssion	29
4.7	Frequency Stability under Temperature & Voltage Variations	35
5	<u>TEST SETUP PHOTOS OF THE EUT</u>	38
6	<u>EXTERNAL PHOTOS OF THE EUT</u>	38
7	<u>INTERNAL PHOTOS OF THE EUT</u>	38





1 TEST STANDARDS

The tests were performed according to following standards:

[FCC Part 24E](#): Broadband PCS

[FCC Part 27](#): MISCELLANEOUS WIRELESS COMMUNICATIONS SERVICES

[TIA-603-E March 2016](#): Land Mobile FM or PM Communications Equipment Measurement and Performance Standards.

[47 CFR FCC Part 15 Subpart B](#): Unintentional Radiators

[FCC Part 2](#): FREQUENCY ALLOCATIONS AND RADIO TREATY MATTERS; GENERAL RULES AND REGULATIONS

[ANSI C63.4:2014](#): Methods of Measurement of Radio-Noise Emissions from Low-Voltage Electrical and Electronic Equipment in the Range of 9 kHz to 40 GHz

[FCC KDB971168 D01](#) Power Meas License Digital Systems v03r01

[ANSI C63.26:2015](#): Compliance Testing of Transmitters Used in Licensed Radio Services





2 SUMMARY

2.1 Product Description

The **Shanghai SmartPeak Technology Co.,Ltd.**'s Model: P1000 or the "EUT" as referred to in this report; more general information as follows, for more details, refer to the user's manual of the EUT.

EUT	: POS Terminal
Test Model	: P1000
Power Supply	: Input: 5V \equiv 2A For Adapter Input: 100-240V~, 50/60Hz, 0.40A For Adapter Output: 5.0V \equiv 2.0A, 10.0W DC 7.4V by Rechargeable Li-ion Battery, 2000mAh
Hardware Version	: P5
Software Version	: V1.23.7539
Bluetooth	:
Frequency Range	: 2402MHz ~ 2480MHz
Channel Number	: 79 channels for Bluetooth V4.1(DSS) 40 channels for Bluetooth V4.1 (DTS)
Channel Spacing	: 1MHz for Bluetooth V4.1 (DSS) 2MHz for Bluetooth V4.1 (DTS)
Modulation Type	: GFSK, $\pi/4$ -DQPSK, 8-DPSK for Bluetooth V4.1(DSS) GFSK for Bluetooth V4.1 (DTS)
Bluetooth Version	: V4.1
Antenna Description	: PIFA Antenna, 0.5dBi(Max.)
WIFI(2.4G Band)	:
Frequency Range	: 2412MHz ~ 2462MHz
Channel Spacing	: 5MHz
Channel Number	: 11 Channels for 20MHz bandwidth (2412~2462MHz)
Modulation Type	: IEEE 802.11b: DSSS (CCK, DQPSK, DBPSK) IEEE 802.11g: OFDM (64QAM, 16QAM, QPSK, BPSK) IEEE 802.11n: OFDM (64QAM, 16QAM, QPSK, BPSK)
Antenna Description	: PIFA Antenna, 0.5dBi(Max.)
2G	:
Support Band	: <input type="checkbox"/> GSM 900 (EU-Band) <input type="checkbox"/> DCS 1800 (EU-Band) <input checked="" type="checkbox"/> GSM 850 (U.S.-Band) <input checked="" type="checkbox"/> PCS 1900 (U.S.-Band)
Release Version	: R99
GPRS Class	: Class 12
EGPRS Class	: Class 12
Type Of Modulation	: GMSK for GSM/GPRS; GMSK/8PSK for EGPRS
Antenna Description	: PIFA Antenna 0.5dBi (max.) For GSM 850 0.5dBi (max.) For PCS 1900
3G	:





Support Band : WCDMA Band II (U.S.-Band)
 WCDMA Band V (U.S.-Band)
 WCDMA Band IV (U.S.-Band)
 WCDMA Band I (EU-Band)
 WCDMA Band VIII (EU-Band)

Release Version : R9

Type Of Modulation : QPSK, 16QAM

Antenna Description : PIFA Antenna
0.5dBi (max.) For WCDMA Band II
0.5dBi (max.) For WCDMA Band V

LTE :

Support Band : E-UTRA Band 2(U.S.-Band)
 E-UTRA Band 4(U.S.-Band)
 E-UTRA Band 7(U.S.-Band)

LTE Release Version : R9

Type Of Modulation : QPSK/16QAM

Antenna Description : PIFA Antenna
0.5dBi (max.) For E-UTRA Band 2
0.5dBi (max.) For E-UTRA Band 4
0.5dBi (max.) For E-UTRA Band 7

Power Class : Class 3

NFC :

Operating Frequency : 13.56MHz

Modulation Type : ASK

Antenna Description : Internal, 0.5dBi(Max.)

GPS function : Support and only RX

Extreme temp. Tolerance : -30°C to +50°C

Extreme vol. Limits : 6.4VDC to 8.4VDC (nominal: 7.4VDC)





2.2 Equipment under Test

Power supply system utilised

Power supply voltage	:	<input type="radio"/> 120V/ 60 Hz	<input type="radio"/> 115V/60Hz
		<input type="radio"/> 12 V DC	<input type="radio"/> 24 V DC
		<input checked="" type="radio"/> Other (specified in blank below): 7.4V	

2.3 Short description of the Equipment under Test (EUT)

2.4.1 GeneralDescription

P1000 is subscriber equipment in the BT/BLE/2.4GWIFI/GSM/WCDMA/LTE/NFC/GPS system. GSM/GPRS/EGPRS frequency band is Band II/V. The HSPA/UMTS frequency band is Band II/V. LTE frequency band is band 2/4/7. The HSPA/UMTS frequency band II and Band V test data included in this report. The P1000 implements such functions as RF signal receiving/transmitting, GSM/GPRS/EGPRS/HSPA/UMTS/LTE protocol processing, video MMS service and etc. Externally it provides SIM card interface.

2.4 Internal Identification of AE used during the test

AE ID*	Description
AE1	Rechargeable Li-Polymer Battery
AE2	Switching Adapter

AE1

Battery Model: 524912

DC 7.4V by Rechargeable Li-ion Battery, 2000mAh

AE2

Adapter Model: GLH50D2000HW

Adapter Input: 100-240V~, 50/60Hz, 0.40A

Adapter Output: 5.0V---2.0A, 10.0W

2.5 Normal Accessory setting

Fully charged battery was used during the test.

2.6 Test Sample

The application provides 2 samples to meet requirement;

Sample Number	Description
Sample 1(A071422048-1)	Engineer sample – continuous transmit
Sample 2(A071422048-2)	Normal sample – Intermittent transmit





2.7 EUT configuration

The following peripheral devices and interface cables were connected during the measurement:

- - supplied by the manufacturer
- - supplied by the lab

○ Power Cable	Length (m) :	/
	Shield :	/
	Detachable :	/
○ Multimeter	Manufacturer :	/
	Model No. :	/

2.8 Related Submittal(s) / Grant (s)

This submittal(s) (test report) is intended for FCC ID: 2AJMS-P1000 filing to comply with Part 24 and Part 27 Rules

2.9 Modifications

No modifications were implemented to meet testing criteria.

2.10 General Test Conditions/Configurations

2.10.1 Test Environment

EnvironmentParameter	SelectedValuesDuringTests	
Relative Humidity	Ambient	
Temperature	TN	Ambient
Voltage	VL	DC 6.4V
	VN	DC 7.4V
	VH	DC 8.4V

NOTE:VL=lower extreme testvoltage VN=nominal voltage
VH=upper extreme testvoltage TN=normal temperature





3 TEST ENVIRONMENT

3.1 Address of the test laboratory

Shenzhen LCS Compliance Testing Laboratory Ltd

101, 201 Bldg A & 301 Bldg C, Juji Industrial Park Yabianxueziwei, Shajing Street, Baoan District, Shenzhen, 518000, China

The sites are constructed in conformance with the requirements of ANSI C63.4 (2014) and CISPR Publication 32.

3.2 Test Facility

The test facility is recognized, certified, or accredited by the following organizations:

NVLAP Accreditation Code is 600167-0.

FCC Designation Number is CN5024.

CAB identifier is CN0071.

CNAS Registration Number is L4595.

Test Firm Registration Number: 254912.

3.3 Environmental conditions

During the measurement the environmental conditions were within the listed ranges:

Temperature:	15-35 ° C
Humidity:	30-60 %
Atmospheric pressure:	950-1050mbar

3.4 Test Description

Band 2 (1850-1910MHz paired with 1930-1990MHz)

Test Item	FCC Rule No.	Requirements	Verdict
Effective(Isotropic) Radiated Output Power	§2.1046, §24.232	EIRP ≤ 2W	PASS
Peak-Average Ratio	§2.1046, §24.232	FCC:Limit≤13dB	PASS
Modulation Characteristics	§2.1047	Digital modulation	N/A
Bandwidth	§2.1049	OBW: No limit. EBW: No limit.	PASS
Band Edges Compliance	§2.1051, §24.238	≤ -13dBm/1%*EBW, In 1MHz bands immediately outside and adjacent to the frequency block.	PASS
Spurious Emission at Antenna Terminals	§2.1051, §24.238	≤-13dBm/1MHz, from 9kHz to 10 th harmonics but outside authorized Operating frequency ranges.	PASS
Field Strength of Spurious Radiation	§2.1053, §24.238	≤ -13dBm/1MHz.	PASS
Frequency Stability	§2.1055, §24.235	FCC: within authorized frequency block.	PASS

NOTE 1:For the verdict, the "N/A" denotes "not applicable",the "N/T" de notes "not tested".



**Band 4 (1710-1755MHz paired with 2110-2155MHz)**

Test Item	FCC RuleNo.	Requirements	Verdict
Effective(Isotropic) Radiated Power Output Data	§2.1046, §27.50(d)	EIRP ≤ 1W;	PASS
Peak-Average Ratio	§2.1046, §27.50(d)	Limit≤13dB	Pass
Modulation Characteristics	§2.1047	Digital modulation	N/A
Bandwidth	§2.1049	OBW: Nolimit. EBW: Nolimit.	PASS
BandEdges Compliance	§2.1051, §27.53(h)	≤ -13dBm/1%*EBW, in 1 MHz bands immediately outside and adjacent to the frequency block.	PASS
Spurious Emission at Antenna Terminals	§2.1051, §27.53(h)	≤ -13dBm/1MHz, from 9kHz to 10 th harmonics but outside authorized operating frequency ranges.	PASS
Frequency Stability	§2.1055, §27.54	Within authorized bands of operation/frequency block.	PASS
Radiated spurious emission	§2.1053, §27.53(h)	≤ -13dBm/1MHz.	PASS

NOTE 1: For the verdict, the "N/A" denotes "not applicable", the "N/T" de notes "not tested"

Band 7 (2500-2570MHz paired with 2620-2690MHz)

Test Item	FCC Rule No.	Requirements	Verdict
Effective(Isotropic) Radiated Output Power	§2.1046, §27.50(h)	FCC: EIRP ≤ 2W.	Pass
Peak-AverageRatio	§2.1046, §27.50(a)	Limit≤13dB	Pass
Modulation Characteristics	§2.1047	Digital modulation	N/A
Bandwidth	§2.1049	OBW: No limit. EBW: No limit.	Pass
Band Edges Compliance	§2.1051, §27.53(m)	More details specified in §27.53(m)(4)	Pass
Spurious Emission at Antenna Terminals	§2.1051, §27.53(m)	More details specified in §27.53(m)(4)	Pass
Field Strength of Spurious Radiation	§2.1053, §27.53(m)	More details specified in §27.53(m)(4)	Pass
Frequency Stability	§2.1055, §27.54	≤ ±2.5ppm.	Pass

NOTE 1: For the verdict, the "N/A" denotes "not applicable", the "N/T" de notes "not tested".



Shenzhen LCS Compliance Testing Laboratory Ltd.

Add: 101, 201 Bldg A & 301 Bldg C, Juji Industrial Park Yabianxueziwei, Shajing Street, Baoan District, Shenzhen, 518000, China

Tel: +(86) 0755-82591330 | E-mail: webmaster@lcs-cert.com | Web: www.lcs-cert.com

Scan code to check authenticity



3.5 Equipments Used during the Test

Item	Equipment	Manufacturer	Model No.	Serial No.	Cal Date	Due Date
1	Power Meter	R&S	NRVS	100444	2022-06-16	2023-06-15
2	Power Sensor	R&S	NRV-Z81	100458	2022-06-16	2023-06-15
3	Power Sensor	R&S	NRV-Z32	10057	2022-06-16	2023-06-15
4	LTE Test Software	Tonscend	JS1120-1	N/A	N/A	N/A
5	RF Control Unit	Tonscend	JS0806-1	158060009	2022-06-16	2023-06-15
6	MXA Signal Analyzer	Agilent	N9020A	MY51250905	2021-11-16	2022-11-15
7	WIDEBAND RADIO COMMUNICATION TESTER	R&S	CMW 500	103818	2022-06-16	2023-06-15
8	DC Power Supply	Agilent	E3642A	N/A	2021-11-15	2022-11-14
9	EMI Test Software	AUDIX	E3	/	N/A	N/A
10	3m Semi Anechoic Chamber	SIDT FRANKONIA	SAC-3M	03CH03-HY	2022-06-16	2023-06-15
11	Positioning Controller	Max-Full	MF7802BS	MF780208586	N/A	N/A
12	Active Loop Antenna	SCHWARZBECK	FMZB 1519B	00005	2021-08-29	2024-08-28
13	By-log Antenna	SCHWARZBECK	VULB9163	9163-470	2021-09-12	2024-09-11
14	Horn Antenna	SCHWARZBECK	BBHA 9120D	9120D-1925	2021-09-05	2024-09-04
15	Broadband Horn Antenna	SCHWARZBECK	BBHA 9170	791	2021-08-29	2024-08-28
16	Broadband Preamplifier	SCHWARZBECK	BBV9719	9719-025	2022-06-16	2023-06-15
17	EMI Test Receiver	R&S	ESR 7	101181	2022-06-16	2023-06-15
18	RS SPECTRUM ANALYZER	R&S	FSP40	100503	2021-11-16	2022-11-15
19	Broadband Preamplifier	/	BP-01M18G	P190501	2022-06-16	2023-06-15
20	6dB Attenuator	/	100W/6dB	1172040	2022-06-16	2023-06-15
21	3dB Attenuator	/	2N-3dB	/	2021-11-15	2022-11-14
22	Temperature & Humidity Chamber	GUANGZHOU GOGNWEN	GDS-100	70932	2021-10-07	2022-10-06
23	EMI Test Software	Farad	EZ	/	N/A	N/A





3.6 Measurement uncertainty

The data and results referenced in this document are true and accurate. The reader is cautioned that there may be errors within the calibration limits of the equipment and facilities. The measurement uncertainty was calculated for all measurements listed in this test report acc. to ETSI TR 100 028 "Electromagnetic compatibility and Radio spectrum Matters (ERM); Uncertainties in the measurement of mobile radio equipment characteristics" and is documented in the Shenzhen LCS Compliance Testing Laboratory Ltd. quality system acc. to DIN EN ISO/IEC 17025. Furthermore, component and process variability of devices similar to that tested may result in additional deviation. The manufacturer has the sole responsibility of continued compliance of the device.

Hereafter the best measurement capability for Shenzhen LCS Compliance Testing Laboratory Ltd. is reported:

Test	Range	Measurement Uncertainty	Notes
Radiated Emission	30~1000MHz	3.10 dB	(1)
Radiated Emission	1~18GHz	3.80 dB	(1)
Radiated Emission	18-40GHz	3.90 dB	(1)
Conducted Disturbance	0.15~30MHz	1.63 dB	(1)
Conducted Power	9KHz~18GHz	0.61 dB	(1)
Spurious RF Conducted Emission	9KHz~40GHz	1.22 dB	(1)
Band Edge Compliance of RF Emission	9KHz~40GHz	1.22 dB	(1)
Occupied Bandwidth	9KHz~40GHz	-	(1)

(1) This uncertainty represents an expanded uncertainty expressed at approximately the 95% confidence level using a coverage factor of k=1.96.





4 TEST CONDITIONS AND RESULTS

4.1 Output Power

TEST APPLICABLE

During the process of testing, the EUT was controlled via R&S Digital Radio Communication tester (CMW 500) to ensure max power transmission and proper modulation. This result contains output power and EIRP measurements for the EUT. In all cases, output power is within the specified limits.

4.1.1. Conducted Output Power

TEST CONFIGURATION

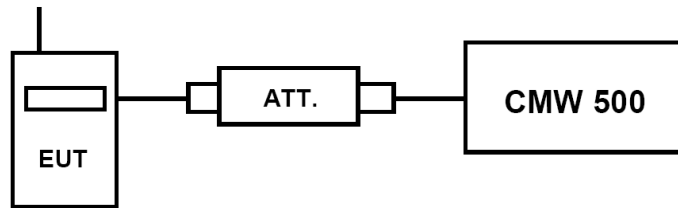

TEST PROCEDURE

Conducted Power Measurement:

- Place the EUT on a bench and set it in transmitting mode.
- Connect a low loss RF cable from the antenna port to a CMW 500 by an Att.
- EUT Communicate with CMW 500 then selects a channel for testing.
- Add a correction factor to the display CMW 500, and then test.

TEST RESULTS

Remark:

- We were tested all RB Configuration refer 3GPP TS136 521 for each Channel Bandwidth of LTE FDD Band 2, LTE FDD Band 4, LTE FDD Band 7; recorded worst case for each Channel Bandwidth of LTE FDD Band 2, LTE FDD Band 4, LTE FDD Band 7.
- For E-UTRA Band 2, please refer to Appendix D: Section D.1
- For E-UTRA Band 4, please refer to Appendix E: Section E.1
- For E-UTRA Band 7, please refer to Appendix F: Section F.1



4.1.2. Radiated Output Power

LIMIT

This is the test for the maximum radiated power from the EUT.

Per §22.913(2) Extend coverage on a secondary basis into cellular unserved areas, as those areas are defined in §22.949, the ERP of base transmitters and cellular repeaters of such systems must not exceed 1000 Watts. The ERP of mobile transmitters and auxiliary test transmitters must not exceed 7 Watts.

Rule Part 24.232(c) specifies, "Mobile/portable stations are limited to 2 watts e.i.r.p. Peak power" and 24.232(e) specifies that "Peak transmit power must be measured over any interval of continuous transmission using instrumentation calibrated in terms of an rms-equivalent voltage."

Per Part 27.50(d) (4) specifies, Fixed, mobile, and portable (hand-held) stations operating in the 1710-1755MHz band are limited to 1W EIRP. Fixed stations operating in this band are limited to a maximum antenna height of 10 meters above ground. Mobile and portable stations operating in this band must employ a means for limiting power to the minimum necessary for successful communications.

Per Part 27.50(c) (10) specifies, Portable stations (hand-held devices) in the 600 MHz uplink band and the 698-746 MHz band, and fixed and mobile stations in the 600 MHz uplink band are limited to 3 watts ERP.

Per Part 27.50(h) (2) specifies Mobile and other user stations. Mobile stations are limited to 2.0 watts EIRP. All user stations are limited to 2.0 watts transmitter output power.

Per Part 90.635(b) The maximum output power of the transmitter for mobile stations is 100 watts (20 dBw).

TEST CONFIGURATION

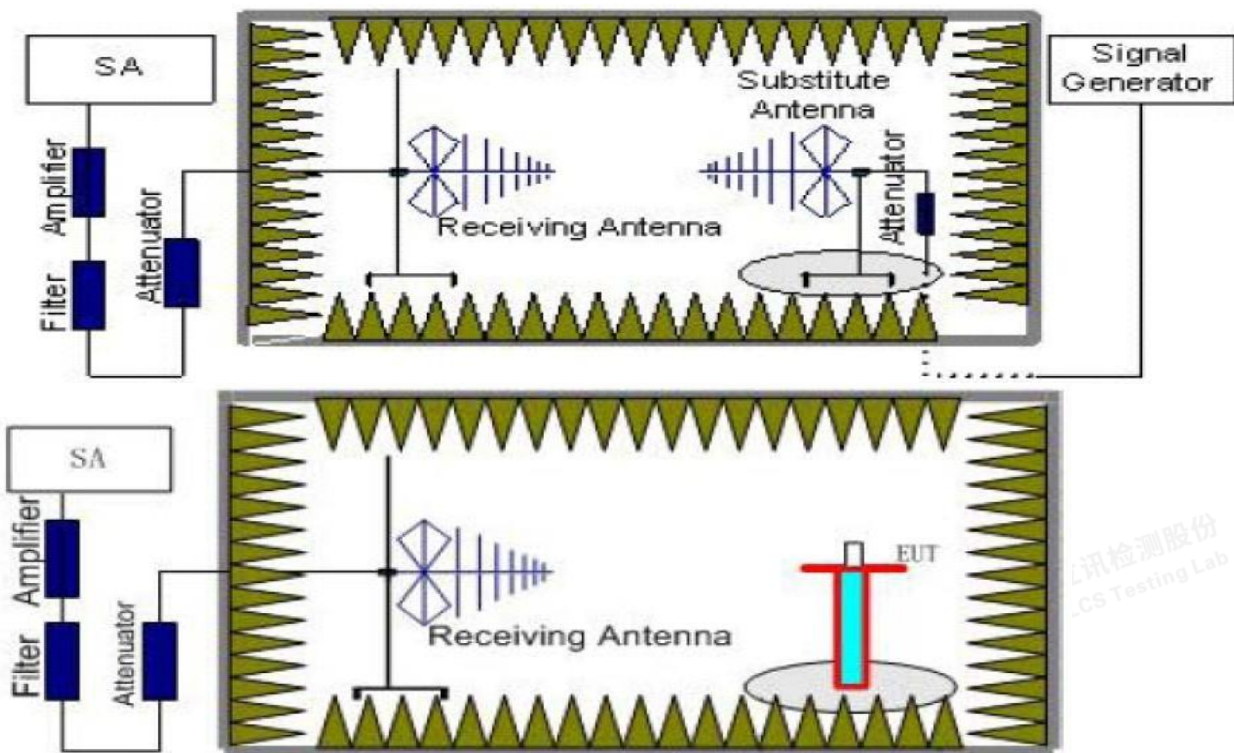

TEST PROCEDURE

1. EUT was placed on a 1.50 meter high non-conductive stand at a 3 meter test distance from the receive antenna. A receiving antenna was placed on the antenna mast 3 meters from the EUT for emission measurements. The height of receiving antenna is 1.50m. Detected emissions were maximized at each frequency by rotating the EUT through 360° and adjusting the receiving antenna polarization. The radiated emission measurements of all transmit frequencies in three channels (High, Middle, Low) were measured with peak detector.





2. A log-periodic antenna or double-ridged waveguide horn antenna shall be substituted in place of the EUT. The log-periodic antenna will be driven by a signal generator and the level will be adjusted till the same power value on the spectrum analyzer or receiver. The level of the spurious emissions can be calculated through the level of the signal generator, cable loss, the gain of the substitution antenna and the reading of the spectrum analyzer or receiver.
3. The EUT is then put into continuously transmitting mode at its maximum power level during the test. Set Test Receiver or Spectrum RBW=1MHz, VBW=3MHz, And the maximum value of the receiver should be recorded as (P_r).
4. The EUT shall be replaced by a substitution antenna. In the chamber, an substitution antenna for the frequency band of interest is placed at the reference point of the chamber. An RF Signal source for the frequency band of interest is connected to the substitution antenna with a cable that has been constructed to not interfere with the radiation pattern of the antenna. A power (P_{Mea}) is applied to the input of the substitution antenna, and adjust the level of the signal generator output until the value of the receiver reach the previously recorded (P_r). The power of signal source (P_{Mea}) is recorded. The test should be performed by rotating the test item and adjusting the receiving antenna polarization.
5. A amplifier should be connected to the Signal Source output port. And the cable should be connect between the Amplifier and the Substitution Antenna. The cable loss (P_{cl}), the Substitution Antenna Gain (G_a) and the Amplifier Gain (P_{Ag}) should be recorded after test. The measurement results are obtained as described below:
$$\text{Power(EIRP)} = P_{Mea} + P_{Ag} - P_{cl} + G_a$$
6. This value is EIRP since the measurement is calibrated using an antenna of known gain (2.15 dBi) and known input power.
7. ERP can be calculated from EIRP by subtracting the gain of the dipole, $ERP = EIRP - 2.15\text{dBi}$.

TEST RESULTS

Radiated Measurement:

Remark:

1. We were tested all RB Configuration refer 3GPP TS136 521 for each Channel Bandwidth of LTE FDD Band 2, LTE FDD Band 4, LTE FDD Band 7; recorded worst case for each Channel Bandwidth of LTE FDD Band 2, LTE FDD Band 4, LTE FDD Band 7.
2. $EIRP = P_{Mea}(\text{dBm}) - P_{cl}(\text{dB}) + P_{Ag}(\text{dB}) + G_a(\text{dBi})$
3. $ERP = EIRP - 2.15\text{dBi}$ as EIRP by subtracting the gain of the dipole.
4. *Margin = Emission Level - Limit*
5. We tested the worst-case records for H and V directions, and only the worst-case records for V direction were recorded in the report.



**LTE FDD Band 2_Channel Bandwidth 1.4MHz_QPSK**

Frequency (MHz)	P _{Mea} (dBm)	P _{cl} (dB)	G _a Antenna Gain(dB)	P _{Aq} (dB)	Burst Average EIRP (dBm)	Limit (dBm)	Margin (dB)	Polarization
1850.7	-19.37	4.03	8.38	35.51	20.49	33.01	-12.52	V
1880.0	-19.88	4.08	8.33	35.56	19.93	33.01	-13.08	V
1909.3	-19.74	4.14	8.26	35.63	20.01	33.01	-13.00	V

LTE FDD Band 2_Channel Bandwidth 3MHz_QPSK

Frequency (MHz)	P _{Mea} (dBm)	P _{cl} (dB)	G _a Antenna Gain(dB)	P _{Aq} (dB)	Burst Average EIRP (dBm)	Limit (dBm)	Margin (dB)	Polarization
1851.5	-19.92	4.03	8.38	35.51	19.94	33.01	-13.07	V
1880.0	-19.69	4.08	8.33	35.56	20.12	33.01	-12.89	V
1908.5	-19.74	4.14	8.26	35.63	20.01	33.01	-13.00	V

LTE FDD Band 2_Channel Bandwidth 5MHz_QPSK

Frequency (MHz)	P _{Mea} (dBm)	P _{cl} (dB)	G _a Antenna Gain(dB)	P _{Aq} (dB)	Burst Average EIRP (dBm)	Limit (dBm)	Margin (dB)	Polarization
1852.5	-20.46	4.03	8.38	35.51	19.40	33.01	-13.61	V
1880.0	-20.60	4.08	8.33	35.56	19.21	33.01	-13.80	V
1907.5	-20.23	4.14	8.26	35.63	19.52	33.01	-13.49	V

LTE FDD Band 2_Channel Bandwidth 10MHz_QPSK

Frequency (MHz)	P _{Mea} (dBm)	P _{cl} (dB)	G _a Antenna Gain(dB)	P _{Aq} (dB)	Burst Average EIRP (dBm)	Limit (dBm)	Margin (dB)	Polarization
1855.0	-20.83	4.03	8.38	35.51	19.03	33.01	-13.98	V
1880.0	-21.25	4.08	8.33	35.56	18.56	33.01	-14.45	V
1905.0	-20.57	4.14	8.26	35.63	19.18	33.01	-13.83	V

LTE FDD Band 2_Channel Bandwidth 15MHz_QPSK

Frequency (MHz)	P _{Mea} (dBm)	P _{cl} (dB)	G _a Antenna Gain(dB)	P _{Aq} (dB)	Burst Average EIRP (dBm)	Limit (dBm)	Margin (dB)	Polarization
1857.5	-21.50	4.03	8.38	35.51	18.36	33.01	-14.65	V
1880.0	-21.06	4.08	8.33	35.56	18.75	33.01	-14.26	V
1902.5	-21.03	4.14	8.26	35.63	18.72	33.01	-14.29	V

LTE FDD Band 2_Channel Bandwidth 20MHz_QPSK

Frequency (MHz)	P _{Mea} (dBm)	P _{cl} (dB)	G _a Antenna Gain(dB)	P _{Aq} (dB)	Burst Average EIRP (dBm)	Limit (dBm)	Margin (dB)	Polarization
1860.0	-21.64	4.03	8.38	35.51	18.22	33.01	-14.79	V
1880.0	-22.48	4.08	8.33	35.56	17.33	33.01	-15.68	V
1900.0	-22.46	4.14	8.26	35.63	17.29	33.01	-15.72	V



Shenzhen LCS Compliance Testing Laboratory Ltd.

Add: 101, 201 Bldg A & 301 Bldg C, Juji Industrial Park Yabianxueziwei, Shajing Street, Baoan District, Shenzhen, 518000, China

Tel: +(86) 0755-82591330 | E-mail: webmaster@lcs-cert.com | Web: www.lcs-cert.com

Scan code to check authenticity

**LTE FDD Band 2_Channel Bandwidth 1.4MHz_16QAM**

Frequency (MHz)	P _{Mea} (dBm)	P _{cl} (dB)	G _a Antenna Gain(dB)	P _{Aq} (dB)	Burst Average EIRP (dBm)	Limit (dBm)	Margin (dB)	Polarization
1850.7	-19.56	4.03	8.38	35.51	20.30	33.01	-12.71	V
1880.0	-19.87	4.08	8.33	35.56	19.94	33.01	-13.07	V
1909.3	-20.28	4.14	8.26	35.63	19.47	33.01	-13.54	V

LTE FDD Band 2_Channel Bandwidth 3MHz_16QAM

Frequency (MHz)	P _{Mea} (dBm)	P _{cl} (dB)	G _a Antenna Gain(dB)	P _{Aq} (dB)	Burst Average EIRP (dBm)	Limit (dBm)	Margin (dB)	Polarization
1851.5	-20.68	4.03	8.38	35.51	19.18	33.01	-13.83	V
1880.0	-20.96	4.08	8.33	35.56	18.85	33.01	-14.16	V
1908.5	-20.00	4.14	8.26	35.63	19.75	33.01	-13.26	V

LTE FDD Band 2_Channel Bandwidth 5MHz_16QAM

Frequency (MHz)	P _{Mea} (dBm)	P _{cl} (dB)	G _a Antenna Gain(dB)	P _{Aq} (dB)	Burst Average EIRP (dBm)	Limit (dBm)	Margin (dB)	Polarization
1852.5	-20.56	4.03	8.38	35.51	19.30	33.01	-13.71	V
1880.0	-20.56	4.08	8.33	35.56	19.25	33.01	-13.76	V
1907.5	-20.97	4.14	8.26	35.63	18.78	33.01	-14.23	V

LTE FDD Band 2_Channel Bandwidth 10MHz_16QAM

Frequency (MHz)	P _{Mea} (dBm)	P _{cl} (dB)	G _a Antenna Gain(dB)	P _{Aq} (dB)	Burst Average EIRP (dBm)	Limit (dBm)	Margin (dB)	Polarization
1855.0	-21.49	4.03	8.38	35.51	18.37	33.01	-14.64	V
1880.0	-21.43	4.08	8.33	35.56	18.38	33.01	-14.63	V
1905.0	-21.78	4.14	8.26	35.63	17.97	33.01	-15.04	V

LTE FDD Band 2_Channel Bandwidth 15MHz_16QAM

Frequency (MHz)	P _{Mea} (dBm)	P _{cl} (dB)	G _a Antenna Gain(dB)	P _{Aq} (dB)	Burst Average EIRP (dBm)	Limit (dBm)	Margin (dB)	Polarization
1857.5	-21.83	4.03	8.38	35.51	18.03	33.01	-14.98	V
1880.0	-21.95	4.08	8.33	35.56	17.86	33.01	-15.15	V
1902.5	-22.22	4.14	8.26	35.63	17.53	33.01	-15.48	V

LTE FDD Band 2_Channel Bandwidth 20MHz_16QAM

Frequency (MHz)	P _{Mea} (dBm)	P _{cl} (dB)	G _a Antenna Gain(dB)	P _{Aq} (dB)	Burst Average EIRP (dBm)	Limit (dBm)	Margin (dB)	Polarization
1860.0	-22.79	4.03	8.38	35.51	17.07	33.01	-15.94	V
1880.0	-22.05	4.08	8.33	35.56	17.76	33.01	-15.25	V
1900.0	-22.62	4.14	8.26	35.63	17.13	33.01	-15.88	V



Shenzhen LCS Compliance Testing Laboratory Ltd.

Add: 101, 201 Bldg A & 301 Bldg C, Juji Industrial Park Yabianxueziwei, Shajing Street, Baoan District, Shenzhen, 518000, China

Tel: +(86) 0755-82591330 | E-mail: webmaster@lcs-cert.com | Web: www.lcs-cert.com

Scan code to check authenticity

**LTE FDD Band 4_Channel Bandwidth 1.4MHz_QPSK**

Frequency (MHz)	P _{Mea} (dBm)	P _{cl} (dB)	G _a Antenna Gain(dB)	P _{Aq} (dB)	Burst Average EIRP (dBm)	Limit (dBm)	Margin (dB)	Polarization
1710.7	-18.70	3.93	9.05	34.96	21.38	30.00	-8.62	V
1732.5	-18.66	3.93	8.89	35.01	21.31	30.00	-8.69	V
1754.3	-19.34	3.94	8.76	35.08	20.56	30.00	-9.44	V

LTE FDD Band 4_Channel Bandwidth 3MHz_QPSK

Frequency (MHz)	P _{Mea} (dBm)	P _{cl} (dB)	G _a Antenna Gain(dB)	P _{Aq} (dB)	Burst Average EIRP (dBm)	Limit (dBm)	Margin (dB)	Polarization
1711.5	-19.67	3.93	9.05	34.96	20.41	30.00	-9.59	V
1732.5	-19.42	3.93	8.89	35.01	20.55	30.00	-9.45	V
1753.5	-19.07	3.94	8.76	35.08	20.83	30.00	-9.17	V

LTE FDD Band 4_Channel Bandwidth 5MHz_QPSK

Frequency (MHz)	P _{Mea} (dBm)	P _{cl} (dB)	G _a Antenna Gain(dB)	P _{Aq} (dB)	Burst Average EIRP (dBm)	Limit (dBm)	Margin (dB)	Polarization
1712.5	-19.26	3.93	9.05	34.96	20.82	30.00	-9.18	V
1732.5	-18.92	3.93	8.89	35.01	21.05	30.00	-8.95	V
1752.5	-18.77	3.94	8.76	35.08	21.13	30.00	-8.87	V

LTE FDD Band 4_Channel Bandwidth 10MHz_QPSK

Frequency (MHz)	P _{Mea} (dBm)	P _{cl} (dB)	G _a Antenna Gain(dB)	P _{Aq} (dB)	Burst Average EIRP (dBm)	Limit (dBm)	Margin (dB)	Polarization
1715.0	-18.91	3.93	9.05	34.96	21.17	30.00	-8.83	V
1732.5	-19.48	3.93	8.89	35.01	20.49	30.00	-9.51	V
1750.0	-19.60	3.94	8.76	35.08	20.30	30.00	-9.70	V

LTE FDD Band 4_Channel Bandwidth 15MHz_QPSK

Frequency (MHz)	P _{Mea} (dBm)	P _{cl} (dB)	G _a Antenna Gain(dB)	P _{Aq} (dB)	Burst Average EIRP (dBm)	Limit (dBm)	Margin (dB)	Polarization
1717.5	-19.21	3.93	9.05	34.96	20.87	30.00	-9.13	V
1732.5	-19.05	3.93	8.89	35.01	20.92	30.00	-9.08	V
1747.5	-18.56	3.94	8.76	35.08	21.34	30.00	-8.66	V

LTE FDD Band 4_Channel Bandwidth 20MHz_QPSK

Frequency (MHz)	P _{Mea} (dBm)	P _{cl} (dB)	G _a Antenna Gain(dB)	P _{Aq} (dB)	Burst Average EIRP (dBm)	Limit (dBm)	Margin (dB)	Polarization
1720.0	-19.12	3.93	9.05	34.96	20.96	30.00	-9.04	V
1732.5	-19.73	3.93	8.89	35.01	20.24	30.00	-9.76	V
1745.0	-19.33	3.94	8.76	35.08	20.57	30.00	-9.43	V



Shenzhen LCS Compliance Testing Laboratory Ltd.

Add: 101, 201 Bldg A & 301 Bldg C, Juji Industrial Park Yabianxueziwei, Shajing Street, Baoan District, Shenzhen, 518000, China

Tel: +(86) 0755-82591330 | E-mail: webmaster@lcs-cert.com | Web: www.lcs-cert.com

Scan code to check authenticity

**LTE FDD Band 4_Channel Bandwidth 1.4MHz_16QAM**

Frequency (MHz)	P _{Mea} (dBm)	P _{cl} (dB)	G _a Antenna Gain(dB)	P _{Aq} (dB)	Burst Average EIRP (dBm)	Limit (dBm)	Margin (dB)	Polarization
1710.7	-19.66	3.93	9.05	34.96	20.42	30.00	-9.58	V
1732.5	-19.08	3.93	8.89	35.01	20.89	30.00	-9.11	V
1754.3	-19.20	3.94	8.76	35.08	20.70	30.00	-9.30	V

LTE FDD Band 4_Channel Bandwidth 3MHz_16QAM

Frequency (MHz)	P _{Mea} (dBm)	P _{cl} (dB)	G _a Antenna Gain(dB)	P _{Aq} (dB)	Burst Average EIRP (dBm)	Limit (dBm)	Margin (dB)	Polarization
1711.5	-19.03	3.93	9.05	34.96	21.05	30.00	-8.95	V
1732.5	-19.23	3.93	8.89	35.01	20.74	30.00	-9.26	V
1753.5	-18.72	3.94	8.76	35.08	21.18	30.00	-8.82	V

LTE FDD Band 4_Channel Bandwidth 5MHz_16QAM

Frequency (MHz)	P _{Mea} (dBm)	P _{cl} (dB)	G _a Antenna Gain(dB)	P _{Aq} (dB)	Burst Average EIRP (dBm)	Limit (dBm)	Margin (dB)	Polarization
1712.5	-19.49	3.93	9.05	34.96	20.59	30.00	-9.41	V
1732.5	-19.10	3.93	8.89	35.01	20.87	30.00	-9.13	V
1752.5	-19.53	3.94	8.76	35.08	20.37	30.00	-9.63	V

LTE FDD Band 4_Channel Bandwidth 10MHz_16QAM

Frequency (MHz)	P _{Mea} (dBm)	P _{cl} (dB)	G _a Antenna Gain(dB)	P _{Aq} (dB)	Burst Average EIRP (dBm)	Limit (dBm)	Margin (dB)	Polarization
1715.0	-19.17	3.93	9.05	34.96	20.91	30.00	-9.09	V
1732.5	-19.33	3.93	8.89	35.01	20.64	30.00	-9.36	V
1750.0	-19.24	3.94	8.76	35.08	20.66	30.00	-9.34	V

LTE FDD Band 4_Channel Bandwidth 15MHz_16QAM

Frequency (MHz)	P _{Mea} (dBm)	P _{cl} (dB)	G _a Antenna Gain(dB)	P _{Aq} (dB)	Burst Average EIRP (dBm)	Limit (dBm)	Margin (dB)	Polarization
1717.5	-19.88	3.93	9.05	34.96	20.20	30.00	-9.80	V
1732.5	-19.39	3.93	8.89	35.01	20.58	30.00	-9.42	V
1747.5	-19.08	3.94	8.76	35.08	20.82	30.00	-9.18	V

LTE FDD Band 4_Channel Bandwidth 20MHz_16QAM

Frequency (MHz)	P _{Mea} (dBm)	P _{cl} (dB)	G _a Antenna Gain(dB)	P _{Aq} (dB)	Burst Average EIRP (dBm)	Limit (dBm)	Margin (dB)	Polarization
1720.0	-19.12	3.93	9.05	34.96	20.96	30.00	-9.04	V
1732.5	-18.64	3.93	8.89	35.01	21.33	30.00	-8.67	V
1745.0	-18.57	3.94	8.76	35.08	21.33	30.00	-8.67	V



Shenzhen LCS Compliance Testing Laboratory Ltd.

Add: 101, 201 Bldg A & 301 Bldg C, Juji Industrial Park Yabianxueziwei, Shajing Street, Baoan District, Shenzhen, 518000, China

Tel: +(86) 0755-82591330 | E-mail: webmaster@lcs-cert.com | Web: www.lcs-cert.com

Scan code to check authenticity

*LTE FDD Band 7_Channel Bandwidth 5MHz_QPSK*

Frequency (MHz)	P _{Mea} (dBm)	P _{cl} (dB)	G _a Antenna Gain(dB)	P _{Aq} (dB)	Peak EIRP (dBm)	Limit (dBm)	Margin (dB)	Polarization
2502.5	-18.09	4.32	6.80	36.14	20.53	33.01	-12.48	V
2535.0	-18.54	4.32	6.61	36.17	19.92	33.01	-13.09	V
2567.5	-18.01	4.33	6.57	36.22	20.45	33.01	-12.56	V

LTE FDD Band 7_Channel Bandwidth 10MHz_QPSK

Frequency (MHz)	P _{Mea} (dBm)	P _{cl} (dB)	G _a Antenna Gain(dB)	P _{Aq} (dB)	Peak EIRP (dBm)	Limit (dBm)	Margin (dB)	Polarization
2505.0	-18.62	4.32	6.80	36.14	20.00	33.01	-13.01	V
2535.0	-18.55	4.32	6.61	36.17	19.91	33.01	-13.10	V
2565.0	-18.18	4.33	6.57	36.22	20.28	33.01	-12.73	V

LTE FDD Band 7_Channel Bandwidth 15MHz_QPSK

Frequency (MHz)	P _{Mea} (dBm)	P _{cl} (dB)	G _a Antenna Gain(dB)	P _{Aq} (dB)	Peak EIRP (dBm)	Limit (dBm)	Margin (dB)	Polarization
2507.5	-18.43	4.32	6.80	36.14	20.19	33.01	-12.82	V
2535.0	-18.42	4.32	6.61	36.17	20.04	33.01	-12.97	V
2562.5	-18.99	4.33	6.57	36.22	19.47	33.01	-13.54	V

LTE FDD Band 7_Channel Bandwidth 20MHz_QPSK

Frequency (MHz)	P _{Mea} (dBm)	P _{cl} (dB)	G _a Antenna Gain(dB)	P _{Aq} (dB)	Peak EIRP (dBm)	Limit (dBm)	Margin (dB)	Polarization
2510.0	-18.69	4.32	6.80	36.14	19.93	33.01	-13.08	V
2535.0	-18.73	4.32	6.61	36.17	19.73	33.01	-13.28	V
2560.0	-18.94	4.33	6.57	36.22	19.52	33.01	-13.49	V



Shenzhen LCS Compliance Testing Laboratory Ltd.

Add: 101, 201 Bldg A & 301 Bldg C, Juji Industrial Park Yabianxueziwei, Shajing Street, Baoan District, Shenzhen, 518000, China

Tel: +(86) 0755-82591330 | E-mail: webmaster@lcs-cert.com | Web: www.lcs-cert.com

Scan code to check authenticity

*LTE FDD Band 7_Channel Bandwidth 5MHz_16QAM*

Frequency (MHz)	P _{Mea} (dBm)	P _{cl} (dB)	G _a Antenna Gain(dB)	P _{Aq} (dB)	Peak EIRP (dBm)	Limit (dBm)	Margin (dB)	Polarization
2502.5	-19.52	4.32	6.80	36.14	19.10	33.01	-13.91	V
2535.0	-19.17	4.32	6.61	36.17	19.29	33.01	-13.72	V
2567.5	-19.00	4.33	6.57	36.22	19.46	33.01	-13.55	V

LTE FDD Band 7_Channel Bandwidth 10MHz_16QAM

Frequency (MHz)	P _{Mea} (dBm)	P _{cl} (dB)	G _a Antenna Gain(dB)	P _{Aq} (dB)	Peak EIRP (dBm)	Limit (dBm)	Margin (dB)	Polarization
2505.0	-18.92	4.32	6.80	36.14	19.70	33.01	-13.31	V
2535.0	-19.53	4.32	6.61	36.17	18.93	33.01	-14.08	V
2565.0	-19.62	4.33	6.57	36.22	18.84	33.01	-14.17	V

LTE FDD Band 7_Channel Bandwidth 15MHz_16QAM

Frequency (MHz)	P _{Mea} (dBm)	P _{cl} (dB)	G _a Antenna Gain(dB)	P _{Aq} (dB)	Peak EIRP (dBm)	Limit (dBm)	Margin (dB)	Polarization
2507.5	-19.60	4.32	6.80	36.14	19.02	33.01	-13.99	V
2535.0	-19.14	4.32	6.61	36.17	19.32	33.01	-13.69	V
2562.5	-19.58	4.33	6.57	36.22	18.88	33.01	-14.13	V

LTE FDD Band 7_Channel Bandwidth 20MHz_16QAM

Frequency (MHz)	P _{Mea} (dBm)	P _{cl} (dB)	G _a Antenna Gain(dB)	P _{Aq} (dB)	Peak EIRP (dBm)	Limit (dBm)	Margin (dB)	Polarization
2510.0	-19.01	4.32	6.80	36.14	19.61	33.01	-13.40	V
2535.0	-19.04	4.32	6.61	36.17	19.42	33.01	-13.59	V
2560.0	-18.96	4.33	6.57	36.22	19.50	33.01	-13.51	V



Shenzhen LCS Compliance Testing Laboratory Ltd.

Add: 101, 201 Bldg A & 301 Bldg C, Juji Industrial Park Yabianxueziwei, Shajing Street, Baoan District, Shenzhen, 518000, China

Tel: +(86) 0755-82591330 | E-mail: webmaster@lcs-cert.com | Web: www.lcs-cert.com

Scan code to check authenticity



4.2 Peak-to-Average Ratio (PAR)

LIMIT

The Peak-to-Average Ratio (PAR) of the transmission may not exceed 13 dB.

TEST CONFIGURATION

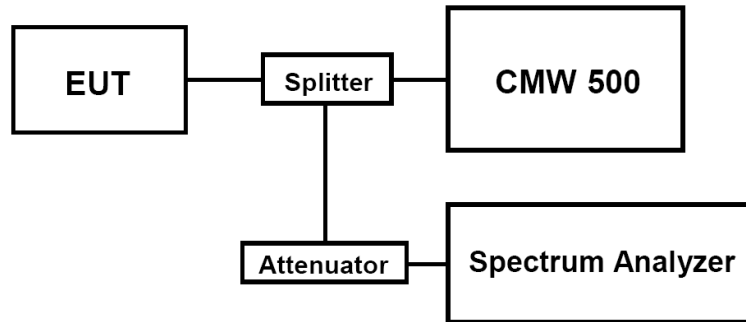

TEST PROCEDURE

1. Refer to instrument's analyzer instruction manual for details on how to use the power statistics/CCDF function;
2. Set resolution/measurement bandwidth \geq signal's occupied bandwidth;
3. Set the number of counts to a value that stabilizes the measured CCDF curve;
4. Set the measurement interval as follows:
 - 1). for continuous transmissions, set to 1 ms,
 - 2). for burst transmissions, employ an external trigger that is synchronized with the EUT burst timing sequence, or use the internal burst trigger with a trigger level that allows the burst to stabilize and set the measurement interval to a time that is less than or equal to the burst duration.
5. Record the maximum PAPR level associated with a probability of 0.1%.

TEST RESULTS

Remark:

1. We were tested all RB Configuration refer 3GPP TS136 521 for each Channel Bandwidth of LTE FDD Band 2, LTE FDD Band 4, LTE FDD Band 7; recorded worst case for each Channel Bandwidth of LTE FDD Band 2, LTE FDD Band 4, LTE FDD Band 7.
2. For E-UTRA Band 2, please refer to Appendix D: Section D.2
3. For E-UTRA Band 4, please refer to Appendix E: Section E.2
4. For E-UTRA Band 7, please refer to Appendix F: Section F.2



Shenzhen LCS Compliance Testing Laboratory Ltd.

Add: 101, 201 Bldg A & 301 Bldg C, Juji Industrial Park Yabianxueziwei, Shajing Street, Baoan District, Shenzhen, 518000, China

Tel: +(86) 0755-82591330 | E-mail: webmaster@lcs-cert.com | Web: www.lcs-cert.com

Scan code to check authenticity



4.3 Occupied Bandwidth and Emission Bandwidth

LIMIT

N/A

TEST CONFIGURATION

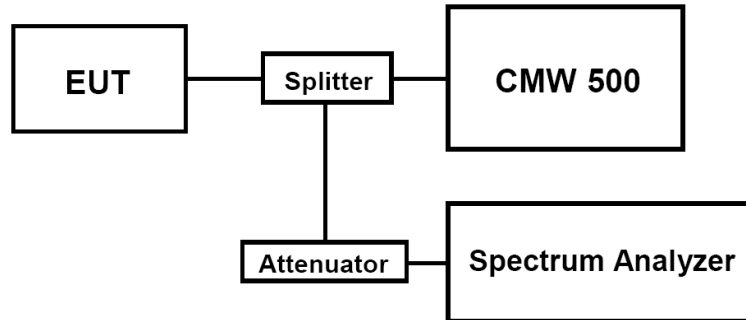

TEST PROCEDURE

The transmitter output was connected to a calibrated coaxial cable and coupler, the other end of which was connected to a spectrum analyzer. The occupied bandwidth was measured with the spectrum analyzer at low, middle and high channel in each band. The -26dBc Emission bandwidth was also measured and recorded. Set RBW was set to about 1% of emission BW, VBW \geq 3 times RBW. -26dBc display line was placed on the screen (or 99% bandwidth), the occupied bandwidth is the delta frequency between the two points where the display line intersects the signal trace.

TEST RESULTS

Remark:

1. We were tested all RB Configuration refer 3GPP TS136 521 for each Channel Bandwidth of LTE FDD Band 2, LTE FDD Band 4, LTE FDD Band 7; recorded worst case for each Channel Bandwidth of LTE FDD Band 2, LTE FDD Band 4, LTE FDD Band 7.
2. For E-UTRA Band 2, please refer to Appendix D: Section D.3
3. For E-UTRA Band 4, please refer to Appendix E: Section E.3
4. For E-UTRA Band 7, please refer to Appendix F: Section F.3



Shenzhen LCS Compliance Testing Laboratory Ltd.

Add: 101, 201 Bldg A & 301 Bldg C, Juji Industrial Park Yabianxueziwei, Shajing Street, Baoan District, Shenzhen, 518000, China

Tel: +(86) 0755-82591330 | E-mail: webmaster@lcs-cert.com | Web: www.lcs-cert.com

Scan code to check authenticity



4.4 Band Edge compliance

LIMIT

For LTE FDD Band 2: Per FCC §24.238 the power of any emission outside of the authorized operating frequency ranges must be attenuated below the transmitting power (P) by a factor of at least $43 + 10\log(P)$ dB.

For LTE FDD Band 4: Per §27.53(h): For operations in the 1710–1755 MHz and 2110–2155 MHz bands, the power of any emission outside a licensee's frequency block shall be attenuated below the transmitter power (P) by at least $43 + 10 \log_{10}(P)$ dB.

For LTE FDD Band 7: Per FCC §27.53 (m)(4): For mobile digital stations, the attenuation factor shall be not less than:

- $40 + 10\log P$ dB (–10 dBm, 100 nW) on all frequencies between the channel edge and 5 MHz from the channel edge,
- $43 + 10\log P$ dB (–13 dBm, 50 nW) on all frequencies between 5 MHz and X MHz from the channel edge, and
- $55 + 10\log P$ dB (–25 dBm, 3 nW) on all frequencies more than X MHz from the channel edge, where X is the greater of 6 MHz or the actual emission bandwidth (26 dB). [§ 27.53(m)(4)]

In addition, the attenuation factor (fixed limit) shall not be less than:

- $43 + 10\log P$ dB on all frequencies between 2490.5 MHz and 2496 MHz, and
- $55 + 10\log P$ dB at or below 2490.5 MHz. [§ 27.53(m)(4)]

TEST CONFIGURATION

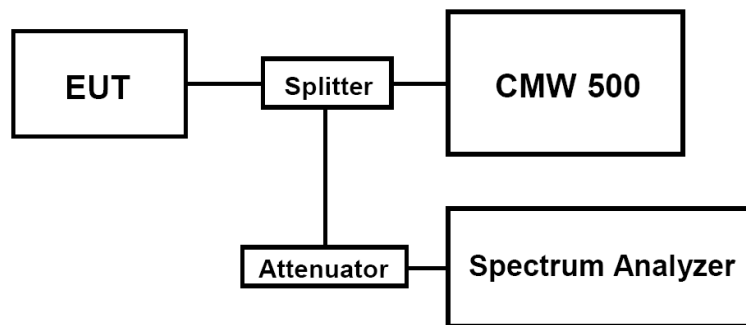

TEST PROCEDURE

1. The transmitter output port was connected to base station.
2. The RF output of EUT was connected to the power meter by RF cable and attenuator, the path loss was compensated to the results for each measurement.
3. Set EUT at maximum power through base station.
4. Select lowest and highest channels for each band and different modulation.
5. Measure Band edge using RMS (Average) detector by spectrum

TEST RESULTS

Remark:

1. We were tested all RB Configuration refer 3GPP TS136 521 for each Channel Bandwidth of LTE FDD Band 2, LTE FDD Band 4, LTE FDD Band 7; recorded worst case for each Channel Bandwidth of LTE FDD Band 2, LTE FDD Band 4, LTE FDD Band 7.
2. For E-UTRA Band 2, please refer to Appendix D: Section D.4
3. For E-UTRA Band 4, please refer to Appendix E: Section E.4
4. For E-UTRA Band 7, please refer to Appendix F: Section F.4





4.5 Spurious Emission on Antenna Port

LIMIT

For LTE FDD Band 2: Per FCC §24.238 the power of any emission outside of the authorized operating frequency ranges must be attenuated below the transmitting power (P) by a factor of at least $43 + 10\log(P)$ dB.

For LTE FDD Band 4: Per §27.53(h): For operations in the 1710–1755 MHz and 2110–2155 MHz bands, the power of any emission outside a licensee's frequency block shall be attenuated below the transmitter power (P) by at least $43 + 10 \log_{10}(P)$ dB.

For LTE FDD Band 7: Per FCC §27.53 (m)(4): For mobile digital stations, the attenuation factor shall be not less than:

- $40 + 10\log P$ dB (–10 dBm, 100 nW) on all frequencies between the channel edge and 5 MHz from the channel edge,
- $43 + 10\log P$ dB (–13 dBm, 50 nW) on all frequencies between 5 MHz and X MHz from the channel edge, and
- $55 + 10\log P$ dB (–25 dBm, 3 nW) on all frequencies more than X MHz from the channel edge, where X is the greater of 6 MHz or the actual emission bandwidth (26 dB). [§ 27.53(m)(4)]

In addition, the attenuation factor (fixed limit) shall not be less than:

- $43 + 10\log P$ dB on all frequencies between 2490.5 MHz and 2496 MHz, and
- $55 + 10\log P$ dB at or below 2490.5 MHz. [§ 27.53(m)(4)]

TEST CONFIGURATION

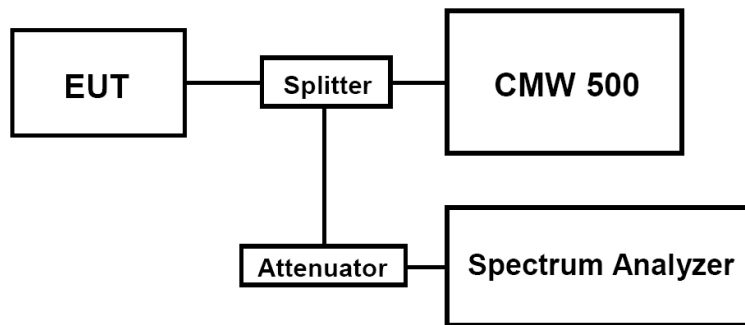

TEST PROCEDURE

The EUT was setup according to TIA-603-E

- a. Place the EUT on a bench and set it in transmitting mode.
- b. Connect a low loss RF cable from the antenna port to a spectrum analyzer and CMW 500 by a Directional Couple.
- c. EUT Communicate with CMW 500, then select a channel for testing.
- d. Add a correction factor to the display of spectrum, and then test.
- e. The resolution bandwidth of the spectrum analyzer was set sufficient scans were taken to show the out of band Emission if any up to 10th harmonic.
- f. Please refer to following tables for test antenna conducted emissions.





Working Frequency	Sub range (GHz)	RBW	VBW	Sweep time (s)
LTE FDD Band 2	0.000009~0.000015	1KHz	3KHz	Auto
	0.000015~0.03	10KHz	30KHz	Auto
	0.03~26	1 MHz	3 MHz	Auto
LTE FDD Band 4	0.000009~0.000015	1KHz	3KHz	Auto
	0.000015~0.03	10KHz	30KHz	Auto
	0.03~26	1 MHz	3 MHz	Auto
LTE FDD Band 7	0.000009~0.000015	1KHz	3KHz	Auto
	0.000015~0.03	10KHz	30KHz	Auto
	0.03~26	1 MHz	3 MHz	Auto

TEST RESULTS

Remark:

1. We were tested all RB Configuration refer 3GPP TS136 521 for each Channel Bandwidth of LTE FDD Band 2, LTE FDD Band 4, LTE FDD Band 7; recorded worst case for each Channel Bandwidth of LTE FDD Band 2, LTE FDD Band 4, LTE FDD Band 7.
2. For E-UTRA Band 2, please refer to Appendix D: Section D.5
3. For E-UTRA Band 4, please refer to Appendix E: Section E.5
4. For E-UTRA Band 7, please refer to Appendix F: Section F.5



Shenzhen LCS Compliance Testing Laboratory Ltd.

Add: 101, 201 Bldg A & 301 Bldg C, Juji Industrial Park Yabianxueziwei, Shajing Street, Baoan District, Shenzhen, 518000, China

Tel: +(86) 0755-82591330 | E-mail: webmaster@lcs-cert.com | Web: www.lcs-cert.com

Scan code to check authenticity

4.6 Radiated Spurious Emission

LIMIT

For LTE FDD Band 2: Per FCC §24.238 the power of any emission outside of the authorized operating frequency ranges must be attenuated below the transmitting power (P) by a factor of at least $43 + 10\log(P)$ dB.

For LTE FDD Band 4: Per §27.53(h): For operations in the 1710–1755 MHz and 2110–2155 MHz bands, the power of any emission outside a licensee's frequency block shall be attenuated below the transmitter power (P) by at least $43 + 10 \log_{10}(P)$ dB.

For LTE FDD Band 7: Per FCC §27.53 (m)(4): For mobile digital stations, the attenuation factor shall be not less than:

- $40 + 10\log P$ dB (–10 dBm, 100 nW) on all frequencies between the channel edge and 5 MHz from the channel edge,
- $43 + 10\log P$ dB (–13 dBm, 50 nW) on all frequencies between 5 MHz and X MHz from the channel edge, and
- $55 + 10\log P$ dB (–25 dBm, 3 nW) on all frequencies more than X MHz from the channel edge, where X is the greater of 6 MHz or the actual emission bandwidth (26 dB). [§ 27.53(m)(4)]

In addition, the attenuation factor (fixed limit) shall not be less than:

- $43 + 10\log P$ dB on all frequencies between 2490.5 MHz and 2496 MHz, and
- $55 + 10\log P$ dB at or below 2490.5 MHz. [§ 27.53(m)(4)]

TEST CONFIGURATION

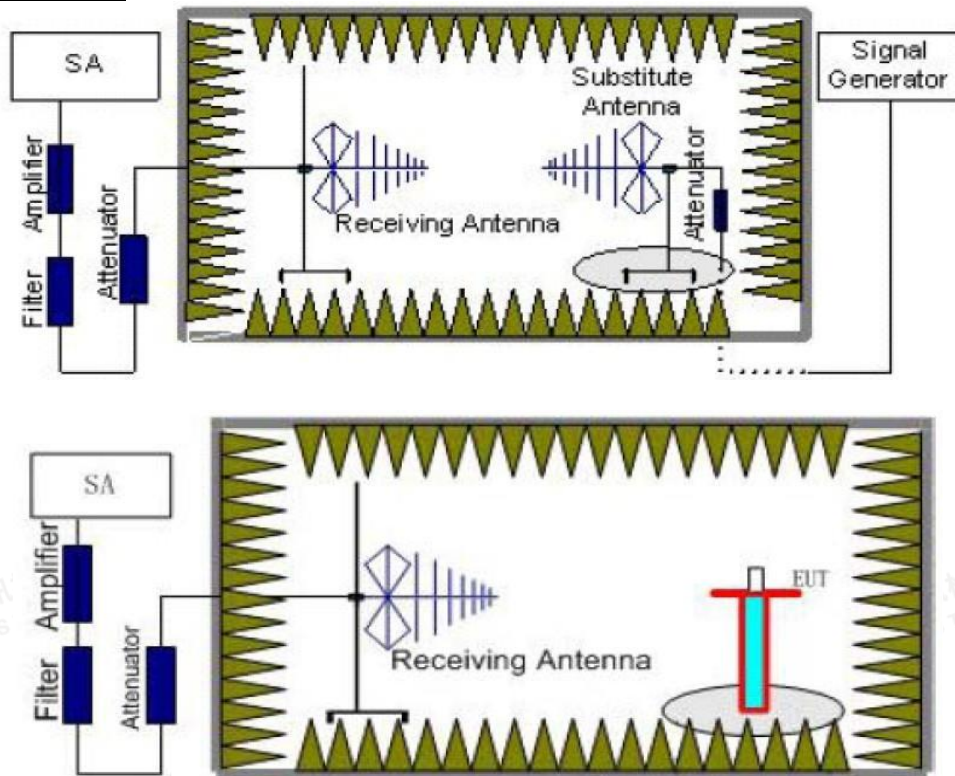



TEST PROCEDURE

1. EUT was placed on a 1.50 meter high non-conductive stand at a 3 meter test distance from the receive antenna. A receiving antenna was placed on the antenna mast 3 meters from the EUT for emission measurements. The height of receiving antenna is 1.50m. Detected emissions were maximized at each frequency by rotating the EUT through 360° and adjusting the receiving antenna polarization. The radiated emission measurements of all transmit frequencies in three channels (High, Middle, Low) were measured with peak detector.
2. A log-periodic antenna or double-ridged waveguide horn antenna shall be substituted in place of the EUT. The log-periodic antenna will be driven by a signal generator and the level will be adjusted till the same power value on the spectrum analyzer or receiver. The level of the spurious emissions can be calculated through the level of the signal generator, cable loss, the gain of the substitution antenna and the reading of the spectrum analyzer or receiver.
3. The EUT is then put into continuously transmitting mode at its maximum power level during the test. Set Test Receiver or Spectrum RBW=1MHz, VBW=3MHz, And the maximum value of the receiver should be recorded as (P_r).
4. The EUT shall be replaced by a substitution antenna. In the chamber, an substitution antenna for the frequency band of interest is placed at the reference point of the chamber. An RF Signal source for the frequency band of interest is connected to the substitution antenna with a cable that has been constructed to not interfere with the radiation pattern of the antenna. A power (P_{Mea}) is applied to the input of the substitution antenna, and adjust the level of the signal generator output until the value of the receiver reach the previously recorded (P_r). The power of signal source (P_{Mea}) is recorded. The test should be performed by rotating the test item and adjusting the receiving antenna polarization.
5. A amplifier should be connected to the Signal Source output port. And the cable should be connect between the Amplifier and the Substitution Antenna. The cable loss (P_{cl}), the Substitution Antenna Gain (G_a) and the Amplifier Gain (P_{Ag}) should be recorded after test.
The measurement results are obtained as described below:
Power(EIRP)=P_{Mea}+ P_{Ag} - P_{cl} + G_a
6. This value is EIRP since the measurement is calibrated using an antenna of known gain (2.15 dBi) and known input power.
7. ERP can be calculated from EIRP by subtracting the gain of the dipole, ERP = EIRP -2.15dBi.
8. In order to make sure test results more clearly, we set frequency range and sweep time for difference frequency range as follows table:

Working Frequency	Subrange (GHz)	RBW	VBW	Sweep time (s)
LTE FDD Band 2	0.00009~0.15	1KHz	3KHz	30
	0.00015~0.03	10KHz	30KHz	10
	0.03~1	100KHz	300KHz	10
	1~2	1 MHz	3 MHz	2
	2~5	1 MHz	3 MHz	3
	5~8	1 MHz	3 MHz	3
	8~11	1 MHz	3 MHz	3
	11~14	1 MHz	3 MHz	3
	14~18	1 MHz	3 MHz	3
LTE FDD Band 4	18~20	1 MHz	3 MHz	2
	0.00009~0.15	1KHz	3KHz	30
	0.00015~0.03	10KHz	30KHz	10
	0.03~1	100KHz	300KHz	10
	1~2	1 MHz	3 MHz	2
	2~5	1 MHz	3 MHz	3
	5~8	1 MHz	3 MHz	3
	8~11	1 MHz	3 MHz	3
	11~14	1 MHz	3 MHz	3
LTE FDD Band 7	14~18	1 MHz	3 MHz	3
	0.00009~0.15	1KHz	3KHz	30
	0.00015~0.03	10KHz	30KHz	10
	0.03~1	100KHz	300KHz	10





	1~2	1 MHz	3 MHz	2
	2~5	1 MHz	3 MHz	3
	5~8	1 MHz	3 MHz	3
	8~11	1 MHz	3 MHz	3
	11~14	1 MHz	3 MHz	3
	14~18	1 MHz	3 MHz	3
	18~20	1 MHz	3 MHz	2
	20~26	1 MHz	3 MHz	2

Frequency	Channel	Frequency Range	Verdict
LTE FDD Band 2	Low	9KHz -20GHz	PASS
	Middle	9KHz -20GHz	PASS
	High	9KHz -20GHz	PASS
LTE FDD Band 4	Low	9KHz -18GHz	PASS
	Middle	9KHz -18GHz	PASS
	High	9KHz -18GHz	PASS
LTE FDD Band 7	Low	9KHz -26GHz	PASS
	Middle	9KHz -26GHz	PASS
	High	9KHz -26GHz	PASS

TEST RESULTS

Remark:

1. We were tested all RB Configuration refer 3GPP TS136 521 for each Channel Bandwidth of LTE FDD Band 2, LTE FDD Band 4, LTE FDD Band 7; recorded worst case for each Channel Bandwidth of LTE FDD Band 2, LTE FDD Band 4, LTE FDD Band 7.
3. We were not recorded other points as values lower than limits.
4. $Power(EIRP) = P_{Mea} + P_{Ag} - P_{cl} + G_a$
5. $Margin = EIRP - Limit$



Shenzhen LCS Compliance Testing Laboratory Ltd.

Add: 101, 201 Bldg A & 301 Bldg C, Juji Industrial Park Yabianxueziwei, Shajing Street, Baoan District, Shenzhen, 518000, China

Tel: +(86) 0755-82591330 | E-mail: webmaster@lcs-cert.com | Web: www.lcs-cert.com

Scan code to check authenticity

*LTE FDD Band 2_Channel Bandwidth 20MHz_QPSK_Low Channel*

Frequency (MHz)	P _{Mea} (dBm)	P _{cl} (dB)	Diatance	G _a Antenna Gain(dB)	Peak EIRP (dBm)	Limit (dBm)	Margin (dB)	Polarization
3715.0	-39.03	5.26	3.00	9.88	-34.41	-13.00	-21.41	H
5572.5	-44.87	6.11	3.00	11.36	-39.62	-13.00	-26.62	H
3715.0	-28.22	5.26	3.00	9.88	-23.60	-13.00	-10.60	V
5572.5	-36.00	6.11	3.00	11.36	-30.75	-13.00	-17.75	V

LTE FDD Band 2_Channel Bandwidth 20MHz_QPSK_Middle Channel

Frequency (MHz)	P _{Mea} (dBm)	P _{cl} (dB)	Diatance	G _a Antenna Gain(dB)	Peak EIRP (dBm)	Limit (dBm)	Margin (dB)	Polarization
3720.0	-40.91	5.32	3.00	10.03	-36.20	-13.00	-23.20	H
5580.0	-46.98	6.19	3.00	11.41	-41.76	-13.00	-28.76	H
3720.0	-29.78	5.32	3.00	10.03	-25.07	-13.00	-12.07	V
5580.0	-35.82	6.19	3.00	11.41	-30.60	-13.00	-17.60	V

LTE FDD Band 2_Channel Bandwidth 20MHz_QPSK_High Channel

Frequency (MHz)	P _{Mea} (dBm)	P _{cl} (dB)	Diatance	G _a Antenna Gain(dB)	Peak EIRP (dBm)	Limit (dBm)	Margin (dB)	Polarization
3800.0	-38.50	5.36	3.00	9.62	-34.24	-13.00	-21.24	H
5700.0	-44.41	6.24	3.00	11.46	-39.19	-13.00	-26.19	H
3800.0	-29.19	5.36	3.00	9.62	-24.93	-13.00	-11.93	V
5700.0	-34.08	6.24	3.00	11.46	-28.86	-13.00	-15.86	V

LTE FDD Band 2_Channel Bandwidth 20MHz_16QAM_Low Channel

Frequency (MHz)	P _{Mea} (dBm)	P _{cl} (dB)	Diatance	G _a Antenna Gain(dB)	Peak EIRP (dBm)	Limit (dBm)	Margin (dB)	Polarization
3715.0	-42.27	5.26	3.00	9.88	-37.65	-13.00	-24.65	H
5572.5	-47.44	6.11	3.00	11.36	-42.19	-13.00	-29.19	H
3715.0	-34.89	5.26	3.00	9.88	-30.27	-13.00	-17.27	V
5572.5	-42.00	6.11	3.00	11.36	-36.75	-13.00	-23.75	V

LTE FDD Band 2_Channel Bandwidth 20MHz_16QAM_Middle Channel

Frequency (MHz)	P _{Mea} (dBm)	P _{cl} (dB)	Diatance	G _a Antenna Gain(dB)	Peak EIRP (dBm)	Limit (dBm)	Margin (dB)	Polarization
3720.0	-40.35	5.32	3.00	10.03	-35.64	-13.00	-22.64	H
5580.0	-46.70	6.19	3.00	11.41	-41.48	-13.00	-28.48	H
3720.0	-34.39	5.32	3.00	10.03	-29.68	-13.00	-16.68	V
5580.0	-39.61	6.19	3.00	11.41	-34.39	-13.00	-21.39	V

LTE FDD Band 2_Channel Bandwidth 20MHz_16QAM_High Channel

Frequency (MHz)	P _{Mea} (dBm)	P _{cl} (dB)	Diatance	G _a Antenna Gain(dB)	Peak EIRP (dBm)	Limit (dBm)	Margin (dB)	Polarization
3800.0	-40.48	5.36	3.00	9.62	-36.22	-13.00	-23.22	H
5700.0	-49.02	6.24	3.00	11.46	-43.80	-13.00	-30.80	H
3800.0	-31.92	5.36	3.00	9.62	-27.66	-13.00	-14.66	V
5700.0	-40.37	6.24	3.00	11.46	-35.15	-13.00	-22.15	V



Shenzhen LCS Compliance Testing Laboratory Ltd.

Add: 101, 201 Bldg A & 301 Bldg C, Juji Industrial Park Yabianxueziwei, Shajing Street, Baoan District, Shenzhen, 518000, China

Tel: +(86) 0755-82591330 | E-mail: webmaster@lcs-cert.com | Web: www.lcs-cert.com

Scan code to check authenticity

*LTE FDD Band 4_Channel Bandwidth 20MHz_QPSK_Low Channel*

Frequency (MHz)	P _{Mea} (dBm)	P _{cl} (dB)	Diatance	G _a Antenna Gain(dB)	Peak EIRP (dBm)	Limit (dBm)	Margin (dB)	Polarization
3440.0	-43.42	4.62	3.00	9.81	-38.23	-13.00	-25.23	H
5160.0	-46.33	5.94	3.00	10.86	-41.41	-13.00	-28.41	H
3440.0	-35.43	4.62	3.00	9.81	-30.24	-13.00	-17.24	V
5160.0	-40.40	5.94	3.00	10.86	-35.48	-13.00	-22.48	V

LTE FDD Band 4_Channel Bandwidth 20MHz_QPSK_Middle Channel

Frequency (MHz)	P _{Mea} (dBm)	P _{cl} (dB)	Diatance	G _a Antenna Gain(dB)	Peak EIRP (dBm)	Limit (dBm)	Margin (dB)	Polarization
3465.0	-41.28	4.63	3.00	9.84	-36.07	-13.00	-23.07	H
5197.5	-45.93	5.94	3.00	10.86	-41.01	-13.00	-28.01	H
3465.0	-34.32	4.63	3.00	9.84	-29.11	-13.00	-16.11	V
5197.5	-40.80	5.94	3.00	10.86	-35.88	-13.00	-22.88	V

LTE FDD Band 4_Channel Bandwidth 20MHz_QPSK_High Channel

Frequency (MHz)	P _{Mea} (dBm)	P _{cl} (dB)	Diatance	G _a Antenna Gain(dB)	Peak EIRP (dBm)	Limit (dBm)	Margin (dB)	Polarization
3490.0	-40.40	4.65	3.00	9.90	-35.15	-13.00	-22.15	H
5235.0	-47.65	5.95	3.00	10.91	-42.69	-13.00	-29.69	H
3490.0	-34.18	4.65	3.00	9.90	-28.93	-13.00	-15.93	V
5235.0	-39.01	5.95	3.00	10.91	-34.05	-13.00	-21.05	V

LTE FDD Band 4_Channel Bandwidth 20MHz_16QAM_Low Channel

Frequency (MHz)	P _{Mea} (dBm)	P _{cl} (dB)	Diatance	G _a Antenna Gain(dB)	Peak EIRP (dBm)	Limit (dBm)	Margin (dB)	Polarization
3440.0	-46.34	4.62	3.00	9.81	-41.15	-13.00	-28.15	H
5160.0	-48.69	5.94	3.00	10.86	-43.77	-13.00	-30.77	H
3440.0	-37.21	4.62	3.00	9.81	-32.02	-13.00	-19.02	V
5160.0	-41.52	5.94	3.00	10.86	-36.60	-13.00	-23.60	V

LTE FDD Band 4_Channel Bandwidth 20MHz_16QAM_Middle Channel

Frequency (MHz)	P _{Mea} (dBm)	P _{cl} (dB)	Diatance	G _a Antenna Gain(dB)	Peak EIRP (dBm)	Limit (dBm)	Margin (dB)	Polarization
3465.0	-46.66	4.63	3.00	9.84	-41.45	-13.00	-28.45	H
5197.5	-48.60	5.94	3.00	10.86	-43.68	-13.00	-30.68	H
3465.0	-38.23	4.63	3.00	9.84	-33.02	-13.00	-20.02	V
5197.5	-43.62	5.94	3.00	10.86	-38.70	-13.00	-25.70	V

LTE FDD Band 4_Channel Bandwidth 20MHz_16QAM_High Channel

Frequency (MHz)	P _{Mea} (dBm)	P _{cl} (dB)	Diatance	G _a Antenna Gain(dB)	Peak EIRP (dBm)	Limit (dBm)	Margin (dB)	Polarization
3490.0	-45.30	4.65	3.00	9.90	-40.05	-13.00	-27.05	H
5235.0	-50.24	5.95	3.00	10.91	-45.28	-13.00	-32.28	H
3490.0	-39.30	4.65	3.00	9.90	-34.05	-13.00	-21.05	V
5235.0	-42.15	5.95	3.00	10.91	-37.19	-13.00	-24.19	V



Shenzhen LCS Compliance Testing Laboratory Ltd.

Add: 101, 201 Bldg A & 301 Bldg C, Juji Industrial Park Yabianxueziwei, Shajing Street, Baoan District, Shenzhen, 518000, China

Tel: +(86) 0755-82591330 | E-mail: webmaster@lcs-cert.com | Web: www.lcs-cert.com

Scan code to check authenticity

**LTE FDD Band 7_Channel Bandwidth 20MHz_QPSK_Low Channel**

Frequency (MHz)	P _{Mea} (dBm)	P _{cl} (dB)	Diatance	G _a Antenna Gain(dB)	Peak EIRP (dBm)	Limit (dBm)	Margin (dB)	Polarization
5020.0	-39.45	5.88	3.00	10.77	-34.56	-25.00	-9.56	H
7530.0	-45.47	7.12	3.00	12.26	-40.33	-25.00	-15.33	H
5020.0	-33.32	5.88	3.00	10.77	-28.43	-25.00	-3.43	V
7530.0	-36.80	7.12	3.00	12.26	-31.66	-25.00	-6.66	V

LTE FDD Band 7_Channel Bandwidth 20MHz_QPSK_Middle Channel

Frequency (MHz)	P _{Mea} (dBm)	P _{cl} (dB)	Diatance	G _a Antenna Gain(dB)	Peak EIRP (dBm)	Limit (dBm)	Margin (dB)	Polarization
5070.0	-39.30	5.90	3.00	10.81	-34.39	-25.00	-9.39	H
7605.0	-46.06	7.19	3.00	12.32	-40.93	-25.00	-15.93	H
5070.0	-36.04	5.90	3.00	10.81	-31.13	-25.00	-6.13	V
7605.0	-38.04	7.19	3.00	12.32	-32.91	-25.00	-7.91	V

LTE FDD 7_Channel Bandwidth 20MHz_QPSK_High Channel

Frequency (MHz)	P _{Mea} (dBm)	P _{cl} (dB)	Diatance	G _a Antenna Gain(dB)	Peak EIRP (dBm)	Limit (dBm)	Margin (dB)	Polarization
5120.0	-38.12	5.94	3.00	10.86	-33.20	-25.00	-8.20	H
7680.0	-44.73	7.25	3.00	12.98	-39.00	-25.00	-14.00	H
5120.0	-36.65	5.94	3.00	10.86	-31.73	-25.00	-6.73	V
7680.0	-36.84	7.25	3.00	12.98	-31.11	-25.00	-6.11	V

LTE FDD Band 7_Channel Bandwidth 20MHz_16QAM_Low Channel

Frequency (MHz)	P _{Mea} (dBm)	P _{cl} (dB)	Diatance	G _a Antenna Gain(dB)	Peak EIRP (dBm)	Limit (dBm)	Margin (dB)	Polarization
5020.0	-42.22	5.88	3.00	10.77	-37.33	-25.00	-12.33	H
7530.0	-49.27	7.12	3.00	12.26	-44.13	-25.00	-19.13	H
5020.0	-37.49	5.88	3.00	10.77	-32.60	-25.00	-7.60	V
7530.0	-42.93	7.12	3.00	12.26	-37.79	-25.00	-12.79	V

LTE FDD Band 7_Channel Bandwidth 20MHz_16QAM_Middle Channel

Frequency (MHz)	P _{Mea} (dBm)	P _{cl} (dB)	Diatance	G _a Antenna Gain(dB)	Peak EIRP (dBm)	Limit (dBm)	Margin (dB)	Polarization
5070.0	-43.42	5.90	3.00	10.81	-38.51	-25.00	-13.51	H
7605.0	-46.52	7.19	3.00	12.32	-41.39	-25.00	-16.39	H
5070.0	-36.87	5.90	3.00	10.81	-31.96	-25.00	-6.96	V
7605.0	-40.43	7.19	3.00	12.32	-35.30	-25.00	-10.30	V

LTE FDD Band 7_Channel Bandwidth 20MHz_16QAM_High Channel

Frequency (MHz)	P _{Mea} (dBm)	P _{cl} (dB)	Diatance	G _a Antenna Gain(dB)	Peak EIRP (dBm)	Limit (dBm)	Margin (dB)	Polarization
5120.0	-42.92	5.94	3.00	10.86	-38.00	-25.00	-13.00	H
7680.0	-47.27	7.25	3.00	12.98	-41.54	-25.00	-16.54	H
5120.0	-39.72	5.94	3.00	10.86	-34.80	-25.00	-9.80	V
7680.0	-39.88	7.25	3.00	12.98	-34.15	-25.00	-9.15	V

Notes: All channel bandwidth were tested,the report recorded the worst data.



Shenzhen LCS Compliance Testing Laboratory Ltd.

Add: 101, 201 Bldg A & 301 Bldg C, Juji Industrial Park Yabianxueziwei, Shajing Street, Baoan District, Shenzhen, 518000, China

Tel: +(86) 0755-82591330 | E-mail: webmaster@lcs-cert.com | Web: www.lcs-cert.com

Scan code to check authenticity



4.7 Frequency Stability under Temperature & Voltage Variations

LIMIT

According to FCC §2.1055, §22.355, §24.235, §27.54 and §90.213 requirement, the frequency stability shall be sufficient to ensure that the fundamental emissions stay within the authorized bands of operation and should not exceed 2.5ppm.

TEST CONFIGURATION

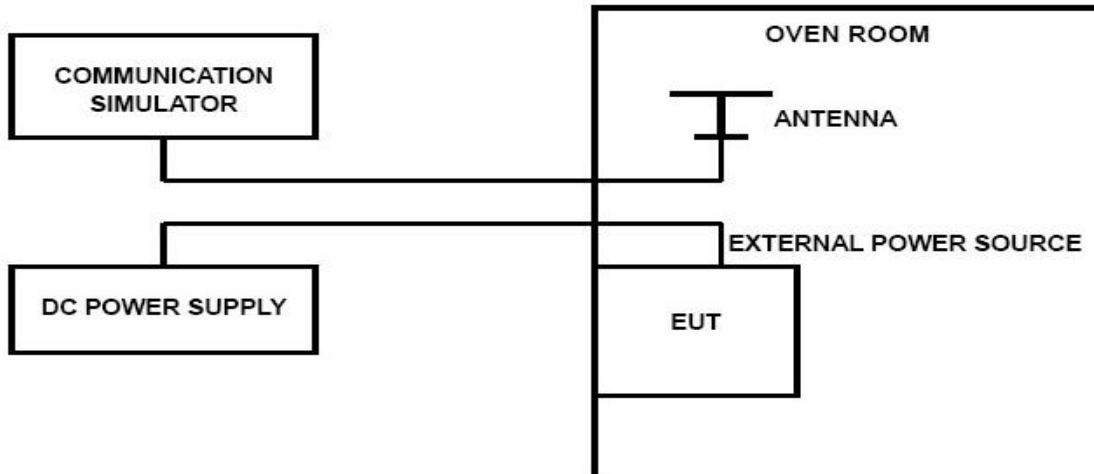

TEST PROCEDURE

The EUT was setup according to TIA-603-E

Frequency Stability Under Temperature Variations:

In order to measure the carrier frequency under the condition of AFC lock, it is necessary to make measurements with the EUT in a “call mode”. This is accomplished with the use of R&S CMW 500 DIGITAL RADIO COMMUNICATION TESTER.

1. Measure the carrier frequency at room temperature.
2. Subject the EUT to overnight soak at -30°C.
3. With the EUT, powered via nominal voltage, connected to the CMW 500 and in a simulated call on middle channel for LTE band 2, LTE band 4, LTE band 7; measure the carrier frequency. These measurements should be made within 2 minutes of Powering up the EUT, to prevent significant self-warming.
4. Repeat the above measurements at 10°C increments from -30°C to +50°C. Allow at least 1.5 hours at each temperature, unpowered, before making measurements.
5. Re-measure carrier frequency at room temperature with nominal voltage. Vary supply voltage from minimum voltage to maximum voltage, in 0.1 Volt increments re-measuring carrier frequency at each voltage. Pause at nominal voltage for 1.5 hours unpowered, to allow any self-heating to stabilize, before continuing.
6. Subject the EUT to overnight soak at +50°C.
7. With the EUT, powered via nominal voltage, connected to the CMW 500 and in a simulated call on the centre channel, measure the carrier frequency. These measurements should be made within 2 minutes of Powering up the EUT, to prevent significant self-warming.
8. Repeat the above measurements at 10 °C increments from +50°C to -30°C. Allow at least 1.5 hours at each temperature, unpowered, before making measurements
9. At all temperature levels hold the temperature to +/- 0.5°C during the measurement procedure.

Frequency Stability Under Voltage Variations:

Set chamber temperature to 20°C. Use a variable AC power supply / DC power source to power the EUT and set the voltage to rated voltage. Set the spectrum analyzer RBW low enough to obtain the desired frequency resolution and recorded the frequency.

Reduce the input voltage to specify extreme voltage variation (±15%) and endpoint, record the maximum frequency change.



**TEST RESULTS****Remark:**

We were tested all RB Configuration refer 3GPP TS136 521 for each Channel Bandwidth of LTE FDD Band 2, LTE FDD Band 4, LTE FDD Band 7; recorded worst case for each Channel Bandwidth of LTE FDD Band 2, LTE FDD Band 4, LTE FDD Band 7.

LTE Band 2, QPSK, 1.4MHz bandwidth (worst case of all bandwidths)

LTE FDD Band 2					
DC Power	Temperature (°C)	Frequency error(Hz)	Frequency error(ppm)	Limit (ppm)	Verdict
VL	20	-9	-0.005	±2.50	PASS
VN	20	-10	-0.005	±2.50	PASS
VH	20	1	0.001	±2.50	PASS
VN	-30	-17	-0.009	±2.50	PASS
VN	-20	-16	-0.009	±2.50	PASS
VN	-10	10	0.005	±2.50	PASS
VN	0	6	0.003	±2.50	PASS
VN	10	-14	-0.007	±2.50	PASS
VN	20	6	0.003	±2.50	PASS
VN	30	5	0.003	±2.50	PASS
VN	40	-10	-0.005	±2.50	PASS
VN	50	0	0.000	±2.50	PASS

LTE Band 2, 16QAM, 1.4MHz bandwidth (worst case of all bandwidths)

LTE FDD Band 2					
DC Power	Temperature (°C)	Frequency error(Hz)	Frequency error(ppm)	Limit (ppm)	Verdict
VL	20	-9	-0.005	±2.50	PASS
VN	20	6	0.003	±2.50	PASS
VH	20	8	0.004	±2.50	PASS
VN	-30	-16	-0.009	±2.50	PASS
VN	-20	1	0.001	±2.50	PASS
VN	-10	-15	-0.008	±2.50	PASS
VN	0	11	0.006	±2.50	PASS
VN	10	0	0.000	±2.50	PASS
VN	20	-7	-0.004	±2.50	PASS
VN	30	9	0.005	±2.50	PASS
VN	40	-11	-0.006	±2.50	PASS
VN	50	-5	-0.003	±2.50	PASS

LTE Band 4, QPSK, 1.4MHz bandwidth (worst case of all bandwidths)

LTE FDD Band 4					
DC Power	Temperature (°C)	Frequency error(Hz)	Frequency error(ppm)	Limit (ppm)	Verdict
VL	20	-47	-0.027	±2.50	PASS
VN	20	19	0.011	±2.50	PASS
VH	20	-4	-0.002	±2.50	PASS
VN	-30	-34	-0.019	±2.50	PASS
VN	-20	-5	-0.003	±2.50	PASS
VN	-10	-24	-0.014	±2.50	PASS
VN	0	-1	-0.001	±2.50	PASS
VN	10	-2	-0.001	±2.50	PASS
VN	20	-27	-0.015	±2.50	PASS
VN	30	-11	-0.006	±2.50	PASS
VN	40	-30	-0.017	±2.50	PASS
VN	50	-15	-0.009	±2.50	PASS



Shenzhen LCS Compliance Testing Laboratory Ltd.

Add: 101, 201 Bldg A & 301 Bldg C, Juji Industrial Park Yabianxueziwei, Shajing Street, Baoan District, Shenzhen, 518000, China

Tel: +(86) 0755-82591330 | E-mail: webmaster@lcs-cert.com | Web: www.lcs-cert.com

Scan code to check authenticity

*LTE Band 4, 16QAM, 1.4MHz bandwidth (worst case of all bandwidths)*

LTE FDD Band 4					
DC Power	Temperature (°C)	Frequency error(Hz)	Frequency error(ppm)	Limit (ppm)	Verdict
VL	20	-36	-0.021	±2.50	PASS
VN	20	-15	-0.009	±2.50	PASS
VH	20	-23	-0.013	±2.50	PASS
VN	-30	10	0.006	±2.50	PASS
VN	-20	-16	-0.009	±2.50	PASS
VN	-10	-44	-0.025	±2.50	PASS
VN	0	-18	-0.010	±2.50	PASS
VN	10	34	0.019	±2.50	PASS
VN	20	-3	-0.002	±2.50	PASS
VN	30	23	0.013	±2.50	PASS
VN	40	31	0.018	±2.50	PASS
VN	50	2	0.001	±2.50	PASS

LTE Band 7, QPSK, 5MHz bandwidth (worst case of all bandwidths and modulation type)

LTE FDD Band 7					
DC Power	Temperature (°C)	Frequency error(Hz)	Frequency error(ppm)	Limit (ppm)	Verdict
VL	20	-12	-0.005	±2.50	PASS
VN	20	20	0.008	±2.50	PASS
VH	20	-5	-0.002	±2.50	PASS
VN	-30	-6	-0.002	±2.50	PASS
VN	-20	13	0.005	±2.50	PASS
VN	-10	13	0.005	±2.50	PASS
VN	0	13	0.005	±2.50	PASS
VN	10	-9	-0.004	±2.50	PASS
VN	20	8	0.003	±2.50	PASS
VN	30	7	0.003	±2.50	PASS
VN	40	-6	-0.002	±2.50	PASS
VN	50	17	0.007	±2.50	PASS

LTE Band 7, 16QAM, 5MHz bandwidth (worst case of all bandwidths and modulation type)

LTE FDD Band 7					
DC Power	Temperature (°C)	Frequency error(Hz)	Frequency error(ppm)	Limit (ppm)	Verdict
VL	20	11	0.004	±2.50	PASS
VN	20	9	0.004	±2.50	PASS
VH	20	-4	-0.002	±2.50	PASS
VN	-30	-4	-0.002	±2.50	PASS
VN	-20	10	0.004	±2.50	PASS
VN	-10	-11	-0.004	±2.50	PASS
VN	0	-4	-0.002	±2.50	PASS
VN	10	13	0.005	±2.50	PASS
VN	20	14	0.006	±2.50	PASS
VN	30	-12	-0.005	±2.50	PASS
VN	40	14	0.006	±2.50	PASS
VN	50	16	0.006	±2.50	PASS



Shenzhen LCS Compliance Testing Laboratory Ltd.

Add: 101, 201 Bldg A & 301 Bldg C, Juji Industrial Park Yabianxueziwei, Shajing Street, Baoan District, Shenzhen, 518000, China

Tel: +(86) 0755-82591330 | E-mail: webmaster@lcs-cert.com | Web: www.lcs-cert.com

Scan code to check authenticity



5 Test Setup Photos of the EUT

Pleaserefer to separated files for Test Setup Photos of the EUT.

6 External Photos of the EUT

Pleaserefer to separated files for External Photos of the EUT.

7 Internal Photos of the EUT

Pleaserefer to separated files for Internal Photos of the EUT.

*******End of Report*******

