

RFM-CSB-3

EULUM
DESIGN

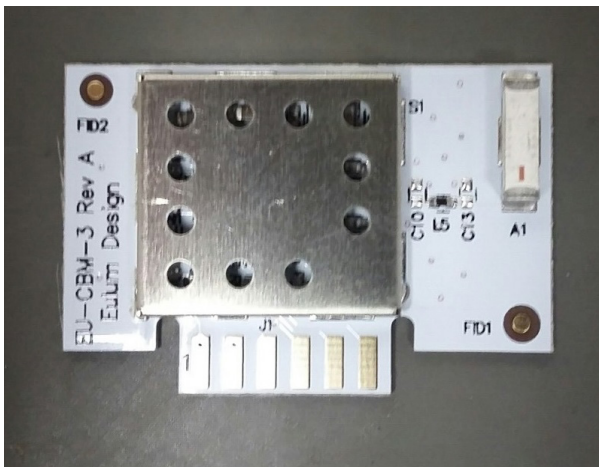

The RFM-CSB-3 module

The RFM-CSB-3 is a class 2 Bluetooth 4.0 module for integration into lighting fixtures, LED drivers or other lighting controls. The module contains a powerful 32 bit ARM® Cortex™ microcontroller and 2.4GHz transceiver with on-board antenna. Four logic level control signals are available on the 6-pin card edge connector. The module operates exclusively through the Casambi app (free on IOS and Android).

Features of the Module include:

- Wireless Bluetooth 4.0 Mesh Network
- Free Casambi lighting control app
- Four programmable control lines
- Easy integration with card-edge SMT connector interface
- FCC & CE certified

The BLE mesh Network

The Bluetooth 4.0 mesh network operates without the need for additional controllers or gateway units. The 200ft (60m) open air functioning distance enables a wide range of lighting arrangements while the exclusive Casambi-Bluetooth connection prevents the lighting system from interfering with other Bluetooth networks.



RFM-CSB-3



TABLE OF CONTENTS

1	<i>Operation</i>	3
2	<i>Block Diagram</i>	3
3	<i>Peripheral Blocks</i>	4
4	<i>Zero Cross Detection</i>	6
5	<i>Specifications</i>	7
6	<i>Dimensions</i>	10
7	<i>Regulatory Statements</i>	11



RFM-CSB-3

1. OPERATION

The RFM-CSB-3 is an embedded wireless module intended to operate in conjunction with the Casambi Lighting control app. Four configurable I/O lines interface to the host device for control of up to 4 independent lighting channels.

A highly integrate SOC (system on chip) contains a 32 bit ARM® Cortex™ microcontroller, 2.4GHz transceiver and several peripheral blocks. These blocks include PWM, SPI, I2C, UART and GPIO (i.e. pushbutton, relay control). These can be configured in Casambi Admin webpages and taken into use without a need to re-program the module.

The default factory configuration for the I/O is four PWM outputs @ 1.2kHz

2. BLOCK DIAGRAM

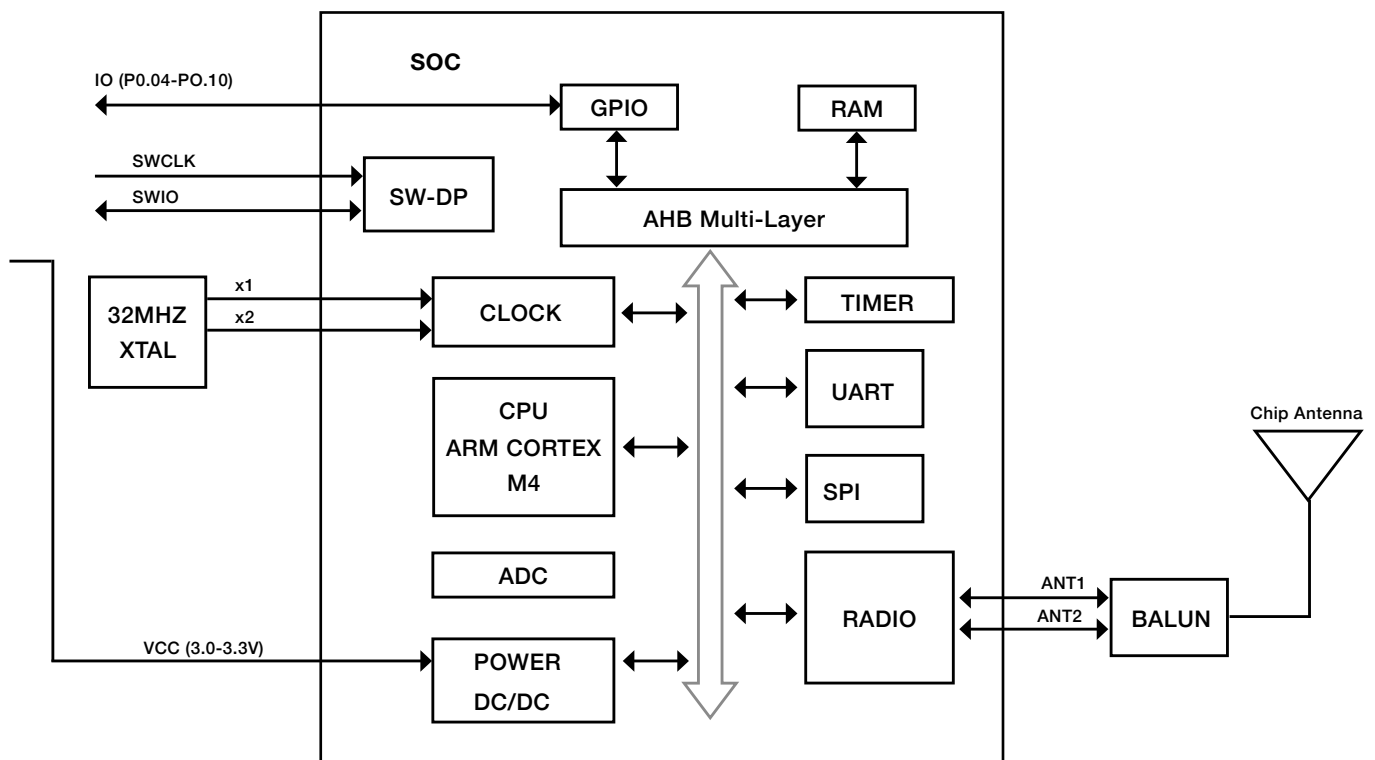

RFM-CSB-3



3. PERIPHERAL BLOCKS

a. PWM

Any GPIO pin can be configured to output a PWM signal. Up to 4 PWM channels can be used simultaneously. PWM frequency can be determined freely up to 40 kHz. By default the PWM frequency is the same for all PWM channels. The maximum resolution is 400-1600 steps and it depends on the PWM frequency. The PWM signal is logic level (max. VCC) and it has driving capacity from 0,5 mA (standard) up to 15 mA (high-drive).

b. SPI

RFM-CSB-3 supports a 3-wire (SCK, MISO, MOSI) bidirectional SPI bus with fast data transfers to and from multiple slaves. RFM-CSB-2 acts as a master and it provides a simple CPU interface which includes a TXD register for sending data and an RXD register for receiving data. These registers are double buffered to enable some degree of uninterrupted data flow in and out of the SPI master.

Each of the slave devices requires an individual chip select signal which can be connected to any available GPIO pin. The SPI master does not implement support for chip select directly. Therefore the correct slave must be selected independently of the SPI master.

The GPIOs used for each SPI interface line can be chosen from any GPIO on the module and are independently configurable. This enables great flexibility in module pinout and enables efficient use of printed circuit board space and signal routing.

The SPI peripheral supports SPI modes 0, 1, 2, and 3.



RFM-CSB-3

c. I2C

This two-wire interface uses clock (SCL) and bidirectional data (SDA). The protocol makes it possible to interconnect up to 128 individually addressable devices. The interface is capable of clock stretching and data rates of 100 kbps and 400 kbps are supported.

The GPIOs used for each Two-Wire Interface line can be chosen from any GPIO on the module and are independently configurable.

d. UART

The Universal Asynchronous Receiver/Transmitter offers fast, full-duplex, asynchronous serial communication with built-in flow control (CTS, RTS) support in HW up to 1 Mbps baud. Parity checking and generation for the 9th data bit are supported.

The GPIOs used for each UART interface line can be chosen from any GPIO on the module and are independently configurable.

e. GPIO

Each of the four I/O can also be configured for alternate input/output functions. Casambi supported functions include:

- Pushbutton input
- Relay control output
- Zero Detect Input
- Fixed “idle” state output

The I/O can be further tailored using options such as:

- Input/output polarity
- Output drive strength
- Internal pull-up and pull-down resistors



RFM-CSB-3



4. ZERO CROSS DETECTION (ZD)

The RFM-CSB-3 can be configured to detect the zero crossing point of an AC signal. This is necessary to take advantage of Casambi's "Smart Switching" feature. This looks for a pattern of on-off cycles (quickly switching AC source on & off) in order to implement specific modes or settings.

For proper Smart Switch operation, local VCC of the module must be kept alive during loss of AC for 1.5 seconds. A 1200uf cap on VCC is typically recommended.

It is the responsibility of the host system designer to create the zero detection circuit and its output needs to be compatible with logic level inputs of the RFM- CSB-1 (see specifications section). ZD polarity and phase are adjustable in the Casambi admin webpages.

If Smart switching is not required, it is suggested to configure the ZD input for online/offline detection. This allows the module to notify the network when it goes offline. This reduces network bandwidth as it will not be repeatedly polling for a device that is no longer responding. Local VCC must be kept alive for at least 500ms to support this feature.

ZERO DETECT CHARACTERISTICS	MIN	TYPICAL	MAX	UNITS
ZERO DETECT FREQUENCY, FMAINS		60		Hz
ZERO DETECT HIGH TIME, TZD_H	1		20	ms
ZERO DETECT LOW TIME, TZD_L	1		20	ms

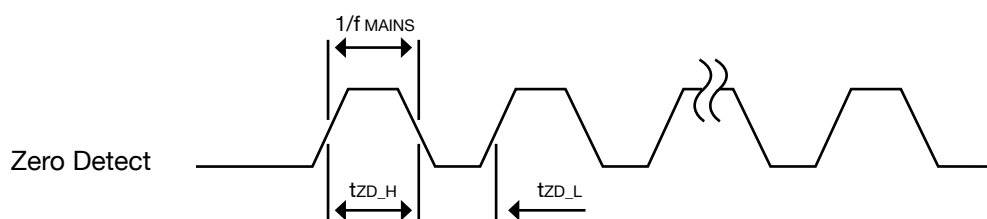

RFM-CSB-3



5. SPECIFICATIONS

MAXIMUM RATINGS	MIN	MAX	UNITS
SUPPLY VOLTAGE, V_{CC}	-0.3	+3.6	V
I/O PIN VOLTAGE	-0.3	$V_{CC} + 0.3$	V
STORAGE TEMPERATURE	-40	+125	°C
OPERATING TEMPERATURE	-25	+70	°C

POWER SUPPLY SPECIFICATIONS	MIN	TYPICAL	MAX	UNITS
SUPPLY VOLTAGE, V_{CC}	+2.5	+3.0	+3.3	V
SUPPLY CURRENT, I_{CC}				
TX/RX ACTIVE		15	21	mA
IDLE		1.5	2	mA

RADIO SPECIFICATIONS	MIN	TYPICAL	MAX	UNITS
OPERATING FREQUENCIES, f_{op} , 1MHz Channel Spacing	2400		2483	MHz
PLL PROGRAMMING RESOLUTION, PLL_{res}		1		MHz
FREQUENCY DEVIATION, ΔBLE	± 225	± 250	± 275	kHz
ON-AIR DATA RATE, bps_{FSK}	250		2000	kbps
MAXIMUM OUTPUT POWER, PRF		4		dBm
SENSITIVITY, $PSENS$	-89		-93	dBm



RFM-CSB-3



GPIO SPECIFICATIONS	MIN	TYPICAL	MAX	UNITS
INPUT HIGH VOLTAGE, VLH	0.7 Vcc		Vcc	V
INPUT LOW VOLTAGE, VIL	0		0.3Vcc	V
OUTPUT HIGH VOLTAGE, VOH	Vcc-0.3		Vcc	V
OUTPUT LOW VOLTAGE, VOL	0		0.3Vcc	V
SOURCE CURRENT, IGPIO_IN		2	14	mA
SINK CURRENT, IGPIO_OUT		2	15	mA
PULL-UP RESISTANCE, RPU	11	13	16	kΩ
PULL DOWN RESISTANCE, RPU	11	13	16	kΩ

*Total source/ sink current of all GPIO pins combined is 15mA. If required source/ sink current for any GPIO pin exceeds 0.5mA, that GPIO pin must be configured for high-drive.

PWM SPECIFICATIONS	MIN	TYPICAL	MAX	UNITS
PWM FREQUENCY, fPWM			40	kHz
PWM RESOLUTION @ fPWM 10kHz			1600	steps
PWM RESOLUTION @ fPWM 20kHz			800	steps
PWM RESOLUTION @ fPWM 40kHz			400	steps



RFM-CSB-3



SPI TIMING PARAMETERS	MIN	TYPICAL	MAX	UNITS
<i>BIT RATES FOR SPI, f_{SPI}</i>	<i>0.125</i>		<i>8</i>	<i>MBPS</i>
<i>DATA TO SCK SETUP, t_{DC}</i>	<i>10</i>			<i>ns</i>
<i>SCK TO DATA HOLD, t_{DH}</i>	<i>10</i>			<i>ns</i>
<i>SCK TO DATA VALID, t_{CD}</i>	<i>60</i>		<i>80</i>	<i>ns</i>
<i>SCK HIGH TIME, t_{CH}</i>	<i>40</i>			<i>ns</i>
<i>SCK LOW TIME, t_{CL}</i>	<i>40</i>			<i>ns</i>
<i>SCK FREQUENCY, f_{SCK}</i>	<i>0.125</i>		<i>8</i>	<i>MHZ</i>
<i>SCK RISE AND FALL TIME, t_R, t_F</i>			<i>100</i>	<i>ns</i>

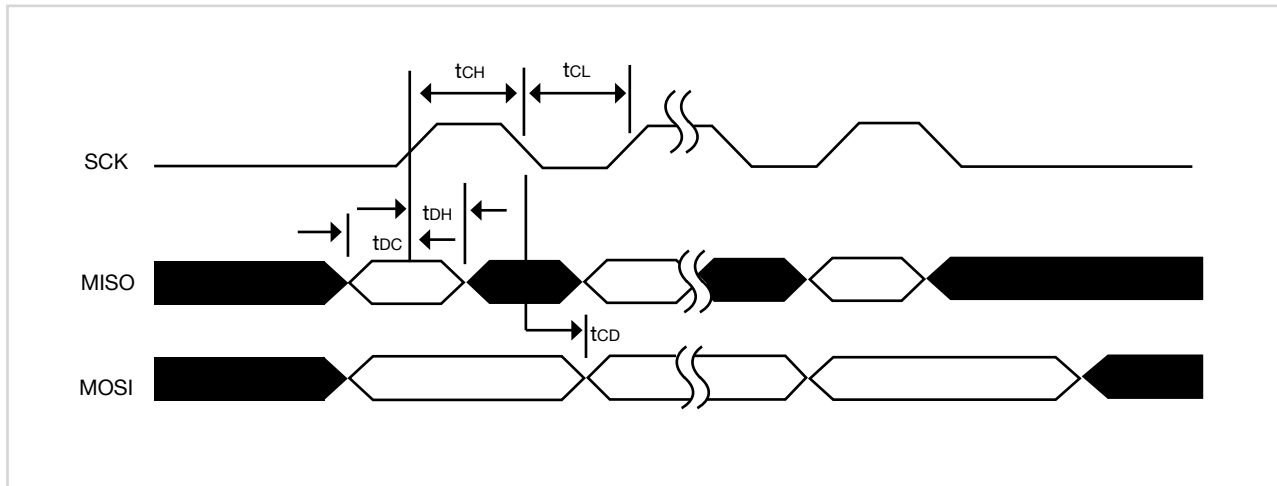

SPI Timing Diagram, One Byte Transmission, SPI Mode 0



RFM-CSB-3



UART SPECIFICATIONS	MIN	TYPICAL	MAX	UNITS
<i>RUN CURRENT @ MAX BAUD RATE</i>		230		μA
<i>RUN CURRENT @ 115200 bps</i>		220		μA
<i>RUN CURRENT @ 1200 bps</i>		210		μA
<i>BAUD RATE FOR UART</i>	1.2		1000	kbps

I2C TIMING PARAMETERS	STANDARD		FAST		UNITS
	MIN	MAX	MIN	MAX	
<i>SCL CLOCK FREQUENCY, fSCL</i>		100		400	kHz
<i>Hold time for START and repeated START condition, tHD_STA</i>	5200		1300		ns
<i>Data setup time before positive edge on SCL, tSU_DAT</i>	300		300		ns
<i>Data hold time after negative edge on SCL, tHD_DAT</i>	300		300		ns
<i>Setup time from SCL goes high to STOP condition, tSU_STO</i>	5200		1300		ns
<i>Bus free time between STOP and START conditions, tBUF</i>	4700		1300		ns

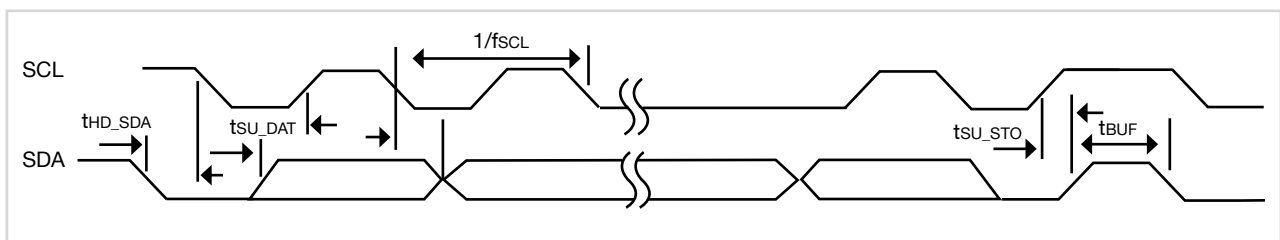

I2C Timing Diagram



RFM-CSB-3

6. DIMENSIONS

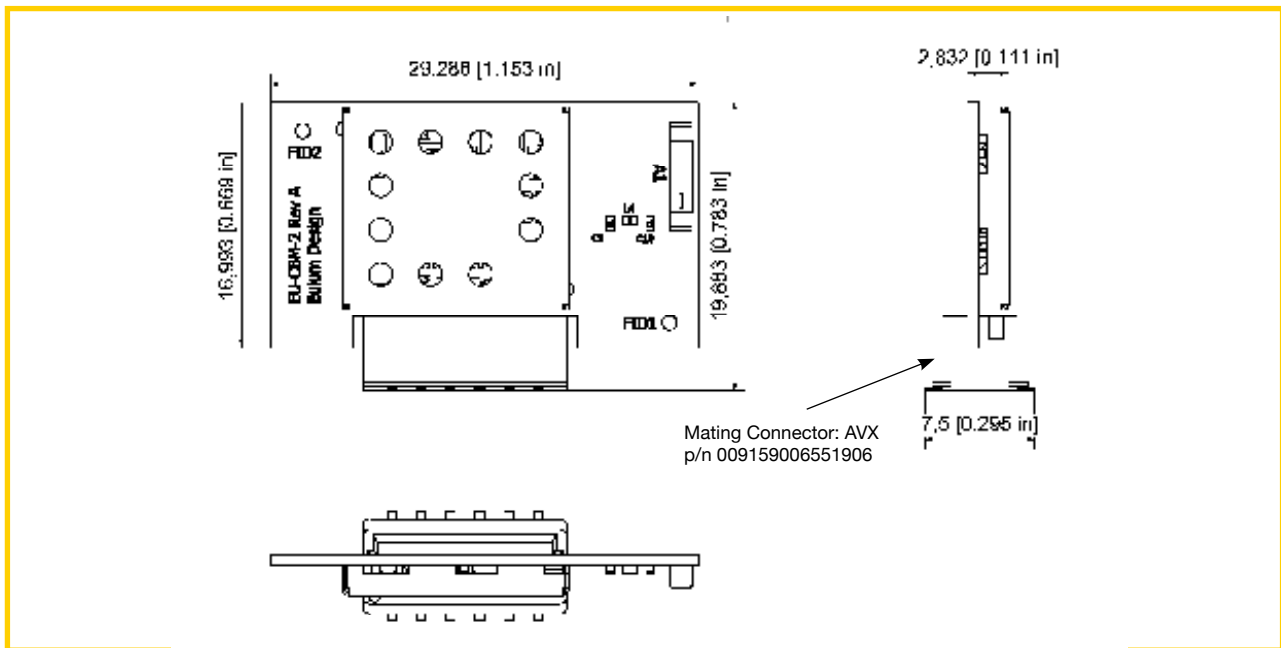

PINOUT		
PIN	LABEL	DESCRIPTION
1	VCC	POWER
2	GND	GROUND
3	P0.05	PWM1*
4	P0.06	PWM2*
5	P0.09	PWM3*
6	P0.10	PWM4*

*Factory Default. GPIO can be configured for alternate input/ output functionality. Please contact Eulum Design for more information.



RFM-CSB-3



7. REGULATORY STATEMENTS

FCC Statement

Changes or modifications not expressly approved by the party responsible for compliance could void the user's authority to operate the equipment.

This device complies with Part 15 of the FCC Rules. Operation is subject to the following two conditions:

- (1) this device may not cause harmful interference, and
- (2) this device must accept any interference received, including interference that may cause undesired operation.

Note:

This equipment has been tested and found to comply with the limits for a Class B digital device, pursuant to Part 15 of the FCC Rules. These limits are designed to provide reasonable protection against harmful interference in a residential installation. This equipment generates, uses, and can radiate radio frequency energy, and if not installed and used in accordance with the instructions, may cause harmful interference to radio communications. However, there is no guarantee that interference will not occur in a particular installation. If this equipment does cause harmful interference to radio or television reception, which can be determined by turning the equipment off and on, the user is encouraged to try to correct the interference by one or more of the following measures:

- Reorient or relocate the receiving antenna.
- Increase the separation between the equipment and receiver.
- Connect the equipment into an outlet on a circuit different from that to which the receiver is connected.
- Consult the dealer or an experienced radio/TV technician for help.



RFM-CSB-3



FCC Important Notes

1. Radiation Exposure Statement

This equipment complies with FCC radiation exposure limits set forth for an uncontrolled environment. This equipment should be installed and operated with a minimum distance of 20cm between the radiator & your body. This transmitter must not be co-located or operating in conjunction with any other antenna or transmitter.

2. OEM Integrated Instructions

This device is intended only for OEM integrators under the following conditions:

- The antenna and transmitter must not be co-located with any other transmitter or antenna. The module shall be only used with the integral antenna(s) that has been originally tested and certified with this module.
- As long as the two (2) conditions above are met, further transmitter testing will not be required. However, the OEM integrator is still responsible for testing their end-product for any additional compliance requirements with this module installed (for example, digital device emission, PC peripheral requirements, etc.)
- In the event that these conditions cannot be met (for example certain laptop configuration or co-location with another transmitter), then the FCC authorization for this module in combination with the host equipment is no longer considered valid and the FCC ID of the module cannot be used on the final product. In these and circumstance, the OEM integrator will be responsible for re-evaluating. The end product (including the transmitter) and obtaining a separate FCC authorization.
- The module is limited to installation in mobile or fixed applications.
- The separate approval is required for all other operating configurations, including portable configurations with respect to Part 2.1093 and different antenna configurations.
- The OEM is still responsible for verifying compliance with FCC Part 15, subpart B limits for unintentional radiators through an accredited test facility.



RFM-CSB-3



3. End Product Labelling

The final end product must be labeled in a visible area with the following:

RFM-CSB-3: "Contains FCC ID: 2AJML- EUCSBM"

Any similar wording that expresses the same meaning may be used.

The FCC Statement below should also be included on the label. When not possible, the FCC Statement should be included in the User Manual of the host device.

"This device complies with part 15 of the FCC rules. Operation is subject to the following two conditions:

- (1) This device may not cause harmful interference.
- (2) This device must accept any interference received, including interference that may cause undesired operation."

4. Information regarding the end user manual

The OEM integrator has to be aware not to provide information to the end user regarding how to install or remove this RF module in the user's manual of the end product which integrates this module. The end user manual shall include all required regulatory information/warning as show in this manual.

CE Regulatory

This device is tested and compliant against the following standards. OEM integrators should consult with qualified test house to verify all regulatory requirements have been met for their complete device.

- EN 62479:2010
- EN60950-1:2006+A11.2009+A1:2010+A12:2011+A2:2013
- ETSI EN 201-489-1 V2.2.0(2017-03)
- ESTI EN 301 489-17 V3.2.0(2017-03)
- ESTI EN 300 328 V2.1.1(2016-11)

