



FCC RADIO TEST REPORT

FCC ID: 2AJK8-UCC1

Product : Smart center

Trade Name : N/A

Model Name : UCC1

Serial Model : UCC12 UCC11 UCC13

Report No. : NTEK-2016NT08238442F1

Prepared for

Shenzhen Lingan Intelligent Technology Co.,Ltd
Baiwang R&D Bldg, Shahe West Road, Nanshan, Shenzhen 518055
P.R.China

Prepared by

NTEK Testing Technology Co., Ltd.

1/F, Building E, Fenda Science Park, Sanwei Community, Xixiang Street
Bao'an District, Shenzhen 518126 P.R. China
Tel.: +86-755-61156588 Fax.: +86-755-61156599
Website: <http://www.ntek.org.cn>

Table of Contents	Page
1 . SUMMARY OF TEST RESULTS	4
1.1 TEST FACILITY	5
1.2 MEASUREMENT UNCERTAINTY	5
2 . GENERAL INFORMATION	6
2.1 GENERAL DESCRIPTION OF EUT	6
2.2 DESCRIPTION OF TEST MODES	8
3 BLOCK SETUP OF EQUIPMENT UNDER TEST	9
3.1 DESCRIPTION OF TEST MODES	9
3.2 DESCRIPTION OF SUPPORT UNITS(CONDUCTED MODE)	10
4 . ANTENNA REQUIREMENT	12
4.1 STANDARD REQUIREMENT	12
4.2 EUT ANTENNA	12
4.3 CONDUCTED EMISSION MEASUREMENT	13
4.3.1 POWER LINE CONDUCTED EMISSION LIMITS	13
4.3.2 TEST PROCEDURE	14
4.3.3 DEVIATION FROM TEST STANDARD	14
4.3.4 TEST SETUP	14
3.2.5 TEST RESULT	15
4.4 RADIATED EMISSION MEASUREMENT	19
4.4.1 RADIATED EMISSION LIMITS	19
4.4.2 TEST PROCEDURE	20
4.4.3 DEVIATION FROM TEST STANDARD	20
4.4.4 TEST SETUP	21
4.4.5 TEST RESULTS (BLOW 30MHZ)	22
4.4.6 TEST RESULTS (BETWEEN 30 – 1000 MHZ)	23
4.4.7 TEST RESULTS (ABOVE 1000 MHZ)	25
4.4.8 TEST RESULTS (RESTRICTED BANDS REQUIREMENTS)	27
5 . BANDWIDTH TEST	29
5.1 TEST PROCEDURE	29
5.2 DEVIATION FROM STANDARD	29
5.3 TEST SETUP	29
5.4 TEST RESULTS	30

1. SUMMARY OF TEST RESULTS

Test procedures according to the technical standards:

FCC Part15, Subpart C (15.249)			
Standard Section	Test Item	Judgment	Remark
15.207	Conducted Emission	Pass	
15.203	Antenna Requirement	Pass	
15.249	Radiated Spurious Emission	Pass	
15.205	Band Edge Emission	Pass	
15.249	Occupied Bandwidth	Pass	

Remark:

1. "N/A" denotes test is not applicable in this Test Report.
2. All test items were verified and recorded according to the standards and without any deviation during the test.

1.1 TEST FACILITY

NTEK Testing Technology Co., Ltd

Add. : 1/F, Building E, Fenda Science Park, Sanwei Community, Xixiang Street, Bao'an District, Shenzhen P.R. China.

FCC FRN Registration No.:238937; IC Registration No.:9270A-1

CNAS Registration No.:L5516

1.2 MEASUREMENT UNCERTAINTY

The reported uncertainty of measurement $y \pm U$, where expanded uncertainty U is based on a standard uncertainty multiplied by a coverage factor of $k=2$, providing a level of confidence of approximately **95 %**.

No.	Item	Uncertainty
1	Conducted Emission Test	$\pm 1.38\text{dB}$
2	RF power,conducted	$\pm 0.16\text{dB}$
3	Spurious emissions,conducted	$\pm 0.21\text{dB}$
4	All emissions,radiated(<1G)	$\pm 4.68\text{dB}$
5	All emissions,radiated(>1G)	$\pm 4.89\text{dB}$
6	Temperature	$\pm 0.5^\circ\text{C}$
7	Humidity	$\pm 2\%$

2. GENERAL INFORMATION

2.1 GENERAL DESCRIPTION OF EUT

Equipment	Smart center
Trade Name	N/A
Model Name	UCC1
Serial Model	UCC12 UCC11 UCC13
Model Difference	All the model are the same circuit and RF module, except the model No..
Product Description	The EUT is a Smart center
	Operation Frequency: 2445 MHz
	Modulation Type: OQPSK
	Antenna Designation: PCB antenna
	Antenna Gain(Peak) 1 dBi
	Based on the application, features, or specification exhibited in User's Manual, the EUT is considered as an ITE/Computing Device. More details of EUT technical specification, please refer to the User's Manual.
Channel List	Please refer to the Note 2.
Adapter	Model: JF005WR-0500100UU Input: 100-240V-50/60Hz 0.18A Output: 5.0V $\overline{\text{---}}$ 1A
Battery	N/A
HW Version:	V001-20160505-001
SW Version:	V1.0

Note:

1. For a more detailed features description, please refer to the manufacturer's specifications or the User's Manual.

2.

Channel	Frequency (MHz)
01	2445

3.

Table for Filed Antenna

Ant	Brand	Model Name	Antenna Type	Connector	Gain (dBi)	NOTE
1	N/A	N/A	PCB Antenna	N/A	1	Antenna

2.2 DESCRIPTION OF TEST MODES

To investigate the maximum EMI emission characteristics generates from EUT, the test system was pre-scanning tested base on the consideration of following EUT operation mode or test configuration mode which possible have effect on EMI emission level. Each of these EUT operation mode(s) or test configuration mode(s) mentioned above was evaluated respectively.

The following summary table is showing all test modes to demonstrate in compliance with the standard.

For AC Conducted Emission	
Mode 2	Link mode

For Radiated Emission	
Final Test Mode	Description
Mode 1	CH 01
Mode 2	Link mode

For Conducted Test Cases	
Final Test Mode	Description
Mode 1	CH 01

Note:

- (1) The measurements are performed at the channel 01.
- (2)The engineering test program was provided and the EUT was programmed to be in continuously transmitting mode. The EUT is use PC test software ZBAuth to set CH1 to continuously transmitting.

3 BLOCK SETUP OF EQUIPMENT UNDER TEST

3.1 DESCRIPTION OF TEST MODES

For AC Conducted Emission Mode

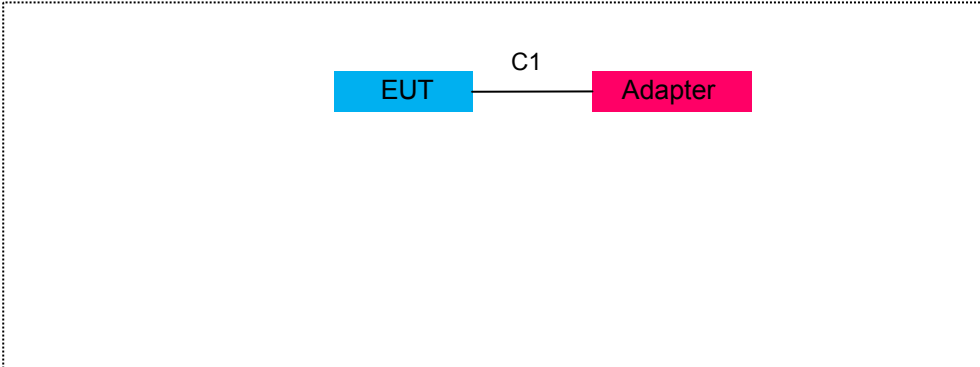

For Radiated Test Cases

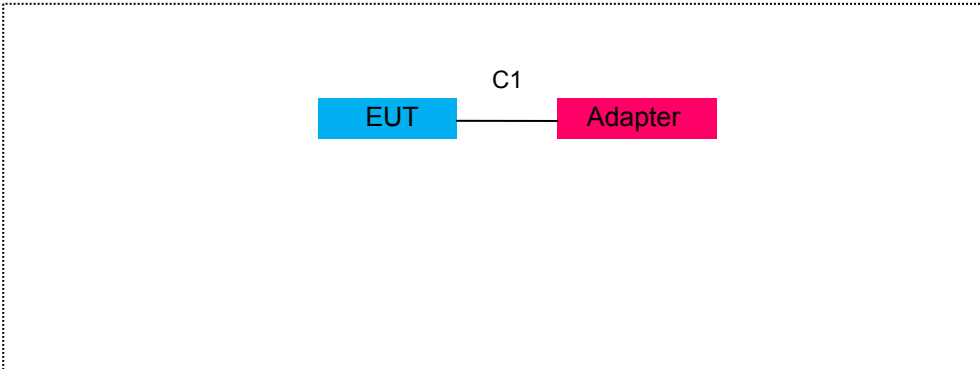

For Conducted Test Cases

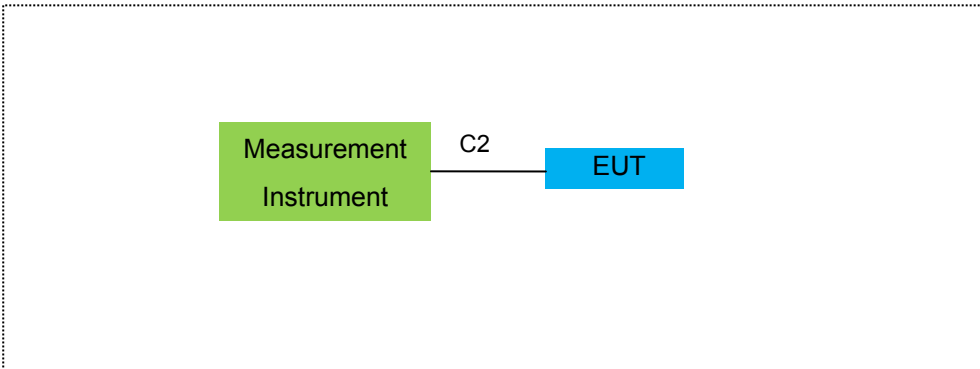

The temporary antenna connector C2 is soldered on the PCB board in order to perform conducted tests and this temporary antenna connector is listed in the SUPPORT equipment list.

3.2 DESCRIPTION OF SUPPORT UNITS(CONDUCTED MODE)

The EUT has been tested as an independent unit together with other necessary accessories or support units. The following support units or accessories were used to form a representative test configuration during the tests.

Item	Equipment	Mfr/Brand	Model/Type No.	Series No.	Note
E-1.	Smart center	N/A	UCC1	2AJK8-UCC1	EUT
E-2	Adapter	N/A	JF005WR-0500100UU	N/A	Peripherals

Item	Shielded Type	Ferrite Core	Length	Note
C-1	Power	NO	NO	1.0m
C-2	RF temporary antenna Cable	NO	NO	0.5m

Note:

- (1) The support equipment was authorized by Declaration of Confirmation.
- (2) For detachable type I/O cable should be specified the length in cm in 『Length』 column.

3.2.1 EQUIPMENTS LIST FOR ALL TEST ITEMS

Radiation Test equipment

Item	Kind of Equipment	Manufacturer	Type No.	Serial No.	Last calibration	Calibrated until	Calibration period
1	Spectrum Analyzer	Agilent	E4440A	MY46186938	2015.11.19	2016.11.18	1 year
2	Test Receiver	R&S	ESPI	101318	2016.06.07	2017.06.06	1 year
3	Bilog Antenna	TESEQ	CBL6111D	31216	2016.07.06	2017.07.05	1 year
4	50Ω Coaxial Switch	Anritsu	MP59B	6200264416	2016.06.07	2017.06.06	1 year
5	Spectrum Analyzer	ADVANTEST	R3132	150900201	2016.06.07	2017.06.06	1 year
6	Horn Antenna	EM	EM-AH-10180	2011071402	2016.07.06	2017.07.05	1 year
7	Horn Ant	Schwarzbeck	BBHA 9170	9170-181	2016.07.06	2017.07.05	1 year
8	Amplifier	EM	EM-30180	060538	2015.12.22	2016.12.21	1 year
9	Loop Antenna	ARA	PLA-1030/B	1029	2016.06.07	2017.06.06	1 year
10	Test Cable	9KHz-2GHz	R-01	N/A	2016.07.06	2017.07.05	1 year
11	Test Cable	800MHz-26GHz	R-02	N/A	2016.07.06	2017.07.05	1 year

Conduction Test equipment

Item	Kind of Equipment	Manufacturer	Type No.	Serial No.	Last calibration	Calibrated until	Calibration period
1	Test Receiver	R&S	ESCI	101160	2016.06.07	2017.06.06	1 year
2	LISN	R&S	ENV216	101313	2016.08.24	2017.08.23	1 year
3	LISN	EMCO	3816/2	00042990	2016.08.24	2017.08.23	1 year
4	50Ω Coaxial Switch	Anritsu	MP59B	6200264417	2016.06.07	2017.06.06	1 year
5	Test Cable	100KHz-50MHz	C01	N/A	2016.06.07	2017.06.06	1 year

Note: Each piece of equipment is scheduled for calibration once a year.

4. ANTENNA REQUIREMENT

4.1 STANDARD REQUIREMENT

15.203 requirement: For intentional device, according to 15.203: an intentional radiator shall be designed to ensure that no antenna other than that furnished by the responsible party shall be used with the device.

4.2 EUT ANTENNA

The EUT antenna is PCB antenna, details to see internal photo, it comply with the standard requirement.

4.3 CONDUCTED EMISSION MEASUREMENT

4.3.1 POWER LINE CONDUCTED EMISSION Limits (Frequency Range 150KHz-30MHz)

Frequency(MHz)	Conducted Emission Limit	
	Quasi-peak	Average
0.15-0.5	66-56*	56-46*
0.5-5.0	56	46
5.0-30.0	60	50

Note: 1. *Decreases with the logarithm of the frequency
 2. The lower limit shall apply at the transition frequencies
 3. The limit decreases in line with the logarithm of the frequency in the range of 0.15 to 0.50MHz.

Note:

- (1) The tighter limit applies at the band edges.
- (2) The limit of " * " marked band means the limitation decreases linearly with the logarithm of the frequency in the range.

The following table is the setting of the receiver

Receiver Parameters	Setting
Attenuation	10 dB
Start Frequency	0.15 MHz
Stop Frequency	30 MHz
IF Bandwidth	9 kHz

4.3.2 TEST PROCEDURE

- a. The EUT was placed 0.4 meters from the horizontal ground plane with EUT being connected to the power mains through a line impedance stabilization network (LISN). All other support equipments powered from additional LISN(s). The LISN provide 50 Ohm/ 50uH of coupling impedance for the measuring instrument.
- b. Interconnecting cables that hang closer than 40 cm to the ground plane shall be folded back and forth in the center forming a bundle 30 to 40 cm long.
- c. I/O cables that are not connected to a peripheral shall be bundled in the center. The end of the cable may be terminated, if required, using the correct terminating impedance. The overall length shall not exceed 1 m.
- d. LISN at least 80 cm from nearest part of EUT chassis.
- e. For the actual test configuration, please refer to the related Item –EUT Test Photos.

4.3.3 DEVIATION FROM TEST STANDARD

No deviation

4.3.4 TEST SETUP

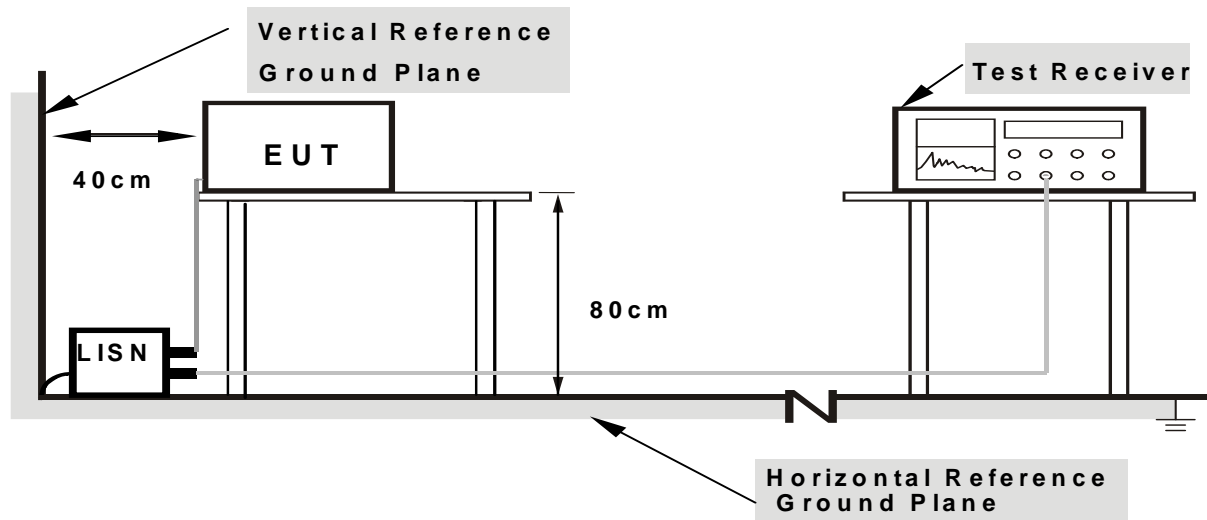

Note: 1. Support units were connected to second LISN.

2. Both of LISNs (AMN) are 80 cm from EUT and at least 80 cm from other units and other metal planes

3.2.5 TEST RESULT

EUT :	Smart center	Model Name :	UCC1
Temperature :	20 °C	Relative Humidity :	48%
Pressure :	1010hPa	Phase :	N/A
Test Voltage :	DC 5V from Adapter AC120V/60Hz	Test Mode :	L

Frequency (MHz)	Meter Reading (dBμV)	Factor (dB)	Emission Level (dBμV/m)	Limits (dBμV/m)	Margin (dB)	Detector Type
0.1539	38.44	10.12	48.56	65.78	-17.22	QP
0.1539	23.16	10.12	33.28	55.78	-22.5	AVG
0.206	34.1	10.13	44.23	63.36	-19.13	QP
0.206	20.3	10.13	30.43	53.36	-22.93	AVG
0.23	32.12	10.13	42.25	62.45	-20.2	QP
0.23	15.66	10.13	25.79	52.45	-26.66	AVG
0.386	25.21	10.05	35.26	58.15	-22.89	QP
0.386	14.44	10.05	24.49	48.15	-23.66	AVG
1.77	25.33	9.79	35.12	56	-20.88	QP
1.77	14.62	9.79	24.41	46	-21.59	AVG
4.9939	25.86	9.83	35.69	56	-20.31	QP
4.9939	13.87	9.83	23.7	46	-22.3	AVG

Remark:

1. Factor = Antenna Factor + Cable Loss – Pre-amplifier.

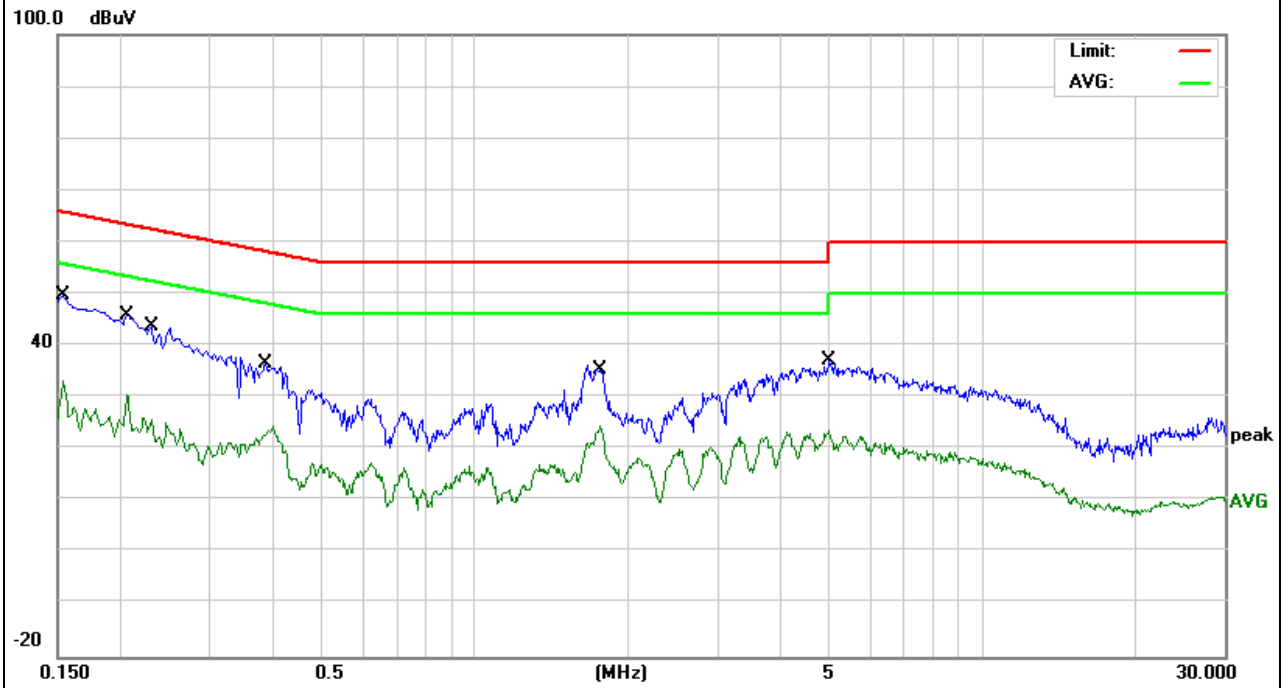

EUT :	Smart center	Model Name :	UCC1
Temperature :	20 °C	Relative Humidity :	48%
Pressure :	1010 hPa	Phase :	N/A
Test Voltage :	DC 5V from Adapter AC120V/60Hz	Test Mode :	N

Frequency (MHz)	Meter Reading (dBμV)	Factor (dB)	Emission Level (dBμV/m)	Limits (dBμV/m)	Margin (dB)	Detector Type
0.1539	39.88	10.08	49.96	65.78	-15.82	QP
0.1539	21.42	10.08	31.5	55.78	-24.28	AVG
0.1819	38.66	10.04	48.7	64.39	-15.69	QP
0.1819	21.09	10.04	31.13	54.39	-23.26	AVG
0.402	31.02	10.06	41.08	57.81	-16.73	QP
0.402	18.62	10.06	28.68	47.81	-19.13	AVG
0.6219	23.54	9.82	33.36	56	-22.64	QP
0.6219	10.9	9.82	20.72	46	-25.28	AVG
1.074	21.61	9.88	31.49	56	-24.51	QP
1.074	8.48	9.88	18.36	46	-27.64	AVG
1.75	22.7	9.81	32.51	56	-23.49	QP
1.75	13.29	9.81	23.1	46	-22.9	AVG

Remark:

1. Factor = Antenna Factor + Cable Loss – Pre-amplifier.

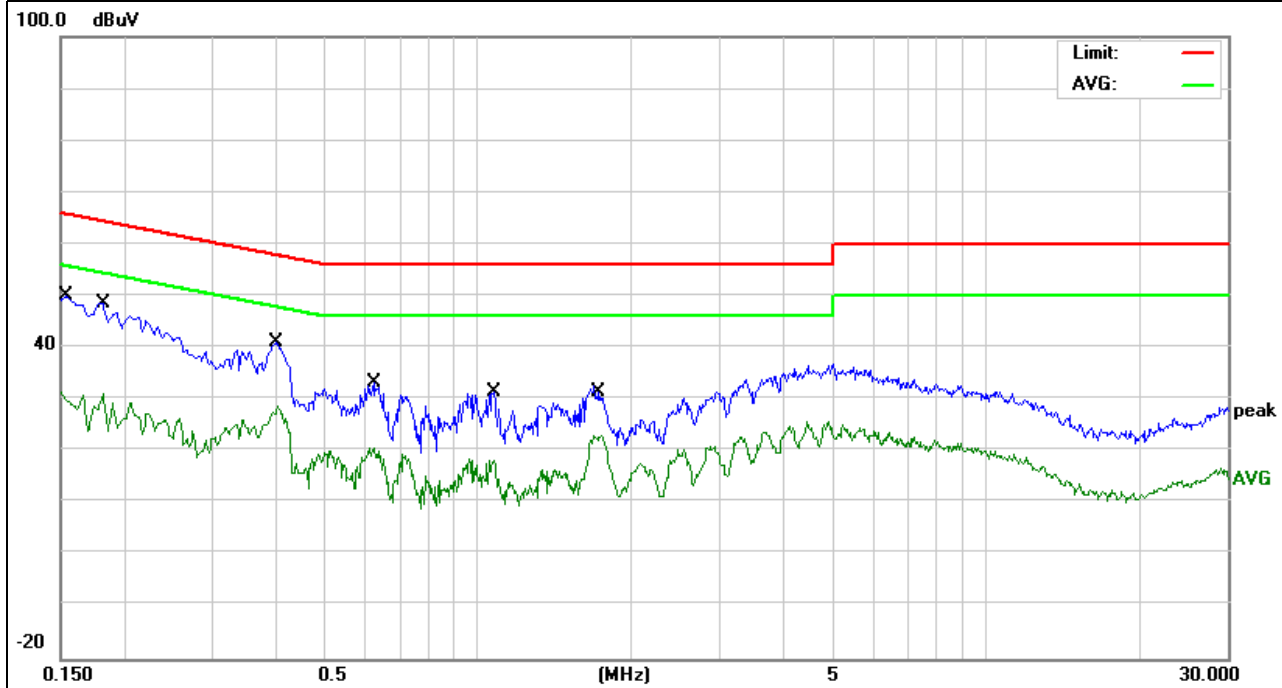

EUT :	Smart center	Model Name :	UCC1
Temperature :	20 °C	Relative Humidity :	48%
Pressure :	1010hPa	Phase :	N/A
Test Voltage :	DC 5V from Adapter AC240V/60Hz	Test Mode :	L

Frequency (MHz)	Meter Reading (dBμV)	Factor (dB)	Emission Level (dBμV/m)	Limits (dBμV/m)	Margin (dB)	Detector Type
0.158	32.14	10.12	42.26	65.56	-23.3	QP
0.159	14.4	10.12	24.52	55.51	-30.99	AVG
0.186	31.1	10.13	41.23	64.21	-22.98	QP
0.186	12.81	10.13	22.94	54.21	-31.27	AVG
0.362	25.61	10.08	35.69	58.68	-22.99	QP
0.362	15.3	10.08	25.38	48.68	-23.3	AVG
0.43	25.89	9.98	35.87	57.25	-21.38	QP
0.43	14.97	9.98	24.95	47.25	-22.3	AVG
1.778	25.48	9.79	35.27	56	-20.73	QP
1.798	14.85	9.78	24.63	46	-21.37	AVG
3.586	25.66	9.81	35.47	56	-20.53	QP
3.574	14.55	9.81	24.36	46	-21.64	AVG

Remark:

- Factor = Antenna Factor + Cable Loss – Pre-amplifier.

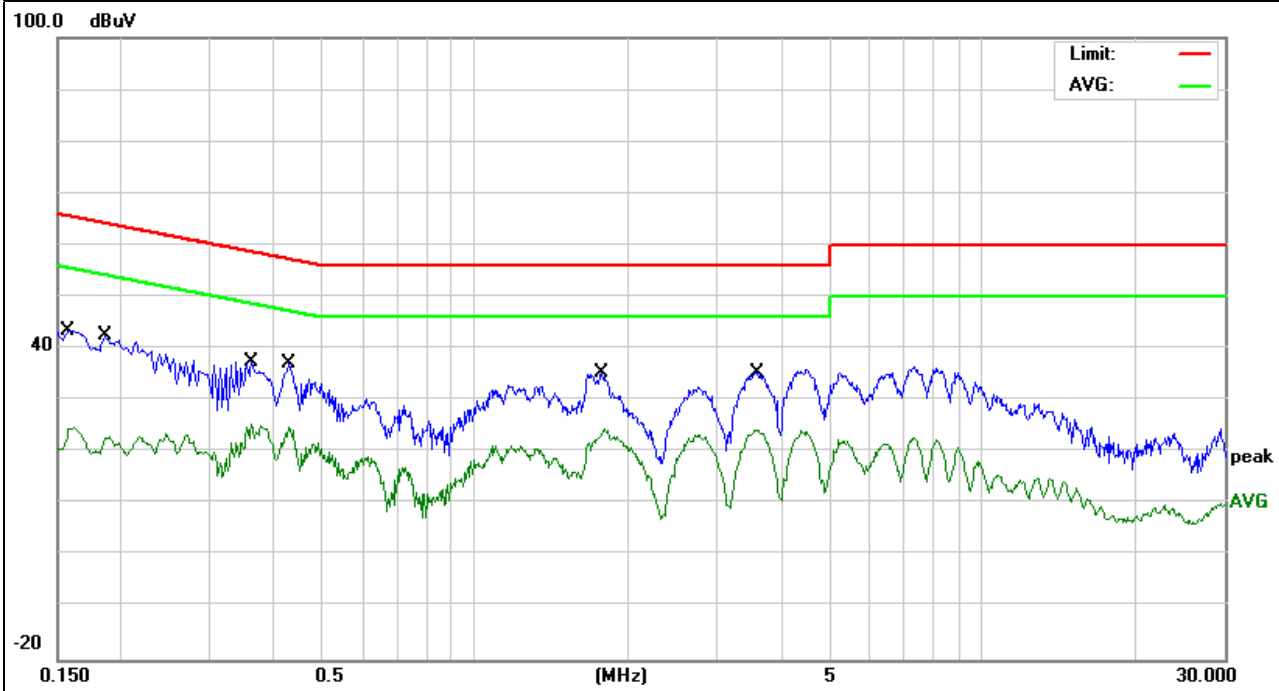

EUT :	Smart center	Model Name :	UCC1
Temperature :	20 °C	Relative Humidity :	48%
Pressure :	1010 hPa	Phase :	N/A
Test Voltage :	DC 5V from Adapter AC240V/60Hz	Test Mode :	N

Frequency (MHz)	Meter Reading (dBµV)	Factor (dB)	Emission Level (dBµV/m)	Limits (dBµV/m)	Margin (dB)	Detector Type
0.162	32.66	10.07	42.73	65.36	-22.63	QP
0.162	13.04	10.07	23.11	55.36	-32.25	AVG
0.1901	31.3	10.03	41.33	64.03	-22.7	QP
0.1901	12.23	10.03	22.26	54.03	-31.77	AVG
0.3659	30.75	10.08	40.83	58.59	-17.76	QP
0.3659	17.98	10.08	28.06	48.59	-20.53	AVG
0.4219	31.42	10.01	41.43	57.41	-15.98	QP
0.4219	18.22	10.01	28.23	47.41	-19.18	AVG
1.1619	24.21	9.87	34.08	56	-21.92	QP
1.1619	11.06	9.87	20.93	46	-25.07	AVG
3.5739	25.67	9.79	35.46	56	-20.54	QP
3.5579	15.74	9.79	25.53	46	-20.47	AVG

Remark:

1. Factor = Antenna Factor + Cable Loss – Pre-amplifier.

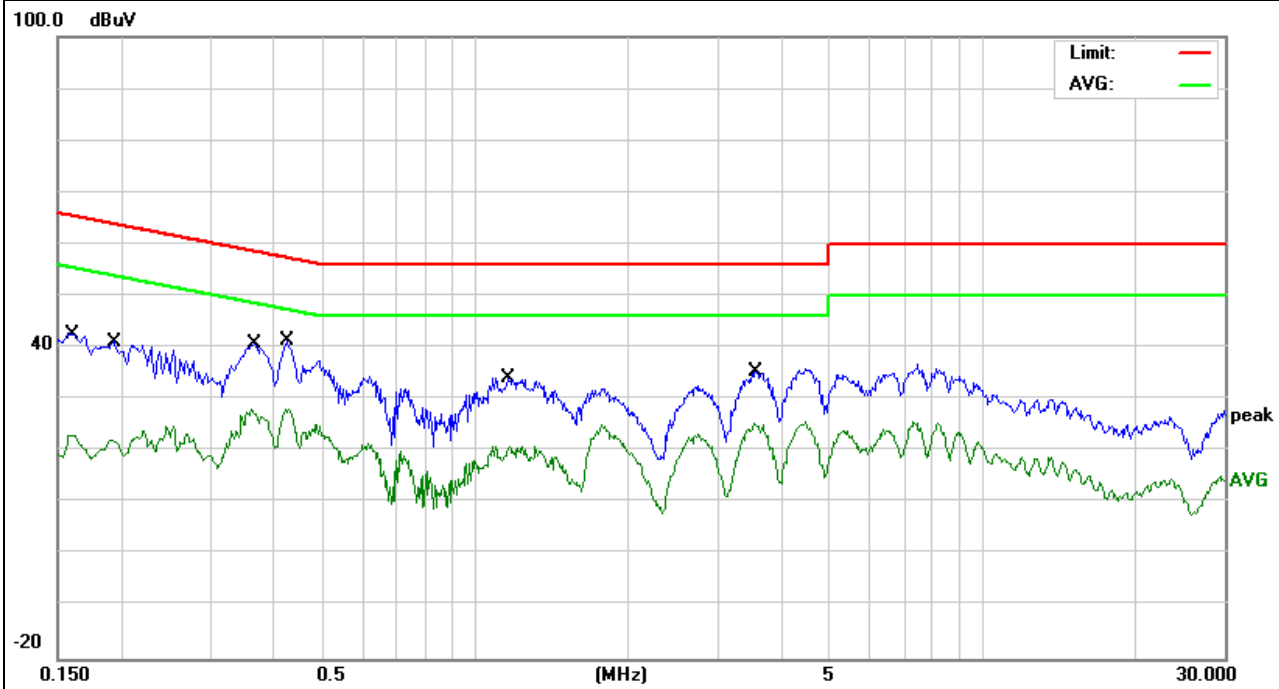

4.4 RADIATED EMISSION MEASUREMENT

4.4.1 Radiated Emission Limits (FCC 15.209)

Frequencies (MHz)	Field Strength (micorvolts/meter)	Measurement Distance (meters)
0.009~0.490	2400/F(KHz)	300
0.490~1.705	24000/F(KHz)	30
1.705~30.0	30	30
Frequency (MHz)	Limit (dBuV)	
30~88	40	3
88~216	43.5	3
216~960	46	3
960 -10000	54.00	3
*902 - 928	94.00	3

Note:

- (1) The tighter limit applies at the band edges.
- (2) Emission level (dBuV/m)=20log Emission level (uV/m).
- (3) *Note: This is the limit for the fundamental frequency.

LIMITS OF RADIATED EMISSION MEASUREMENT (FCC 15.249)

Frequency of Emission (MHz)	Field Strength of fundamental ((millivolts /meter)	Field Strength of Harmonics (microvolts/meter)
902-928	50	500

Notes:

- (1) Emissions radiated outside of the specified frequency bands, except for harmonics, shall be attenuated by at least 50 dB below the level of the fundamental or to the general radiated emission limits in Section 15.209, whichever is the lesser attenuation.

Spectrum Parameter	Setting
Attenuation	Auto
Start Frequency	1000 MHz
Stop Frequency	10th carrier harmonic
RB / VB (emission in restricted band)	1MHz / 1MHz for Peak

Receiver Parameter	Setting
Attenuation	Auto
Start ~ Stop Frequency	9kHz~150kHz / RB 200Hz for QP
Start ~ Stop Frequency	150kHz~30MHz / RB 9kHz for QP
Start ~ Stop Frequency	30MHz~1000MHz / RB 120kHz for QP

4.4.2 TEST PROCEDURE

- a. The measuring distance of at 3 m shall be used for measurements at frequency up to 1GHz. For frequencies above 1GHz, any suitable measuring distance may be used.
- b. The EUT was placed on the top of a rotating table 0.8 m for below 1GHz and 1.5m for above 1GHz the ground at a 3 meter open area test site. The table was rotated 360 degrees to determine the position of the highest radiation.
- c. The height of the equipment or of the substitution antenna shall be 0.8 m for below 1GHz and 1.5m for above 1GHz; the height of the test antenna shall vary between 1 m to 4 m. Both horizontal and vertical polarizations of the antenna are set to make the measurement. Place the measurement antenna away from each area of the EUT determined to be a source of emissions at the specified measurement distance, while keeping the measurement antenna aimed at the source of emissions at each frequency of significant emissions, with polarization oriented for maximum response. The measurement antenna may have to be higher or lower than the EUT, depending on the radiation pattern of the emission and staying aimed at the emission source for receiving the maximum signal. The final measurement antenna elevation shall be that which maximizes the emissions. The measurement antenna elevation for maximum emissions shall be restricted to a range of heights of from 1 m to 4 m above the ground or reference ground plane.
- d. The initial step in collecting conducted emission data is a spectrum analyzer peak detector mode pre-scanning the measurement frequency range. Significant peaks are then marked and then Quasi Peak detector mode re-measured.
- e. If the Peak Mode measured value compliance with and lower than Quasi Peak Mode Limit, the EUT shall be deemed to meet QP Limits and then no additional QP Mode measurement performed.
- f. For the actual test configuration, please refer to the related Item –EUT Test Photos.

Note:

Both horizontal and vertical antenna polarities were tested and performed pretest to three orthogonal axis. The worst case emissions were reported

During the radiated emission test, the Spectrum Analyzer was set with the following configurations:

Frequency Band (MHz)	Function	Resolution bandwidth	Video Bandwidth
30 to 1000	Peak	100 kHz	100 kHz
Above 1000	Peak	1 MHz	1 MHz
	Average	1 MHz	10 Hz

4.4.3 DEVIATION FROM TEST STANDARD

No deviation

4.4.4 TEST SETUP

(A) For radiated emissions below 30MHz

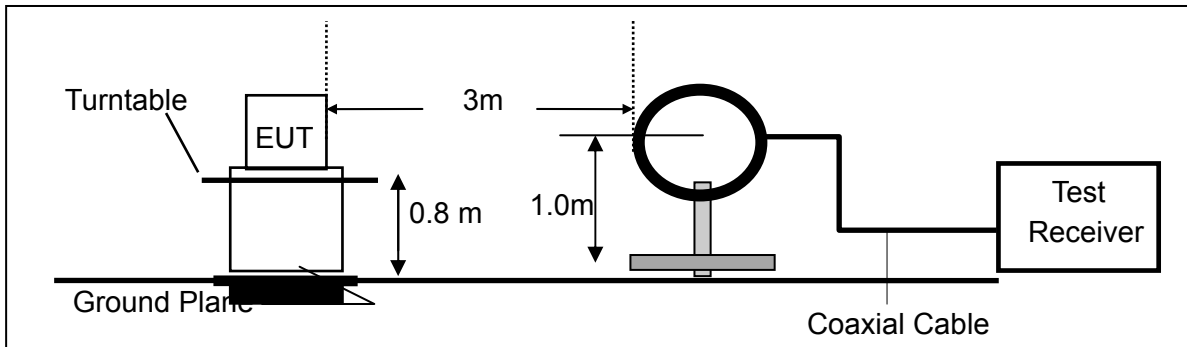

(B) For radiated emissions from 30MHz to 1000MHz

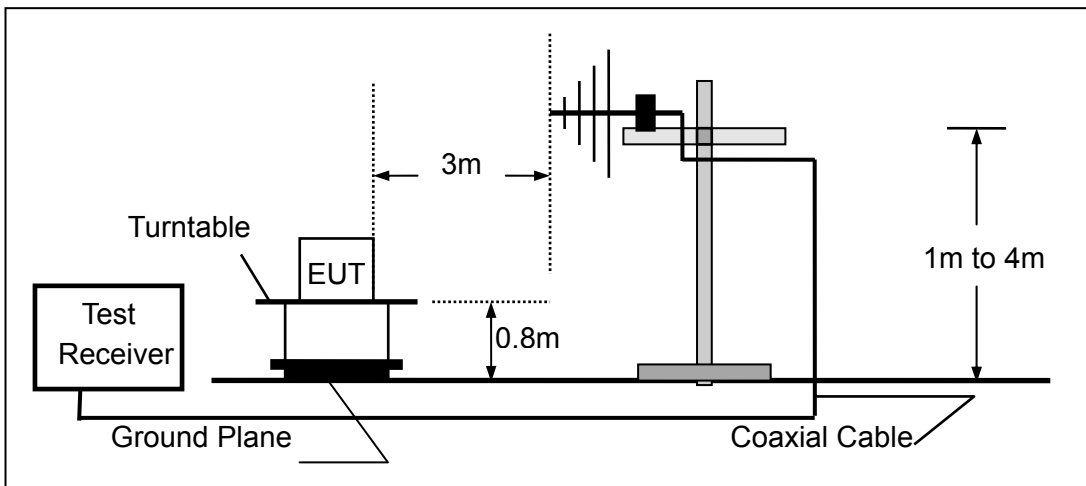

(C) For radiated emissions from Above 1GHz

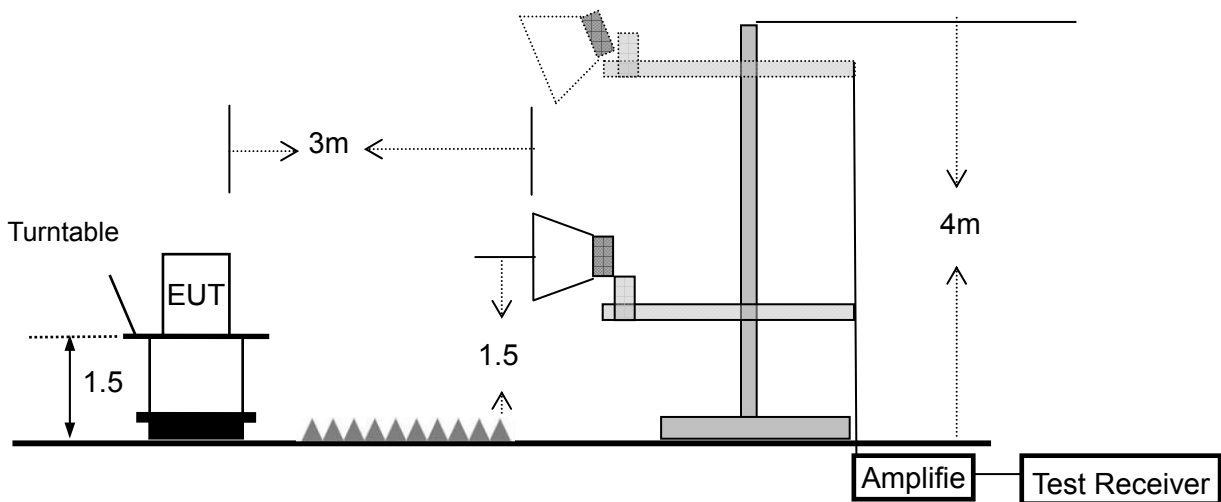

4.4.5 TEST RESULTS (BLOW 30MHz)

EUT :	Smart center	Model Name. :	UCC1
Temperature :	20 °C	Relative Humidity :	48%
Pressure :	1010 hPa	Test Voltage :	DC 5V from Adapter AC 120V/60Hz
Test Mode :	TX	Polarization :	--

Freq. (MHz)	Reading (dBuV/m)	Limit (dBuV/m)	Margin (dB)	State P/F
--	--	--	--	PASS
--	--	--	--	PASS

NOTE:

The amplitude of spurious emissions which are attenuated by more than 20dB below the permissible value has no need to be reported.

Distance extrapolation factor = $20 \log (\text{specific distance}/\text{test distance})(\text{dB})$;

Limit line = specific limits(dBuv) + distance extrapolation factor.

4.4.6 TEST RESULTS (BETWEEN 30 – 1000 MHZ)

EUT :	Smart center	Model Name :	UCC1
Temperature :	20 °C	Relative Humidity :	48%
Pressure :	1010 hPa	Test Voltage :	DC 5V from Adapter AC 120V/60Hz
Test Mode :	TX-2445MHz	Polarization :	Vertical

Frequency (MHz)	Meter Reading (dBμV)	Factor (dB)	Emission Level (dBμV/m)	Limits (dBμV/m)	Margin (dB)	Detector Type
30.1051	6.52	20.2	26.72	40	-13.28	QP
44.2752	11.15	13.1	24.25	40	-15.75	QP
84.4054	6.91	10.09	17	40	-23	QP
137.9028	10.05	12.08	22.13	43.5	-21.37	QP
194.4533	6.16	12.69	18.85	43.5	-24.65	QP
372.0045	5.21	16.01	21.22	46	-24.78	QP

Remark:

- Factor = Antenna Factor + Cable Loss – Pre-amplifier.

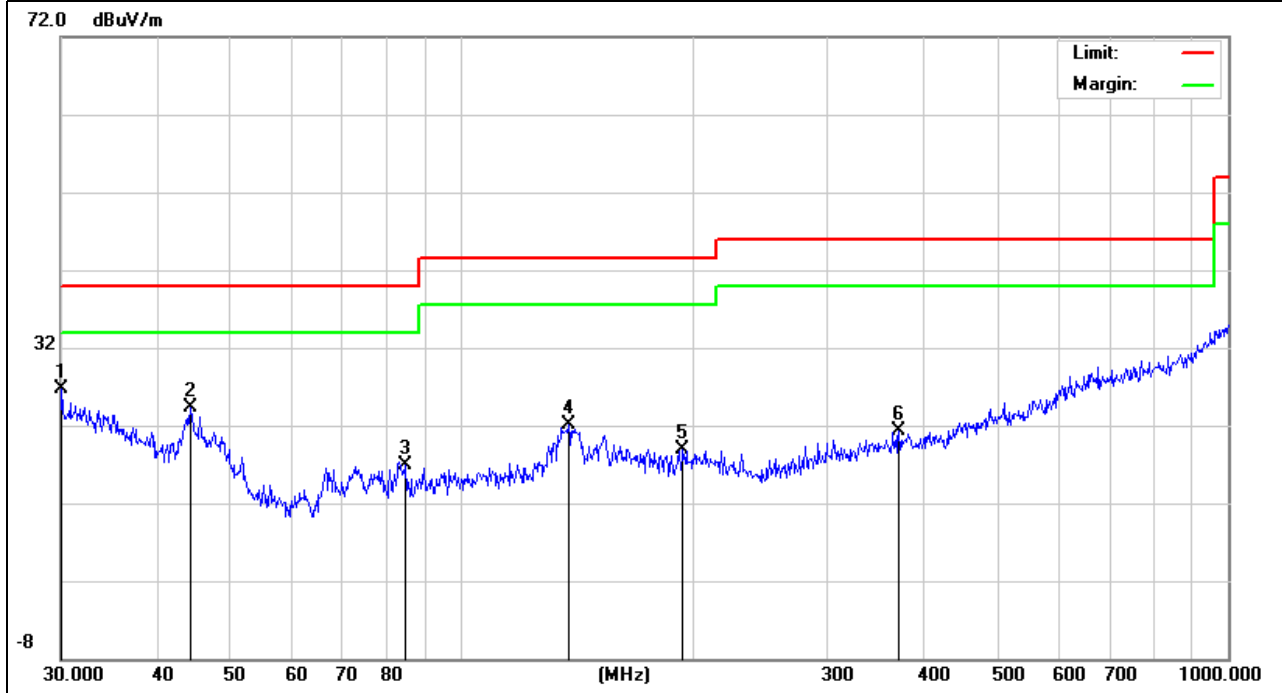

EUT :	Smart center	Model Name :	UCC1
Temperature :	20 °C	Relative Humidity :	48%
Pressure :	1010 hPa	Test Voltage :	DC 5V from Adapter AC 120V/60Hz
Test Mode :	TX-2445MHz	Polarization :	Horizontal

Frequency (MHz)	Meter Reading (dBµV)	Factor (dB)	Emission Level (dBµV/m)	Limits (dBµV/m)	Margin (dB)	Detector Type
31.5092	7.02	19.7	26.72	40	-13.28	QP
35.749	6.73	17.71	24.44	40	-15.56	QP
131.2965	6.01	12.01	18.02	43.5	-25.48	QP
201.393	12.02	12.78	24.8	43.5	-18.7	QP
368.1116	9.62	15.88	25.5	46	-20.5	QP
706.6997	7.52	22.35	29.87	46	-16.13	QP

Remark:

- Factor = Antenna Factor + Cable Loss – Pre-amplifier.

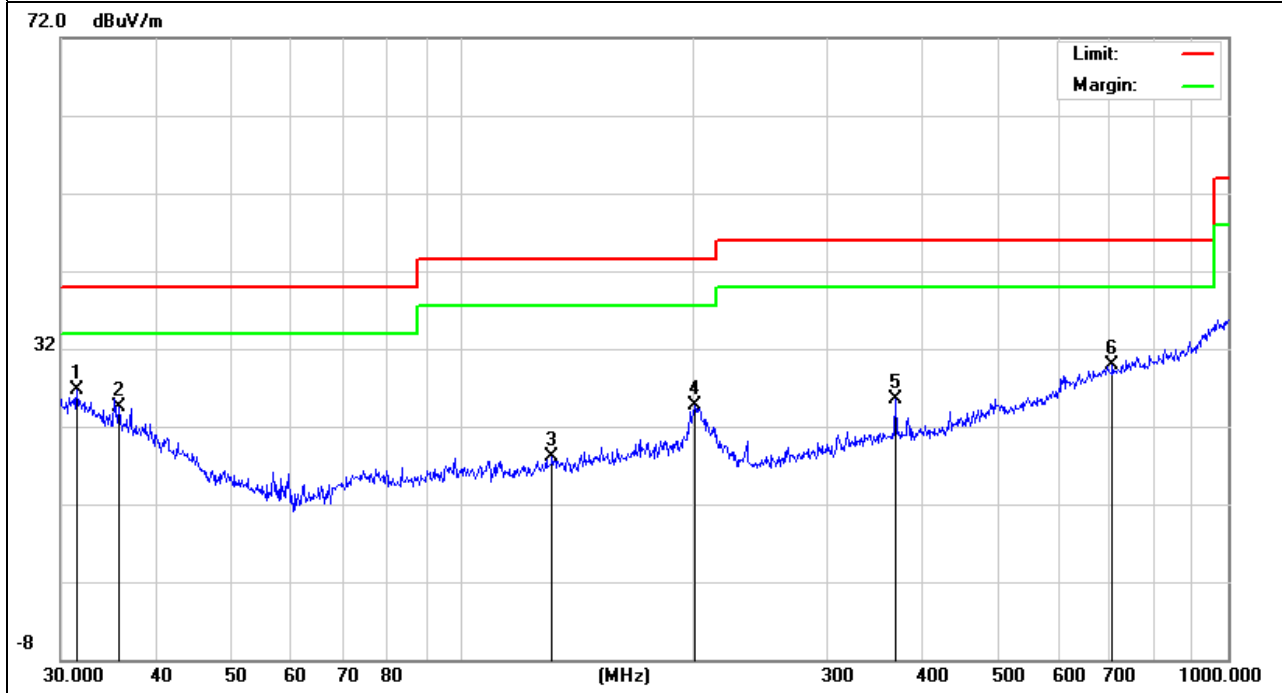

4.4.7 TEST RESULTS (ABOVE 1000 MHZ)

EUT :	Smart center	Model Name :	UCC1
Temperature :	20 °C	Relative Humidity :	48%
Pressure :	1010 hPa	Test Voltage :	DC 5V from Adapter AC 120V/60Hz
Test Mode :	TX-2445MHz	Polarization :	Horizontal

Frequency (MHz)	Meter Reading (dBµV)	Factor (dB)	Emission Level (dBµV/m)	Limits (dBµV/m)	Margin (dB)	Detector Type
2445	108.9	-10.58	98.32	114.0	-15.68	peak
2445	98.8	-10.58	88.22	94	-5.78	AVG
4890.5	65.61	-1.81	63.8	74	-10.2	peak
4890	50.36	-1.8	48.56	54	-5.44	AVG
7332.5	56.83	1.46	58.29	74	-15.71	peak
7332	45.22	1.46	46.68	54	-7.32	AVG
9787.5	62.7	3.9	66.6	74	-7.4	peak
9787	45.57	3.89	49.46	54	-4.54	AVG
12223	53.36	8.44	61.8	74	-12.2	peak
12223	41.37	8.44	49.81	54	-4.19	AVG

Remark:

Factor = Antenna Factor + Cable Loss – Pre-amplifier.

No emission above 18GHz.

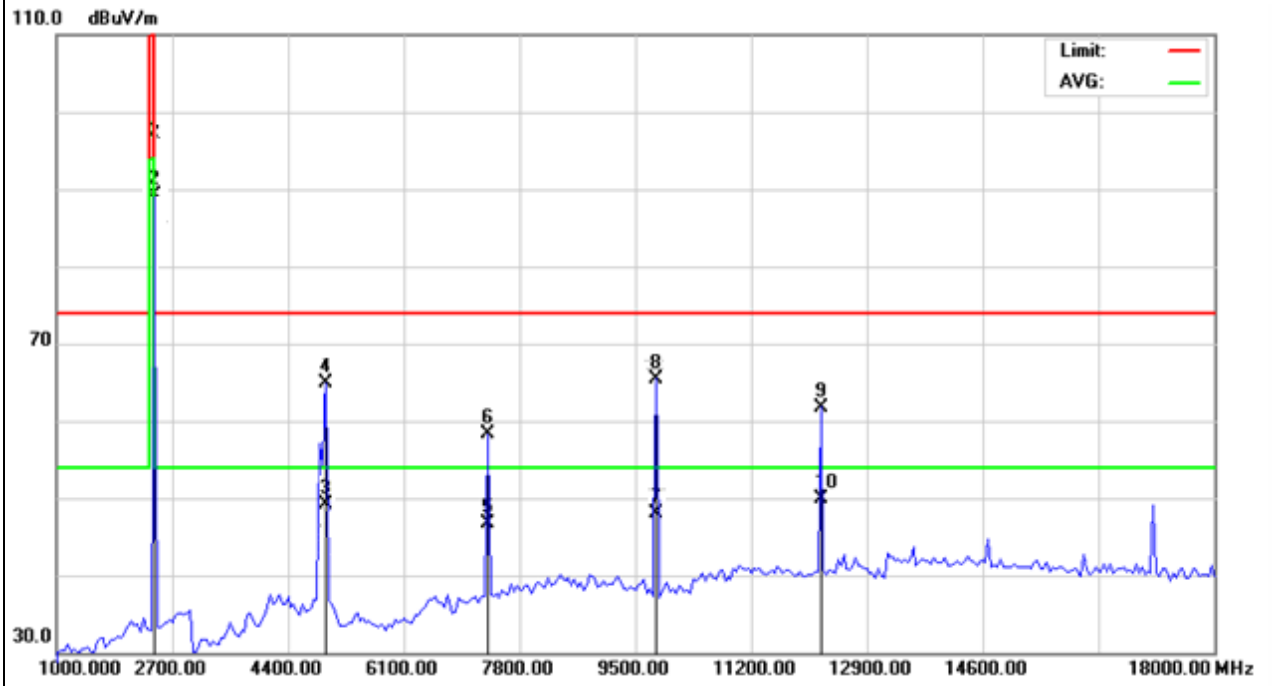

EUT :	Smart center	Model Name :	UCC1
Temperature :	20 °C	Relative Humidity :	48%
Pressure :	1010 hPa	Test Voltage :	DC 5V from Adapter AC 120V/60Hz
Test Mode :	TX-2445MHz	Polarization :	Vertical

Frequency (MHz)	Meter Reading (dBµV)	Factor (dB)	Emission Level (dBµV/m)	Limits (dBµV/m)	Margin (dB)	Detector Type
2445	97.05	-10.58	86.47	114.0	-27.53	peak
2445	93	-10.58	82.42	94	-11.58	AVG
4888.2	65.04	-1.98	63.06	74	-10.94	peak
4889	48.55	-1.96	46.59	54	-7.41	AVG
7332	49.71	1.46	51.17	74	-22.83	peak
7332	43.62	1.46	45.08	54	-8.92	AVG
9786	54.84	3.9	58.74	74	-15.26	peak
9786	43.04	3.93	46.97	54	-7.03	AVG
12223	45.88	8.44	54.32	74	-19.68	peak
12223	41.12	8.44	49.56	54	-4.44	AVG

Remark:
 Factor = Antenna Factor + Cable Loss – Pre-amplifier.
 No emission above 18GHz.

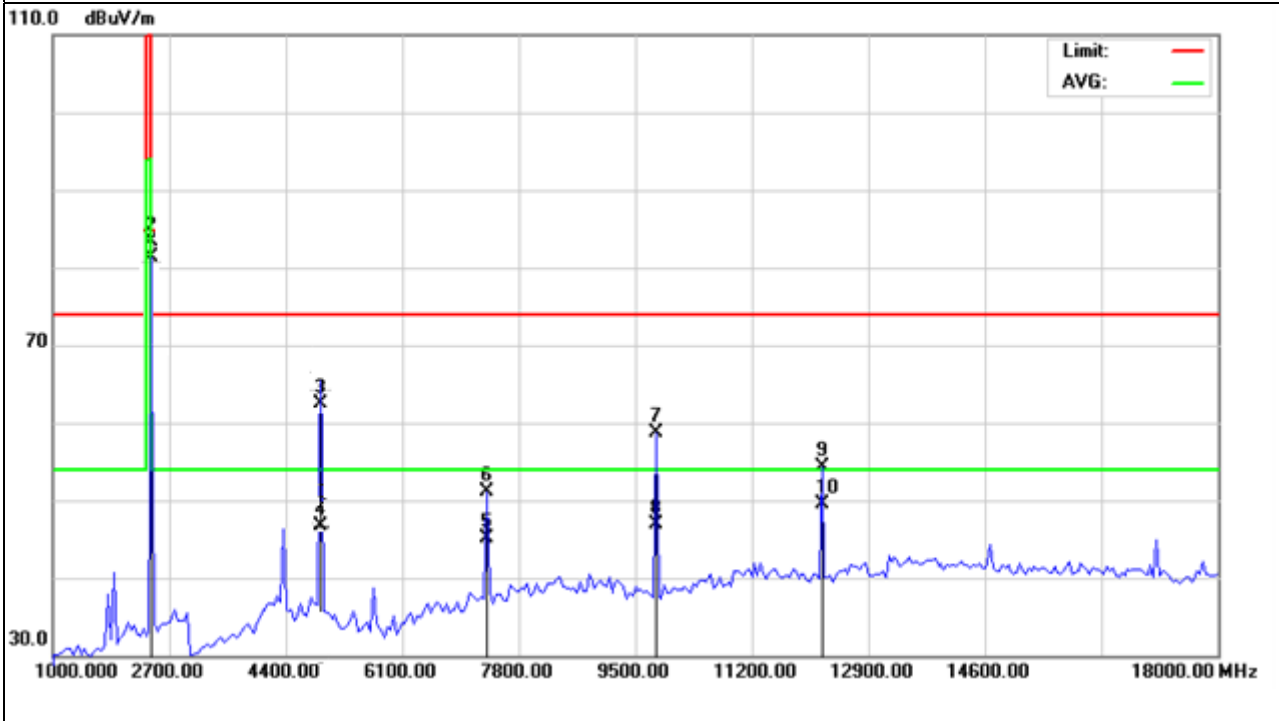

Note: EUT Pre-scan X/Y/Z orientation, only worst case is presented in the report(X orientation).

4.4.8 TEST RESULTS (RESTRICTED BANDS REQUIREMENTS)

EUT :	Smart center	Model Name :	UCC1
Temperature :	20 °C	Relative Humidity :	48%
Pressure :	1010 hPa	Test Voltage :	DC 5V from Adapter AC 120V/60Hz
Test Mode :	TX -2445MHz	Polarization :	Vertical

Frequency (MHz)	Meter Reading (dBµV)	Factor (dB)	Emission Level (dBµV/m)	Limits (dBµV/m)	Margin (dB)	Detector Type
2399.514	40.96	-4.67	36.29	74	-37.71	peak
2445.028	90.32	-5.99	84.33	114.0 0	-29.67	peak
2484.064	40.56	-6.4	34.16	74	-39.84	peak

Remark:
 Factor = Antenna Factor + Cable Loss – Pre-amplifier.

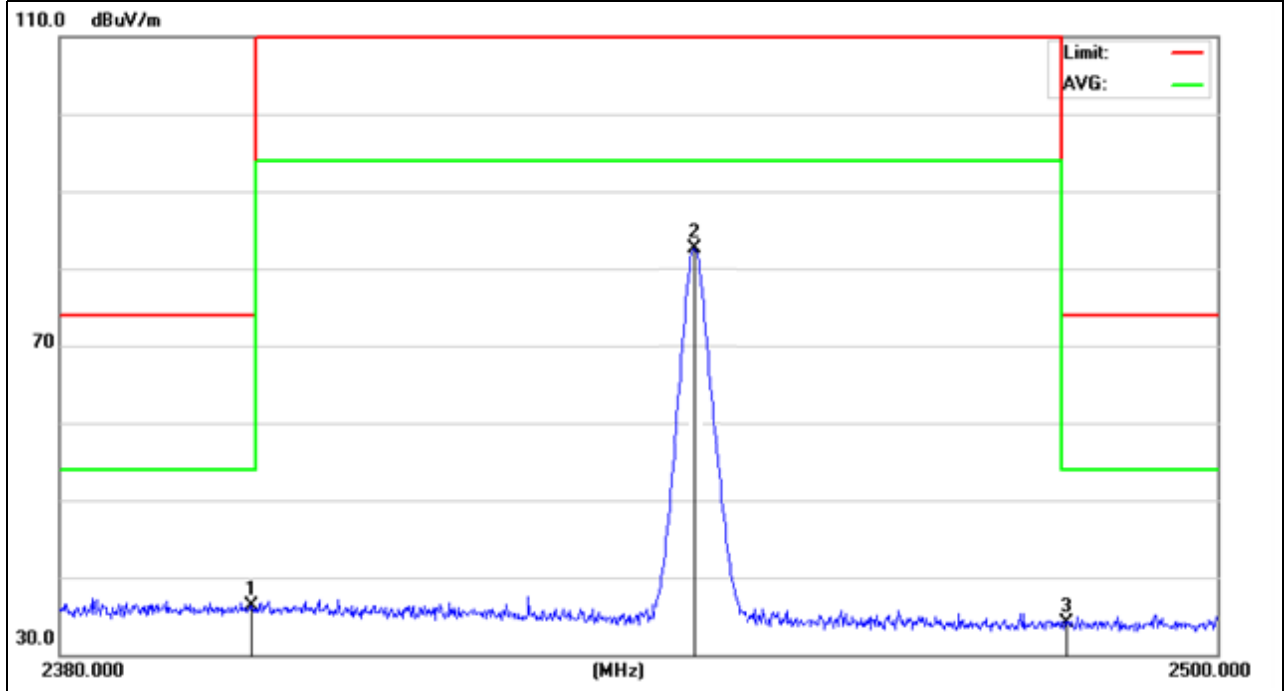

EUT :	Smart center	Model Name :	UCC1
Temperature :	20 °C	Relative Humidity :	48%
Pressure :	1010 hPa	Test Voltage :	DC 5V from Adapter AC 120V/60Hz
Test Mode :	TX -2445MHz	Polarization :	Horizontal

Frequency (MHz)	Meter Reading (dBμV)	Factor (dB)	Emission Level (dBμV/m)	Limits (dBμV/m)	Margin (dB)	Detector Type
2400	40.93	-4.67	36.26	74	-37.74	peak
2445.04	103.83	-5.99	97.84	114.0 0	-16.16	peak
2483.5	41.85	-6.4	35.45	74	-38.55	peak

Remark:
Factor = Antenna Factor + Cable Loss – Pre-amplifier.

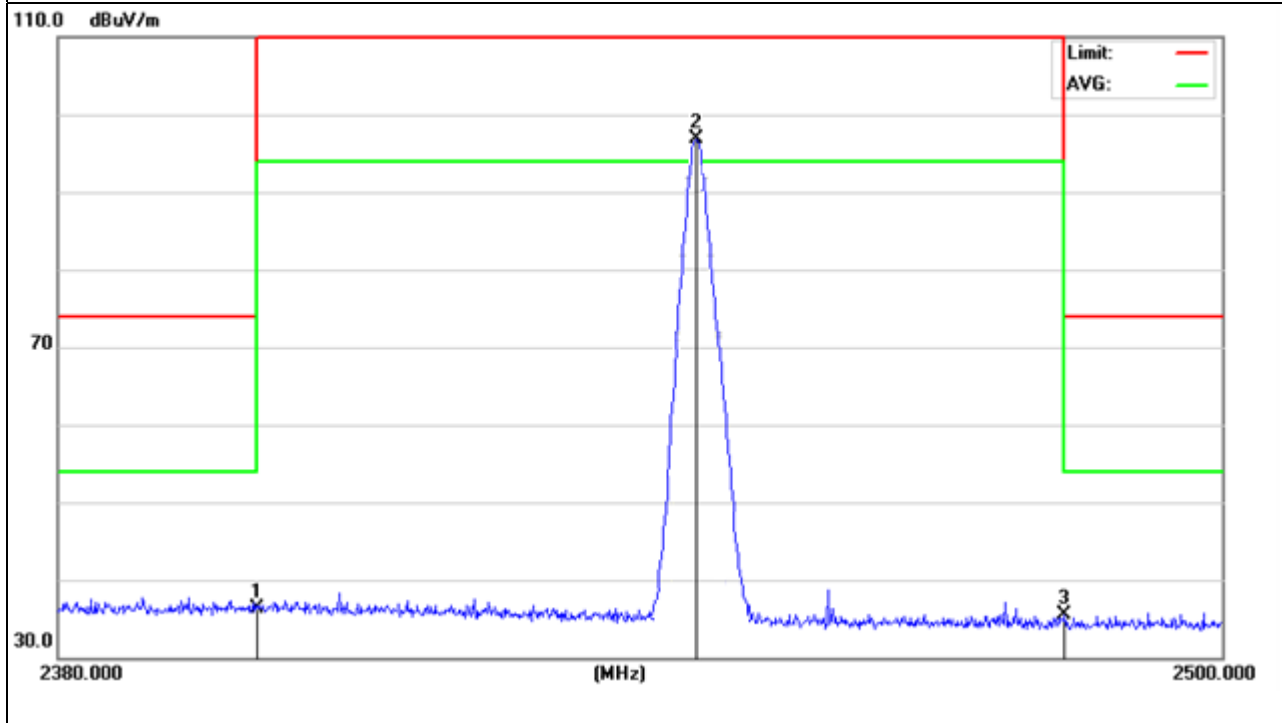

5. BANDWIDTH TEST

5.1 TEST PROCEDURE

- a. The EUT was directly connected to the spectrum analyzer and antenna output port as show in the block diagram below,
- b. Spectrum Setting : RBW= 100KHz, VBW \geq RBW, Sweep time = Auto.

5.2 DEVIATION FROM STANDARD

No deviation.

5.3 TEST SETUP



5.4 TEST RESULTS

EUT :	Smart center	Model Name :	UCC1
Temperature :	26 °C	Relative Humidity :	53%
Pressure :	1020 hPa	Test Power :	DC 5V from Adapter AC 120V/60Hz
Test Mode :	TX		

Test Channel	Frequency (MHz)	20 dBc Bandwidth (kHz)
CH01	2445	398.822

2445 MHz

