

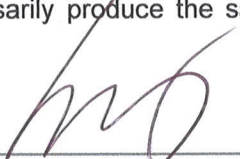

Electromagnetic Emission
FCC MEASUREMENT REPORT
CERTIFICATION OF COMPLIANCE
FCC Part 15 Certification Measurement

PRODUCT : HP Sprocket Photo Printer
MODEL/Serial No. : SNPRH-1603 / KR66B1004X
MULTIPLE MODEL : -
BRAND NAME : 
FCC ID : 2AJJ9SNPRH-1603
APPLICANT : DSGLOBAL CO., LTD.
107, Gasan digital 2-ro, Geumcheon-gu, Seoul, KOREA
Attn.: In Jong Na / R&D Hardware Engineer
MANUFACTURER : HP Information Technology R&D (Shanghai) Co., Ltd.
Room203-C, No.26 Jia Feng Road, Waigaoqiao Free Trade Zone,
Pudong, Shanghai, 200131 P.R, CHINA
FACTORY : DSGLOBAL CO., LTD.
107, Gasan digital 2-ro, Geumcheon-gu, Seoul, KOREA
EQUIMENT CLASSIFICATION : DSS (Part 15 Spread Spectrum Transmitter)
TYPE OF MODULATION : FHSS (GFSK (BDR), 8DPSK (EDR))
FREQUENCY CHANNEL : 2 402 MHz to 2 480 MHz and Channel Spacing 1 MHz (79 Ch)
AIR DATE RATE : BDR (1 Mbps), EDR (2 Mbps, 3 Mbps)
ANTENNA TYPE : Chip Antenna (Integral)
ANTENNA GAIN : 1.80 dBi max
RF POWER : 3.61 mW
RULE PART(S) : FCC Part 15 Subpart C
FCC PROCEDURE : ANSI C63.10-2013
TEST REPORT No. : ETLT160721.0083
DATES OF TEST : August 03, 2016 to August 11, 2016
REPORT ISSUE DATE : August 22, 2016
TEST LABORATORY : ETL Inc. (FCC Designation Number : KR0022)

The HP Sprocket Photo Printer, Model SNPRH-1603 has been tested in accordance with the measurement procedures specified in ANSI C63.10-2013 at the ETL Test Laboratory and has been shown to be complied with the electromagnetic radiated emission limits specified in FCC Rule Part15 Subpart C section 15.247. I attest to the accuracy of data. All measurement herein was performed by me or was made under my supervision and is correct to the best of my knowledge and belief. I assume full responsibility for the completeness of these measurements and vouch for the qualifications of all persons taking them. The results of testing in this report apply to the product/system which was tested only. Other similar equipment will not necessarily produce the same results due to production tolerance and measurement uncertainties.

Prepared by: 
Dong Jin, Seo (Test Engineer)
August 22, 2016

Reviewed by: 
Kug Kyoung, Yoon (Chief Engineer)
August 22, 2016

ETL Inc.
Head office: #371-51, Gasan-dong, Geumcheon-gu, Seoul, 153-803, Korea
Open site: #499-1, Sagot-ri, Seosin-myeon, Hwaseong-si, Gyeonggi-do, 445-882, Korea
Tel: 82-2-858-0786 Fax: 82-2-858-0788

*The test report merely corresponds to the test sample(s).
This report shall not be reproduced, in whole or in part without the written approval of ETL Inc.*

Table of Contents

FCC Measurement Report

- 1. Introduction**
- 2. Product Information**
- 3. Description of Tests**
- 4. Test Condition**
- 5. Test Results**
 - 5.1 Summary of Test Results**
 - 5.2 Channel Bandwidth and Frequency Separation**
 - 5.3 Maximum Peak Output Power**
 - 5.4 Bandwidth of Frequency Band Edges**
 - 5.5 Number of Hopping Channels**
 - 5.6 Time of Occupancy (Dwell time)**
 - 5.7 Spurious Emissions**
 - 5.8 Conducted Emissions Test**
 - 5.9 Radio Frequency Exposure**
- 6. Sample Calculation**
- 7. List of test Equipment used for Measurement**

FCC MEASUREMENT REPORT

Scope – Measurement and determination of electromagnetic emission (EME) of radio frequency devices including intentional radiators and/or unintentional radiators for compliance with the technical rules and regulations of the U.S Federal Communications Commission(FCC)

General Information

Applicant Name	: DSGLOBAL CO., LTD.
Address	: 107, Gasan digital 2-ro, Geumcheon-gu, Seoul, KOREA
Attention	: In Jong Na / R&D Hardware Engineer

- **EUT Type** : HP Sprocket Photo Printer
- **Model Number** : SNPRH-1603
- **S/N** : KR66B1004X
- **Freq. Range** : 2 402 MHz - 2 480 MHz
- **Number of Channels** : 79
- **Modulation Technique** : FHSS (GFSK (BDR), 8DPSK (EDR))
- **Frequency Channel** : 2 402 MHz to 2 480 MHz and Channel Spacing 1 MHz (79 Ch)
- **Air Data Rate** : BDR (1 Mbps), EDR (2 Mbps, 3 Mbps)
- **Antenna Type** : Chip Antenna (Integral)
- **Antenna Gain** : 1.80 dBi max
- **RF Power** : 3.61 mW
- **Environmental of Tests** : Temperature: (29.2 ± 6.2) °C
Humidity: (58 ± 12) % R.H.
Atmospheric Pressure: (100.9 ± 0.1) kPa
- **FCC Rule Part(s)** : FCC Part 15 Subpart C
- **Test Procedure** : ANSI C63.10-2013
- **Equipment Class** : DSS (Part 15 Spread Spectrum Transmitter)
- **Place of Tests** : ETL Inc. Testing Lab. (FCC Designation Number : KR0022)

Radiated Emission test 1;
#499-1, Sagot-ri, Seosin-myeon, Hwaseong-si,
Gyeonggi-do, 445-882, Korea

Radiated Emission test 2 and Conducted Emission test;
#371-51, Gasan-dong, Geumcheon-gu, Seoul, 153-803, Korea

1. INTRODUCTION

The measurement test for radiated and conducted emission test was conducted at the ETL Inc. The site is constructed in conformance with the requirements of the ANSI C63.10-2013 and CISPR Publication 16. The ETL has site descriptions on file with the FCC for 3 m and 10 m site configurations. Detailed description of test facility was found to be in compliance with FCC Rules according to the ANSI C63.10-2013 and registered to the Federal Communications Commission (FCC Designation Number : KR0022).

The measurement procedure described in American National Standard for Method of Measurement of Radio-Noise Emission from Low-Voltage Electrical and Electronic Equipment in the Range of 9 kHz to 40 GHz (ANSI C63.10-2013) was used in determining radiated and conducted emissions from the DSGLOBAL CO., LTD. Model: SNPRH-1603

2. PRODUCT INFORMATION

2.1 Equipment Description

The Equipment Under Test (EUT) is the HP Sprocket Photo Printer (model: SNPRH-1603).

The model SNPRH-1603 is basic model that was tested.

2.2 General Specification

Item	Specification
Paper size	50 mm x 76 mm
Type of supported image file / Size	PNG (2 550 x 3 300) JPEG (baseline) Within a maximum of 10 M Byte Progressive JPEG not supported
Paper used	ZINK Paper (for Pomini only)
Paper storage conditions	Temperature: (22.5 ± 2.5) °C
	Humidity: (47.5 ± 7.5) % R.H.
Product operating conditions	Temperature: (22.5 ± 17.5) °C
	Humidity: Less than 70 % (35 °C)
Optimal print conditions	Temperature: (23.5 ± 8.5) °C
	Humidity: Less than 70 % (32 °C)
LED display	Power on / Standby / Communication / Charge / Error / Print / Update
Communication	Bluetooth 4.0
External connection terminal	Micro USB port (charging only)
USB power supply	Rated DC 5 V / 1.0 A Adapter (optional)
Normal operating voltage	DC 8 V
Built-in battery	500 mAh Lithium-ion (rechargeable)
Proper image resolution	More than 1 280 pixel x 2 448 pixel
Weight	186 g
Support App version	Android: 4.0 or higher iOS: 5.1 or higher (Support may not be provided depending on the user's Smartphone version and environment.)
High Internal Frequency	Memory clock → 264 MHz

3. DESCRIPTION OF TESTS

The tests documented in this report were performed in accordance with ANSI C63.10-2013 and FCC CFR 47 2.1046, 2.1047, 2.1049, 2.1051, 2.1053, 2.1055, 2.1057, 15.207, 15.209 and 15.247.

3.1 Radiated Emission Measurement

Radiated emission measurements were made in accordance with § 13 in ANSI C63.10-2013 "Measurement of Intentional radiators". The measurements were performed over the frequency range of 30 MHz to 40 GHz using antenna as the input transducer to a Spectrum analyzer or a Field Intensity Meter. The measurements were made with the detector set for "Peak, Quasi-peak, Average" within a bandwidth of 120 kHz and above 1 GHz is 1 MHz.

Preliminary measurements were made at 3 m using broadband antennas, and spectrum analyzer to determine the frequency producing the maximum emission in shielded room. Appropriate precaution was taken to ensure that all emission from the EUT were maximized and investigated. The system configuration, mode of operation, turntable azimuth and height with respect to the antenna were noted for each frequency found. The spectrum was scanned from 30 MHz to 1 000 MHz using Log-Bicon antenna. Above 1 GHz, linearly polarized double ridge horn antennas were used. Final measurements were made open site or SVSWR chamber at 3 m. The test equipment was placed on a styrofoam table. Sufficient time for the EUT, support equipment, and test equipment was allowed in order for them to warm up to their normal operating condition. Each frequency found during pre-scan measurements was re-examined by manual. The EUT, support equipment and interconnecting cables were re-configured to the set-up producing the maximum emission for the frequency and were placed on top of a table height for below 1GHz is 0.8 m, and for above 1GHz is 1.5 m. nonmetallic 1.0 m x 1.5 m table. The EUT, support equipment, and interconnecting cables were re-arranged and manipulated to maximize each emission. The turntable containing the system was rotated; the antenna height was varied 1 m to 4 m and stopped at the azimuth or height producing the maximum emission.

Varying the mode of operating frequencies of the EUT maximized each emission. The system was tested in all the three orthogonal planes and changing the polarity of the antenna. The worst-case emissions are recorded in the data tables. If necessary, the radiated emission measurement could be performed at a closer distance to ensure higher accuracy and the results were extrapolated to the specified distance using an inverse linear distance extrapolation factor (20 dB/decade) as per section 15.31(f).

Photographs of the worst-case emission can be seen in Photographs of the worst-case emission test setup can be seen in Appendix B.

3.2 Conducted Emission Measurement

Conducted emissions measurements were made in accordance with section § 13 in ANSI C63.10-2013 "measurement of intentional radiators" The measurements were performed over the frequency range of 0.15 MHz to 30 MHz using a 50 Ω /50 μ H LISN as the input transducer to a Spectrum Analyzer or a Test Receiver. The measurements were made with the detector set for "Peak" amplitude within a bandwidth of 9 kHz or for "quasi-peak" within a bandwidth of 9 kHz.

The line-conducted emission test is conducted inside a shielded anechoic chamber room with 1 m x 1.5 m x 0.8 m wooden table which is placed 0.4 m away from the vertical wall and 1.5 m away from the side wall of the chamber room. Two LISN are bonded to the shielded room. The EUT is powered from the LISN and the support equipment is powered from the other LISN. Power to the LISNs are filtered by a noise cut power line filters. If the EUT is a DC-powered device, power will be derived from the source power supply it normally will be powered from and these supply lines will be connected to the LISN. Non-inductive bundling to a 1 m length shortened all interconnecting cables more than 1 m. Sufficient time for the EUT, support equipment, and test equipment was allowed in order for them to warm up to their normal operating condition. The RF output of the LISN was connected to the EMI Test Receiver to determine the frequency producing the maximum emission from the EUT. The frequency producing the maximum level was reexamined using to set Quasi-Peak mode by manual, after scanned by automatic Peak mode from 0.15 MHz to 30 MHz. The bandwidth of the spectrum analyzer was set to 9 kHz. The EUT, support equipment, and interconnecting cables were arranged and manipulated to maximize each emission.

Photographs of the worst-case emission can be seen in Photographs of the worst-case emission test setup can be seen in Appendix B.

3.3 FCC Part 15.205 Restricted Bands of Operations

(a) Except as shown in paragraph (d) of this section, only spurious emissions are permitted in any of the frequency bands listed below:

MHz	MHz	MHz	GHz
0.090 - 0.110	16.42 - 16.423	399.9 - 410	4.5 - 5.15
¹ 0.495 - 0.505	16.694 75 - 16.695 25	608 - 614	5.35 - 5.46
2.173 5 - 2.190 5	16.804 25 - 16.804 75	960 - 1 240	7.25 - 7.75
4.125 - 4.128	25.5 - 25.67	1 300 - 1 427	8.025 - 8.5
4.177 25 - 4.177 75	37.5 - 38.25	1 435 - 1 626.5	9.0 - 9.2
4.207 25 - 4.207 75	73 - 74.6	1 645.5 - 1 646.5	9.3 - 9.5
6.215 - 6.218	74.8 - 75.2	1 660 - 1 710	10.6 - 12.7
6.267 75 - 6.268 25	108 - 121.94	1 718.8 - 1 722.2	13.25 - 13.4
6.311 75 - 6.312 25	123 - 138	2 200 - 2 300	14.47 - 14.5
8.291 - 8.294	149.9 - 150.05	2 310 - 2 390	15.35 - 16.2
8.362 - 8.366	156.524 75 - 156.525 25	2 483.5 - 2 500	17.7 - 21.4
8.376 25 - 8.386 75	156.7 - 156.9	2 690 - 2 900	22.01 - 23.12
8.414 25 - 8.414 75	162.012 5 - 167.17	3 260 - 3 267	23.6 - 24.0
12.29 - 12.293	167.72 - 173.2	3 332 - 3 339	31.2 - 31.8
12.519 75 - 12.520 25	240 - 285	3 345.8 - 3 358	36.43 - 36.5
12.576 75 - 12.577 25	322 - 335.4	3 600 - 4 400	(²)
13.36 - 13.41			

¹ Until February 1, 1999, this restricted band shall be 0.490 MHz - 0.510 MHz.

² Above 38.6

(b) Except as provided in paragraphs (d) and (e), the field strength of emissions appearing within these frequency bands shall not exceed the limits shown in Section 15.209. At frequencies equal to or less than 1 000 MHz, compliance with the limits in Section 15.209 shall be demonstrated using measurement instrumentation employing a CISPR quasi-peak detector. Above 1 000 MHz, compliance with the emission limits in Section 15.209 shall be demonstrated based on the average value of the measured emissions. The provisions in Section 15.35 apply to these measurements.

3.4 Antenna connection requirement

(1) According to §15.203

An intentional radiator shall be designed to ensure that no antenna other than that furnished by the responsible party shall be used with the device. The use of a permanently attached antenna or of an antenna that uses a unique coupling to the intentional radiator shall be considered sufficient to comply with the provisions of this Section. The manufacturer may design the unit so that a broken antenna can be replaced by the user, but the use of a standard antenna jack or electrical connector is prohibited. This requirement does not apply to carrier current devices or to devices operated under the provisions of Sections 15.211, 15.213, 15.217, 15.219, or 15.221. Further, this requirement does not apply to intentional radiators that must be professionally installed, such as perimeter protection systems and some field disturbance sensors, or to other intentional radiators which, in accordance with Section 15.31(d), must be measured at the installation site. However, the installer shall be responsible for ensuring that the proper antenna is employed so that the limits in this Part are not exceeded.

4. TEST CONDITION

4.1 Test Configuration

The device was configured for testing in a typical fashion (as a customer would normally use it). During the tests, the following conditions and configurations were used.

* This test was applied to X, Y, Z. and the worst result were investigated and reported.

4.2 Description of Test modes

HP Sprocket Photo Printer that has the control software.

4.3 The setup drawing(s)

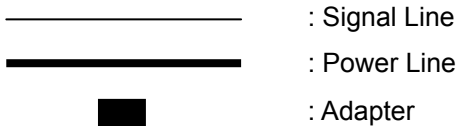
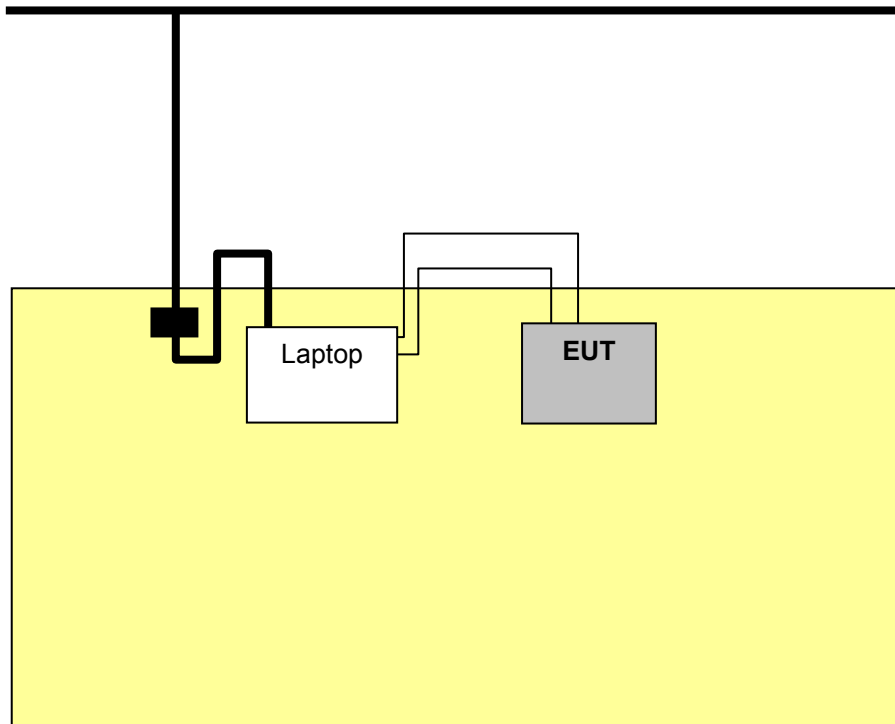

5. TEST RESULTS

5.1 Summary of Test Results

The measurement results were obtained with the EUT tested in the conditions described in this report. Detailed measurement data and plots showing the maximum emission of the EUT are reported.

47 CFR Part 15, Subpart C	Measurement Required	Result
15.247(a)(1)	Channel Bandwidth, Frequency Separation	Pass
15.247(b)(3)	Maximum Peak Output Power	Pass
15.247(d)	Bandwidth of Frequency Band Edges	Pass
15.247(a)(1)(iii)	Number of Hopping Channels	Pass
15.247(a)(1)(iii)	Time of Occupancy (Dwell time)	Pass
15.209(a)	Spurious Emissions	Pass
15.207	Conducted Emissions	Pass
15.203	Antenna connection requirement	Integral antenna which is permanently attached and cannot be replaced.
15.247(i) 1.1307(b)(1)	RF Exposure	Pass

** This test was tested at main host computer (EUT was connected USB port of the host computer).*

The data collected shows that the **DSGLOBAL CO., LTD. / HP Sprocket Photo Printer / SNPRH-1603** complied with technical requirements of above rules part 15.207, 209 and 15.247 Limits.

The equipment is not modified anything, mechanical or circuits to improve EMI status during a measurement. No EMI suppression device(s) was added and/or modified during testing.

5.2 Channel Bandwidth and Frequency Separation

EUT	HP Sprocket Photo Printer / SNPRH-1603
Limit apply to	FCC Part 15.247(a)(1)
Test Date	August 04, 2016
Environmental of Test	(23.2 ± 0.0) °C, (47 ± 0) % R.H., (100.9 ± 0.0) kPa
Operating Condition	RF transmitting continuously during the tested.
Result	Passed

5.2.1 Channel Bandwidth

Type of Modulation	Frequency [MHz]	20 dB Bandwidth [MHz]	Limit
BDR	2 402	0.812	2/3 of the 20 dB Bandwidth < Carrier frequency separation
	2 441	0.812	
	2 480	0.812	
EDR	2 402	1.280	
	2 441	1.270	
	2 480	1.270	

NOTES:

1. Measure frequency separation of relevant channel using spectrum analyzer.
2. Please see the measured plot in next page.

5.2.2 Frequency Separation

Frequency hopping systems operating in the 2 400.0 MHz - 2 483.5 MHz band may have hopping channel carrier frequencies that are separated by 25 kHz or two-thirds of the 20 dB bandwidth of the hopping channel, whichever is greater.

Type of Modulation	EUT Channel Separation [MHz]	20 dB bandwidth [MHz]	Limit
BDR	1.000 (Worst)	0.812 (Worst)	> 25 kHz or > 2/3 of the 20 dB Bandwidth
EDR	1.000 (Worst)	1.280 (Worst)	

NOTES:

1. Measure frequency separation of relevant channel using spectrum analyzer.
2. Please see the measured plot in next page.

Plots of 20 dB Bandwidth (BDR)

[2 402 MHz]

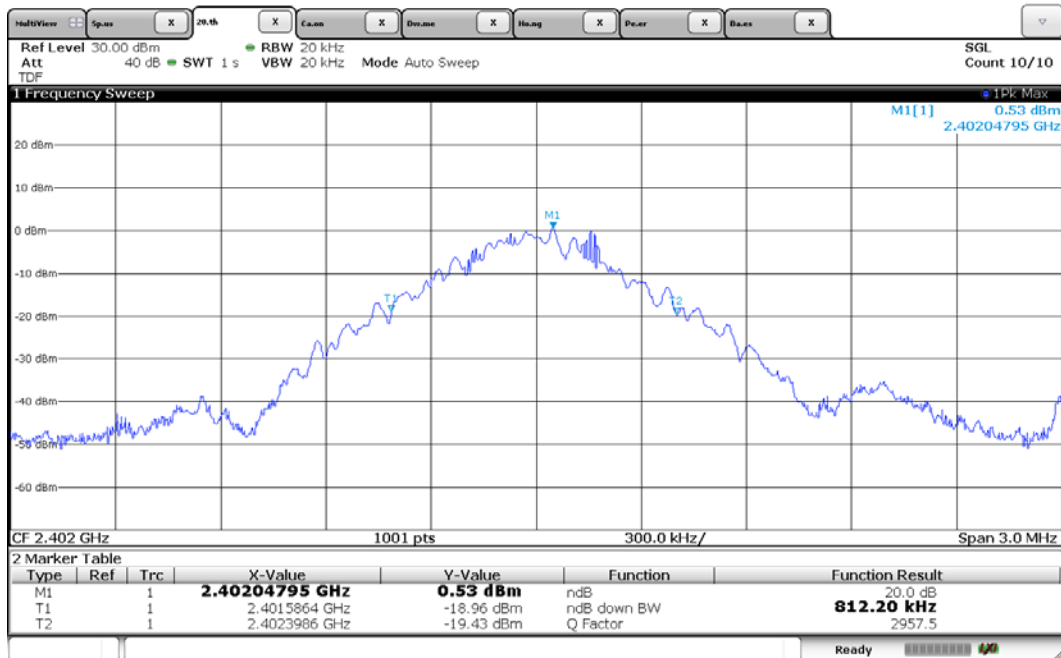

[2 441 MHz]

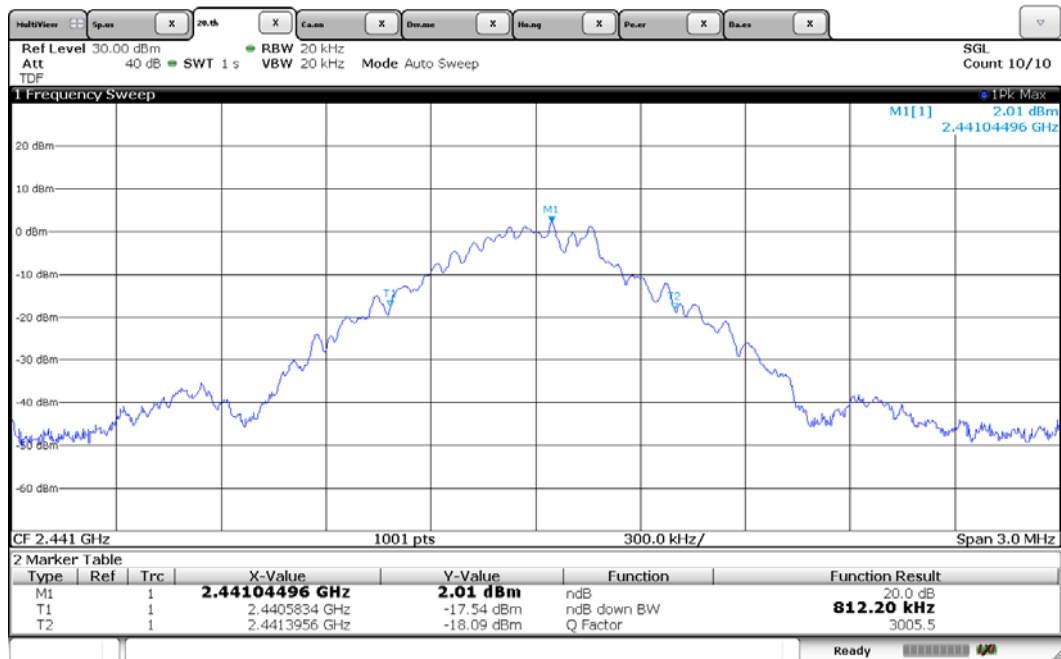

[2 480 MHz]

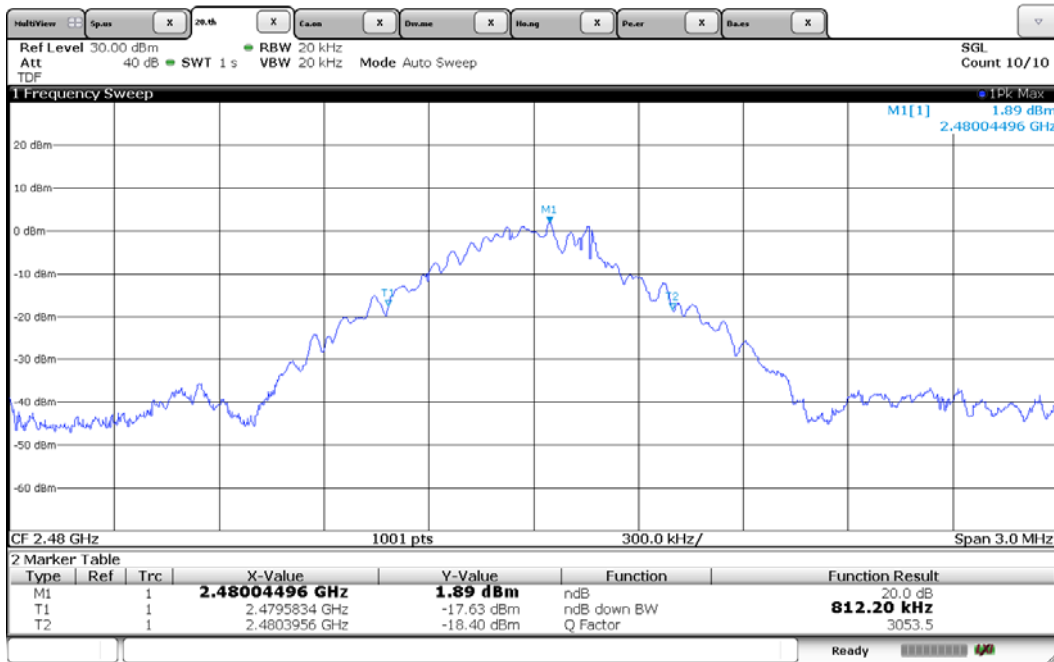

Plots of Frequency Separation (BDR)

[Channel Separation]

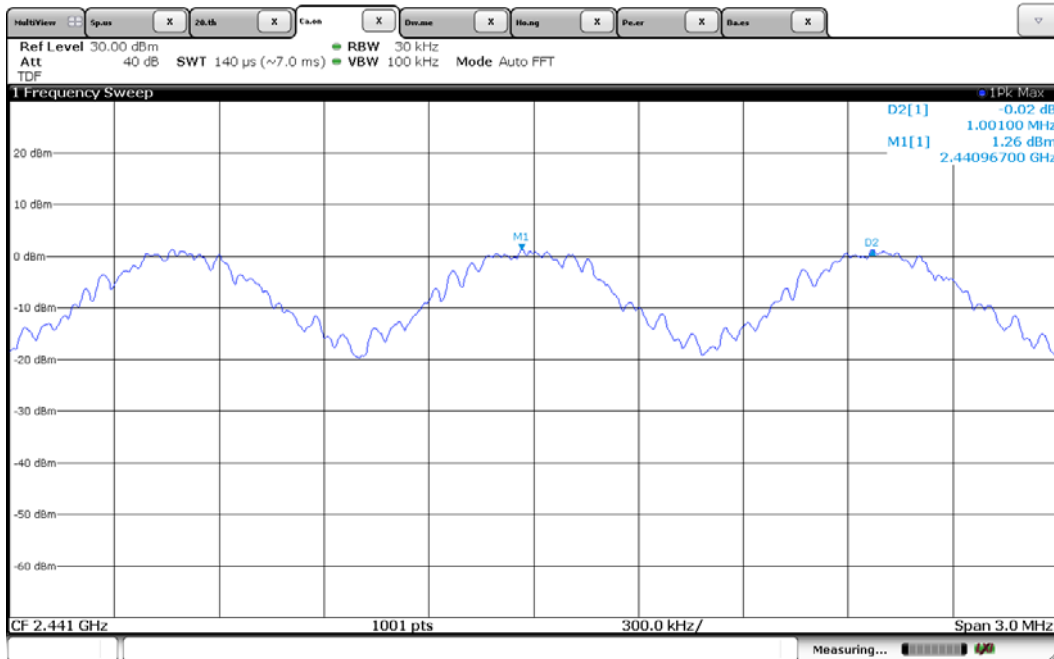

Plots of 20 dB Bandwidth (EDR)

[2 402 MHz]

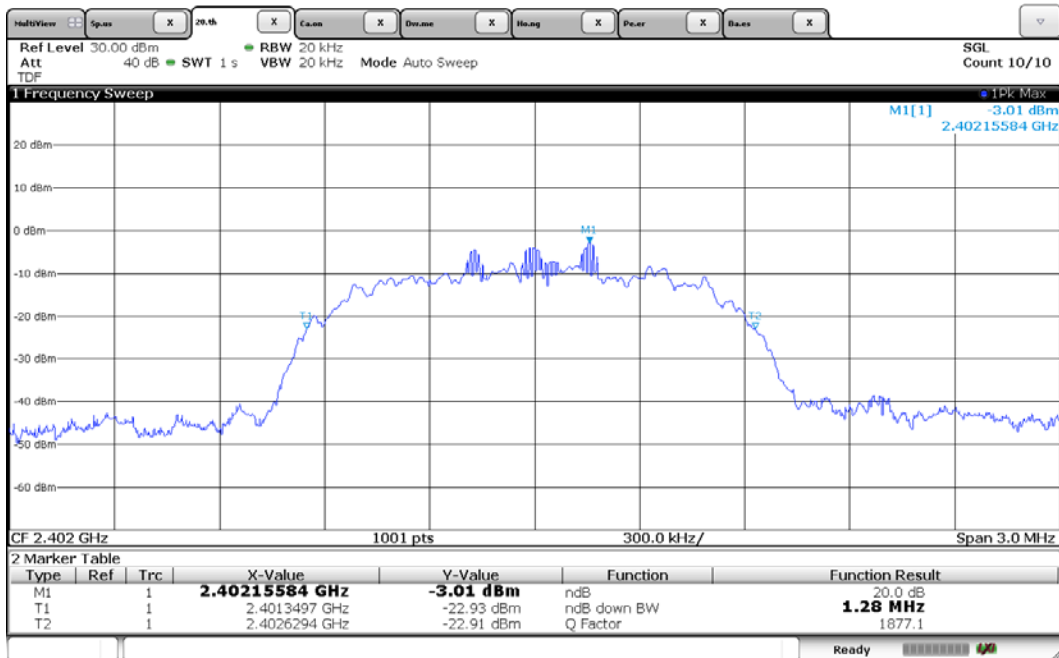

[2 441 MHz]

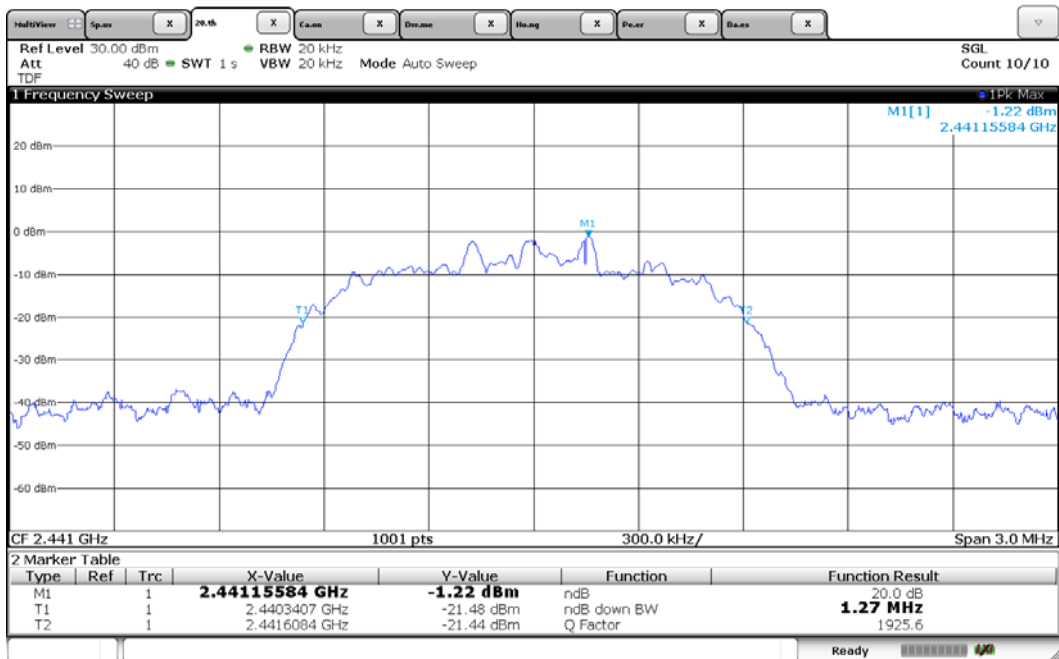

[2 480 MHz]

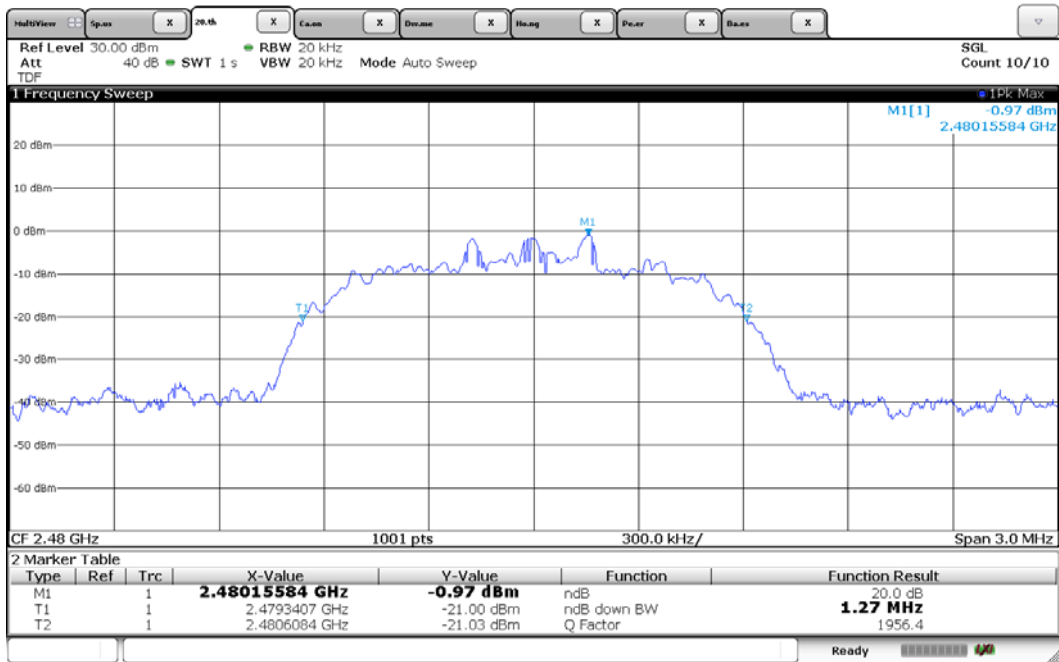

Plots of Frequency Separation (EDR)

[Channel Separation]

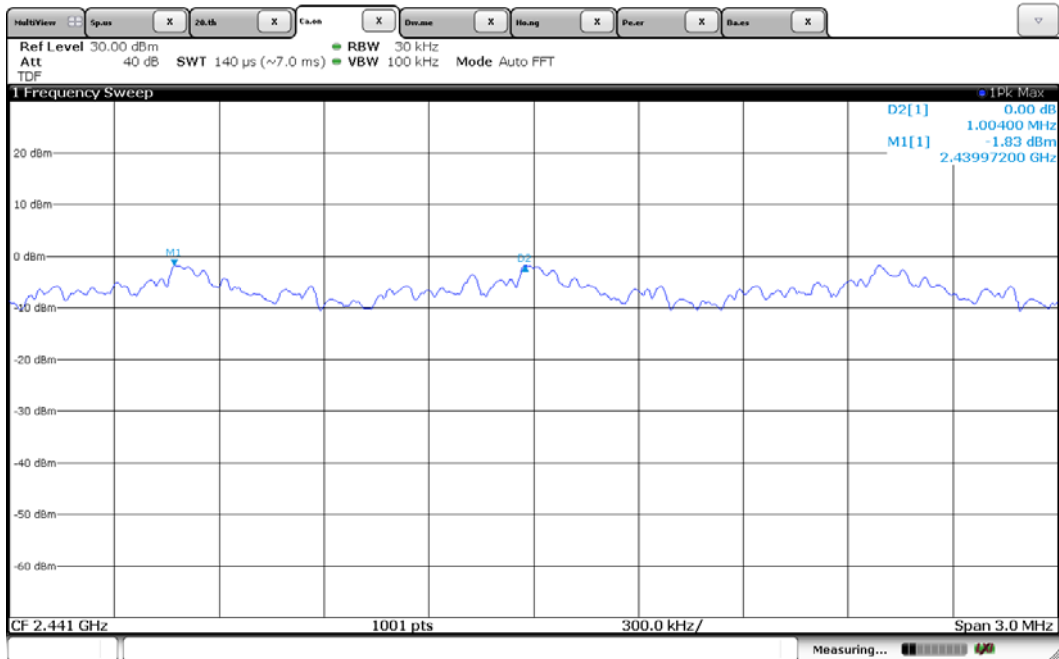

5.3 Maximum Peak Conducted Output Power

EUT	HP Sprocket Photo Printer / SNPRH-1603
Limit apply to	FCC Part 15.247(b)(3)
Test Date	August 04, 2016
Environmental of Test	(23.2 ± 0.0) °C, (47 ± 0) % R.H., (100.9 ± 0.0) kPa
Operating Condition	RF transmitting continuously during the tested.
Result	Passed

Limit

The maximum peak conducted output power of the intentional radiator shall not exceed the following:

For frequency hopping systems operating in the 2 400.0 MHz - 2 483.5 MHz band employing at least 75 non-overlapping hopping channels: 0.125 Watt

Test Data

Type of Modulation	Channel	Frequency [MHz]	Output Power [dBm]	Limit
BDR	Low	2 402	4.35	< 21 dBm (0.125 W)
	Mid	2 441	5.57	
	High	2 480	5.50	
EDR	Low	2 402	2.79	
	Mid	2 441	4.42	
	High	2 480	4.55	

NOTES:

1. Measure conducted Channel power of relevant channel using Spectrum analyzer
2. BDR(RBW 1 MHz, VBW 10 MHz), EDR(RBW 1 MHz, VBW 10 MHz),
3. Please see the measured plot in next page.

Plots of Maximum Peak Output Power (BDR)

[2 402 MHz]

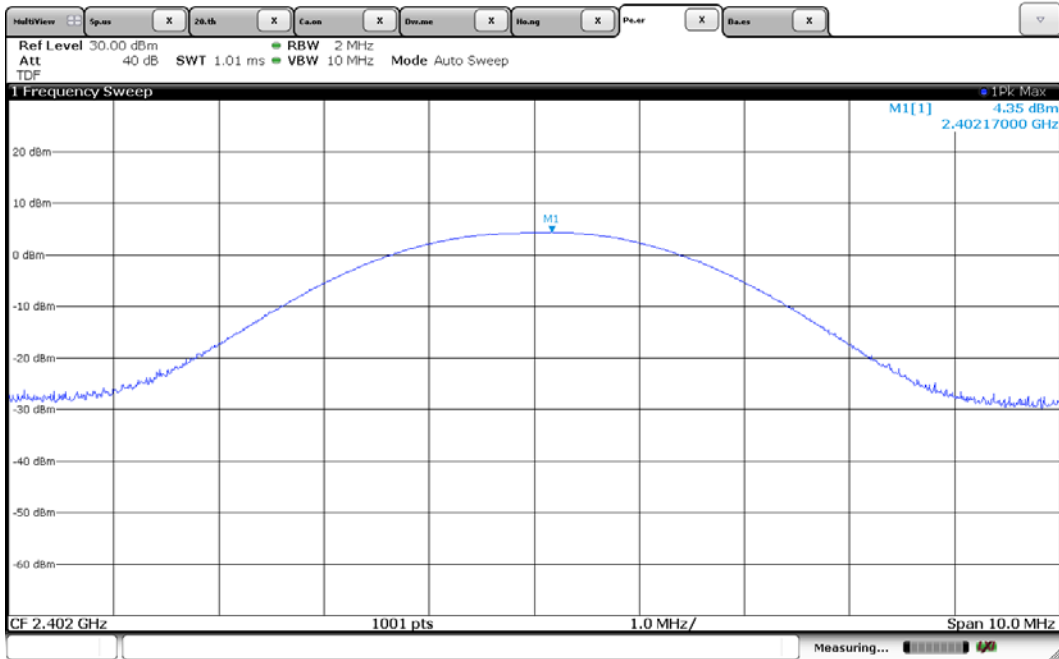

[2 441 MHz]

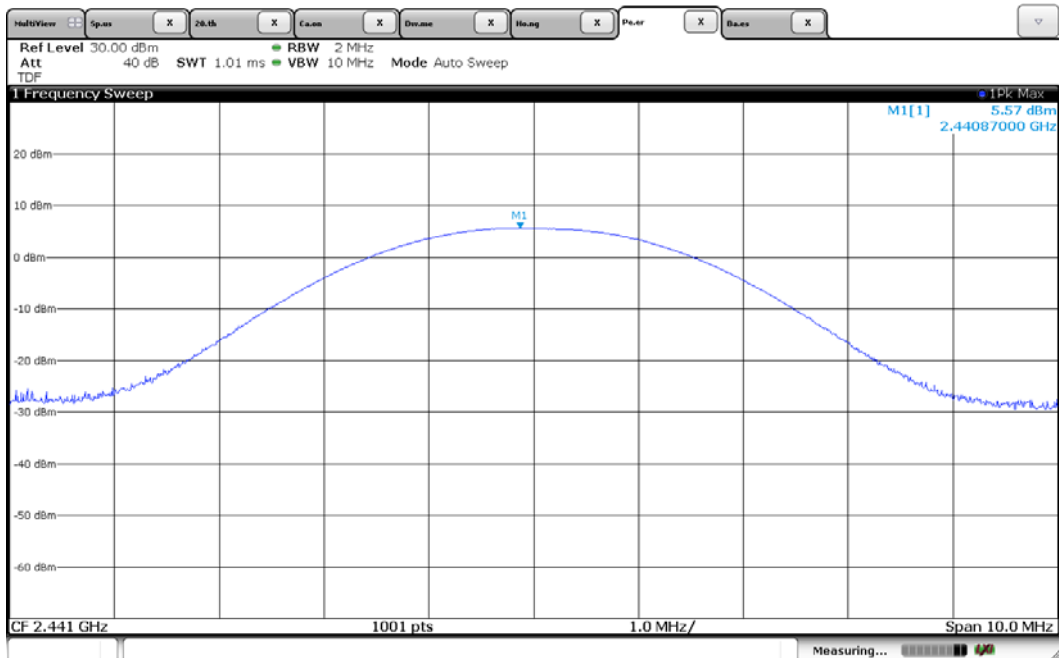

[2 480 MHz]

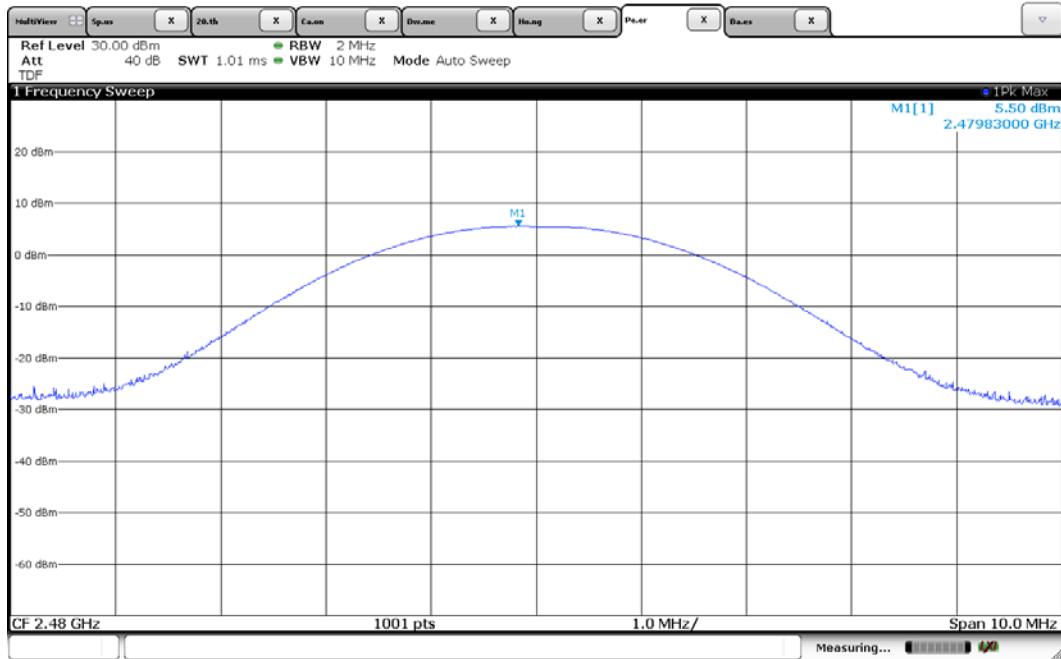

Plots of Maximum Peak Output Power (EDR)

[2 402 MHz]

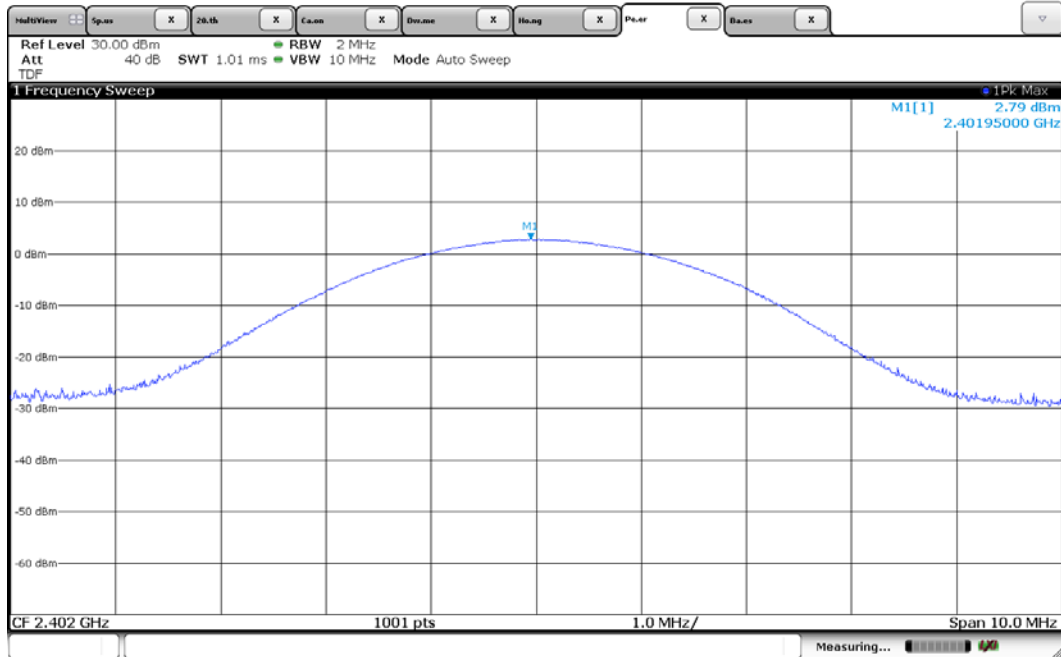

[2 441 MHz]

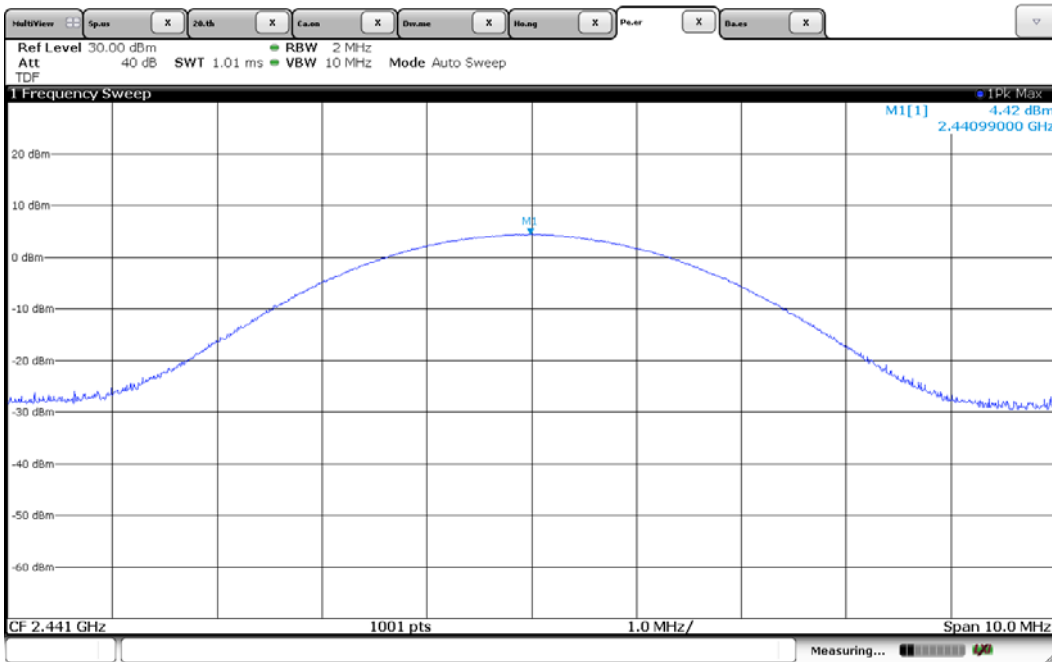

[2 480 MHz]

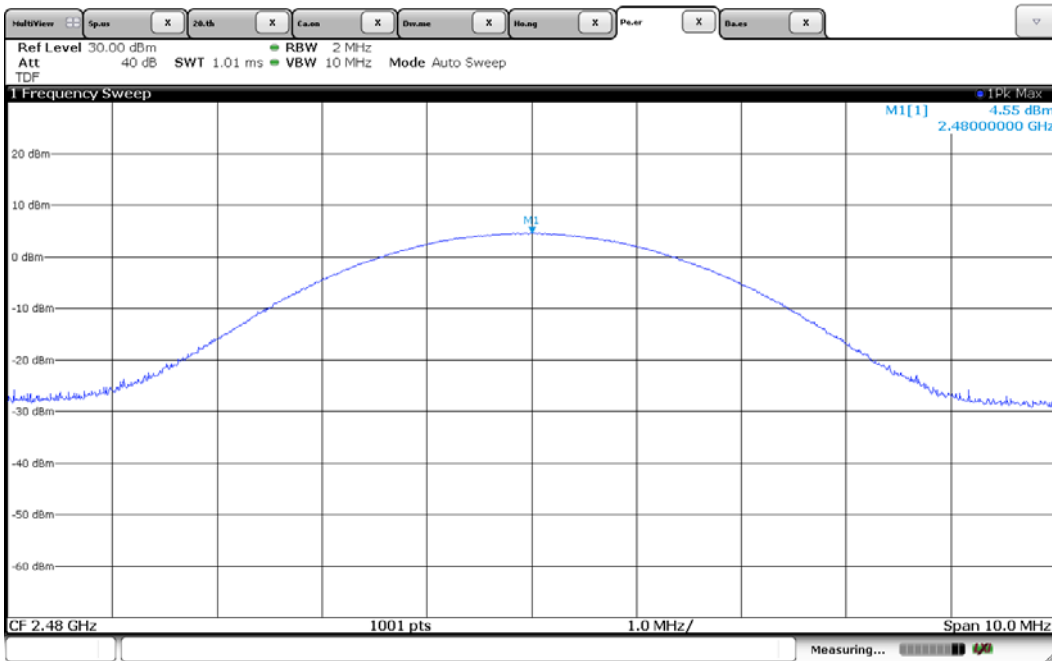

5.4 Bandwidth of Frequency Band Edges

EUT	HP Sprocket Photo Printer / SNPRH-1603
Limit apply to	FCC Part 15.247(d)
Test Date	August 05, 2016
Environmental of Test	(23.9 ± 0.2) °C, (48 ± 0) % R.H., (100.8 ± 0.0) kPa
Operating Condition	RF transmitting continuously during the tested.
Result	Passed

Limit

In any 100 kHz bandwidth outside the frequency band in which the spread spectrum or digitally modulated intentional radiator is operating, the radio frequency power that is produced by the intentional radiator shall be at least 20 dB below that in the 100 kHz bandwidth within the band that contains the highest level of the desired power, based on either an RF conducted or a radiated measurement, provided the transmitter demonstrates compliance with the peak conducted power limits. If the transmitter complies with the conducted power limits based on the use of RMS averaging over a time interval, as permitted under paragraph (b)(3) of this section, the attenuation required under this paragraph shall be 30 dB instead of 20 dB. Attenuation below the general limits specified in Section 15.209(a) is not required. In addition, radiated emissions which fall in the restricted bands, as defined in Section 15.205(a), must also comply with the radiated emission limits specified in Section 15.209(a) (see Section 15.205(c)).

Test Results

- Refer to see the measured plot in next page.

NOTES:

1. The test was performed to make a direct field strength measurement at the band edge frequencies.

Plots of Bandwidth of Frequency Band Edges (BDR)

[Non-hopping mode]

Conducted

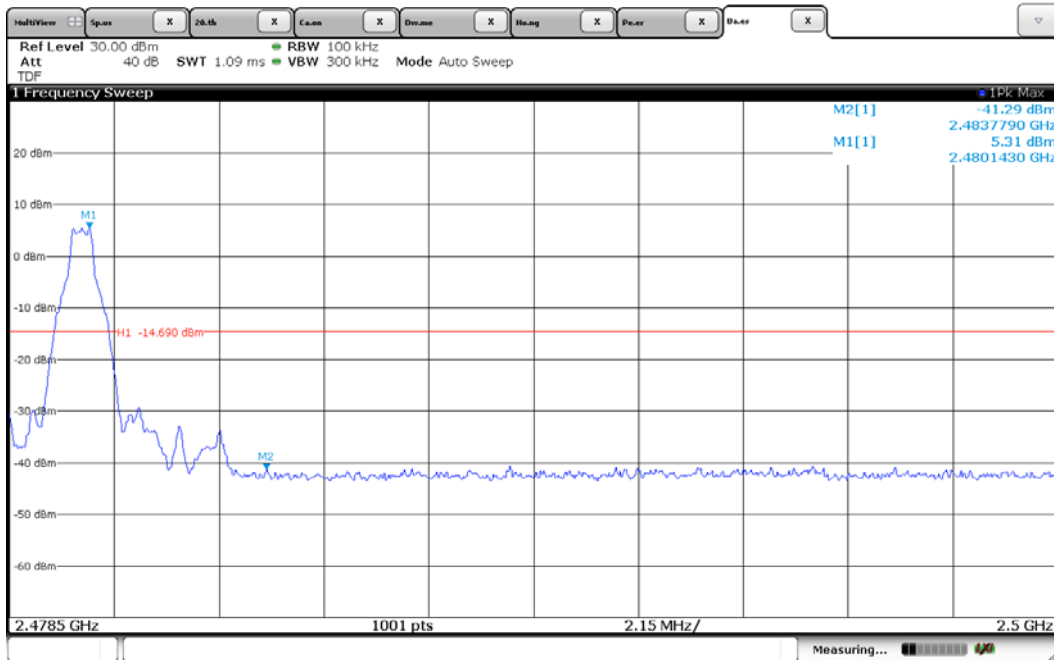
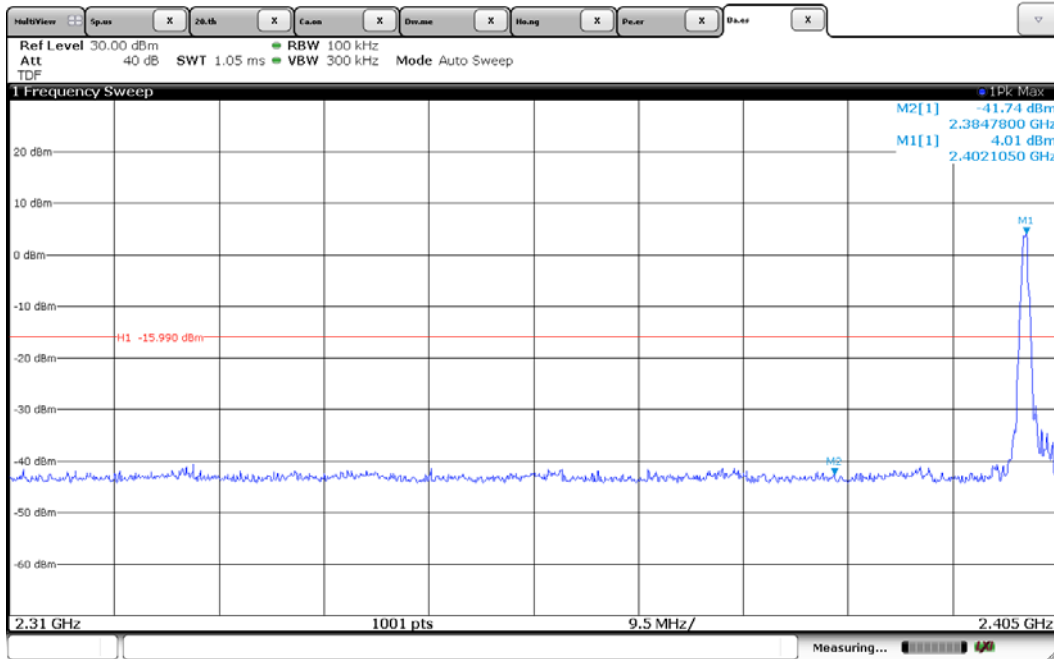

Radiated

Peak Detector: RBW: 1 MHz, VBW: 1 MHz (2 310 MHz - 2 390 MHz), Worst case (Low, Vertical)

— Peak Limit Line
— AV Limit Line

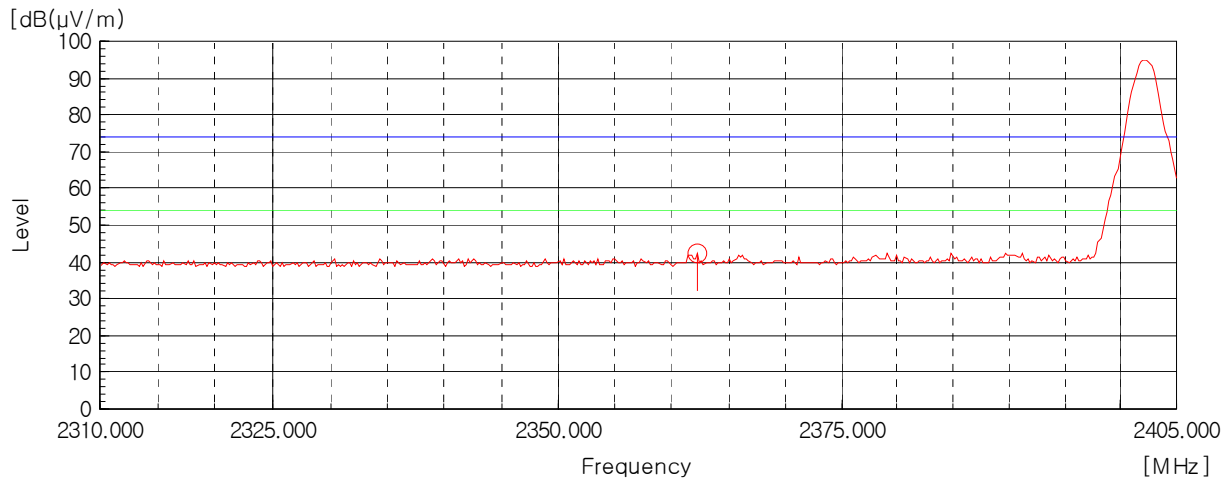

AV Detector: RBW: 1 MHz, VBW: 10 Hz (2 310 MHz - 2 390 MHz), Worst case (Low, Vertical)

— Peak Limit Line
— AV Limit Line

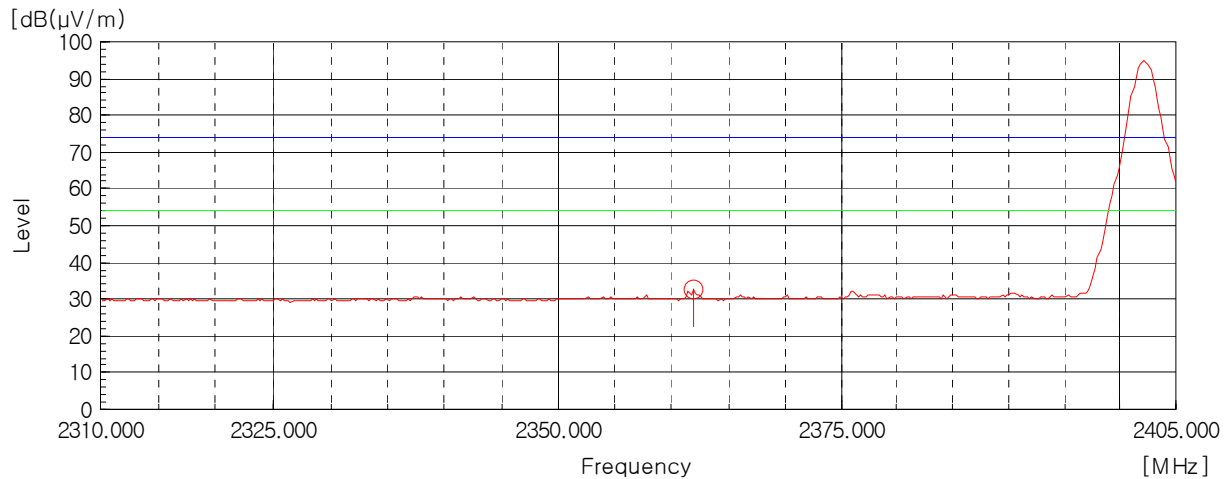

Peak Detector: RBW: 1 MHz, VBW: 1 MHz (2 483.5 MHz - 2 500.0 MHz), Worst case (High, Vertical)

— Peak Limit Line
 — AV Limit Line

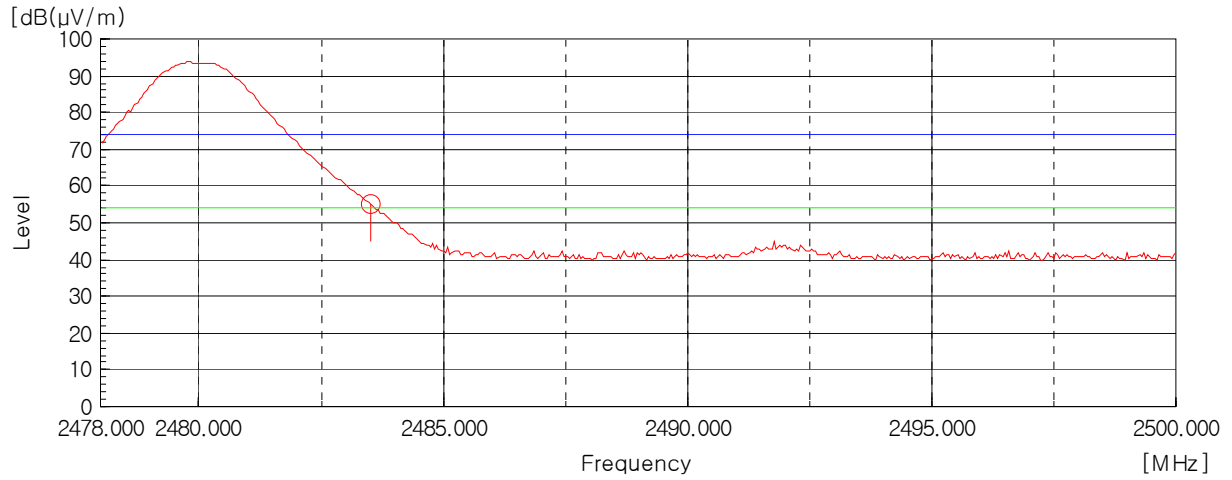

AV Detector: RBW: 1 MHz, VBW: 10 Hz (2 483.5 MHz - 2 500.0 MHz), Worst case (High, Vertical)

— Peak Limit Line
 — AV Limit Line

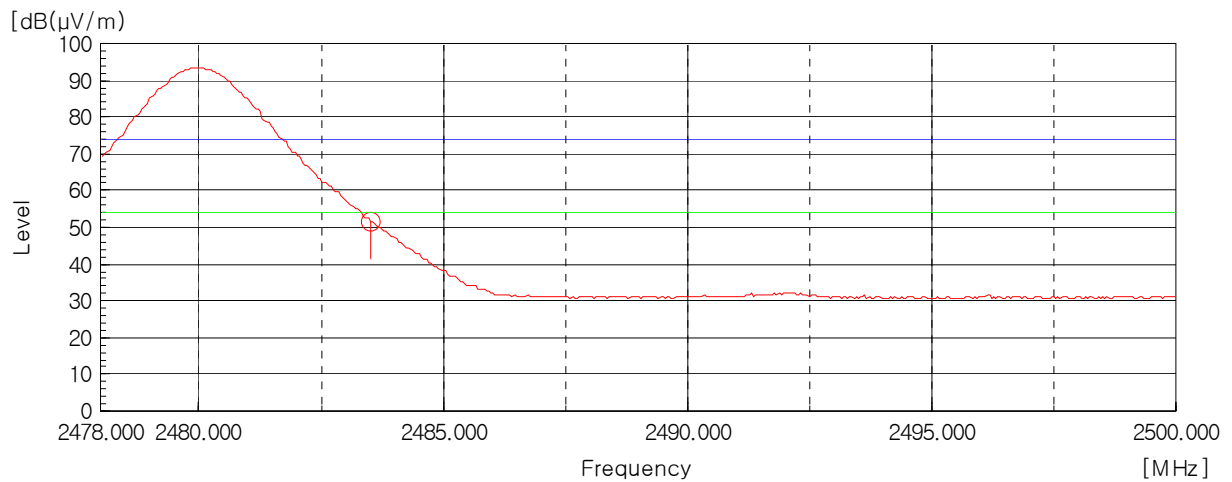

Plots of Bandwidth of Frequency Band Edges (EDR)

[Non-hopping mode]

Conducted

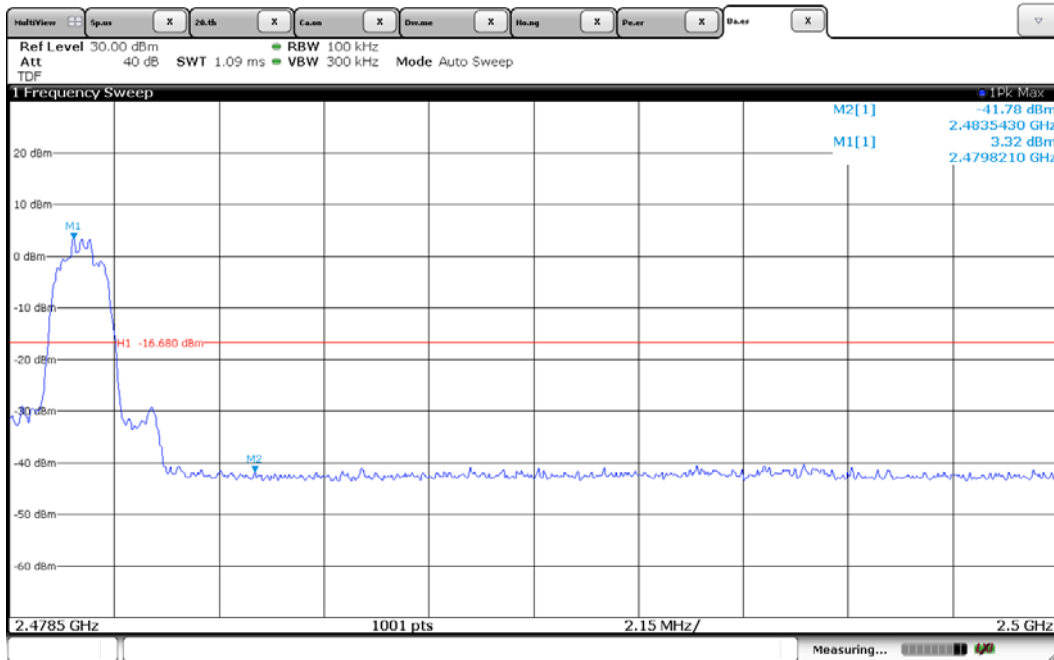
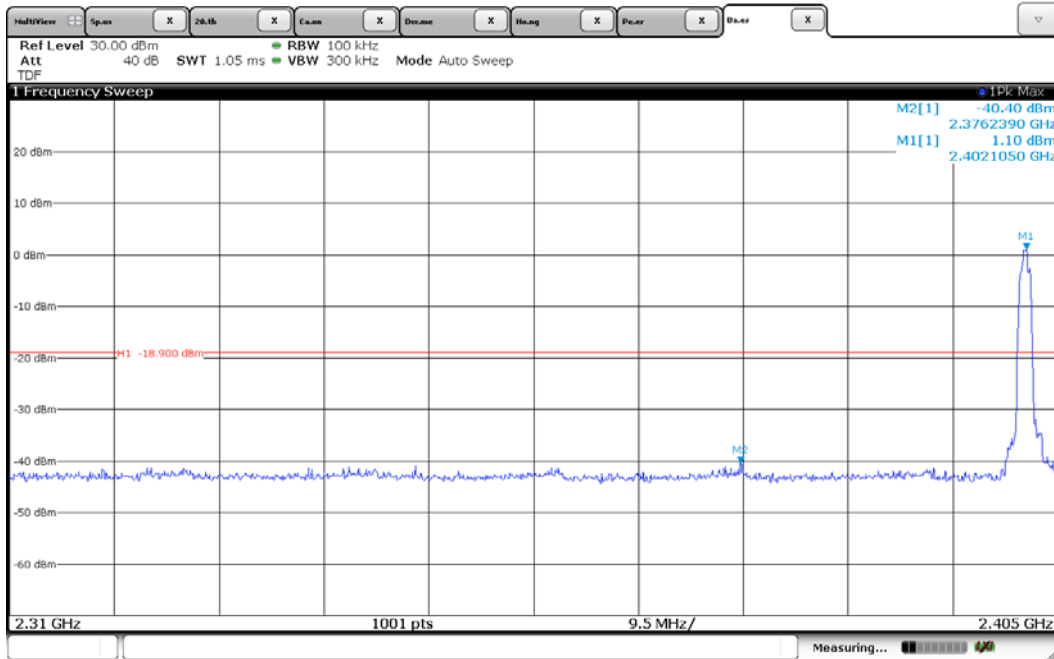

Radiated

Peak Detector: RBW: 1 MHz, VBW: 1 MHz (2 310 MHz - 2 390 MHz), Worst case (Low, Vertical)

— Peak Limit Line
 — AV Limit Line

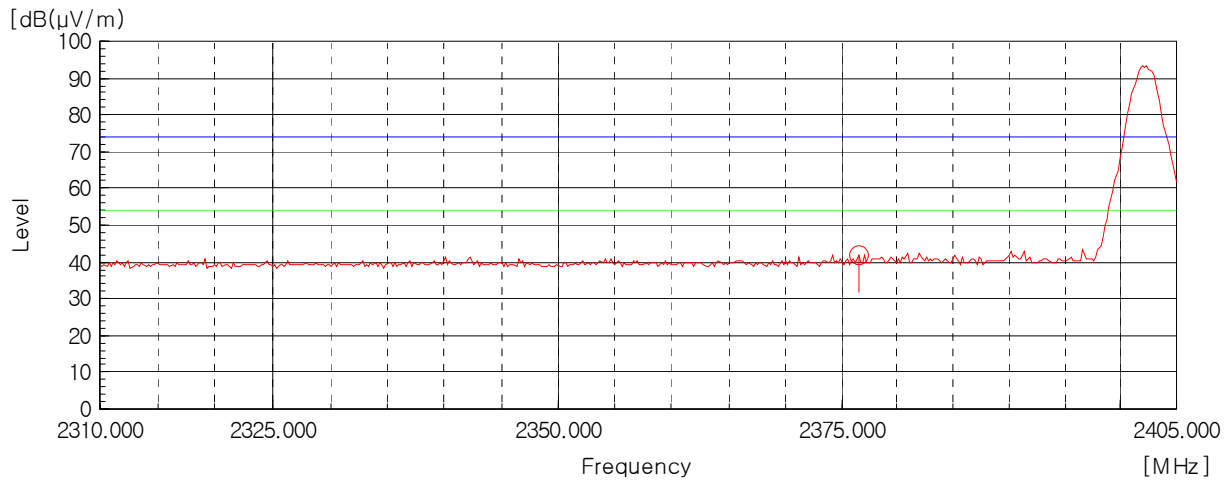

AV Detector: RBW: 1 MHz, VBW: 10 Hz (2 310 MHz - 2 390 MHz), Worst case (Low, Vertical)

— Peak Limit Line
 — AV Limit Line

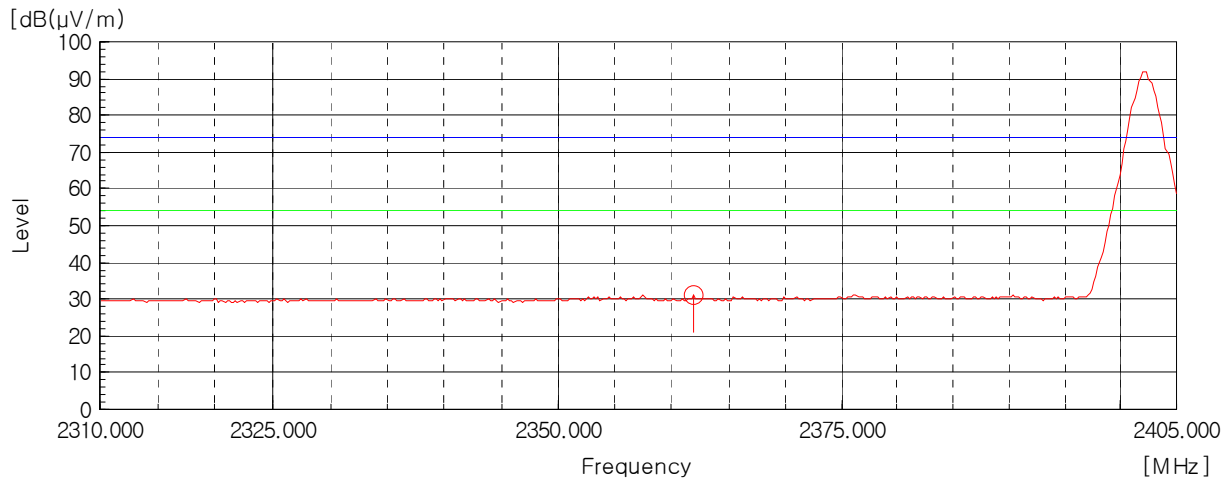

Peak Detector: RBW: 1 MHz, VBW: 1 MHz (2 483.5 MHz - 2 500.0 MHz), Worst case (High, Vertical)

— Peak Limit Line
— AV Limit Line

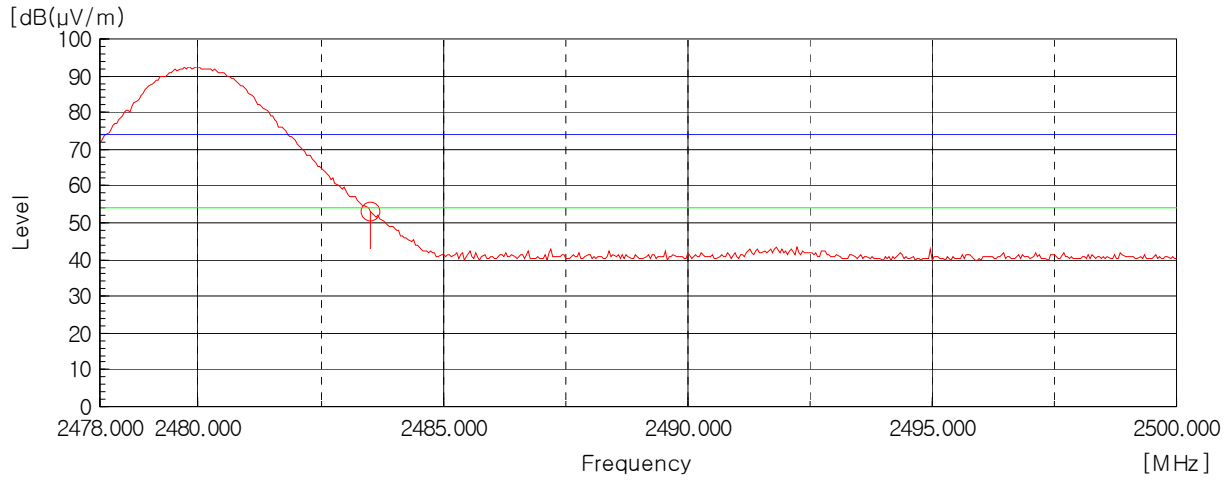

AV Detector: RBW: 1 MHz, VBW: 10 Hz (2 483.5 MHz - 2 500.0 MHz), Worst case (High, Vertical)

— Peak Limit Line
— AV Limit Line

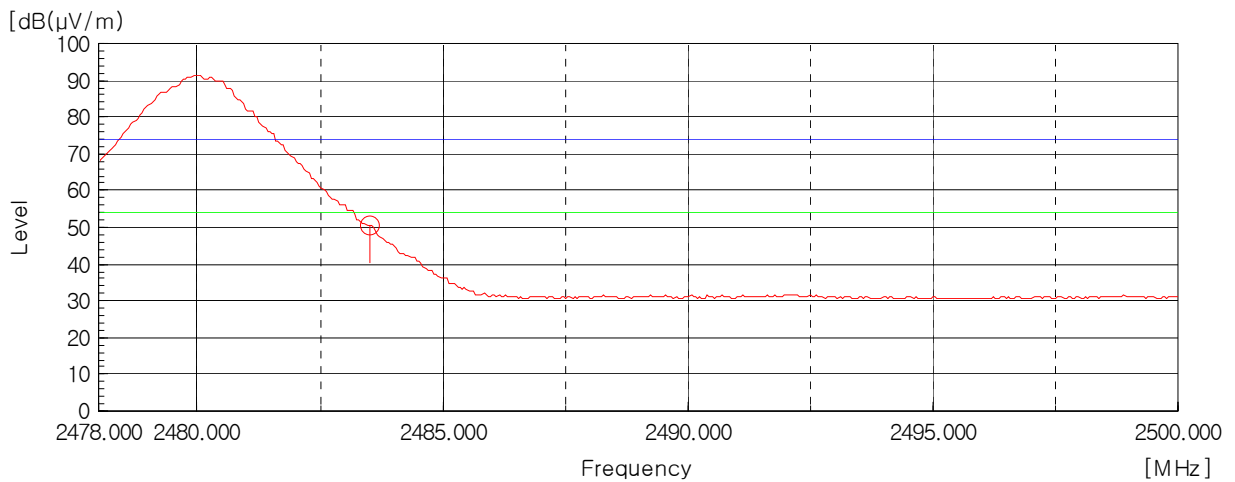

Radiated

Peak Detector: RBW: 1 MHz, VBW: 1 MHz (2 310 MHz - 2 390 MHz), Worst case (Low, Vertical)

— Peak Limit Line
— AV Limit Line

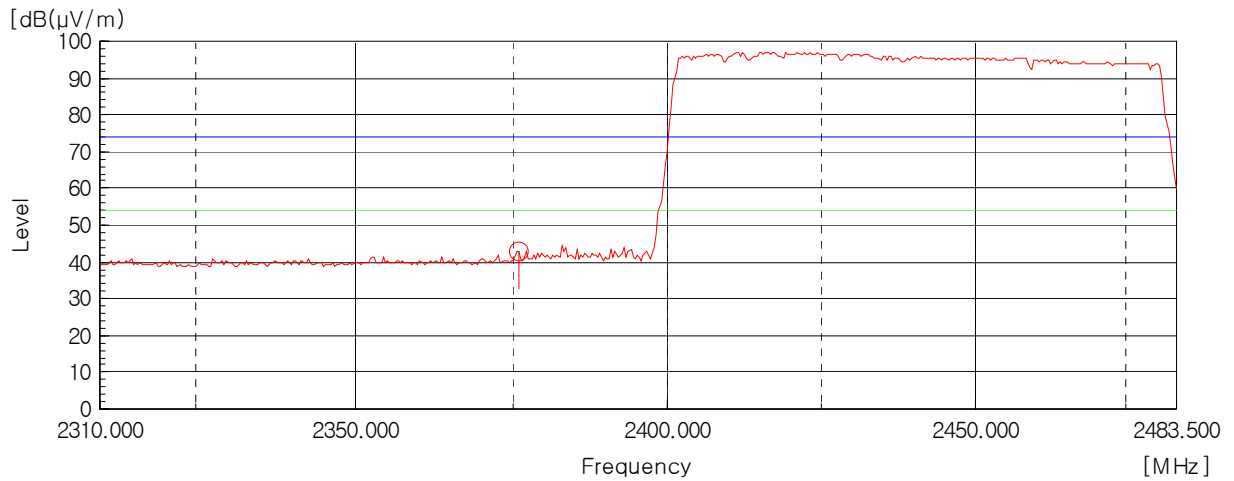

AV Detector: RBW: 1 MHz, VBW: 10 Hz (2 310 MHz - 2 390 MHz), Worst case (Low, Vertical)

— Peak Limit Line
— AV Limit Line

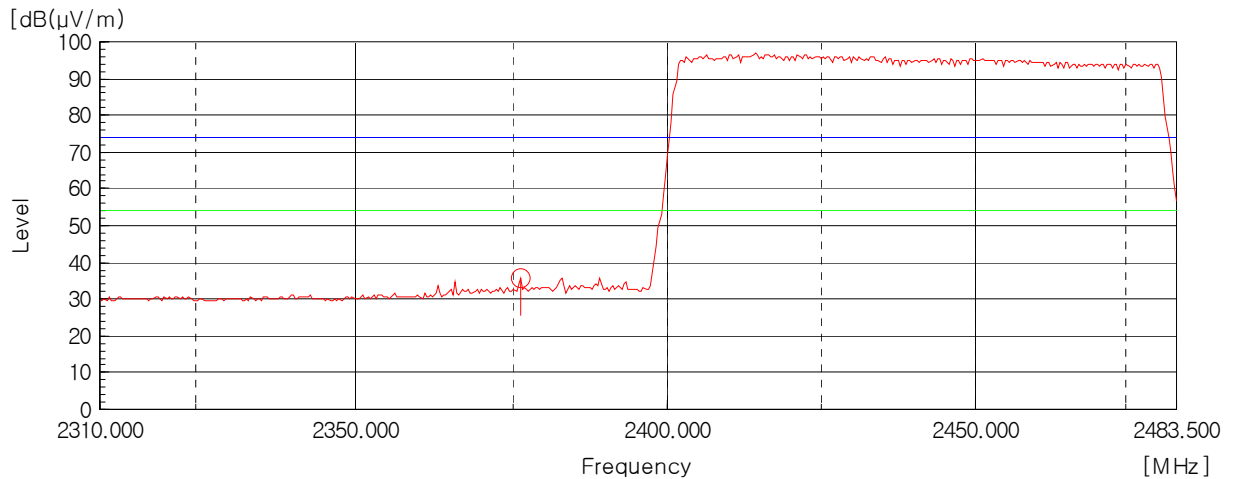

Peak Detector: RBW: 1 MHz, VBW: 1 MHz (2 483.5 MHz - 2 500.0 MHz), Worst case (High, Vertical)

— Peak Limit Line
 — AV Limit Line

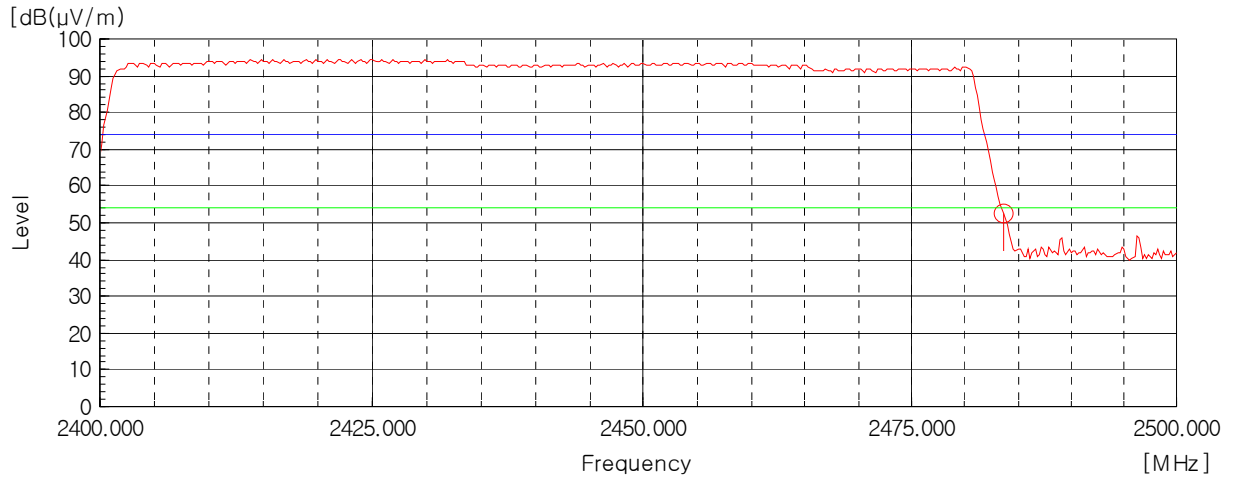

AV Detector: RBW: 1 MHz, VBW: 10 Hz (2 483.5 MHz - 2 500.0 MHz), Worst case (High, Vertical)

— Peak Limit Line
 — AV Limit Line

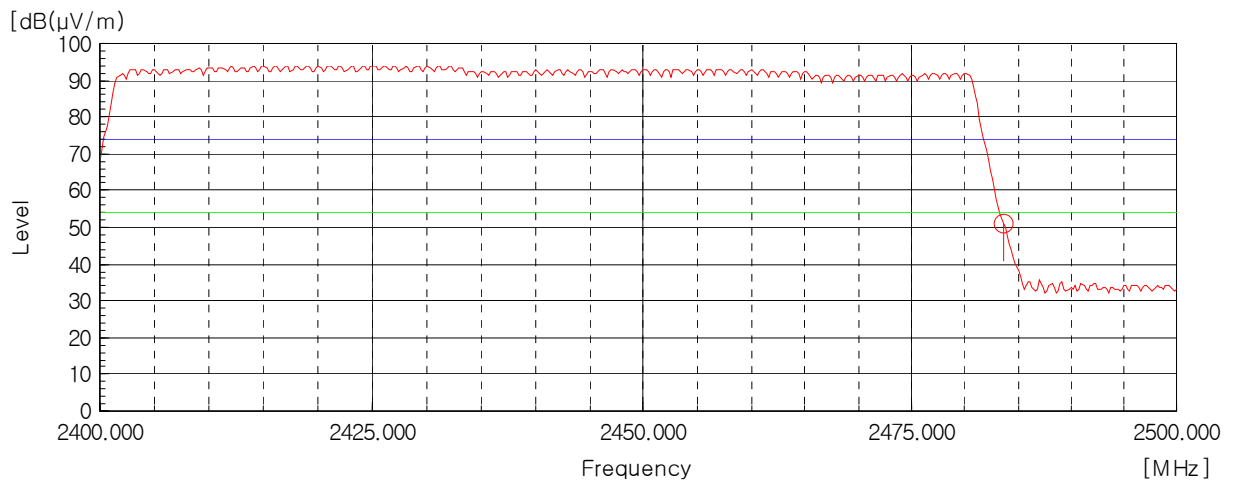

Radiated

Peak Detector: RBW: 1 MHz, VBW: 1 MHz (2 310 MHz - 2 390 MHz), Worst case (Low, Vertical)

— Peak Limit Line
 — AV Limit Line

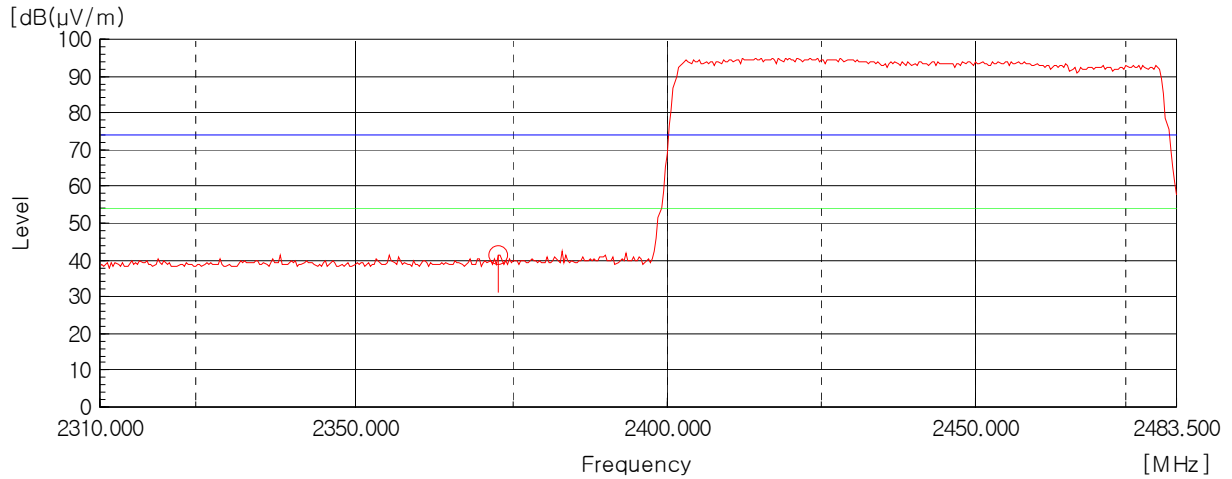

AV Detector: RBW: 1 MHz, VBW: 10 Hz (2 310 MHz - 2 390 MHz), Worst case (Low, Vertical)

— Peak Limit Line
 — AV Limit Line

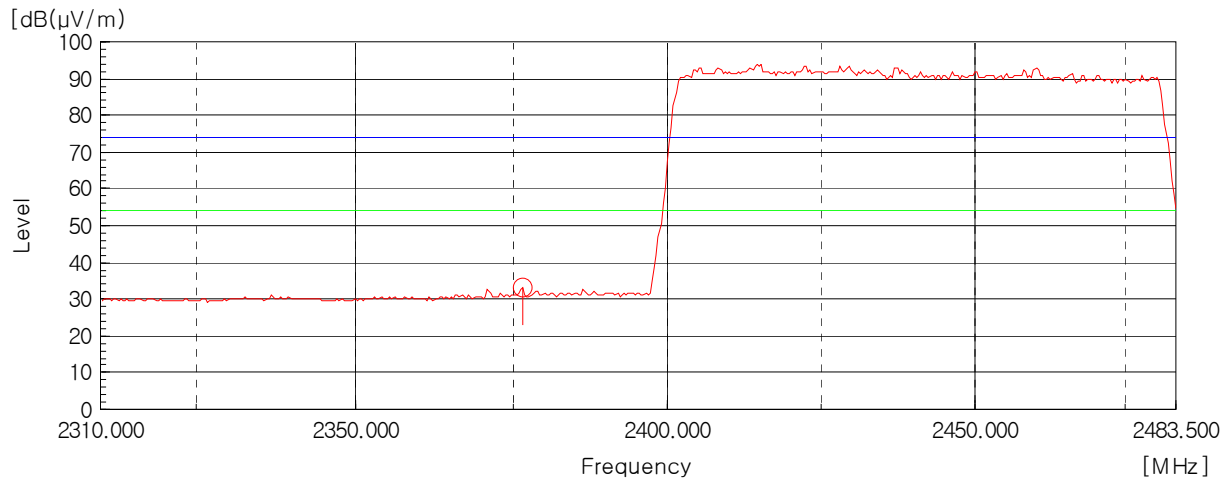

Peak Detector: RBW: 1 MHz, VBW: 1 MHz (2 483.5 MHz - 2 500.0 MHz), Worst case (High, Vertical)

— Peak Limit Line
 — AV Limit Line

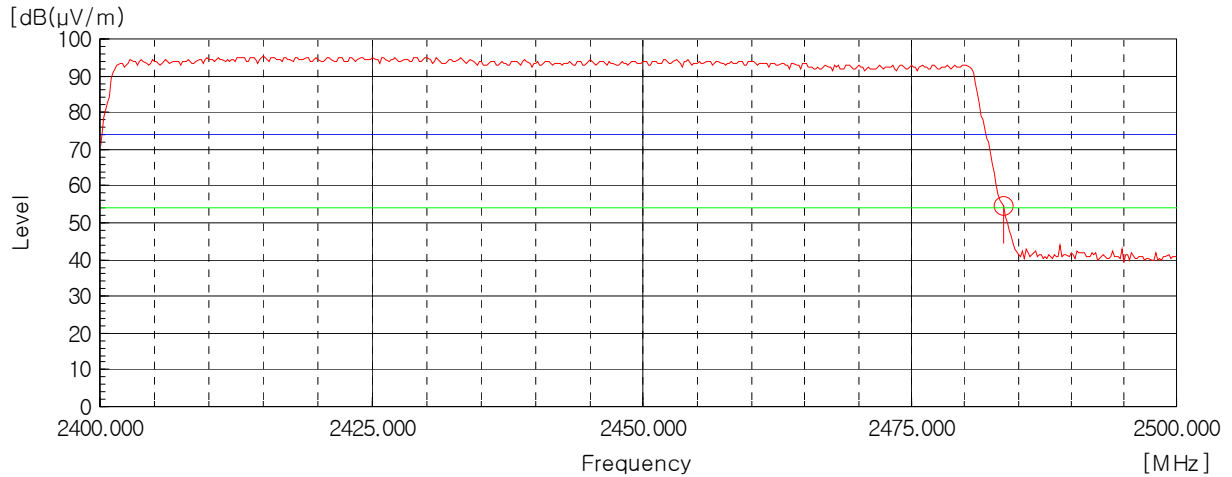

AV Detector: RBW: 1 MHz, VBW: 10 Hz (2 483.5 MHz - 2 500.0 MHz), Worst case (High, Vertical)

— Peak Limit Line
 — AV Limit Line

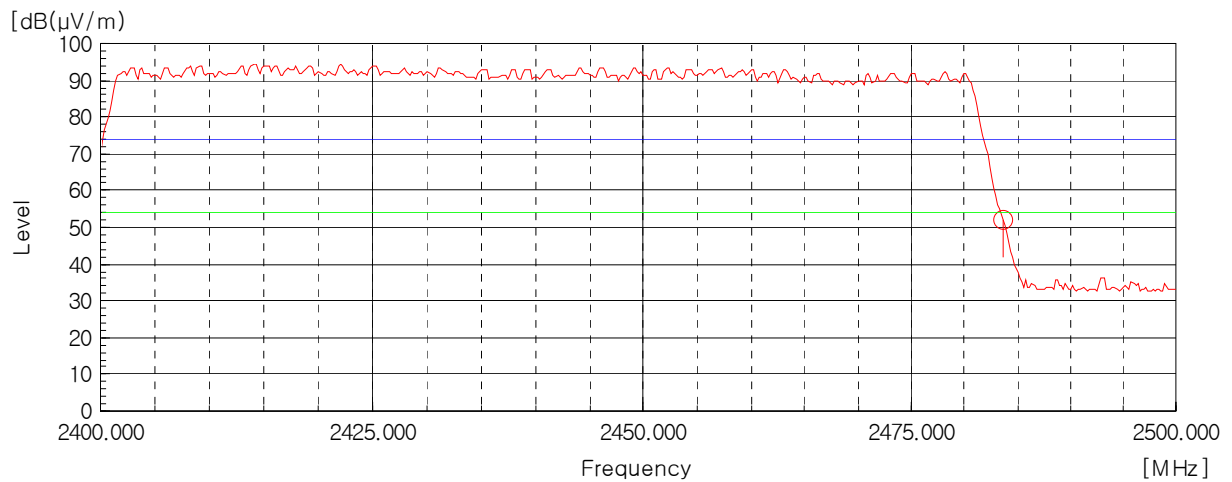

5.5 Number of Hopping Channels

EUT	HP Sprocket Photo Printer / SNPRH-1603
Limit apply to	FCC Part 15.247(a)(1)(iii)
Test Date	August 04, 2016
Environmental of Test	(23.3 ± 0.0) °C, (47 ± 0) % R.H., (100.9 ± 0.0) kPa
Operating Condition	RF transmitting continuously during the tested.
Result	Passed

Limit

Frequency hopping systems in the 2 400.0 MHz - 2 483.5 MHz band shall use at least 15 channels.

Test Data

Type of Modulation	Result	Limit
BDR	79	> 15 Channel
EDR	79	

NOTES:

1. Measure number of hopping channel of relevant channel using spectrum analyzer.
2. Please see the measured plot in next page.

Plots of Number of Hopping Channels (BDR)

[Hopping Channels]

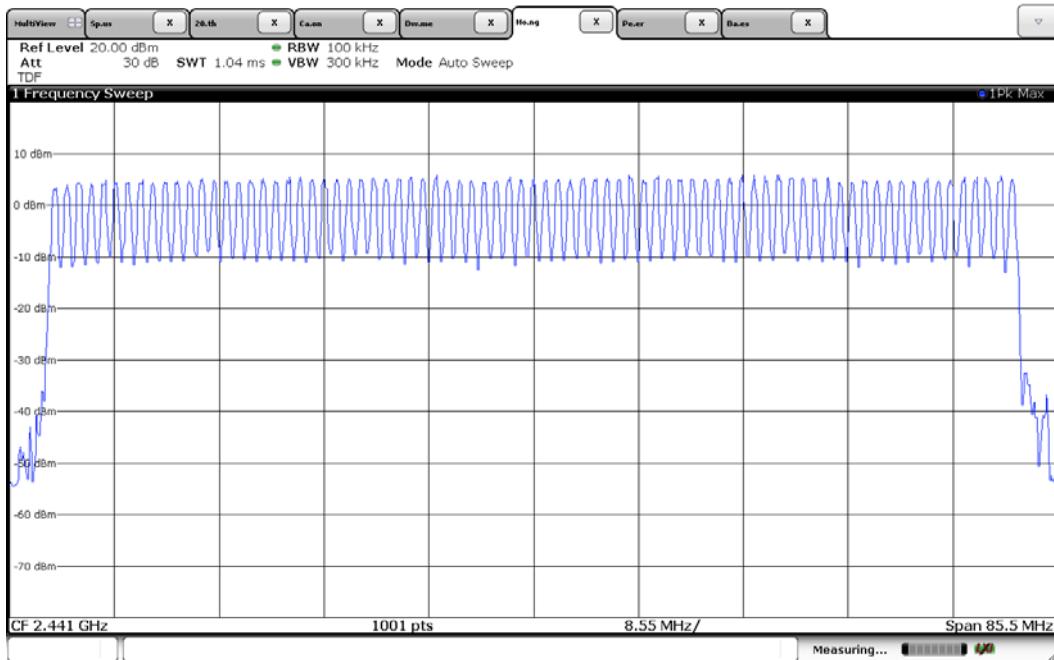

Plots of Number of Hopping Channels (EDR)

[Hopping Channels]

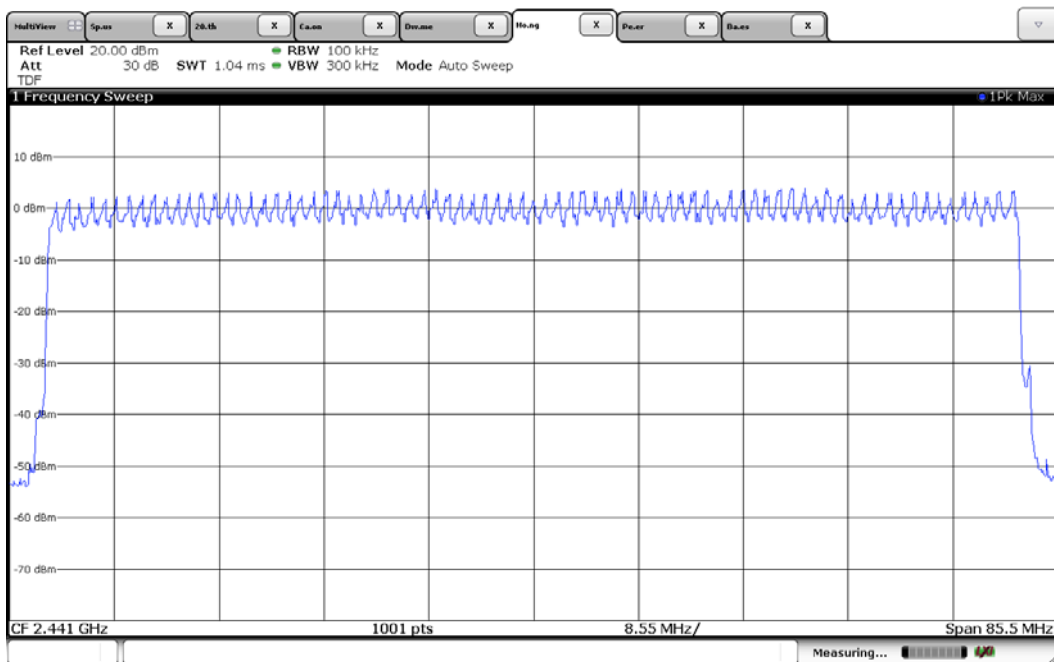

5.6 Time of Occupancy

EUT	HP Sprocket Photo Printer / SNPRH-1603
Limit apply to	FCC Part 15.247(a)(1)(iii)
Test Date	August 04, 2016
Environmental of Test	(23.2 ± 0.0) °C, (47 ± 0) % R.H., (100.9 ± 0.0) kPa
Operating Condition	RF transmitting continuously during the tested.
Result	Passed

Limit

Frequency hopping systems in the 2 400.0 MHz - 2 483.5 MHz band. The average time of occupancy on any channel shall not be greater than 0.4 seconds within a period of 0.4 seconds multiplied by the number of hopping channels employed.

Test Data

Time of Occupancy

Test period = 0.4 [seconds/channel] x 79 [channel]

Actual = Reading x (Hopping rate/Number of channels) x Test period

- Hopping rate (DH5 Packet) = 1 600 [hopping/second] / 6 [time slot] = 266.667

- Hopping rate (3DH5 Packet) = 1 600 [hopping/second] / 6 [time slot] = 266.667

- Type of Modulation: BDR

0.4 s x 79 (CH) = 31.6 s

2.892 ms x (266.667/79) x 31.6 s = 308.480 ms

- Type of Modulation: EDR

0.4 s x 79 (CH) = 31.6 s

2.872 ms x (266.667/79) x 31.6 s = 306.347 ms

Type of Modulation	Pulse Time [ms]	Total of Dwell [ms]	Limit [ms]
BDR	2.892	308.480	400.000
EDR	2.872	306.347	400.000

NOTES:

1. BDR: This test was applied both to DH1, DH3 and DH5. (Worst case: DH5)
2. EDR: This test was applied both to 2DH1, 2DH3, 2DH5, 3DH1, 3DH3 and 3DH5. (Worst case: 3DH5)
3. Measure time of occupancy of relevant channel using spectrum analyzer.
4. Please see the measured plot in next page.

Plots of Time of Occupancy (BDR)

[Continuous Time]

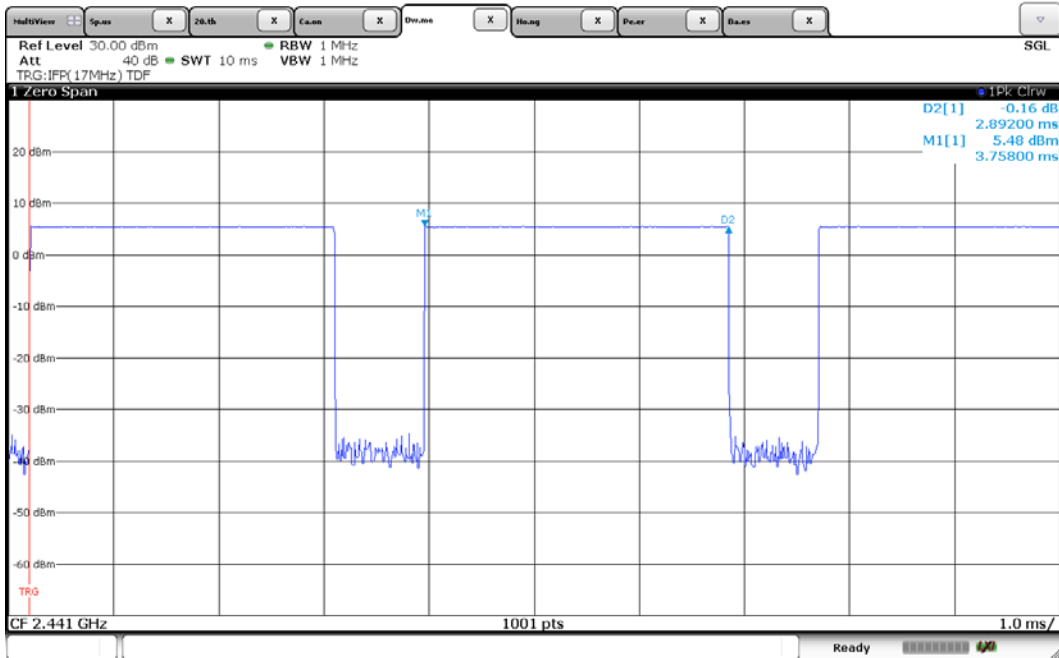

[Hopping Period]

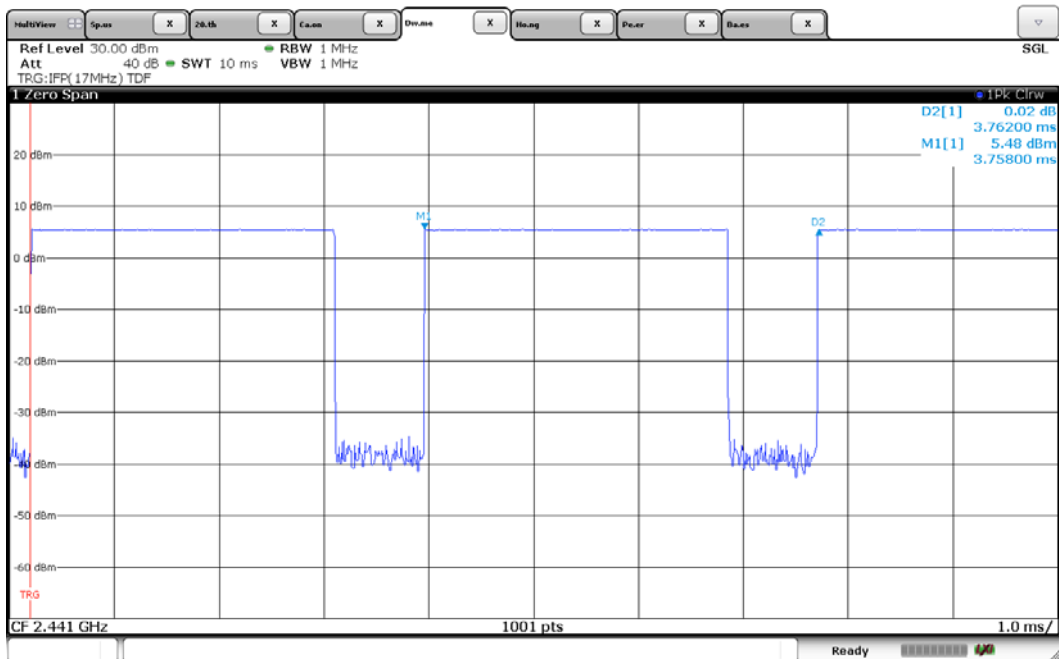

Plots of Time of Occupancy (EDR)

[Continuous Time]

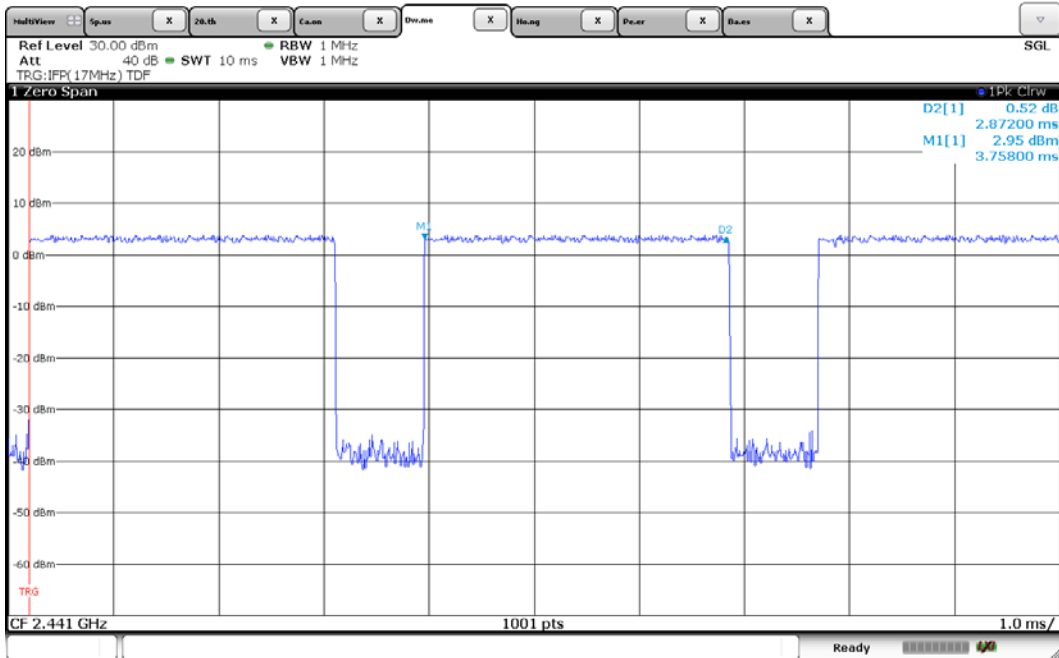

[Hopping Period]

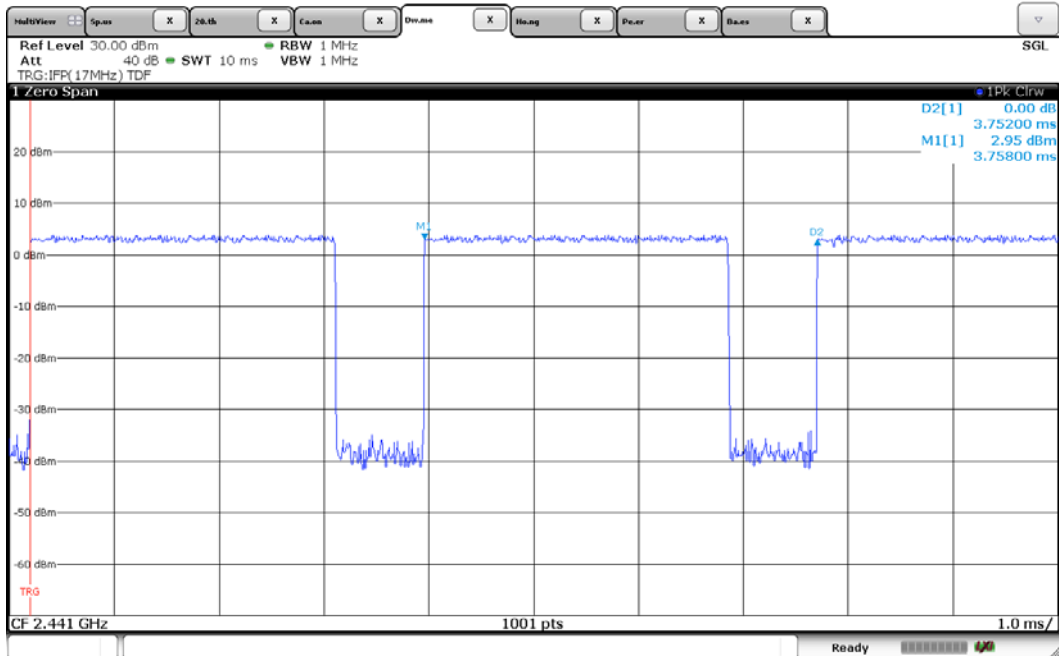

5.7 Spurious Emissions

EUT	HP Sprocket Photo Printer / SNPRH-1603
Limit apply to	FCC Part 15.209
Operating Condition	Low CH, Middle CH, High CH Transmission
Result	Passed

Limit

Except as provided elsewhere in this Subpart, the emissions from an intentional radiator shall not exceed the field strength levels specified in the following table:

Frequencies [MHz]	Field Strength [μ V/m]	Measurement Distance [m]
0.009 - 0.490	2 400/F(kHz)	300
0.490 - 1.705	24 000/F(kHz)	30
1.705 - 30.0	30	30
30 - 88	100	3
88 - 216	150	3
216 - 960	200	3
Above 960	500	3

* Except as provided in paragraph (g), fundamental emissions from intentional radiators operating under this Section shall not be located in the frequency bands 54 MHz - 72 MHz, 76 MHz - 88 MHz, 174 MHz - 216 MHz or 470 MHz - 806 MHz. However, operation within these frequency bands is permitted under other sections of this Part, e.g., Sections 15.231 and 15.241.

Test Results

- Refer to see the measured plot in next page.

Radiated Emissions Test data

- 9 kHz to 30 MHz

Test Date	August 11, 2016
Environmental of Test	(35.0 ± 0.3) °C, (68 ± 1) % R.H., (101.0 ± 0.0) kPa

The following table shows the highest levels of radiated emissions on both polarizations of horizontal and vertical.
 Detector mode: CISPR Quasi-Peak mode (100 Hz, 9 kHz)

- Type of Modulation: BDR, EDR

Frequency [MHz]	Reading [dB(μV)]	Polarization (*H/**V)	Ant. Factor [dB/m]	Cable Loss + Amp. Gain [dB]	Result [dB(μV/m)]	Limit [dB(μV/m)]	Margin [dB]
	Emission attenuated more than 20 dB below the limit are not reported.						

Result: All emissions below noise floor of 20 dB(μV/m).

NOTES:

1. * H : Horizontal polarization , ** V : Vertical polarization
2. Result = Reading + Antenna factor + Cable loss
3. Margin = Limit - Result
4. The measurement was performed for the frequency range 9 kHz to 30 MHz according to FCC Part 15.209.

- Below 1 GHz (30 MHz to 1 GHz)

Test Date	August 11, 2016
Environmental of Test	(35.0 ± 0.2) °C, (69 ± 1) % R.H., (101.0 ± 0.0) kPa

The following table shows the highest levels of radiated emissions on both polarizations of horizontal and vertical. Detector mode: CISPR Quasi-Peak mode (6 dB Bandwidth: 120 kHz)

- Type of Modulation: BDR (Worst case)

Frequency [MHz]	Reading [dB(μV)]	Polarization (*H/**V)	Ant. Factor [dB/m]	Cable Loss [dB]	Height [cm]	Result [dB(μV/m)]	Limit [dB(μV/m)]	Margin [dB]
41.59	49.50	V	12.93	-30.77	105	31.66	40.00	8.34
53.18	47.70	V	12.95	-30.56	111	30.09	40.00	9.91
156.12	53.00	H	13.13	-29.48	378	36.65	43.50	6.85
168.40	50.20	H	12.48	-29.31	380	33.37	43.50	10.13
407.82	45.20	H	16.11	-27.11	105	34.20	46.00	11.80
427.26	44.10	H	16.55	-26.95	117	33.70	46.00	12.30

NOTES:

- * H : Horizontal polarization , ** V : Vertical polarization
- The cable loss value was included the Amp. Gain.
- Result = Reading + Antenna factor + Cable loss
- Margin value = Limit - Result
- The measurement was performed for the frequency range above 30 MHz according to FCC Part 15.209.

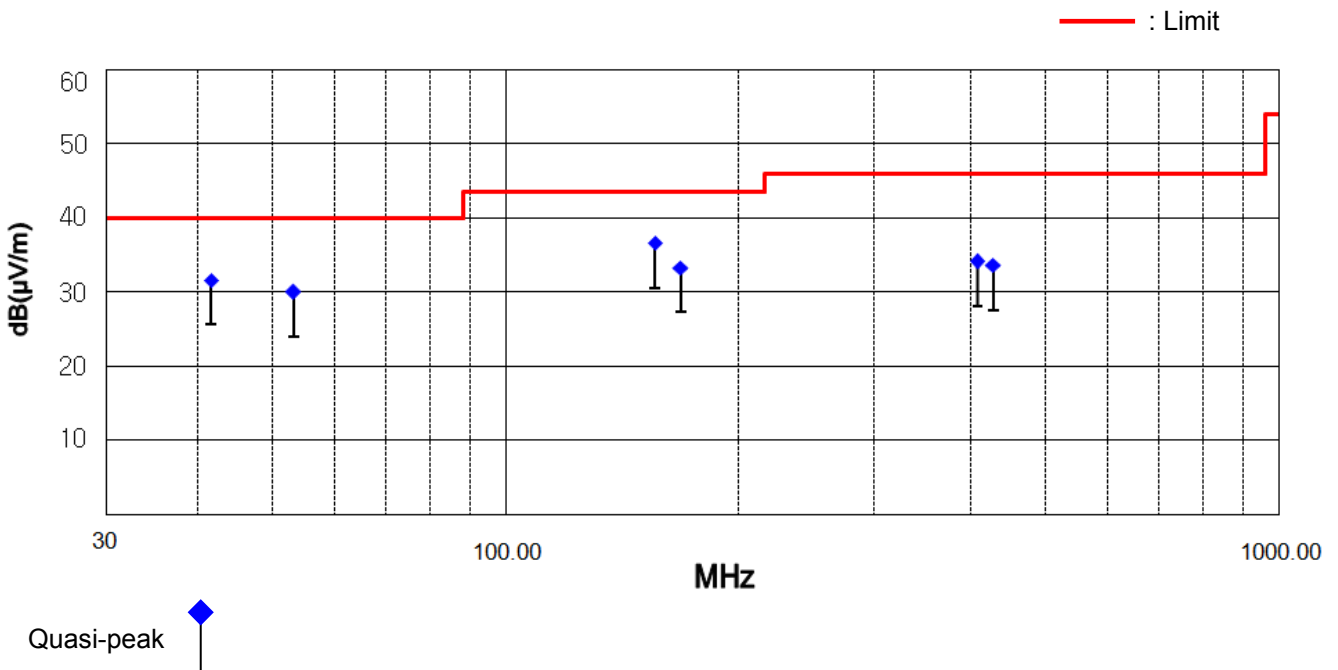

- Above 1 GHz (1 GHz to 25 GHz)

Test Date	August 05, 2016
Environmental of Test	(23.6 ± 0.3) °C, (48 ± 0) % R.H., (100.8 ± 0.0) kPa

- Type of Modulation: BDR

1. Low CH

Frequency [MHz]	Reading [dB(μV)]		Polarity (*H/**V)	Ant. Factor [dB/m]	Cable +AMP Loss [dB]	Result [dB(μV/m)]		Limit [dB(μV/m)]		Margin [dB]	
	Peak	Average				Peak	Average	Peak	Average	Peak	Average
1 553.48	55.54	42.54	V	25.68	-38.02	43.20	30.20	73.97	53.97	30.77	23.77
1 597.92	55.61	38.81	V	25.73	-37.94	43.40	26.60	73.97	53.97	30.57	27.37
1 997.88	55.91	38.91	V	26.18	-37.19	44.90	28.40	73.97	53.97	29.07	25.57
2 450.36	53.56	39.16	V	27.27	-35.93	44.90	30.50	73.97	53.97	29.07	23.47
2 854.36	53.98	49.18	V	28.28	-35.46	46.80	42.00	73.97	53.97	27.17	11.97
3 003.84	58.08	55.58	V	28.65	-35.33	51.40	48.90	73.97	53.97	22.57	5.07

2. Middle CH

Frequency [MHz]	Reading [dB(μV)]		Polarity (*H/**V)	Ant. Factor [dB/m]	Cable +AMP Loss [dB]	Result [dB(μV/m)]		Limit [dB(μV/m)]		Margin [dB]	
	Peak	Average				Peak	Average	Peak	Average	Peak	Average
1 597.92	54.01	38.51	V	25.73	-37.94	41.80	26.30	73.97	53.97	32.17	27.67
1 727.20	56.53	42.33	V	25.87	-37.70	44.70	30.50	73.97	53.97	29.27	23.47
1 981.72	55.66	39.06	V	26.16	-37.22	44.60	28.00	73.97	53.97	29.37	25.97
2 551.36	54.42	49.62	V	27.52	-35.74	46.20	41.40	73.97	53.97	27.77	12.57
2 854.36	55.28	50.88	V	28.28	-35.46	48.10	43.70	73.97	53.97	25.87	10.27
3 003.84	59.18	55.38	V	28.65	-35.33	52.50	48.70	73.97	53.97	21.47	5.27

3. High CH

Frequency [MHz]	Reading [dB(μV)]		Polarity (*H/**V)	Ant. Factor [dB/m]	Cable +AMP Loss [dB]	Result [dB(μV/m)]		Limit [dB(μV/m)]		Margin [dB]	
	Peak	Average				Peak	Average	Peak	Average	Peak	Average
1 597.92	56.41	38.21	V	25.73	-37.94	44.20	26.00	73.97	53.97	29.77	27.97
1 727.20	55.33	42.93	V	25.87	-37.70	43.50	31.10	73.97	53.97	30.47	22.87
1 985.76	54.86	39.36	V	26.16	-37.22	43.80	28.30	73.97	53.97	30.17	25.67
2 482.68	54.99	47.09	H	27.35	-35.84	46.50	38.60	73.97	53.97	27.47	15.37
2 850.32	54.79	50.99	V	28.27	-35.46	47.60	43.80	73.97	53.97	26.37	10.17
3 003.84	58.68	56.08	V	28.65	-35.33	52.00	49.40	73.97	53.97	21.97	4.57

NOTES:

1. * H : Horizontal polarization , ** V : Vertical polarization
2. Factor = Antenna factor + Cable loss + Preamp
3. Result = Reading + Factor
4. Margin value = Limit - Result
5. Measuring frequencies from 1 GHz to the 10th harmonic of highest fundamental frequency.
6. Measurements above show only up to 6 maximum emissions noted, or would be lesser if no specific emissions from the EUT are recorded (ie: margin > 20 dB from the applicable limit) and considered that's already beyond the background noise floor.
7. Spectrum setting:
 - a. Peak Setting 1 GHz to 10th harmonics of fundamental, RBW = 1 MHz, VBW = 1 MHz, Sweep = Auto
 - b. AV Setting 1 GHz to 10th harmonics of fundamental, RBW = 1 MHz, VBW = 10 kHz, Sweep = Auto

- Type of Modulation: EDR

1. Low CH

Frequency [MHz]	Reading [dB(μV)]		Polarity (*H/**V)	Ant. Factor [dB/m]	Cable +AMP Loss [dB]	Result [dB(μV/m)]		Limit [dB(μV/m)]		Margin [dB]	
	Peak	Average				Peak	Average	Peak	Average	Peak	Average
1 549.44	57.65	38.35	H	25.68	-38.03	45.30	26.00	73.97	53.97	28.67	27.97
1 597.92	55.21	39.11	H	25.73	-37.94	43.00	26.90	73.97	53.97	30.97	27.07
1 727.20	55.23	42.33	V	25.87	-37.70	43.40	30.50	73.97	53.97	30.57	23.47
1 997.88	54.71	39.31	V	26.18	-37.19	43.70	28.30	73.97	53.97	30.27	25.67
2 854.36	53.78	48.88	V	28.28	-35.46	46.60	41.70	73.97	53.97	27.37	12.27
3 003.84	58.88	55.38	V	28.65	-35.33	52.20	48.70	73.97	53.97	21.77	5.27

2. Middle CH

Frequency [MHz]	Reading [dB(μV)]		Polarity (*H/**V)	Ant. Factor [dB/m]	Cable +AMP Loss [dB]	Result [dB(μV/m)]		Limit [dB(μV/m)]		Margin [dB]	
	Peak	Average				Peak	Average	Peak	Average	Peak	Average
1 553.48	54.74	39.34	V	25.68	-38.02	42.40	27.00	73.97	53.97	31.57	26.97
1 593.88	53.42	38.22	V	25.73	-37.95	41.20	26.00	73.97	53.97	32.77	27.97
1 993.84	53.73	39.13	V	26.17	-37.20	42.70	28.10	73.97	53.97	31.27	25.87
2 551.36	53.72	49.42	V	27.52	-35.74	45.50	41.20	73.97	53.97	28.47	12.77
2 854.36	53.88	49.68	V	28.28	-35.46	46.70	42.50	73.97	53.97	27.27	11.47
3 003.84	58.48	55.98	V	28.65	-35.33	51.80	49.30	73.97	53.97	22.17	4.67

3. High CH

Frequency [MHz]	Reading [dB(μV)]		Polarity (*H/**V)	Ant. Factor [dB/m]	Cable +AMP Loss [dB]	Result [dB(μV/m)]		Limit [dB(μV/m)]		Margin [dB]	
	Peak	Average				Peak	Average	Peak	Average	Peak	Average
1 553.48	57.04	42.64	V	25.68	-38.02	44.70	30.30	73.97	53.97	29.27	23.67
1 589.84	55.13	38.23	V	25.72	-37.95	42.90	26.00	73.97	53.97	31.07	27.97
1 989.80	53.84	38.44	V	26.17	-37.21	42.80	27.40	73.97	53.97	31.17	26.57
2 551.36	53.22	48.82	V	27.52	-35.74	45.00	40.60	73.97	53.97	28.97	13.37
2 854.36	53.38	49.18	V	28.28	-35.46	46.20	42.00	73.97	53.97	27.77	11.97
3 003.84	58.58	55.78	V	28.65	-35.33	51.90	49.10	73.97	53.97	22.07	4.87

NOTES:

1. * H : Horizontal polarization , ** V : Vertical polarization
2. Factor = Antenna factor + Cable loss + Preamp
3. Result = Reading + Factor
4. Margin value = Limit - Result
5. Measuring frequencies from 1 GHz to the 10th harmonic of highest fundamental frequency.
6. Measurements above show only up to 6 maximum emissions noted, or would be lesser if no specific emissions from the EUT are recorded (ie: margin > 20 dB from the applicable limit) and considered that's already beyond the background noise floor.
7. Spectrum setting:
 - a. Peak Setting 1 GHz to 10th harmonics of fundamental, RBW = 1 MHz, VBW = 1 MHz, Sweep = Auto
 - b. AV Setting 1 GHz to 10th harmonics of fundamental, RBW = 1 MHz, VBW = 10 kHz, Sweep = Auto

Test Date	August 04, 2016
Environmental of Test	(23.2 ± 0.2) °C, (46 ± 0) % R.H., (100.9 ± 0.0) kPa

Plots of Spurious Emissions (Conducted Measurement) (BDR)

[CH Low]

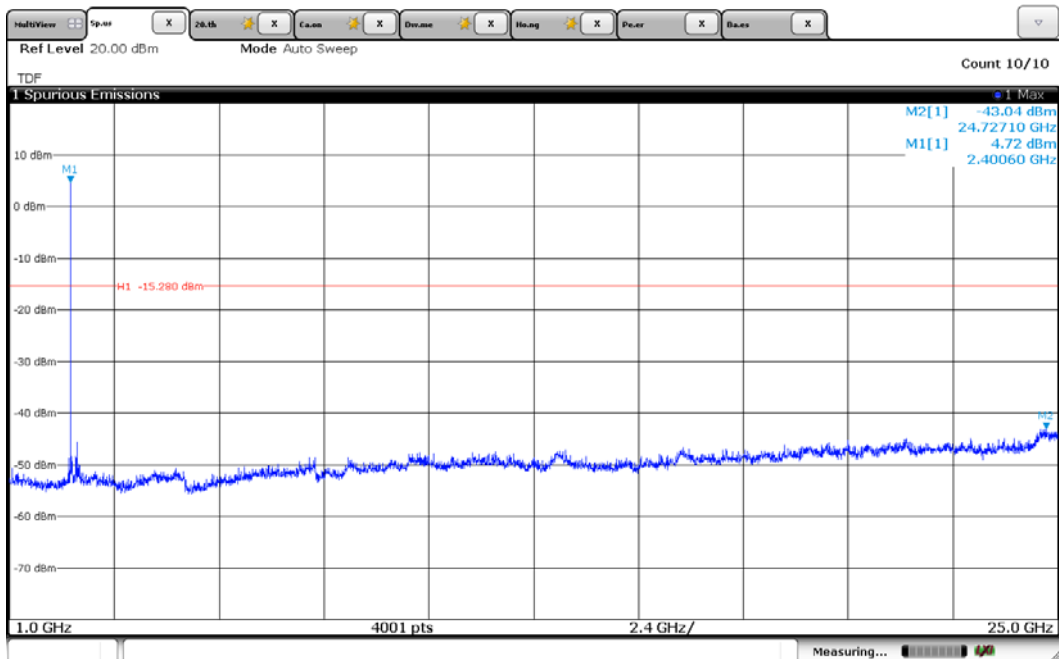
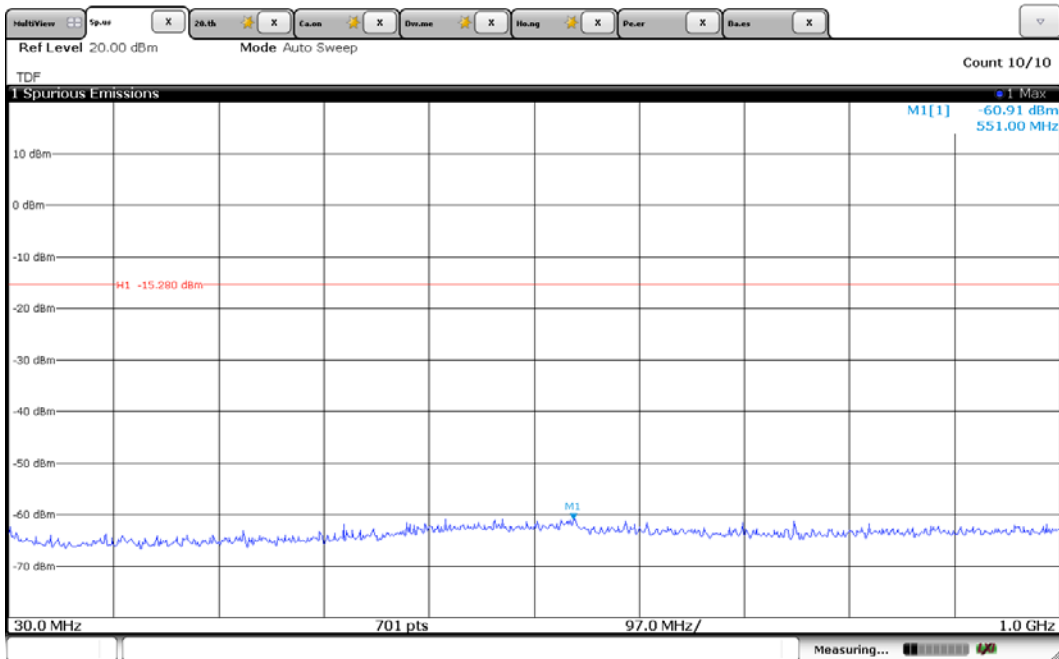

[CH Mid]

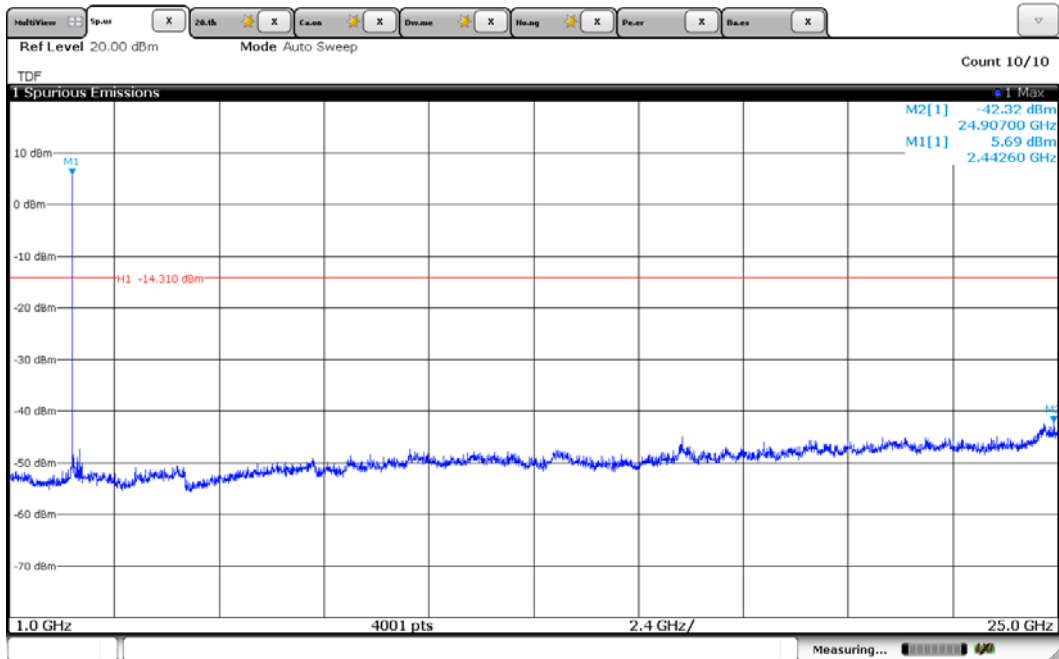
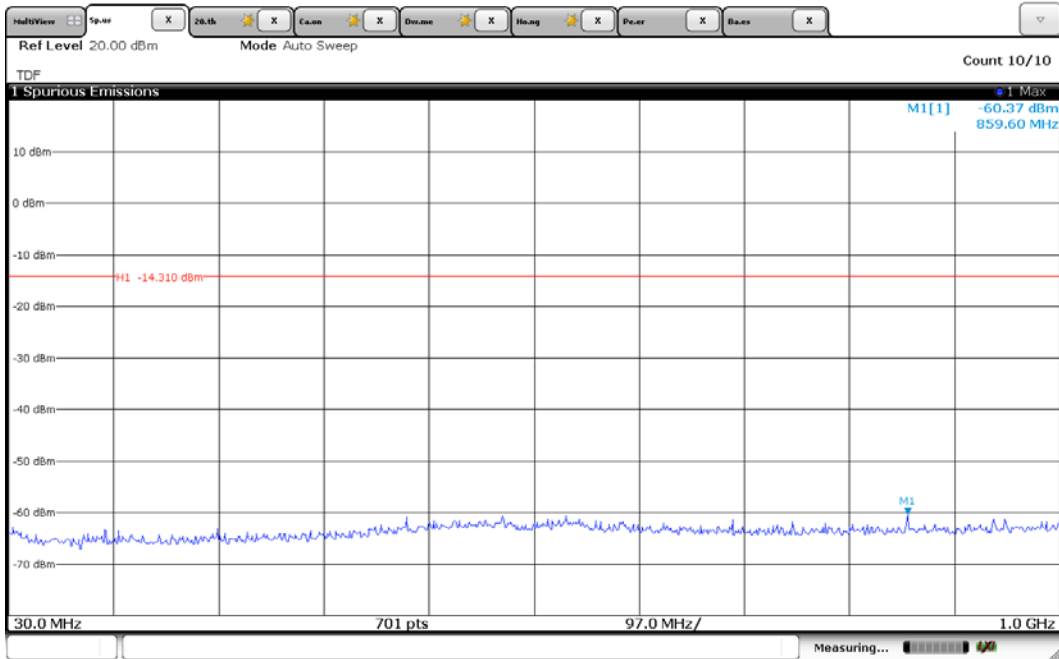

[CH High]

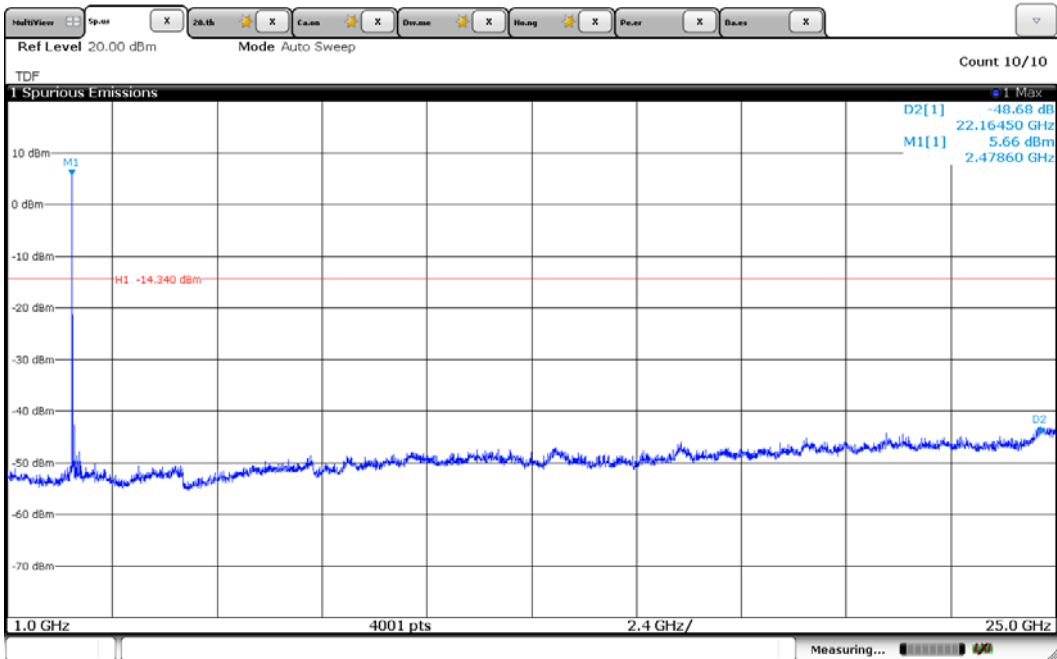
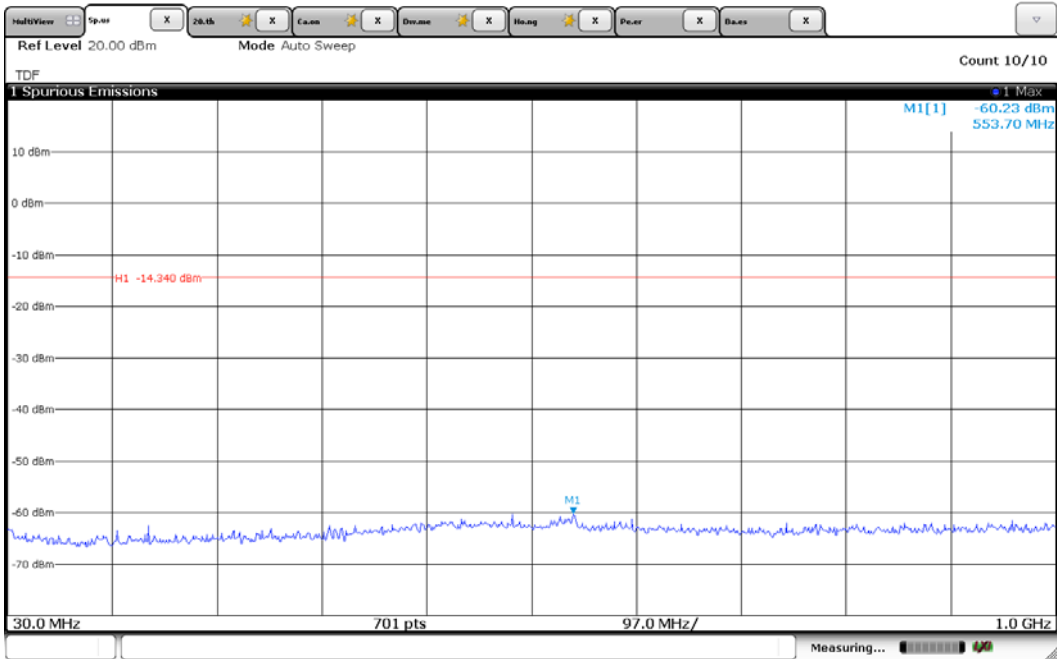

Plots of Spurious Emissions (Conducted Measurement) (EDR)

[CH Low]

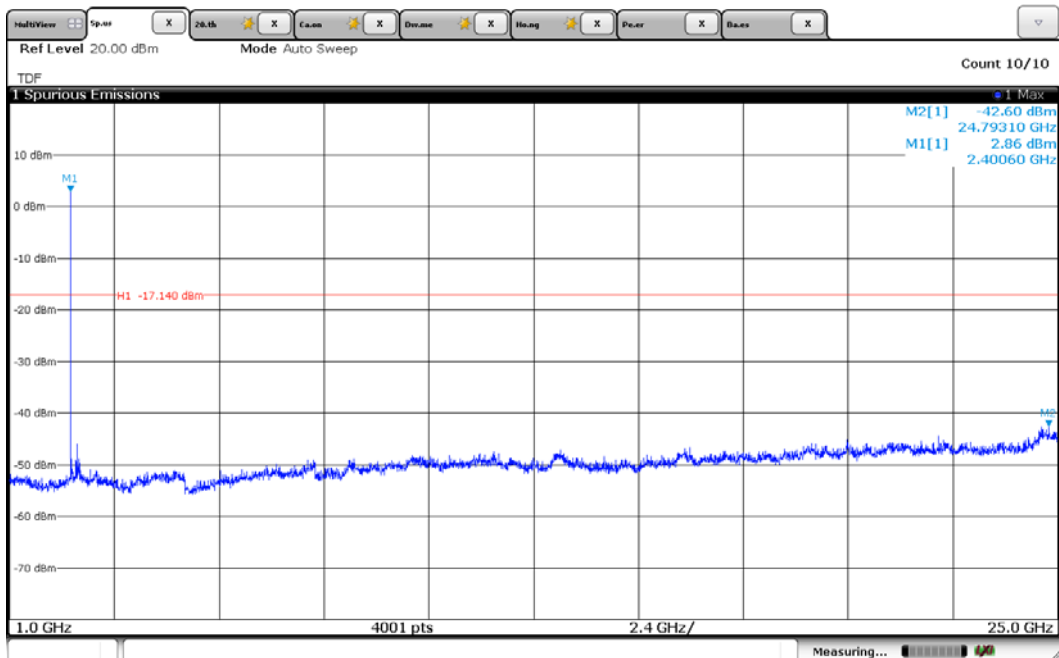
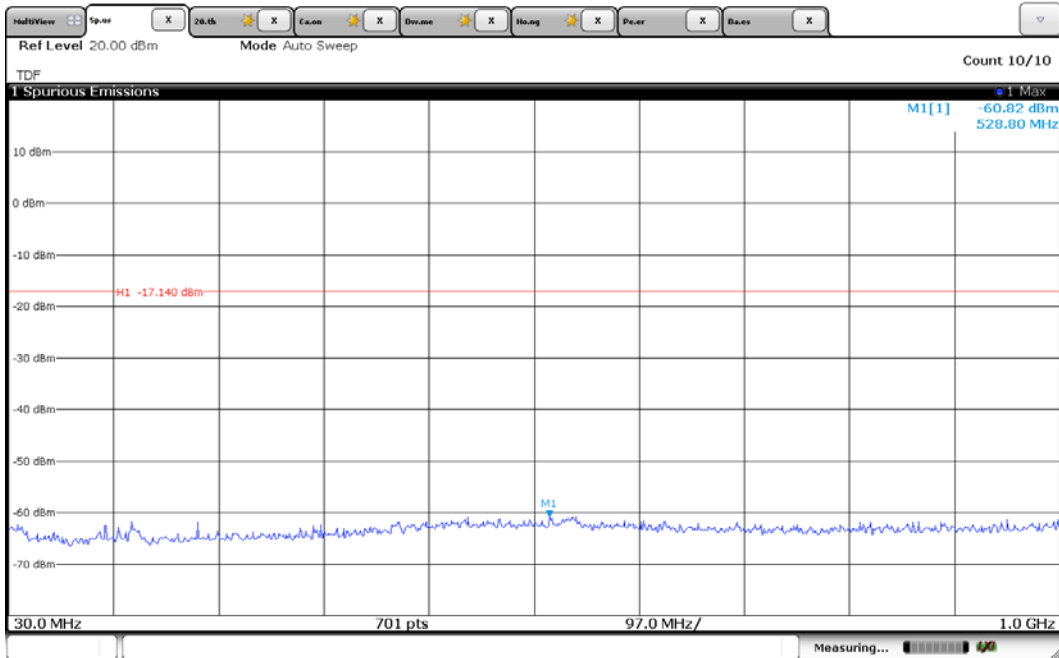

[CH Mid]

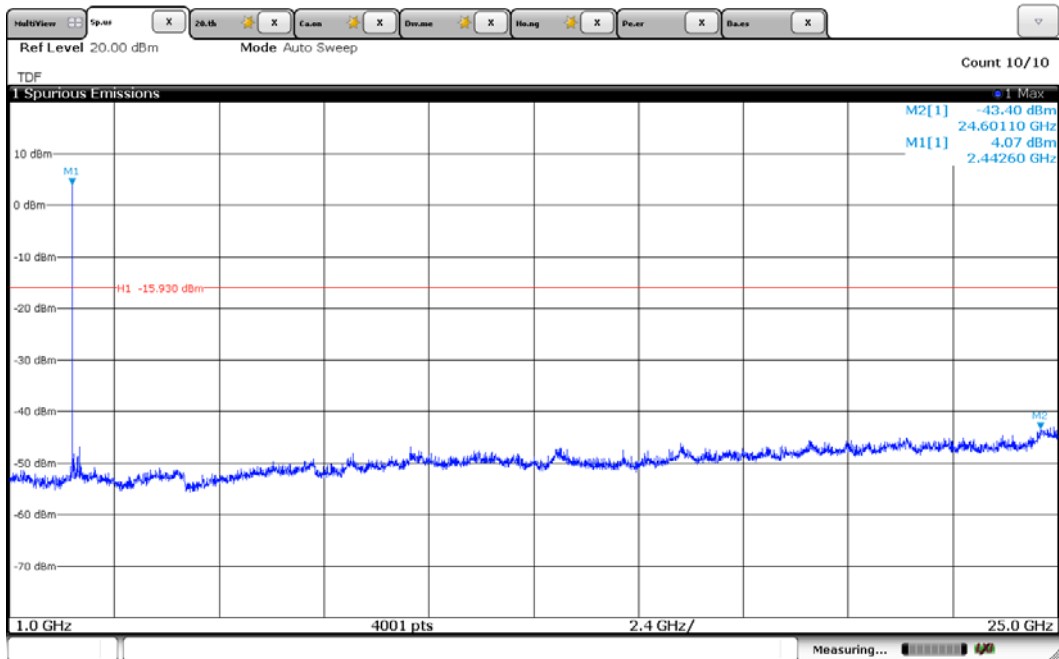
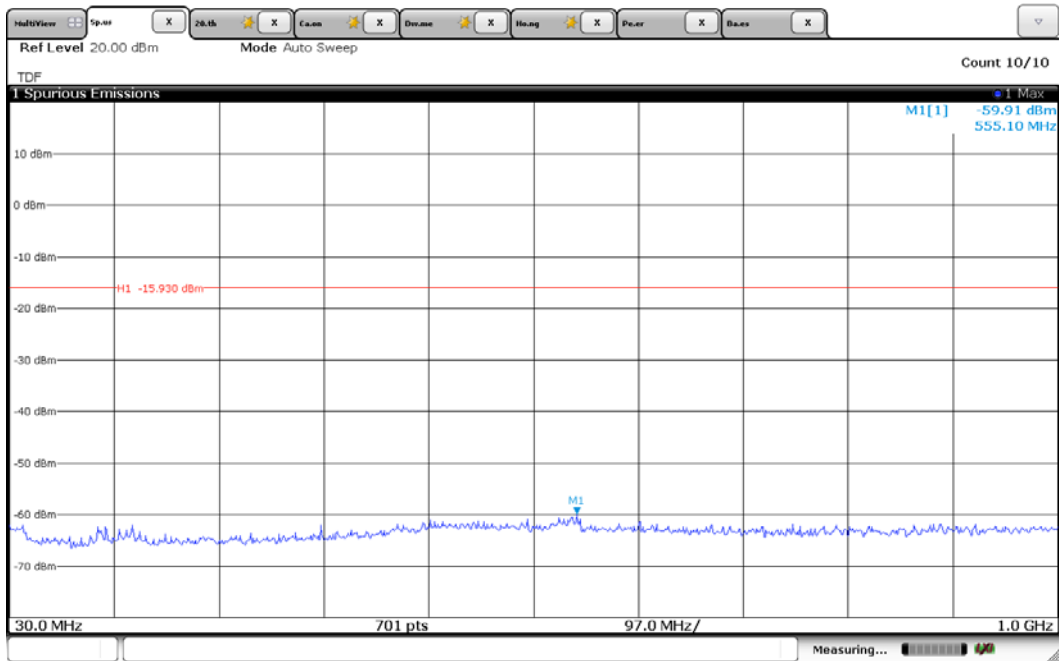

[CH High]

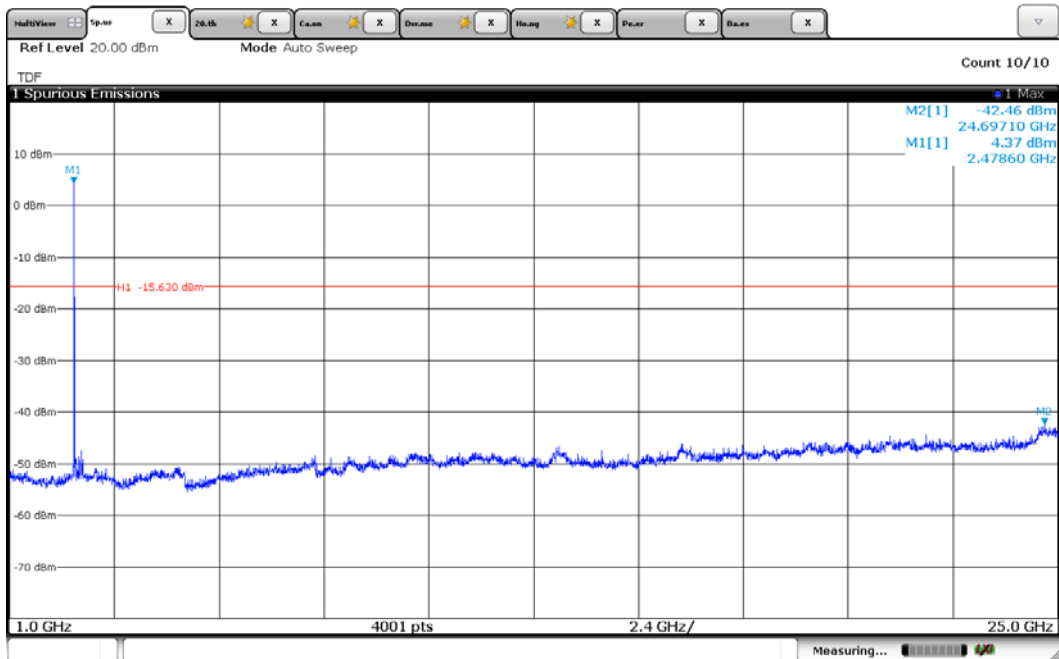
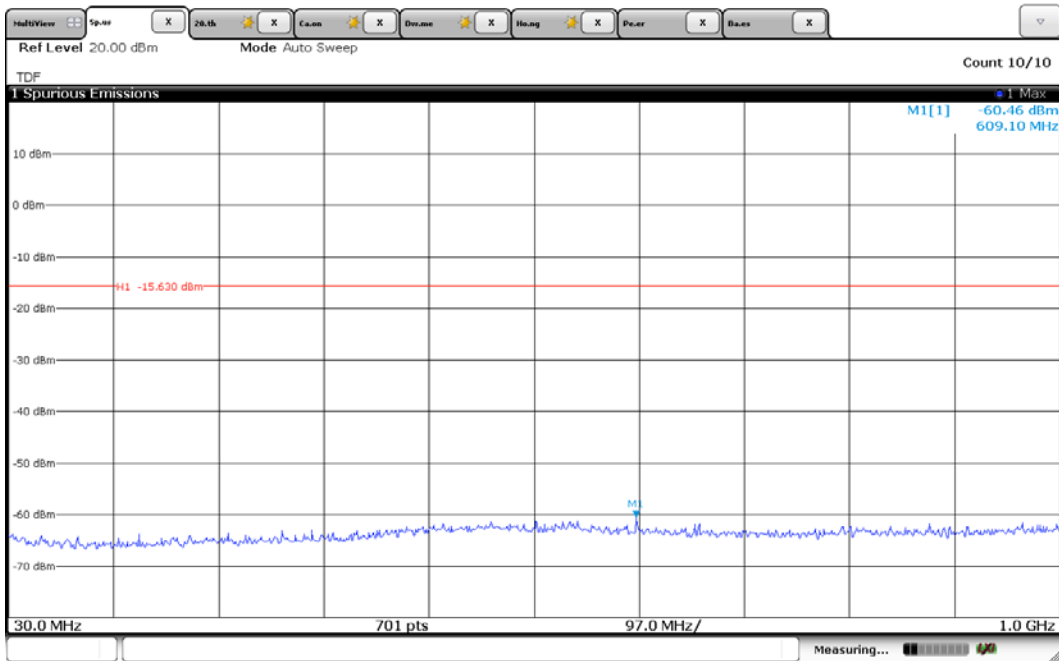

5.8 Conducted Emissions Measurement

EUT	HP Sprocket Photo Printer / SNPRH-1603
Limit apply to	FCC Part 15.207
Test Date	August 03, 2016
Environmental of Test	(23.2 ± 0.0) °C, (51 ± 0) % R.H., (100.8 ± 0.0) kPa
Operating Condition	RF transmitting continuously during the tested.
Result	Passed by 6.54 dB

Limit

For an intentional radiator that is designed to be connected to the public utility (AC) power line, the radio frequency voltage that is conducted back onto the AC power line on any frequency or frequencies within the band 150 kHz to 30 MHz shall not exceed the limits in the following table, as measured using a 50 μH/50 ohms line impedance stabilization network (LISN). Compliance with the provisions of this paragraph shall be based on the measurement of the radio frequency voltage between each power line and ground at the power terminal. The lower limit applies at the boundary between the frequencies ranges.

Frequency of Emission [MHz]	Conducted limit [dB(μV)]	
	Quasi-peak	Average
0.15 - 0.5	66 to 56 *	56 to 46 *
0.5 - 5	56	46
5 - 30	60	50

* Decreases with the logarithm of the frequency.

Test Results

- Refer to see the measured plot in next page.

Conducted Emission Test Data

The following data and graph shows the highest levels of conducted emissions on both polarizations of hot and neutral line.

Detector mode: CISPR Quasi-Peak mode (6 dB Bandwidth: 9 kHz)

NOTES:

1. Please see the measured data and graph in next page.
2. The Level (Result) value was included the reading, LISN factor and cable loss.
3. Delta (Margin) value = Limit - Level (Result)
4. Measurement were performed at the AC Power Inlet in the frequency band of 150 kHz ~ 30 MHz according to the FCC Part 15.207.
5. If the Quasi-Peak limit is met when using a Peak detector receiver, the EUT shall be deemed to meet both limits and measurement with the Quasi-Peak detector receiver is unnecessary.
6. If the average limit is met when using a Quasi-peak detector receiver, the EUT shall be deemed to meet both limits and measurement with the average detector receiver is unnecessary.

Line: HOT

ETL EMC Laboratory
 Conducted Emission Test Result
 EUT: ETLT160721.0083
 Manuf:
 Op Cond:
 Operator:
 Test Spec:
 Comment: HOT

Prescan Measurement:	Detectors:	X PK / + AV
	Meas Time:	see scan settings
	Peaks:	16
	Acc Margin:	10 dB

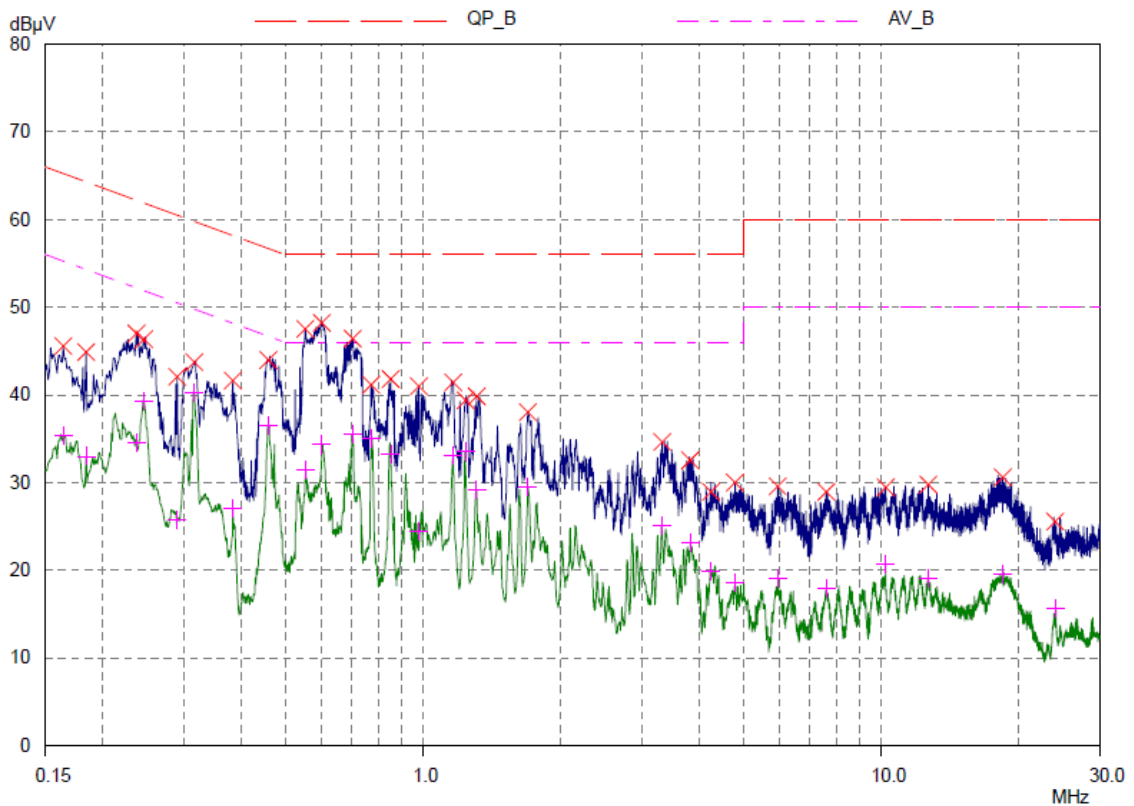

ETL EMC Laboratory

Conducted Emission Test Result

EUT: ETLT160721.0083
 Manuf:
 Op Cond:
 Operator:
 Test Spec:
 Comment: HOT

Prescan Measurement: Detectors: X PK / + AV
 Meas Time: see scan settings
 Peaks: 16
 Acc Margin: 10 dB

Peak Search Results

Frequency MHz	PK Level dBμV	PK Limit dBμV	PK Delta dB
0.164	45.57	65.26	19.69
0.184	44.88	64.30	19.42
0.237	47.01	62.20	15.19
0.246	46.37	61.89	15.52
0.291	42.07	60.50	18.43
0.317	43.73	59.79	16.06
0.385	41.62	58.17	16.55
0.46	43.97	56.69	12.72
0.554	47.52	56.00	8.48
0.602	48.21	56.00	7.79
0.703	46.40	56.00	9.60
0.771	41.15	56.00	14.85
0.851	41.80	56.00	14.20
0.98	40.98	56.00	15.02
1.165	41.42	56.00	14.58
1.24	39.38	56.00	16.62
1.31	39.83	56.00	16.17
1.695	38.01	56.00	17.99
3.33	34.63	56.00	21.37
3.835	32.55	56.00	23.45
4.26	28.93	56.00	27.07
4.805	29.99	56.00	26.01
5.95	29.55	60.00	30.45
7.6	28.93	60.00	31.07
10.24	29.45	60.00	30.55
12.69	29.77	60.00	30.23
18.45	30.60	60.00	29.40
24.01	25.54	60.00	34.46

* limit exceeded

Peak Search Results (continued)

Frequency MHz	AV Level dB μ V	AV Limit dB μ V	AV Delta dB
0.164	35.39	55.26	19.87
0.184	33.00	54.30	21.30
0.237	34.56	52.20	17.64
0.246	39.27	51.89	12.62
0.291	25.79	50.50	24.71
0.317	40.28	49.79	9.51
0.385	27.04	48.17	21.13
0.46	36.52	46.69	10.17
0.554	31.40	46.00	14.60
0.602	34.30	46.00	11.70
0.703	35.51	46.00	10.49
0.771	35.06	46.00	10.94
0.851	33.22	46.00	12.78
0.98	24.50	46.00	21.50
1.165	33.10	46.00	12.90
1.24	33.49	46.00	12.51
1.31	29.20	46.00	16.80
1.695	29.56	46.00	16.44
3.33	25.10	46.00	20.90
3.835	23.14	46.00	22.86
4.26	19.90	46.00	26.10
4.805	18.56	46.00	27.44
5.95	19.05	50.00	30.95
7.6	17.99	50.00	32.01
10.24	20.62	50.00	29.38
12.69	19.13	50.00	30.87
18.45	19.50	50.00	30.50
24.01	15.62	50.00	34.38

* limit exceeded

Line: Neutral

ETL EMC Laboratory
 Conducted Emission Test Result

EUT: ETLT160721.0083
 Manuf:
 Op Cond:
 Operator:
 Test Spec:
 Comment: N

Prescan Measurement: Detectors: X PK / + AV
 Meas Time: see scan settings
 Peaks: 16
 Acc Margin: 10 dB

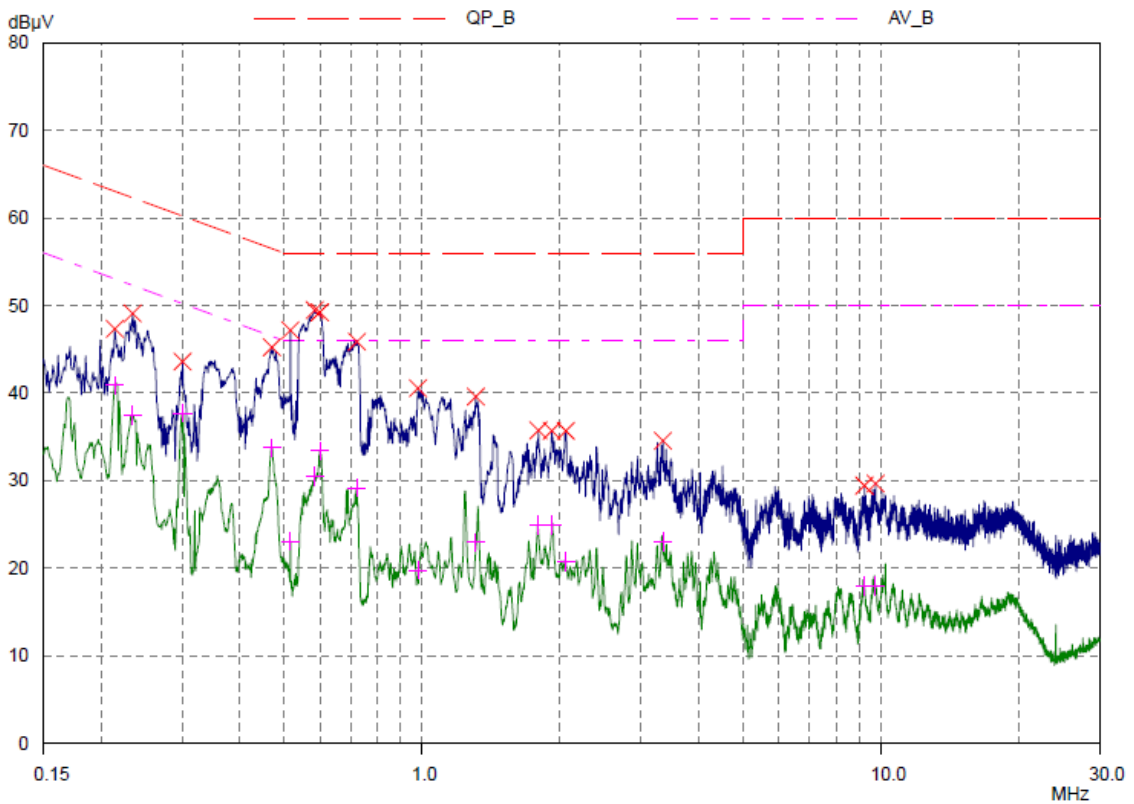

ETL EMC Laboratory

Conducted Emission Test Result

EUT: ETLT160721.0083
 Manuf:
 Op Cond:
 Operator:
 Test Spec:
 Comment: N

Prescan Measurement: Detectors: X PK / + AV
 Meas Time: see scan settings
 Peaks: 16
 Acc Margin: 10 dB

Peak Search Results

Frequency MHz	PK Level dBμV	PK Limit dBμV	PK Delta dB
0.214	47.33	63.05	15.72
0.234	49.07	62.31	13.24
0.301	43.59	60.22	16.63
0.471	45.23	56.50	11.27
0.517	47.17	56.00	8.83
0.584	49.46	56.00	6.54
0.599	49.23	56.00	6.77
0.722	45.88	56.00	10.12
0.981	40.56	56.00	15.44
1.31	39.58	56.00	16.42
1.795	35.74	56.00	20.26
1.92	35.70	56.00	20.30
2.06	35.67	56.00	20.33
3.355	34.55	56.00	21.45
9.22	29.44	60.00	30.56
9.755	29.66	60.00	30.34

Frequency MHz	AV Level dBμV	AV Limit dBμV	AV Delta dB
0.214	40.91	53.05	12.14
0.234	37.46	52.31	14.85
0.301	37.69	50.22	12.53
0.471	33.72	46.50	12.78
0.517	23.06	46.00	22.94
0.584	30.50	46.00	15.50
0.599	33.40	46.00	12.60
0.722	29.16	46.00	16.84
0.981	19.74	46.00	26.26
1.31	22.98	46.00	23.02
1.795	24.96	46.00	21.04
1.92	24.91	46.00	21.09

* limit exceeded

Peak Search Results (continued)

Frequency MHz	PK Level dBµV	PK Limit dBµV	PK Delta dB
14.91	50.09	60.00	9.91
15.5	50.53	60.00	9.47
15.98	48.67	60.00	11.33
16.57	48.34	60.00	11.66
20.0	46.53	60.00	13.47
20.71	46.73	60.00	13.27
21.54	47.41	60.00	12.59
26.76	44.60	60.00	15.40
27.22	46.36	60.00	13.64
27.81	46.53	60.00	13.47

Frequency MHz	AV Level dBµV	AV Limit dBµV	AV Delta dB
0.15	19.45	56.00	36.55
0.159	20.05	55.52	35.47
0.201	38.41	53.57	15.16
0.304	35.86	50.13	14.27
0.404	32.86	47.77	14.91
0.505	34.73	46.00	11.27
0.607	29.08	46.00	16.92
0.707	24.44	46.00	21.56
0.811	23.38	46.00	22.62
1.315	32.62	46.00	13.38
1.415	31.94	46.00	14.06
1.92	36.54	46.00	9.46
2.025	38.98	46.00	7.02
2.125	38.01	46.00	7.99
2.225	34.63	46.00	11.37
2.325	32.84	46.00	13.16
2.425	31.28	46.00	14.72
2.935	31.36	46.00	14.64
3.035	31.78	46.00	14.22
3.135	30.58	46.00	15.42
3.745	28.76	46.00	17.24
3.845	31.21	46.00	14.79
3.945	31.05	46.00	14.95
4.65	30.07	46.00	15.93
4.755	29.87	46.00	16.13
4.855	29.53	46.00	16.47
7.28	42.89	50.00	7.11
7.38	42.26	50.00	7.74
7.485	41.27	50.00	8.73
12.66	31.37	50.00	18.63
13.25	36.43	50.00	13.57
13.85	39.06	50.00	10.94
14.32	42.41	50.00	7.59
14.91	42.34	50.00	7.66
15.5	42.40	50.00	7.60
15.98	40.84	50.00	9.16
16.57	41.07	50.00	8.93
20.0	39.42	50.00	10.58

* limit exceeded

Peak Search Results (continued)

Frequency MHz	AV Level dB μ V	AV Limit dB μ V	AV Delta dB
2.06	20.73	46.00	25.27
3.355	23.02	46.00	22.98
9.22	17.97	50.00	32.03
9.755	17.96	50.00	32.04

* limit exceeded

5.9 Radio Frequency Exposure

Standard Applicable:

According to §1.1307(b)(1), systems operating under the provisions of this section shall be operated in a manner that ensure that the public is not exposed to radio frequency energy level in excess of the Commission's guideline.

This is a Portable device with its physical nature to be used nearby, the distance between radiating structure and human is less than 20 cm.

As per KDB 447498 D01, The 1-g and 10-g SAR test exclusion thresholds for 100 MHz to 6 GHz at test separation distances ≤ 50 mm are determined by:

$$[(\text{max. power of channel, including tune-up tolerance, mW}) / (\text{min. test separation distance, mm})] * \sqrt{f(\text{GHz})} \leq 3.0 \text{ for 1-g SAR and } \leq 7.5 \text{ for 10-g extremity SAR, where}$$

f (GHz) is the RF channel transmit frequency in GHz
 Power and distance are rounded to the nearest mW and mm before calculation
 The result is rounded to one decimal place for comparison

Measurement Result:

This is a portable device and the Max peak output power is **(3.98 mW)** lower than the threshold given and derived as above, where

$$= 3.98 \text{ (mW)} / 5 \text{ (mm)} * \sqrt{2.441 \text{ (GHz)}} = 1.24 < 3.00$$

As the result of calculation result indicates, the RF exposure generating from given transmitter (transmitter employed digital modulation) can be excluded from SAR measurement, and is deemed compliant with RF exposure as per FCC.

Type of Modulation	Frequency [MHz]	Output Power [dBm]	Target power [dBm]	Allowed tolerance [dB]	Max tune up power [dBm]	Max tune up power [mW]	Separation distance [mm]	RF exposure	Limit
BDR	2 402	4.35	2.5	± 2	4.5	2.82	5	0.87	3.00
	2 441	5.57	4.0	± 2	6.0	3.98	5	1.24	3.00
	2 480	5.50	3.5	± 2	5.5	3.55	5	1.12	3.00
EDR	2 402	2.79	1.0	± 2	3.0	2.00	5	0.62	3.00
	2 441	4.42	2.5	± 2	4.5	2.82	5	0.88	3.00
	2 480	4.55	3.0	± 2	5.0	3.16	5	1.00	3.00

6. SAMPLE CALCULATION

Sample Field Strength Calculation

The field strength is calculated by adding the Antenna Factor and Cable Factor.
The basic equation with a sample calculation is as follows:

$$FS = RA + AF + CF$$

Where FS = Field Strength

RA = Receiver Amplitude

AF = Antenna Factor

CF = Cable Attenuation Factor - Preamplifier Factor

$$dB(\mu V) = 20 \log_{10} (\mu V) : \text{Equation}$$

$$dB(\mu V) = dBm + 107$$

Example : @ 3 000.84 MHz

Limit	=	53.97 dB(μV/m)
Reading	=	56.08 dB(μV)
Antenna Factor + (Cable Loss - Amp. Gain)	=	28.65 + (-35.33) = -6.68 dB(μV/m)
Total	=	49.40 dB(μV/m)
Margin	=	53.97 – 49.40 = 4.57 dB
	=	4.57 dB below Limit

7. List of test equipments used for measurements

	Test Equipment	Model	Mfg.	Serial No.	Cal. Date	Cal. Due Date
<input checked="" type="checkbox"/>	EMI Test Receiver	ESCS30	R&S	100087	16.01.12	17.01.12
<input checked="" type="checkbox"/>	EMI Test Receiver	ESCS30	R&S	847793/005	16.03.14	17.03.14
<input checked="" type="checkbox"/>	EMI Test Receiver	ESCI7	R&S	100851	15.09.04	16.09.04
<input checked="" type="checkbox"/>	Two-Line V-Network	ENV216	R&S	101715	16.03.15	17.03.15
<input checked="" type="checkbox"/>	Two-Line V-Network	ENV216	R&S	102055	16.04.11	17.04.11
<input checked="" type="checkbox"/>	Loop Antenna	6502	EMCO	00033743	14.09.23	16.09.23
<input checked="" type="checkbox"/>	LogBicon Antenna	VULB9160	Schwarzbeck	3164	15.06.08	17.06.08
<input checked="" type="checkbox"/>	Horn Antenna	BBHA 9120D	Schwarzbeck	826	16.03.23	18.03.23
<input checked="" type="checkbox"/>	Spectrum Analyzer	FSW43	R&S	103794	15.09.08	16.09.08
<input checked="" type="checkbox"/>	DC Power Supply	SDP 60-5D	SMTECHNO	605DOD 002	16.03.14	17.03.14
<input checked="" type="checkbox"/>	Amplifier	TK-PA18	TESTEK	120020	15.09.03	16.09.03
<input checked="" type="checkbox"/>	Amplifier	310N	SONOMA INSTRUMENT	284750	15.12.08	16.12.08
<input checked="" type="checkbox"/>	Band Reject Filter	WRCGV 2402/2480-2382/2500-52/10SS	Wainwright Instrument	2	15.09.03	16.09.03
<input checked="" type="checkbox"/>	Highpass Filter	WHKX3.0 /18G-6SS	Wainwright Instrument	15	16.03.14	17.03.14
<input checked="" type="checkbox"/>	Attenuator	BW-S10-2W263+	Mini-Circuits	-	16.03.15	17.03.15
<input checked="" type="checkbox"/>	Turn-Table	DS1200-S	Innco Systems Gmbh	2740311	N/A	N/A
<input checked="" type="checkbox"/>	Controller	HD2000	HD GmbH	C/125	N/A	N/A
<input checked="" type="checkbox"/>	Turn-Table	TT 1.35 SI	SES	-	N/A	N/A
<input checked="" type="checkbox"/>	Antenna Master	AM 4.5	SES	-	N/A	N/A