



## FCC TEST REPORT

**FCC ID: 2AJJ2-ACCUPOINT**

On Behalf of

**NOKTA MUHENDISLIK A.S.**

**METAL DETECTOR**

Model No.: AccuPOINT, AccuPOINT Max, AccuPOINT Pro,  
AccuPOINT Ultra, AccuPOINT +, AccuPOINT Plus

Prepared for : NOKTA MUHENDISLIK A.S.  
Address : Melek Aras Blv. No:1, 34953, Aydınlı, KOSB, Tuzla, Istanbul,  
TÜRKİYE

Prepared By : Shenzhen Alpha Product Testing Co., Ltd.  
Address : Building i, No.2, Lixin Road, Fuyong Street, Bao'an District, 518103,  
Shenzhen, Guangdong, China

Report Number : A2310044-C01-R09  
Date of Receipt : October 19, 2023  
Date of Test : October 19, 2023 – October 26, 2023  
Date of Report : October 26, 2023  
Version Number : V0  
**Test Result : Pass**

## TABLE OF CONTENTS

| Description   | Page      |
|---|-----------|
| <b>1. Summary Of Standards And Results .....</b>                  | <b>6</b>  |
| 1.1. Description of Standards and Results .....                   | 6         |
| <b>2. General Information .....</b>                               | <b>7</b>  |
| 2.1. Description of Device (EUT) .....                            | 7         |
| 2.2. Accessories of Device (EUT) .....                            | 8         |
| 2.3. Tested Supporting System Details .....                       | 8         |
| 2.4. Block Diagram of connection between EUT and simulators ..... | 8         |
| 2.5. Test Mode Description .....                                  | 8         |
| 2.6. Test Conditions .....  | 9         |
| 2.7. Test Facility .....  | 9         |
| 2.8. Measurement Uncertainty .....                                | 9         |
| 2.9. Test Equipment List .....                                    | 10        |
| <b>3. Maximum Peak Output Power .....</b>                         | <b>12</b> |
| 3.1. Limit .....  | 12        |
| 3.2. Test Procedure .....   | 12        |
| 3.3. Test Setup .....   | 12        |
| 3.4. Test Result .....  | 12        |
| <b>4. Bandwidth .....</b>   | <b>13</b> |
| 4.1. Limit .....  | 13        |
| 4.2. Test Procedure .....   | 13        |
| 4.3. Test Result .....  | 13        |
| <b>5. Carrier Frequency Separation .....</b>                      | <b>24</b> |
| 5.1. Limit .....  | 24        |
| 5.2. Test Procedure .....   | 24        |
| 5.3. Test Result .....  | 24        |
| <b>6. Number Of Hopping Channel .....</b>                         | <b>26</b> |
| 6.1. Limit .....  | 26        |
| 6.2. Test Procedure .....   | 26        |
| 6.3. Test Result .....  | 26        |
| <b>7. Dwell Time .....</b>  | <b>28</b> |
| 7.1. Test limit .....   | 28        |
| 7.2. Test Procedure .....   | 28        |
| 7.3. Test Result .....  | 28        |
| <b>8. Radiated Emissions .....</b>                                | <b>38</b> |
| 8.1. Limit .....  | 38        |
| 8.2. Block Diagram of Test setup .....                            | 39        |
| 8.3. Test Procedure .....   | 40        |
| 8.4. Test Result .....  | 40        |
| <b>9. Band Edge Compliance .....</b>                              | <b>51</b> |

---

|   |           |
|---|-----------|
| 9.1. Block Diagram of Test Setup .....          | 51        |
| 9.2. Limit .....                                | 51        |
| 9.3. Test Procedure .....                       | 51        |
| 9.4. Test Result.....                           | 51        |
| <b>10. Power Line Conducted Emissions .....</b> | <b>61</b> |
| 10.1. Block Diagram of Test Setup .....         | 61        |
| 10.2. Limit .....                               | 61        |
| 10.3. Test Procedure .....                      | 61        |
| 10.4. Test Result.....                          | 62        |
| <b>11. Antenna Requirements.....</b>            | <b>64</b> |
| 11.1. Limit .....                               | 64        |
| 11.2. Result .....                              | 64        |
| <b>12. Test Setup Photo .....</b>               | <b>65</b> |
| 12.1. Photos of Radiated emission.....          | 65        |
| 12.2. Power Line Conducted Emissions.....       | 66        |
| <b>13. EUT Photo.....</b>                       | <b>67</b> |

### TEST REPORT DECLARATION

Applicant : NOKTA MUHENDISLIK A.S.  
 Address : Melek Aras Blv. No:1, 34953, Aydınlı, KOSB, Tuzla, İstanbul, TÜRKİYE  
 Manufacturer : NOKTA MUHENDISLIK A.S.  
 Address : Melek Aras Blv. No:1, 34953, Aydınlı, KOSB, Tuzla, İstanbul, TÜRKİYE  
 EUT Description : METAL DETECTOR  
 (A) Model No. : AccuPOINT, AccuPOINT Max, AccuPOINT Pro, AccuPOINT Ultra, AccuPOINT +, AccuPOINT Plus  
 (B) Trademark : **NOKTA DETECTION TECHNOLOGIES**

Measurement Standard Used:

**FCC Rules and Regulations Part 15 Subpart C Section 15.247,  
ANSI C63.10-2013**

The device described above is tested by Shenzhen Alpha Product Testing Co., Ltd. to determine the maximum emission levels emanating from the device. The test results are contained in this test report and Shenzhen Alpha Product Testing Co., Ltd. is assumed of full responsibility for the accuracy and completeness of these tests.

After the test, our opinion is that EUT compliance with the requirement of the above standards.

This report applies to above tested sample only. This report shall not be reproduced in parts without written approval of Shenzhen Alpha Product Testing Co., Ltd.

Tested by (name + signature).....: Yannis Wen  
 Project Engineer 

Approved by (name + signature).....: Reak Yang  
 Project Manager 

Date of issue..... : October 26, 2023

### Revision History

| Revision | Issue Date       | Revisions              | Revised By |
|----------|------------------|------------------------|------------|
| V0       | October 26, 2023 | Initial released Issue | Yannis Wen |

## 1. Summary Of Standards And Results

### 1.1. Description of Standards and Results

The EUT have been tested according to the applicable standards as referenced below:

| Test Item                      | Standards Paragraph   | Result |
|--------------------------------|---|--------|
| Maximum Peak Output Power      | FCC Part 15: 15.247(b)(1)   | P      |
| Bandwidth                      | FCC Part 15: 15.215   | P      |
| Carrier Frequency Separation   | FCC Part 15: 15.247(a)(1)   | P      |
| Number Of Hopping Channel      | FCC Part 15: 15.247(a)(1)   | P      |
| Dwell Time                     | FCC Part 15: 15.247(a)(1)   | P      |
| Radiated Emission              | FCC Part 15: 15.209<br>FCC Part 15: 15.247(d)   | P      |
| Band Edge Compliance           | FCC Part 15: 15.247(d)  | P      |
| Power Line Conducted Emissions | FCC Part 15: 15.207   | P      |
| Antenna requirement            | FCC Part 15: 15.203   | P      |
| Note:                          | 1. P is an abbreviation for Pass.<br>2. F is an abbreviation for Fail.<br>3. N/A is an abbreviation for Not Applicable. |        |

## 2. General Information

### 2.1. Description of Device (EUT)

|                     |   |   |
|---------------------|---|---|
| Description/PMN     | : | METAL DETECTOR  |
| Model               | : | AccuPOINT, AccuPOINT Max, AccuPOINT Pro, AccuPOINT Ultra, AccuPOINT                               |
| Number/HVIN(s)      | : | +, AccuPOINT Plus   |
| Diff.               | : | There is no difference except the name of the model. All tests are made with the AccuPOINT model. |
| Test Voltage        | : | DC 3.7V from battery, DC 5V from adapter  |
| Radio Technology    | : | Bluetooth EDR   |
| Operation frequency | : | 2402MHz-2480MHz   |
| Modulation          | : | GFSK, $\pi/4$ -DQPSK, 8DPSK   |
| Channel No.         | : | 79 Channels   |
| Channel Separation  | : | 1MHz  |
| Antenna Type        | : | PCB Antenna, max gain 1.3dBi.<br>Antenna information is provided by applicant.                    |
| Software version    | : | V1.0  |
| Hardware version    | : | V1.0  |

#### Remark:

1. The worst-case simultaneous transmission configuration was evaluated with no non-compliance found. Results in this report are only for Bluetooth EDR function, and there is no other transmitter involved.

## 2.2. Accessories of Device (EUT)

Accessories : /  
 Manufacturer : /  
 Model : /  
 Input : /  
 Output : /

## 2.3. Tested Supporting System Details

| No. | Description | Manufacturer | Model        | Serial Number | Certification or SDOC |
|-----|-------------|--------------|--------------|---------------|-----------------------|
| 1.  | Notebook PC | Lenovo       | ThinkPad E14 | N/A           | SDOC                  |

## 2.4. Block Diagram of connection between EUT and simulators

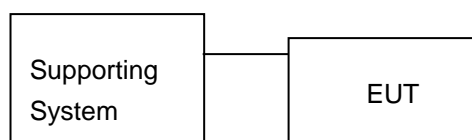

## 2.5. Test Mode Description

The test software “RFTestTool.app” was used to control EUT work in Continuous TX mode, and select test channel, wireless mode

| Tested mode, channel, and data rate information |             |                 |
|---|-------------|-----------------|
| Mode  | Channel     | Frequency (MHz) |
| Carrier Tx Mode                                 | CH0         | 2402            |
|   | CH39        | 2441            |
|   | CH78        | 2480            |
| GFSK / Pi/4-DQPSK hopping on Tx Mode            | CH0 to CH78 | 2402 to 2480    |
| GFSK / Pi/4-DQPSK hopping off Tx Mode           | CH0         | 2402            |
|   | CH39        | 2441            |
|   | CH78        | 2480            |



## 2.6. Test Conditions

| Items              | Required  | Actual |
|--------------------|-----------|--------|
| Temperature range: | 15-35°C   | 25°C   |
| Humidity range:    | 25-75%    | 56%    |
| Pressure range:    | 86-106kPa | 98kPa  |

## 2.7. Test Facility

Shenzhen Alpha Product Testing Co., Ltd

Building i, No.2, Lixin Road, Fuyong Street, Bao'an District, 518103,  
Shenzhen, Guangdong, China

June 21, 2018 File on Federal Communication Commission

Registration Number: 293961

Designation Number: CN1236

July 15, 2019 Certificated by IC

Registration Number: CN0085

## 2.8. Measurement Uncertainty

(95% confidence levels, k=2)

| Item   | Uncertainty               |
|--|---------------------------|
| Uncertainty for Power point Conducted Emissions Test                     | 1.63dB                    |
| Uncertainty for Radiation Emission test in 3m chamber<br>(below 30MHz)   | 3.5dB                     |
| Uncertainty for Radiation Emission test in 3m chamber<br>(30MHz to 1GHz) | 3.74dB(Polarize: V)       |
|  | 3.76dB(Polarize: H)       |
| Uncertainty for Radiation Emission test in 3m chamber<br>(1GHz to 25GHz) | 3.77dB(Polarize: V)       |
|  | 3.80dB(Polarize: H)       |
| Uncertainty for radio frequency  | $5.06 \times 10^{-8}$ GHz |
| Uncertainty for conducted RF Power                                       | 0.40dB                    |
| Uncertainty for temperature  | 0.2°C                     |
| Uncertainty for humidity   | 1%                        |
| Uncertainty for DC and low frequency voltages                            | 0.06%                     |

## 2.9. Test Equipment List

| Equipment                   | Manufacture   | Model No.        | Firmware version | Serial No.                 | Last cal.  | Cal Interval |
|-----------------------------|---------------|------------------|------------------|----------------------------|------------|--------------|
| 9*6*6 anechoic chamber      | CHENYU        | 9*6*6            | /                | N/A                        | 2022.05.17 | 3Year        |
| Spectrum analyzer           | ROHDE&SCHWARZ | FSV40-N          | 2.3              | 102137                     | 2023.08.16 | 1Year        |
| Spectrum analyzer           | Agilent       | N9020A           | A.14.16          | MY499100060                | 2023.08.16 | 1Year        |
| Receiver                    | ROHDE&SCHWARZ | ESR              | 2.28 SP1         | 1316.3003K03-10<br>2082-Wa | 2023.08.16 | 1Year        |
| Receiver                    | R&S           | ESCI             | 4.42 SP1         | 101165                     | 2023.08.16 | 1Year        |
| Bilog Antenna               | Schwarzbeck   | VULB 9168        | /                | VULB 9168#627              | 2023.08.28 | 1Year        |
| Horn Antenna                | SCHWARZBECK   | BBHA 9120<br>D   | /                | 2106                       | 2023.08.19 | 1Year        |
| Loop Antenna                | SCHWARZBECK   | FMZB<br>1519B    | /                | 00128                      | 2023.08.19 | 1Year        |
| RF Cable                    | Resenberger   | Cable 1          | /                | RE1                        | 2023.08.16 | 1Year        |
| RF Cable                    | Resenberger   | Cable 2          | /                | RE2                        | 2023.08.16 | 1Year        |
| RF Cable                    | Resenberger   | Cable 3          | /                | CE1                        | 2023.08.16 | 1Year        |
| Pre-amplifier               | HP            | HP8347A          | /                | 2834A00455                 | 2023.08.16 | 1Year        |
| Pre-amplifier               | Agilent       | 8449B            | /                | 3008A02664                 | 2023.08.16 | 1Year        |
| L.I.S.N.#1                  | Schwarzbeck   | NSLK8126         | /                | 8126-466                   | 2023.08.16 | 1Year        |
| L.I.S.N.#2                  | ROHDE&SCHWARZ | ENV216           | /                | 101043                     | 2023.08.16 | 1Year        |
| Horn Antenna                | SCHWARZBECK   | BBHA 9170        | /                | 00946                      | 2023.08.19 | 1Year        |
| Preamplifier                | SKET          | LNPA_1840<br>-50 | /                | SK2018101801               | 2023.08.16 | 1 Year       |
| Power Meter                 | Agilent       | E9300A           | /                | MY41496628                 | 2023.08.16 | 1 Year       |
| Power Sensor                | DARE          | RPR3006W         | /                | 15100041SNO91              | 2023.08.16 | 1 Year       |
| Temp. & Humid. Chamber      | Teelong       | TL-HW408S        | /                | TL-20191205-01             | 2023.07.25 | 1 Year       |
| Switching Mode Power Supply | JUNKE         | JK12010S         | /                | 20140927-6                 | 2023.08.16 | 1 Year       |
| Adjustable attenuator       | MWRftest      | N/A              | /                | N/A                        | N/A        | N/A          |
| 10dB Attenuator             | Mini-Circuits | DC-6G            | /                | N/A                        | N/A        | N/A          |

| <b>Software Information</b> |               |              |           |
|-----------------------------|---------------|--------------|-----------|
| Test Item                   | Software Name | Manufacturer | Version   |
| RE                          | EZ-EMC        | Farad        | Alpha-3A1 |
| CE                          | EZ-EMC        | Farad        | Alpha-3A1 |
| RF-CE                       | MTS 8310      | MWRFtest     | V2.0.0.0  |

### 3. Maximum Peak Output Power

#### 3.1. Limit

Please refer FCC part 15.247 & RSS-247..

For frequency hopping systems operating in the 2400-2483.5 MHz band employing at least 75 non-overlapping hopping channels, and all frequency hopping systems in the 5725-5850 MHz band: 1 watt. For all other frequency hopping systems in the 2400-2483.5 MHz band: 0.125 watts, the e.i.r.p shall not exceed 4W

#### 3.2. Test Procedure

The transmitter output is connected to the RF Power meter. The Power meter is set to the peak power detection.

#### 3.3. Test Setup

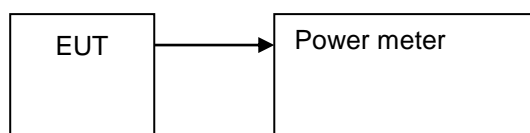

#### 3.4. Test Result

| Condition | Mode  | Frequency (MHz) | Antenna | Conducted Power (dBm) | Duty Factor (dB) | E.I.R.P. (dBm) | Limit (dBm) | Verdict |
|-----------|-------|-----------------|---------|-----------------------|------------------|----------------|-------------|---------|
| NVNT      | 1-DH1 | 2402            | Ant1    | 0.876                 | 0                | 2.876          | 21          | Pass    |
| NVNT      | 1-DH1 | 2441            | Ant1    | 0.818                 | 0                | 2.818          | 21          | Pass    |
| NVNT      | 1-DH1 | 2480            | Ant1    | 0.53                  | 0                | 2.53           | 21          | Pass    |
| NVNT      | 1-DH3 | 2441            | Ant1    | 1.315                 | 0                | 3.315          | 21          | Pass    |
| NVNT      | 1-DH5 | 2441            | Ant1    | 1.334                 | 0                | 3.334          | 21          | Pass    |
| NVNT      | 2-DH1 | 2402            | Ant1    | 1.205                 | 0                | 3.205          | 21          | Pass    |
| NVNT      | 2-DH1 | 2441            | Ant1    | 1.519                 | 0                | 3.519          | 21          | Pass    |
| NVNT      | 2-DH1 | 2480            | Ant1    | 1.45                  | 0                | 3.45           | 21          | Pass    |
| NVNT      | 2-DH3 | 2441            | Ant1    | 2.182                 | 0                | 4.182          | 21          | Pass    |
| NVNT      | 2-DH5 | 2441            | Ant1    | 1.981                 | 0                | 3.981          | 21          | Pass    |
| NVNT      | 3-DH1 | 2402            | Ant1    | 2.519                 | 0                | <b>4.519</b>   | 21          | Pass    |
| NVNT      | 3-DH1 | 2441            | Ant1    | 2.319                 | 0                | 4.319          | 21          | Pass    |
| NVNT      | 3-DH1 | 2480            | Ant1    | 1.565                 | 0                | 3.565          | 21          | Pass    |
| NVNT      | 3-DH3 | 2441            | Ant1    | 2.356                 | 0                | 4.356          | 21          | Pass    |
| NVNT      | 3-DH5 | 2441            | Ant1    | 2.2                   | 0                | 4.2            | 21          | Pass    |

## 4. Bandwidth

### 4.1. Limit

Intentional radiators operating under the alternative provisions to the general emission limits, as contained in RSS-GEN, FCC Section 15.247(a)(1), must be designed to ensure that the 20 dB bandwidth of the emission, or whatever bandwidth may otherwise be specified in the specific rule section under which the equipment operates, is contained within the frequency band designated in the rule section under which the equipment is operated.

### 4.2. Test Procedure

The RF output of EUT was connected to the spectrum analyzer by RF cable and attenuator. The bandwidth of the fundamental frequency was measured by spectrum analyzer with 30kHz RBW and 100kHz VBW. The 20dB bandwidth is defined as the total spectrum the power of which is higher than peak power minus 20dB.

### 4.3. Test Result

| Condition | Mode  | Frequency (MHz) | Antenna | 99% OBW (MHz) |
|-----------|-------|-----------------|---------|---------------|
| NVNT      | 1-DH1 | 2402            | Ant1    | 0.831         |
| NVNT      | 1-DH1 | 2441            | Ant1    | 0.815         |
| NVNT      | 1-DH1 | 2480            | Ant1    | 0.809         |
| NVNT      | 2-DH1 | 2402            | Ant1    | 1.163         |
| NVNT      | 2-DH1 | 2441            | Ant1    | 1.145         |
| NVNT      | 2-DH1 | 2480            | Ant1    | 1.163         |
| NVNT      | 3-DH1 | 2402            | Ant1    | 1.149         |
| NVNT      | 3-DH1 | 2441            | Ant1    | 1.155         |
| NVNT      | 3-DH1 | 2480            | Ant1    | 1.165         |

OBW NVNT 1-DH1 2402MHz Ant1

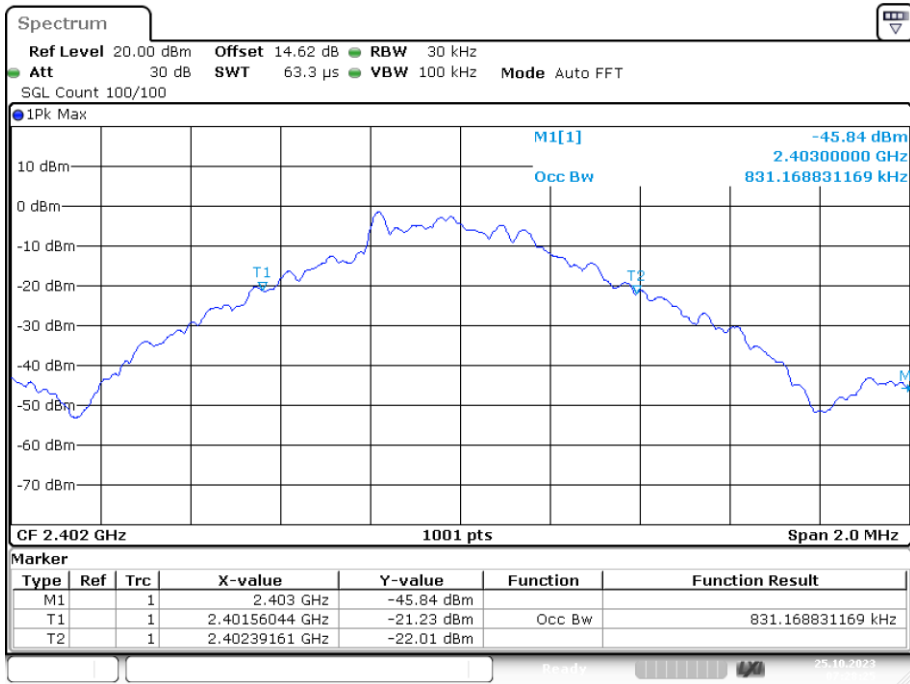

OBW NVNT 1-DH1 2441MHz Ant1

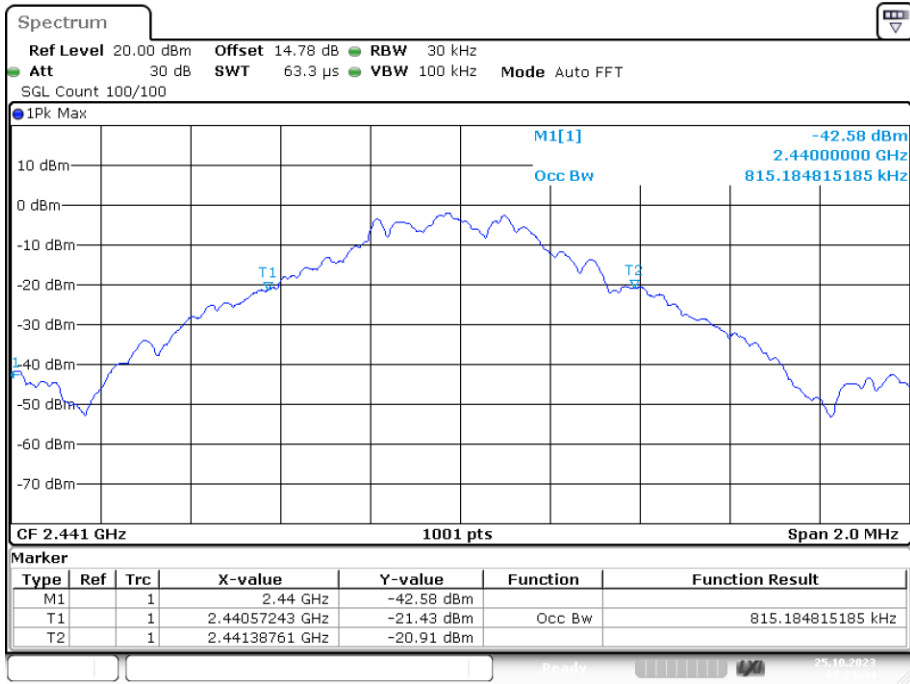

OBW NVNT 1-DH1 2480MHz Ant1

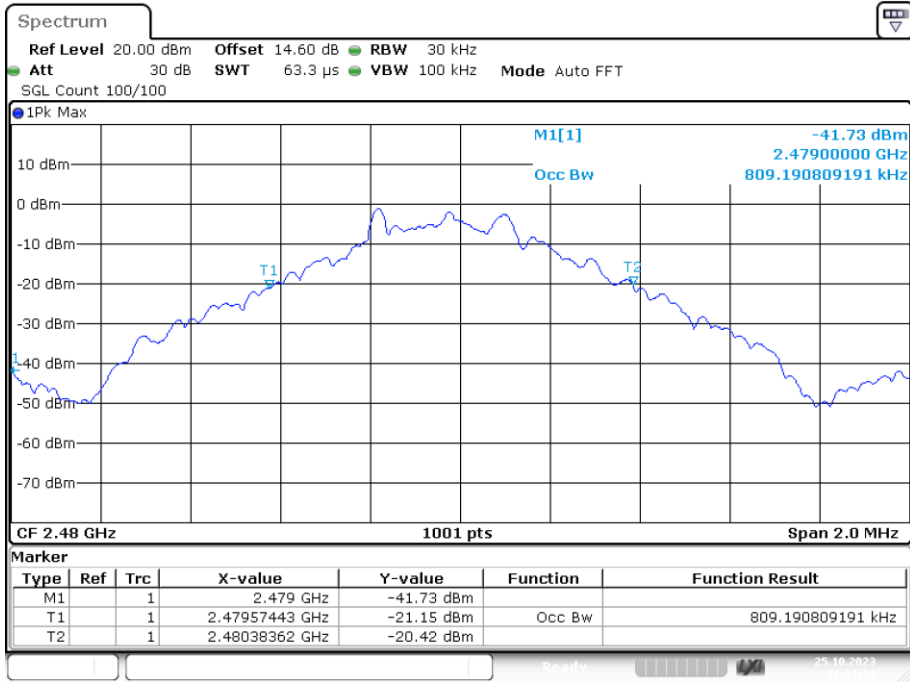

Date: 25.OCT.2023 07:31:09

OBW NVNT 2-DH1 2402MHz Ant1

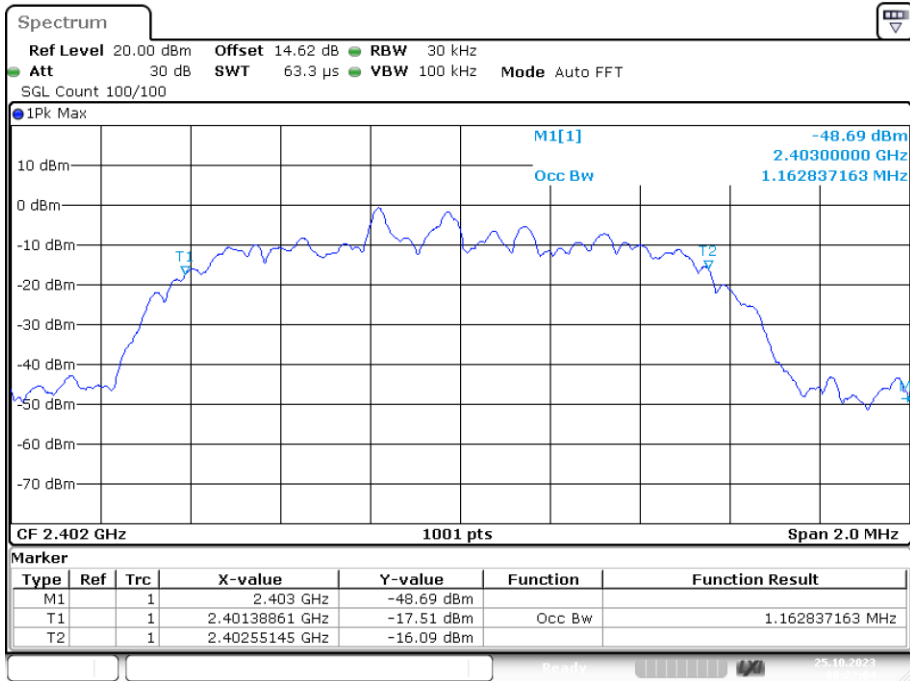

Date: 25.OCT.2023 09:22:04

OBW NVNT 2-DH1 2441MHz Ant1

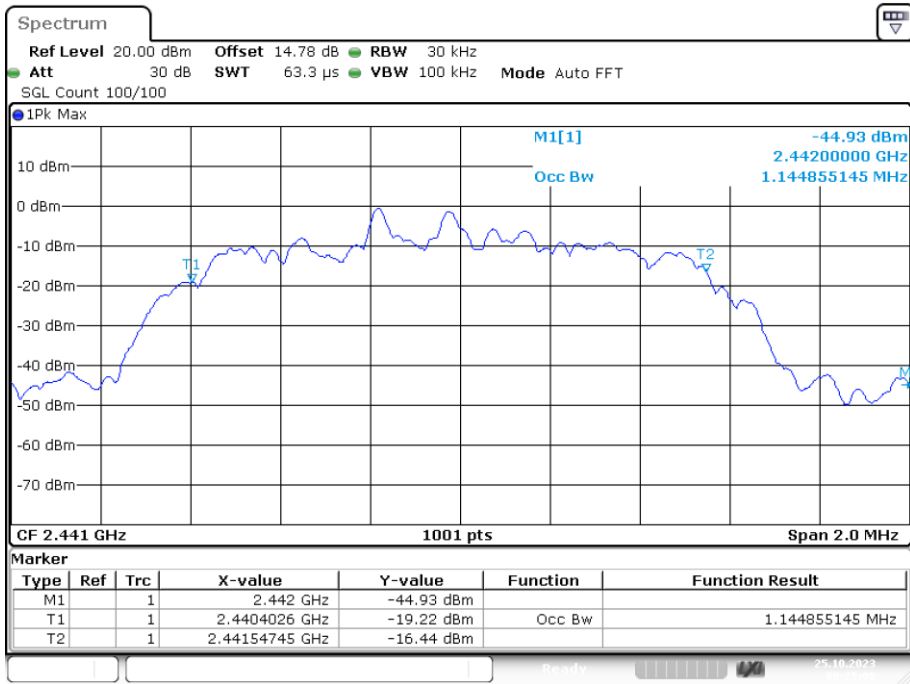

Date: 25.OCT.2023 09:25:08

OBW NVNT 2-DH1 2480MHz Ant1

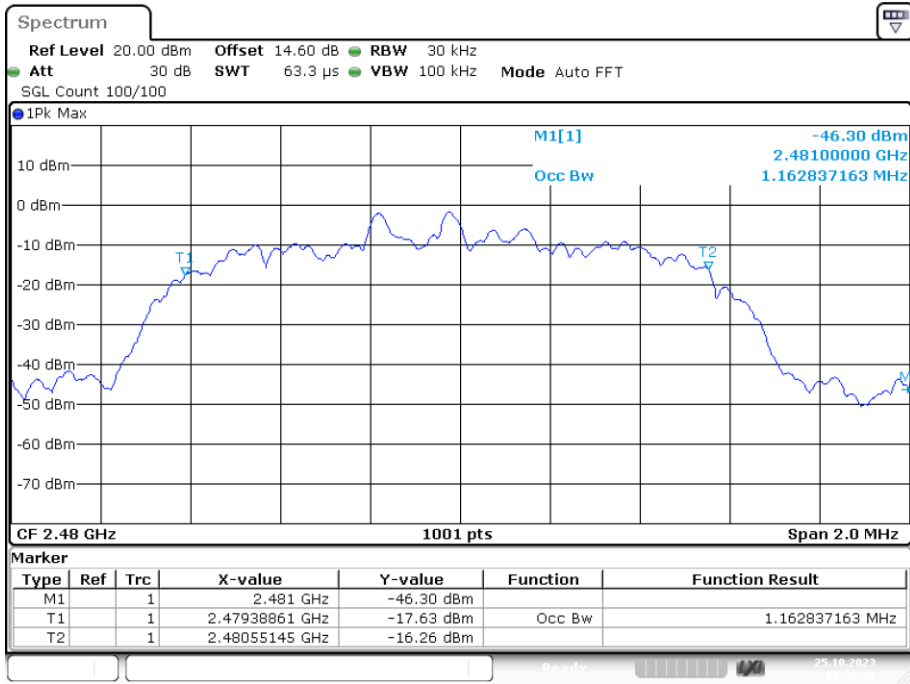

Date: 25.OCT.2023 09:28:42



OBW NVNT 3-DH1 2402MHz Ant1

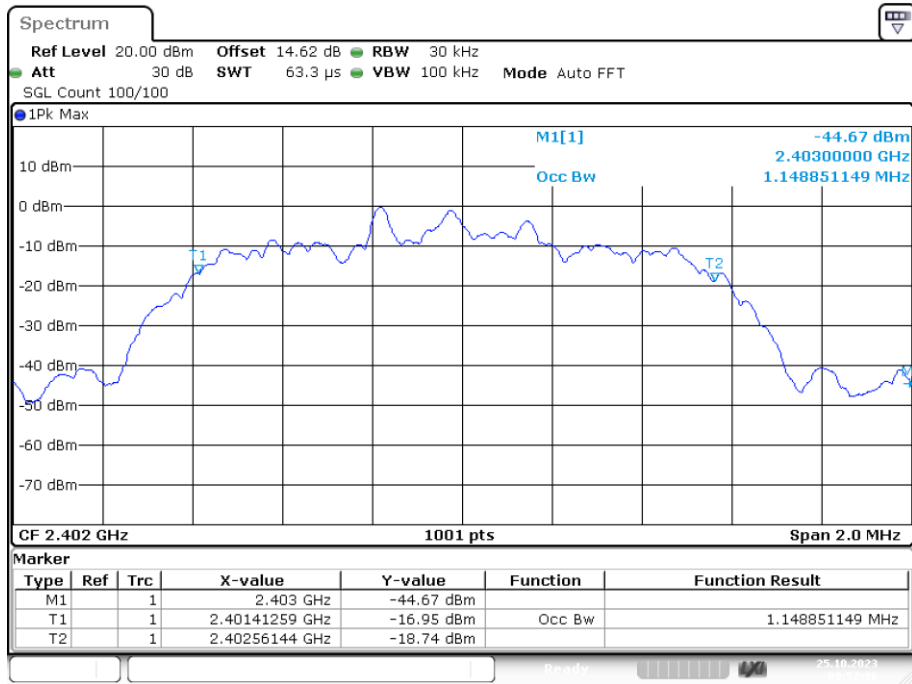

Date: 25.OCT.2023 09:52:36

OBW NVNT 3-DH1 2441MHz Ant1

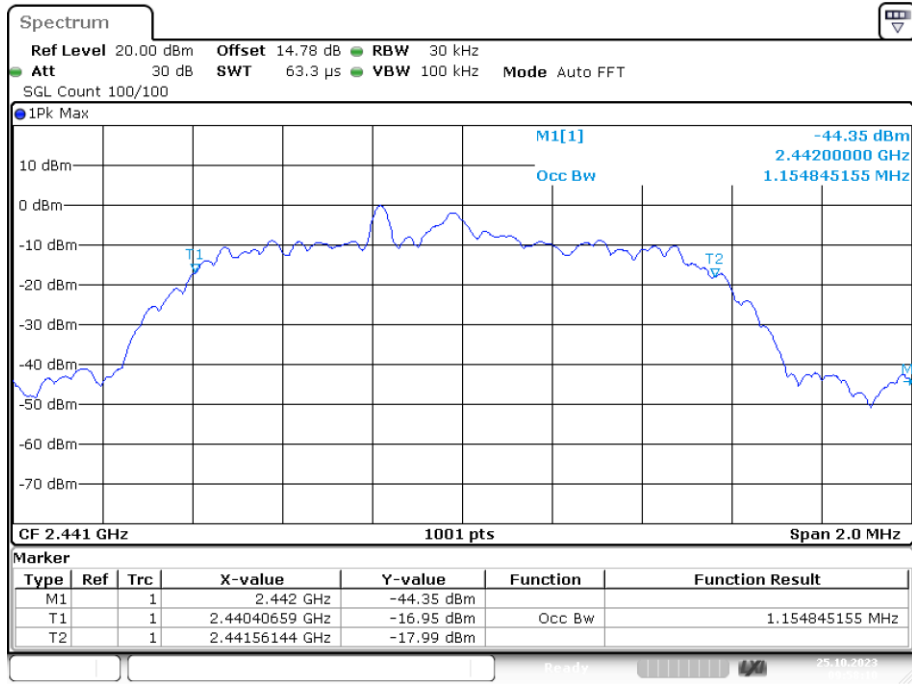

Date: 25.OCT.2023 09:58:09

OBW NVNT 3-DH1 2480MHz Ant1

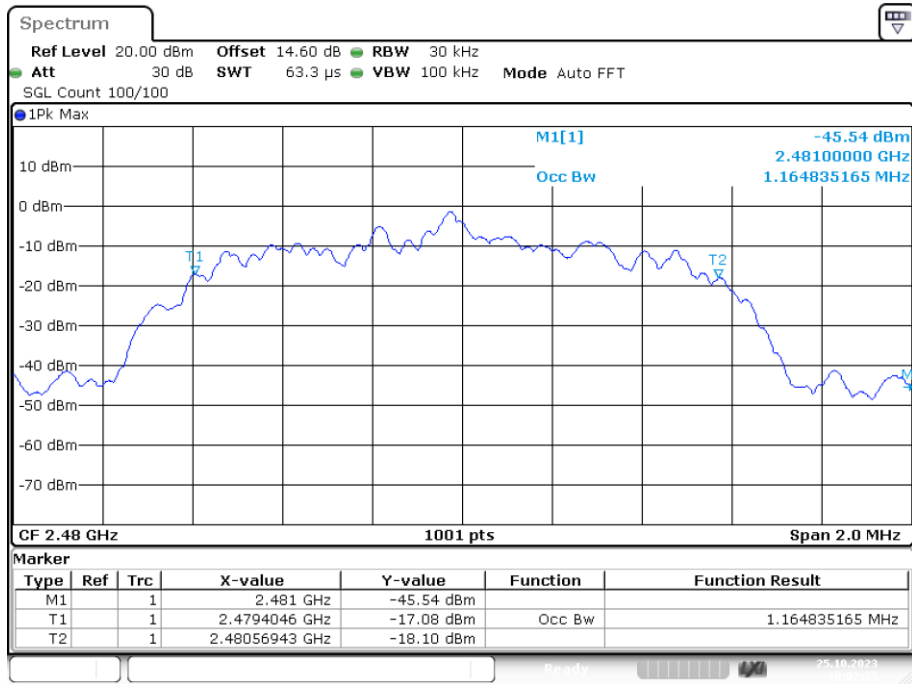

Date: 25.OCT.2023 10:02:35

| Condition | Mode  | Frequency (MHz) | Antenna | -20 dB Bandwidth (MHz) | Limit -20 dB Bandwidth (MHz) | Verdict |
|-----------|-------|-----------------|---------|------------------------|------------------------------|---------|
| NVNT      | 1-DH1 | 2402            | Ant1    | 0.854                  | 0                            | Pass    |
| NVNT      | 1-DH1 | 2441            | Ant1    | 0.88                   | 0                            | Pass    |
| NVNT      | 1-DH1 | 2480            | Ant1    | 0.88                   | 0                            | Pass    |
| NVNT      | 2-DH1 | 2402            | Ant1    | 1.22                   | 0                            | Pass    |
| NVNT      | 2-DH1 | 2441            | Ant1    | 1.25                   | 0                            | Pass    |
| NVNT      | 2-DH1 | 2480            | Ant1    | 1.256                  | 0                            | Pass    |
| NVNT      | 3-DH1 | 2402            | Ant1    | 1.204                  | 0                            | Pass    |
| NVNT      | 3-DH1 | 2441            | Ant1    | 1.208                  | 0                            | Pass    |
| NVNT      | 3-DH1 | 2480            | Ant1    | 1.21                   | 0                            | Pass    |

-20dB Bandwidth NVNT 1-DH1 2402MHz Ant1

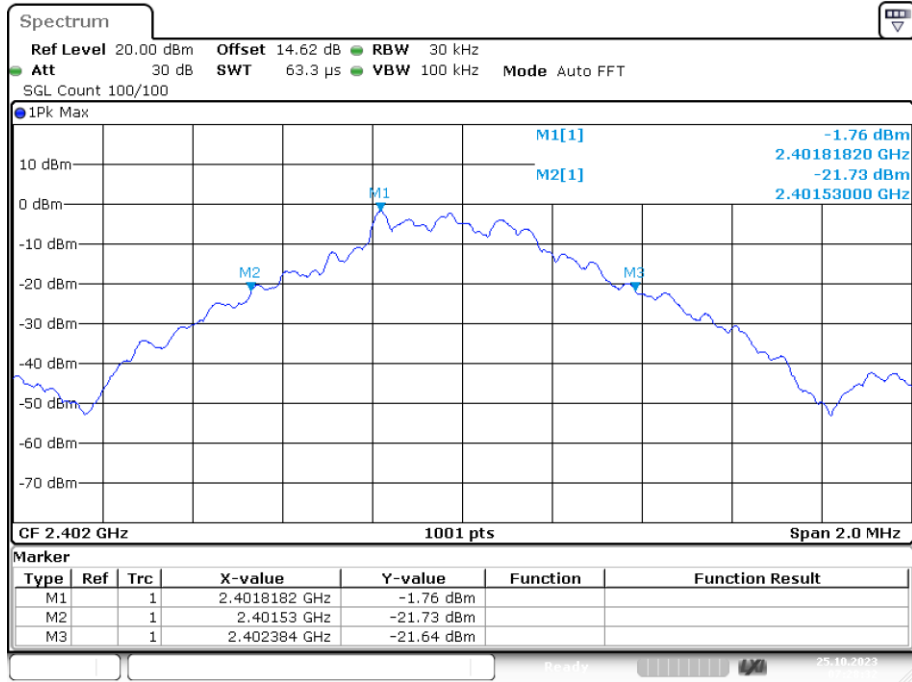

Date: 25.OCT.2023 07:28:33

-20dB Bandwidth NVNT 1-DH1 2441MHz Ant1

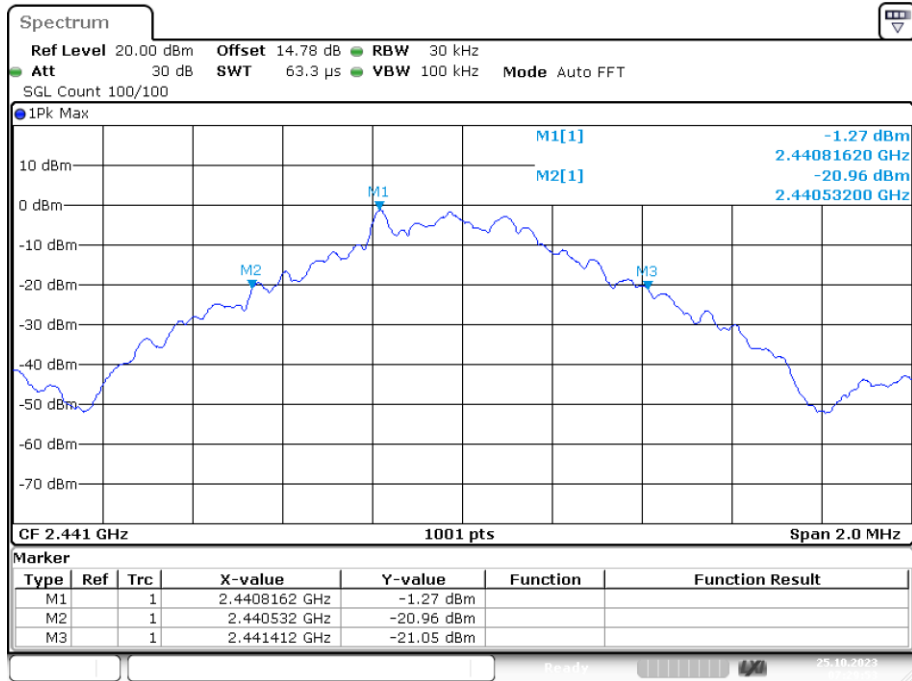

Date: 25.OCT.2023 07:29:52

-20dB Bandwidth NVNT 1-DH1 2480MHz Ant1

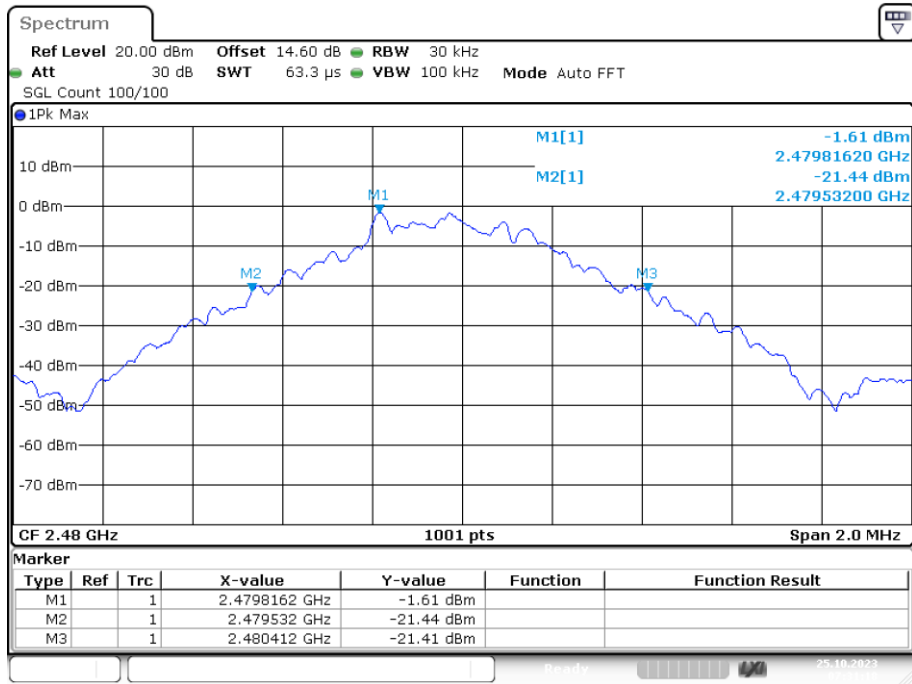

Date: 25.OCT.2023 07:31:18

-20dB Bandwidth NVNT 2-DH1 2402MHz Ant1

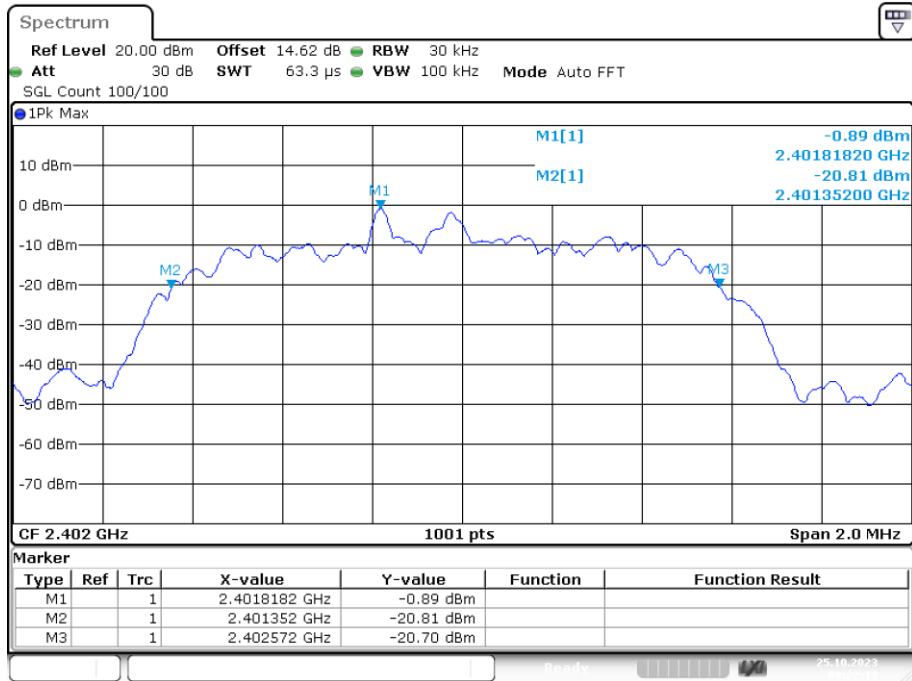

Date: 25.OCT.2023 09:22:13

-20dB Bandwidth NVNT 2-DH1 2441MHz Ant1

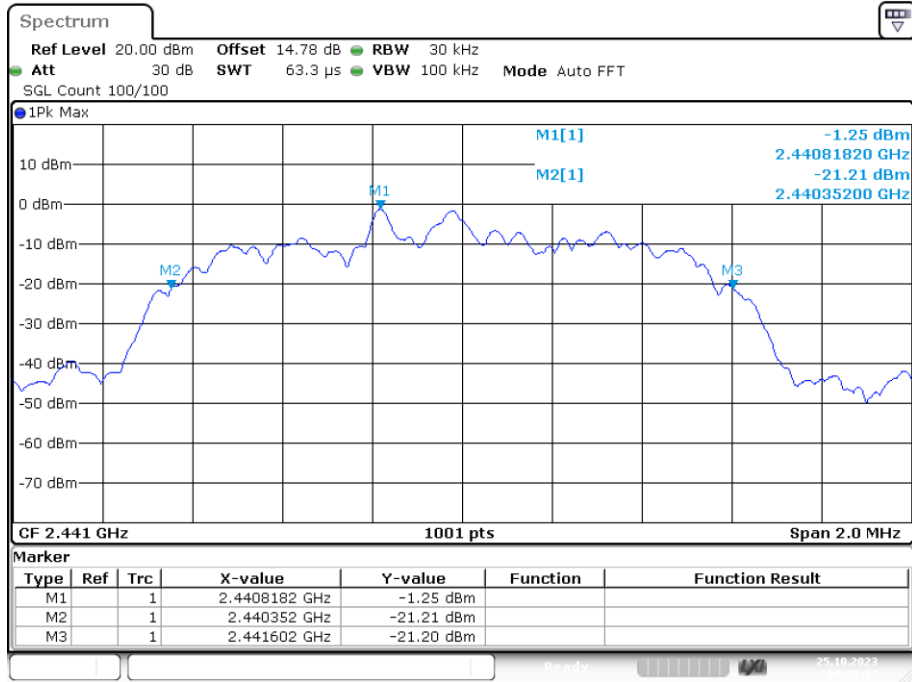

Date: 25.OCT.2023 09:25:16

-20dB Bandwidth NVNT 2-DH1 2480MHz Ant1

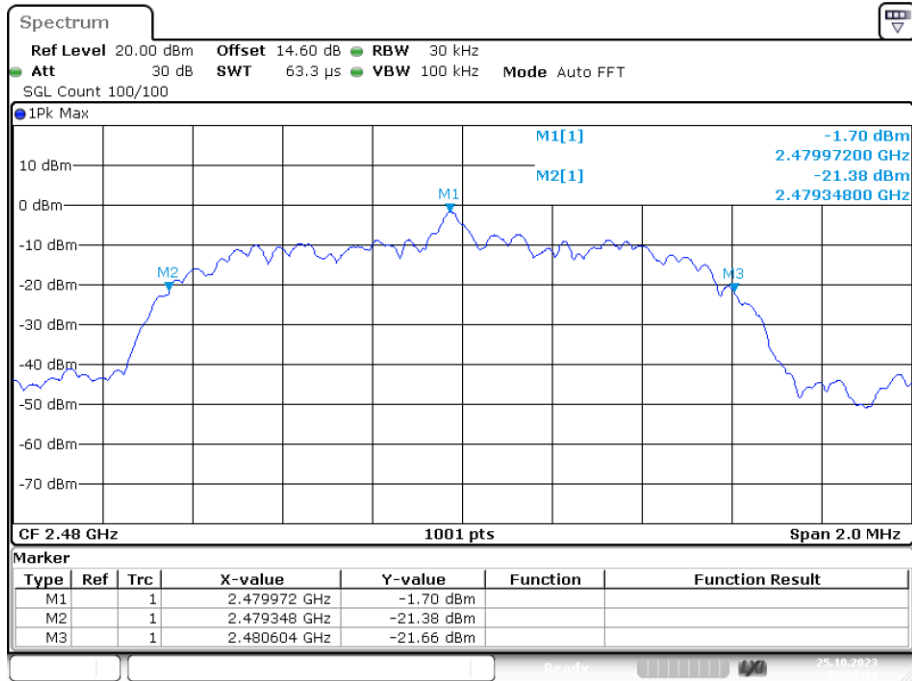

Date: 25.OCT.2023 09:28:51

-20dB Bandwidth NVNT 3-DH1 2402MHz Ant1

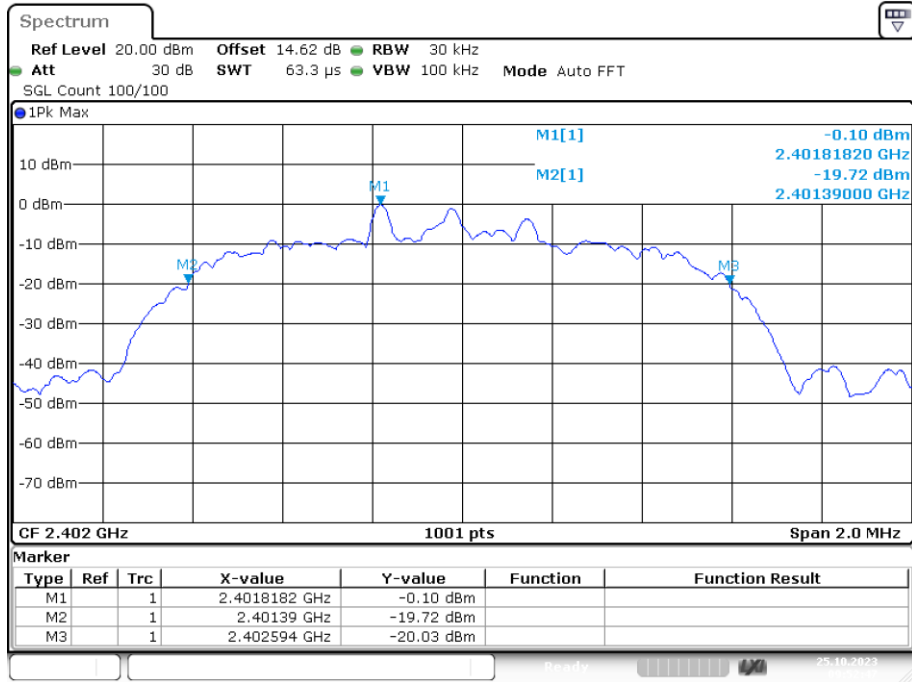

Date: 25.OCT.2023 09:52:46

-20dB Bandwidth NVNT 3-DH1 2441MHz Ant1

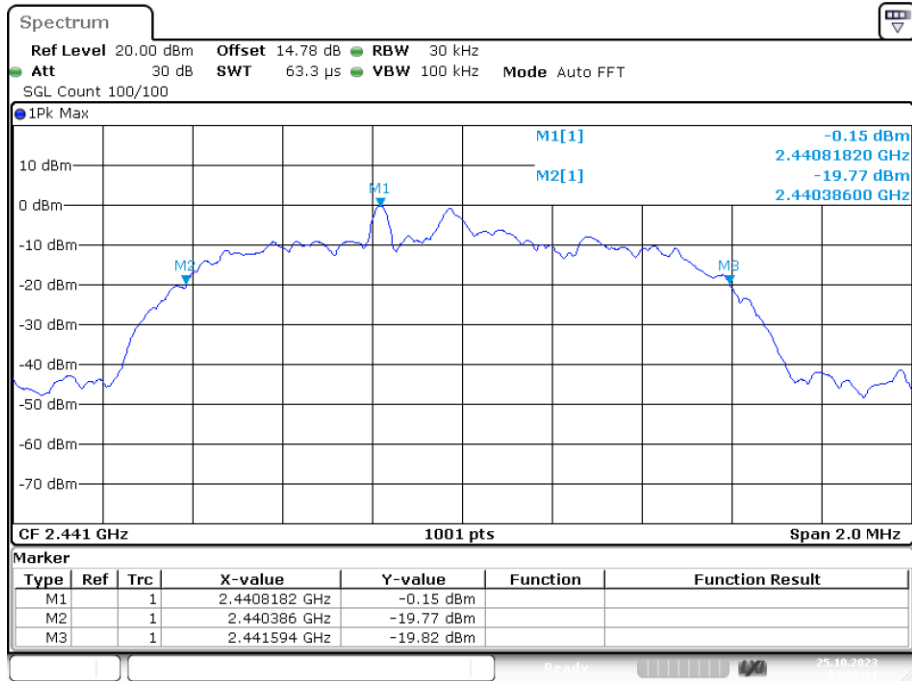

Date: 25.OCT.2023 09:58:21

-20dB Bandwidth NVNT 3-DH1 2480MHz Ant1

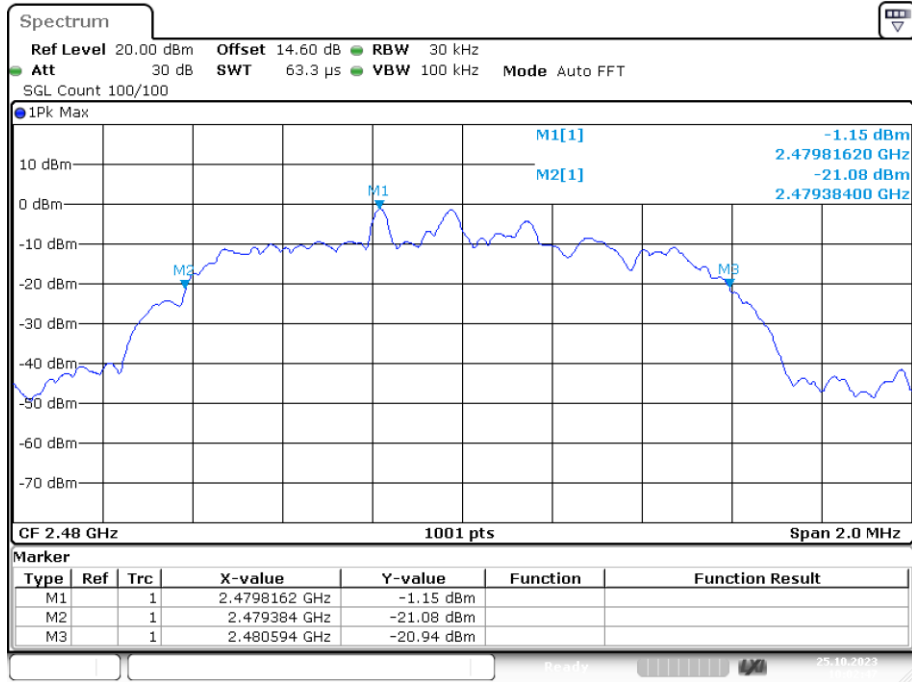

Date: 25.OCT.2023 10:02:47

## 5. Carrier Frequency Separation

### 5.1. Limit

Frequency hopping systems shall have hopping channel carrier frequencies separated by a minimum of 25 kHz or the 20 dB bandwidth of the hopping channel, whichever is greater. Alternatively, frequency hopping systems operating in the 2400-2483.5 MHz band may have hopping channel carrier frequencies that are separated by 25 kHz or two-thirds of the 20 dB bandwidth of the hopping channel, whichever is greater, provided the systems operate with an output power no greater than 125 mW

### 5.2. Test Procedure

The RF output of EUT was connected to the spectrum analyzer by RF cable and attenuator. The carrier frequency was measured by spectrum analyzer with 30kHz RBW and 100kHz VBW.

### 5.3. Test Result

| Condition | Mode  | Antenna | Hopping Freq1 (MHz) | Hopping Freq2 (MHz) | HFS (MHz) | Limit (MHz) | Verdict |
|-----------|-------|---------|---------------------|---------------------|-----------|-------------|---------|
| NVNT      | 1-DH1 | Ant1    | 2440.816            | 2441.816            | 1         | 0.88        | Pass    |
| NVNT      | 2-DH1 | Ant1    | 2440.816            | 2441.818            | 1.002     | 0.833       | Pass    |
| NVNT      | 3-DH1 | Ant1    | 2440.818            | 2441.818            | 1         | 0.805       | Pass    |

CFS NVNT 1-DH1 2441MHz Ant1

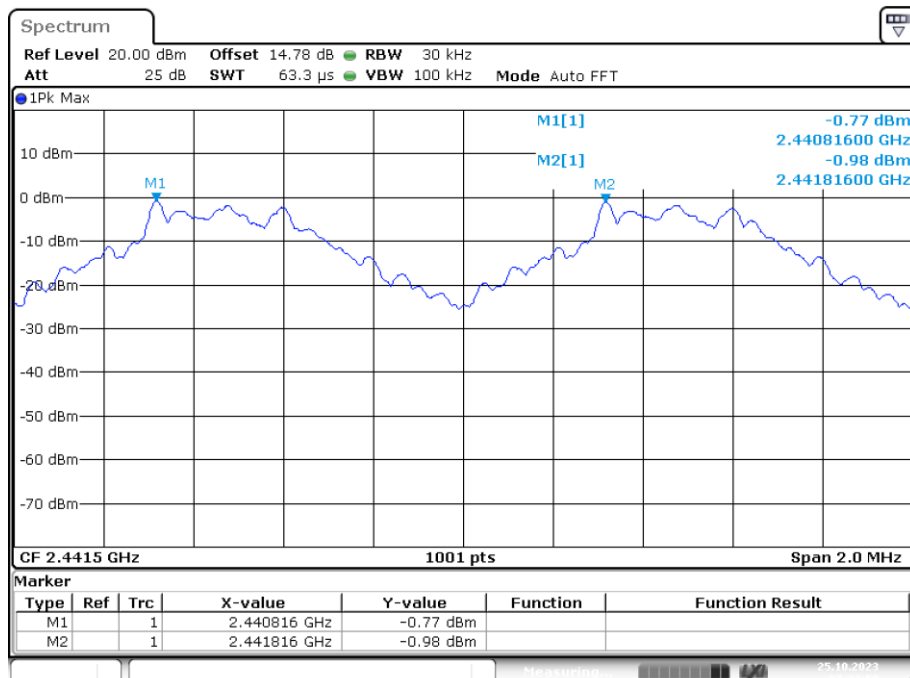

Date: 25.OCT.2023 07:33:58



CFS NVNT 2-DH1 2441MHz Ant1

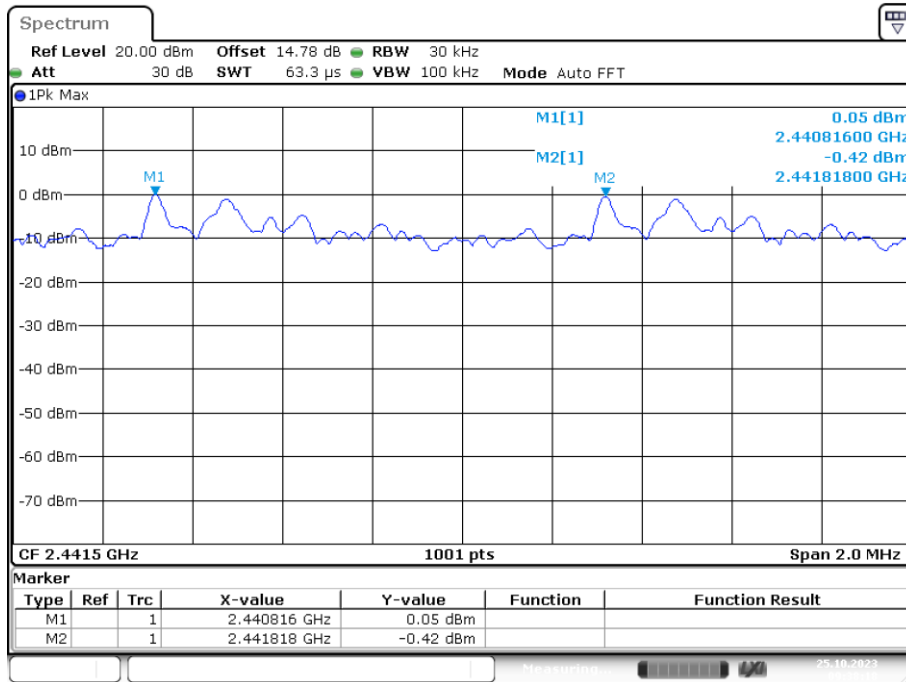

Date: 25.OCT.2023 09:38:18

CFS NVNT 3-DH1 2441MHz Ant1

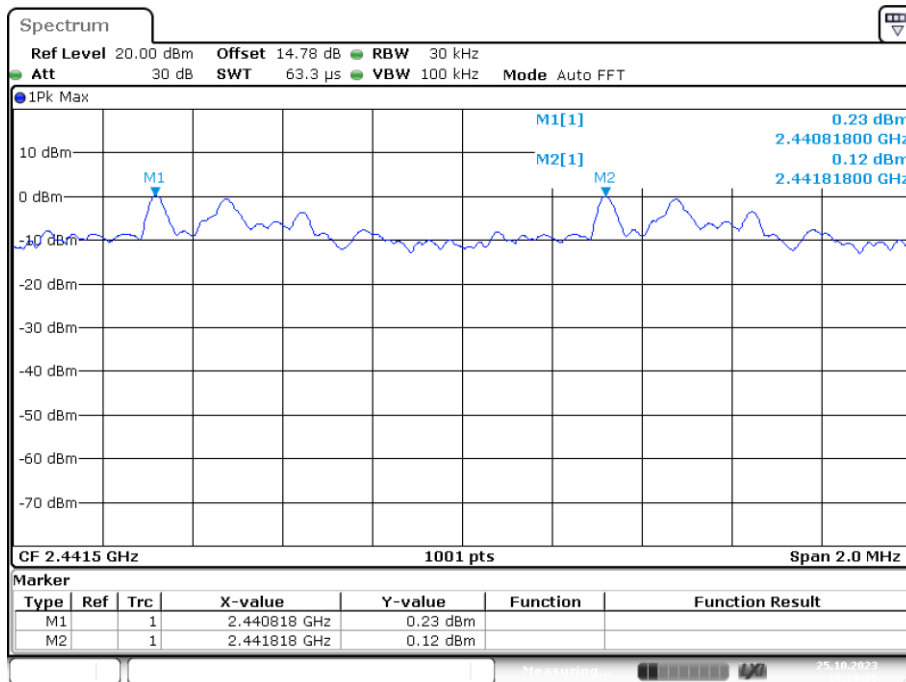

Date: 25.OCT.2023 10:10:26

## 6. Number Of Hopping Channel

### 6.1. Limit

Frequency hopping systems in the 2400-2483.5 MHz band shall use at least 15 channels

### 6.2. Test Procedure

The RF output of EUT was connected to the spectrum analyzer by RF cable and attenuator. The number of hopping channel was measured by spectrum analyzer with 100kHz RBW and 300KHz VBW.

### 6.3. Test Result

| Condition | Mode  | Antenna | Hopping Number | Limit | Verdict |
|-----------|-------|---------|----------------|-------|---------|
| NVNT      | 1-DH1 | Ant1    | 79             | 15    | Pass    |
| NVNT      | 2-DH1 | Ant1    | 79             | 15    | Pass    |
| NVNT      | 3-DH1 | Ant1    | 79             | 15    | Pass    |

Hopping No. NVNT 1-DH1 2441MHz Ant1

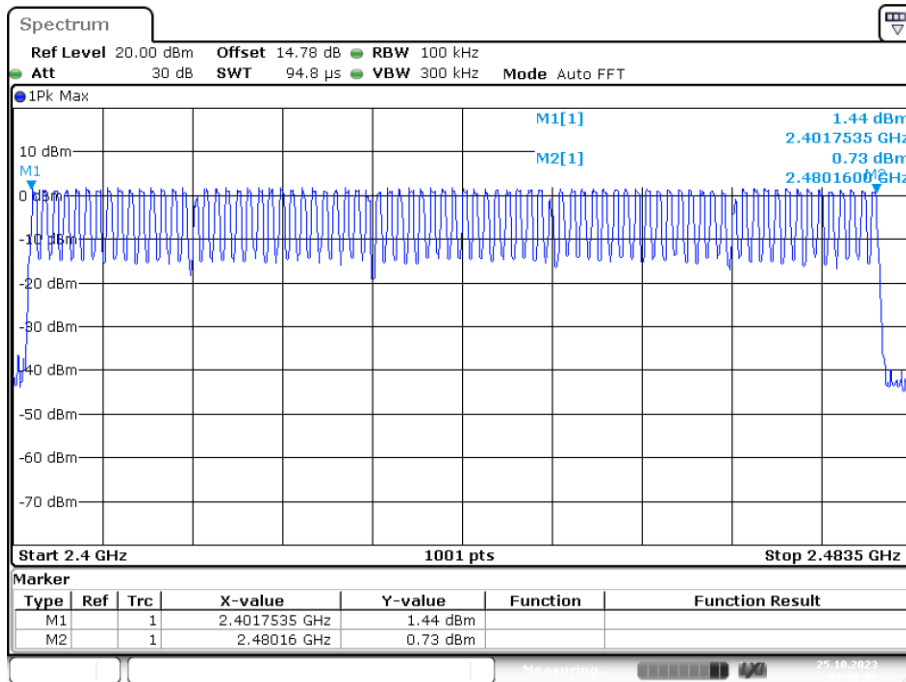

### Hopping No. NVNT 2-DH1 2441MHz Ant1

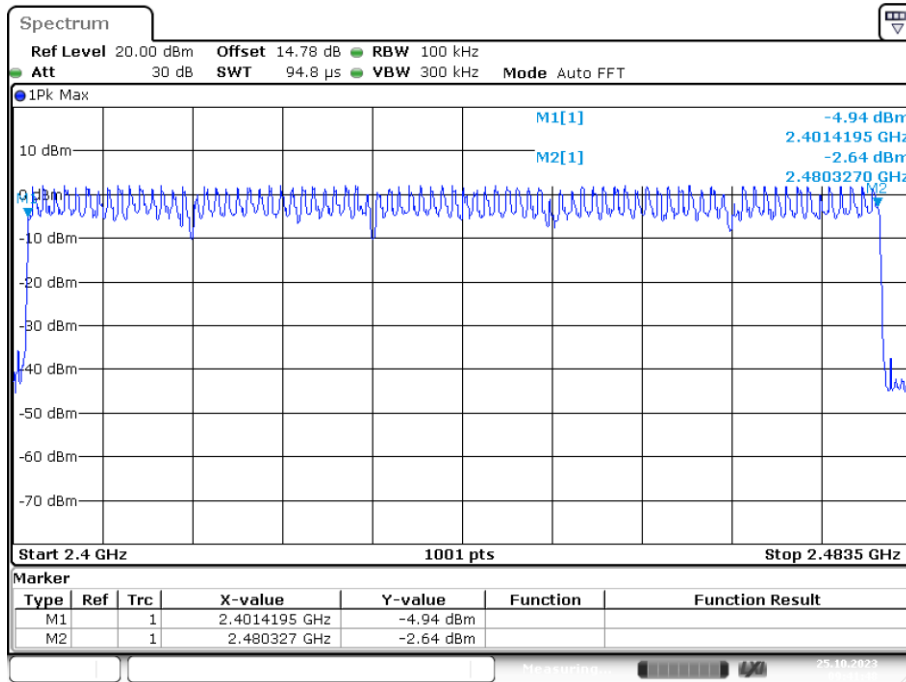

### Hopping No. NVNT 3-DH1 2441MHz Ant1

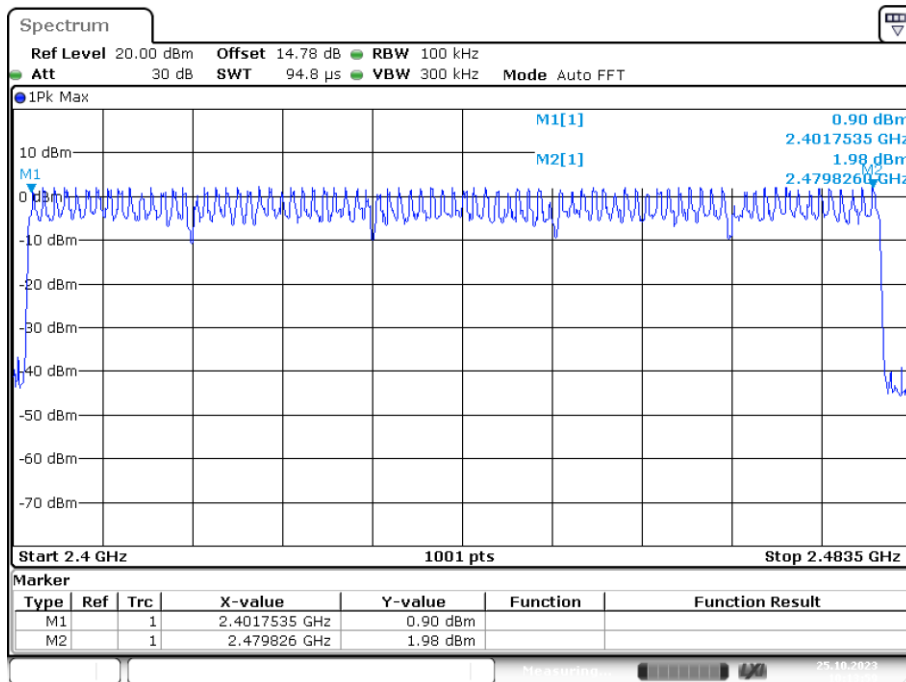

## 7. Dwell Time

### 7.1. Test limit

Please refer FCC part 15.247 & RSS-247.

Frequency hopping systems operating in the 2400MHz-2483.5 MHz. The average time of occupancy on any frequency shall not greater than 0.4 s within period of 0.4 seconds multiplied by the number of hopping channel employed.

### 7.2. Test Procedure

7.2.1. Place the EUT on the table and set it in transmitting mode.

7.2.2. Remove the antenna from the EUT and then connect a low loss RF cable from the antenna port to the spectrum analyzer.

7.2.3. Set center frequency of spectrum analyzer = operating frequency.

7.2.4. Set the spectrum analyzer as RBW, VBW=1MHz, Span = 0Hz, Sweep = auto.

7.2.5. Repeat above procedures until all frequency measured were complete.

### 7.3. Test Result

PASS.

Detailed information please see the following page.

| Condition | Mode  | Frequency (MHz) | Antenna | Pulse Time (ms) | Total Dwell Time (ms) | Burst Count | Period Time (ms) | Limit (ms) | Verdict |
|-----------|-------|-----------------|---------|-----------------|-----------------------|-------------|------------------|------------|---------|
| NVNT      | 1-DH1 | 2441            | Ant1    | 0.376           | 120.320               | 316         | 31600            | 400        | Pass    |
| NVNT      | 1-DH3 | 2441            | Ant1    | 1.631           | 260.960               | 155         | 31600            | 400        | Pass    |
| NVNT      | 1-DH5 | 2441            | Ant1    | 2.879           | 307.093               | 93          | 31600            | 400        | Pass    |
| NVNT      | 2-DH1 | 2441            | Ant1    | 0.385           | 123.200               | 315         | 31600            | 400        | Pass    |
| NVNT      | 2-DH3 | 2441            | Ant1    | 1.637           | 261.920               | 161         | 31600            | 400        | Pass    |
| NVNT      | 2-DH5 | 2441            | Ant1    | 2.885           | 307.733               | 110         | 31600            | 400        | Pass    |
| NVNT      | 3-DH1 | 2441            | Ant1    | 0.386           | 123.520               | 320         | 31600            | 400        | Pass    |
| NVNT      | 3-DH3 | 2441            | Ant1    | 1.636           | 261.760               | 154         | 31600            | 400        | Pass    |
| NVNT      | 3-DH5 | 2441            | Ant1    | 2.886           | 307.840               | 109         | 31600            | 400        | Pass    |

### Dwell NVNT 1-DH1 2441MHz Ant1 One Burst

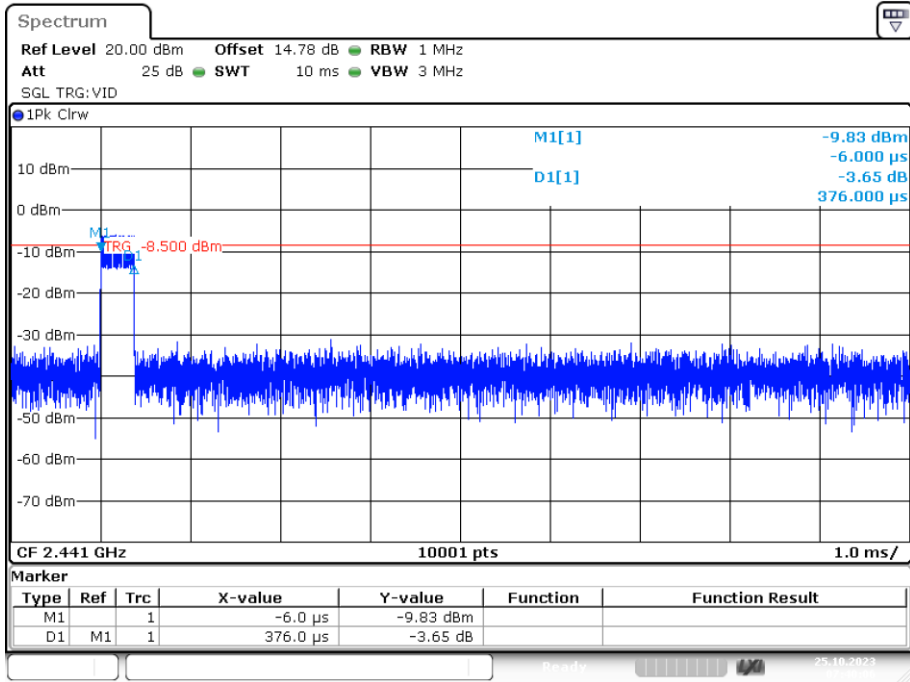

Date: 25.OCT.2023 07:40:06

### Dwell NVNT 1-DH1 2441MHz Ant1 Accumulated

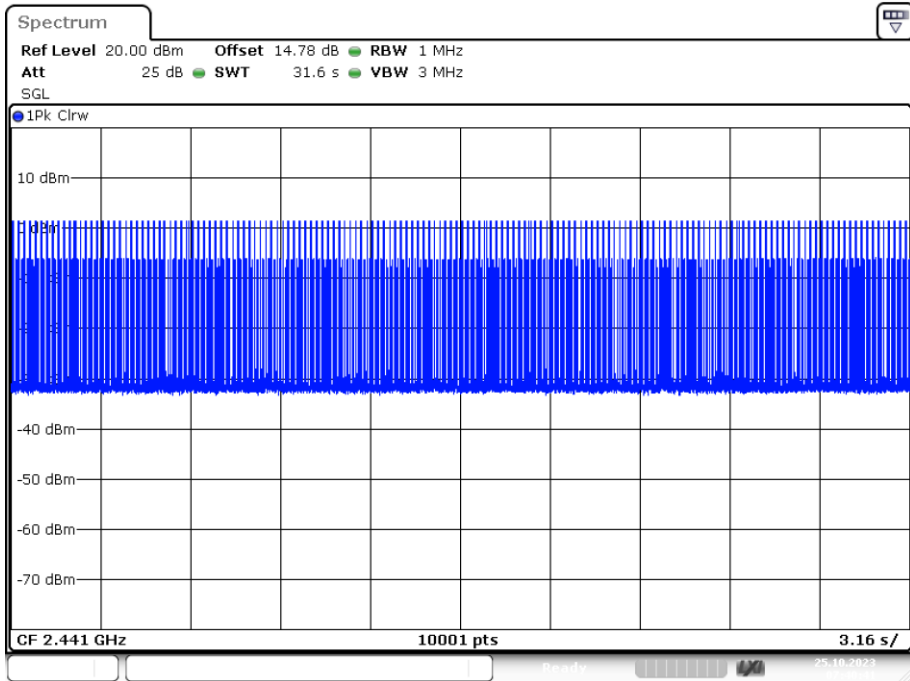

Date: 25.OCT.2023 07:40:41

### Dwell NVNT 1-DH3 2441MHz Ant1 One Burst

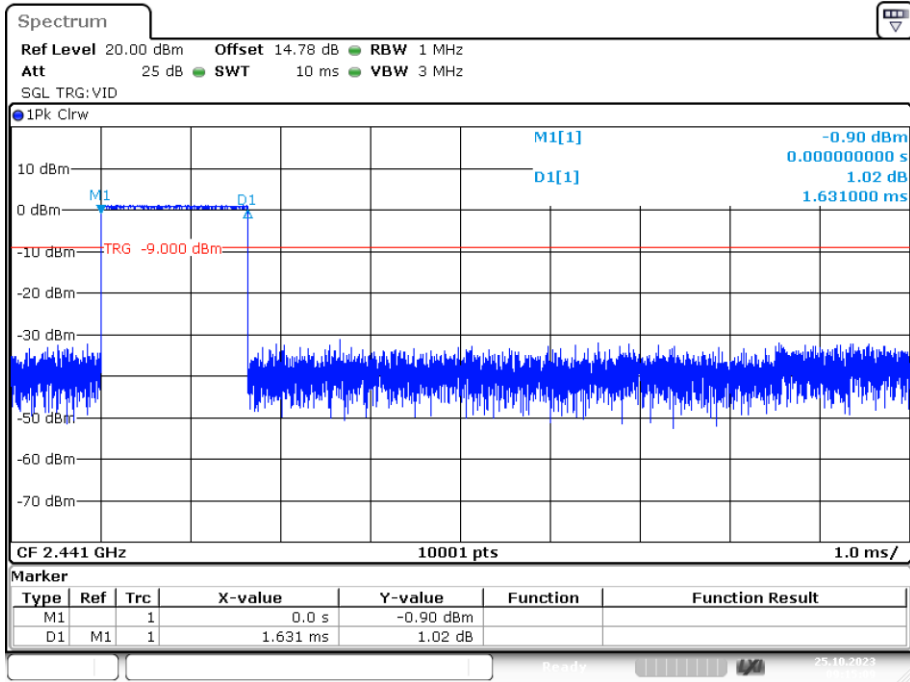

Date: 25.OCT.2023 09:15:09

### Dwell NVNT 1-DH3 2441MHz Ant1 Accumulated

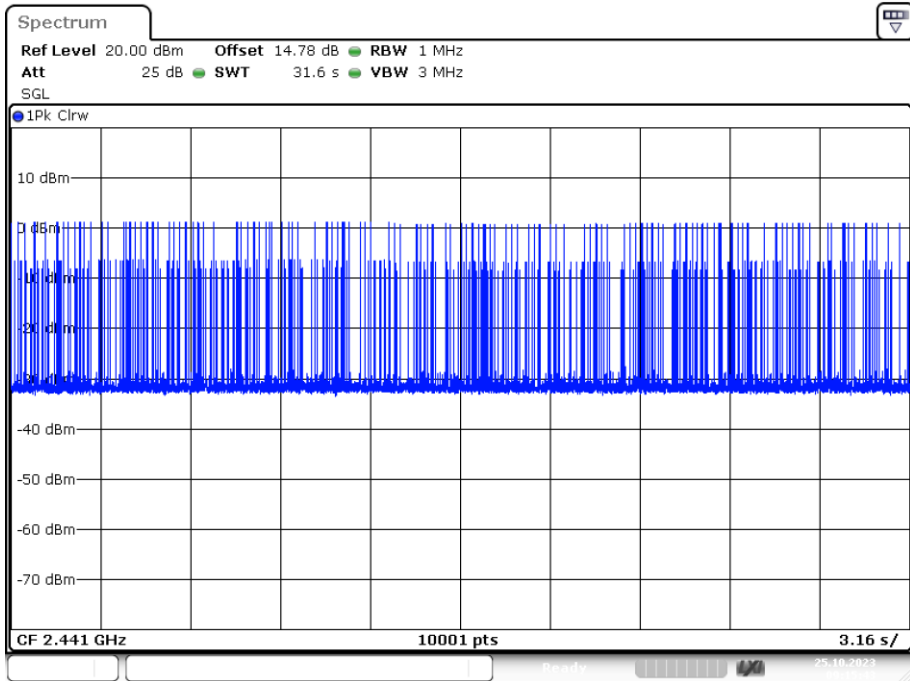

Date: 25.OCT.2023 09:15:43

### Dwell NVNT 1-DH5 2441MHz Ant1 One Burst

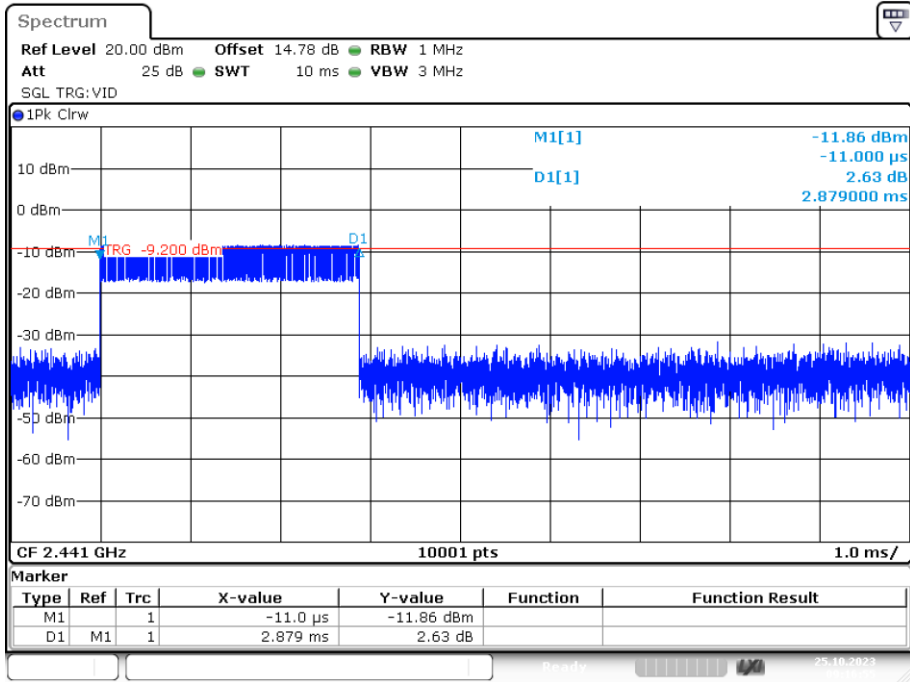

Date: 25.OCT.2023 09:16:55

### Dwell NVNT 1-DH5 2441MHz Ant1 Accumulated

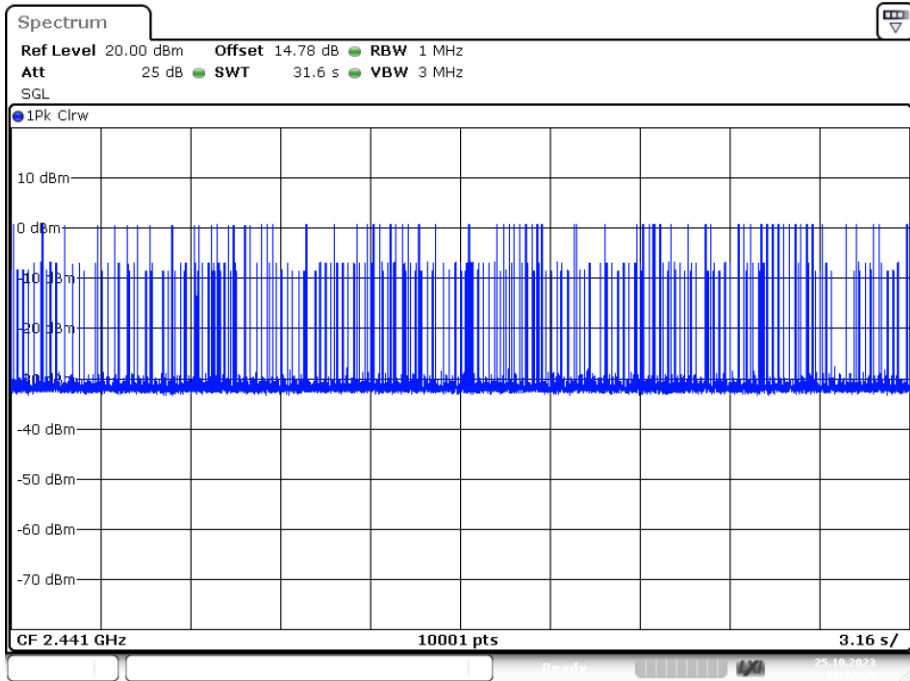

Date: 25.OCT.2023 09:17:29

### Dwell NVNT 2-DH1 2441MHz Ant1 One Burst

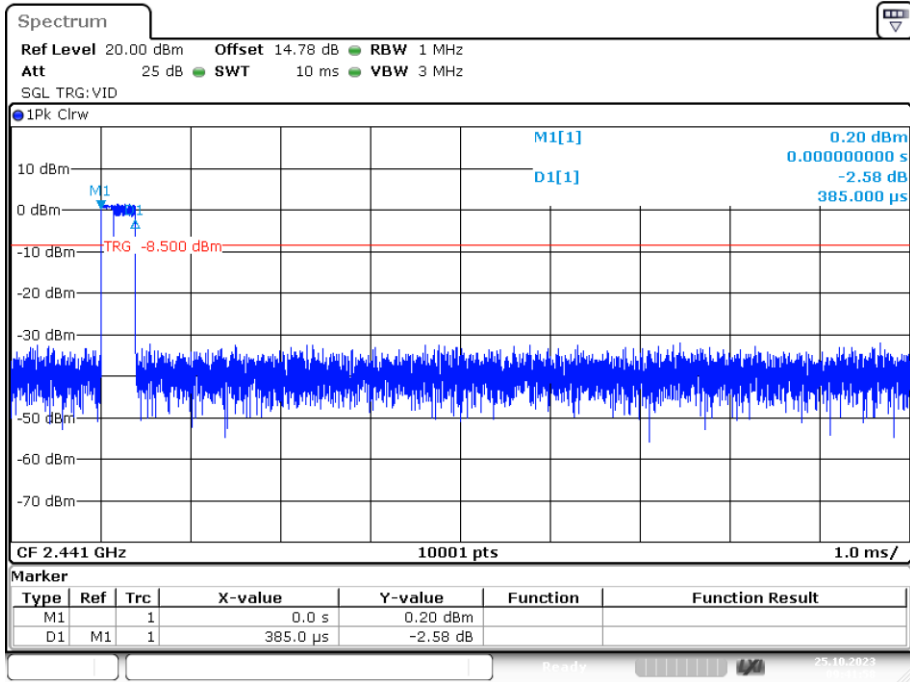

Date: 25.OCT.2023 09:41:58

### Dwell NVNT 2-DH1 2441MHz Ant1 Accumulated

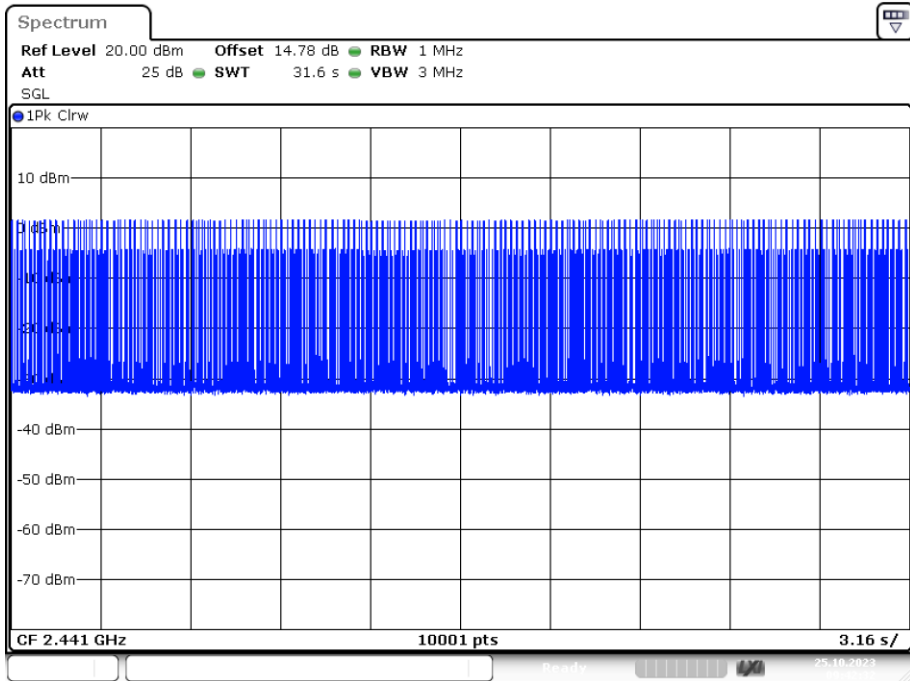

Date: 25.OCT.2023 09:42:32



### Dwell NVNT 2-DH3 2441MHz Ant1 One Burst

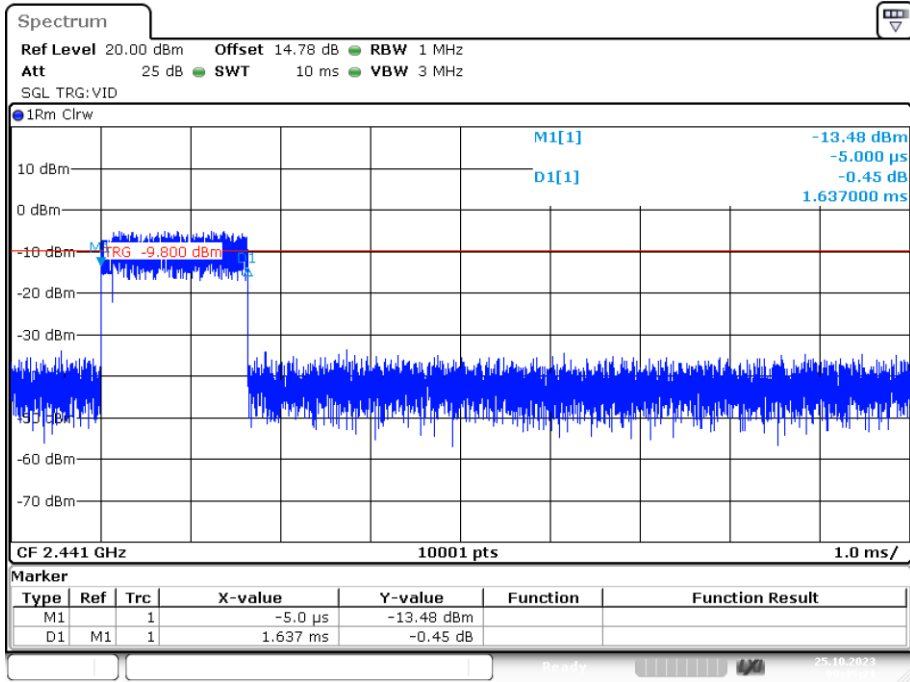

Date: 25.OCT.2023 09:45:20

### Dwell NVNT 2-DH3 2441MHz Ant1 Accumulated

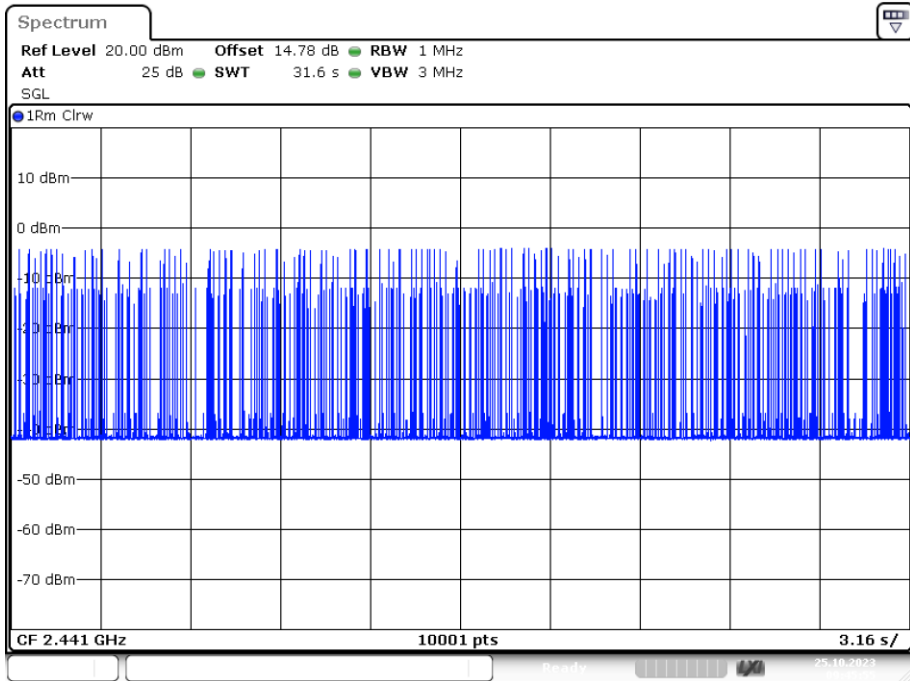

Date: 25.OCT.2023 09:45:55

### Dwell NVNT 2-DH5 2441MHz Ant1 One Burst

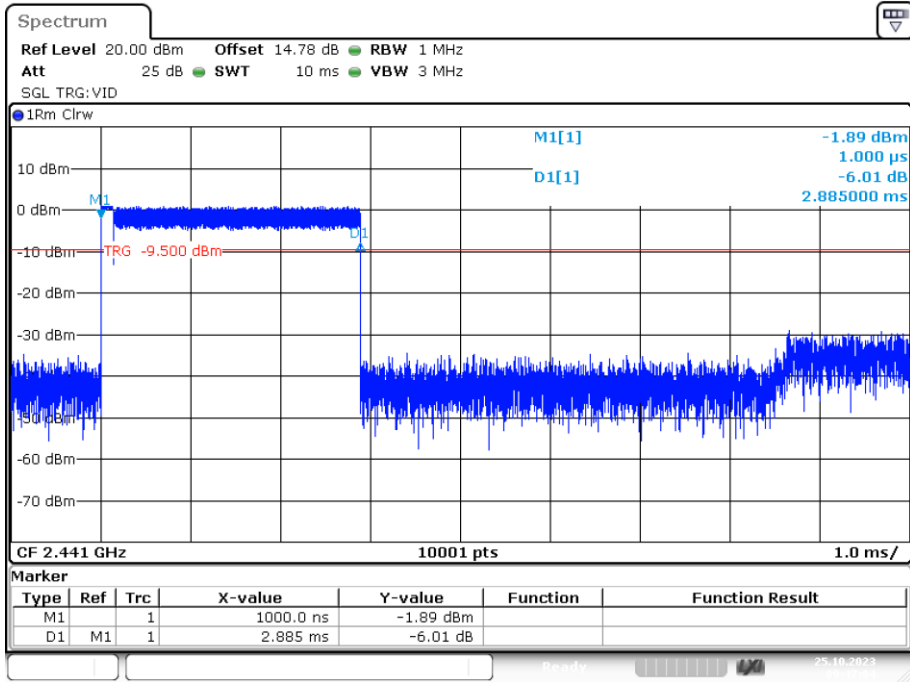

Date: 25.OCT.2023 09:47:04

### Dwell NVNT 2-DH5 2441MHz Ant1 Accumulated

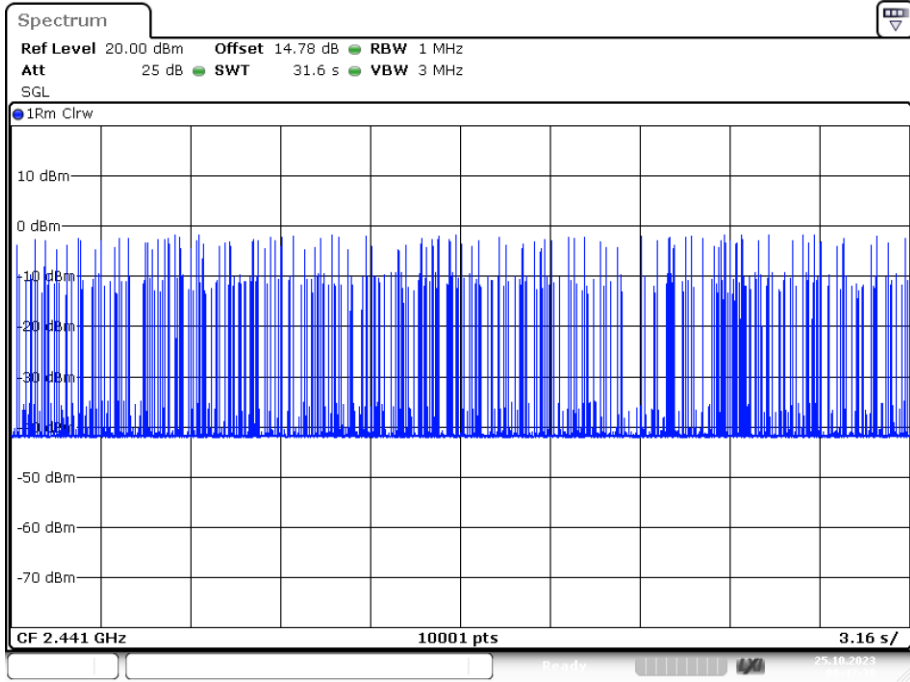

Date: 25.OCT.2023 09:47:39

### Dwell NVNT 3-DH1 2441MHz Ant1 One Burst

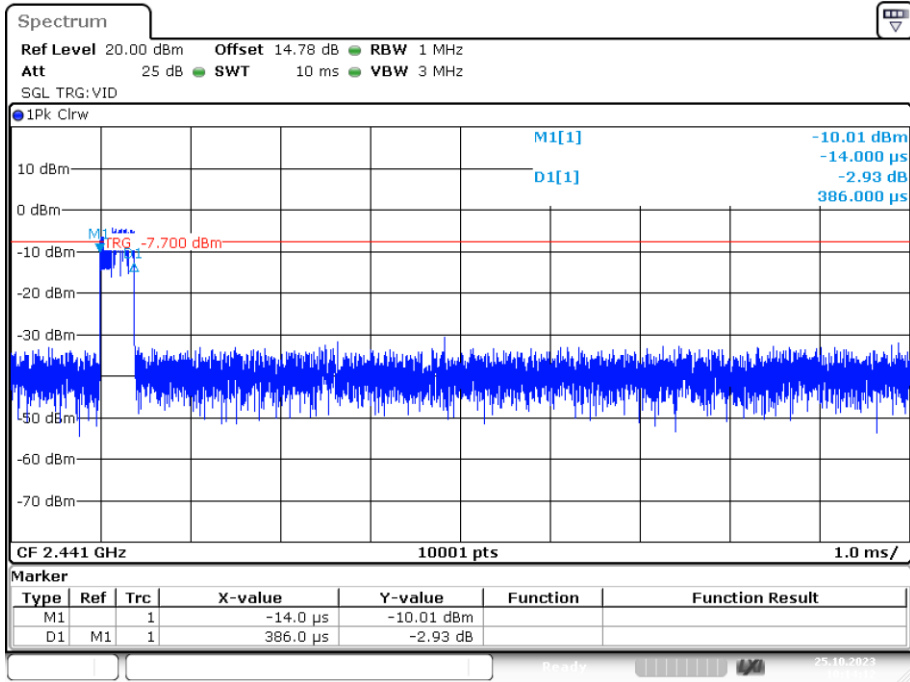

Date: 25.OCT.2023 10:14:12

### Dwell NVNT 3-DH1 2441MHz Ant1 Accumulated

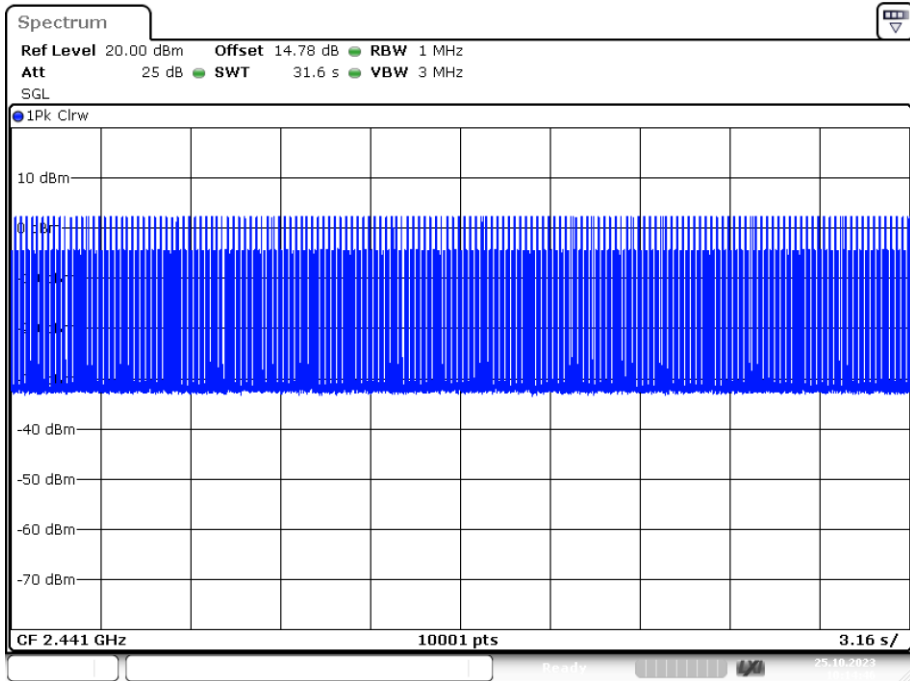

Date: 25.OCT.2023 10:14:46

### Dwell NVNT 3-DH3 2441MHz Ant1 One Burst

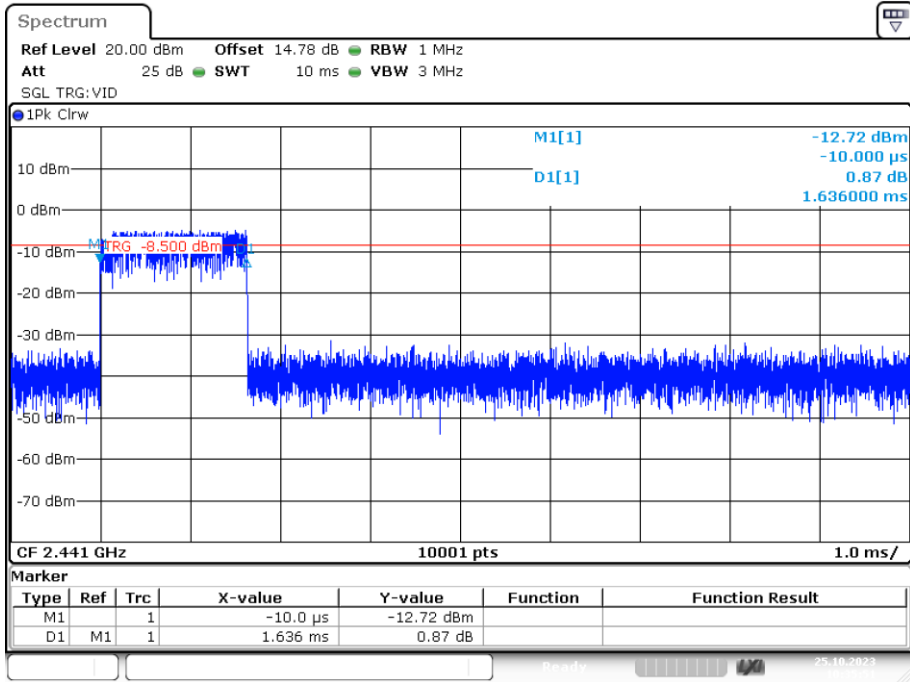

Date: 25.OCT.2023 10:35:51

### Dwell NVNT 3-DH3 2441MHz Ant1 Accumulated

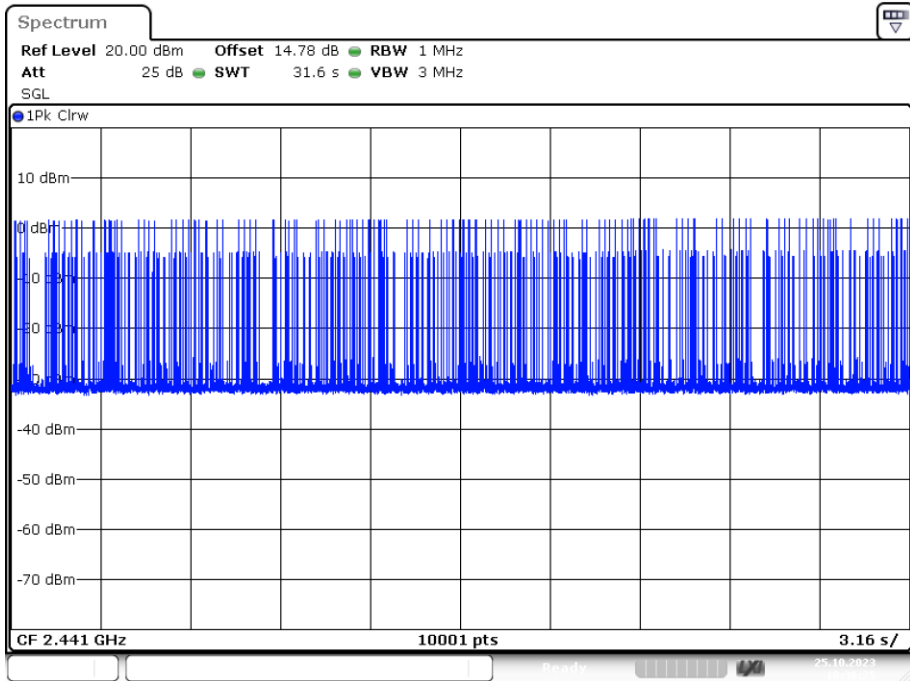

Date: 25.OCT.2023 10:36:25

Dwell NVNT 3-DH5 2441MHz Ant1 One Burst

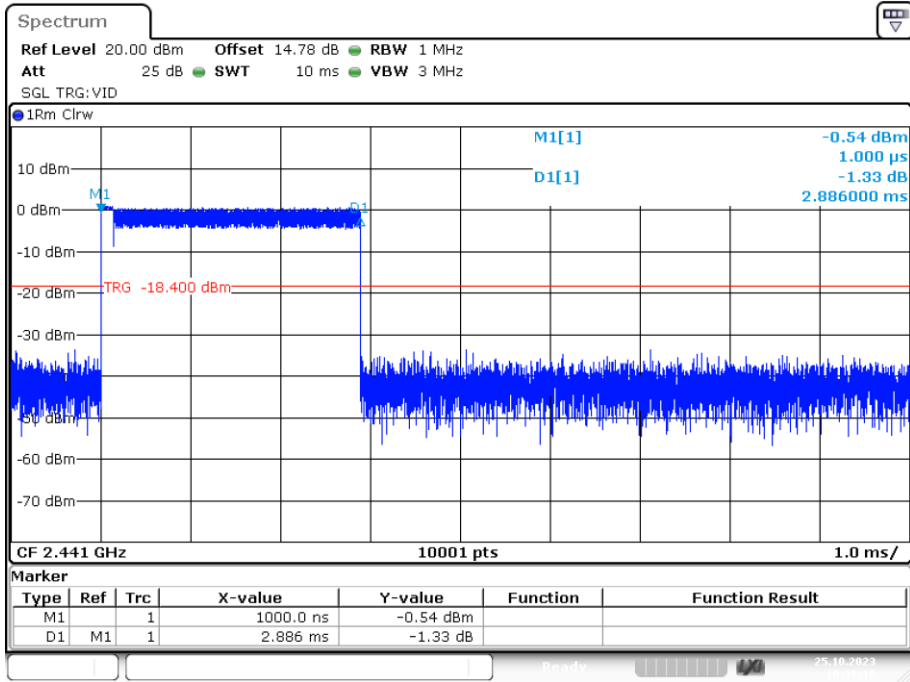

Date: 25.OCT.2023 10:38:10

Dwell NVNT 3-DH5 2441MHz Ant1 Accumulated

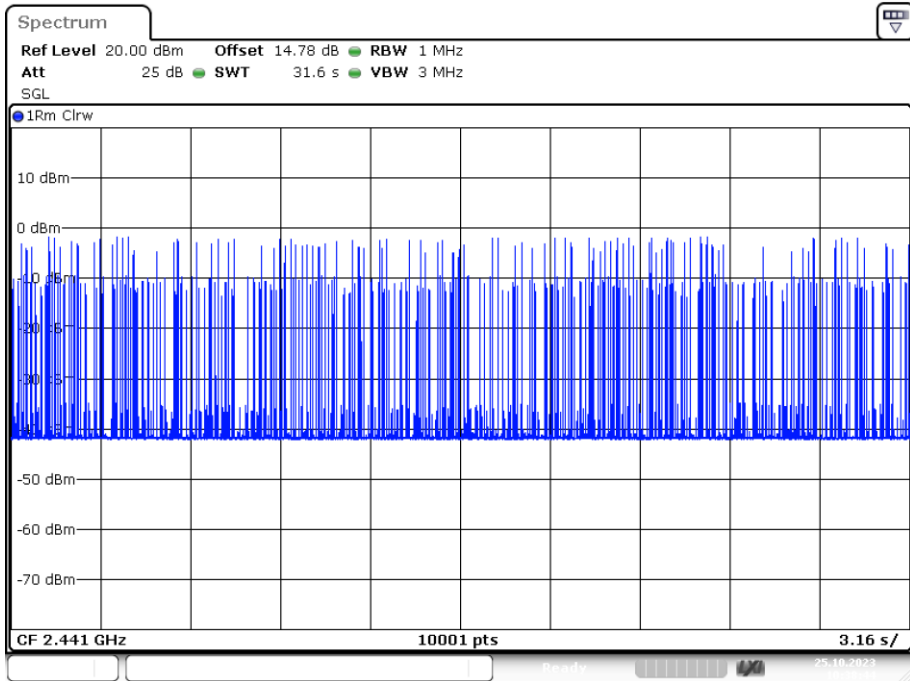

Date: 25.OCT.2023 10:38:44

## 8. Radiated Emissions

### 8.1. Limit

All the emissions appearing within 15.205 restricted frequency bands shall not exceed the limits shown in 15.209, all the other emissions shall be at least 20dB below the fundamental emissions, or comply with 15.209 limits.

#### 15.205 Restricted frequency band

| MHz                        | MHz                   | MHz             | GHz              |
|----------------------------|-----------------------|-----------------|------------------|
| 0.090 - 0.110              | 16.42 - 16.423        | 399.9 - 410     | 4.5 - 5.15       |
| <sup>1</sup> 0.495 - 0.505 | 16.69475 - 16.69525   | 608 - 614       | 5.35 - 5.46      |
| 2.1735 - 2.1905            | 16.80425 - 16.80475   | 960 - 1240      | 7.25 - 7.75      |
| 4.125 - 4.128              | 25.5 - 25.67          | 1300 - 1427     | 8.025 - 8.5      |
| 4.17725 - 4.17775          | 37.5 - 38.25          | 1435 - 1626.5   | 9.0 - 9.2        |
| 4.20725 - 4.20775          | 73 - 74.6             | 1645.5 - 1646.5 | 9.3 - 9.5        |
| 6.215 - 6.218              | 74.8 - 75.2           | 1660 - 1710     | 10.6 - 12.7      |
| 6.26775 - 6.26825          | 108 - 121.94          | 1718.8 - 1722.2 | 13.25 - 13.4     |
| 6.31175 - 6.31225          | 123 - 138             | 2200 - 2300     | 14.47 - 14.5     |
| 8.291 - 8.294              | 149.9 - 150.05        | 2310 - 2390     | 15.35 - 16.2     |
| 8.362 - 8.366              | 156.52475 - 156.52525 | 2483.5 - 2500   | 17.7 - 21.4      |
| 8.37625 - 8.38675          | 156.7 - 156.9         | 2690 - 2900     | 22.01 - 23.12    |
| 8.41425 - 8.41475          | 162.0125 - 167.17     | 3260 - 3267     | 23.6 - 24.0      |
| 12.29 - 12.293             | 167.72 - 173.2        | 3332 - 3339     | 31.2 - 31.8      |
| 12.51975 - 12.52025        | 240 - 285             | 3345.8 - 3358   | 36.43 - 36.5     |
| 12.57675 - 12.57725        | 322 - 335.4           | 3600 - 4400     | ( <sup>2</sup> ) |

#### 15.209 Limit

| FREQUENCY<br>MHz | DISTANCE<br>Meters | FIELD STRENGTHS LIMIT   |                                   |
|------------------|--------------------|---|-----------------------------------|
|                  |                    | $\mu\text{V}/\text{m}$  | $\text{dB}(\mu\text{V})/\text{m}$ |
| 0.009-0.490      | 300                | 2400/F(KHz)   | /                                 |
| 0.490-1.705      | 30                 | 24000/F(KHz)  | /                                 |
| 1.705-30         | 30                 | 30  | 29.5                              |
| 30 ~ 88          | 3                  | 100   | 40.0                              |
| 88 ~ 216         | 3                  | 150   | 43.5                              |
| 216 ~ 960        | 3                  | 200   | 46.0                              |
| 960 ~ 1000       | 3                  | 500   | 54.0                              |
| Above            | 1000               | 74.0 dB( $\mu\text{V}$ )/m (Peak)<br>54.0 dB( $\mu\text{V}$ )/m (Average) |                                   |

Note: The peak limit is 20 dB higher than the average limit

## 8.2. Block Diagram of Test setup

### 8.2.1 In 3m Anechoic Chamber Test Setup Diagram for below 30MHz

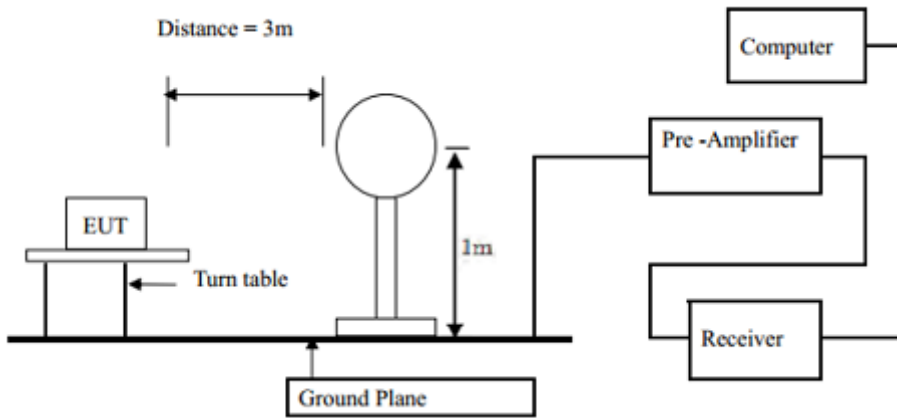

### 8.2.1 In 3m Anechoic Chamber Test Setup Diagram for below 1GHz

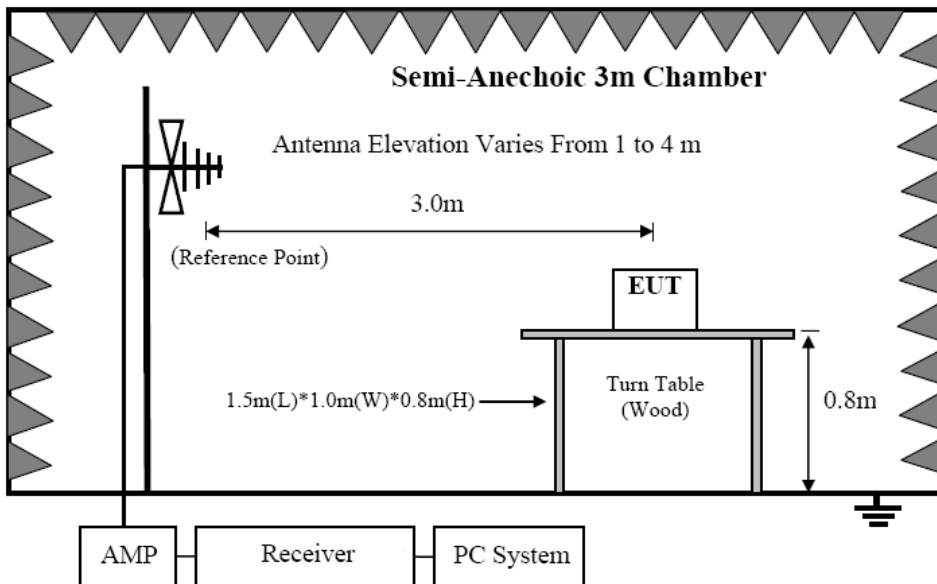

### 8.2.2 In 3m Anechoic Chamber Test Setup Diagram for frequency above 1GHz

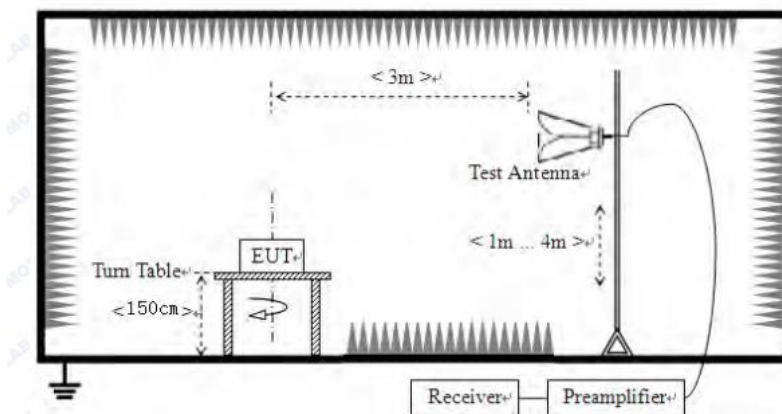

Note: For harmonic emissions test a appropriate high pass filter was inserted in the input port of AMP.

### 8.3. Test Procedure

- (1) EUT was placed on a non-metallic table, 80 cm above the ground plane inside a semi-anechoic chamber.
- (2) Setup EUT and simulator
- (3) Test antenna was located 3m from the EUT on an adjustable mast. Below pre-scan procedure was first performed in order to find prominent radiated emissions.
  - (a) Change work frequency or channel of device if practicable.
  - (b) Change modulation type of device if practicable.
  - (c) Rotated EUT though three orthogonal axes to determine the attitude of EUT arrangement produces highest emissions
- (4) Spectrum frequency from 9KHz to 25GHz (tenth harmonic of fundamental frequency) was investigated
- (5) For final emissions measurements at each frequency of interest, the EUT were rotated and the antenna height was varied between 1m and 4m in order to maximize the emission. Measurements in both horizontal and vertical polarities were made and the data was recorded. In order to find the maximum emission, the relative positions of equipments and all of the interface cables were changed according to ANSI C63.10 :2013on Radiated Emission test.
- (6) For emissions above 1GHz, both Peak and Average level were measured with Spectrum Analyzer, and the RBW is set at 1MHz, VBW is set at 3MHz for Peak measure; RBW is set at 1MHz, VBW is set at 10Hz for Average measure.

### 8.4. Test Result

We have scanned from 9kHz to the 10th harmonic of the EUT's highest frequency.  
Detailed information please see the following page.

From 9KHz to 30MHz: Conclusion: PASS

Note: The amplitude of spurious emissions which are attenuated by more than 20dB below the permissible value has no need to be reported.



From 30MHz to 1000MHz: Conclusion: PASS

Vertical:

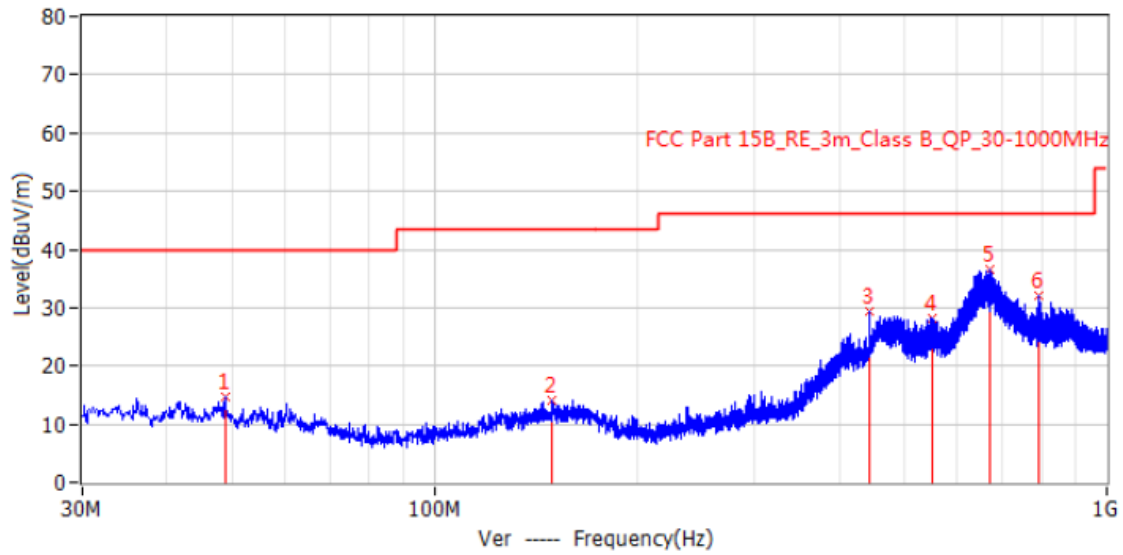

| No. | Frequency  | Limit dBuV/m | Level dBuV/m | Margin dB | Factor dB/m | Detector | Polar | Height cm | Angle deg |
|-----|------------|--------------|--------------|-----------|-------------|----------|-------|-----------|-----------|
| 1*  | 48.915MHz  | 40.0         | 14.6         | -25.4     | 15.9        | PK       | Ver   | 100.0     | 191.0     |
| 2*  | 149.674MHz | 43.5         | 14.1         | -29.4     | 15.6        | PK       | Ver   | 100.0     | 166.0     |
| 3*  | 444.675MHz | 46.0         | 29.4         | -16.6     | 17.7        | PK       | Ver   | 100.0     | 263.0     |
| 4*  | 549.435MHz | 46.0         | 28.1         | -17.9     | 19.8        | PK       | Ver   | 100.0     | 88.0      |
| 5*  | 670.806MHz | 46.0         | 36.5         | -9.5      | 22.0        | PK       | Ver   | 100.0     | 97.0      |
| 6*  | 790.601MHz | 46.0         | 32.0         | -14.0     | 24.0        | PK       | Ver   | 100.0     | 25.0      |

**Horizontal:**

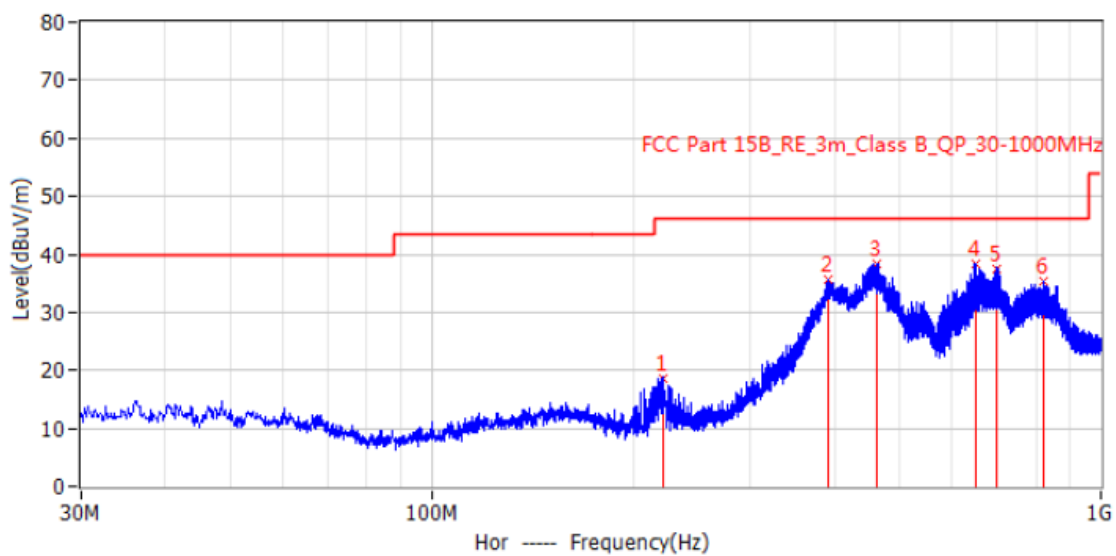

| No. | Frequency  | Limit dBuV/m | Level dBuV/m | Margin dB | Factor dB/m | Detector | Polar | Height cm | Angle deg |
|-----|------------|--------------|--------------|-----------|-------------|----------|-------|-----------|-----------|
| 1*  | 221.939MHz | 46.0         | 18.7         | -27.3     | 11.9        | PK       | Hor   | 100.0     | 0.0       |
| 2*  | 391.568MHz | 46.0         | 35.6         | -10.4     | 16.5        | PK       | Hor   | 100.0     | 0.0       |
| 3*  | 461.408MHz | 46.0         | 38.5         | -7.5      | 18.0        | PK       | Hor   | 100.0     | 0.0       |
| 4*  | 649.951MHz | 46.0         | 38.5         | -7.5      | 21.8        | PK       | Hor   | 135.0     | 0.0       |
| 5*  | 696.754MHz | 46.0         | 37.6         | -8.4      | 22.3        | PK       | Hor   | 127.0     | 0.0       |
| 6*  | 823.096MHz | 46.0         | 35.3         | -10.7     | 24.3        | PK       | Hor   | 100.0     | 336.0     |

Remark: All modes have been tested, and only worst data of GFSK mode, Channel 2441MHz was listed in this report.

From 1G-25GHz

| Test Mode: GFSK TX Low  |                     |             |                       |                |                 |                 |                |             |        |
|---|---------------------|-------------|-----------------------|----------------|-----------------|-----------------|----------------|-------------|--------|
| Freq (MHz)  | Read Level (dBuV/m) | Polar (H/V) | Antenna Factor (dB/m) | Cable loss(dB) | Amp Factor (dB) | Result (dBuV/m) | Limit (dBuV/m) | Margin (dB) | Remark |
| 4804  | 44.44               | V           | 33.95                 | 10.18          | 34.26           | 54.31           | 74             | -19.69      | PK     |
| 4804  | 36.31               | V           | 33.95                 | 10.18          | 34.26           | 46.18           | 54             | -7.82       | AV     |
| 7206  | /                   | /           | /                     | /              | /               | /               | /              | /           | /      |
| 9608  | /                   | /           | /                     | /              | /               | /               | /              | /           | /      |
| 4804  | 46.44               | H           | 33.95                 | 10.18          | 34.26           | 56.31           | 74             | -17.69      | PK     |
| 4804  | 36.77               | H           | 33.95                 | 10.18          | 34.26           | 46.64           | 54             | -7.36       | AV     |
| 7206  | /                   | /           | /                     | /              | /               | /               | /              | /           | /      |
| 9608  | /                   | /           | /                     | /              | /               | /               | /              | /           | /      |
| Test Mode: GFSK TX Mid  |                     |             |                       |                |                 |                 |                |             |        |
| 4882  | 42.10               | V           | 33.93                 | 10.2           | 34.29           | 51.94           | 74             | -22.06      | PK     |
| 4882  | 37.00               | V           | 33.93                 | 10.2           | 34.29           | 46.84           | 54             | -7.16       | AV     |
| 7323  | /                   | /           | /                     | /              | /               | /               | /              | /           | /      |
| 9764  | /                   | /           | /                     | /              | /               | /               | /              | /           | /      |
| 4882  | 44.13               | H           | 33.93                 | 10.2           | 34.29           | 53.97           | 74             | -20.03      | PK     |
| 4882  | 34.66               | H           | 33.93                 | 10.2           | 34.29           | 44.50           | 54             | -9.50       | AV     |
| 7323  | /                   | /           | /                     | /              | /               | /               | /              | /           | /      |
| 9764  | /                   | /           | /                     | /              | /               | /               | /              | /           | /      |
| Test Mode: GFSK TX High   |                     |             |                       |                |                 |                 |                |             |        |
| 4960  | 44.73               | V           | 33.93                 | 10.2           | 34.29           | 54.57           | 74             | -19.43      | PK     |
| 4960  | 34.15               | V           | 33.93                 | 10.2           | 34.29           | 43.99           | 54             | -10.01      | AV     |
| 7440  | /                   | /           | /                     | /              | /               | /               | /              | /           | /      |
| 9920  | /                   | /           | /                     | /              | /               | /               | /              | /           | /      |
| 4960  | 43.05               | H           | 33.93                 | 10.2           | 34.29           | 52.89           | 74             | -21.11      | PK     |
| 4960  | 35.07               | H           | 33.93                 | 10.2           | 34.29           | 44.91           | 54             | -9.09       | AV     |
| 7440  | /                   | /           | /                     | /              | /               | /               | /              | /           | /      |
| 9920  | /                   | /           | /                     | /              | /               | /               | /              | /           | /      |
| Note:   |                     |             |                       |                |                 |                 |                |             |        |
| 1, Result = Read level + Antenna factor + cable loss-Amp factor                                   |                     |             |                       |                |                 |                 |                |             |        |
| 2, All the other emissions not reported were too low to read and deemed to comply with FCC limit. |                     |             |                       |                |                 |                 |                |             |        |

From 1G-25GHz

| Test Mode: $\pi/4$ DQPSK TX Low   |                     |             |                       |                |                 |                 |                |             |        |
|---|---------------------|-------------|-----------------------|----------------|-----------------|-----------------|----------------|-------------|--------|
| Freq (MHz)  | Read Level (dBuV/m) | Polar (H/V) | Antenna Factor (dB/m) | Cable loss(dB) | Amp Factor (dB) | Result (dBuV/m) | Limit (dBuV/m) | Margin (dB) | Remark |
| 4804  | 44.63               | V           | 33.95                 | 10.18          | 34.26           | 54.50           | 74             | -19.50      | PK     |
| 4804  | 35.56               | V           | 33.95                 | 10.18          | 34.26           | 45.43           | 54             | -8.57       | AV     |
| 7206  | /                   | /           | /                     | /              | /               | /               | /              | /           | /      |
| 9608  | /                   | /           | /                     | /              | /               | /               | /              | /           | /      |
| 4804  | 47.08               | H           | 33.95                 | 10.18          | 34.26           | 56.95           | 74             | -17.05      | PK     |
| 4804  | 36.07               | H           | 33.95                 | 10.18          | 34.26           | 45.94           | 54             | -8.06       | AV     |
| 7206  | /                   | /           | /                     | /              | /               | /               | /              | /           | /      |
| 9608  | /                   | /           | /                     | /              | /               | /               | /              | /           | /      |
| Test Mode: $\pi/4$ DQPSK TX Mid   |                     |             |                       |                |                 |                 |                |             |        |
| 4882  | 44.75               | V           | 33.93                 | 10.2           | 34.29           | 54.59           | 74             | -19.41      | PK     |
| 4882  | 34.64               | V           | 33.93                 | 10.2           | 34.29           | 44.48           | 54             | -9.52       | AV     |
| 7323  | /                   | /           | /                     | /              | /               | /               | /              | /           | /      |
| 9764  | /                   | /           | /                     | /              | /               | /               | /              | /           | /      |
| 4882  | 43.40               | H           | 33.93                 | 10.2           | 34.29           | 53.24           | 74             | -20.76      | PK     |
| 4882  | 35.90               | H           | 33.93                 | 10.2           | 34.29           | 45.74           | 54             | -8.26       | AV     |
| 7323  | /                   | /           | /                     | /              | /               | /               | /              | /           | /      |
| 9764  | /                   | /           | /                     | /              | /               | /               | /              | /           | /      |
| Test Mode: $\pi/4$ DQPSK TX High  |                     |             |                       |                |                 |                 |                |             |        |
| 4960  | 44.43               | V           | 33.93                 | 10.2           | 34.29           | 54.27           | 74             | -19.73      | PK     |
| 4960  | 35.12               | V           | 33.93                 | 10.2           | 34.29           | 44.96           | 54             | -9.04       | AV     |
| 7440  | /                   | /           | /                     | /              | /               | /               | /              | /           | /      |
| 9920  | /                   | /           | /                     | /              | /               | /               | /              | /           | /      |
| 4960  | 44.18               | H           | 33.93                 | 10.2           | 34.29           | 54.02           | 74             | -19.98      | PK     |
| 4960  | 32.71               | H           | 33.93                 | 10.2           | 34.29           | 42.55           | 54             | -11.45      | AV     |
| 7440  | /                   | /           | /                     | /              | /               | /               | /              | /           | /      |
| 9920  | /                   | /           | /                     | /              | /               | /               | /              | /           | /      |
| Note:   |                     |             |                       |                |                 |                 |                |             |        |
| 1, Result = Read level + Antenna factor + cable loss-Amp factor                                   |                     |             |                       |                |                 |                 |                |             |        |
| 2, All the other emissions not reported were too low to read and deemed to comply with FCC limit. |                     |             |                       |                |                 |                 |                |             |        |

From 1G-25GHz

| Test Mode: 8DPSK TX Low   |                     |             |                       |                |                 |                 |                |             |        |
|---|---------------------|-------------|-----------------------|----------------|-----------------|-----------------|----------------|-------------|--------|
| Freq (MHz)  | Read Level (dBuV/m) | Polar (H/V) | Antenna Factor (dB/m) | Cable loss(dB) | Amp Factor (dB) | Result (dBuV/m) | Limit (dBuV/m) | Margin (dB) | Remark |
| 4804  | 44.79               | V           | 33.95                 | 10.18          | 34.26           | 54.66           | 74             | -19.34      | PK     |
| 4804  | 35.65               | V           | 33.95                 | 10.18          | 34.26           | 45.52           | 54             | -8.48       | AV     |
| 7206  | /                   | /           | /                     | /              | /               | /               | /              | /           | /      |
| 9608  | /                   | /           | /                     | /              | /               | /               | /              | /           | /      |
| 4804  | 44.87               | H           | 33.95                 | 10.18          | 34.26           | 54.74           | 74             | -19.26      | PK     |
| 4804  | 37.94               | H           | 33.95                 | 10.18          | 34.26           | 47.81           | 54             | -6.19       | AV     |
| 7206  | /                   | /           | /                     | /              | /               | /               | /              | /           | /      |
| 9608  | /                   | /           | /                     | /              | /               | /               | /              | /           | /      |
| Test Mode: 8DPSK TX Mid   |                     |             |                       |                |                 |                 |                |             |        |
| 4882  | 42.77               | V           | 33.93                 | 10.2           | 34.29           | 52.61           | 74             | -21.39      | PK     |
| 4882  | 33.20               | V           | 33.93                 | 10.2           | 34.29           | 43.04           | 54             | -10.96      | AV     |
| 7323  | /                   | /           | /                     | /              | /               | /               | /              | /           | /      |
| 9764  | /                   | /           | /                     | /              | /               | /               | /              | /           | /      |
| 4882  | 44.71               | H           | 33.93                 | 10.2           | 34.29           | 54.55           | 74             | -19.45      | PK     |
| 4882  | 34.25               | H           | 33.93                 | 10.2           | 34.29           | 44.09           | 54             | -9.91       | AV     |
| 7323  | /                   | /           | /                     | /              | /               | /               | /              | /           | /      |
| 9764  | /                   | /           | /                     | /              | /               | /               | /              | /           | /      |
| Test Mode: 8DPSK TX High  |                     |             |                       |                |                 |                 |                |             |        |
| 4960  | 45.35               | V           | 33.93                 | 10.2           | 34.29           | 55.19           | 74             | -18.81      | PK     |
| 4960  | 36.01               | V           | 33.93                 | 10.2           | 34.29           | 45.85           | 54             | -8.15       | AV     |
| 7440  | /                   | /           | /                     | /              | /               | /               | /              | /           | /      |
| 9920  | /                   | /           | /                     | /              | /               | /               | /              | /           | /      |
| 4960  | 42.60               | H           | 33.93                 | 10.2           | 34.29           | 52.44           | 74             | -21.56      | PK     |
| 4960  | 32.66               | H           | 33.93                 | 10.2           | 34.29           | 42.50           | 54             | -11.50      | AV     |
| 7440  | /                   | /           | /                     | /              | /               | /               | /              | /           | /      |
| 9920  | /                   | /           | /                     | /              | /               | /               | /              | /           | /      |
| Note:   |                     |             |                       |                |                 |                 |                |             |        |
| 1, Result = Read level + Antenna factor + cable loss-Amp factor                                   |                     |             |                       |                |                 |                 |                |             |        |
| 2, All the other emissions not reported were too low to read and deemed to comply with FCC limit. |                     |             |                       |                |                 |                 |                |             |        |

### Conducted RF Spurious Emission

#### Tx. Spurious NVNT 1-DH1 2402MHz Ant1 Emission

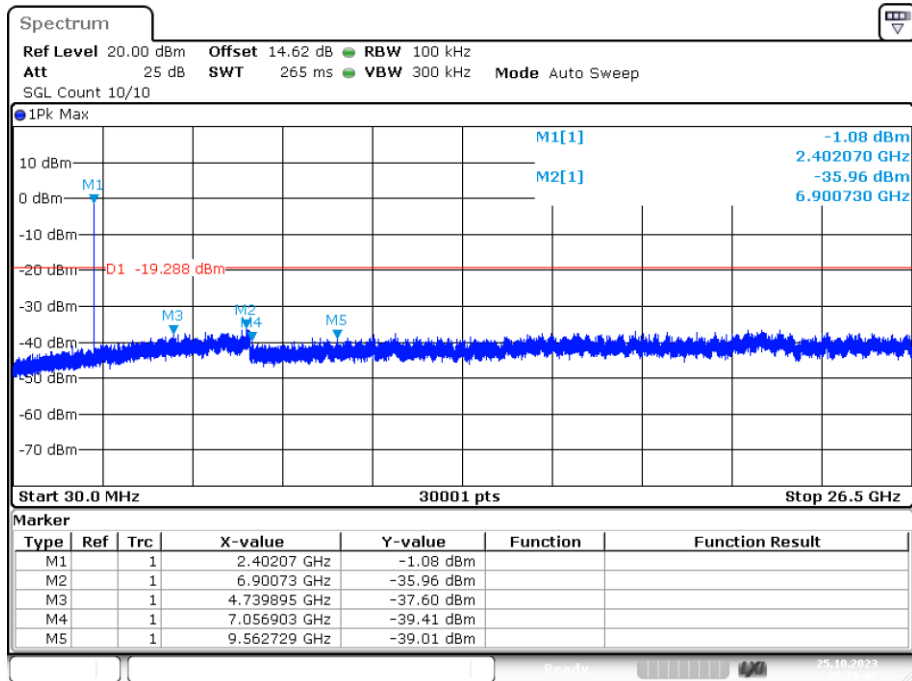

Date: 25.OCT.2023 07:29:07

#### Tx. Spurious NVNT 1-DH1 2441MHz Ant1 Emission

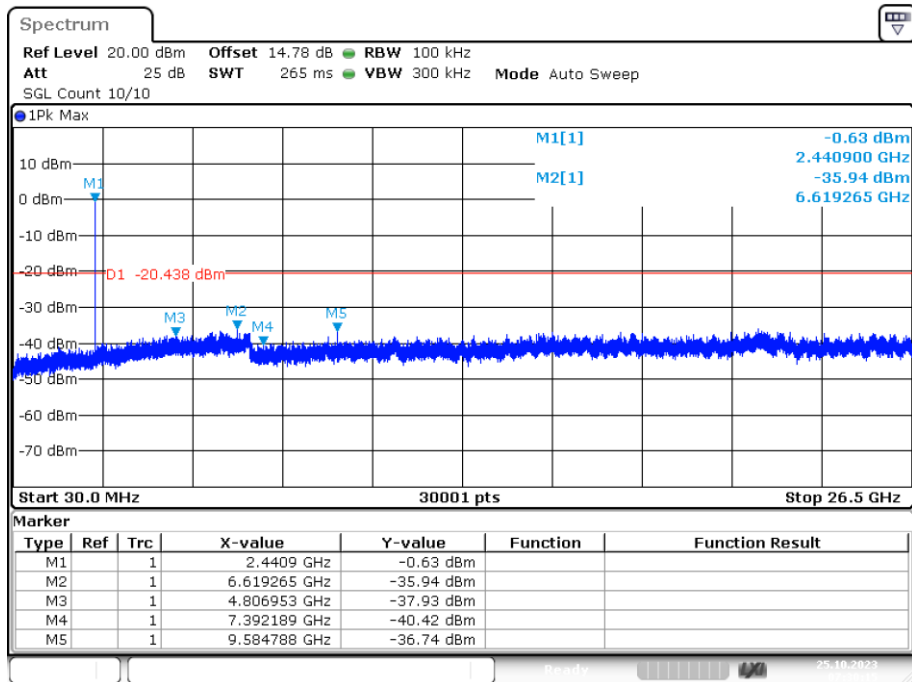

Date: 25.OCT.2023 07:30:15

Tx. Spurious NVNT 1-DH1 2480MHz Ant1 Emission

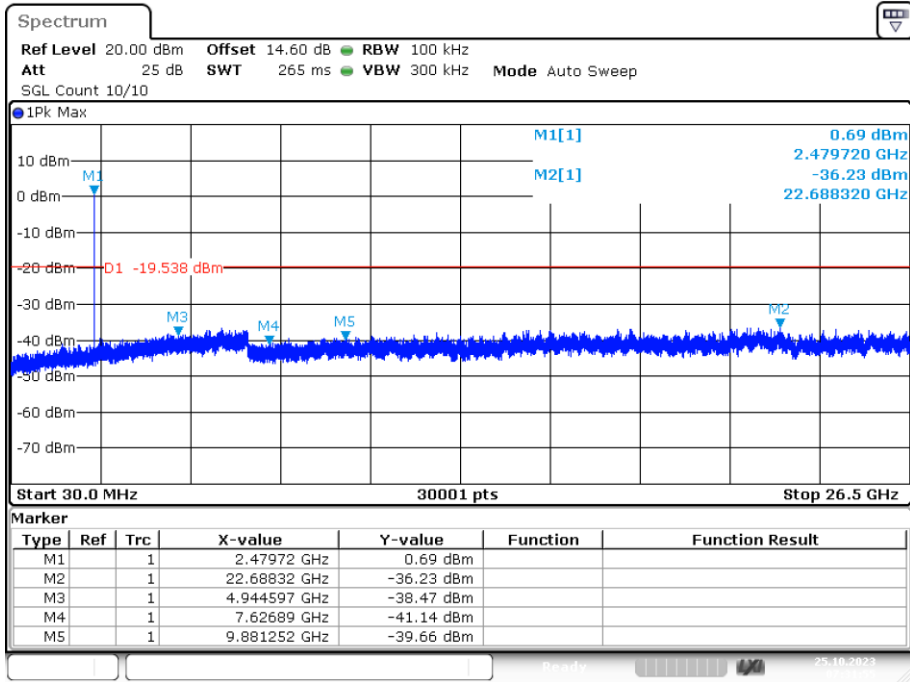

Tx. Spurious NVNT 2-DH1 2402MHz Ant1 Emission

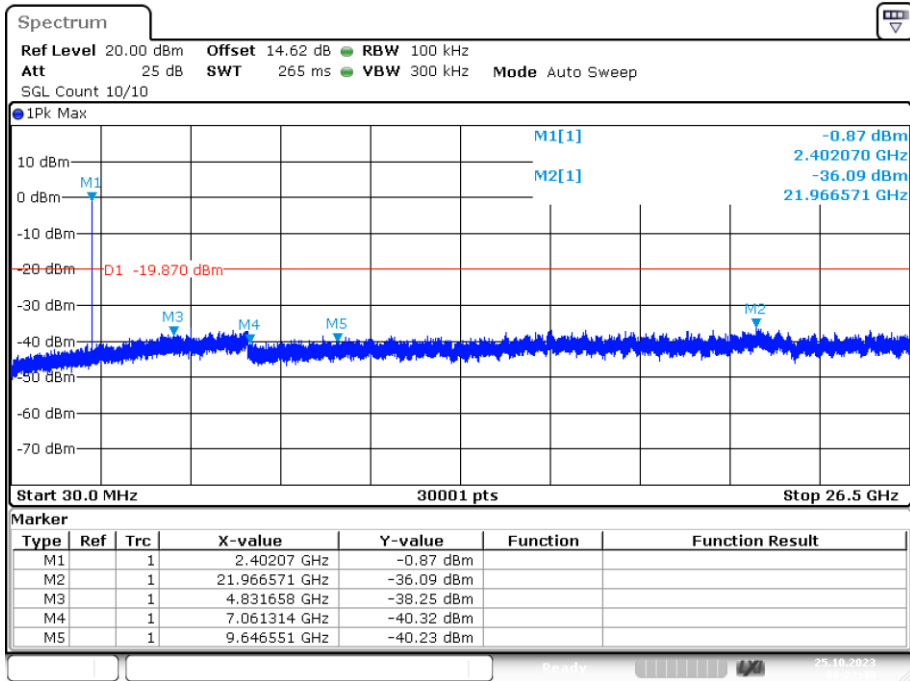

Tx. Spurious NVNT 2-DH1 2441MHz Ant1 Emission

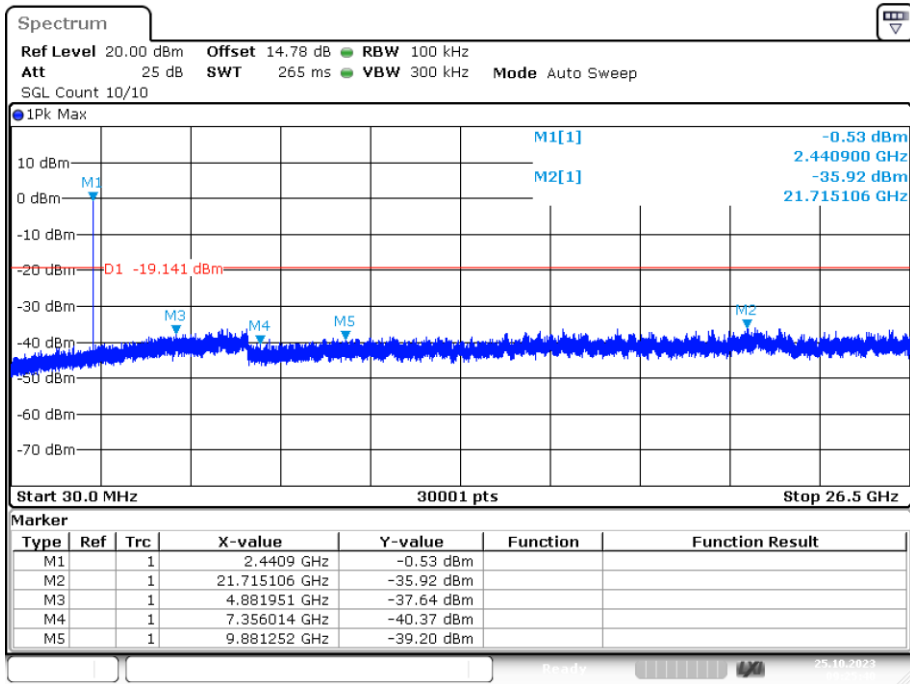

Tx. Spurious NVNT 2-DH1 2480MHz Ant1 Emission

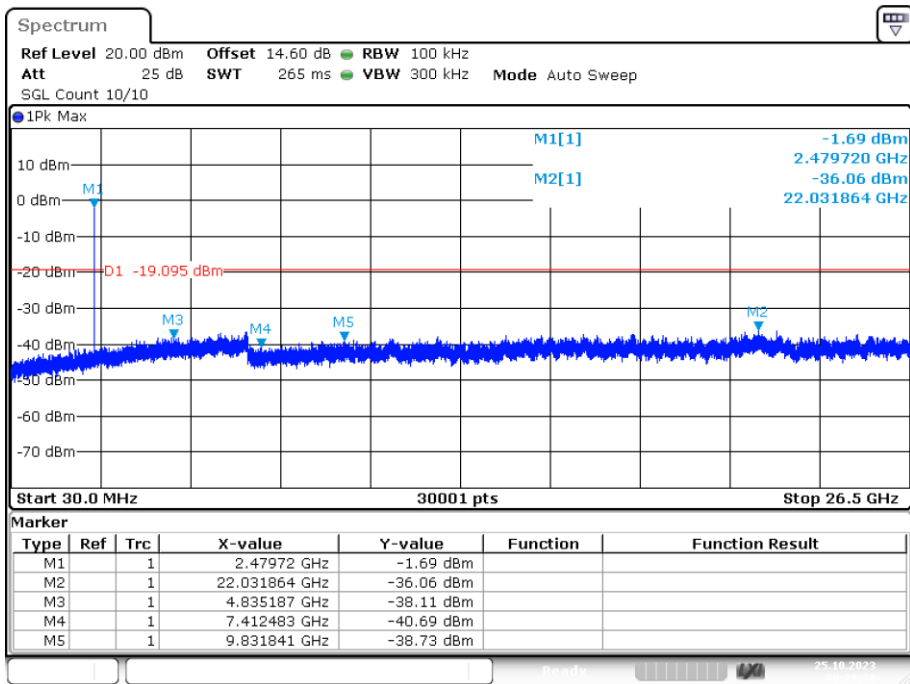



Tx. Spurious NVNT 3-DH1 2402MHz Ant1 Emission

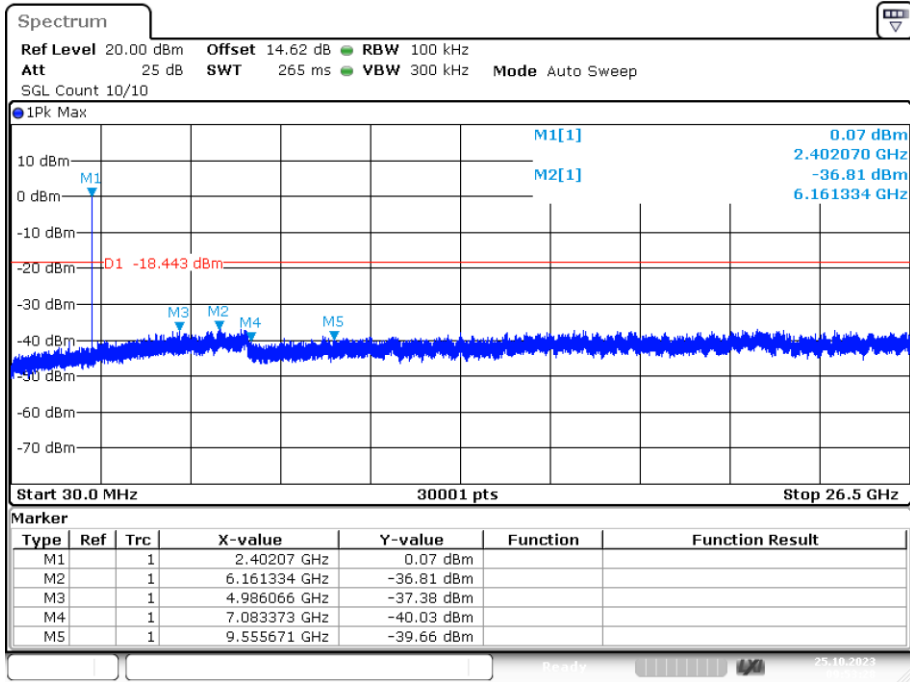

Tx. Spurious NVNT 3-DH1 2441MHz Ant1 Emission

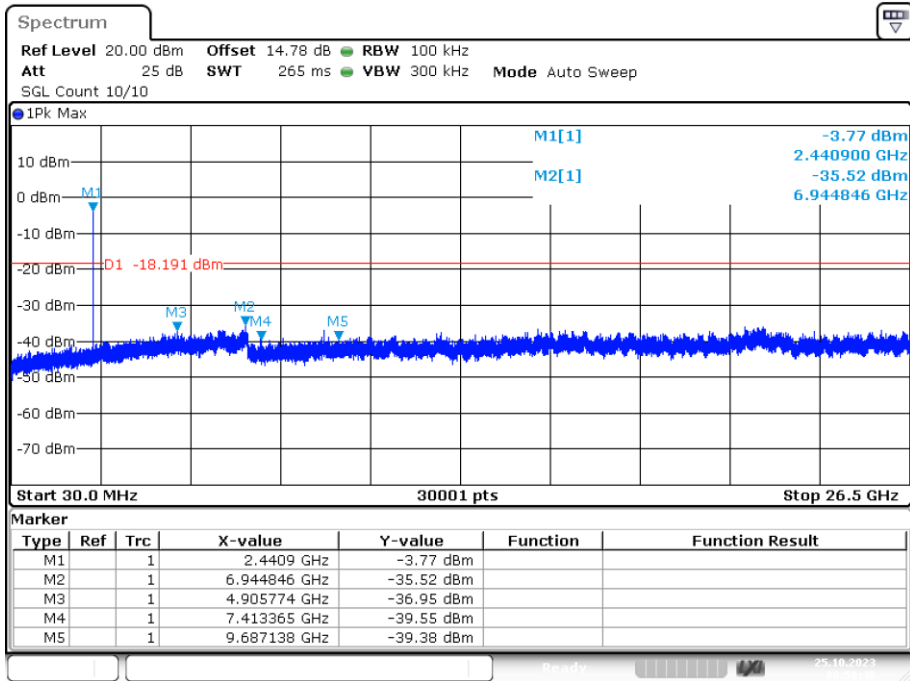

Tx. Spurious NVNT 3-DH1 2480MHz Ant1 Emission

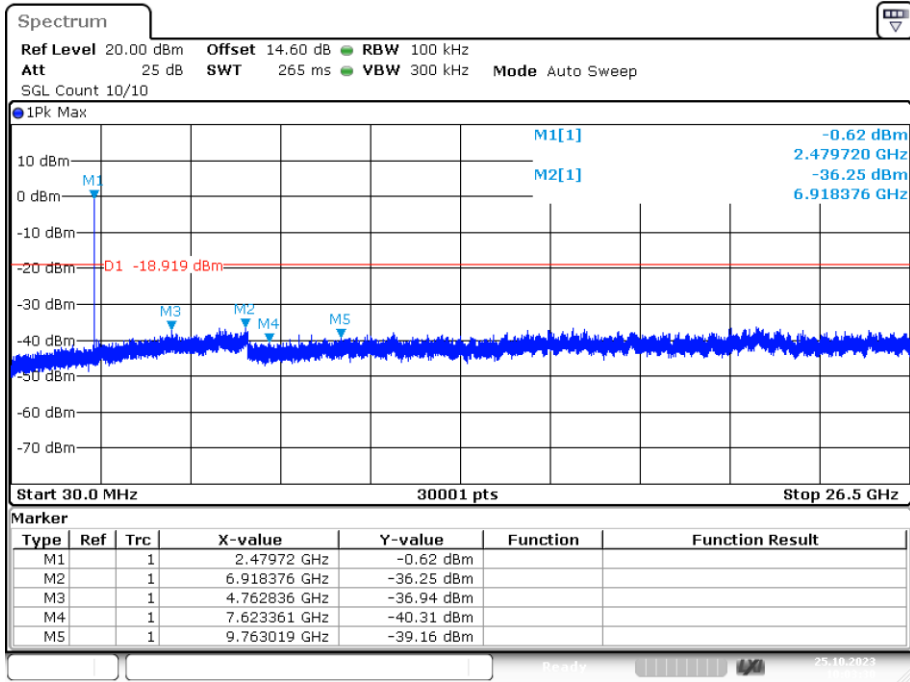

Date: 25.OCT.2023 10:03:31