

1.6X0.8X0.5 (mm) WiFi/Bluetooth Ceramic Chip Antenna (YF1608)

Engineering Specification

1. Product Number

YF 1608 F1 P 2G45

1 2 3 4 5



(1)Product Type	Chip Antenna
(2)Size Code	1.6X0.8 mm
(3)Type Code	F1
(4)Packing	Paper &Reel
(5)Frequency	2.45GHz



深圳市迎丰天线技术有限公司

SHEN ZHEN YINGFENG ANTENNA TECHNOLOGYCO.,LTD

Prepared by : JIEXI

Designed by : Jason

Checked by : Jason

Approved by : MR.FANG

TITLE : 1.6 x0.8x 0.8(mm) WiFi/Bluetooth Ceramic Chip
Antenna (YF1608) Engineering Specification

DOCUMENT
NO.

YF1608F1P2G45

REV.
C

2. Features

- *Stable and reliable in performances
- *Low temperature coefficient of frequency
- *Low profile, compact size
- *RoHS compliance
- *SMT processes compatible

3. Applications

- *Bluetooth earphone systems
- *Hand-held devices when WiFi /Bluetooth functions are needed, e.g., Smart phone.
- *IEEE802.11 b/g/n
- *ZigBee
- *Wireless PCMCIA cards or USB dongle

4. Description

Yingfeng chip antenna series are specially designed for WiFi/Bluetooth applications. Based on yingfeng proprietary design and processes, this chip antenna has excellent stability and sensitivity to consistently provide high signal reception efficiency.

5. Electrical Specifications (80 x 40 mm² ground plane)

5-1. Electrical Table

Characteristics		Specifications	Unit
Outline Dimensions		1.6x0.8x0.8	mm
Working Frequency		2400~2500	MHz
VSWR		2 Max.	
Impedance		50	Ω
Polarization		Linear Polarization	
Gain	Peak	2.5 (typical)	dBi
	Efficiency	58 (typical)	%



深圳市迎丰天线技术有限公司

SHEN ZHEN YINGFENG ANTENNA TECHNOLOGYCO.,LTD

Prepared by : JIEXI

Designed by : Jason

Checked by : Jason

Approved by : MR.FANG

TITLE : 1.6 x0.8x 0.8(mm) WiFi/Bluetooth Ceramic Chip
Antenna (YF1608) Engineering Specification

DOCUMENT
NO.

YF1608F1P2G45

REV.
C

5-2. Return Loss & VSWR

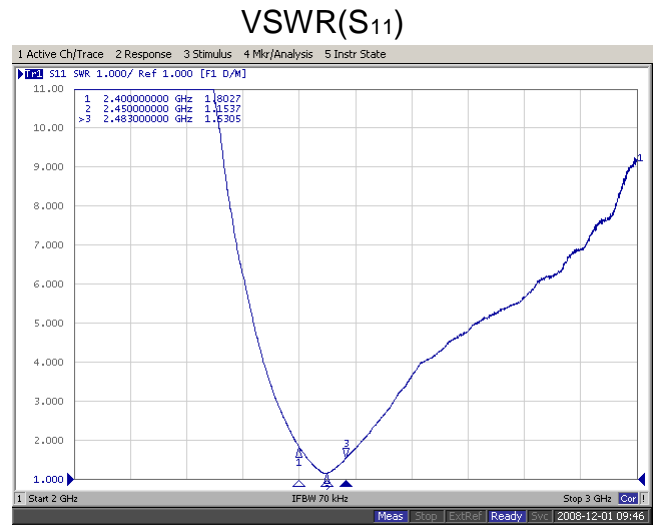
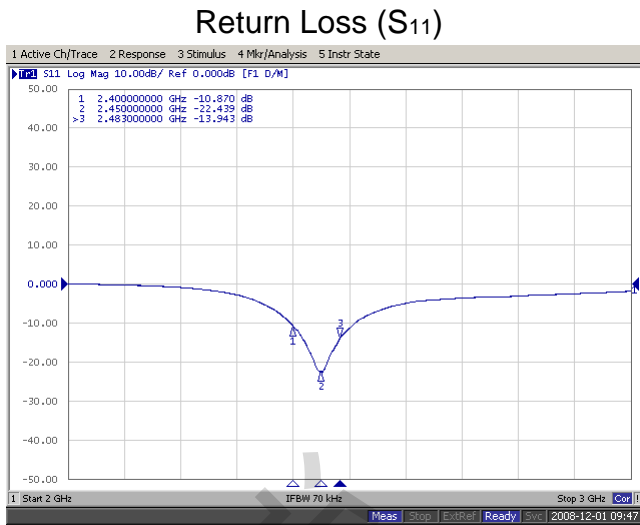

6. Antenna Dimensions & Test Board (unit: mm)

a. Antenna Dimensions

Dimensions (Unit: mm)

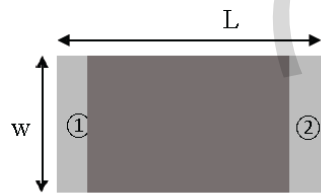

(Top View)

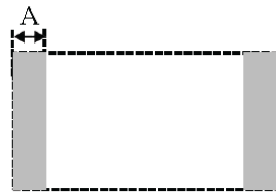

(Bottom View)

Number	Terminal Name
①	INPUT
②	NC



(Side View)

Symbols	L	W	T	A
Dimensions	1.60±0.20	0.80±0.20	0.80±0.20	0.30±0.10



深圳市迎丰天线技术有限公司

SHEN ZHEN YINGFENG ANTENNA TECHNOLOGY CO., LTD

Prepared by : JIEXI

Designed by : Jason

Checked by : Jason

Approved by : MR.FANG

TITLE : 1.6 x0.8x 0.8(mm) WiFi/Bluetooth Ceramic Chip
Antenna (YF1608) Engineering Specification

DOCUMENT
NO.

YF1608F1P2G45

REV.
C

b. Test Board with Antenna

Unit: mm

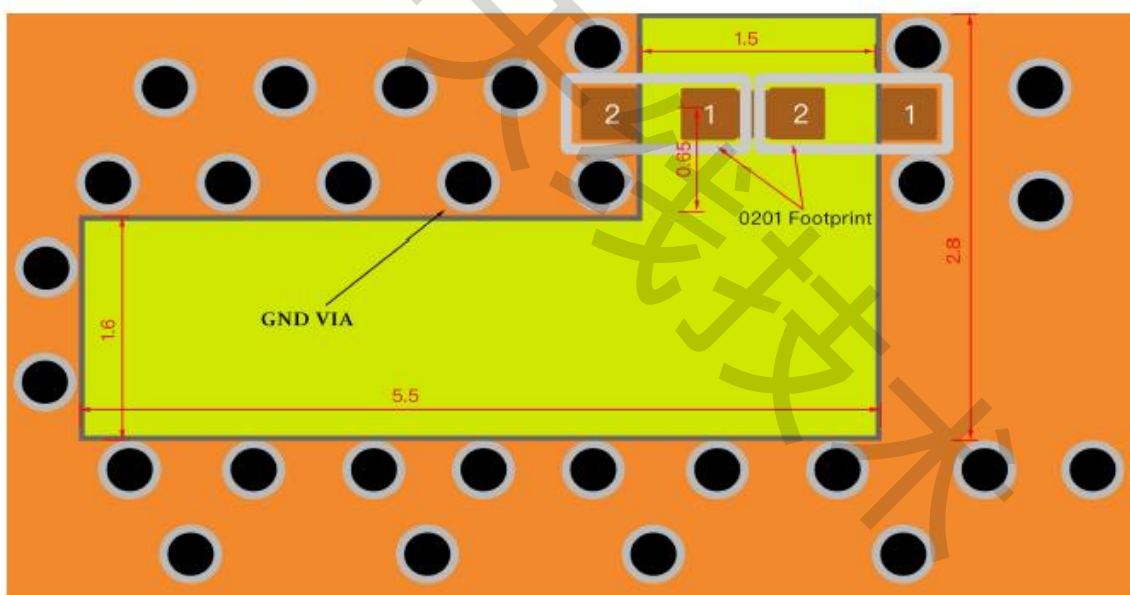
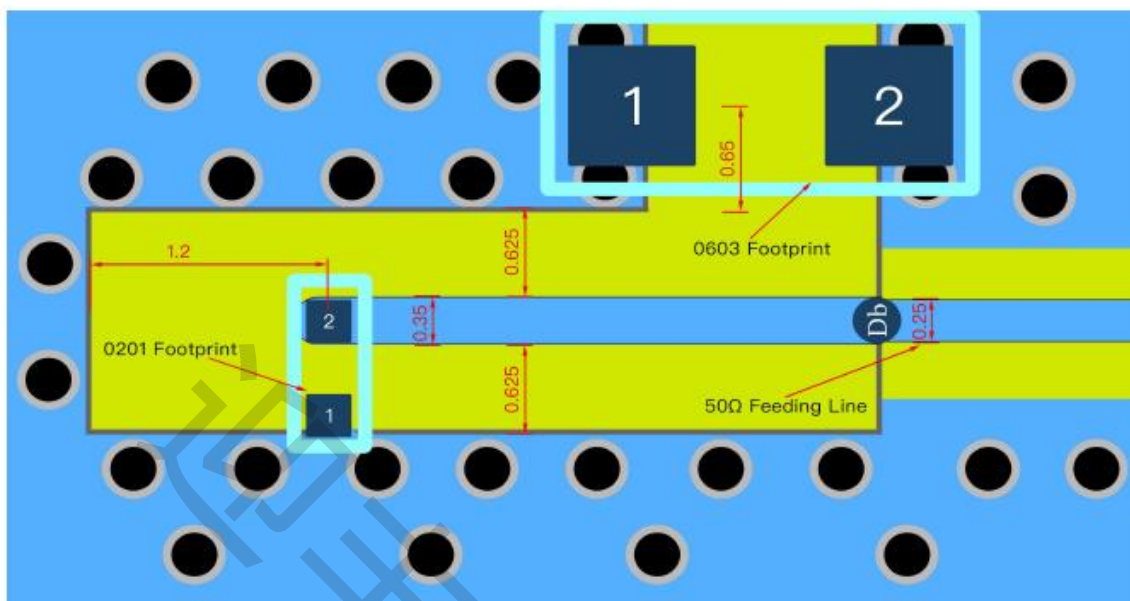

深圳市迎丰天线技术有限公司

SHEN ZHEN YINGFENG ANTENNA TECHNOLOGYCO.,LTD

Prepared by : JIEXI

Designed by : Jason

Checked by : Jason

Approved by : MR.FANG

TITLE : 1.6 x0.8x 0.8(mm) WiFi/Bluetooth Ceramic Chip
Antenna (YF1608) Engineering Specification

DOCUMENT
NO.

YF1608F1P2G45

REV.
C

原理图

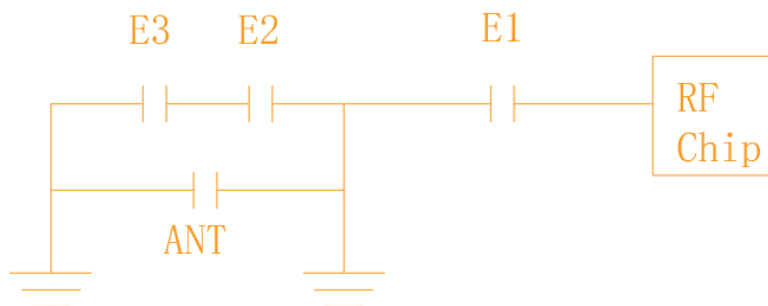

7. Radiation Pattern (80 x 40 mm² ground plane)

7-1. 3D Gain Pattern @ 2442 MHz

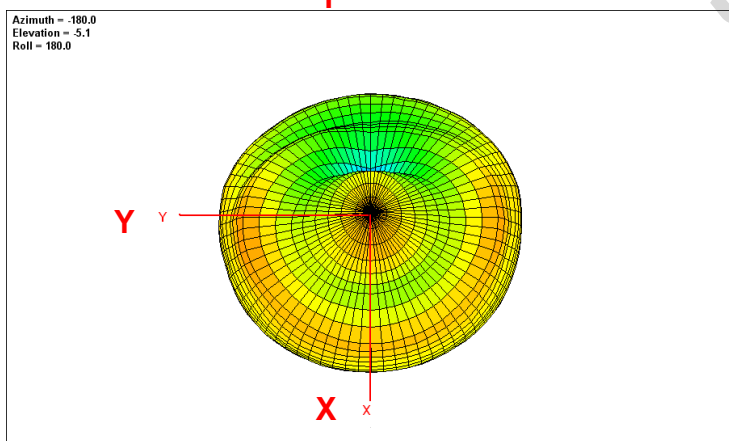
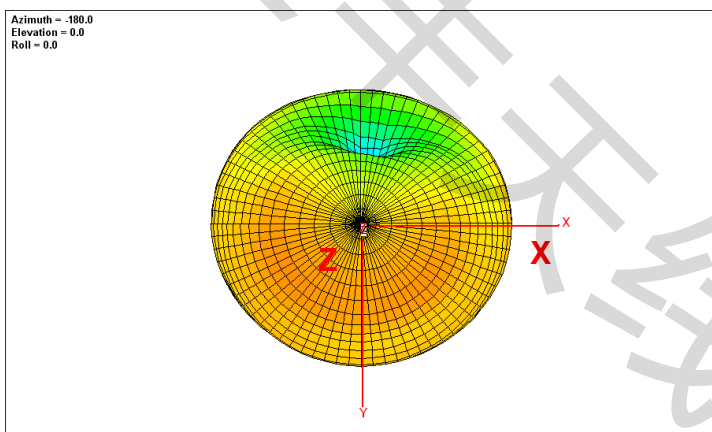

深圳市迎丰天线技术有限公司

SHEN ZHEN YINGFENG ANTENNA TECHNOLOGYCO.,LTD

Prepared by : JIEXI

Designed by : Jason

Checked by : Jason

Approved by : MR.FANG

TITLE : 1.6 x0.8x 0.8(mm) WiFi/Bluetooth Ceramic Chip
Antenna (YF1608) Engineering Specification

DOCUMENT
NO.

YF1608F1P2G45

REV.
C

Azimuth = 0.0
Elevation = 30.0
Roll = 180.0

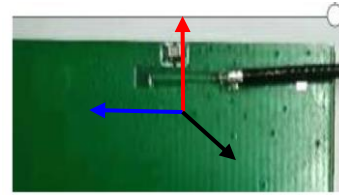
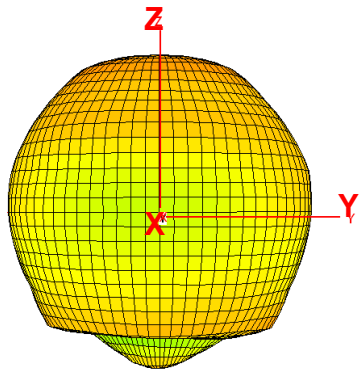

7-2. 3D Efficiency Table

Frequency(MHz)	2400	2410	2420	2430	2442	2450	2460	2470	2480	2490	2500
Efficiency (dB)	-1.4	-1.0	-0.9	-0.7	-0.7	-0.8	-0.9	-1.1	-1.2	-1.3	-1.4
Efficiency (%)	53.8	54.7	55.3	56.4	57.5	58.0	57.0	56.6	55.1	54.6	54.5
Gain (dBi)	2.1	2.2	2.3	2.4	2.5	2.5	2.4	1.8	1.7	1.6	1.4



深圳市迎丰天线技术有限公司

SHEN ZHEN YINGFENG ANTENNA TECHNOLOGYCO.,LTD

Prepared by : JIEXI

Designed by : Jason

Checked by : Jason

Approved by : MR.FANG

TITLE : 1.6 x0.8x 0.8(mm) WiFi/Bluetooth Ceramic Chip
Antenna (YF1608) Engineering Specification

DOCUMENT
NO.

YF1608F1P2G45

REV.
C

Temperature Cycle Test

10±1S Applied Force: 5N Duration: 10±1S
 Preheating conditions: up-category temperature, 1h
 Recovery time: 24±1h
 Initial Measurement
 Cycling Times: 5 times, 1 cycle, 4 steps:

阶段	温度 (°C)	时间 (分钟)
第1步	下限温度 (下限温度: 10~20)	30
第2步	常温 (+20)	2~3
第3步	上限温度 (上限温度: 125~135)	30
第4步	常温 (+20)	2~3

Resistance to Soldering Heat

Preheating 80 to 120°C; 10~30s. Solder Temperature: 235±5°C; Duration: 2±0.5s; Solder Temperature: 245±5°C
 Duration: 2±0.5s, Preheating 100 to 200°C; 10±2min
 Solder Temperature: 265±5°C; Duration: 10±1s
 Clean the capacitor with solvent and examine it with a 10X(min.) microscope.
 Recovery Time: 24±2h
 Recovery condition: Room temperature

Resistance to Flexure of Substrate

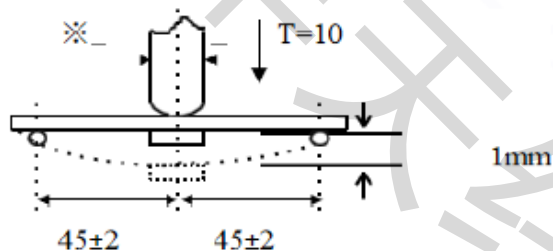

Test Board: Al₂O₃ or PCB Warp: 1mm Speed: 0.5mm/sec.
 Unit: mm

The measurement should be made with the board in the bending position.



深圳市迎丰天线技术有限公司

SHEN ZHEN YINGFENG ANTENNA TECHNOLOGY CO., LTD

Prepared by : JIEXI

Designed by : Jason

Checked by : Jason

Approved by : MR.FANG

TITLE : 1.6 x0.8x 0.8(mm) WiFi/Bluetooth Ceramic Chip
 Antenna (YF1608) Engineering Specification

DOCUMENT
 NO.

YF1608F1P2G45

REV.
 C

Dependability Test

Test Temperature	25°C ± 3°C
Operating Temperature	-25°C~+85°C
Temperature	5~40°C
Relative Humidity	20~70%

Moisture Proof

Temperature: 40 ± 2°C Humidity: 90~95%RH
 Duration: 500h
 Recovery conditions: Room temperature Recovery Time: 24h (Class1) or 48h (Class2)

Solderability

At least 95% of the terminal electrode is covered by new solder.
 Preheating conditions: 80 to 120°C; 10~30s
 Solder Temperature: 235 ± 5°C Duration 2 ± 0.5s, Solder Temperature: 245 ± 5°C Duration: 2 ± 0.5s

Optimum Solder Amount for Reflow Soldering

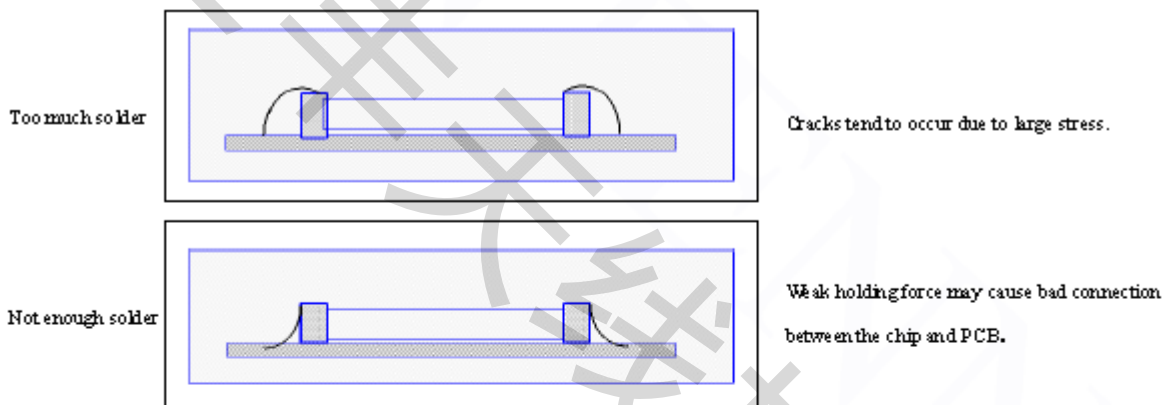

Recommended Soldering Amounts

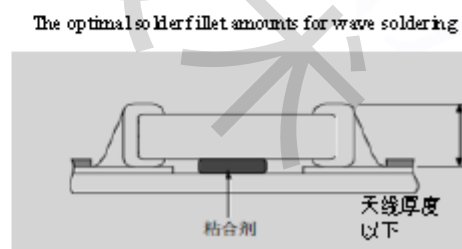
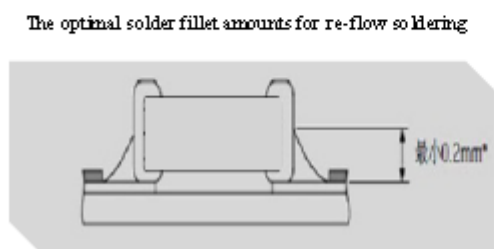

深圳市迎丰天线技术有限公司

SHEN ZHEN YINGFENG ANTENNA TECHNOLOGY CO.,LTD

Prepared by : JIEXI Designed by : Jason Checked by : Jason Approved by : MR.FANG

TITLE : 1.6 x0.8x 0.8(mm) WiFi/Bluetooth Ceramic Chip Antenna (YF1608) Engineering Specification	DOCUMENT NO.	YF1608F1P2G45	REV.
			C

Dimensions of paper taping

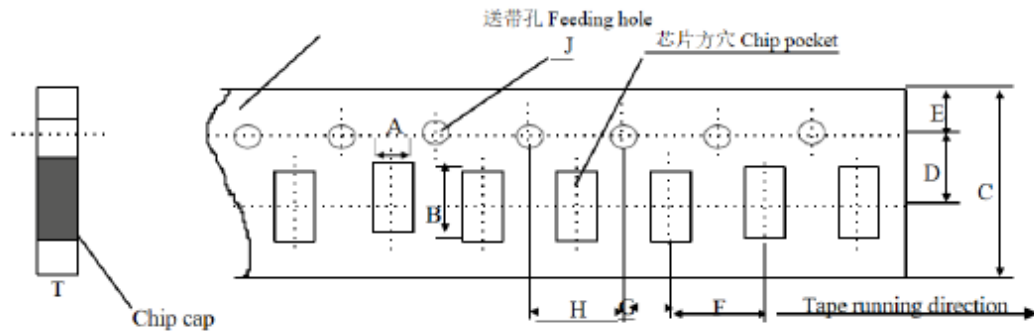

Unit: mm

代号Code 纸带规格 papersize	A	B	C	D*	E	F	G*	H	J	T
尺寸	1.10	1.90	8.00	3.50	1.75	4.00	2.00	4.00	1.50	1.10
	±0.10	±0.10	±0.10	±0.05	±0.10	±0.10	±0.10	±0.10	±0.10	Max

Reel (4000 pcs/Reel)

EMBOSED TAPING

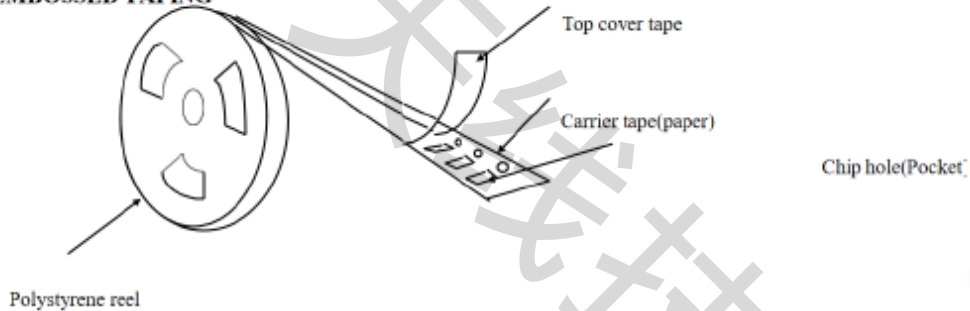

Storage Period

The guaranteed period for solderability is 6 months (Under deliver package condition).
Temperature: 5~40°C /Relative Humidity: 20~70%



深圳市迎丰天线技术有限公司

SHEN ZHEN YINGFENG ANTENNA TECHNOLOGYCO.,LTD

Prepared by : JIEXI

Designed by : Jason

Checked by : Jason

Approved by : MR.FANG

TITLE : 1.6 x0.8x 0.8(mm) WiFi/Bluetooth Ceramic Chip
Antenna (YF1608) Engineering Specification

DOCUMENT
NO.

YF1608F1P2G45

REV.
C