

TEST REPORT

Applicant Name : PO FUNG ELECTRONIC (HK) INTERNATONAL GROUP COMPANY LIMITED
 Address : Room 1508, 15/F, Office Tower II, Grand Plaza, 625 Nathan Road, Kowloon, Hong Kong
 Report Number : XMTN1220727-34198E-RF-00A
 FCC ID: 2AJGM-MP23

Test Standard (s)
 FCC PART 95

Sample Description

Product Type: FRS TWO WAY RADIO
 Model No.: MP23, BF-T23, CT23-GF1, TH23
 Trade Mark: BAOFENG, POFUNG
 Date Received: 2022-07-27
 Date of Test: 2022-08-12 to 2022-08-23
 Report Date: 2022-08-24

Test Result:	Pass*
--------------	-------

* In the configuration tested, the EUT complied with the standards above.

Prepared and Checked By:

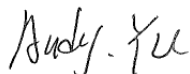

Andy Yu
 EMC Engineer

Approved By:

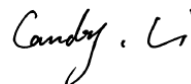

Candy Li
 EMC Engineer

Note: This report may contain data that are not covered by the A2LA accreditation and are marked with an asterisk "★".
 Shenzhen Accurate Technology Co., Ltd. is not responsible for the authenticity of any test data provided by the applicant. Data included from the applicant that may affect test results are marked with an asterisk ". Customer model name, addresses, names, trademarks etc. are not considered data.
 This report cannot be reproduced except in full, without prior written approval of the Company. Unless otherwise stated the results shown in this test report refer only to the sample(s) tested. This report is valid only with a valid digital signature. The digital signature may be available only under the Adobe software above version 7.0.

Shenzhen Accurate Technology Co., Ltd.

1/F., Building A, Changyuan New Material Port, Science & Industry Park, Nanshan District, Shenzhen, Guangdong, P.R. China
 Tel: +86 755-26503290 Fax: +86 755-26503396 Web: www.atc-lab.com

TABLE OF CONTENTS

GENERAL INFORMATION.....	3
PRODUCT DESCRIPTION FOR EQUIPMENT UNDER TEST (EUT)	3
OBJECTIVE	3
TEST METHODOLOGY	3
MEASUREMENT UNCERTAINTY	4
TEST FACILITY	4
SYSTEM TEST CONFIGURATION.....	5
DESCRIPTION OF TEST CONFIGURATION	5
DESCRIPTION OF CHANNEL LIST	5
EQUIPMENT MODIFICATIONS	5
SUPPORT EQUIPMENT LIST AND DETAILS	5
BLOCK DIAGRAM OF TEST SETUP	6
SUMMARY OF TEST RESULTS.....	7
TEST EQUIPMENT LIST	8
FCC §1.1307(b) & §2.1093 - RF EXPOSURE.....	9
APPLICABLE STANDARD	9
FCC §95.587(b)(1)(2)(3) – ANTENNA REQUIREMENT	10
FCC §2.1046 & §95.567 - RF OUTPUT POWER.....	11
APPLICABLE STANDARD	11
TEST PROCEDURE	11
TEST DATA	11
FCC §2.1047 & §95.575 - MODULATION CHARACTERISTIC.....	12
APPLICABLE STANDARD	12
TEST PROCEDURE	12
TEST DATA	12
FCC §2.1049 & §95.573&§95.579- AUTHOURIZED BANDWIDTH AND EMISSION MASK.....	23
APPLICABLE STANDARD	23
TEST PROCEDURE	23
TEST DATA	24
FCC §2.1053 & §95.579 - RADIATED SPURIOUS EMISSION	27
APPLICABLE STANDARD	27
TEST PROCEDURE	27
TEST DATA	27
FCC§2.1055 (d) & §95.565 - FREQUENCY STABILITY	29
APPLICABLE STANDARD	29
TEST PROCEDURE	29
TEST DATA	30

GENERAL INFORMATION

Product Description for Equipment Under Test (EUT)

Product	FRS TWO WAY RADIO
Tested Model	MP23
Multiple Model	BF-T23, CT23-GF1, TH23
Model Differences	Please refer to the DoS letter
Frequency Range	462.5500 MHz -462.7250MHz 467.5625 MHz -467.7125MHz
The Maximum Output Power (ERP)	462.6375 MHz: 31.80dBm 467.6375 MHz: 22.45dBm
Modulation Technique	FM
Antenna Type	Integral Antenna
Antenna Specification*	Antenna: 1.5dBi
Voltage Range	DC 3.7V from battery or DC 5V from adapter
Sample serial number	XMTN1220727-34198E-RF-S1 (RF Radiated Test) XMTN1220727-34198E-RF-S2 (RF Conduced Test) (Assigned by ATC, Shenzhen)
Sample/EUT Status	Good condition
Normal/Extreme Condition	L.V.: Low Voltage: 3.5V _{DC} N.V.: Nominal Voltage: 3.7V _{DC} H.V.: High Voltage: 4.2V _{DC} L.T.: Low Temperature -20°C H.T.: High Temperature +50°C

Objective

This test report is in accordance with Part 2 and Part 95, Subpart A & Subpart B of the Federal Communication Commissions rules.

Test Methodology

All tests and measurements indicated in this document were performed in accordance with Part 95 Subpart A, Subpart E of the Federal Communication Commissions rules with TIA-603-E 2016, Land Mobile FM or PM-Communications Equipment-Measurement and Performance Standards, and ANSI C63.26-2015: American National Standard for Compliance Testing of Transmitters Used in Licensed Radio Services.

All emissions measurement was performed at Shenzhen Accurate Technology Co., Ltd. The radiated testing was performed at an antenna-to-EUT distance of 3 meters.

Measurement Uncertainty

Parameter		Uncertainty
Occupied Channel Bandwidth		5%
RF Frequency		0.082×10^{-7}
RF output power, conducted		0.73dB
Unwanted Emission, conducted		1.6dB
AC Power Lines Conducted Emissions		2.72dB
Audio Frequency Response		0.1dB
Low Pass Filter Response		1.2dB
Modulation Limiting		1%
Emissions, Radiated	9kHz - 30MHz	2.66dB
	30MHz - 1GHz	4.28dB
	1GHz - 18GHz	4.98dB
	18GHz - 26.5GHz	5.06dB
	26.5GHz - 40GHz	4.72dB
Temperature		1°C
Humidity		6%
Supply voltages		0.4%

Note: The extended uncertainty given in this report is obtained by combining the standard uncertainty times the coverage factor K with the 95% confidence interval. Otherwise required by the applicant or Product Regulations, Decision Rule in this report did not consider the uncertainty.

Test Facility

The test site used by Shenzhen Accurate Technology Co., Ltd. to collect test data is located on the 1/F., Building A, Changyuan New Material Port, Science & Industry Park, Nanshan District, Shenzhen, Guangdong, P.R. China.

The test site has been approved by the FCC under the KDB 974614 D01 and is listed in the FCC Public Access Link (PAL) database, FCC Registration No.: 708358, the FCC Designation No.: CN1189.

Accredited by American Association for Laboratory Accreditation (A2LA). The Certificate Number is 4297.01

The lab has been recognized by Innovation, Science and Economic Development Canada to test to Canadian radio equipment requirements, the CAB identifier: CN0016. The Registration Number is 5077A.

SYSTEM TEST CONFIGURATION

Description of Test Configuration

The system was configured for testing in a typical fashion (as normally used by a typical user).

Description of Channel List

Channel No.	Channel Frequency (MHz)	Channel No.	Channel Frequency (MHz)
1	462.5625	12	467.6625
2	462.5875	13	467.6875
3	462.6125	14	467.7125
4	462.6375	15	462.5500
5	462.6625	16	462.5750
6	462.6875	17	462.6000
7	462.7125	18	462.6250
8	467.5625	19	462.6500
9	467.5875	20	462.6750
10	467.6125	21	462.7000
11	467.6375	22	462.7250

Test channel list as below, EUT was tested with channel 4, and 11.

Equipment Modifications

No modification was made to the EUT tested.

Support Equipment List and Details

Manufacturer	Description	Model	Serial Number
/	/	/	/

External I/O Cable

Cable Description	Length (m)	From Port	To Port
/	/	/	/

Block Diagram of Test Setup

For Spurious emission test:

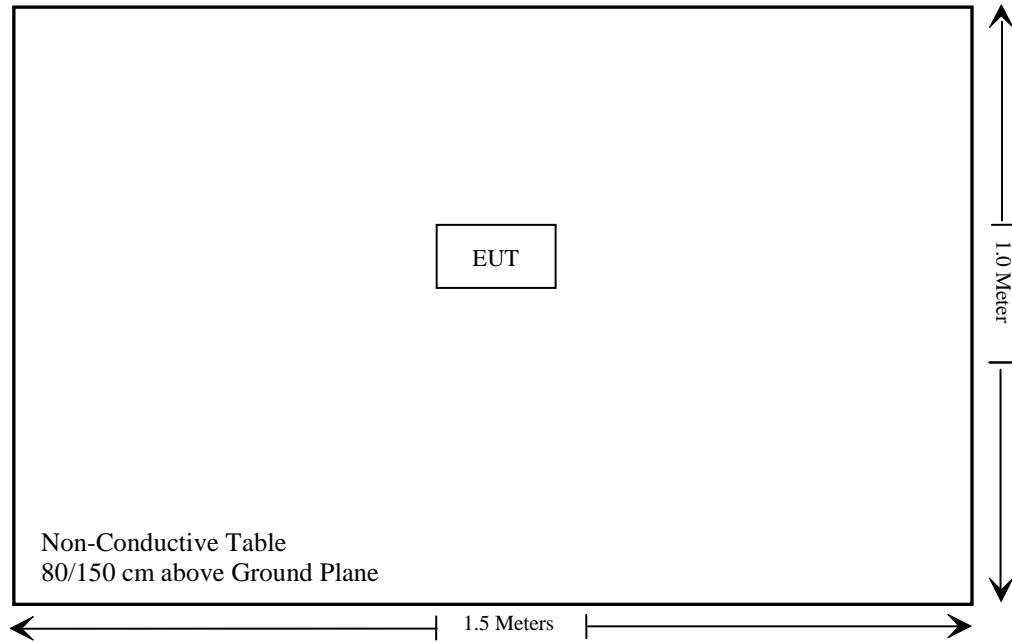

SUMMARY OF TEST RESULTS

FCC Rules	Description of Test	Results
§2.1093	RF Exposure	Compliant
§95.587(b)(1)(2)(3)	Antenna Requirement	Compliant
§2.1046, §95.567	RF Output Power	Compliant
§2.1047, §95.575	Modulation Characteristic	Compliant
§2.1049, §95.573, §95.579	Authorized Bandwidth & Emission Mask	Compliant
§2.1053, §95.579	Radiated Spurious Emission	Compliant
§2.1055(d), §95.565	Frequency Stability	Compliant

TEST EQUIPMENT LIST

Manufacturer	Description	Model	Serial Number	Calibration Date	Calibration Due Date
Radiated Emissions Test					
Rohde & Schwarz	Test Receiver	ESR	102725	2021/12/13	2022/12/12
Rohde & Schwarz	Spectrum Analyzer	FSV40	101949	2021/12/13	2022/12/12
A.H. Systems, inc.	Preamplifier	PAM-0118P	135	2021/11/09	2022/11/08
SONOMA INSTRUMENT	Amplifier	310 N	186131	2021/11/09	2022/11/08
Schwarzbeck	Bilog Antenna	VULB9163	9163-323	2021/07/06	2024/07/05
Schwarzbeck	Bilog Antenna	VULB9163	9163-194	2020/01/05	2023/01/04
Schwarzbeck	Horn Antenna	BBHA9120D	9120D-1067	2020/01/05	2023/01/04
Schwarzbeck	Horn Antenna	BBHA9120D	9120D-655	2020/01/05	2023/01/04
Unknown	RF Coaxial Cable	No.10	N050	2021/12/14	2022/12/13
Unknown	RF Coaxial Cable	No.11	N1000	2021/12/14	2022/12/13
Unknown	RF Coaxial Cable	No.12	N040	2021/12/14	2022/12/13
Unknown	RF Coaxial Cable	No.13	N300	2021/12/14	2022/12/13
Unknown	RF Coaxial Cable	No.14	N800	2021/12/14	2022/12/13
Unknown	RF Coaxial Cable	No.16	N200	2021/12/14	2022/12/13
Agilent	Signal Generator	N5183A	MY51040755	2021/12/13	2022/12/12
Mini-Circuits	High Pass Filter	NHP-600+	15542	2021/12/14	2022/12/13
Radiated Emission Test Software: e3 19821b(V9)					
RF Conducted Test					
Rohde&Schwarz	Spectrum Analyzer	FSV-40	101948	2021/12/13	2022/12/12
Aeroflex/Weinschel	30dB Attenuator (Input 250W/Output 50W)	58-30-33	PS467	2021/12/14	2022/12/13
HP Agilent	RF Communication Test Set	8920B	3325U00859	2021/12/14	2022/12/13
Mini-Circuits	Power Splitter	DC-18000MHz	SF10944151S	2021/12/14	2022/12/13
Gongwen	Temp. & Humid. Chamber	HSD-500	109	2021/10/14	2022/10/13
UNI-T	DC Power Supply	UTP8305B	10584	NCR	NCR
Fluke	Desktop Multi Meter	45	7664009	2021/12/14	2022/12/13
Unknown	RF Coaxial Cable	No.31	RF-01	Each time	
Unknown	RF Coaxial Cable	No.32	RF-02	Each time	

* **Statement of Traceability:** Shenzhen Accurate Technology Co., Ltd. attests that all calibrations have been performed in accordance to requirements that traceable to National Primary Standards and International System of Units (SI).

FCC §1.1307(b) & §2.1093 - RF EXPOSURE

Applicable Standard

According to FCC §1.1307(b) and §2.1093, portable device operates Part 95 should be subjected to routine environmental evaluation for RF exposure prior or equipment authorization or use.

Result: Compliant.

Please refer to SAR Report Number: CR22070068-20A.

FCC §95.587(b)(1)(2)(3) – ANTENNA REQUIREMENT

Applicable Standard

According to FCC § 95.587, (b) Antenna. The antenna of each FRS transmitter type must meet the following requirements.

- (1) The antenna must be a non-removable integral part of the FRS transmitter type.
- (2) The gain of the antenna must not exceed that of a half-wave dipole antenna.
- (3) The antenna must be designed such that the electric field of the emitted waves is vertically polarized when the unit is operated in the normal orientation.

Antenna Description

The EUT has an integral vertically polarized antenna arrangement and the antenna gain is 1.5dBi, fulfill the requirement of this section. Please refer to the EUT photos.

Result: Compliant.

FCC §2.1046 & §95.567 - RF OUTPUT POWER

Applicable Standard

Per FCC §2.1046, and §95.567, Each FRS transmitter type must be designed such that the effective radiated power (ERP) on channels 8 through 14 does not exceed 0.5 Watts and the ERP on channels 1 through 7 and 15 through 22 does not exceed 2.0 Watts.

Test Procedure

The transmitter was placed on a wooden turntable, and it was transmitting into a non-radiating load, which was also placed on the turntable.

The measurement antenna was placed at a distance of 3 meters from the EUT. During the tests, the antenna height and polarization as well as EUT azimuth were varied in order to identify the maximum level of emissions from the EUT. The test was performed by placing the EUT on 3-orthogonal axis.

Remove the EUT and replace it with substitution antenna. A signal generator was connected to the substitution antenna by a non-radiating cable. The absolute levels of the emissions were measured by the substitution.

Test Data

Environmental Conditions

Temperature:	25°C
Relative Humidity:	60 %
ATM Pressure:	102.0 kPa

The testing was performed by Level Li on 2022-08-12.

Test Mode: Transmitting

Test Result: Compliant.

Frequency (MHz)	Receiver		Turntable Angle Degree	Rx Antenna		Substituted Factor (dB)	Absolute Level (dBm)	Limit (dBm)	Margin (dB)
	Reading (dBm)	PK/AV		Height (m)	Polar (H/V)				
Frequency:462.6375MHz									
462.6375	13.95	PK	129	1.5	H	9.14	23.09	33	-9.91
462.6375	26.78	PK	85	1.8	V	5.02	31.8	33	-1.2
Frequency:467.6375MHz									
467.6375	9.22	PK	143	1.5	H	8.26	17.48	27	-9.52
467.6375	17.04	PK	228	1.1	V	5.41	22.45	27	-4.55

Note:

Absolute Level = Reading Level + Substituted Factor

Substituted Factor contains: SG Level - Cable loss+ Antenna Gain

Margin = Absolute Level - Limit

FCC §2.1047 & §95.575 - MODULATION CHARACTERISTIC

Applicable Standard

Per FCC §2.1047 and §95.575: Each FRS transmitter type must be designed such that the peak frequency deviation does not exceed 2.5 kHz, and the highest audio frequency contributing substantially to modulation must not exceed 3.125 kHz.

Test Procedure

Test Method: TIA/EIA-603-E

Setup Block Diagram for Modulation type:

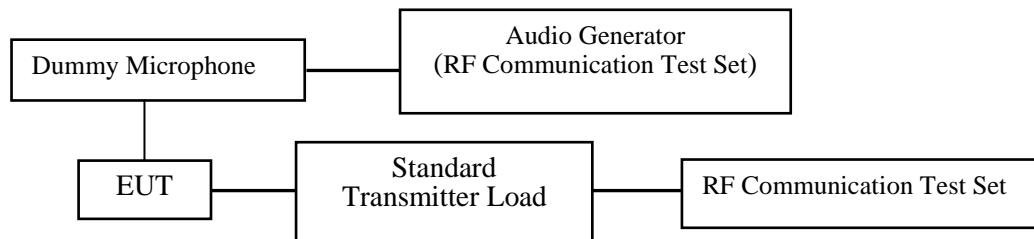

Setup Block Diagram for Audio Frequency filter:

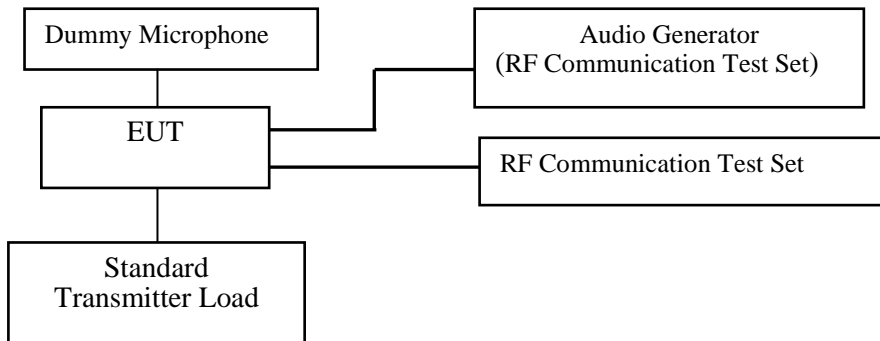

Test Data

Environmental Conditions

Temperature:	25°C
Relative Humidity:	53 %
ATM Pressure:	101.0 kPa

The testing was performed by Jesse Chen from 2022-08-17 to 2022-08-20.

Please refer to the following tables and plots.

Test Mode: Transmitting

MODULATION LIMITING

Carrier Frequency: 462.6375MHz

Audio Frequency (Hz)	Instantaneous		Steady-state		FCC Limit [kHz]
	DEVIATION (@+20dB) [kHz]	DEVIATION (@-20dB) [kHz]	DEVIATION (@+20dB) [kHz]	DEVIATION (@-20dB) [kHz]	
300	0.698	0.076	0.689	0.070	2.500
400	1.175	0.091	1.170	0.080	2.500
500	1.398	0.083	1.393	0.077	2.500
600	1.652	0.095	1.643	0.087	2.500
700	1.865	0.095	1.856	0.090	2.500
800	1.921	0.094	1.915	0.088	2.500
900	1.978	0.110	1.973	0.101	2.500
1000	2.098	0.114	2.092	0.104	2.500
1200	2.284	0.115	2.278	0.110	2.500
1400	2.270	0.133	2.259	0.123	2.500
1600	2.256	0.136	2.251	0.125	2.500
1800	2.267	0.147	2.258	0.136	2.500
2000	2.292	0.152	2.282	0.144	2.500
2100	2.301	0.158	2.293	0.151	2.500
2200	2.305	0.169	2.297	0.164	2.500
2300	2.307	0.179	2.302	0.172	2.500
2400	2.304	0.175	2.298	0.170	2.500
2500	2.312	0.178	2.304	0.167	2.500
2600	2.320	0.190	2.312	0.184	2.500
2700	2.322	0.184	2.315	0.173	2.500
2800	2.299	0.197	2.293	0.190	2.500
2900	2.302	0.201	2.297	0.194	2.500
3000	2.288	0.200	2.278	0.193	2.500

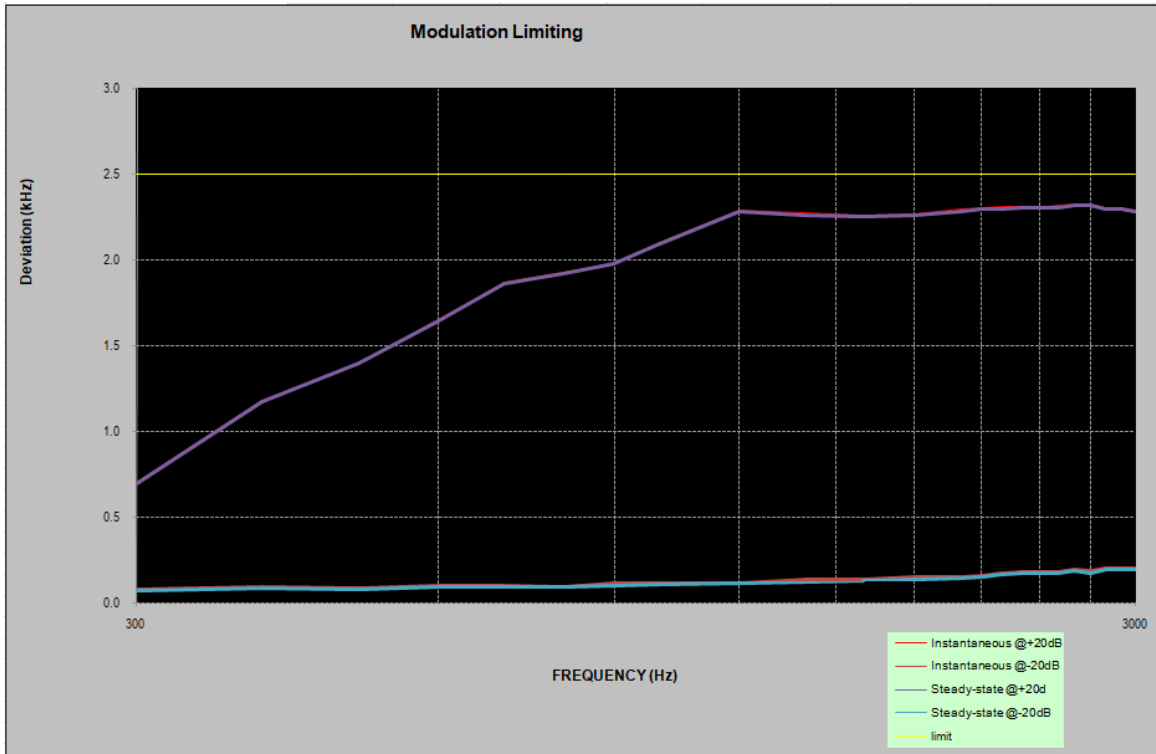

MODULATION LIMITING

Carrier Frequency: 467.6375MHz

Audio Frequency (Hz)	Instantaneous		Steady-state		FCC Limit [kHz]
	DEVIATION (@+20dB) [kHz]	DEVIATION (@-20dB) [kHz]	DEVIATION (@+20dB) [kHz]	DEVIATION (@-20dB) [kHz]	
300	0.701	0.053	0.694	0.044	2.500
400	1.115	0.061	1.107	0.052	2.500
500	1.409	0.069	1.399	0.062	2.500
600	1.665	0.074	1.656	0.065	2.500
700	1.872	0.085	1.863	0.080	2.500
800	1.912	0.077	1.907	0.071	2.500
900	1.973	0.082	1.966	0.071	2.500
1000	2.099	0.086	2.093	0.079	2.500
1200	2.288	0.099	2.280	0.088	2.500
1400	2.253	0.106	2.252	0.099	2.500
1600	2.241	0.121	2.230	0.116	2.500
1800	2.266	0.128	2.259	0.119	2.500
2000	2.300	0.135	2.294	0.124	2.500
2100	2.306	0.139	2.299	0.128	2.500
2200	2.317	0.145	2.311	0.138	2.500
2300	2.324	0.151	2.316	0.146	2.500
2400	2.311	0.153	2.301	0.144	2.500
2500	2.304	0.165	2.298	0.156	2.500
2600	2.302	0.164	2.294	0.154	2.500
2700	2.295	0.176	2.284	0.167	2.500
2800	2.278	0.173	2.268	0.167	2.500
2900	2.284	0.182	2.274	0.176	2.500
3000	2.259	0.179	2.250	0.168	2.500

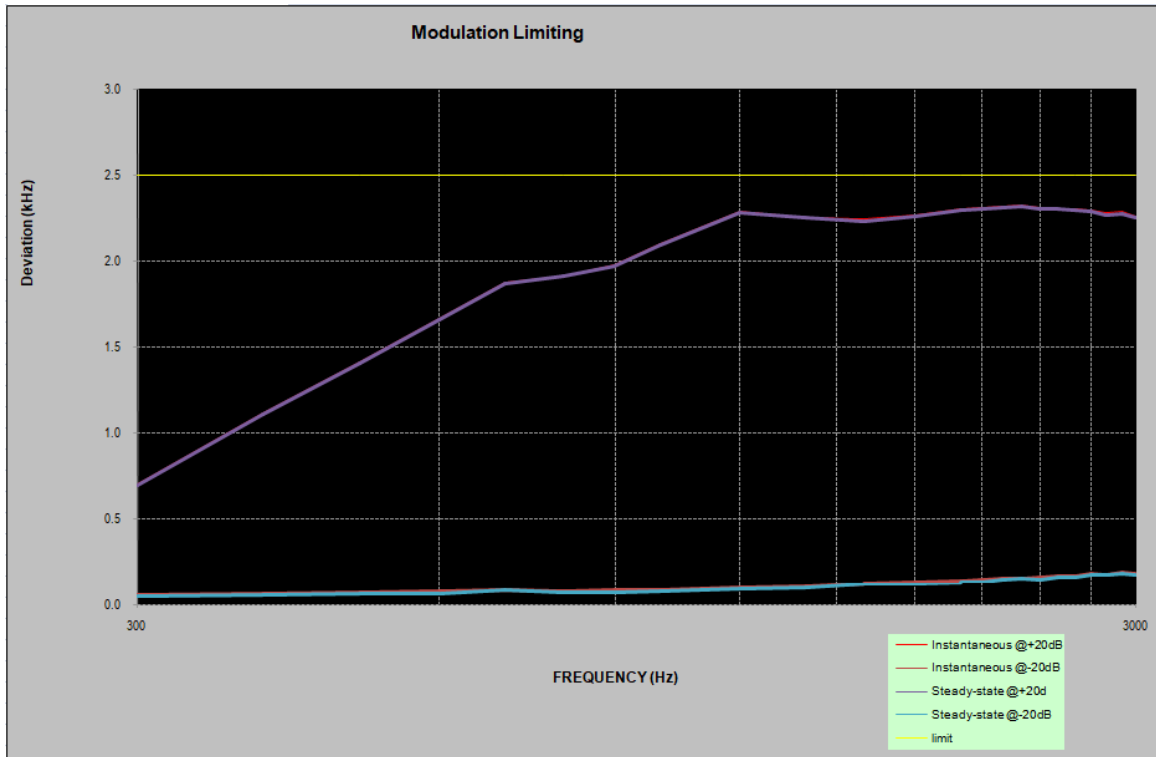

Audio Frequency Response

Carrier Frequency: 462.6375MHz

Audio Frequency (Hz)	Response Attenuation (dB)
300	-10.69
400	-7.49
500	-5.71
600	-3.77
700	-2.88
800	-1.70
900	-0.74
1000	0
1200	1.64
1400	3.02
1600	4.20
1800	5.06
2000	6.03
2100	6.44
2200	6.84
2300	7.29
2400	7.63
2500	7.92
2600	8.21
2700	8.53
2800	8.78
2900	9.04
3000	9.18

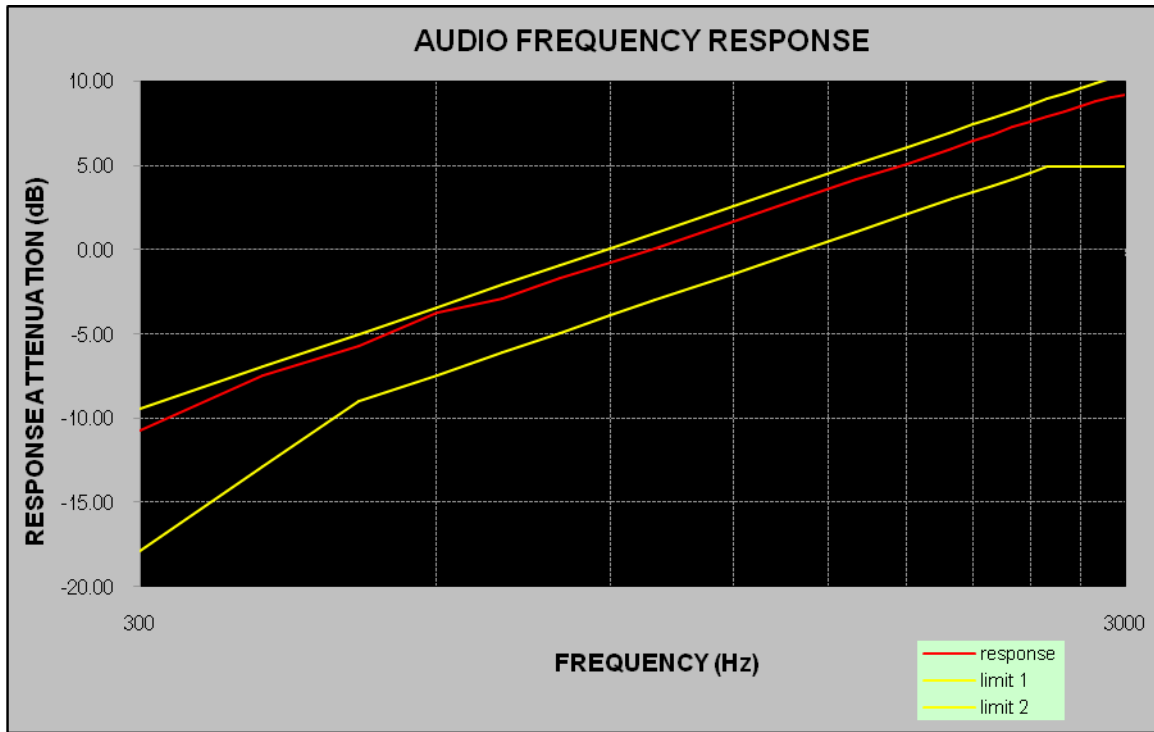

Carrier Frequency: 467.6375MHz

Audio Frequency (Hz)	Response Attenuation (dB)
300	-10.75
400	-7.26
500	-5.26
600	-3.69
700	-2.76
800	-1.70
900	-0.90
1000	0
1200	1.64
1400	2.87
1600	4.06
1800	5.21
2000	6.06
2100	6.45
2200	6.87
2300	7.24
2400	7.64
2500	8.00
2600	8.31
2700	8.56
2800	8.86
2900	9.02
3000	9.10

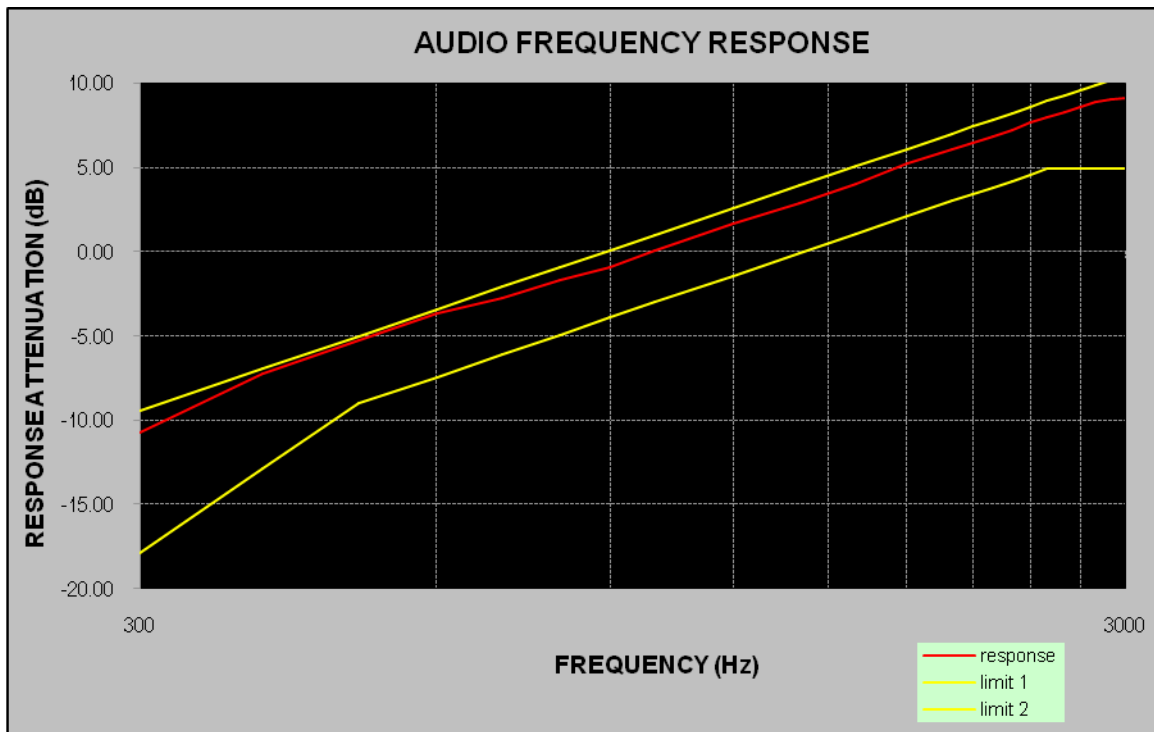

Audio frequency lows pass filter response

Carrier Frequency: 462.6375 MHz

Audio Frequency (kHz)	Response Attenuation (dB)	Limit (dB)
1.0	0.0	/
3.0	-13.6	0.0
4.0	-66.5	-12.5
5.0	-78.2	-22.2
6.0	-83.8	-30.1
7.0	-84.3	-36.8
8.0	-85.4	-42.6
9.0	-85.6	-47.7
10.0	-86.2	-52.3
15.0	-86.9	-69.9
20.0	-87.3	-82.4

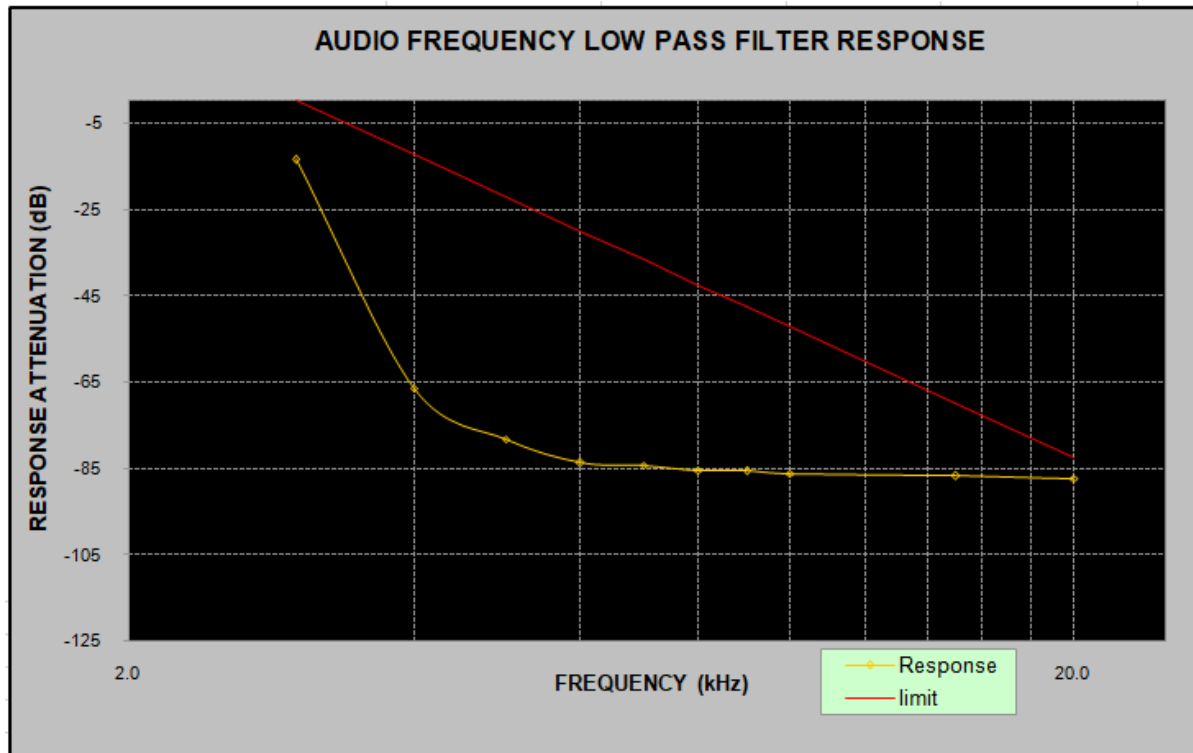

Audio frequency lows pass filter response

Carrier Frequency: 467.6375 MHz

Audio Frequency (kHz)	Response Attenuation (dB)	Limit (dB)
1.0	0.0	/
3.0	-13.9	0.0
4.0	-66.9	-12.5
5.0	-78.6	-22.2
6.0	-84.0	-30.1
7.0	-84.7	-36.8
8.0	-85.8	-42.6
9.0	-86.0	-47.7
10.0	-86.4	-52.3
15.0	-87.0	-69.9
20.0	-87.5	-82.4

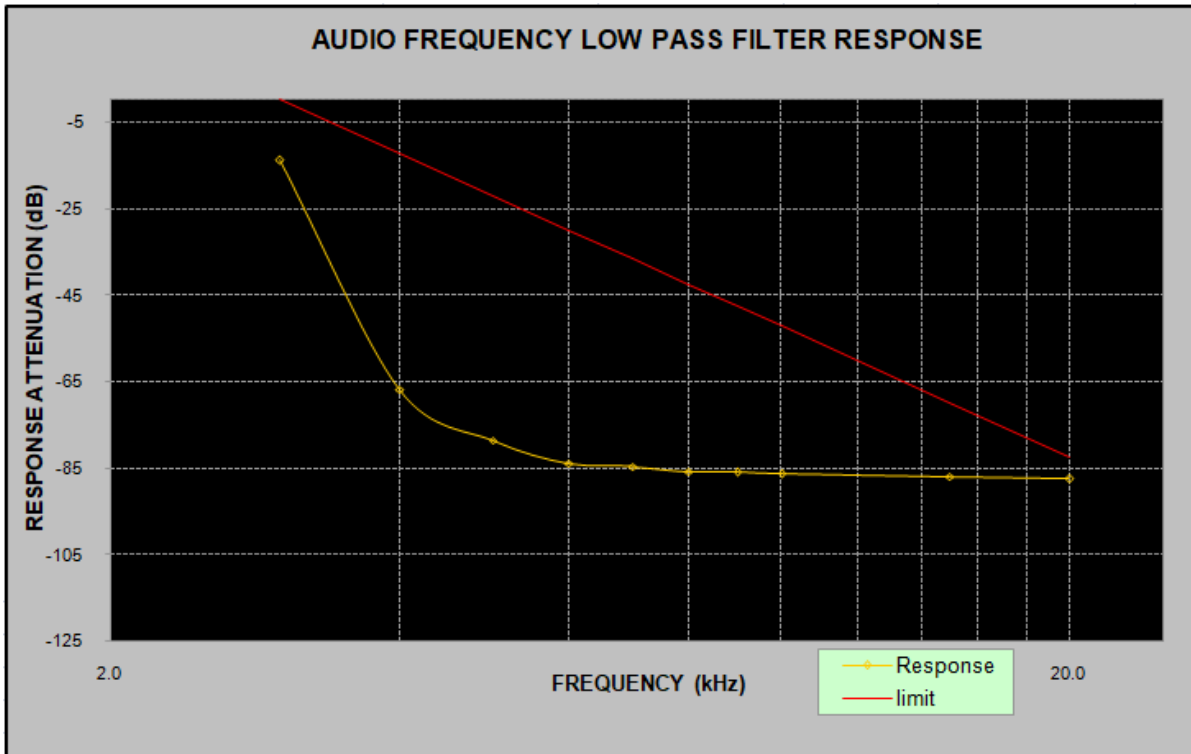

FCC §2.1049 & §95.573&§95.579- AUTHORIZED BANDWIDTH AND EMISSION MASK

Applicable Standard

According to §95.573

Each FRS transmitter type must be designed such that the occupied bandwidth does not exceed 12.5 kHz.

According to §95.579

Each FRS transmitter type must be designed to satisfy the applicable unwanted emissions limits in this paragraph.

(a) Attenuation requirements. The power of unwanted emissions must be attenuated below the carrier power output in Watts (P) by at least:

(1) 25 dB (decibels) in the frequency band 6.25 kHz to 12.5 kHz removed from the channel center frequency.

2) 35 dB in the frequency band 12.5 kHz to 31.25 kHz removed from the channel center frequency.

(3) $43 + 10 \log (P)$ dB in any frequency band removed from the channel center frequency by more than 31.25 kHz.

(b) Measurement bandwidths. The power of unwanted emissions in the frequency bands specified in paragraphs (a)(1) and (2) of this section is measured with a reference bandwidth of 300 Hz. The power of unwanted emissions in the frequency range specified in paragraph (a)(3) is measured with a reference bandwidth of at least 30 kHz.

(c) Measurement conditions. The requirements in this section apply to each FRS transmitter type both with and without the connection of permitted attachments, such as an external speaker, microphone and/or power cord.

Test Procedure

TIA-603-E 2016, section 2.2.11

Setup Block Diagram:

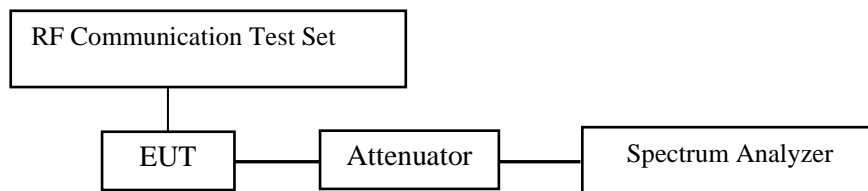

Test Data**Environmental Conditions**

Temperature:	25°C
Relative Humidity:	55 %
ATM Pressure:	101.0kPa

The testing was performed by Jesse Chen from 2022-08-17 to 2022-08-19.

Test Mode: Transmitting

Item	Frequency (MHz)	OBW (kHz)	20dB Bandwidth (kHz)	Limit (kHz)	Result
FM	462.6375	9.899	10.767	12.5	Pass
FM	467.6375	9.896	10.680	12.5	Pass

Emission Designator Per CFR 47 §2.201& §2.202&, $B_n = 2M + 2D$:

Emission Designator 11K0F3E In this case, the maximum modulating frequency is 3.0 kHz with a 2.5 kHz deviation. $BW = 2(M+D) = 2*(3.0 \text{ kHz} + 2.5 \text{ kHz}) = 11 \text{ kHz} \rightarrow 11K0$
 F3E portion of the designator represents an FM voice transmission Therefore, the entire designator for 12.5 kHz channel spacing FM mode is 11K0F3E.

OBW, 462.6357 MHz

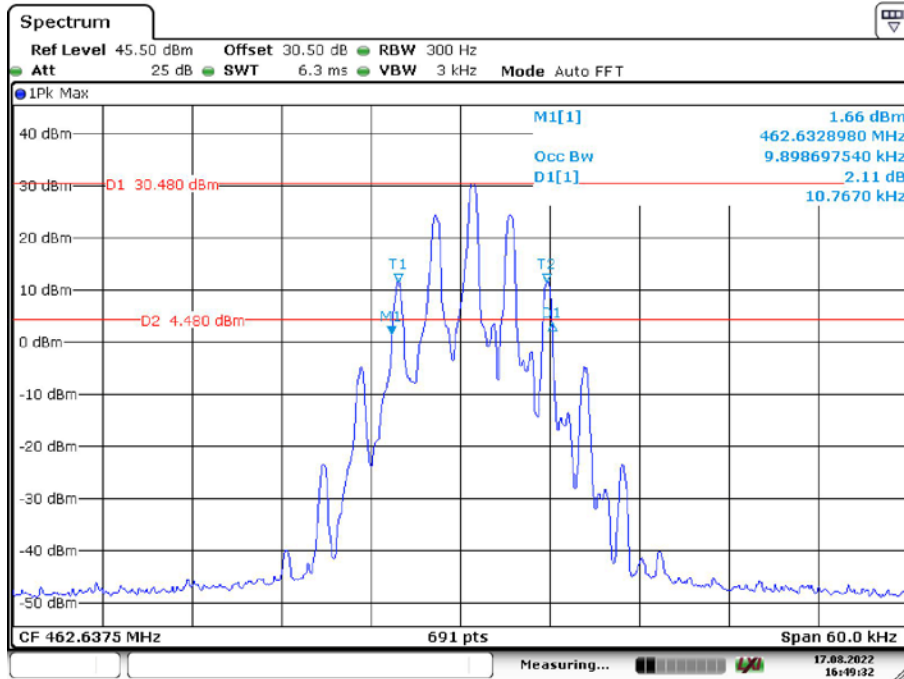

Date: 17.AUG.2022 16:49:32

Emission Mask, 462.6357 MHz

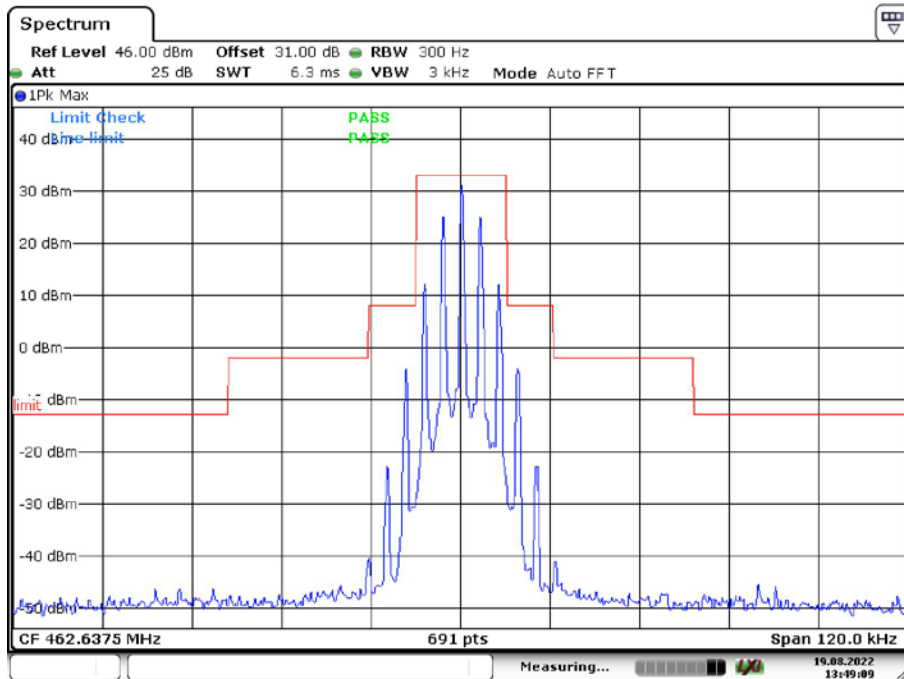

Date: 19.AUG.2022 13:49:09

OBW, 467.6375 MHz

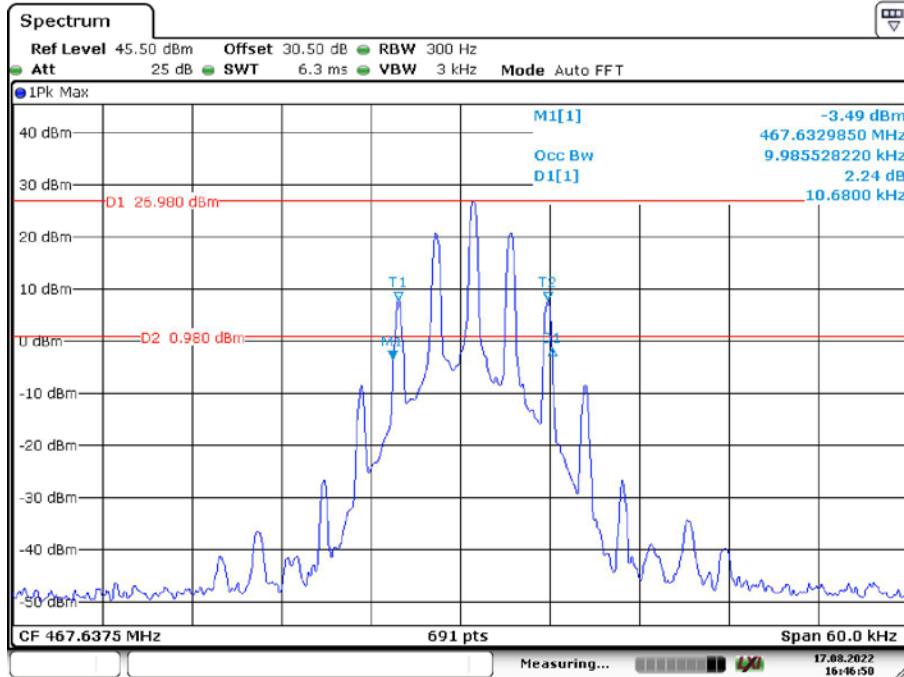

Date: 17.AUG.2022 16:46:50

Emission Mask, 467.6375 MHz

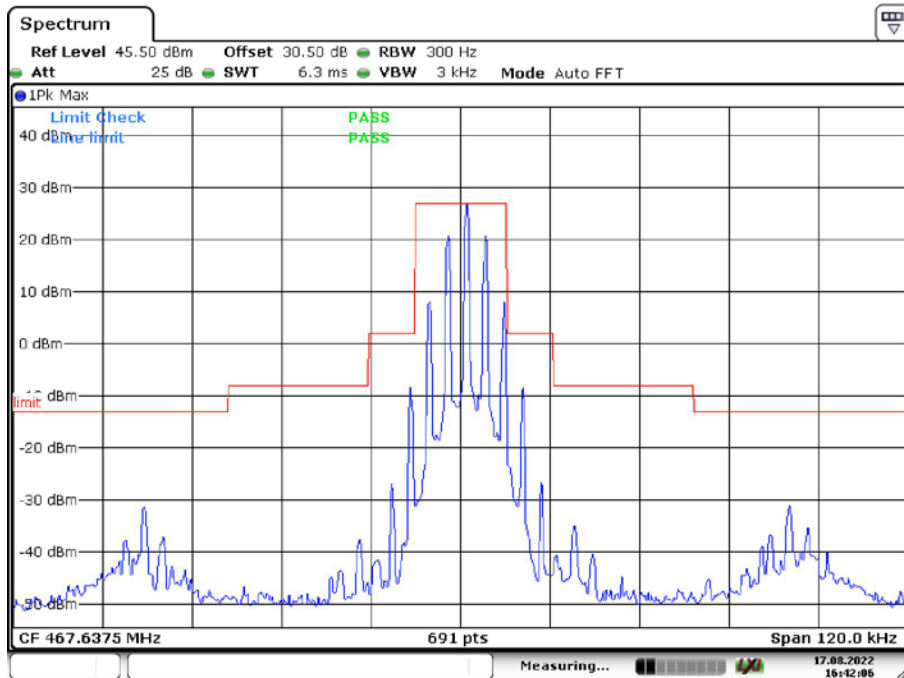

Date: 17.AUG.2022 16:42:06

FCC §2.1053 & §95.579 - RADIATED SPURIOUS EMISSION

Applicable Standard

FCC §2.1053 and §95.579. Each FRS transmitter type must be designed to satisfy the applicable unwanted emissions limits in this paragraph.

(a) *Attenuation requirements.* The power of unwanted emissions must be attenuated below the carrier power output in Watts (P) by at least:

- (1) 25 dB (decibels) in the frequency band 6.25 kHz to 12.5 kHz removed from the channel center frequency.
- (2) 35 dB in the frequency band 12.5 kHz to 31.25 kHz removed from the channel center frequency.
- (3) $43 + 10 \log (P)$ dB in any frequency band removed from the channel center frequency by more than 31.25 kHz.

(b) *Measurement bandwidths.* The power of unwanted emissions in the frequency bands specified in paragraphs (a)(1) and (2) of this section is measured with a reference bandwidth of 300 Hz. The power of unwanted emissions in the frequency range specified in paragraph (a)(3) is measured with a reference bandwidth of at least 30 kHz.

(c) *Measurement conditions.* The requirements in this section apply to each FRS transmitter type both with and without the connection of permitted attachments, such as an external speaker, microphone and/or power cord.

Test Procedure

The transmitter was placed on a wooden turntable.

The measurement antenna was placed at a distance of 3 meters from the EUT. During the tests, the antenna height and polarization as well as EUT azimuth were varied in order to identify the maximum level of emissions from the EUT. The test was performed by placing the EUT on 3-orthogonal axis.

The frequency range up to tenth harmonic of the fundamental frequency was investigated.

Remove the EUT and replace it with substitution antenna. A signal generator was connected to the substitution antenna by a non-radiating cable. The absolute levels of the spurious emissions were measured by the substitution.

Spurious emissions in dB = $10 \lg (\text{TXpwr in Watts}/0.001)$ -the absolute level

Spurious attenuation limit in dB = $43 + 10 \text{Log}_{10} (\text{power out in Watts})$

Test Data

Environmental Conditions

Temperature:	25°C
Relative Humidity:	60%
ATM Pressure:	102.0 kPa

The testing was performed by Level Li on 2022-08-12.

Test Mode: Transmitting (Scan with X axis, Y axis, Z axis, the worst case is Y axis)

30MHz - 5GHz:

Frequency (MHz)	Receiver Reading (dBm)	Turntable Degree	Rx Antenna		Substituted Factor (dB)	Absolute Level (dBm)	Limit (dBm)	Margin (dB)
			Height (m)	Polar (H/V)				
462.6375MHz								
1387.91	-31.08	83	1.20	H	6.02	-25.06	-13	-12.06
1387.91	-52.64	235	2.40	V	5.83	-46.81	-13	-33.81
1850.55	-50.41	126	2.00	H	4.39	-46.02	-13	-33.02
1850.55	-54.11	320	1.40	V	3.59	-50.52	-13	-37.52
2313.19	-50.66	253	2.30	H	7.23	-43.43	-13	-30.43
2313.19	-50.29	293	1.80	V	6.69	-43.60	-13	-30.60
2775.83	-50.50	313	2.30	H	6.70	-43.80	-13	-30.80
2775.83	-51.35	288	1.90	V	6.31	-45.04	-13	-32.04
3238.46	-55.79	68	1.10	H	7.00	-48.79	-13	-35.79
3238.46	-56.07	8	1.10	V	6.26	-49.81	-13	-36.81
3707.10	-52.28	139	1.10	H	8.12	-44.16	-13	-31.16
3707.10	-55.21	226	2.10	V	7.61	-47.60	-13	-34.60
4163.74	-58.47	93	1.50	H	9.37	-49.10	-13	-36.10
4163.74	-55.01	285	1.20	V	8.56	-46.45	-13	-33.45
4626.38	-60.51	358	1.80	H	10.51	-50.00	-13	-37.00
4626.38	-54.29	220	2.30	V	10.10	-44.19	-13	-31.19
925.275	-38.75	51	2.1	H	9.27	-29.48	-13	-16.48
925.275	-38.42	227	2.2	V	11.55	-26.87	-13	-13.87
467.6375MHz								
1402.91	-26.15	287	2.40	H	5.85	-20.30	-13	-7.30
1402.91	-40.36	52	2.30	V	5.8	-34.56	-13	-21.56
1870.55	-22.86	5	2.40	H	4.15	-18.71	-13	-5.71
1870.55	-29.51	333	1.50	V	3.35	-26.16	-13	-13.16
2338.19	-36.02	193	1.20	H	7.28	-28.74	-13	-15.74
2338.19	-30.71	82	2.30	V	6.49	-24.22	-13	-11.22
2805.83	-39.86	268	2.30	H	6.78	-33.08	-13	-20.08
2805.83	-37.95	103	1.50	V	6.67	-31.28	-13	-18.28
3273.462	-36.72	78	2.20	H	6.72	-30.00	-13	-17.00
3273.462	-42.83	95	2.10	V	5.91	-36.92	-13	-23.92
3741.1	-48.59	238	2.30	H	8.76	-39.83	-13	-26.83
3741.1	-46.91	126	1.60	V	7.93	-38.98	-13	-25.98
935.275	-39.25	66	1.2	H	9.22	-30.03	-13	-17.03
935.275	-39.55	76	1.5	V	11.65	-27.9	-13	-14.9

Note:

Absolute Level = Reading Level + Substituted Factor

Substituted Factor contains: SG Level - Cable loss+ Antenna Gain

Margin = Absolute Level - Limit

FCC§2.1055 (d) & §95.565 - FREQUENCY STABILITY

Applicable Standard

According to FCC §2.1055(a) (1), the frequency stability shall be measured with variation of ambient temperature from -20 °C to +50 °C, and according to FCC 2.1055(d) (2), the frequency stability shall be measured with reducing primary supply voltage to the battery operating end point which is specified by the manufacturer.

According to FCC §95.565, Each FRS transmitter type must be designed such that the carrier frequencies remain within ± 2.5 parts-per-million of the channel center frequencies specified in §95.563 during normal operating conditions.

Test Procedure

Frequency Stability vs. Temperature: The equipment under test was connected to an external DC power supply and the RF output was connected to a Frequency Counter via feed-through attenuators. The EUT was placed inside the temperature chamber. The DC leads and RF output cable exited the chamber through an opening made for the purpose.

After the temperature stabilized for approximately 20 minutes, the frequency output was recorded from the Frequency Counter.

Frequency Stability vs. Voltage (item 1 or item 2 will be chosen according to different condition) :

1) Vary primary supply voltage from 85 to 115 percent of the nominal value for other than hand carried battery equipment.

2) For hand carried, battery powered equipment, reduce primary supply voltage to the battery operating end point which shall be specified by the manufacturer.

The output frequency was recorded for each voltage.

Setup Block Diagram:

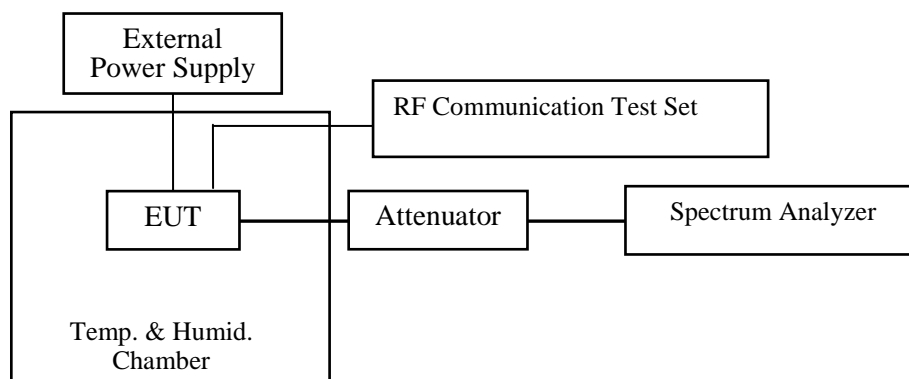

Test Data**Environmental Conditions**

Temperature:	24 °C
Relative Humidity:	54%
ATM Pressure:	101.0kPa

The testing was performed by Jesse Chen on 2022-08-23.

Test Mode: Transmitting

Reference Frequency: 462.6375 MHz, Limit: ±2.5ppm			
Environment Temperature (°C)	Voltage Supplied (V_{DC})	Measurement Frequency (MHz)	Frequency Error (ppm)
Frequency Stability Ver. Temperature			
50	3.7	462.637375	-0.27
40	3.7	462.637346	-0.33
30	3.7	462.637356	-0.31
20	3.7	462.637337	-0.35
10	3.7	462.637359	-0.30
0	3.7	462.637381	-0.26
-10	3.7	462.637390	-0.24
-20	3.7	462.637419	-0.17
Frequency Stability Ver. Input Voltage			
20	3.5	462.637409	-0.20
20	4.2	462.637353	-0.32

Reference Frequency: 467.6375 MHz, Limit: ± 2.5 ppm			
Environment Temperature (°C)	Voltage Supplied (V_{DC})	Measurement Frequency (MHz)	Frequency Error (ppm)
Frequency Stability Ver. Temperature			
50	3.7	467.637403	-0.21
40	3.7	467.637428	-0.15
30	3.7	467.637382	-0.25
20	3.7	467.637363	-0.29
10	3.7	467.637434	-0.14
0	3.7	467.637372	-0.27
-10	3.7	467.637373	-0.27
-20	3.7	467.637405	-0.20
Frequency Stability Ver. Input Voltage			
20	3.5	467.637420	-0.17
20	4.2	467.637366	-0.29

Note: The extreme voltage was declared by applicant.

******* END OF REPORT *******