

NA-1909D Series
Digital Radio

OWNER'S MANUAL

English

Preface

To help you ward off bodily injury or property loss that may arise from improper operation, please read all the information carefully before using our products.

Intended Use

Our products are designed to provide reliable wireless communication services for users across many industry sectors. In order to use the products safely and to achieve the best performance, they must be used as intended. The operator of the product is responsible for damage to the product or damage caused by the product if the product was used beyond the intended use instructions.

Intended use includes that:

- The product is used by users who have full knowledge of its RF exposure and can exercise control over their RF exposure to meet the occupational limits in FCC/ICNIRP and international standards.
- All the security instructions set forth in this document are always heeded.
- The general, national and in-house safety regulations are heeded.
- The product is exclusively used with the frequencies licensed by the respective authority.
- The product is configured appropriately by the dealer.

Besides, intended use also requires the product operator to be well-trained and to be familiar with the applicable standards, regulations and provisions.

RF Radiation Information

Compliance with RF Exposure Standards

The radio complies with the following RF energy exposure standards and guidelines:

- United States Federal Communications Commission, Code of Federal Regulations; 47 CFR § 1.1307, 1.1310 and 2.1093
- American National Standards Institute (ANSI) / Institute of Electrical and Electronic Engineers (IEEE) C95. 1:2005;

Canada RSS102 Issue 5 March 2015

- Institute of Electrical and Electronic Engineers (IEEE) C95.1:2005 Edition

RF Exposure Compliance and Control Guidelines and Operating Instructions

To control your exposure and ensure compliance with the occupational/controlled environmental exposure limits, always adhere to the following procedures.

Guidelines:

- Do not remove the RF Exposure Label from the device.
- User awareness instructions should accompany device when transferred to other users.
- Do not use this device if the operational requirements described herein are not met.

Operating Instructions:

- Transmit no more than the rated duty factor of 50% of the time. To transmit (talk), press the Push-to-Talk (PTT) key. To receive calls, release the PTT key. Transmitting 50% of the time, or less, is important because the radio generates measurable RF energy only when transmitting (in terms of measuring for standards compliance).
- Keep the radio unit at least 2.5 cm away from the face. Keeping the radio at the proper distance is important as RF exposure decreases with distance from the antenna. The antenna should be kept away from the face and eyes.
- When worn on the body, always place the radio in an approved holder, holster, case, or body harness or by use of the correct clip for this product. Use of non-approved accessories may result in exposure levels which exceed the FCC's occupational/controlled environmental RF exposure limits.
- Use of non-approved antennas, batteries, and accessories causes the radio to exceed the FCC RF exposure guidelines.
- Contact your local dealer for the product's optional accessories.

FCC Regulations

Federal Communication Commission (FCC) requires that all radio communication products should meet the

requirements set forth in the above standards before they can be marketed in the U.S, and the manufacturer shall post a RF label on the product to inform users of operational instructions, so as to enhance their occupational health against exposure to RF energy.

FCC Statement

This equipment has been tested and found to comply with the limits for a Class B digital device, pursuant to part 15 of FCC Rules. These limits are designed to provide reasonable protection against harmful interference in a residential installation. This equipment generates and can radiate radio frequency energy. If not installed and used in accordance with the instructions, it may cause harmful interference to radio communications. However, there is no guarantee that interference will not occur in a particular installation. Verification of harmful interference by this equipment to radio or television reception can be determined by turning it off and then on. The user is encouraged to try to correct the interference by one or more of the following measures:

- Reorient or relocate the receiving antenna. Increase the separation between the equipment and receiver.
- Connect the equipment into an outlet on a different circuit to that of the receiver's outlet.
- Consult the dealer or an experienced radio/TV technician for help.

Operation is subject to the following two conditions:

- This device may not cause harmful interference.
- This device must accept any interference received, including interference that may cause undesired operation.

Note: Changes or modifications to this unit not expressly approved by the party responsible for compliance could void the user's authority to operate the equipment.

IC Statement

The device has been tested and complies with SAR limits, users can obtain Canadian information on RF exposure and compliance.

Après examen de ce matériel aux conformité aux limites DAS et/ou aux limites d'intensité de champ RF, les utilisateurs peuvent sur l'exposition aux radiofréquences et la conformité and compliance d'acquérir les informations

correspondantes.

This device complies with Industry Canada license-exempt RSS standard(s).

Operation is subject to the following two conditions:

- This device may not cause harmful interference.
- This device must accept any interference received, including interference that may cause undesired operation.

Le présent appareil est conforme aux CNR d'Industrie Canada applicables aux appareils radio exempts de licence.

L'exploitation est autorisée aux deux conditions suivantes: (1) l'appareil ne doit pas produire de brouillage, et (2) l'utilisateur de l'appareil doit accepter tout brouillage radioélectrique subi, même si le brouillage est susceptible d'en compromettre le fonctionnement

EU Regulatory Conformance

As certified by the qualified laboratory, the product is in compliance with the essential requirements and other relevant provisions of the Directive 2014/53/EU. All applicable EU regulations are regarded (2006/66/EC , 2011/65/EU , 2012/19/EU).Please note that the above information is applicable to EU countries only.

Precautions for Portable Terminals

Operating Prohibitions

To protect you against any property loss, bodily injury or even death, be sure to observe the following safety instructions:

1. Do not operate the product in a location containing fuels, chemicals, explosive atmospheres and other flammable or explosive materials. In such location, only an approved Ex-protection model is allowed for use, but any attempt to assemble or disassemble it is strictly prohibited.
2. Do not operate the product near or in any blasting area.
3. Do not operate the product near any medical or electronic equipment that is vulnerable to RF signals.
4. Do not hold the product while driving.

5. Do not operate the product in any area where use of wireless communication equipment is completely prohibited.

■ Important Tips

To help you make better use of the product, be sure to observe the following instructions:

1. Do not use any unauthorized or damaged accessory.
2. Keep the product at least 2.5 centimeters away from your body during transmission.
3. Do not keep the product receiving at high volume for a long time.
4. For vehicles with an air bag, do not place the product in the area over the air bag or in the air bag deployment area.
5. Keep the product and its accessories out of reach of children and pets.
6. Please operate the product within the specified temperature range.
7. Continuous transmission for a long time may lead to heat accumulation within the product. In this case, please keep it at a proper location for cooling.
8. Handle the product with care.
9. Do not disassemble, modify or repair the product and its accessories without authorization.

■ Protect your hearing

1. When using the radio without a headset or earpiece, do not place the radio's speaker directly against your ear.
2. Use the lowest volume necessary to do your job.
3. Turn up the volume only if you are in noisy surroundings.
4. Turn down the volume before adding headset or earpiece.
5. Limit the amount of time you use headsets or earpieces at high volume.
6. Use careful with the earphone maybe possible excessive sound pressure from earphones and headphones can cause hearing loss

Precautions for Batteries

■ Charging Prohibitions

To protect you against any property loss, bodily injury or even death, be sure to observe the following safety instructions:

1. Do not charge or replace your battery in a location containing fuels, chemicals, explosive atmospheres and other flammable or explosive materials.
2. Do not charge your battery that is wet. Please dry it with a soft and clean cloth prior to charge.
3. Do not charge your battery suffering deformation, leakage and overheat.
4. Do not charge your battery with an unauthorized charger.
5. Do not charge your battery in a location where strong radiation is present.
6. Overcharge shall always be prohibited for it may shorten the life of your battery.

■ Maintenance Instructions

To help your battery work normally or prolong its life, be sure to observe the following instructions:

1. Accumulated dust on charging connector may affect normal charging. Please use a clean and dry cloth to wipe it on a regular basis.
2. It is recommended to charge the battery under 5°C~40°C. Violation of the said limit may cause battery life reduction or even battery leakage.
3. To charge a battery attached to the product, turn it off to ensure a full charge.
4. Do not remove the battery or unplug the power cord during charging to ensure a smooth charging process.
5. Do not dispose of the battery in fire.
6. Do not expose the battery to direct sunlight for a long time nor place it close to other heating sources.
7. Do not squeeze and penetrate the battery, nor remove its housing.

■ Transportation Instructions

1. Damaged batteries must not be transported.
2. To avoid short circuit, separate the battery from metal parts or from each other if two or more batteries are transported in one packaging.
3. The radio must be switched off and secured against switch-on, if the battery is attached.

The content of the shipment must be declared in the shipping documents and by a Battery Shipping Label on the packaging. Contact your hauler for the local regulations and further information.

Precautions for Disposal

Once the service life of our products (including but not limited to radios and batteries) has ended, they shall not be disposed as household garbage. Their recycling and disposal shall satisfy your local regulations.

Content of the packaging

- | | |
|--------------------|-------------------------|
| • 1 Radio | • 1 Li-Ion battery pack |
| • 1 Adapter | • 1 Wrist strap |
| • 1 Belt clip | • 1 Antenna |
| • 1 Owner's Manual | • 1 Headset |
| • 1 Desk Charger | |

If any item is missing, please verify with your dealer.

Main characteristics

- Encrypted calls (up to 32 key configurations), making calls more confidential
- Speech noise reduction to significantly improve call quality in noisy environments
- Support non-standard sub tone and frequency hopping functions, Enhance signal concealment and anti-interference ability
- One-touch frequency matching and quick group formation, Simplify CPS programming operations, quickly match and connect specified channels with just one click, allowing users to quickly create or join groups
- UHF410-469MHz Transceiver
- Output power: 5W
- Channel spacing: 12.5 KHz
- Analog/ Encrypted channel Scan
- Vocal tuning
- Battery save
- Channel Monitor
- Analog Squelch
- 51 CTCSS tones and 210 DCS codes
- TOT (Time out timer)
- 2pin Kenwood accessory jack

Main controls and parts of the radio

1. Antenna
2. PTT key
3. SK1: Monitor key
4. SK2: Battery access key
5. Channel switch
6. Power switch/volume knob
7. Accessory interface
8. Built-in speaker
9. Built-in microphone
10. Status Indicator (TX lights up red; RX lights up green)
11. Battery latch
12. Type-C charge jack
13. Type-C charge Indicator

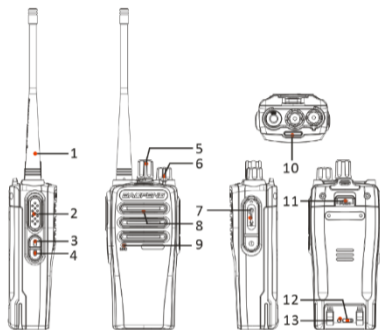

LED Status Indications

The top LED will help you to identify the current radio status.

LED Indication	Radio Status
Constant Red	Transmitting
Constant Green	Analog Receiving
Flashes Green	Analog Scan
Constant Yellow	Encryption Receiving
Flashes Yellow	encryption Scan

Charging the Battery

Use the approved charger to charge the battery.

Read the Safety Information Booklet before charging.

Before initial use, fully charge the battery to ensure optimum performance.

To charge the battery, do as follows:

(1) Insert the output connector of the power adapter into the port on the back of the charger.

(2) Plug the power adapter into a power outlet.

(3) Place the battery into the charger, and then switch the power outlet on.

To determine the charging status, check the light-emitting diode (LED) indicator on the charger according to the following table:

LED Indication	Charge Status
Green	No Battery
Constant Red	The battery is charging.
Constant Green	The battery is fully charged.

You can also charge the radio with battery attached. It is recommended that your radio remain turned off during charging.

Type-C Charge

1. Your radio supports the TYPE-C charging method. Connect the TYPE-C cable to the Type-C connector of the power supply unit and the battery.
2. Ensure that the Type-C socket at the bottom of the battery is in good contact with the charging terminal of the cable. The charging indicator light at the bottom of the battery turns red and charging begins.
3. It takes approximately 2-5 hours to fully charge the battery. The charging indicator light at the bottom of the battery

is off - charging is complete.

When the charging indicator light at the bottom of the battery goes off, it indicates that the charging is complete. Remove the cable from the Type-C port at the bottom of the battery.

Baofeng recommends your radio is turned off while being charged.

Operations

Power on/off and volume adjustment

Rotate the **[Power/Volume]** knob clockwise to turn the radio on. Rotate the control clockwise /counter-clockwise to adjust the volume level as you prefer.

Rotate the **[Power/Volume]** knob to adjust the volume. Turn clockwise to increase the volume and counterclockwise to decrease the volume.

·To turn the radio off, rotate the control counter-clockwise till hearing a mechanical "click".

·If voice prompts are enabled, they will be accompanied by "Power on and channel number".

Select a Channel

The radios can store up to 16 channels, and the channel type allows programming to analog or/and encrypted.

In standby mode, turn the channel knob to select the channel you want. When the voice prompt function is enabled, the corresponding channel is broadcasted by voice.

·If the channel is encrypted, it will be accompanied by "Encryption and channel number".

Attention: It is necessary to set the members of the group on the same channel in order to communicate through radios.

Making a Call

To communicate, all radios in your group must be set to the same channel. Briefly press the **[SK1]** (Monitor key) to enable the Monitor feature in order to make sure that the frequency is not busy, and then press the **[PTT]** key. Release the **[PTT]** key to receive. Only one user at a time can talk during radio communications. Therefore, it is important not

to transmit when you are receiving a communication and use the transmission mode sparingly to allow other users to talk. Transmission consumes a significant amount of energy and should therefore be used sparingly to prolong the battery life. If you are unable to contact a station that you have no problems in receiving, the station may be using CTCSS tones or DCS codes.

Making a Encryption Call

-Select an encryption channel, Press and hold **[PTT]** key, the radios is in the transmitting state, and the red indicator light is constantly on. Then speak in a normal tone into the microphone.

-After releasing the **[PTT]** key, the yellow light briefly flashes once, and the radio is in an acceptable state. When receiving a call, the yellow indicator light remains on.

Note: Set the group members on the same channel and encryption sequence (0-31) to achieve interconnection.

Monitor Function

Before using the monitor function, check whether it is an analog channel. The monitor function is only available for analog channels.

On analog channels, you can use **[SK1]** (Monitor key) to hear weaker signals that are difficult to hear during normal operation, and to adjust the volume when there is no signal on the channel you have selected.

In standby mode, press and hold **[SK1]** (Monitor key) to turn on the monitor function. Release **[SK1]** (Monitor key) to exit the monitor state.

One-touch access to battery level

In standby mode, long press **[SK2]** (Battery access) will be accompanied by a voice prompting the current battery level.

-High battery level: sufficient battery level.

-Medium battery level: average battery level.

-Low power: insufficient power, please charge in time to replenish the power

Channel memory information access

In standby mode, press and hold **[SK1]** key and then press **[SK2]** key briefly, it will broadcast the parameter information such as transmit frequency, receive frequency, CTCSS/DCS, transmit power, etc. stored in the current channel.

Channel Scanning

Note: Scanning can only be realized by setting the channel's scanning add to on through the CPS program software and turn on the unit's scanning function.

The scan function is used to monitor to the signals programmed on the radio's channels. During scanning, the radio detects signals on each channel and stops only on channels that have signals.

Note: Channels that have not been added are not scanned.

The radio will remain on the communication channel until that signal disappears. Scanning will resume 5 seconds after the signal disappears unless a new signal is detected within that delay time.

Note: The scanning feature is only available if your local dealer has programmed at least two channels for the radios. In addition, at least two channels must not be programmed for Scan Delete. Consult your local dealer for details on how to use the Scan feature with Coded Squelch or Select Call.

- 1) Press and hold the **[SK1]** key to turn on the radio to enter channel scanning.
- 2) Enter analog scanning on analog channel, the indicator is flashing green. Enter encrypted scanning on encrypted channel, the indicator light is flashing yellow. When scanning is paused on a channel that is always lit, press and hold the **[PTT]** key will make a callback on the active channel.
- 3) At any time during scanning, you simply press the **[SK1]** key the radio pauses scanning. The radio returns to transmitting on the channel on which the last signal was received. If a valid signal is received during scanning, the radio returns to the channel on which scanning started and transmits.
- 4) Scanning Mode: In carrier scanning mode, scanning stops when a signal is scanned, and scanning continues after the carrier signal is lost for 5 seconds. After scanning the signal, the voice prompts the serial number of the channel scanned.

Prompt voice switch settings

The encoder is selected to the 10th channel. Press and hold the **[PTT]+[SK1]** to turn on the radio, and turn the prompt

voice on or off.

Turn on the prompt voice function, and there will be voice prompts when the encoder is turned on or operated. If you turn off the prompt voice function, there is only a "beep" prompt when you turn on or operate the encoder.

VOX

The VOX feature enables hands free conversations without using PTT: just speak in the direction of the microphone and the communication will be automatically activated. The VOX sensitivity can be adjusted in 5 different levels (1...5) through the programming software:

Level 2 is set by default and has the lowest VOX sensitivity, 5 is the lowest one.

With the programming software you can enable/disable the VOX feature and select the sensitivity levels.

NOTE: In channel 5, press and hold the [PTT]+[SK1] keys to turn on the radio and prompt "VOX on, welcome 5" to turn on/off voice control.

Frequency sweep function

Rotate the channel knob to Channel 1, press and hold the [PTT]+[SK1] key to turn on the radio. The voice will announce "Power On" to enter the sweep function and the green light will flash; Press the [SK1] key to prompt a "beep" sound and the green light remains on, and start scanning. After scanning, it will be automatically stored and prompted with two beeps. (The green light remains on during scanning, and the green light flashes when scanning is stopped)

Rotate to channel 2, press the [SK1] key to continue scanning. After scanning, it will be automatically stored and prompted with a "beep" sound, with the indicator light as described above;

Rotate to channel 3 and press the [SK1] key to continue scanning. After scanning, it will be automatically stored and prompted with a "beep" sound; Operate in sequence until channel 16.

Complete the frequency sweep task, shut down and restart to exit the frequency sweep mode, and the frequency sweep task ends.

Quick group formation (Wireless clone function)

Rotate the channel knob to channel 2, press and hold the **[PTT]+[SK1]** key to turn on both the transmitter and receiver. The receiver and transmitter prompt "beep" to enter wireless replication. When the transmitter presses the **[PTT]** key, the red light remains on, and the receiver green light automatically remains on. Copy all the configuration parameters of channels 1-16 of the transmitter, and the receiver prompts "beep" twice to complete the replication. Both prompt lights turn off and automatically restart, the replication task has ended.

Voice frequency hopping

Set frequency hopping on/off for each channel through CPS software. When the frequency hopping function is enabled, it cannot communicate with the regular settings.

Note: Channels with frequency hopping function must be synchronously set with CTCSS or DCS.

CTCSS/DCS tones

CTCSS and DCS tones are similar to access codes and enable the radio to communicate only with the users that are tuned on the same channel and have set the same code. For each channel, you can set up to 51 CTCSS tones and 210 DCS codes. The CTCSS/DCS tones are a sort of "access codes" and enable the radio to communicate only with the other users set on the same frequency and on the same CTCSS/DCS tone.

Quick operation radio

Without CPS programming software, you can perform the following quick operations through the combination of **[PTT]+[SK1]**:

- On the 1th channel, press and hold the **[PTT]+[SK1]** to turn on the radios, and the green light flashes to perform frequency scanning.
- On the 2th channel, press and hold the **[PTT]+[SK1]** to open the radios, which can be wirelessly copied to quickly group up.
- On the 5th channel,, press and hold the **[PTT]+[SK1]** to turn on the radio and turn the VOX function on or off.

Accompanied by a voice prompt VOX On or VOX Off.

- On the 10th channel, press and hold the **[PTT]+[SK1]** to turn on the radio and turn on or off the prompt voice function.
 - On the 15th channel, press and hold the **[PTT]+[SK1]** to turn on the radio and switch the prompt language between Chinese and English.
- Channel scanning: any channel, hold down the **[SK1]** key to turn on the radio to enter scanning.

Trouble shooting guide

PROBLEM	SOLUTION
The radio doesn't switch on	The battery may be exhausted. Recharge it. Uncorrected installation.
Battery recharge doesn't last long	The battery pack is over. Change it with a new one. Battery pack is not completely charged.
Reception led turns on but no sound heard	Make sure the volume is not too low. Make sure to have the same CTCSS and DCS codes of your group
The keypad doesn't work	Keypad lock function hasn't been enabled
Reception of other group signal while transmitting	Change another CTCSS/DCS for your group

NOTE: *If the above solutions cannot fix your problems, or you may have some other queries, please contact your dealer for more technical support.*

Technical specifications

General

Frequency range	410~ 469MHz
Working temperature	-20°/+55° C
Operating voltage	7.4 V
Data Rate for Digital	10248 bps in a 12.5 kHz channel
Dimensions	65 x 41 x 148mm (without antenna)
Weight	300 g (Battery pack included)
Antenna impedance	50Ω

Transmitter

Frequency stability	±2.5PPM
Output power	5W
Max frequency deviation	≤2,5KHz
Audio distortion	≤3%
Adjacent channel power	< 60 dB

Receiver

RF sensibility	<0.2UV@20 dB SINAD
Audio distortion	≤3%
Audio response	300Hz ÷ 3KHz
Adjacent channel selectivity	Within European legal terms

WARNING: Direct plug-in ac/dc power supply must be used for disconnecting the transceiver from the mains; the desktop charger must be positioned close to the unit and easily accessible.

Disclaimer

The Company endeavors to achieve the accuracy and completeness of this manual, but no warranty of accuracy or reliability is given. All the specifications and designs are subject to change without notice due to continuous technological development. No part of this manual may be copied, modified, translated, or distributed in any manner without the prior written consent of the Company.

We do not guarantee, for any particular purpose, the accuracy, validity, timeliness, legitimacy or completeness of the third-party products and contents involved in this manual.

PO FUNG ELECTRONIC (HK) INTERNATIONAL GROUP COMPANY LIMITED

Room 1508, 15/F, Office Tower II, Grand Plaza, 625 Nathan Road, Kowloon, Hong Kong

E-mail: wangjianhui@baofengradio.com

[Http://www.baofengradio.com](http://www.baofengradio.com)

Print version: BF-1909D_V1.0