

OFF-ROAD PATHFINDER RC CAR INSTRUCTION MANUAL

REMOTE CONTROL FUNCTION

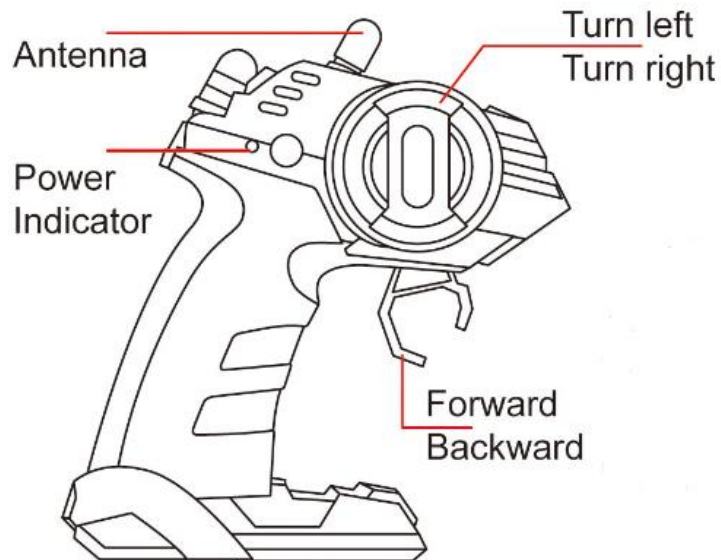

CAR CHARGING INSTRUCTIONS

1. Open the battery cover on the back of remote control car and remove the battery pack from the battery compartment.
2. Connect the USB charging cable to the corresponding socket. When charging, the LED light is on. When the charging is fully, the led light is off. And the charging time is about 70mins.
3. Install the battery pack into the battery case, conect it, replace the battery cover, and secure it with a screwdriver.

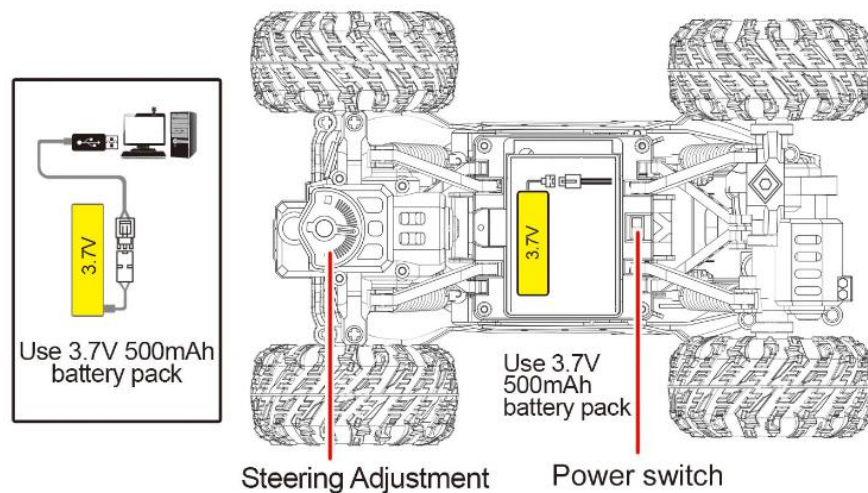

FCC Statement:

This equipment has been tested and found to comply with the limits for a Class B digital device, pursuant to part 15 of the FCC Rules. These limits are designed to provide reasonable protection against harmful interference in a residential installation. This equipment generates, uses and can radiate radio frequency energy and, if not installed and used in accordance with the instructions, may cause harmful interference to radio communications. However, there is no guarantee that interference will not occur in a particular installation. If this equipment does cause harmful interference to radio or television reception, which can be determined by turning the equipment off and on, the user is encouraged to try to correct the interference by one or more of the following measures:

- 1) Reorient or relocate the receiving antenna.
- 2) Increase the separation between the equipment and receiver.
- 3) Connect the equipment into an outlet on a circuit different from that to which the receiver is connected.
- 4) Consult the dealer or an experienced radio/TV technician for help.

Caution: Any changes or modifications to this device not explicitly approved by manufacturer could void your authority to operate this equipment.

This device complies with part 15 of the FCC Rules. Operation is subject to the following two conditions:

(1) This device may not cause harmful interference, and (2) this device must accept any interference received, including interference that may cause undesired operation.