



# Operation Manual

## Product

### SMC Wireless System Compact Remote

## Model/ Series/ Product Number

*EX600-WLXB1 / EX600-WLYB1*

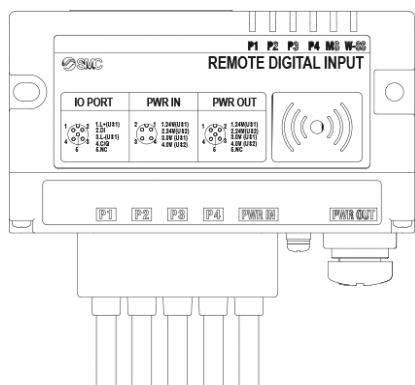

EX600-WLXB1

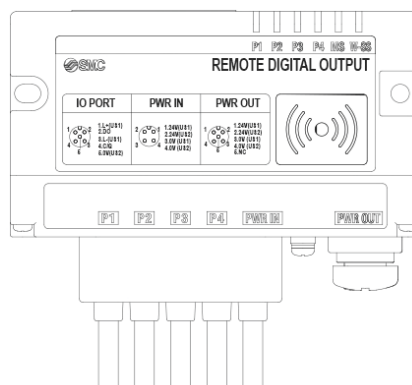

EX600-WLYB1

# SMC Corporation

# Contents

<b>Safety Instructions</b> .....	<b>2</b>
<b>SMC Wireless System</b> .....	<b>10</b>
Summary and Outline .....	10
System Construction .....	11
<b>Compact Wireless Remotes for IO-Link Devices</b> .....	<b>12</b>
Summary and Outline .....	12
IO-Link Compatibility .....	13
How to Order .....	14
<b>Summary of Product Parts</b> .....	<b>15</b>
EX600-WLXB1 / EX600-WLYB1 .....	15
<b>Setting and Adjustment</b> .....	<b>19</b>
Flow Chart for Bringing the Wireless System into Operation .....	19
PC Application for Managing Settings .....	20
Setting and Adjusting the Wireless Unit .....	24
<b>Mounting and Installing a Unit</b> .....	<b>31</b>
EX600-WLXB1 / EX600-WLYB1 .....	31
<b>Troubleshooting</b> .....	<b>32</b>
<b>Technical Information</b> .....	<b>38</b>
EX600-WL*B1 (Compact Wireless Remote Unit for IO-Link) I/O Map .....	38
SMC Wireless System I/O Map Configuration .....	42
Short Circuit Detection .....	43
Forced Output .....	43
<b>Additional Information</b> .....	<b>44</b>
Relation between Number of Module Occupied Points and Process Data Size .....	44
Wireless System Parameter List .....	46
Example of Output Device Connection .....	47
<b>Specifications</b> .....	<b>48</b>
Dimensions .....	48
Specifications .....	49
Terminology .....	51
<b>Accessories (Sold Separately)</b> .....	<b>53</b>



# Safety Instructions

These safety instructions are intended to prevent hazardous situations and/or equipment damage. These instructions indicate the level of potential hazard with the labels of "Caution", "Warning" or "Danger".

They are all important notes for safety and must be followed in addition to International Standards (ISO/IEC)\*1), and other safety regulations.

\*1) ISO 4414: Pneumatic fluid power -- General rules relating to systems.

ISO 4413: Hydraulic fluid power -- General rules relating to systems.

IEC 60204-1: Safety of machinery -- Electrical equipment of machines .(Part 1: General requirements)

ISO 10218: Manipulating industrial robots -Safety.

etc.



## Caution

**Caution** indicates a hazard with a low level of risk which, if not avoided, could result in minor or moderate injury.



## Warning

**Warning** indicates a hazard with a medium level of risk which, if not avoided, could result in death or serious injury.



## Danger

**Danger** indicates a hazard with a high level of risk which, if not avoided, will result in death or serious injury.

## Warning

### 1. The compatibility of the product is the responsibility of the person who designs the equipment or decides its specifications.

Since the product specified here is used under various operating conditions, its compatibility with specific equipment must be decided by the person who designs the equipment or decides its specifications based on necessary analysis and test results.

The expected performance and safety assurance of the equipment will be the responsibility of the person who has determined its compatibility with the product.

This person should also continuously review all specifications of the product referring to its latest catalog information, with a view to giving due consideration to any possibility of equipment failure when configuring the equipment.

### 2. Only personnel with appropriate training should operate machinery and equipment.

The product specified here may become unsafe if handled incorrectly.

The assembly, operation and maintenance of machines or equipment including our products must be performed by an operator who is appropriately trained and experienced.

### 3. Do not service or attempt to remove product and machinery/equipment until safety is confirmed.

1. The inspection and maintenance of machinery/equipment should only be performed after measures to prevent falling or runaway of the driven objects have been confirmed.

2. When the product is to be removed, confirm that the safety measures as mentioned above are implemented and the power from any appropriate source is cut, and read and understand the specific product precautions of all relevant products carefully.

3. Before machinery/equipment is restarted, take measures to prevent unexpected operation and malfunction.

### 4. Contact SMC beforehand and take special consideration of safety measures if the product is to be used in any of the following conditions.

1. Conditions and environments outside of the given specifications, or use outdoors or in a place exposed to direct sunlight.

2. Installation on equipment in conjunction with atomic energy, railways, air navigation, space, shipping, vehicles, military, medical treatment, combustion and recreation, or equipment in contact with food and beverages, emergency stop circuits, clutch and brake circuits in press applications, safety equipment or other applications unsuitable for the standard specifications described in the product catalog.

3. An application which could have negative effects on people, property, or animals requiring special safety analysis.

4. Use in an interlock circuit, which requires the provision of double interlock for possible failure by using a mechanical protective function, and periodical checks to confirm proper operation.



# Safety Instructions

## Caution

### **1. The product is provided for use in manufacturing industries.**

The product herein described is basically provided for peaceful use in manufacturing industries. If considering using the product in other industries, consult SMC beforehand and exchange specifications or a contract if necessary.  
If anything is unclear, contact your nearest sales branch.

## Limited warranty and Disclaimer/Compliance Requirements

The product used is subject to the following "Limited warranty and Disclaimer" and "Compliance Requirements".

Read and accept them before using the product.

### Limited warranty and Disclaimer

- 1. The warranty period of the product is 1 year in service or 1.5 years after the product is delivered, whichever is first.\*2)**  
**Also, the product may have specified durability, running distance or replacement parts. Please consult your nearest sales branch.**

- 2. For any failure or damage reported within the warranty period which is clearly our responsibility, a replacement product or necessary parts will be provided.**  
**This limited warranty applies only to our product independently, and not to any other damage incurred due to the failure of the product.**

- 3. Prior to using SMC products, please read and understand the warranty terms and disclaimers noted in the specified catalog for the particular products.**

**\*2) Vacuum pads are excluded from this 1 year warranty.**

**A vacuum pad is a consumable part, so it is warranted for a year after it is delivered.**

**Also, even within the warranty period, the wear of a product due to the use of the vacuum pad or failure due to the deterioration of rubber material are not covered by the limited warranty.**

### Compliance Requirements

- 1. The use of SMC products with production equipment for the manufacture of weapons of mass destruction (WMD) or any other weapon is strictly prohibited.**
- 2. The exports of SMC products or technology from one country to another are governed by the relevant security laws and regulation of the countries involved in the transaction. Prior to the shipment of a SMC product to another country, assure that all local rules governing that export are known and followed.**

## Operator

- ◆ This operation manual is intended for those who have knowledge of machinery using pneumatic equipment, and have sufficient knowledge of assembly, operation and maintenance of such equipment. Only those persons are allowed to perform assembly, operation and maintenance.
- ◆ Read and understand this operation manual carefully before assembling, operating or providing maintenance to the product.

### ■ Safety Instructions

#### **Warning**

- Do not disassemble, modify (including changing the printed circuit board) or repair.  
An injury or failure can result.
- Do not operate or set with wet hands.  
This may lead to an electric shock.
- Do not operate the product outside of the specifications.  
Do not use for flammable or harmful fluids.  
Fire, malfunction, or damage to the product can result.  
Verify the specifications before use.
- Do not operate in an atmosphere containing flammable or explosive gases.  
Fire or an explosion can result.  
This product is not designed to be explosion proof.
- If using the product in an interlocking circuit:
  - Provide a double interlocking system, for example a mechanical system.
  - Check the product regularly for proper operation.Otherwise malfunction can result, causing an accident.
- The following instructions must be followed during maintenance:
  - Turn off the power supply.
  - Stop the air supply, exhaust the residual pressure and verify that the air is released before performing maintenance.Otherwise an injury can result.

## **Caution**

- When handling the unit or assembling/replacing units:
  - Do not touch the sharp metal parts of the connector or plug for connecting units.
  - Take care not to hit your hand when disassembling the unit.  
The connecting portions of the unit are firmly joined with seals.
  - When joining units, take care not to get fingers caught between units.  
An injury can result.

- After maintenance is complete, perform appropriate functional inspections.  
Stop operation if the equipment does not function properly.  
Safety cannot be assured in the case of unexpected malfunction.

- Provide grounding to assure noise resistance of the Fieldbus system.  
Individual grounding should be provided close to the product with a short cable.

## **Caution**

### Notice:

Changes or modifications not expressly approved by the manufacturer could void the user's authority to operate the equipment.

### NOTE:

This equipment has been tested and found to comply with the limits for a Class A digital device, pursuant to Part 15 of the FCC Rules.

These limits are designed to provide reasonable protection against harmful interference when the equipment is operated in a commercial environment.

This equipment generates, uses, and can radiate radio frequency energy and, if not installed and used in accordance with the instruction manual, may cause harmful interference to radio communications.

Operation of this equipment in a residential area is likely to cause harmful interference in which case the user will be required to correct the interference at his own expense.

This device complies with Industry Canada's licence-exempt RSSs. Operation is subject to the following two conditions:

- (1) This device may not cause interference; and
- (2) This device must accept any interference, including interference that may cause undesired operation of the device.

Le présent appareil est conforme aux CNR d'Industrie Canada applicables aux appareils radio exempts de licence. L'exploitation est autorisée aux deux conditions suivantes:

- (1) l'appareil ne doit pas produire de brouillage, et
- (2) l'utilisateur de l'appareil doit accepter tout brouillage radioélectrique subi, même si le brouillage est susceptible d'en compromettre le fonctionnement.

 **Caution**

When operating the product, please be sure to maintain a separation distance of at least 20cm between your body (excluding fingers, hands, wrists, ankles and feet) and the product to meet RF exposure safety requirements as determined by FCC and Innovation, Science and Economic Development Canada. Installation of this device must ensure that at 20cm separation distance is maintained between the device and end users.

## ■NOTE

- Follow the instructions given below when designing, selecting and handling the product.
- The instructions on design and selection (installation, wiring, environment, adjustment, operation, maintenance, etc.) described below must also be followed.
  - \*Product specifications
    - Use the specified voltage.  
Otherwise failure or malfunction can result.
    - Reserve a space for maintenance.  
Allow sufficient space for maintenance when designing the system.
    - Do not remove any nameplates or labels.  
This can lead to incorrect maintenance, or misreading of the operation manual, which could cause damage or malfunction to the product.  
It may also result in non-conformity to safety standards.
    - Beware of inrush current when the power supply is turned on.  
Some connected loads can apply an initial charge current which will activate the over current protection function, causing the unit to malfunction.
  - Product handling
    - \*Installation
      - Do not drop, hit or apply excessive shock to the SI unit.  
Otherwise damage to the product can result, causing malfunction.
      - Tighten to the specified tightening torque.  
If the tightening torque is exceeded the mounting screws may be broken.  
IP67 protection cannot be guaranteed if the screws are not tightened to the specified torque.
      - Never mount a product in a location that will be used as a foothold.  
The product may be damaged if excessive force is applied by stepping or climbing onto it.
    - \*Wiring
      - Avoid repeatedly bending or stretching the cables, or placing heavy load on them.  
Repetitive bending stress or tensile stress can cause breakage of the cable.
      - Wire correctly.  
Incorrect wiring can break the product.
      - Do not perform wiring while the power is on.  
Otherwise damage to the wireless unit and/or input or output device can result, causing malfunction.
      - Do not route wires and cables together with power or high voltage cables.  
Otherwise the wireless unit and/or input or output device can malfunction due to interference of noise and surge voltage from power and high voltage cables to the signal line.  
Route the wires (piping) of the wireless unit and/or input or output device separately from power or high voltage cables.
      - Confirm proper insulation of wiring.  
Poor insulation (interference from another circuit, poor insulation between terminals, etc.) can lead to excess voltage or current being applied to the product, causing damage.
      - Take appropriate measures against noise, such as using a noise filter, when the Fieldbus system is incorporated into equipment.  
Otherwise noise can cause malfunction.



#### \*Environment

- Select the proper type of protection according to the environment of operation.

IP67 protection class is achieved when the following conditions are met.

(1) The units are connected properly with fieldbus cable with M12 connector and power cable with M12 (M8) connector.

(2) Suitable mounting of each unit and manifold valve.

(3) Be sure to fit a waterproof cap on any unused connectors.

If using in an environment that is exposed to water splashes, please take measures such as using a cover.

Do not use in an environment where moisture or water vapor are present. Otherwise failure and malfunction can result.

- Do not use in a place where the product could be splashed by oil or chemicals.

If the product is to be used in an environment containing oils or chemicals such as coolant or cleaning solvent, even for a short time, it may be adversely affected (damage, malfunction etc.).

- Do not use the product in an environment where corrosive gases or fluids could be splashed.

Otherwise damage to the product and malfunction can result.

- Do not use in an area where surges are generated.

If there is equipment generating large surge near the unit (magnetic type lifter, high frequency inductive furnace, welding machine, motor, etc.), this can cause deterioration of the internal circuitry element of the unit or result in damage. Take measures against the surge sources, and prevent the lines from coming into close contact.

- When a surge-generating load such as a relay, valve or lamp is driven directly, use a product with a built-in surge absorbing element.

Direct drive of a load generating surge voltage can damage the unit.

- The product is CE marked, but not immune to lightning strikes. Take measures against lightning strikes in the system.

- Prevent foreign matter such as dust or wire debris from getting inside the product.

- Mount the product in a place that is not exposed to vibration or impact.

Otherwise failure or malfunction can result.

- Do not use the product in an environment that is exposed to temperature cycle.

Heat cycles other than ordinary changes in temperature can adversely affect the inside of the product.

- Do not expose the product to direct sunlight.

If using in a location directly exposed to sunlight, shade the product from the sunlight.

Otherwise failure or malfunction can result.

- Keep within the specified ambient temperature range.

Otherwise malfunction can result.

- Do not operate close to a heat source, or in a location exposed to radiant heat.

Otherwise malfunction can result.

#### \*Adjustment and Operation

- Please refer to the I/O configuration manual for details of parameter settings.

- Perform settings suitable for the operating conditions.

Incorrect setting can cause operation failure.

(Refer to Setting and Adjustment.)

- Please refer to the PLC manufacturer's manual etc. for details of programming and addresses.

For the PLC protocol and programming refer to the relevant manufacturer's documentation.

#### \*Maintenance

- Turn off the power supply, stop the supplied air, exhaust the residual pressure and verify the release of air before performing maintenance.

There is a risk of unexpected malfunction.

- Perform regular maintenance and inspections.

There is a risk of unexpected malfunction.

- After maintenance is complete, perform appropriate functional inspections.

Stop operation if the equipment does not function properly.

Otherwise safety is not assured due to an unexpected malfunction or incorrect operation.

- Do not use solvents such as benzene, thinner etc. to clean each unit.

They could damage the surface of the body and erase the markings on the body.

Use a soft cloth to remove stains.

For heavy stains, use a cloth soaked with diluted neutral detergent and fully squeezed, then wipe up the stains again with a dry cloth.

#### <Important>

- The product is certified as wireless equipment in accordance with the Radio Act and the certification of construction type has been obtained. Customers do not need to apply for a license to use this equipment.  
Be sure to comply with the following precautions.
  - Do not disassemble or modify the product. Disassembly and modification are prohibited by law.
  - This product is compliant with the Radio Act in Japan. For use in other countries, please consult SMC.
- This product communicates by radio waves, and the communication may stop instantaneously due to ambient environments and operating methods. SMC will not be responsible for any secondary failure which may cause an accident or damage to other devices or equipment.
- When several units are installed close to each other, slight interference may occur due to the characteristics of the wireless product.
- Radio waves emitted by this product may adversely affect implantable medical devices such as implantable cardiac pacemakers and implantable defibrillators.  
For precautions regarding the use of equipment or devices that may adversely affect performance, refer to the catalogue or instruction manual of the device or equipment, or contact the manufacturer directly.
- The communication performance is affected by the ambient environment, therefore please perform communication testing before use.

# SMC Wireless System

## Summary and Outline

This SMC wireless system is an I/O distributed system which can be wirelessly connected. It consists of a combination of the base which has upper level communication (such as PLC) and wireless connection function and the remote which offers wireless connection.

A paired remote group that includes a base unit is controlled by the upper-level control device (PLC) as a single system, and the maximum number of I/O points per 1 system can be 1280 points (160 bytes) / 1280 points (160 bytes).

By registering the Product ID (PID) which are uniquely assigned for each product to both the base and remote, individual units can be uniquely identified to prevent malfunction even when multiple base and remote units are operated in the same area.

The packet of the wireless transmit and receive data is encrypted. It is therefore difficult to manipulate the data.

The SMC wireless system has the following features.

- Quick start-up takes 0.25 seconds (minimum) to connect to the system when the remote is powered. \*1
- Parameter setting by Near Field Communication (NFC) using a PC (no HW setting).
- The maximum number of system I/O points is 1280 for input and 1280 for output. \*2,3
- A maximum of 127 remotes can be registered to one base. \*4
- The maximum number of base I/O points is 128 for input and 128 for output.
- The maximum number of remote I/O points is 256 for input and 256 for output.

\*1 The base is in start-up mode, and will change depending on the remote power-on timing and external influences.

\*2 The maximum number of I/O points is 1280 for input and 1280 for output. When exceeding 1280 points, the unit I/O is not recognized.

There might be communication delay depending on the communication load status.

\*3 Total number of base I/O points and registered remote I/O points.

\*4 The maximum number of units that can be connected is 127. If 127 units is exceeded, the unit I/O will not be recognized.

There might be communication delay depending on the communication load status.

Refer to the Operation Manual for the SMC Wireless System EtherNet/IP™, PROFINET type for details on using a base.

# System Construction

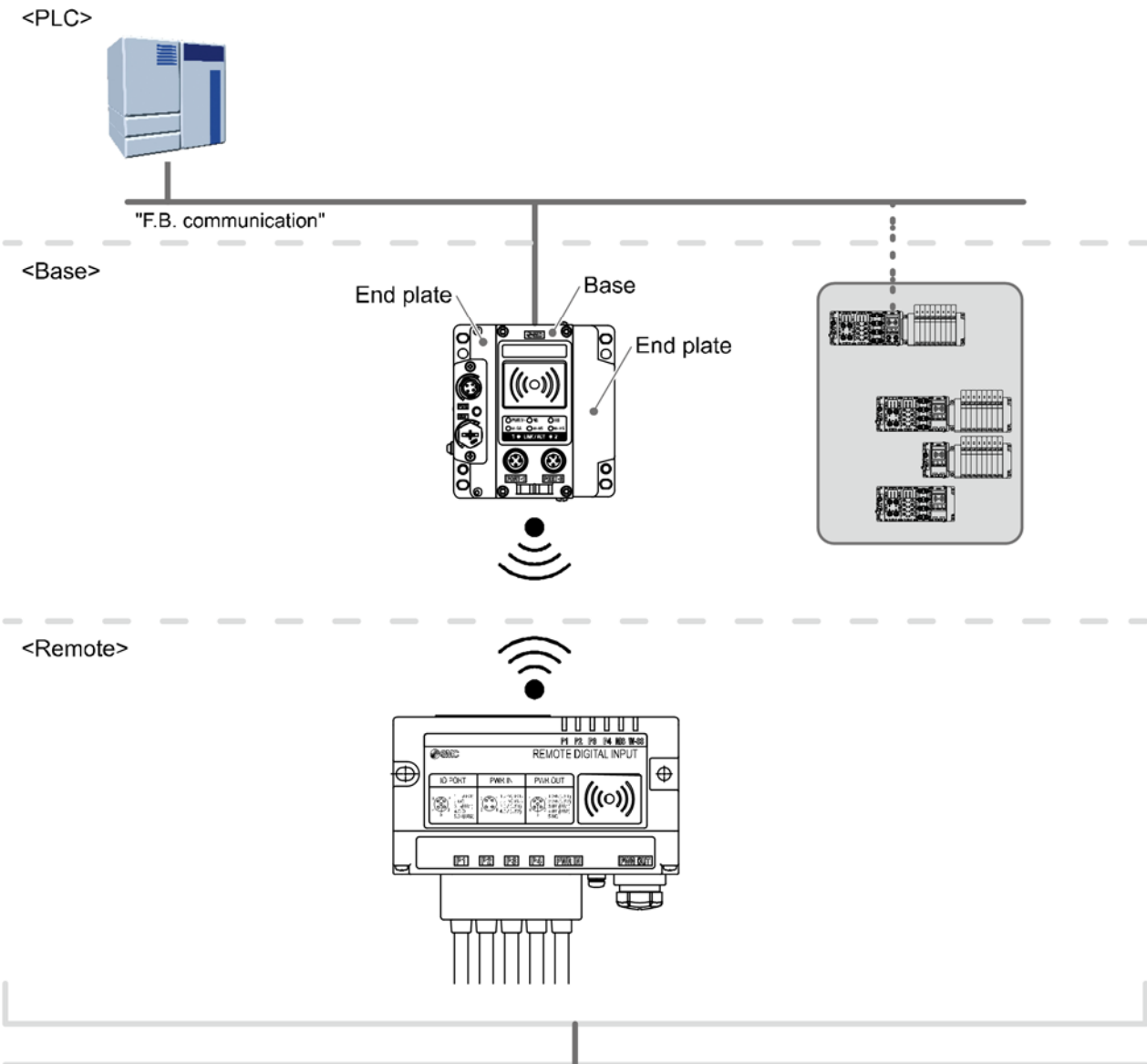

## <Connectable devices>

IO-Link devices: Pressure switch, digital flow switch, electro-pneumatic regulator, position sensor, SI unit (solenoid valve)

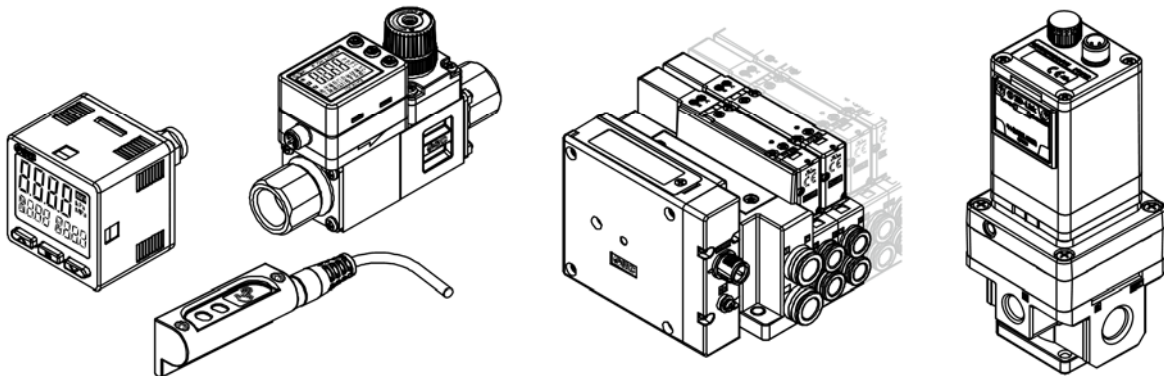

Digital input devices: Pressure switch, flow switch, auto switch, other switches (proximity/photoelectric/limit switch, etc.)  
 Digital output devices: Solenoid valve

# Compact Wireless Remotes for IO-Link Devices

## Summary and Outline

The EX600-WLXB1 / EX600-WLYB1 are compact wireless remote units for IO-Link devices. The lineup consists of two modules differing in their I/O port pin 2 specification, with the digital input module being EX600-WLXB1 (input type) and the digital output module being EX600-WLYB1 (output type). Refer to connector I/O (p. 17) for details. One port each are provided for power IN and power OUT, supporting daisy chain connection. I/O ports and the power IN port are M12 grommet type (except power OUT). When using a daisy chain connection, pay attention to the current consumption of connected devices.

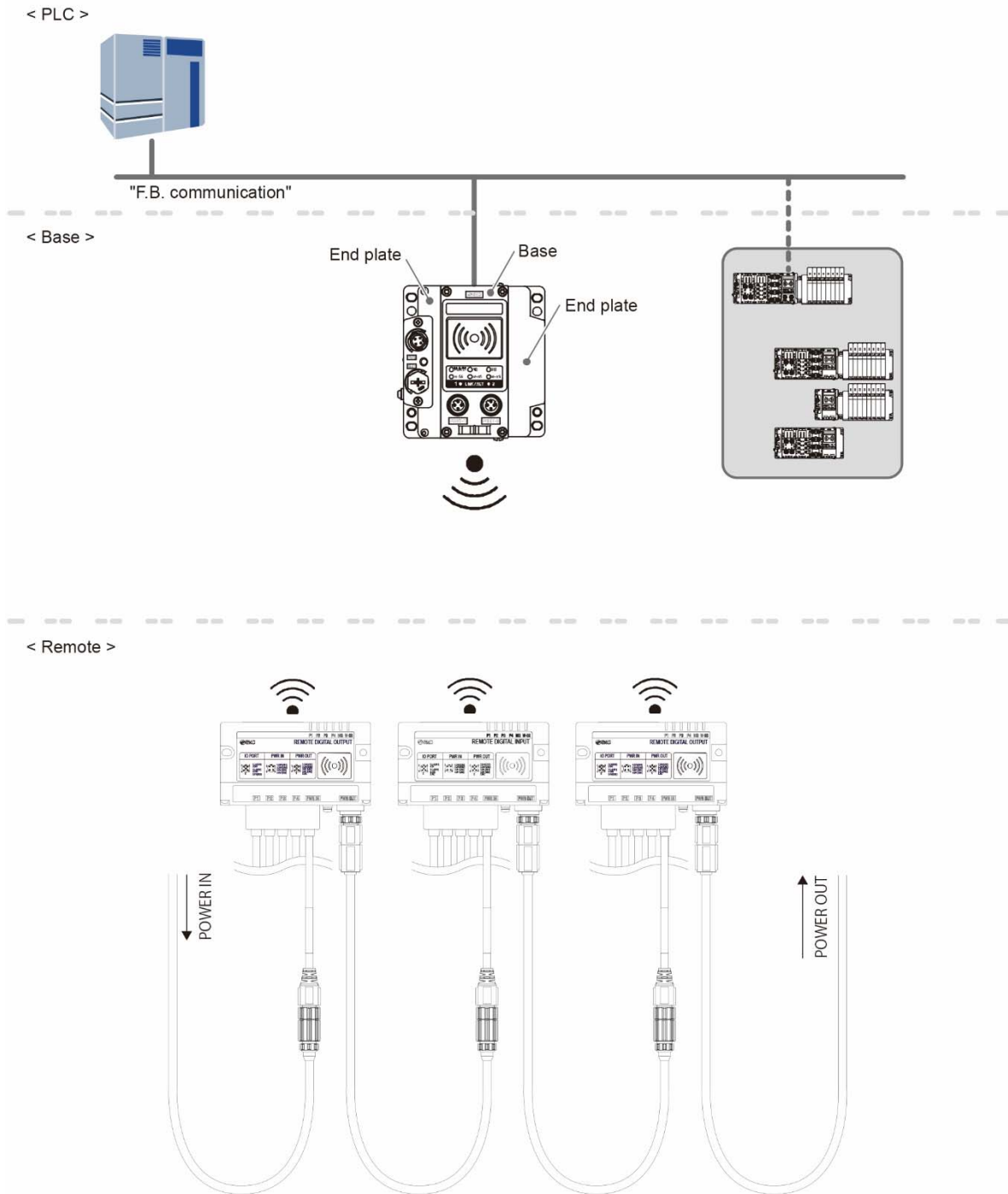

Example of Daisy Chain Connection

## IO-Link Compatibility

There are 4 I/O ports available. All 4 I/O ports are compatible with IO-Link connections. Pin 4 is assigned C/Q, and mode switching allows SIO mode compatibility.

### ■ IO-Link standard compatibility

#### ○ Data type

The EX600-WLXB1 / EX600-WLYB1 are compatible with IO-Link process data. They are not compatible with service data or event data.

IO-Link data type	Outline	Communication
Process data	Data relayed periodically (cyclic data). Applicable are measured values such as pressure, flow, etc. with sensors, valve operation signals with an SI unit, and indicated values, etc. with a power controller.	Compatible
Service data	Data relayed in response to a request and that does not pertain to process data (acyclic data). This includes device vendor name, product number, serial number, and setting parameters.	Not compatible
Event data	Data relayed when an error occurs. The nature of the data depends on the connected device. Event information such as communication errors and overloading are relayed.	Not compatible

#### ○ IO-Link functions

The following should be noted with EX600-WLXB1 / EX600-WLYB1 with regard to functions that are supported by IO-Link communication standards.

IO-Link communication function	Outline	Available
IO-Link device identification	Functionality for obtaining device identifiers such as Device ID and Vendor ID from an IO-Link device to identify connected devices.	No
Parameter download	Functionality for downloading parameters to connected IO-Link devices. Communication that requires request/response (service data) for transmission.	No

# How to Order

How to designate SMC wireless system products when ordering is shown below.

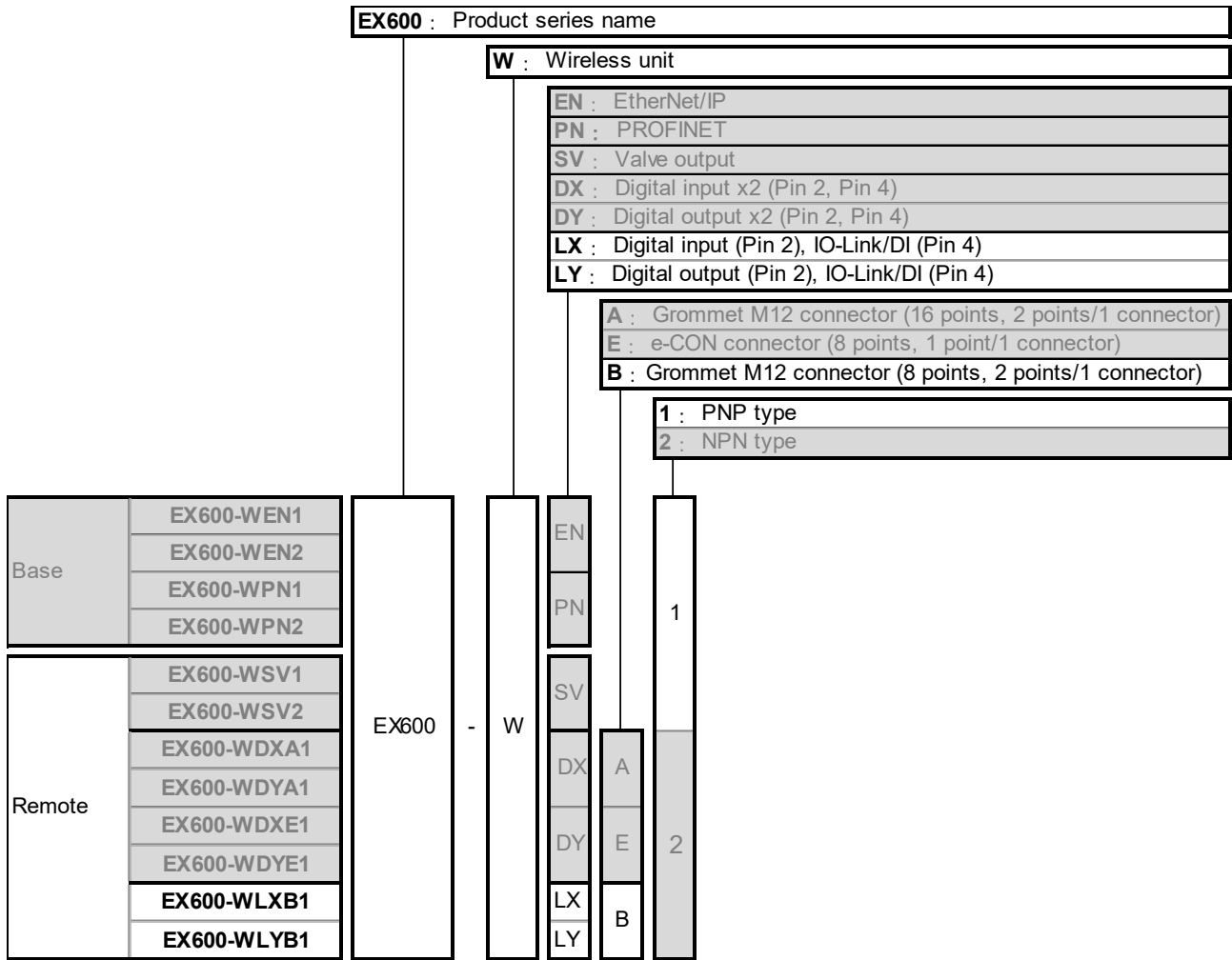

# Summary of Product Parts

## EX600-WLXB1 / EX600-WLYB1

### Appearance

Product parts on the exterior of the EX600-WLXB1 (input type) and EX600-WLYB1 (output type) do not differ and are common.

However, they differ in assignment of I/O port signal wires.

#### ○ EX600-WLXB1

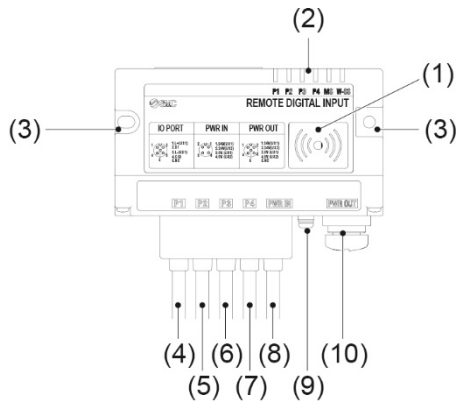

#### ○ EX600-WLYB1

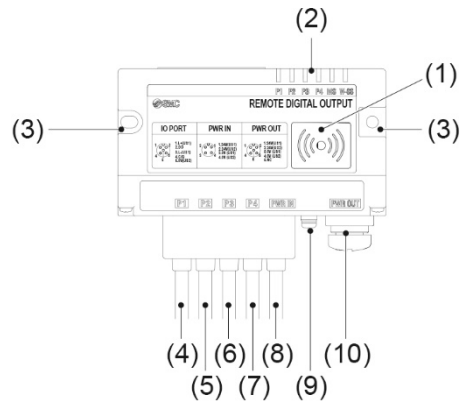

No.	Name	Application		
		EX600-WLXB1	EX600-WLYB1	
(1)	NFC antenna area	This area is intended for close contact with the NFC reader/writer. "O" is the center of the NFC antenna.		
(2)	Status LED	LED display to indicate the unit status.		
(3)	Mounting holes (M4 x 2)	For mounting the remote.		
(4)	P1	I/O port	Connect an I/O device. (Pin 2: input)	Connect an I/O device. (Pin 2: output)
(5)	P2	I/O port	Connect an I/O device. (Pin 2: input)	Connect an I/O device. (Pin 2: output)
(6)	P3	I/O port	Connect an I/O device. (Pin 2: input)	Connect an I/O device. (Pin 2: output)
(7)	P4	I/O port	Connect an I/O device. (Pin 2: input)	Connect an I/O device. (Pin 2: output)
(8)	PWR IN	Power IN port	Supplies power to the module.	
(9)	FG terminal*		To be connected to Ground. Connect to Ground for better noise immunity.	
(10)	PWR OUT	Power OUT connector	Power supply output connector. Can supply power to other modules having an M12 connector.	

\* Grounding should be as close as possible to the product and the grounding wire should be as short as possible.



## LED

### LED display

- EX600-WLXB1 / EX600-WLYB1

LED indication on the EX600-WLXB1 and EX600-WLYB1 is the same. However, the short circuit detection between each I/O port pins 2 and 5 is indicated only on the EX600-WLYB1.



LED indicators

### - LED display specifications

LED name	Function	LED status		Operation	
		Color of LED	ON or flashing		
P1 P2 P3 P4	IO-Link signal display	Green	ON	IO-Link connection active	
		Green	Flashing	IO-Link connection inactive	
	Standard IO signal display*1	Orange	ON	Digital INPUT is in the ON state	
		–	OFF	Digital INPUT is in the OFF state	
	Short circuit detection	Red	ON	Short circuit detected between pins 1 - 3	
MS	Wireless remote display	Green	ON	Wireless remote is normal	
		Green	Flashing	Restorable error is detected - Abnormal power supply voltage level for control and INPUT - Abnormal power supply voltage level for OUTPUT - Excessive I/O setting INPUTS/OUTPUTS - Short circuit detection (between pins 1 - 3)	
		Orange	Flashing (1 Hz)	Forced output mode (Indicate only, no forced output function)	
		Orange	Flashing (2 Hz)	Forced output mode (with other faults) (Indicate only, no forced output)	
		Green	Red	Alternate flashing	Wireless communication connection is configuring (Pairing)
		Red	ON	Non-restorable error is detected	
		Red	Flashing	Internal communication error	
		–	OFF	Power supply is not supplied	
W-SS	Received radio wave intensity display	Green	ON	Received power level is 3.	
		Green	Flashing (1 Hz)	Received power level is 2.	
		Green	Flashing (2 Hz)	Received power level is 1.	
		Red	Flashing	No wireless remote connected	
		–	OFF	Wireless base is not registered / No power supply	

\*1 I/O port pin 4 display for the P#. Even while in SIO mode, the status of each port's pin 2 is not displayed by the LEDs.

## Connector I/O

### ○ EX600-WLXB1 / EX600-WLYB1

- Power IN port: M12 4-pin plug (male)

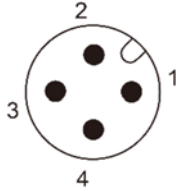

Pin no.	Signal name
1	24V (US1)
2	24V (US2)
3	0V (US1)
4	0V (US2)

Mating connector: M12 4-pin socket A code

- Power OUT connector: M12 5-pin socket (female)

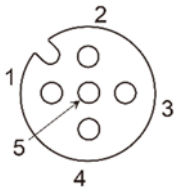

Pin no.	Signal name
1	24V (US1)
2	24V (US2)
3	0V (US1)
4	0V (US2)
5	N.C.

Mating connector: M12 4-pin plug A code, or M12 5-pin plug A code

### ○ EX600-WLXB1

- I/O port: M12 5-pin socket (female)

On EX600-WLXB1, pin 2 is assigned to digital input (DI).

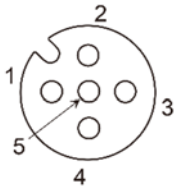

Pin no.	Signal name	Description
1	L+ (US1)	24 V (for control/input)
2	DI	Digital input (PNP)
3	L- (US1)	0 V (for control/input)
4	C/Q	IO-Link I/O
		Digital input (PNP)
	Not used	
5	N.C.	Not used

Mating connector: M12 4-pin plug A code, or M12 5-pin plug A code  
The mode can be selected for pin 4.

- Circuit diagram of EX600-WLXB1

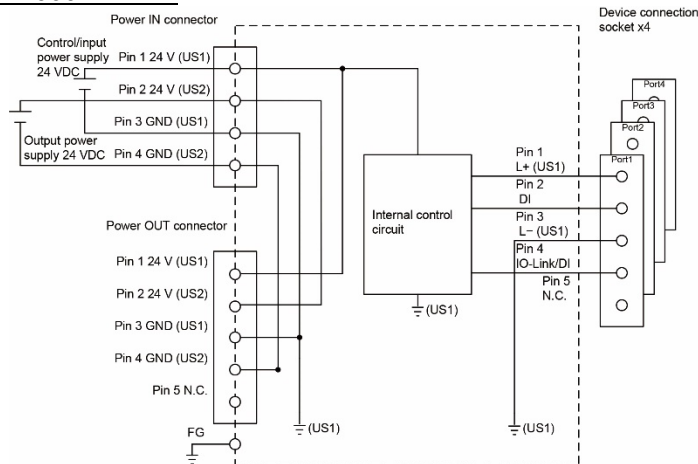

○ EX600-WLYB1

- I/O port: M12 5-pin socket (female)

On EX600-WLYB1, pin 2 is assigned to digital output (DO).

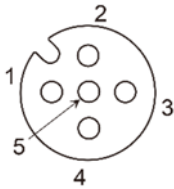

Pin no.	Signal name	Description
1	L+ (US1)	24 V (for control/input)
2	DO	Digital output (PNP)
3	L- (US1)	0 V (for control/input)
4	C/Q	IO-Link I/O
		Digital input (PNP)
		Not used
5	0V (US2)	0 V (for output)

Mating connector: M12 4-pin plug A code, or M12 5-pin plug A code  
The mode can be selected for pin 4.

- Circuit diagram of EX600-WLYB1

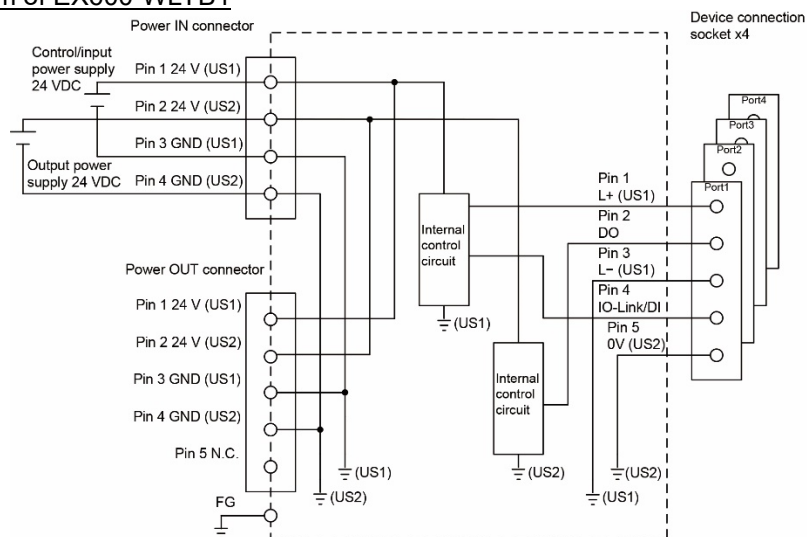

# Setting and Adjustment

## Flow Chart for Bringing the Wireless System into Operation

### ■ Flow chart for using the wireless system

How to install the SMC wireless system (base and remote) so it can be controlled by an upper level controller is described here. Grayed out items are described elsewhere. Refer to the operation manual of each product. Refer to the operation manual for each manufacturer for how to set the controller and the PLC.

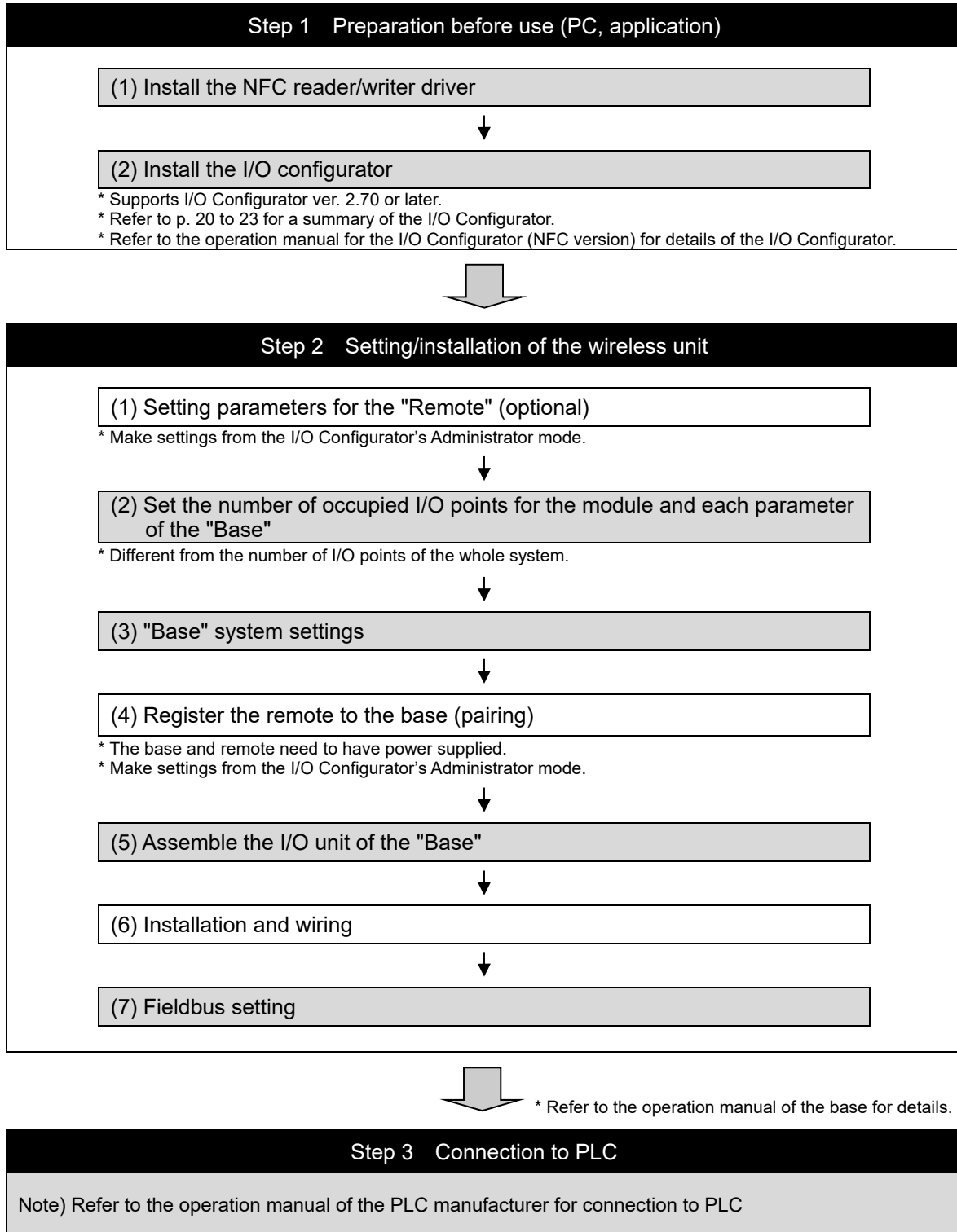

## PC Application for Managing Settings

Use I/O Configurator (NFC version) ver. 2.70 or later with the EX600-WLXB1 / EX600-WLYB1. In order to use the I/O Configurator (NFC version), it is necessary to install a driver in advance and set up the NFC reader/writer on the computer.

Refer to the operation manual for the I/O Configurator (NFC version) for details of the I/O Configurator (NFC version).

### ■ SMC wireless system I/O Configurator (NFC version)

The I/O Configurator (NFC version) can be used to check the parameter settings of the wireless unit and the details and status of the constructed wireless system, using an NFC reader/writer and a PC. There are two types of settable parameters which can be read or written **when no power is supplied to the product** and the parameters which can be read or written **only when the power is supplied to the product**.

The figure below illustrates a connected I/O Configurator (NFC version) and wireless unit.

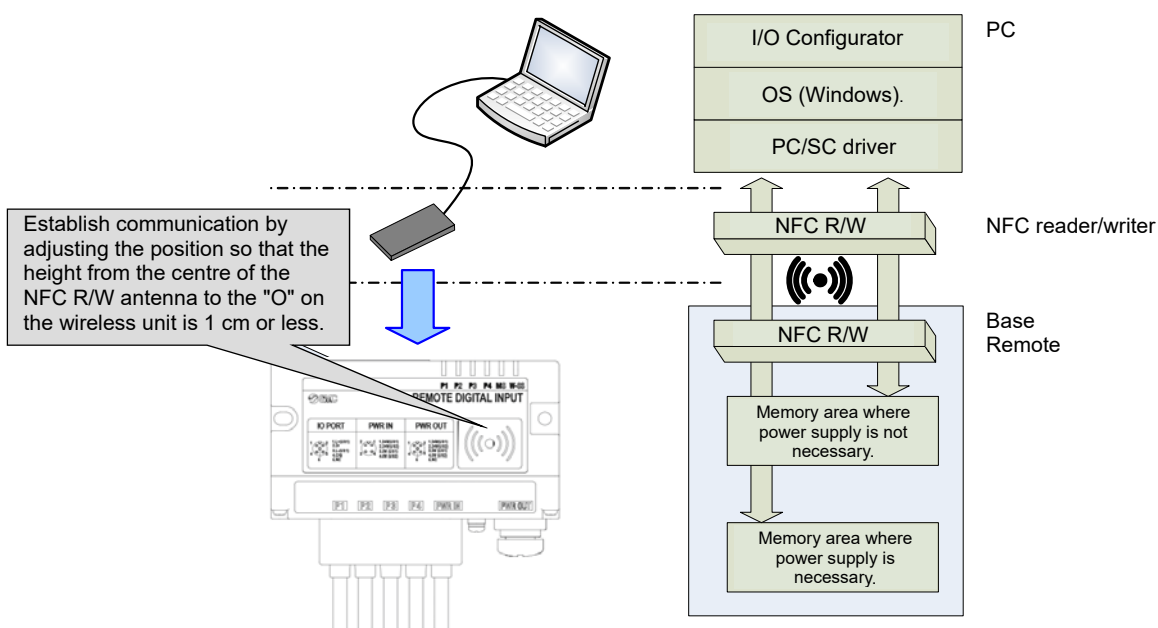

Connected I/O Configurator (NFC version) and wireless unit

In order to use the I/O Configurator (NFC version), it is necessary to install a driver etc. in advance and set up the NFC reader/writer on the computer.

Refer to the operation manual for the I/O Configurator (NFC version) for details of the I/O Configurator (NFC version).

#### \* Communication timing

The NFC communication does not occur all the time. Therefore, it is necessary to update the settings displayed on the screen by clicking the "Refresh button" to read the parameters. The changed parameters are enabled after the product is powered on or by pressing the reset button on the I/O configurator screen. As the parameter setting requires time to register, do not turn off the power supply for 2 seconds.

#### \* To change the module to be set

As the settings between the base and remote are different, it is necessary to update the displayed parameters by clicking the "Refresh button" on the screen of the I/O Configurator after changing the unit in which the parameters are to be set.

#### \* Operation already checked; NFC reader/writer

Refer to the operation manual for the I/O Configurator (NFC version).

## I/O Configurator (NFC version) screen

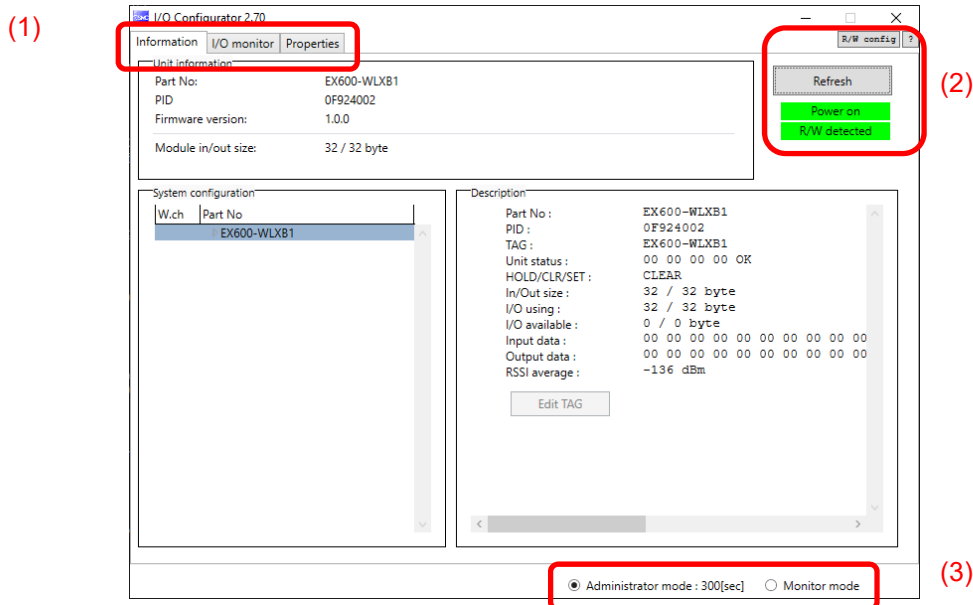

### o Function tabs (1)

The I/O Configurator (NFC version) consists of 3 function tabs.

#### [Information]

- Unit information: Indicates the wireless unit information.
- System configuration: Displays the configuration information of the base/remote (connected unit).  
The system configuration of a base unit only is shown in a tree diagram.
- Description: Shows detailed information about the unit selected in the system configuration.

#### [I/O monitor]

- Input: Shows the input map information of the wireless unit.
- Output: Shows the output map information of the wireless unit.

#### [Properties]

- Control panel: Set the parameters required to operate the base/remote.

\* Information appropriate for the model scanned by NFC is displayed. Refer to the wireless system parameter list (p. 46) for details.

### o Updated status read-in, status display, NFC reader/writer setting (2)

Used to update the configurator's displayed information, display the module's power status, and set the NFC reader/writer connection.

#### [Refresh]

- Click while holding the NFC reader/writer to the NFC antenna area to read updated information set in the wireless unit. After changing settings, they are not reflected in the I/O Configurator display until [Refresh] is clicked.

#### Power indicator

- "Power on" is displayed when power is supplied to the base/remote, and "Power off" is displayed when power is not supplied.

#### NFC reader/writer connection indicator

- When a PC is connected to the USB port and the PC detects the NFC reader/writer, "R/W detected" is displayed. When the PC cannot detect it, "R/W undetected" is displayed.

#### [R/W config] (Display depends on NFC reader/writer connected to the device)

- Click to display the NFC reader/writer setting screen.

o Mode button (3)

The I/O Configurator (NFC version) has an Administrator mode and a Monitor mode. Use Administrator mode to set parameters.

Administrator mode: Allows all parameters to be changed.

Monitor mode: Allows all parameters to be read only (for verification). Writing parameters is not available.

To enter Administrator mode, hold the NFC reader/writer to the NFC antenna area, enter the password, and click [Confirm].

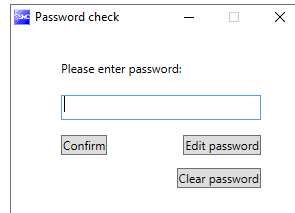

Default password: admin

If the password is forgotten, the password can be cleared. Click [Clear password] and in the [Password clear] dialog that appears, enter the master key. This clears the password. It is then possible to enter Administrator mode without a password.

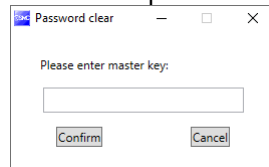

Master key: ADMIN

Set any password in Administrator mode. To prevent unauthorized use, it is recommended that the default password be changed when using the product the first time.



- When authenticating with the password, be sure to hold the NFC reader/writer to the NFC antenna area.

## ■ Monitoring and making settings

Change to Administrator mode to make settings.

Administrator mode automatically changes back to Monitor mode if there is no operation activity for 300 seconds.

The seconds of inactivity remaining are displayed to the right of "Administrator mode".

Administrator mode : 300[sec]     Monitor mode

### ○ How to perform monitoring

A description of performing monitoring is given below (in Monitor mode).

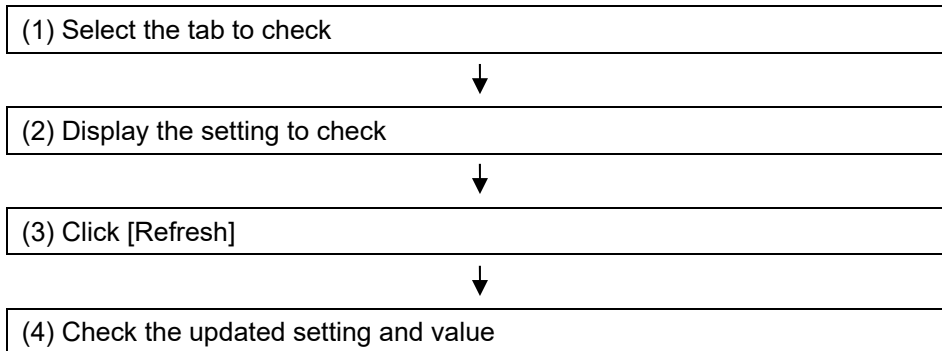

### ○ How to change settings

A description of changing settings is given below (in Administrator mode).

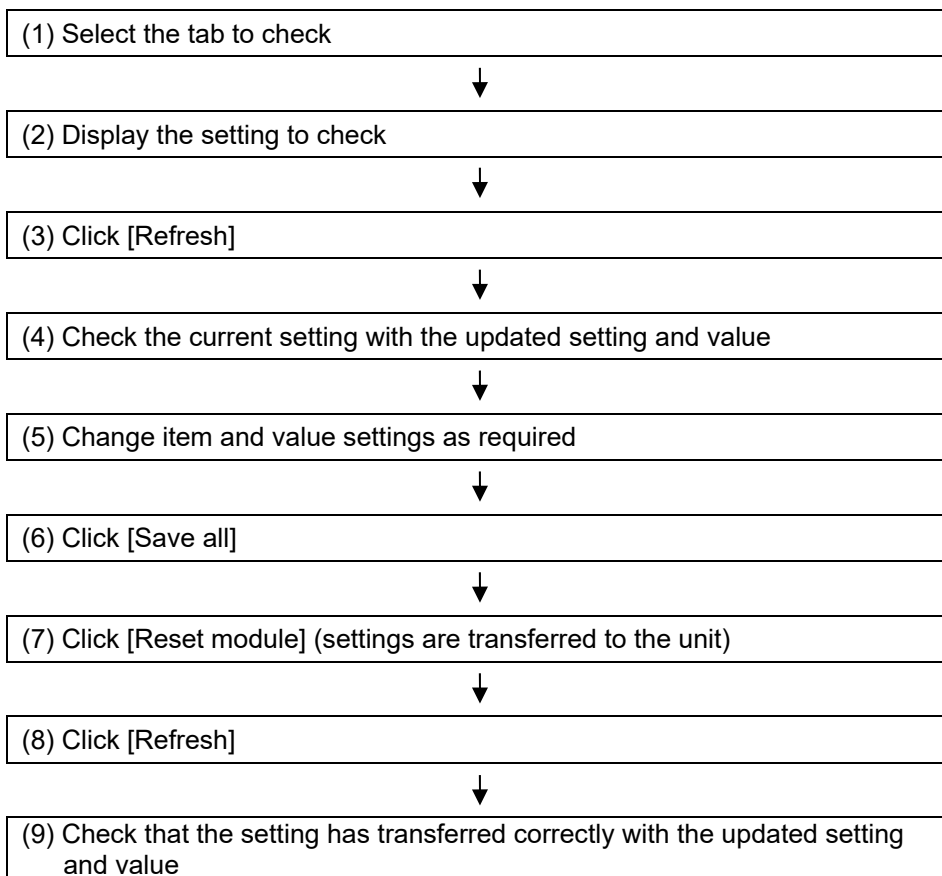



# Setting and Adjusting the Wireless Unit

## Setting Parameters for the "Remote" (Optional)

Set parameters on the EX600-WLXB1 / EX600-WLYB1 remote module.

- IO-Link Setting
- Remote setting
- Pairing setting



- The settings will be reflected any time power first reaches (or after resetting) the remote.

## IO-Link Setting

Change settings for each port (Port1, Port2, Port3, Port4) as required.

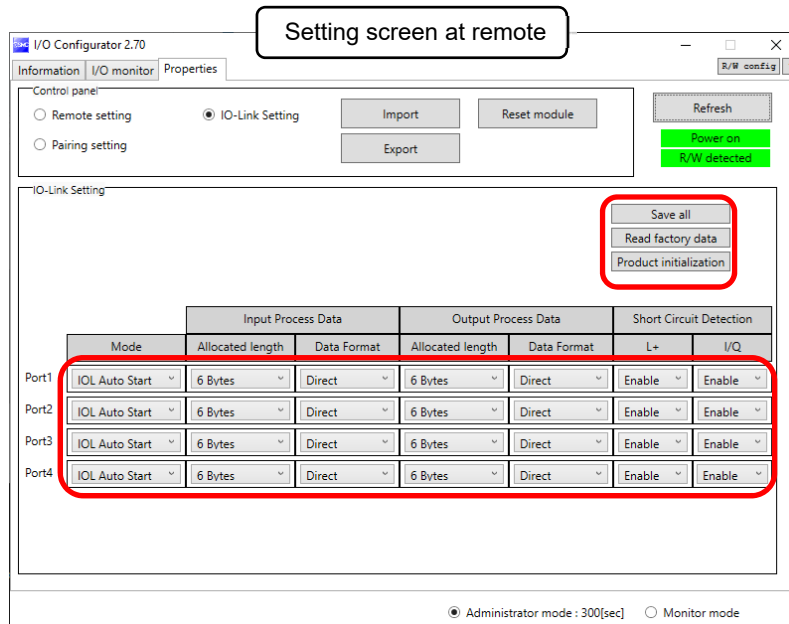

The parameters below can be set.

Parameter name	Set value	Initial value	Notes
Mode	Deactivated / IOL Auto Start / DI	IOL Auto Start	Set the operation mode of the I/O port pin 4 (C/Q for IO-Link master WLXB1 / WLYB1). Deactivated: Not used IOL Auto Start: Connect and use the IO-Link device DI: Use as SIO mode digital input
Allocated length	0 - 24 bytes (select in 1-byte units)	6 bytes	Set the data size of input process data / output process data for the IO-Link master WLXB1 / WLYB1. If the base is EX600-WEN*, the total 4-port occupied length will be a maximum 24 bytes for each of input and output. If the base is EX600-WPN*, the total 4-port occupied length will be a maximum 8 bytes for each of input and output.
Data Format	Direct / Swap 16 Bit / Swap 32 Bit / Swap All	Direct	Set the byte order of input process data / output process data for the IO-Link device.
L+	Disable / Enable	Enable	Set detection of an L+ short circuit (between I/O port pins 1 and 3). If detected, it is indicated on the LED.
I/Q	Disable / Enable	Enable	[EX600-WLYB1 only] Set detection of an I/Q short circuit (between I/O port pins 2 and 5). If detected, it is indicated on the LED.

If the base is EX600-WPN\*, change the settings so that the [Allocated length] 4-port total is a maximum 8 bytes for both of input process data and output process data.

Setting screen at remote

The screenshot shows the 'IO-Link Setting' section of the I/O Configurator 2.70. The 'IO-Link Setting' tab is active, and the 'IO-Link Setting' radio button is selected. The 'Allocated length' for both 'Input Process Data' and 'Output Process Data' is set to '2 Bytes' for all four ports (Port1, Port2, Port3, and Port4). The 'Data Format' is set to 'Direct' for all ports. The 'Short Circuit Detection' is set to 'Enable' for both 'L+' and 'I/Q' for all ports. The 'Power on' button is highlighted in green, and the 'R/W detected' indicator is also green.

Mode	Input Process Data		Output Process Data		Short Circuit Detection	
	Allocated length	Data Format	Allocated length	Data Format	L+	I/Q
Port1	2 Bytes	Direct	2 Bytes	Direct	Enable	Enable
Port2	2 Bytes	Direct	2 Bytes	Direct	Enable	Enable
Port3	2 Bytes	Direct	2 Bytes	Direct	Enable	Enable
Port4	2 Bytes	Direct	2 Bytes	Direct	Enable	Enable

● Administrator mode : 300[sec] ○ Monitor mode

## Remote setting

Make any remote settings as required.

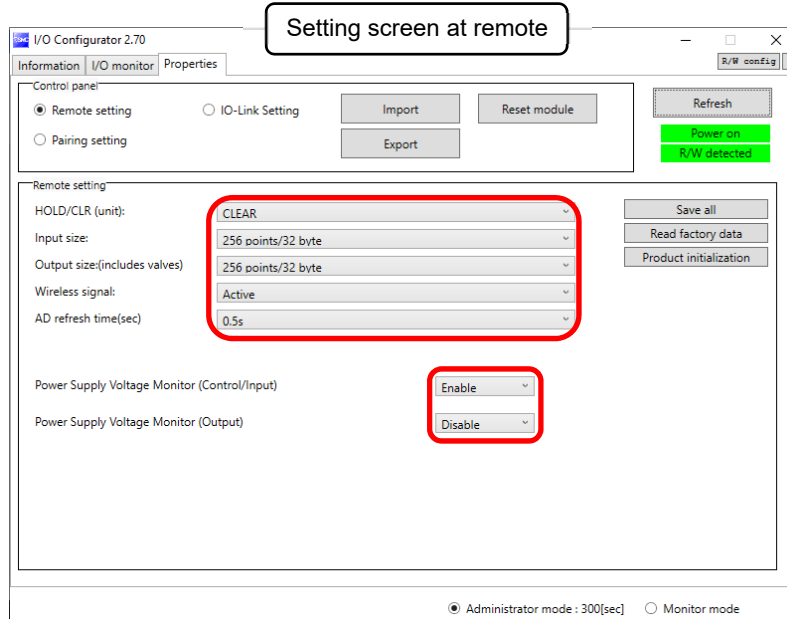

The parameters below can be set.

Parameter name	Set value	Initial value	Notes
HOLD/CLR (unit)	CLEAR / HOLD	CLEAR	Set how all outputs operate when fieldbus communication is disconnected. CLEAR: Clear the output (reset to initial state when communication is disconnected) HOLD: Hold the output at the current value (maintain at value when communication was disconnected)
Input size	64 points/8 byte to 256 points/32 byte (select in 16-point/2-byte units)	256 points/32 byte	Set the number of occupied points for the remote module input. If the base is EX600-WEN*, the number of occupied points for the module input will be a maximum 256 points/32 bytes. If the base is EX600-WPN*, the number of occupied points for the module input will be a maximum 128 points/16 bytes.
Output size (includes values)	64 points/8 byte to 256 points/32 byte (select in 16-point/2-byte units)	256 points/32 byte	Set the number of occupied points for the remote module output. If the base is EX600-WEN*, the number of occupied points for the module output will be a maximum 256 points/32 bytes. If the base is EX600-WPN*, the number of occupied points for the module output will be a maximum 128 points/16 bytes.
Wireless signal	Active / Idle	Active	Activate/deactivate wireless communication for the remote. If set to "Idle", the remote does not engage in wireless communication.
AD refresh time (sec)	0.1s / 0.2s / 0.5s / 1s / 2s / 5s / 10s / 30s / 60s	0.5s	Set the interval in seconds for data updates of the connected analog input unit.
Power Supply Voltage Monitor (Control/Input)	Disable / Enable	Enable	Set detection of drops in voltage supplied to L+/L- (between I/O port pins 1 and 3). If detected, it is indicated on the LED.
Power Supply Voltage Monitor (Output)	Disable / Enable	Disable	EX600-WLYB1 only. Set detection of drops in voltage supplied to DO/0V (between I/O port pins 2 and 5). If detected, it is indicated on the LED.

If the base is EX600-WPN\*, the I/O process data size of the module is 16 bytes/16 bytes; set both [Input size] and [Output size (includes values)] so that their setting is [128 points/16 byte] or less.

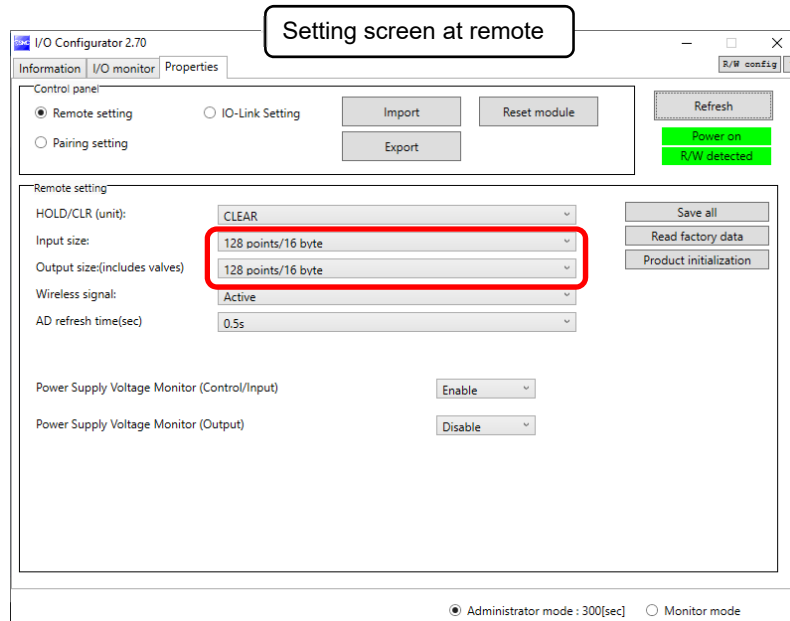

## ■ Pairing setting

### Registering a remote to a base (pairing)

Register a remote to a base to allow wireless communication between the base and remote. Pair the base and remote after switching both modules to [Pairing mode]. On the remote, only shifting to pairing mode is required. On the base, registering the remote module to be paired completes pairing between both modules.

#### ○ How to pair

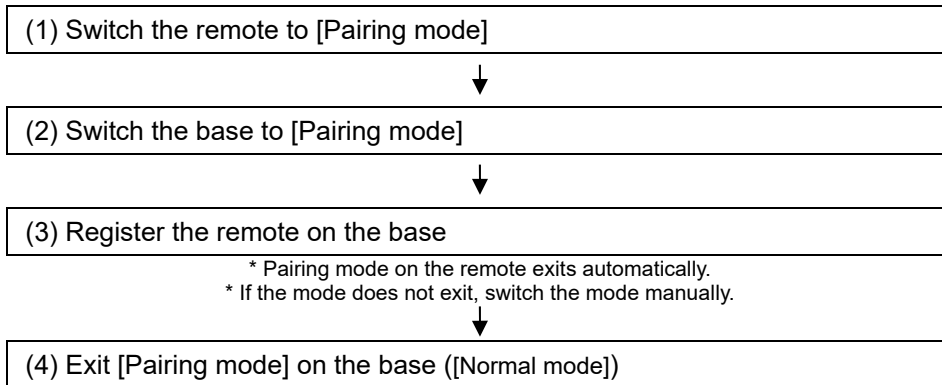

#### ○ Pairing mode

After changing the operation mode with the pairing setting, click the [Reset module] button to reset and change the mode, and the module then waits to be registered or to connect to the base. Turning power back on will also reset.

\* Once in pairing mode, the MS LED flashes alternately in green and red. After changing the mode with the pairing setting, be sure to check.

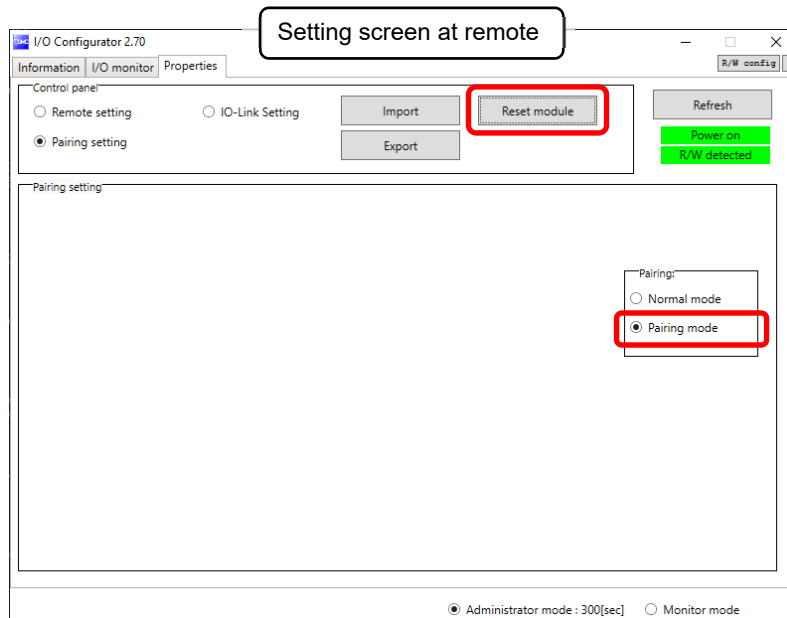

o Establishing a [base-remote] module pair

Register a remote to a base to allow wireless communication between a base and remote with a fixed pair. This registers each PID (Product ID) of the base and remote to each other, and establishes communication free from other-network interference. Perform the setting below with the NFC reader/writer held up to the base.

**!**

- After changing the operation mode with the pairing setting, click [Reset module] to reset or turn the power back on to change the mode, and the module then waits to be registered or to connect to the remote.

(1) Shift to pairing mode (make setting on base module)

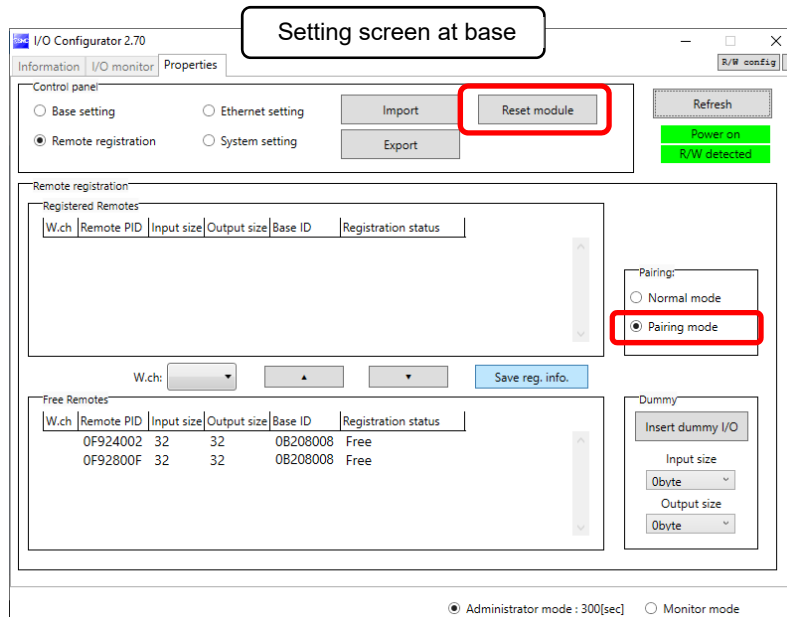

(2) Register the remote (make setting on base module)

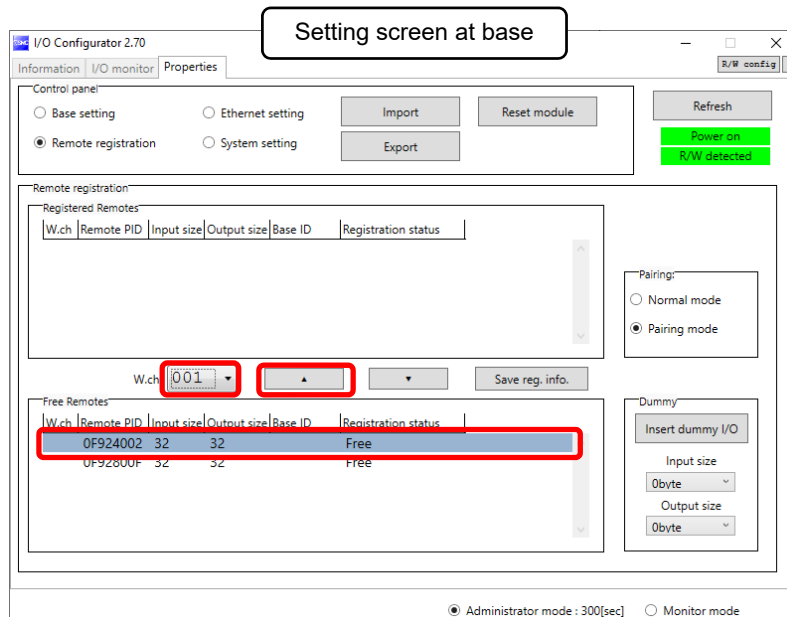

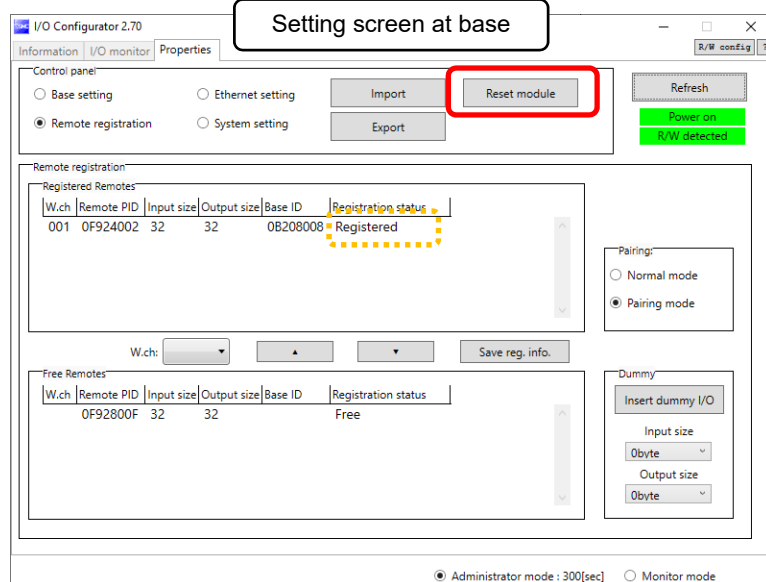
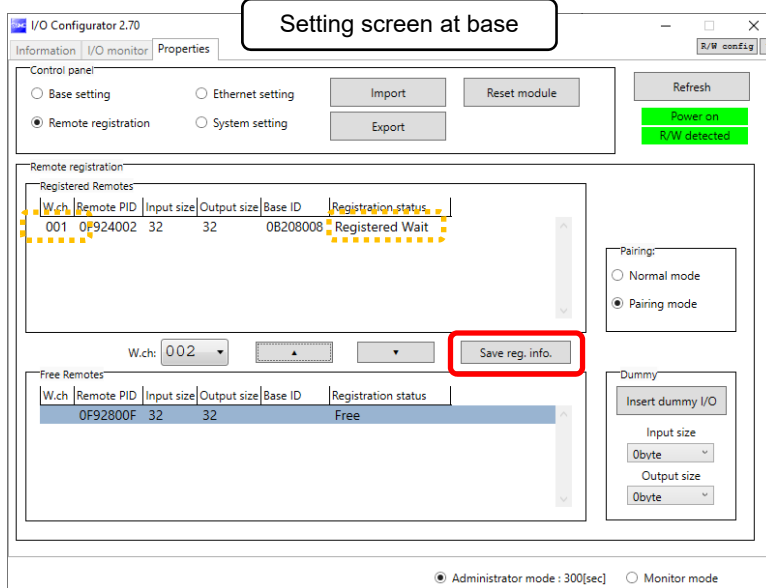

- Example of 2 remote modules registered to CH1 and CH2 shown below



Register a dummy remote as necessary.

# Mounting and Installing a Unit

## EX600-WLXB1 / EX600-WLYB1

### Installation

#### - Direct mounting

Mount the unit with M4 screws (not included) using the two mounting holes. (Tightening torque: 1.35 to 1.65 Nm)

Connect to Ground using the FG terminal.

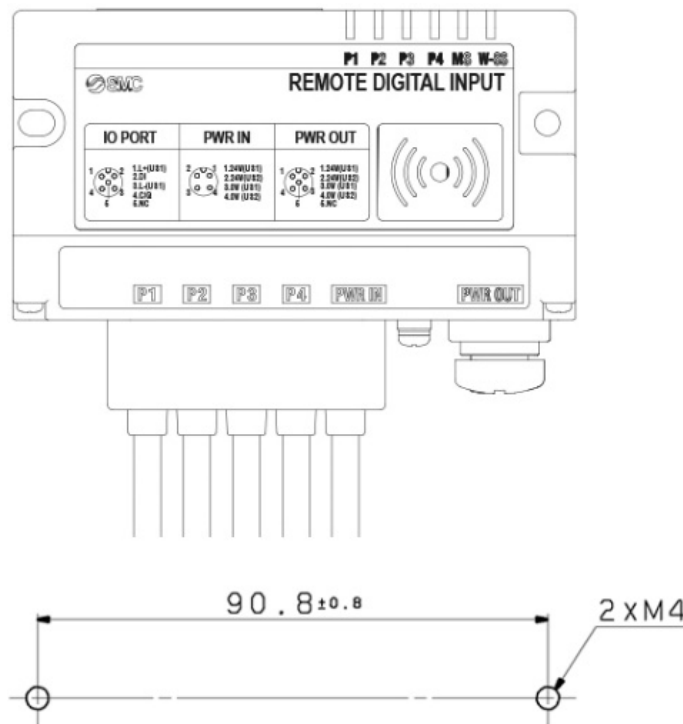

Recommended mounting hole dimensions



# Troubleshooting

When problems occur, take appropriate countermeasures after checking the LED indication, troubleshooting, and parameter settings.

If the possible cause cannot be identified, the equipment may be malfunctioning.

A fieldbus system failure can be caused by the operating environment. Contact SMC to discuss the issue.

## EX600-WLXB1 / EX600-WLYB1 troubleshooting items

LED	Description	LED status		Problem no.	
		Color of LED	ON or flashing		
–	ALL LEDs are OFF	–	–	See problem no. 1	
P1 P2 P3 P4	P1, P2, P3, or P4 any status other than green LED ON	Green	Flashing	See problem no. 2	
		Orange	ON		
		Red	ON		
		–	OFF		
MS	MS any status other than green LED ON	Green	Flashing	See problem no. 3	
		Orange	Flashing (1 Hz)		
		Orange	Flashing (2 Hz)		
		Green	Red		Alternate flashing
		Red	ON		
		Red	Flashing		
		–	OFF		
W-SS	W-SS any status other than green LED ON	Green	Flashing (1 Hz)	See problem no. 4	
		Green	Flashing (2 Hz)		
		Red	Flashing		
		–	OFF		
Digital input/output device does not operate correctly				See problem no. 5	
IO-Link device does not function correctly.				See problem no. 6	
NFC-related				See problem no. 7	

EX600-WLXB1 / EX600-WLYB1 troubleshooting

Problem no.	LED name	LED status		Possible causes	Inspection and countermeasures
		Color of LED	ON or flashing		
1	–	No LEDs are ON		Control power supply OFF (W-SS only: wireless base is not registered / no power supply)	Supply 24 VDC +/-10% for control power.
2	P1, P2, P3, P4	Green	Flashing	IO-Link communication failure IO-Link device disconnected	Check port status information and do the following. Check the IO-Link device wiring. Check the IO-Link device power supply. Replace the IO-Link device if faulty.
		Red	ON	Short circuit with control/input power voltage (between pins 1 and 3)	Check port status information, and check the IO-Link device wiring.
		–	OFF	SIO (DI) device connection failure	Check the digital input device wiring. Replace the digital input device if faulty.

Problem no.	LED name	LED status		Possible causes	Inspection and countermeasures	
		Color of LED	ON or flashing			
3	MS	Green		Flashing	<ul style="list-style-type: none"> <li>- Control/input power supply voltage drop</li> <li>- Output power supply voltage drop</li> <li>- Excessive I/O setting inputs/outputs</li> <li>- Short circuit between I/O port pins 1 and 3</li> <li>- [EX600-WLYB1 only] Short circuit between I/O port pins 2 and 5</li> </ul>	<p>On base, check port diagnostic information or I/O Configurator information tab and do the following.</p> <p>Supply 24 VDC +/-10% for control power. On EX600-WLYB1, supply 24 VDC +/-10% for output power.</p> <p>Initialize the remote, re-check the occupied points set, and repair.</p> <p>Check the wiring at ports which have a red LED ON.</p> <p>Check the wiring of the output device.</p>
		Orange		Flashing (1 Hz)	Forced output mode	Data output not available with this product. Exit the forced output mode.
		Orange		Flashing (2 Hz)	Error corresponding to forced output mode and MS LED flashing green	Data output not available with this product. Exit the forced output mode. After exiting the forced output mode, check the possible causes and countermeasures given for a flashing green MS LED indication.
		Green	Red	Alternate flashing	Pairing mode	The system has been set to [Pairing mode]. If not performing pairing, change to [Normal mode]. Check the registration of the base.
		Red		ON	Unrecoverable error is detected	The remote is malfunctioning. Replace the remote. If the error persists after replacement, stop using the equipment and contact your SMC sales representative.
		Red		Flashing	Internal communication error	The remote is malfunctioning. Replace the remote. If the error persists after replacement, stop using the equipment and contact your SMC sales representative.
		-		OFF	Power supply for control is OFF	Supply 24 VDC +/-10% for control power.

Problem no.	LED name	LED status		Possible causes	Inspection and countermeasures
		Color of LED	ON or flashing		
4	W-SS	Green	Flashing (1 Hz)	Received radio wave failure	If the cause of a device problem cannot be determined and device operation is unstable or a problem is not constant, reception from the base module may be weak. Adjust the location where the module is installed, or remove any items that may be blocking radio waves.
		Green	Flashing (2 Hz)	Received radio wave failure	If the cause of a device problem cannot be determined and device operation is unstable or a problem is not constant, reception from the base module may be weak. Adjust the location where the module is installed, or remove any items that may be blocking radio waves.
		Red	Flashing	Wireless communication is not connected	Check that power is shared with the base. Check the registration of the base. Check the module pairing and if necessary re-pair the modules.
		—	OFF	Wireless base not registered  Power is not supplied	On the base, check the registration of the remote and perform pairing correctly.  Check that 24 VDC +/-10% is supplied to the remote for control/input (US1).

Problem no.	Problem	Possible causes	Inspection and countermeasures
5	Abnormal digital input device operation	Input type does not match	If the polarities (PNP, NPN) of the remote and digital input device do not match, replace one of them to make a matching combination.
		Control/input power supply voltage drop	Check that 24 VDC $\pm$ 10% is supplied to the remote for control.
		Wiring or connection failure	Connect the wiring between the remote and the digital input device correctly.
		Remote malfunction	Replace the remote and check operation.
		Digital input device malfunction	Replace the digital input device and check operation. Or, refer to troubleshooting for the digital input device.
	Abnormal digital output device operation	Mismatched output type	If the polarities (PNP, NPN) of the remote and digital output device do not match, replace one of them to make a matching combination.
		Output power supply voltage drop	Check that the remote's MS LED is green. If it is not lit or flashing green, supply 24 VDC $\pm$ 10% for output power supply.
		Wiring or connection failure	Connect the wiring between the remote and the digital output device correctly.
		Remote malfunction	Replace the remote and check operation.
		Digital output device malfunction	Replace the digital output device and check operation. Or, refer to troubleshooting for the digital output device.
		Fieldbus error	Check the fieldbus settings or ladder program.

Problem no.	Problem	Possible causes	Inspection and countermeasures
6	IO-Link device operation error*1	Power supply for control and input is abnormal.	Check that the remote's MS LED is green. If other than ON green, supply 24 VDC +/-10% for control/input power.
		Abnormal power supply for output	Refer to "Example of Output Device Connection". With WLXB1, use a Y junction connector to supply output power to the IO-Link device. Check that the WLYB1 MS LED is green. If other than ON green, supply 24 VDC +/-10% for output power. Also check the fieldbus program.
		Wiring or connection failure	Connect wiring between the remote I/O port and the IO-Link device correctly.
		Mistaken I/O port mode setting	If the P1, P2, P3, or P4 LED is orange, the port is in SIO mode. If an IO-Link device is connected, check the mode setting of each port.
		Remote malfunction	Replace the remote and check operation.
		IO-Link device malfunction	Replace the IO-Link device and check operation. Or, refer to the troubleshooting of the IO-Link device used.
		Fieldbus error	Check the fieldbus settings or ladder program.
7	NFC communication error	NFC communication is not established (communication failure)	Check the following items and check operation again. <ul style="list-style-type: none"> <li>- Check that the NFC port settings on the PC are correct.</li> <li>- Check that the specifications of the NFC reader/writer being used are appropriate.</li> <li>- Check that the NFC reader/writer is connected correctly.</li> <li>- Out of range for NFC communication. Place closer (less distance between NFC antenna area and NFC reader/writer).</li> </ul>
		NFC reader/writer malfunction	Replace the NFC reader/writer and check operation. If the error persists after replacement, stop using the equipment and contact your SMC sales representative.

\*1 Also check port status in the IO-Link device analysis. Refer to "Port status area bit assignment" (p. 40) for details.

# Technical Information

## EX600-WL\*B1 (Compact Wireless Remote Unit for IO-Link) I/O Map

■ When connected to EtherNet/IP™ wireless base

An I/O map for when the base is EX600-WEN\* is given below.

Initial parameters on the EX600-WLXB1 / EX600-WLYB1 are as per this I/O map.

Fixed length portion 8 bytes + 24 bytes (variable length 6 bytes × 4 ports)

○ EX600-WLXB1 (PIN 2 input type)

	Input (Process data size 8 to 32 bytes)								Output (Process data size 8 to 32 bytes)							
	Bit 7	Bit 6	Bit 5	Bit 4	Bit 3	Bit 2	Bit 1	Bit 0	Bit 7	Bit 6	Bit 5	Bit 4	Bit 3	Bit 2	Bit 1	Bit 0
Byte 0	Port 4		Port 3		Port 2		Port 1		_*							
Byte 1	X2**	X4**	X2**	X4**	X2**	X4**	X2**	X4**								
Byte 2	Fixed value: 0															
Byte 3	Fixed value: 0															
Byte 4	Port 1 status															
Byte 5	Port 2 status															
Byte 6	Port 3 status															
Byte 7	Port 4 status															
Byte 8	Port 1 input process data								Port 1 output process data							
to	Port 2 input process data								Port 2 output process data							
	Port 3 input process data								Port 3 output process data							
	Port 4 input process data								Port 4 output process data							
Byte 31	Port 1 to Port 4 total is maximum 24 bytes (Maximum 0 to 24 bytes, dependent on [Input size] setting)								Port 1 to Port 4 total is maximum 24 bytes (Maximum 0 to 24 bytes, dependent on [Output size (includes values)] setting)							

\* "-" indicates reserved. A reserved value does not affect module operation.

\*\* "X" indicates input, value indicates I/O port pin number.

○ EX600-WLYB1 (PIN 2 output type)

	Input (Process data size 8 to 32 bytes)								Output (Process data size 8 to 32 bytes)															
	Bit 7	Bit 6	Bit 5	Bit 4	Bit 3	Bit 2	Bit 1	Bit 0	Bit 7	Bit 6	Bit 5	Bit 4	Bit 3	Bit 2	Bit 1	Bit 0								
Byte 0	Port 4		Port 3		Port 2		Port 1		Port 4		Port 3		Port 2		Port 1									
Byte 1	0	X4**	0	X4**	0	X4**	0	X4**	Y2**	-*	Y2**	-*	Y2**	-*	Y2**	-*								
Byte 2	Fixed value: 0								_*															
Byte 3	Fixed value: 0																							
Byte 4	Port 1 status																							
Byte 5	Port 2 status																							
Byte 6	Port 3 status																							
Byte 7	Port 4 status																							
Byte 8	Port 1 input process data																Port 1 output process data							
to	Port 2 input process data																Port 2 output process data							
	Port 3 input process data								Port 3 output process data															
	Port 4 input process data								Port 4 output process data															
Byte 31	Port 1 to Port 4 total is maximum 24 bytes (Maximum 0 to 24 bytes, dependent on [Input size] setting)								Port 1 to Port 4 total is maximum 24 bytes (Maximum 0 to 24 bytes, dependent on [Output size (includes values)] setting)															

\* "-" indicates reserved. A reserved value does not affect module operation.

\*\* "X" indicates input, "Y" indicates output, value indicates I/O port pin number.

## ■ When connected to PROFINET wireless base

If the base is EX600-WPN\*, the maximum I/O process data size for an IO-Link master WLXB1 / WLYB1 unit assigned to a wireless channel will be 16/16 bytes, as required by product specifications. Module I/O process data size for the EX600-WLXB1 / EX600-WLYB1 module has an upper limit of 16/16 bytes (128/128 points). Process data that can be assigned to each port is from Byte 8 to 15 (process data settable range: 0 to 8 bytes).

### ○ EX600-WLXB1 (PIN 2 input type)

	Input (Process data size 8 to 16 bytes)								Output (Process data size 8 to 16 bytes)							
	Bit 7	Bit 6	Bit 5	Bit 4	Bit 3	Bit 2	Bit 1	Bit 0	Bit 7	Bit 6	Bit 5	Bit 4	Bit 3	Bit 2	Bit 1	Bit 0
Byte 0	Port 4		Port 3		Port 2		Port 1		_*							
Byte 1	X2**	X4**	X2**	X4**	X2**	X4**	X2**	X4**								
Byte 2	Fixed value: 0															
Byte 3	Fixed value: 0															
Byte 4	Port 1 status															
Byte 5	Port 2 status															
Byte 6	Port 3 status															
Byte 7	Port 4 status															
Byte 8 to Byte 15	Port 1 input process data Port 2 input process data Port 3 input process data Port 4 input process data Port 1 to Port 4 total is maximum 8 bytes (Maximum 0 to 8 bytes, dependent on [Input size] setting)								Port 1 output process data Port 2 output process data Port 3 output process data Port 4 output process data Port 1 to Port 4 total is maximum 8 bytes (Maximum 0 to 8 bytes, dependent on [Output size (includes values)] setting)							

\* "\_" indicates reserved. A reserved value does not affect module operation.

\*\* "X" indicates input, value indicates I/O port pin number.

### ○ EX600-WLYB1 (PIN 2 output type)

	Input (Process data size 8 to 16 bytes)								Output (Process data size 8 to 16 bytes)							
	Bit 7	Bit 6	Bit 5	Bit 4	Bit 3	Bit 2	Bit 1	Bit 0	Bit 7	Bit 6	Bit 5	Bit 4	Bit 3	Bit 2	Bit 1	Bit 0
Byte 0	Port 4		Port 3		Port 2		Port 1		Port 4		Port 3		Port 2		Port 1	
Byte 1	0	X4**	0	X4**	0	X4**	0	X4**	Y2**	_*	Y2**	_*	Y2**	_*	Y2**	_*
Byte 2	Fixed value: 0								_*							
Byte 3	Fixed value: 0															
Byte 4	Port 1 status															
Byte 5	Port 2 status															
Byte 6	Port 3 status								_*							
Byte 7	Port 4 status															
Byte 8 to Byte 15	Port 1 input process data Port 2 input process data Port 3 input process data Port 4 input process data Port 1 to Port 4 total is maximum 8 bytes (Maximum 0 to 8 bytes, dependent on [Input size] setting)								Port 1 output process data Port 2 output process data Port 3 output process data Port 4 output process data Port 1 to Port 4 total is maximum 8 bytes (Maximum 0 to 8 bytes, dependent on [Output size (includes values)] setting)							

\* "\_" indicates reserved. A reserved value does not affect module operation.

\*\* "X" indicates input, "Y" indicates output, value indicates I/O port pin number.



## ■ Port status area bit assignment

Each port's status is assigned a bit in the 4 bytes from the 4th to 7th bytes from the head, at the I/O map input. 1 byte (8 bits) per 1 port, and a bit flag map is shown below.

Port (1 to 4)							
Bit 7	Bit 6	Bit 5	Bit 4	Bit 3	Bit 2	Bit 1	Bit 0
PQ	Dev-Err	Dev-COM	Reserved	Reserved	Pwr-Short	PDsize-Mismatch	Reserved

Bit	Name	Description	Value	LED
7	PQ	Input process data enabled/disabled	0: Enabled 1: Disabled	None
6	Dev-Err	Event	0: No Event 1: Error	None
5	Dev-COM	Port communication	0: Device not connected 1: Device connected	0: P#* Flashing green 1: P#* ON green
4	Reserved	–	0	–
3	Reserved	–	0	–
2	Pwr-Short	L+ short circuit or I/Q short circuit	0: No short circuit 1: Short circuited	1: MS flashing green (L+ (between pins 1 and 3) short circuit: P#* ON red)
1	PDsize-Mismatch	Process data size error	0: Set size or less (normal) 1: Exceeded size (error) **	None
0	Reserved	–	0	–

\* P# indicates either P1, P2, P3, or P4.

\*\* An error is detected when the process data size of the actually connected device exceeds the size which is set with "Allocated length".

## ■ IO-Link port I/O data byte order

The byte order of input process data / output process data for the IO-Link device can be set per port. Settable parameters are shown below.

Setting	Description	Initial value
Direct	Data order does not change	○
Swap 16 Bit	Swap bytes in word units	—
Swap 32 Bit	Swap bytes in double word units	—
Swap All	Swap all bytes	—

### Port setting (data format)

Example) Process data byte swap (process data size: 8 bytes)

Setting	Byte 0	Byte 1	Byte 2	Byte 3	Byte 4	Byte 5	Byte 6	Byte 7
Original data	01	23	45	67	89	AB	CD	EF
Direct	01	23	45	67	89	AB	CD	EF
Swap 16 Bit	23	01	67	45	AB	89	EF	CD
Swap 32 Bit	67	45	23	01	EF	CD	AB	89
Swap All	EF	CD	AB	89	67	45	23	01

Example) Process data byte swap (process data size: 7 bytes)

Setting	Byte 0	Byte 1	Byte 2	Byte 3	Byte 4	Byte 5	Byte 6	Byte 7
Original data	01	23	45	67	89	AB	CD	—
Direct	01	23	45	67	89	AB	CD	—
Swap 16 Bit	23	01	67	45	AB	89	CD	—
Swap 32 Bit	67	45	23	01	89	AB	CD	—
Swap All	CD	AB	89	67	45	23	01	—

\* When Swap 16 Bit or Swap 32 Bit are set, byte order swapping is not performed for portions of data which do not satisfy the unit of order change.

# SMC Wireless System I/O Map Configuration

## Example of an SMC wireless system I/O map

An I/O map of an SMC wireless system having an EX600-WEN base module, EX600-WLXB1 remote (1 unit), and EX600-WLYB1 remote (1 unit) is given below. EX600-WLXB1 connects to wireless channel 1 on a base module with each I/O port process data size at 6 bytes (total 24 bytes). The example shows EX600-WLYB1 connecting to wireless channel 2 on a base module with each I/O port process data size at 2 bytes (total 8 bytes).

**Base (EX600-WEN) setting**

- Input size : 0Byte
- Out size : 0Byte
- IO mapping : AUTO
- Diagnostic setting: details
- Remotes registerable: 15



**Remote (EX600-WLXB1) setting**

Input size : 32bytes  
Out size : 32bytes

PORT1~PORT4

Port mode : IOL Auto Start  
(All for IO-LINK)

Allocated length : 6bytes

Data Format : Direct

Wireless Ch. 1



**Remote (EX600-WLYB1) setting**

Input size : 16bytes  
Out size : 16bytes

PORT1~PORT4

Port mode : IOL Auto Start  
(All for IO-LINK)

Allocated length : 2bytes

Data Format : Direct

Wireless Ch. 2



Address	Input Data		Output Data					
	Unit name	Content	Unit name	Content				
0	Base	System Diagnosis1	Reserved	Reserved				
1		System Diagnosis2						
2		System Diagnosis3						
3		System Diagnosis4						
4		Remote connection information						
5		Remote connection information						
6		Remote diagnostic information						
7		Remote diagnostic information						
8		Remote registration information						
9		Remote registration information						
10	IO-Link Master Wireless Ch1	SIO	IO-Link Master Wireless Ch1	PORT1 IO-Link Process Data				
11		Reserved(ALL 0)		PORT1 Status	PORT2 IO-Link Process Data			
12						PORT2 Status		
13							PORT3 Status	
14								PORT4 Status
15								
16		PORT2 IO-Link Process Data						
17				PORT3 IO-Link Process Data				
18		PORT4 IO-Link Process Data						
19				SIO				
20	Reserved							
21		PORT1 IO-Link Process Data						
22	PORT2 IO-Link Process Data							
23		PORT3 IO-Link Process Data						
24	PORT4 IO-Link Process Data							
25		SIO						
26	Reserved							
27		PORT1 IO-Link Process Data						
28	PORT2 IO-Link Process Data							
29		PORT3 IO-Link Process Data						
30	PORT4 IO-Link Process Data							
31		SIO						
32	Reserved							
33		PORT1 IO-Link Process Data						
34	PORT2 IO-Link Process Data							
35		PORT3 IO-Link Process Data						
36	PORT4 IO-Link Process Data							
37		SIO						
38	Reserved							
39		PORT1 IO-Link Process Data						
40	PORT2 IO-Link Process Data							
41		PORT3 IO-Link Process Data						
42	PORT4 IO-Link Process Data							
43		SIO						
44	Reserved(ALL 0)							
45		PORT1 Status						
46	PORT2 Status							
47		PORT3 Status						
48	PORT4 Status							
49		PORT1 IO-Link Process Data						
50	PORT2 IO-Link Process Data							
51		PORT3 IO-Link Process Data						
52	PORT4 IO-Link Process Data							
53		SIO						
54	Reserved							
55		PORT1 IO-Link Process Data						
56	PORT2 IO-Link Process Data							
57		PORT3 IO-Link Process Data						
	PORT4 IO-Link Process Data							

Total INPUT size: 58 bytes      Total OUTPUT size: 48 bytes

## Short Circuit Detection

Diagnostic function which detects the generation of an overcurrent due to a short circuit between the WLXB1 / WLYB1 L+ and I/Q.

Detection of a short circuit between the WLXB1 / WLYB1 L+ and I/Q can be set for individual ports.

I/Q short circuit detection is available for EX600-WLYB1 only.

### L+ short circuit detection

Detect short circuit between pins 1 and 3 of I/O port.

Settable parameters for L+ short circuit detection are shown below.

Parameter	Description	Initial value
Disable	Disables L+ short circuit detection. Does not reflect L+ status in diagnostic information or LED indication.	–
Enable	Enables L+ short circuit detection. Reflects L+ status in diagnostic information or LED indication.	Initial value

### I/Q short circuit detection

Detect short circuit between pins 2 and 5 of I/O port. This function can be enabled on EX600-WLYB1 (pin 2 is assigned to digital output).

Settable parameters for I/Q short circuit detection are shown below.

Parameter	Description	Initial value
Disable	Disables I/Q short circuit detection. Does not reflect I/Q status in diagnostic information or LED indication.	–
Enable	Enables I/Q short circuit detection. Reflects I/Q status in diagnostic information or LED indication.	Initial value

### LED display when I/Q short circuit is detected

LED display is as follows when an I/Q short circuit is detected.

Parameter	LED status			
	P1, P2, P3, P4		MS	
	Color of LED	ON or flashing	Color of LED	ON or flashing
L+ short circuit detected (between I/O port pins 1 and 3)	Red	ON	Green	Flashing
I/Q short circuit detected (between I/O port pins 2 and 5)	None		Green	Flashing

## Forced Output

With the forced output function, commands are issued from the I/O Configurator (NFC version) directly to the wireless base/remote.

With EX600-WLXB1 / EX600-WLYB1, it is possible to transition to forced output mode from the I/O Configurator, but there is no actual data output performed.

# Additional Information

## Relation between Number of Module Occupied Points and Process Data Size

### ■ Process data size assignment (how data areas are allocated)

When setting the process data length, port process data size, and number of module occupied points (data length) for an IO-Link device being connected, ensure there will be sufficient data area so that a size lower in the hierarchy does not exceed an upper level size. Ensure settings are made appropriately in instances such as when a data length to be used by an IO-Link device is larger than its initial value, when optimizing or adjusting data areas, etc.



- If data occupied lengths are not matched, there is a risk of equipment malfunction and unexpected operation.

- Conditions for process data size allocation  
Set each of the input and output so that the following conditions are met.

- (1) [number of module occupied points when paired] ≥ [total of each port's process data size] + 8 bytes\*<sup>1</sup>
- (2) [total of each port's process data size] ≤ 24 bytes (connected to EX600-WEN)  
[total of each port's process data size] ≤ 8 bytes (connected to EX600-WPN)
- (3) [each port's process data size] ≥ [maximum data length used by connected IO-Link device]

\*1 The lead 8 bytes of each input/output of module occupied data for a remote are assigned as a fixed length (used for SIO data, port status, etc.).

Number of module occupied points

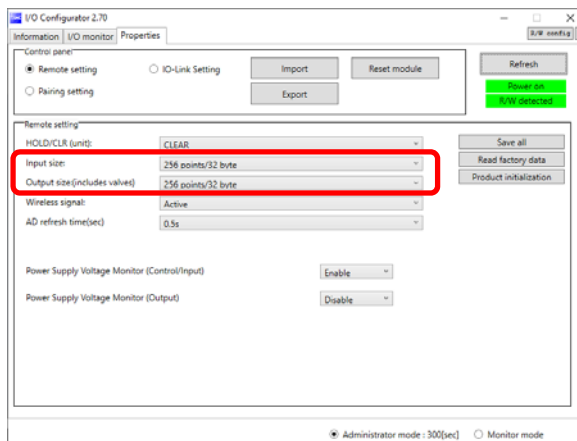

Remote setting

Each port's process data size

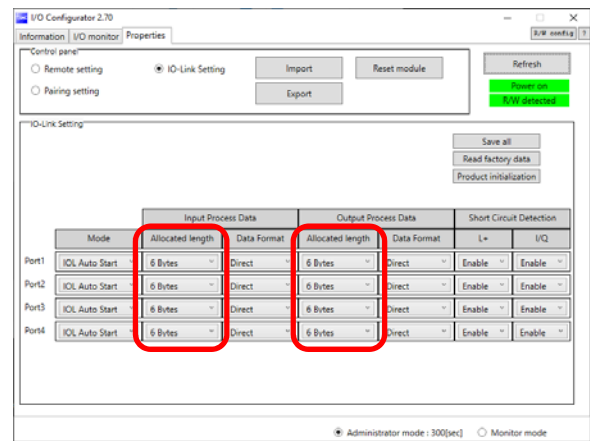

Port setting

## ■ How to change size (when making settings)

When changing the number of module occupied points and the process data size setting, the change might not be applied depending on the order in which the setting is performed.

To make a change, be sure to follow the procedure described hereafter, while being careful to meet the "conditions for process data size allocation" described on the previous page.

- How to change number of module occupied points

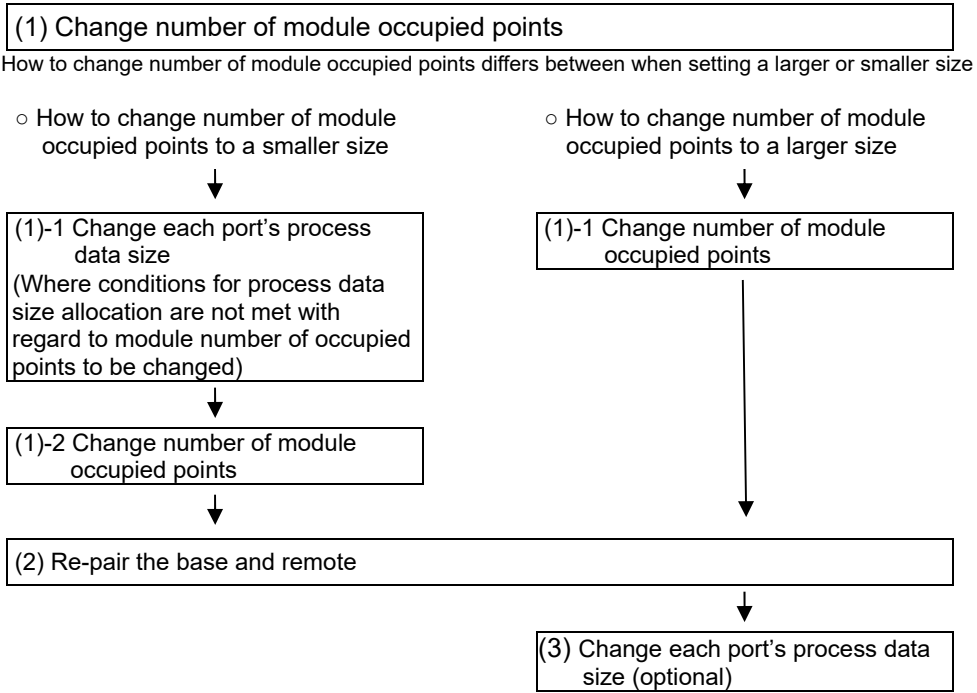

## Wireless System Parameter List

		Parameter name	Set value	Initial value	Setting when not energized	Notes
Information	–	TAG	Max. 15 characters	Part no.	Yes	Letters which can be input are single-byte characters (alphabets, numbers, symbols) that correspond to ASCII code. Half-width katakana cannot be entered. Writing from the base to the remote is not possible during a non-energized state.
Setting	Remote setting	HOLD/CLR (unit)	CLEAR / HOLD	CLEAR	Yes	Set how the output operates when fieldbus communication is disconnected. CLEAR: Clear the output (reset to initial state when communication is disconnected) HOLD: Lock the output at the current value (maintain at value when communication was disconnected)
		Input size	64 points/8 byte to 256 points/32 byte (select in 16-point/2-byte units)	256 points/32 byte	Yes	Set the number of occupied points for the remote module input. If the base is EX600-WEN*, the number of occupied points for the module input will be a maximum 256 points/32 bytes. If the base is EX600-WPN*, the number of occupied points for the module input will be a maximum 128 points/16 bytes.
		Output size (includes values)	64 points/8 byte to 256 points/32 byte (select in 16-point/2-byte units)	256 points/32 byte	Yes	Set the number of occupied points for the remote module output. If the base is EX600-WEN*, the number of occupied points for the module output will be a maximum 256 points/32 bytes. If the base is EX600-WPN*, the number of occupied points for the module output will be a maximum 128 points/16 bytes.
		Wireless signal	Active / Idle	Active	Yes	Activate/deactivate wireless communication for the remote module. If set to "Idle", the module does not engage in wireless communication.
		AD refresh time (sec)	0.1s / 0.2s / 0.5s / 1s / 2s / 5s / 10s / 30s / 60s	0.5s	Yes	Set the interval in seconds for data updates of the connected analog input unit.
		Power Supply Voltage Monitor (Control/Input)	Disable / Enable	Enable	Yes	Set detection of drops in voltage supplied to L+/L- (between I/O port pins 1 and 3). If detected, it is indicated on the LED.
		Power Supply Voltage Monitor (Output)	Disable / Enable	Disable	Yes	EX600-WLYB1 only. Set detection of drops in voltage supplied to DO/0V (between I/O port pins 2 and 5). If detected, it is indicated on the LED.
		IO-Link setting	Mode	Deactivated / IOL Auto Start / DI	IOL Auto Start	Yes
	Allocated length		0 - 24 bytes (select in 1-byte units)	6 bytes	Yes	Set the data size of input process data / output process data for the IO-Link master WLXB1 / WLYB1). If the base is EX600-WEN*, the total 4-port occupied length will be a maximum 24 bytes for each of input and output. If the base is EX600-WPN*, the total 4-port occupied length will be a maximum 8 bytes for each of input and output.
	Data Format		Direct / Swap 16 Bit / Swap 32 Bit / Swap All	Direct	Yes	Set the byte order of input process data / output process data for the IO-Link device.
	L+ (Short Circuit Detection)		Disable / Enable	Enable	Yes	Set detection of an L+ short circuit (between I/O port pins 1 and 3). If detected, it is indicated on the LED.
	I/Q (Short Circuit Detection)		Disable / Enable	Enable	Yes	[EX600-WLYB1 only] Set detection of an I/Q short circuit (between I/O port pins 2 and 5). If detected, it is indicated on the LED.



- The settings will be reflected any time power first reaches (or after resetting) the remote.

# Example of Output Device Connection

## ■ Supplying output power using a Y junction

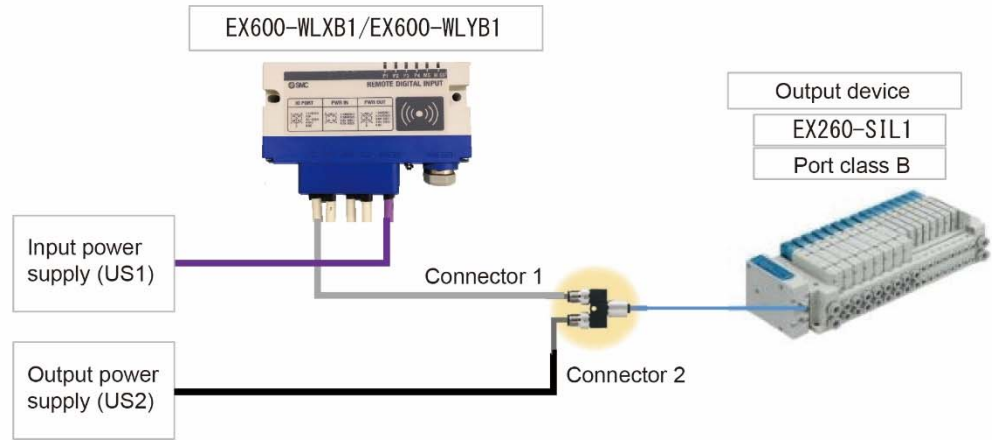

## ■ Supplying output power from DO

Control by the fieldbus (PLC) causes DO (Pin 2) of the port being used to always be ON

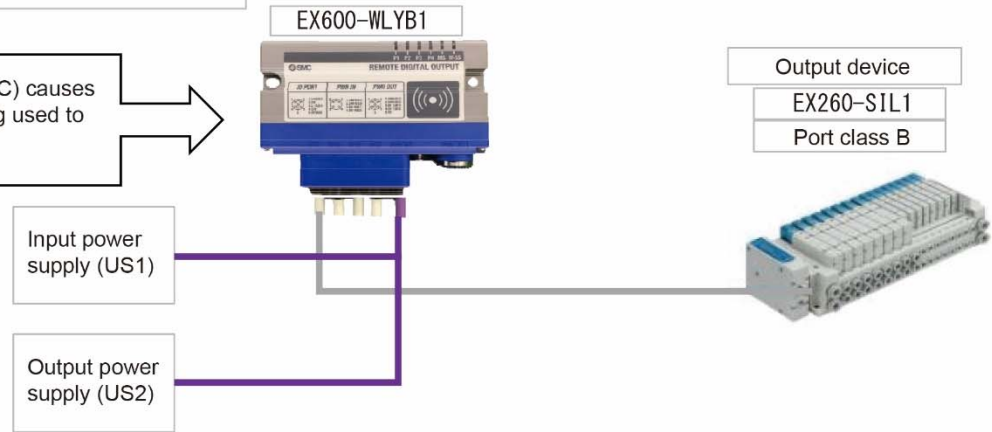





## Specifications

○ EX600-WLXB1 / EX600-WLYB1

### IO-Link communication specifications

Item		EX600-WLXB1		EX600-WLYB1
Communication speed		COM1 (4.8 kBaud) COM2 (38.4 kBaud) COM3 (230.4 kBaud) Automatically switches depending on the connected device.		
Ports for IO-Link device		4		
Max. device supply current		0.3 A/connector (1 A/unit)		
Input	Pin number	2	4	4
	Input type	PNP (-COM)		
	Rated input current	Typ. 2.5 mA	Typ. 5.5 mA	Typ. 5.5 mA
	ON voltage	10.5 V or more (between input terminal and 0 V terminal)		
	OFF voltage	8 V or less (between input terminal and 0 V terminal)		
	Protective functionality	Built-in short circuit prevention		
Output	Pin number	-		2
	Input type	-		PNP (-COM)
	Maximum load current	-		0.1 A/output

\* Suitable 2-wire sensor: 5 V or less internal voltage drop and 5 mA or less load current minimum

### Electrical specifications

Item		EX600-WLXB1		EX600-WLYB1
US1 (for control and input)	Power supply voltage	24 VDC +/-10%		
	Current consumption	100 mA or less (*)	50 mA or less (*)	
US2 (for output)	Power supply voltage	24 VDC +/-10%		
	Current consumption	2 A		

\* All ports unconnected, body only

### General specifications

Item	Specifications
Enclosure rating	IP67
Cable tensile force	100 N
Ambient (operating) temperature	0 to +50°C
Ambient (storage) temperature	-10 to +60°C
Ambient humidity	35 to 85% RH (no condensation)
Withstand voltage	500 VAC-1 minute between external terminals and metallic parts
Insulation resistance	10 MΩ or more (500 VDC between external terminals and metallic parts)
Vibration resistance	EN61131-2 compliant 5 ≤ f < 8.4 Hz 3.5 mm 8.4 ≤ f < 150 Hz 9.8 m/s <sup>2</sup>
Impact resistance	EN61131-2 compliant, 147 m/s <sup>2</sup> , 11 ms
Mounting	Through hole for M4 screw (2 pcs.)
Standards	CE mark (EMC directive, RoHS directive)
Weight	230 g

### Wireless communication specifications

Item	Specifications
Protocol	SMC original protocol (SMC encryption)
Transmission method (spread)	Frequency Hopping Spread Spectrum (FHSS)
Frequency	2.4 GHz (2403 to 2481 MHz)
Frequency channel	79 ch (Bandwidth: 1.0 MHz)
Communication speed	250 kbps
Communication distance	Within 10 m (depending on the operating environment)
Radio Law certification	Construction design certificate (in Japan), FCC (US), ISED (CA), RED (EU), SRRC (CH)

### NFC communication specifications

Item	Specifications
Communication standard	ISO/IEC14443B (Type-B)
Frequency	13.56 MHz
Communication speed	20 to 100 kHz I2C
Communication distance	Up to 1 cm

\* NFC component is a 13.56 MHz passive-type RFID tag.

## Terminology

	Term	Definition
A	Administrator mode	With the I/O Configurator (NFC version), mode allowing parameters to be changed.
	Allocated length	Process data size. Unit of size for input/output data allocated in memory, etc. Set a length the same or larger than a meaningful bit length for the actual input/output string of data. When using this product in IO-Link mode, the set name of the data length assigned to each port with the I/O Configurator (NFC version).
B	Base	A unit which carries out wireless communication with a remote. It is connected to a fieldbus (PLC) and carries out communication using input or output data.
	Broken line detection	This diagnostic function detects a broken connection in an input or output device or in its wiring.
C	Current consumption	Current which is necessary to operate each unit.
D	Data Format	When using this product in IO-Link mode, the set name when setting the byte order with regard to I/O process data for each port with the I/O Configurator (NFC version).
	DI	Digital Input. Digital input in SIO (Standard Input/Output) mode.
	DO	Digital Output. Digital output in SIO (Standard Input/Output) mode.
	Dummy remote	When setting pairing at the base module, a setting made to reserve a data area without allocating a remote module to a wireless channel. Can be set using the I/O Configurator (NFC version).
E	Enclosure rating (IP□□)	Abbreviation of International Protection. Standard related to protection against external influences on a product, such as hands, steel balls, steel wire, dust particles, or water.
F	FG terminal	Ground connection terminal. FG is an abbreviation of Frame Ground. Indicates a ground for preventing noise and mis-operation.
I	Input/Output monitor	I/O map information for a wireless unit. Can be viewed using the I/O Configurator (NFC version).
	IOL Auto Start	IO-Link Auto Start. Set name when using a mode wherein an IO-Link device carries out IO-Link-mode data input/output. Make settings using the I/O Configurator (NFC version).
	IO-Link	Industrial interface standard designed to allow connection between a sensor and actuator with regard to an industrial Ethernet using two-way digital communication.
	I/Q short circuit detection	Detection of a short circuit between pins 2 and 5 of the I/O port. When set to [Enable] on the I/O Configurator (NFC version), an LED lights when a short circuit is detected on the output (US2) circuit.
L	L+ short circuit detection	Detection of a short circuit between pins 1 and 3 of the I/O port. When set to [Enable] on the I/O Configurator (NFC version), an LED lights when a short circuit is detected on the control/input (US1) circuit.
M	Manifold	A branching object. An object providing convergence.
	Module occupied points	A size set for the data area on a base module used by a remote module. The area is reserved at the base module when pairing using the I/O Configurator (NFC version).
	Monitor mode	With the I/O Configurator (NFC version), a mode allowing parameters to be read only.
	MS (LED name)	Module Status. Indicates the module status.
N	NFC	Near Field Communication. Non-contact short distance wireless communication. It allows access using a card reader/writer by using a special application.
	NS (LED name)	Network Status. Indicates the status of upper level communication with a base.
	Number of inputs	Number of points which can receive information from input devices such as a sensor or switch.
	Number of outputs	Number of points which can operate output equipment such as a valve, lamp or motor starter.

	Term	Definition
P	Pairing	Two devices authenticating each other. The PID (Product ID) of a connectable remote is registered to a base. Register the PID as an initial setting; once registered, the wireless system will activate.
	PID	Product ID. A numeric string of 32-bit allocated to identify the wireless unit (base/remote).
	PLC	Programmable Logic Controller. A digital computer used for automation of electromechanical processes.
	PNP input	Incorporates a sensor output that uses a PNP transistor as the signal output component.
	PNP output	The output type that uses a PNP transistor to operate an output device. It is also known as a negative common type since a negative potential is applied to the power supply line.
	Port process data size	Data area allocated to each I/O port of a remote module used in IO-Link mode. Ensure a data length the same or more as required for input/output with the connected IO-Link device. Can be set using the I/O Configurator (NFC version).
	Power Supply Voltage Monitor (Control/Input)	Provides the detection of drops in voltage supplied between [L+]/[L-] (between I/O port pins 1 and 3). Can be set using the I/O Configurator (NFC version).
	Power Supply Voltage Monitor (Output)	Provides the detection of drops in voltage supplied to [DO]/[0V] (between I/O port pins 2 and 5). Can be set using the I/O Configurator (NFC version).
	PWR	Power. Indicates power supply.
R	Remote	A unit which carries out wireless communication with a base using input or output data.
S	Short circuit detection	Diagnostic function which detects generation of overcurrent due to a short circuit between the output and the positive power supply line or the ground line.
	Short circuit protection	Function which prevents damage to the internal circuit when an overcurrent is generated due to a short circuit between the output and the positive power line or the ground line.
	SIO	Standard Input and Output.
	Swap 16 Bit	When changing the byte order of I/O data using the I/O Configurator (NFC version), changes the order of bytes in 1-byte units, in units having a 2-byte range from the head of data allocated for the process data size. Swapping is not performed for data not matching the range in which the order is changed.
	Swap 32 Bit	When changing the byte order of I/O data using the I/O Configurator (NFC version), changes the order of bytes in 1-byte units, in units having a 4-byte range from the head of data allocated for the process data size. Swapping is not performed for data not matching the range in which the order is changed.
	Swap All	When changing the byte order of I/O data using the I/O Configurator (NFC version), changes the end order of bytes in 1-byte units, in order starting from the end, from the head of data allocated for the process data size. Swapping is also performed for data not matching the range in which the order is changed, and is stored to/retrieved from the head of the allocated data area.
W	W-MS (LED name)	Wireless Module Status. Indicates the status of the remote registered to the base.
	W-NS (LED name)	Wireless Network Status. Indicates the communication status of the remote registered to the base.
	W-SS (LED name)	Wireless Signal Strength. Indicates the received radio wave intensity.
	Wireless channel	Identification number of a remote unit connected to a base.
	Wireless system	A general term for a network including base and remote units.
	Wireless unit	A unit which carries out wireless communication. A general term for a base or remote.

# Accessories (Sold Separately)

(1) Seal cap (10 pcs.)

EX9-AWTS



(2) Power supply cable (usable together with IO-Link port)

EX9-AC-**005**-SSPS (connector at both ends (socket/plug))

Cable length [L]	
005	500 mm
010	1000 mm
020	2000 mm
030	3000 mm
050	5000 mm
100	10000 mm

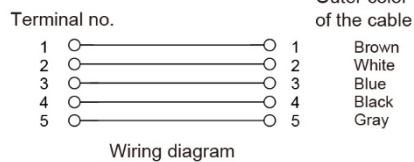
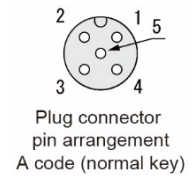
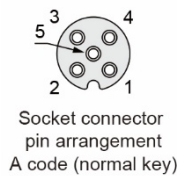

Item	Specifications
Cable O.D.	ø6 mm
Nominal cross-section of the conductor	0.3 mm <sup>2</sup> (AWG22)
Wire diameter (including insulator)	1.5 mm
Minimum bending radius (when fixed)	40 mm

(3) Y junction connector for IO-Link

EX9-ACY02-S

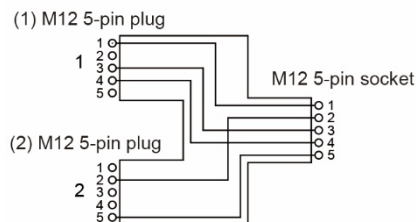
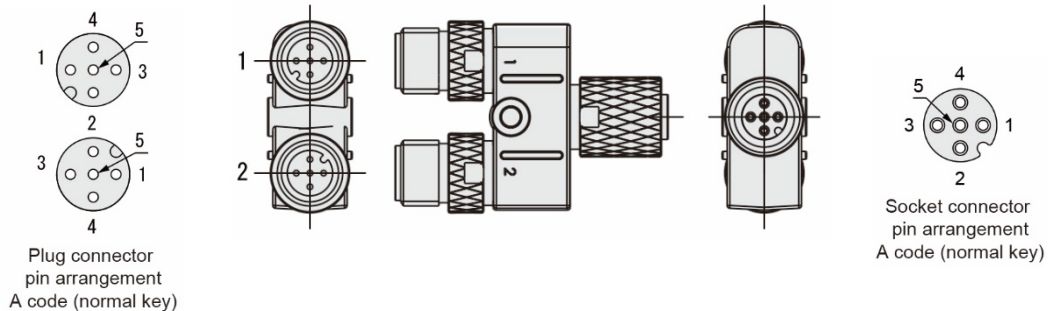

Plug connector 2 Pin arrangement

1	—	Not used
2	SV24V	+24 V for solenoid valve
3	—	Not used
4	—	Not used
5	SV0V	0 V for solenoid valve

Example supplying power from junction connector to solenoid valve

Revision history

# SMC Corporation

4-14-1, Sotokanda, Chiyoda-ku, Tokyo 101-0021 JAPAN

Tel: + 81 3 5207 8249 Fax: +81 3 5298 5362

URL <https://www.smcworld.com>

---

Note: Specifications are subject to change without prior notice and any obligation on the part of the manufacturer.

EtherNet/IP™ is a trademark of ODVA.

© 2020 SMC Corporation All Rights Reserved

