



Operation Manual

PRODUCT NAME

SMC Wireless System Compact remote

MODEL/ Series/ Product Number

EX600-WD□ (Remote)

SMC Corporation





Safety Instructions

These safety instructions are intended to prevent hazardous situations and/or equipment damage. These instructions indicate the level of potential hazard with the labels of "Caution", "Warning" or "Danger".

They are all important notes for safety and must be followed in addition to International Standards (ISO/IEC)*1), and other safety regulations.

*1) ISO 4414: Pneumatic fluid power -- General rules relating to systems.

ISO 4413: Hydraulic fluid power -- General rules relating to systems.

IEC 60204-1: Safety of machinery -- Electrical equipment of machines. (Part 1: General requirements)

ISO 10218: Manipulating industrial robots -Safety.

etc.



Caution

Caution indicates a hazard with a low level of risk which, if not avoided, could result in minor or moderate injury.



Warning

Warning indicates a hazard with a medium level of risk which, if not avoided, could result in death or serious injury.



Danger

Danger indicates a hazard with a high level of risk which, if not avoided, will result in death or serious injury.

Warning

1. The compatibility of the product is the responsibility of the person who designs the equipment or decides its specifications.

Since the product specified here is used under various operating conditions, its compatibility with specific equipment must be decided by the person who designs the equipment or decides its specifications based on necessary analysis and test results.

The expected performance and safety assurance of the equipment will be the responsibility of the person who has determined its compatibility with the product.

This person should also continuously review all specifications of the product referring to its latest catalog information, with a view to giving due consideration to any possibility of equipment failure when configuring the equipment.

2. Only personnel with appropriate training should operate machinery and equipment.

The product specified here may become unsafe if handled incorrectly.

The assembly, operation and maintenance of machines or equipment including our products must be performed by an operator who is appropriately trained and experienced.

3. Do not service or attempt to remove product and machinery/equipment until safety is confirmed.

1. The inspection and maintenance of machinery/equipment should only be performed after measures to prevent falling or runaway of the driven objects have been confirmed.

2. When the product is to be removed, confirm that the safety measures as mentioned above are implemented and the power from any appropriate source is cut, and read and understand the specific product precautions of all relevant products carefully.

3. Before machinery/equipment is restarted, take measures to prevent unexpected operation and malfunction.

4. Contact SMC beforehand and take special consideration of safety measures if the product is to be used in any of the following conditions.

1. Conditions and environments outside of the given specifications, or use outdoors or in a place exposed to direct sunlight.

2. Installation on equipment in conjunction with atomic energy, railways, air navigation, space, shipping, vehicles, military, medical treatment, combustion and recreation, or equipment in contact with food and beverages, emergency stop circuits, clutch and brake circuits in press applications, safety equipment or other applications unsuitable for the standard specifications described in the product catalog.

3. An application which could have negative effects on people, property, or animals requiring special safety analysis.

4. Use in an interlock circuit, which requires the provision of double interlock for possible failure by using a mechanical protective function, and periodical checks to confirm proper operation.



Safety Instructions

Caution

1. The product is provided for use in manufacturing industries.

The product herein described is basically provided for peaceful use in manufacturing industries. If considering using the product in other industries, consult SMC beforehand and exchange specifications or a contract if necessary.
If anything is unclear, contact your nearest sales branch.

Limited warranty and Disclaimer/Compliance Requirements

The product used is subject to the following "Limited warranty and Disclaimer" and "Compliance Requirements".

Read and accept them before using the product.

Limited warranty and Disclaimer

1. The warranty period of the product is 1 year in service or 1.5 years after the product is delivered, whichever is first.*2)
Also, the product may have specified durability, running distance or replacement parts. Please consult your nearest sales branch.

2. For any failure or damage reported within the warranty period which is clearly our responsibility, a replacement product or necessary parts will be provided.
This limited warranty applies only to our product independently, and not to any other damage incurred due to the failure of the product.

3. Prior to using SMC products, please read and understand the warranty terms and disclaimers noted in the specified catalog for the particular products.

***2) Vacuum pads are excluded from this 1 year warranty.**

A vacuum pad is a consumable part, so it is warranted for a year after it is delivered. Also, even within the warranty period, the wear of a product due to the use of the vacuum pad or failure due to the deterioration of rubber material are not covered by the limited warranty.

Compliance Requirements

1. The use of SMC products with production equipment for the manufacture of weapons of mass destruction (WMD) or any other weapon is strictly prohibited.

2. The exports of SMC products or technology from one country to another are governed by the relevant security laws and regulation of the countries involved in the transaction. Prior to the shipment of a SMC product to another country, assure that all local rules governing that export are known and followed.

Operator

- ◆ This operation manual is intended for those who have knowledge of machinery using pneumatic equipment, and have sufficient knowledge of assembly, operation and maintenance of such equipment. Only those persons are allowed to perform assembly, operation and maintenance.
- ◆ Read and understand this operation manual carefully before assembling, operating or providing maintenance to the product.

■ Safety Instructions

Warning

- Do not disassemble, modify (including changing the printed circuit board) or repair.
An injury or failure can result.
- Do not operate or set with wet hands.
This may lead to an electric shock.
- Do not operate the product outside of the specifications.
Do not use for flammable or harmful fluids.
Fire, malfunction, or damage to the product can result.
Verify the specifications before use.
- Do not operate in an atmosphere containing flammable or explosive gases.
Fire or an explosion can result.
This product is not designed to be explosion proof.
- If using the product in an interlocking circuit:
 - Provide a double interlocking system, for example a mechanical system.
 - Check the product regularly for proper operation.Otherwise malfunction can result, causing an accident.
- The following instructions must be followed during maintenance:
 - Turn off the power supply.
 - Stop the air supply, exhaust the residual pressure and verify that the air is released before performing maintenance.Otherwise an injury can result.

Caution

- When handling the unit or assembling/replacing units:
 - Do not touch the sharp metal parts of the connector or plug for connecting units.
 - Take care not to hit your hand when disassembling the unit.
The connecting portions of the unit are firmly joined with seals.
 - When joining units, take care not to get fingers caught between units.
An injury can result.

- After maintenance is complete, perform appropriate functional inspections.
Stop operation if the equipment does not function properly.
Safety cannot be assured in the case of unexpected malfunction.

- Provide grounding to assure noise resistance of the Fieldbus system.
Individual grounding should be provided close to the product with a short cable.

Caution

Notice:

Changes or modifications not expressly approved by the manufacturer could void the user's authority to operate the equipment.

NOTE:

This equipment has been tested and found to comply with the limits for a Class A digital device, pursuant to Part 15 of the FCC Rules.

These limits are designed to provide reasonable protection against harmful interference when the equipment is operated in a commercial environment.

This equipment generates, uses, and can radiate radio frequency energy and, if not installed and used in accordance with the instruction manual, may cause harmful interference to radio communications.

Operation of this equipment in a residential area is likely to cause harmful interference in which case the user will be required to correct the interference at his own expense.

This device complies with Industry Canada's licence-exempt RSSs. Operation is subject to the following two conditions:

- (1) This device may not cause interference; and
- (2) This device must accept any interference, including interference that may cause undesired operation of the device.

Le présent appareil est conforme aux CNR d'Industrie Canada applicables aux appareils radio exempts de licence. L'exploitation est autorisée aux deux conditions suivantes:

- (1) l'appareil ne doit pas produire de brouillage, et
- (2) l'utilisateur de l'appareil doit accepter tout brouillage radioélectrique subi, même si le brouillage est susceptible d'en compromettre le fonctionnement.

Caution

When operating the product, please be sure to maintain a separation distance of at least 20cm between your body (excluding fingers, hands, wrists, ankles and feet) and the product to meet RF exposure safety requirements as determined by FCC and Innovation, Science and Economic Development Canada. Installation of this device must ensure that at 20cm separation distance is maintained between the device and end users.

警語

經型式認證合格之低功率射頻電機，非經許可，公司、商號或使用者均不得擅自變更頻率、加大功率或變更原設計之特性及功能。

低功率射頻電機之使用不得影響飛航安全及干擾合法通信；經發現有干擾現象時，應立即停用，並改善至無干擾時方得繼續使用。

前項合法通信，指依電信法規定作業之無線電通信。低功率射頻電機須忍受合法通信或工業、科學及醫療用電波輻射性電機設備之干擾。

■NOTE

- Follow the instructions given below when designing, selecting and handling the product.
- The instructions on design and selection (installation, wiring, environment, adjustment, operation, maintenance, etc.) described below must also be followed.
 - *Product specifications
 - Use the specified voltage.
Otherwise failure or malfunction can result.
 - Reserve a space for maintenance.
Allow sufficient space for maintenance when designing the system.
 - Do not remove any nameplates or labels.
This can lead to incorrect maintenance, or misreading of the operation manual, which could cause damage or malfunction to the product.
It may also result in non-conformity to safety standards.
 - Beware of inrush current when the power supply is turned on.
Some connected loads can apply an initial charge current which will activate the over current protection function, causing the unit to malfunction.
 - Product handling
 - *Installation
 - Do not drop, hit or apply excessive shock to the SI unit.
Otherwise damage to the product can result, causing malfunction.
 - Tighten to the specified tightening torque.
If the tightening torque is exceeded the mounting screws may be broken.
IP67 protection cannot be guaranteed if the screws are not tightened to the specified torque.
 - If a large manifold valve is mounted, lift the unit so that stress is not applied to the connecting part while transporting.
The stress may cause breakage of the connecting part. The unit may become very heavy depending on the combination. Transportation/installation shall be performed by multiple operators.
 - Never mount a product in a location that will be used as a foothold.
The product may be damaged if excessive force is applied by stepping or climbing onto it.
 - *Wiring
 - Avoid repeatedly bending or stretching the cables, or placing heavy load on them.
Repetitive bending stress or tensile stress can cause breakage of the cable.
 - Wire correctly.
Incorrect wiring can break the product.
 - Do not perform wiring while the power is on.
Otherwise damage to the wireless unit and/or input or output device can result, causing malfunction.
 - Do not route wires and cables together with power or high voltage cables.
Otherwise the wireless unit and/or input or output device can malfunction due to interference of noise and surge voltage from power and high voltage cables to the signal line.
Route the wires (piping) of the wireless unit and/or input or output device separately from power or high voltage cables.
 - Confirm proper insulation of wiring.
Poor insulation (interference from another circuit, poor insulation between terminals, etc.) can lead to excess voltage or current being applied to the product, causing damage.
 - Take appropriate measures against noise, such as using a noise filter, when the Fieldbus system is incorporated into equipment.
Otherwise noise can cause malfunction.

*Environment

- Select the proper type of protection according to the environment of operation.

IP67 protection class is achieved when the following conditions are met.

(1) The units are connected properly with fieldbus cable with M12 connector and power cable with M12 (M8) connector.

(2) Suitable mounting of each unit and manifold valve.

(3) Be sure to fit a waterproof cap on any unused connectors.

If using in an environment that is exposed to water splashes, please take measures such as using a cover.

Do not use in an environment where moisture or water vapor are present. Otherwise failure and malfunction can result.

- Do not use in a place where the product could be splashed by oil or chemicals.

If the product is to be used in an environment containing oils or chemicals such as coolant or cleaning solvent, even for a short time, it may be adversely affected (damage, malfunction etc.).

- Do not use the product in an environment where corrosive gases or fluids could be splashed.

Otherwise damage to the product and malfunction can result.

- Do not use in an area where surges are generated.

If there is equipment generating large surge near the unit (magnetic type lifter, high frequency inductive furnace, welding machine, motor, etc.), this can cause deterioration of the internal circuitry element of the unit or result in damage. Take measures against the surge sources, and prevent the lines from coming into close contact.

- When a surge-generating load such as a relay, valve or lamp is driven directly, use a product with a built-in surge absorbing element.

Direct drive of a load generating surge voltage can damage the unit.

- The product is CE marked, but not immune to lightning strikes. Take measures against lightning strikes in the system.

- Prevent foreign matter such as dust or wire debris from getting inside the product.

- Mount the product in a place that is not exposed to vibration or impact.

Otherwise failure or malfunction can result.

- Do not use the product in an environment that is exposed to temperature cycle.

Heat cycles other than ordinary changes in temperature can adversely affect the inside of the product.

- Do not expose the product to direct sunlight.

If using in a location directly exposed to sunlight, shade the product from the sunlight.

Otherwise failure or malfunction can result.

- Keep within the specified ambient temperature range.

Otherwise malfunction can result.

- Do not operate close to a heat source, or in a location exposed to radiant heat.

Otherwise malfunction can result.

*Adjustment and Operation

- Please refer to the I/O configuration manual for details of parameter settings.

- Perform settings suitable for the operating conditions.

Incorrect setting can cause operation failure.

(Refer to page [エラー! ブックマークが定義されていません。](#) for the Setting and Adjustment.)

- Please refer to the PLC manufacturer's manual etc. for details of programming and addresses.

For the PLC protocol and programming refer to the relevant manufacturer's documentation.



*Maintenance

- Turn off the power supply, stop the supplied air, exhaust the residual pressure and verify the release of air before performing maintenance.

There is a risk of unexpected malfunction.

- Perform regular maintenance and inspections.

There is a risk of unexpected malfunction.

- After maintenance is complete, perform appropriate functional inspections.

Stop operation if the equipment does not function properly.

Otherwise safety is not assured due to an unexpected malfunction or incorrect operation.

- Do not use solvents such as benzene, thinner etc. to clean each unit.

They could damage the surface of the body and erase the markings on the body.

Use a soft cloth to remove stains.

For heavy stains, use a cloth soaked with diluted neutral detergent and fully squeezed, then wipe up the stains again with a dry cloth.

SMC Wireless System Features

The SMC wireless system has the following features.

- Quick start-up takes 0.25 sec.(minimum) to connect to the system when the remote is powered. *1
- Parameter setting by Near Field Communication (NFC) using a PC (no HW setting).
- A maximum of 127 remotes can be registered to one base *2.
- The maximum number of I/O points of wireless system is 1280 for input and output. *3,4
- The maximum number of base I/O points is 128 for input and 128 for output.
- The maximum number of remote I/O points is 128 for input and 128 for output.

*1: The base is in start-up mode, and will change depending on the remote power-on timing and external influences.

*2: The maximum number of units that can be connected is 127. If 127 units is exceeded, the unit I/O will not be recognised.

There might be communication delay depending on the communication load status.

※3 : The maximum number of I/O points is 1280 for input and 1280 for output. When exceeding 1280 points, the unit I/O is not recognized.

There might be communication delay depending on the communication load status.

※4: Total number of base I/O points and registered remote I/O points.

<Important>

The product is certified as a wireless equipment in accordance with the Radio Act and the certification of construction type has been obtained. Customers do not need to apply for a license to use this equipment.

Be sure to comply with the following precautions.

- Do not disassemble or modify the product. Disassembly and modification are prohibited by law.

This product is compliant with the Radio Act in Japan. For use in other countries, please consult SMC.

- This product communicates by radio waves, and the communication may stop instantaneously due to ambient environments and operating methods. SMC will not be responsible for any secondary failure which may cause an accident or damage to other devices or equipment.
- When several units are installed closely to each other, slight interference may occur due to the characteristics of the wireless product.

Radio waves emitted by this product may adversely affect implantable medical devices such as implantable cardiac pacemakers and implantable defibrillators.

For precautions regarding the use of equipments or devices that may adversely affect performance, refer to the catalogue or instruction manual of the device or equipment, or contact the manufacturer directly.

- The communication performance is affected by the ambient environment, so please perform the communication testing before use.

SMC Wireless System

■ Outline

This system is an I/O distributed system which can be wirelessly connected.

It consists of a combination of a base and remote that has a wireless function with the upper-level device. The base can be combined with an EX600 series I/O unit . Module configuration can be constructed. (See page 11.)

The base can have max. 128 points input and 128 output. By matching the number of remote I/O points, it is possible to have up to 1280 points for input and 1280 points for output.

Therefore, the maximum number of I/O points per 1 node can be 1280 points (160 bytes) / 1280 points (160 bytes) visible from the upper level communication such as a PLC.

By registering the Product ID (PIDs) which are held for each product, the base and remote are designed to prevent malfunction even when multiple base and remote units are operated in the same area.

The packet of the wireless transmit and receive data is encrypted. It is therefore difficult to manipulate the data.

Refer to the Operation Manual for the SMC Wireless System EtherNet/IP, PROFINET type for details.

■ System configuration

<PLC>



"F.B. communication"

<Base>

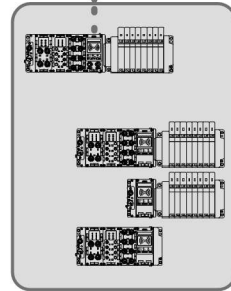
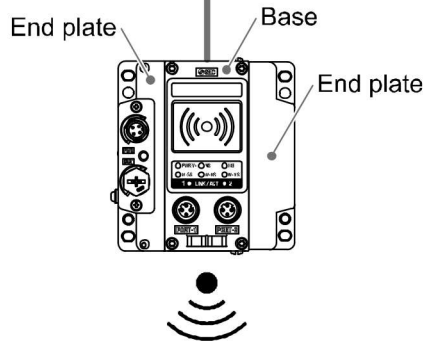

<Remote>

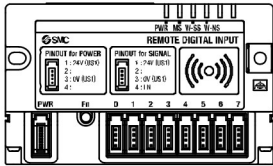

< Connectable devices >

Pressure switch, flow switch, auto switch, other switches (proximity / photoelectric / limit switch, etc.)

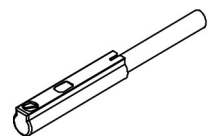
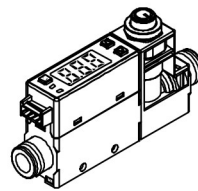
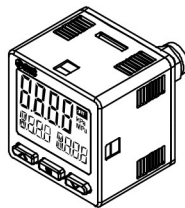
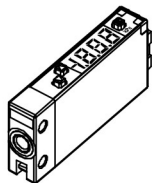
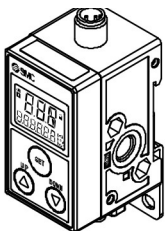

Wireless system configuration example

■ Definition and terminology

Terminology	Definition
FE	Abbreviation of functional earth. The word "earth" refers to this functional earth.
NFC	Abbreviation of Near Field Communication. Non-contact short distance wireless communication. It is accessible using a card reader/ writer by using a special application.
PID	Abbreviation of Product ID. A numeric string of 32-bits allocated to the identify of the wireless unit (base / remote).
PLC	Abbreviation of Programmable Logic Controller. A digital computer used for automation of electromechanical processes.
PNP output	The output type that uses a PNP transistor to operate an output device. It is also known as a negative common type since a negative potential is applied to the power supply line.
PNP Input	Takes the sensor output that uses the PNP transistor to the signal output part.
Number of outputs	Number of points which can operate output equipment such as a valve, lamp or motor starter.
Current consumption	Current which is necessary to operate each unit.
Broken line detection	A broken wire to the input or output equipment has been detected by the diagnostic function.
Short circuit detection	Diagnostic function which detects generation of over current due to a short circuit between the output and the positive power supply line or the ground line.
Short circuit protection	Function which avoids damage to the internal circuit when over current is generated due to short circuit between the output and the positive power line or the ground line.
Number of inputs	Number of points which can receive information from input equipment such as a sensor or switch.
Pairing	Registration of the Product ID (PID) of the connectable remote. Registration occurs at the initial setting, then wireless system will activate.
Base	A unit which establishes wireless communication of input or output data to the remote. It is connected to a PLC to establish communication of input or output data.
Enclosure (IP□□)	Abbreviation of International Protection. Standard related to protection against extraneous matter, such as hand, steel ball, steel wire, dust particle or water, applied to the product.
Manifold	Manifold.
Wireless System	A general term for the network including base and remote units.
Wireless channel	Identification number of the remote unit connected to the base.
Wireless unit	Wireless communication unit. A general term for base and remote units.
Remote	A unit which establishes wireless communication of input or output data to the base.

Mounting and Installation

■ Installation

- Direct mounting

EX600-WD□E□

Mount the unit with M4 screws (not included) using the two holes of the unit. (Tightening torque: 1.35 to 1.65 Nm)

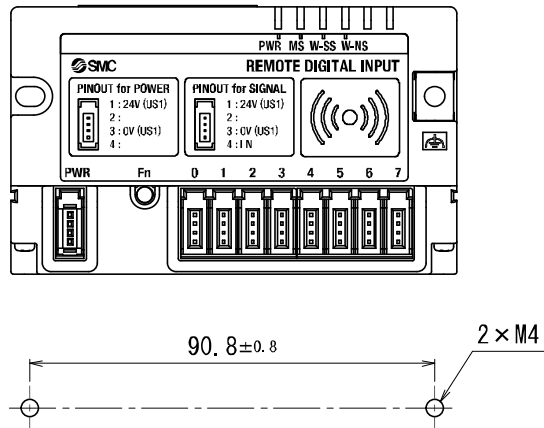

Recommended mounting hole dimensions

EX600-WD□A□

Mount the unit with M5 screws (not included) using the four holes of the unit. (Tightening torque: 2.7 to 3.3 Nm)

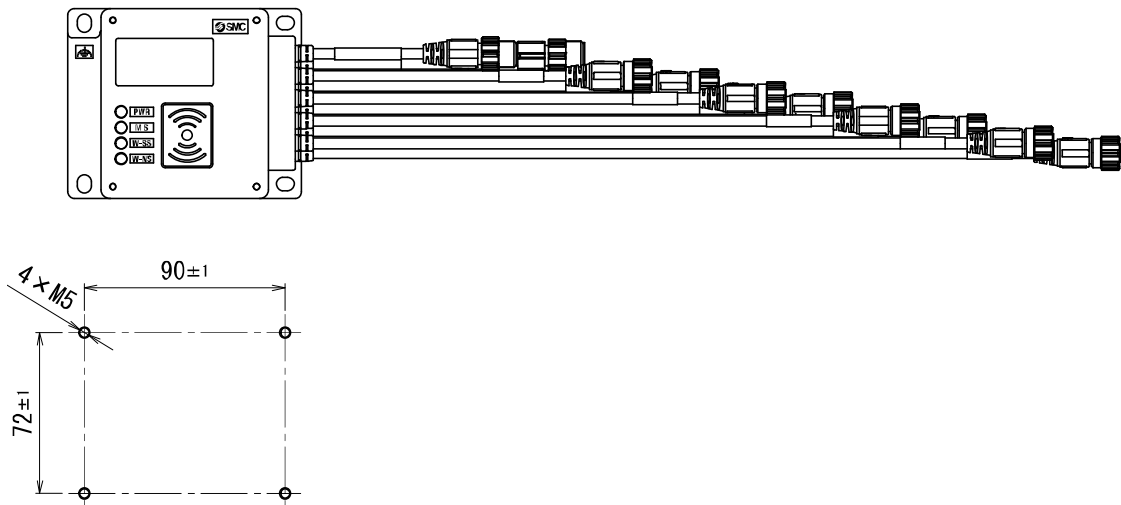

Recommended mounting hole dimensions

How to Order

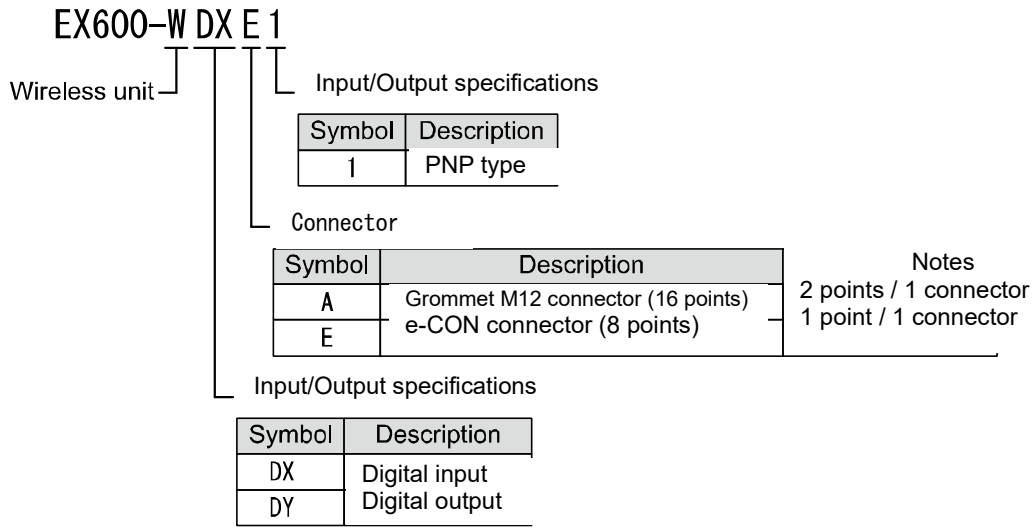

Summary of Product parts

○EX600-WDXE1

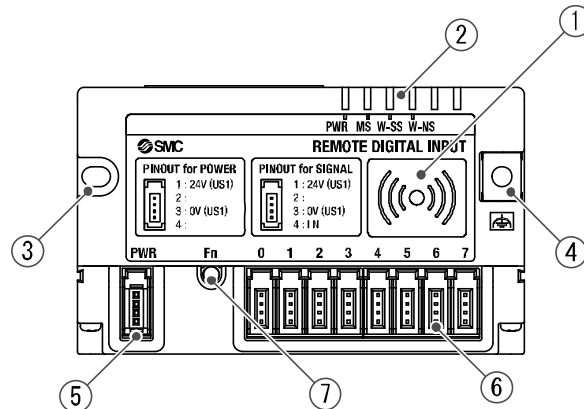

No.	Description	Application
1	Area close to NFC antenna	This area is in close contact with the NFC reader / writer. "O" is the center of the NFC antenna.
2	Status LED	LED display to indicate the unit status.
3	Screw hole for mounting (M4 x 2)	Holds the remote.
4	FG terminal *	To be connected to Ground (for better noise immunity).
5	Power supply connector	Supplies power to the unit.
6	Connector for input equipment	Connect the input equipment
7	Pairing button	Pressed when switching to pairing mode.

Grounding should be as close as possible to the product and the grounding distance should be as short as possible.

○EX600-WDYE1

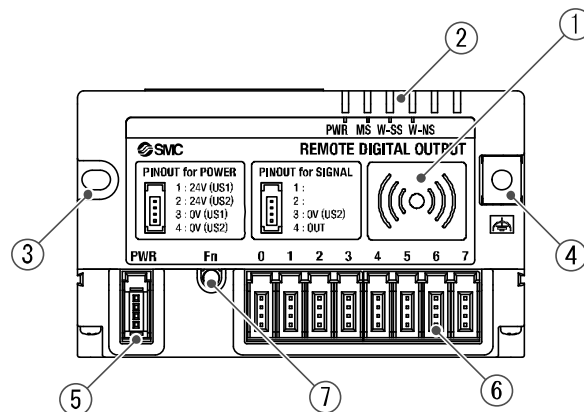

No.	Name	Application
1	Area close to NFC antenna	This area is in close contact with the NFC reader / writer. "O" is the center of the NFC antenna.
2	Status LED	LED display to indicate the unit status.
3	Screw hole for mounting (M4 x 2)	Holds the remote.
4	FG terminal *	To be connected to Ground (for better noise immunity).
5	Power supply connector	Supplies power to the unit.
6	Connector for output equipment	Connect the output equipment
7	Pairing button	Pressed when switching to pairing mode.

Grounding should be as close as possible to the product and the grounding distance should be as short as possible.

○EX600-WDXA1

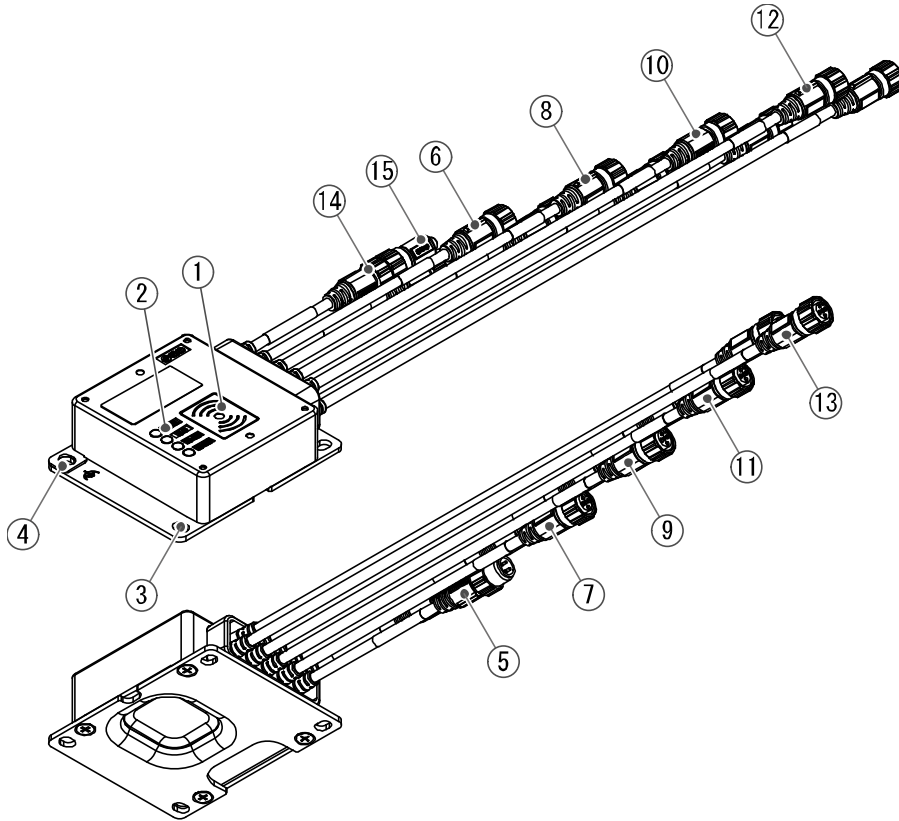

No.	Name	Application
1	Area close to NFC antenna	This area is in close contact with the NFC reader / writer. "O" is the center of the NFC antenna.
2	Status LED	LED display to indicate the unit status.
3	Screw hole for mounting (M5 x 4)	Used for installing sheet metals.
4	FG terminal ^{*1}	To be connected to Ground (for better noise immunity).
5	Power supply cable	Connect the power supply for control.
6	Input cable (E/F)	Connect the input equipment (M12 connector)
7	Input cable (C/D)	Connect the input equipment (M12 connector)
8	Input cable (A/B)	Connect the input equipment (M12 connector)
9	Input cable (8/9)	Connect the input equipment (M12 connector)
10	Input cable (6/7)	Connect the input equipment (M12 connector)
11	Input cable (4/5)	Connect the input equipment (M12 connector)
12	Input cable (2/3)	Connect the input equipment (M12 connector)
13	Input cable (0/1)	Connect the input equipment (M12 connector)
14	Pairing cable	Pressed when switching to pairing mode.
15	Short jumper	Connect the jumper connector in normal use, and disconnect the jumper connector when pairing.

*1: Grounding should be as close as possible to the product and the grounding wire should be as short as possible.

*2: Attaching the waterproof cap (EX9-AWTS: not included) to any unused connector can satisfy the enclosure requirement.

○EX600-WDYA1

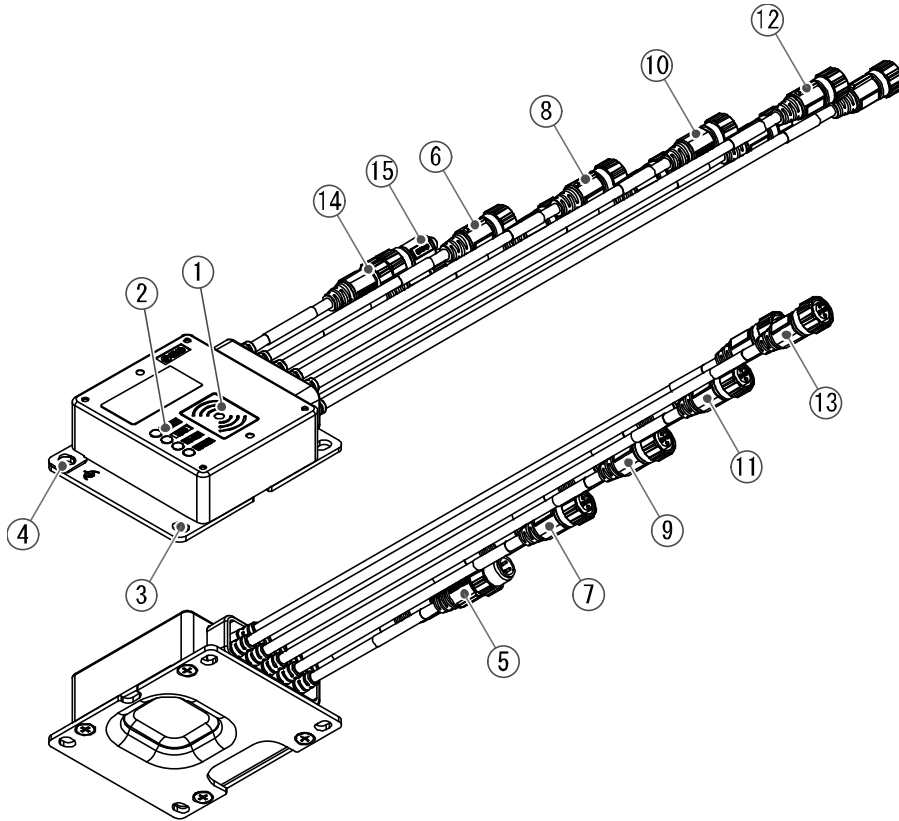

No.	Name	Application
1	Area close to NFC antenna	This area is in close contact with the NFC reader / writer. "O" is the center of the NFC antenna.
2	Status LED	LED display to indicate the unit status.
3	Screw hole for mounting (M5 x 4)	Used for installing sheet metals.
4	FG terminal ^{※1}	To be connected to Ground. (for better noise immunity).
5	Power supply cable	Connect the power supply for control and output.
6	Output cable (E/F)	Connect the output equipment (M12 connector)
7	Output cable (C/D)	Connect the output equipment (M12 connector)
8	Output cable (A/B)	Connect the output equipment (M12 connector)
9	Output cable (8/9)	Connect the output equipment (M12 connector)
10	Output cable (6/7)	Connect the output equipment (M12 connector)
11	Output cable (4/5)	Connect the output equipment (M12 connector)
12	Output cable (2/3)	Connect the output equipment (M12 connector)
13	Output cable (0/1)	Connect the output equipment (M12 connector)
14	Pairing cable	Pressed when switching to pairing mode.
15	Short jumper	Connect the jumper connector normally, and disconnect the jumper connector when pairing.

*1: Grounding should be as close as possible to the product and the grounding wire should be as short as possible.

*2: Attaching the waterproof cap (EX9-AWTS: not included) to any unused connector can satisfy the enclosure requirement.

Wiring

■Wiring and Connection (e-CON type)

Input unit

- Power socket connector wiring specifications

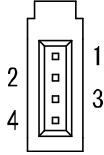

Pin number	Terminal
1	24 V (for control and input)
2	N.C.
3	0 V (for control and input)
4	N.C.

- Wiring of the socket connector for input equipment

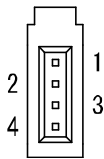

Pin number	Terminal
1	24 V (for control and input)
2	N.C.
3	0 V (for control and input)
4	Input

- Input unit circuit

Connection of the input equipment
Socket x8 (0 to 7)

Power socket (PWR)

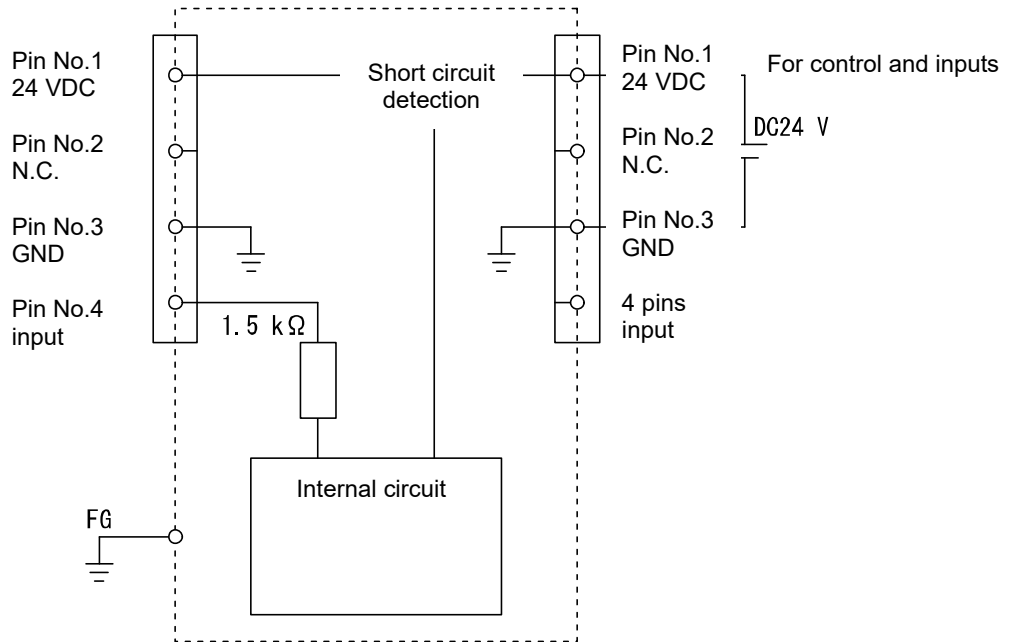

Output unit

- Power socket connector wiring specifications

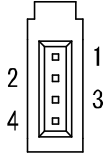

Pin number	Terminal
1	24 V (for control and input)
2	24 V (for output)
3	0 V (for control and input)
4	0 V (for output)

- Wiring of the socket connector for output equipment

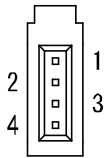

Pin number	Terminal
1	N.C.
2	N.C.
3	0 V (for output)
4	OUT

- Output unit circuit

Connection of the output equipment
Socket ×8 (0 to 7)

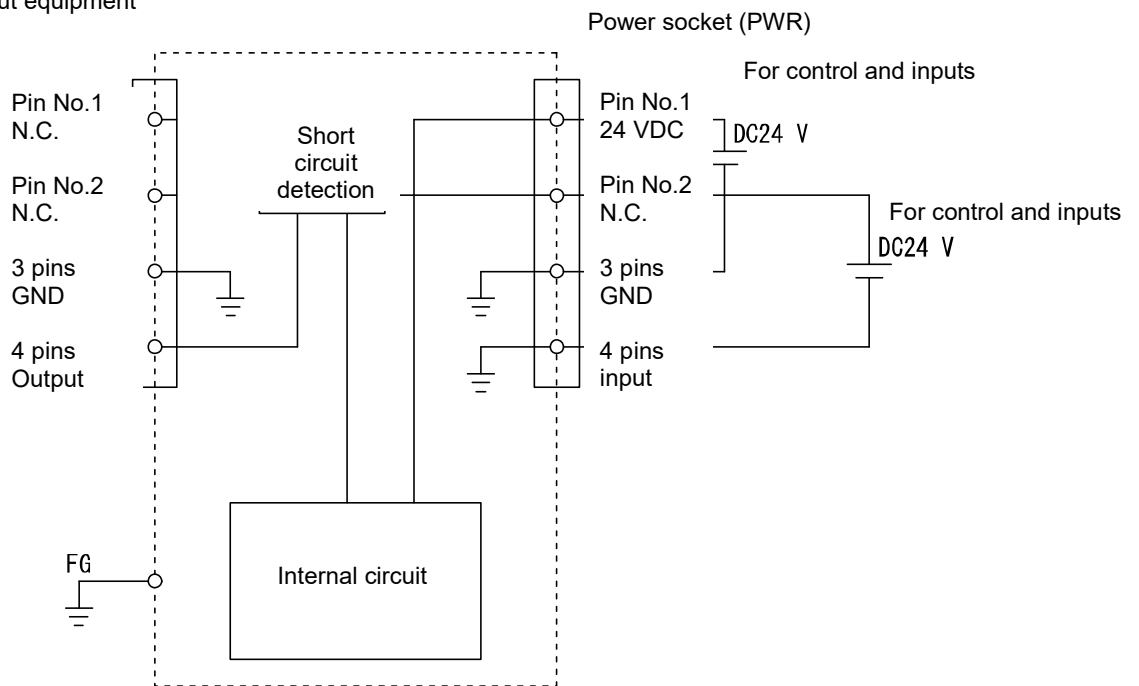

■Wiring and Connection (Grommet Type)

Input unit

- Pairing cable: M12 4-pin plug (male)

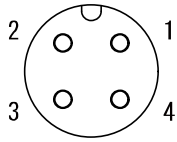

Pin number	Description signal
1	Connector the short jumper connector - When connected: Normal operation mode - When not connected: Pairing mode
2	
3	
4	

Mating connector : M12 4-pin socket A code

- Pairing supply cable: M12 4-pin plug (male)

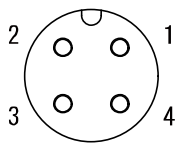

Pin number	Description signal
1	24 V (for control and input)
2	N.C.
3	0 V (for control and input)
4	N.C.

Mating connector : M12 4-pin socket A code

- Input cable : M12 5-pin socket (female)

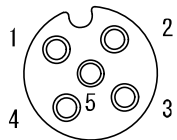

Pin number	Description signal
1	24 V (for control and input)
2	Input n+1
3	0 V (for control and input)
4	Input n
5	N.C.

Mating connector : M12 4-pin (Plug) A code, M12 5-pin (plug) A code

- Input unit circuit

Input cable x 8 (0 to F)

Pin No.1
24 VDC
Pin No.2
Input n+1
Pin No.3
0 VDC
Pin No.4
Input n
Pin No.5
N.C.

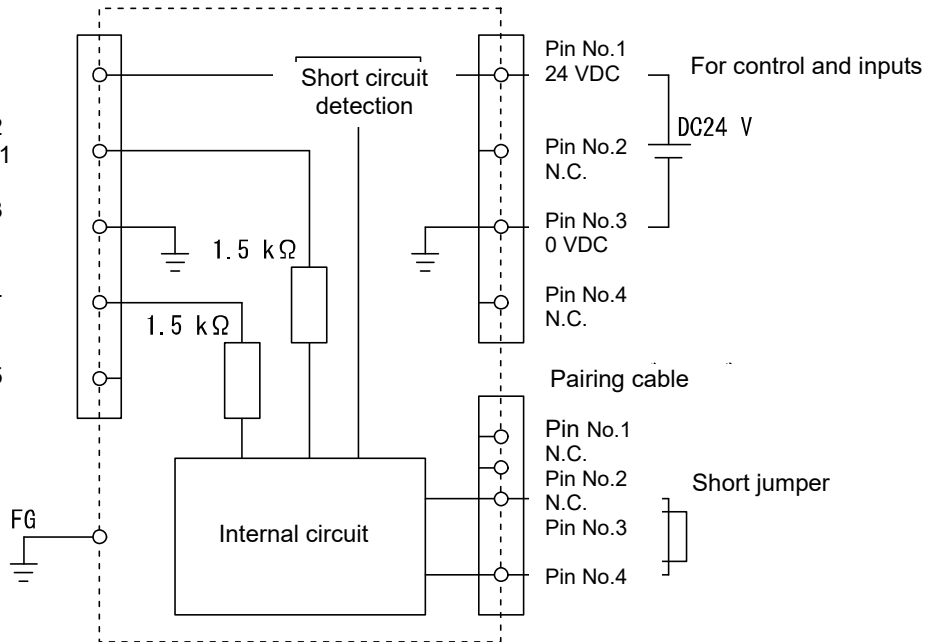

Output unit

- Pairing cable: M12 4-pin plug (male)

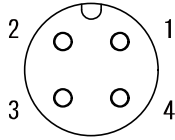

Pin number	Description signal
1	Connector the short jumper connector - When connected: Normal operation mode - When not connected: Pairing mode
2	
3	
4	

Mating connector : M12 4-pin socket A code

- Pairing supply cable: M12 4-pin plug (male)

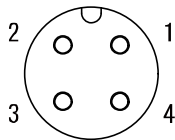

Pin number	Description signal
1	24 V (for control and input)
2	24 V (for output)
3	0 V (for control and input)
4	0 V (for output)

Mating connector : M12 4-pin socket A code

- Output cable : M12 5-pin socket (female)



Pin number	Description signal
1	N.C.
2	Output n+1
3	0 V (for output)
4	Output n
5	N.C.

Mating connector : M12 4-pin (Plug) A code, M12 5-pin (plug) A code

- Output unit circuit

Output cable x 8 (0 to F)

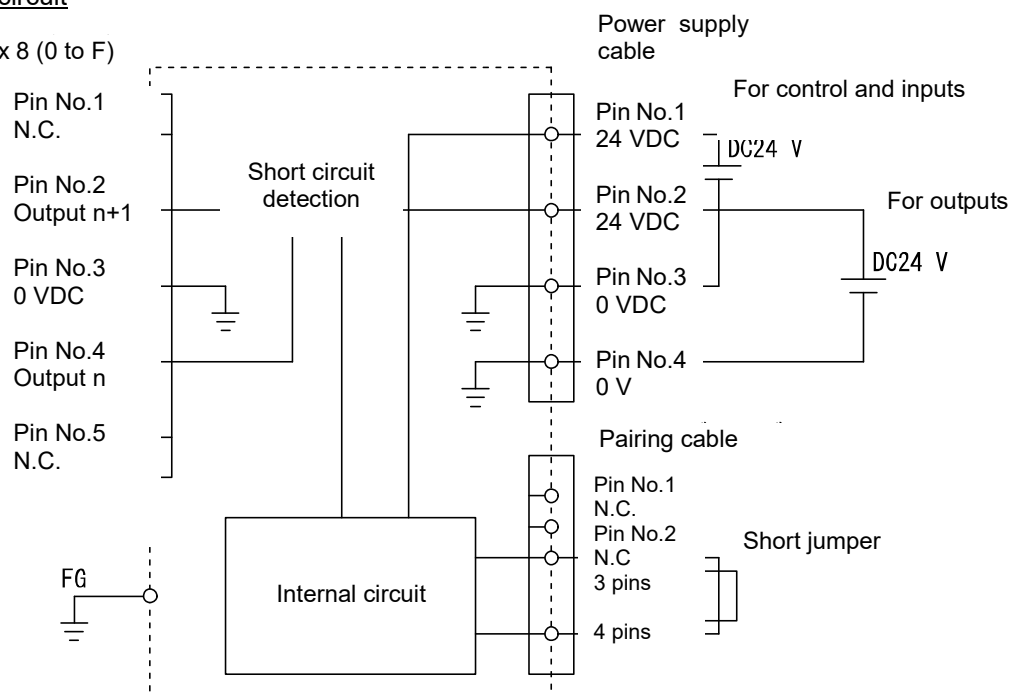

LED

■ Remote e-CON type LED indicator

Input unit

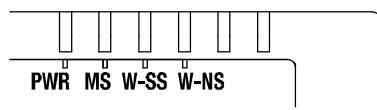

Remote e-CON input type LED indicator

- Remote e-CON input type LED indicator specifications

LED name	Function	Color of LED	Single Operation
PWR	Status of power supply voltage for control	Green LED is ON.	Normal power supply voltage for control and input (US1) ON
		OFF	Power supply for control and input (US1) is not supplied.
10ms	Status of remote input	Green LED is ON.	Operating normally
		Red LED flashes.	Restorable error is detected. Short-circuit detection of power supply for control / input
		Red LED flashes.	Abnormal power supply voltage for control and input (US1) (Applicable when the power supply voltage monitor is enabled)
		Red LED is ON.	Unrecoverable error is detected.
		OFF	Power supply for control and input (US1) is not supplied.
W-SS	Radio wave receiving intensity	Green LED is ON.	Received radio wave intensity level 3
		Green LED flashes (1 Hz)	Received radio wave intensity level 2
		NS: Green LED flashes (2Hz)	Received radio wave intensity level 1
		Red LED flashes.	Wireless communication is not connected.
		OFF	Not registered
W-NS	Wireless communication connection status	Green LED is ON.	Remote input (RY)
		Red LED flashes.	Remote input not connected
		Red LED is ON.	Remote input not connected (Non-restorable error in wireless communication)
		Red/green	Wireless communication connection is under construction.
		Orange LED flashes.	Pairing operation is in progress
		OFF	Base not connected

* If there are multiple conditions for LED ON/Flashing, the detailed information can be seen only when the setting of the diagnostic information is "Simple" or "Detailed".

Output unit

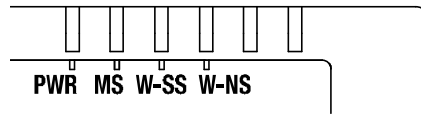

Remote e-CON output type LED indicator

- Remote e-CON output type LED indicator specifications

LED name	Function	Color of LED	Single Operation
PWR	Indicates the power supply voltage (US1/ US2) status	Green LED is ON.	Normal power supply voltage for control and input (US1) ON, and normal power supply voltage level for output (US2)
		Red LED flashes.	Abnormal power supply voltage level for output (US2) (Applicable when the power supply voltage monitor is enabled)
		OFF	Power supply for control and input (US1) is not supplied.
MS	Status of remote output	Green LED is ON.	Operating normally
		Red LED flashes.	Restorable error is detected. - Short-circuit detection of output load
		Red LED flashes.	Abnormal power supply voltage for control and input (US1) (Applicable when the power supply voltage monitor is enabled)
		Red LED is ON	Unrestorable error is detected.
		OFF	Power supply for control and input (US1) is not supplied.
W-SS	Radio wave receiving intensity	Green LED is ON.	Received radio wave intensity level 3
		Green LED flashes (1Hz)	Received radio wave intensity level 2
		Green LED flashes (2Hz)	Received radio wave intensity level 1
		Red LED flashes.	Wireless communication is not connected.
		OFF	Base not registered
W-NS	Wireless communication connection status	Green LED is ON.	Remote output connected correctly
		Red LED flashes.	Remote output not connected
		Red LED is ON	Remote output not connected (Non-restorable error in wireless communication)
		Red/green	Wireless communication connection is being configured (pairing)
		Orange LED is ON	Forced output mode is ON
		Orange LED flashes.	Pairing operation is in progress
		OFF	Base is not connected

* If there are multiple conditions for LED ON/Flashing, the detailed information can be seen only when the setting of the diagnostic

information is "Simple" or "Detailed".

■ Remote grommet type LED indicator

Input unit

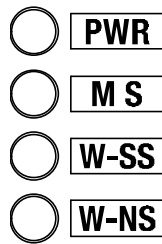

Remote grommet input type LED indicator

- Remote grommet input type LED indicator specifications

LED name	Function	Color of LED	Single Operation
PWR	Indicates the power supply voltage (US1) status	Green LED is ON.	Normal power supply voltage for control and input (US1) ON
		OFF	Power supply for control and input (US1) is not supplied.
MS	Status of remote input	Green LED is ON.	Operating normally
		Red LED flashes.	Restorable error is detected. - Short-circuit detection of power supply for control / input - Abnormal power supply voltage for control and input (US1) (Applicable when the power supply voltage monitor is enabled)
		Red LED is ON	Unrestorable error is detected.
		OFF	Power supply for control and input (US1) is not supplied.
W-SS	Radio wave receiving intensity	Green LED is ON.	Received radio wave intensity level 3
		Green LED flashes (1Hz)	Received radio wave intensity level 2
		Green LED flashes (2Hz)	Received radio wave intensity level 1
		Red LED flashes.	Wireless communication is not connected.
		OFF	Base not registered
W-NS	Wireless communication connection status	Green LED is ON.	Remote input is connected correctly
		Red LED flashes.	Remote input not connected
		Red LED is ON	Remote input not connected (Non-restorable error in wireless communication)
		Red/green	Wireless communication connection is being configured (pairing)
		OFF	Base not connected

* If there are multiple conditions for LED ON/Flashing, the detailed information can be seen only when the setting of the diagnostic information is "Simple" or "Detailed".

Output unit

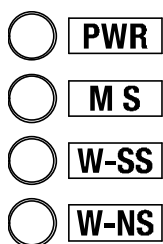

Remote grommet output type LED indicator

- Remote grommet output type LED indicator specifications

LED name	Function	Color of LED	Single Operation
PWR	Indicates the power supply voltage (US1/US2) status	Green LED is ON.	Normal power supply voltage for control and input (US1) ON, and normal power supply voltage level for output (US2)
		Red LED flashes.	Abnormal power supply voltage level for output (US2) (Applicable when the power supply voltage monitor is enabled)
		OFF	Power supply for control and input (US1) is not supplied.
MS	Status of remote output	Green LED is ON.	Operating normally
		Red LED flashes.	Restorable error is detected. - Short-circuit detection of output load - Abnormal power supply voltage for control and input (US1) (Applicable when the power supply voltage monitor is enabled)
		Red LED is ON	Unrestorable error is detected.
		OFF	Power supply for control and input (US1) is not supplied.
W-SS	Radio wave receiving intensity	Green LED is ON.	Received radio wave intensity level 3
		Green LED flashes (1Hz)	Received radio wave intensity level 2
		Green LED flashes (2Hz)	Received radio wave intensity level 1
		Red LED flashes.	Wireless communication is not connected.
		OFF	Base not registered
W-NS	Wireless communication connection status	Green LED is ON.	Remote output connected correctly
		Red LED flashes.	Remote output not connected
		Red LED is ON	Remote output not connected (Non-restorable error in wireless communication)
		Red/green	Wireless communication connection is being configured (pairing)
		Orange LED is ON	Forced output mode is ON
		OFF	Base not connected

* If there are multiple conditions for LED ON/Flashing, the detailed information can be seen only when the setting of the diagnostic information is "Simple" or "Detailed".

Setting and Adjustment

■Flow chart for using the wireless system

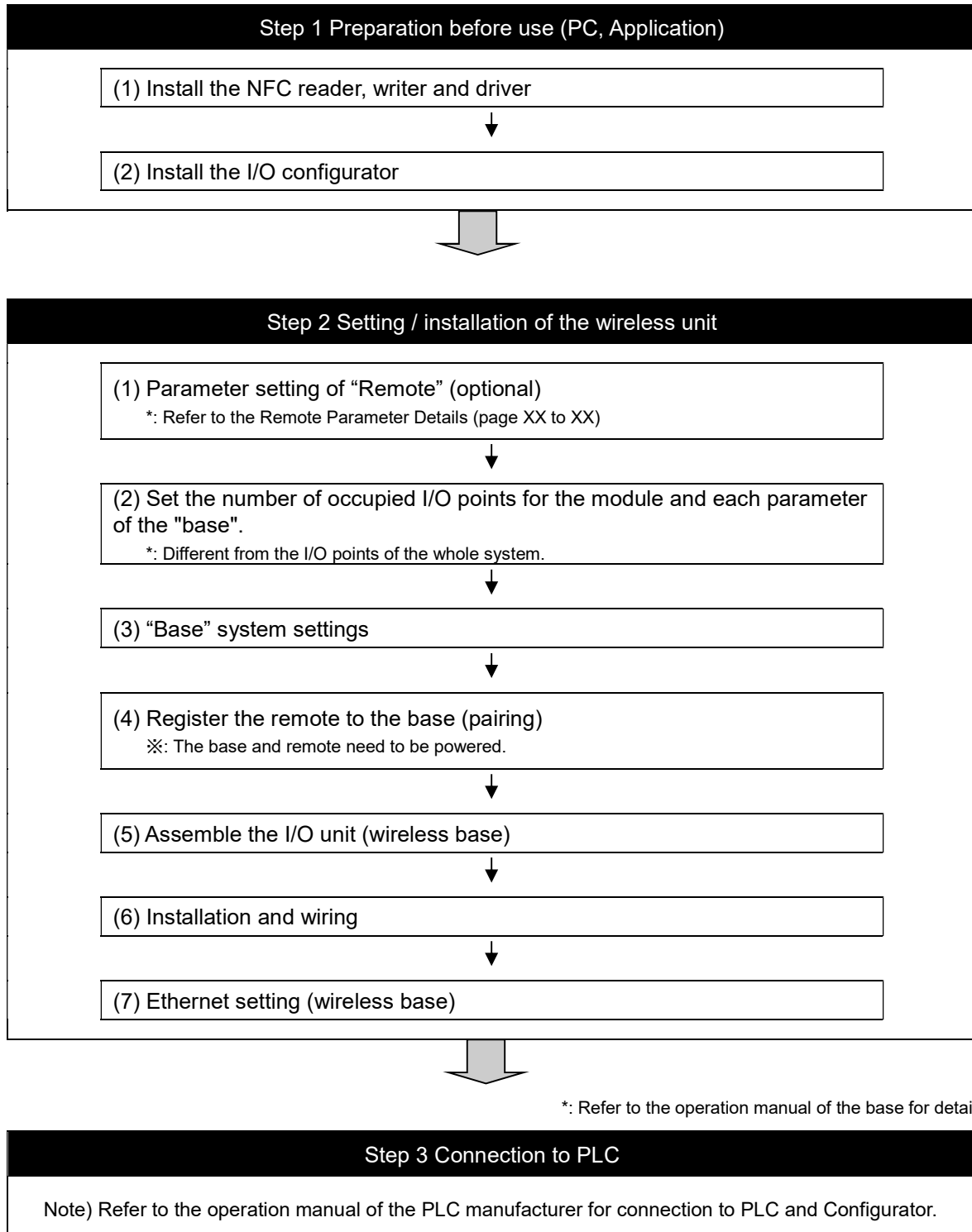

With the above settings, it is possible to control the upper level controller.

Refer to the operation manual for each manufacturer for how to set the controller and the PLC.

Refer to the operation manual for the I/O Configurator (NFC version) for details of the SMC wireless system I/O Configurator.

■Procedure 1 Preparation (PC application)

SMC wireless system I/O Configurator (NFC version)

The I/O Configurator (NFC version) can be used to check the parameter setting of the wireless unit and the contents and status of the constructed wireless system, using an NFC reader / writer and a PC.

There are two types of settable parameters which can be read or written **when no power is supplied to the product** and the parameters which can be read or written **only when the power is supplied to the product**.

The figure below shows the image of connected I/O Configurator (NFC version) and wireless unit.

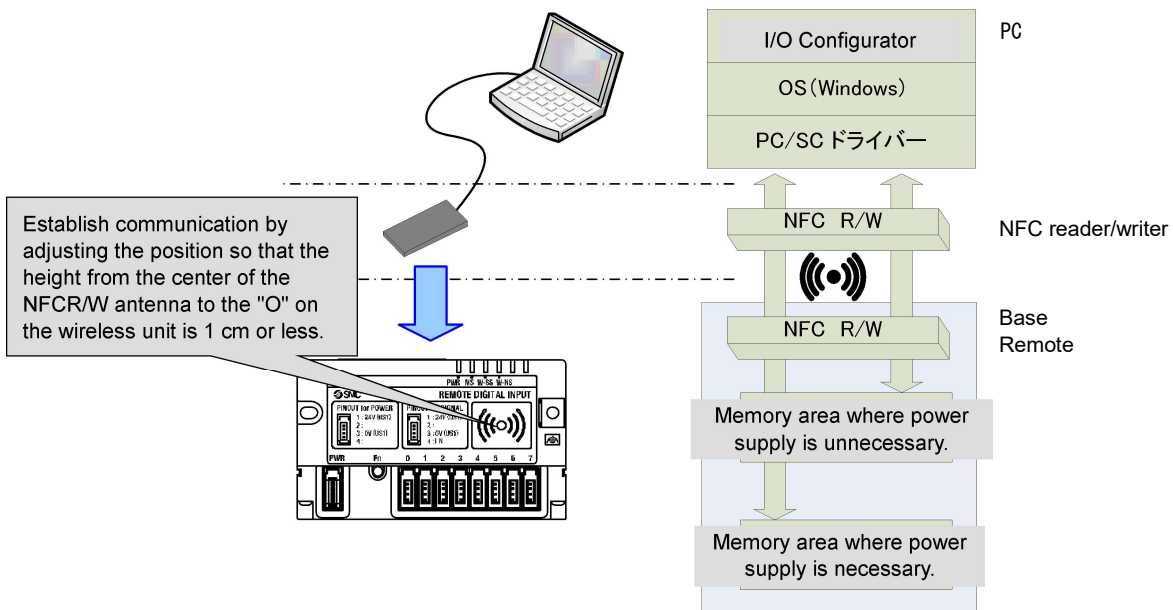

Connected I/O Configurator (NFC version) and wireless unit.

In order to use the I/O Configurator (NFC version), it is necessary to install a driver etc. in advance and set the NFC reader / writer on the computer.

Refer to the operation manual for the I/O Configurator (NFC version) for details of the I/O Configurator (NFC version).

*: Communication timing

The NFC communication is not accessed all the time. Therefore, it is necessary to update the contents displayed on the screen by clicking the "Refresh button" when reading the parameters. The changed parameters are enabled after the product is powered on or by pressing the reset button on the I/O configurator screen. As the parameter setting requires time for settlement, do not turn off the power supply for 2 seconds.

*: To change module to be set

As the settings between the base and remote are different, it is necessary to update the displayed parameter by clicking the "Refresh button" on the screen of the I/O Configurator after changing the unit in which the parameters are to be set.

*: Operation already checked. NFC reader / writer

Refer to the operation manual for the I/O Configurator (NFC version).

I/O Configurator (NFC version)

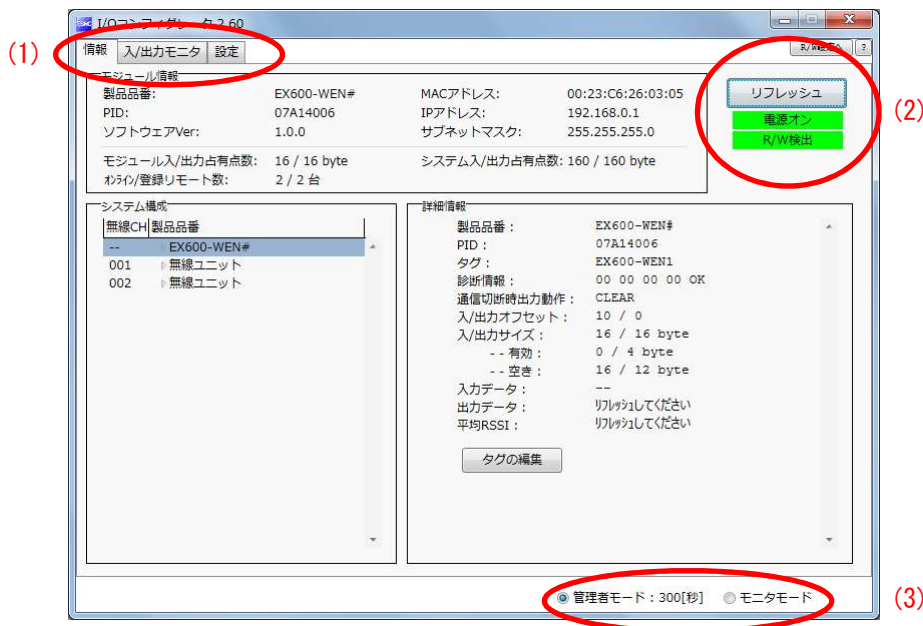

(1) I/O Configurator (NFC version) consists of 3 tabs listed below.

Information tab

- The unit information area indicates the unit information.
- System configuration: Displays the configuration information of the base and remote (connected unit)
- The system configuration of only the wireless master unit is shown in a tree-like profile.
- Detailed information: shows detailed information about the unit selected in the system configuration.

I/O monitor tab

- Input tab shows the input map information of the wireless unit.
- Output tab shows the output map information of the wireless unit.

Set tab

- Set item: Set the parameters required to operate the base/ remote.

*: The contents of the setting tab is different between the base and remote.

Refer to the wireless system parameter list for details.

(2) The function of the upper right button of the "I/O Configurator (NFC)" is described below.

Refresh button

- Clicking the refresh button while holding the NFC reader / writer to the base / remote can reflect the setting of the base / remote on the I/O Configurator screen.

Power supply ON / OFF button

- "Power supply ON" is displayed when power is supplied to the base / remote, and "Power supply OFF" is displayed when power is not supplied.

R/W detection / R/W no-detection button

- When the NFC reader / writer (R/W) is inserted into the USB port of the PC and the PC detects the NFC reader and writer, "R/W detection" is displayed. When the PC cannot detect it, "R/W not-detected" is displayed.

NFC setting button

- When the NFC setting button is clicked, "NFC port / PaSoRi" is displayed on the setting screen.

(3) The I/O Configurator has two modes: a supervisor mode which can change the parameter setting and a monitor mode which can only read the parameters.

It is necessary to change the mode to the Administrator mode to set the parameters.

Administrator mode: available to read and write the parameters.

Monitor mode: available to read the parameters only. Writing parameters is not available.

Enter the correct password to enter administrator mode.

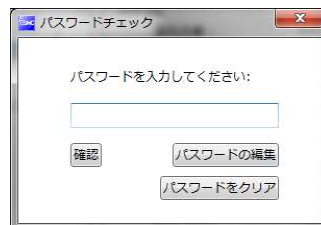

Default password : admin

If the password is forgotten, use the [Clear password] function. When the [Clear password] button is pressed, the password clear window will appear. The password will be cleared when master factory key is entered. Then it is possible to enter administrator mode without inputting the password.



Master key: ADMIN

A password can be set using the supervisor mode to prevent mischievous action by others. It is recommended to change the default password at the time of first access.

■ Procedure 2 Setting / Installing the wireless unit

Wireless system parameter list

- Remote (input / output) setting parameters

Classification	Parameter name	Set value	Initial value	Setting when not energized	Notes
Setting	a) Output while communication is not established	CLEAR/HOLD	CLEAR	Available	Setting the output operation while the fieldbus communication is disconnected.
	b) Wireless communication	Active/Idle	Active	Available	If it is set to "Idle", the wireless communication is disconnected.
Information	TAG	Max. 15 characters	Product number	Available	Letters which can be input are half-width characters (alphabets, numbers, symbols) that correspond to ASCII code. Writing from the base to the remote is not possible during a non-energized state.

Remote Parameter Details

The following two settings need to be performed to set the parameters of the remote.

- (1) Remote setting
- (2) Pairing setting

(1) Remote setting

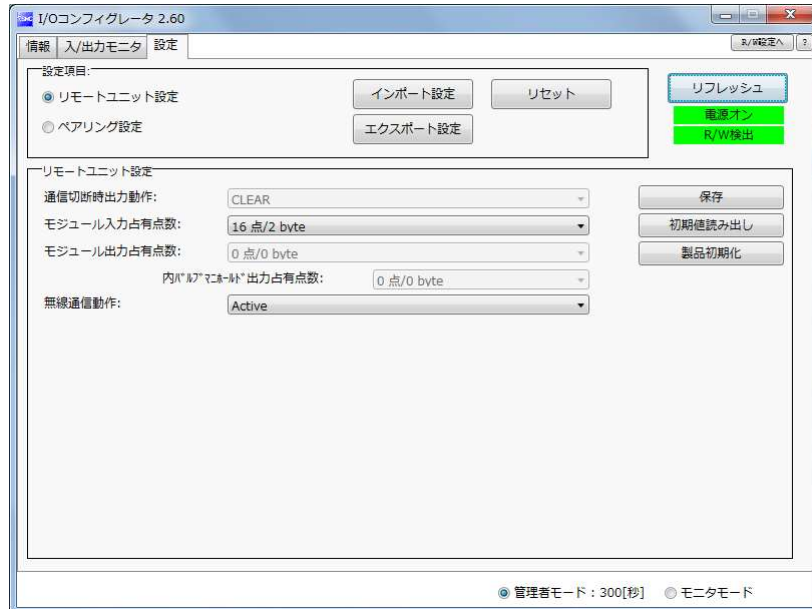

- Output while communication is not established
Define all settings in the output operation status when the fieldbus communication is disconnected.
Clear: Clear the output.
Hold: Fix the output at the current value.
- Wireless communication
If it is set to "Idle", the wireless communication is disconnected.

(2) Pairing setting

Setting for wireless communication between the base and remote.

The required setting for wireless registration of the remote is Pairing (change of operation mode) only.

After changing the operation mode in the pairing setting, the mode is changed by clicking the **Reset** button or re-supplying power so that the mode will be changed to the base registration or listing for connection.

*: After switching the operation mode with the Pairing setting, check that the W-NS LED on the remote unit flashes in green and red alternately.

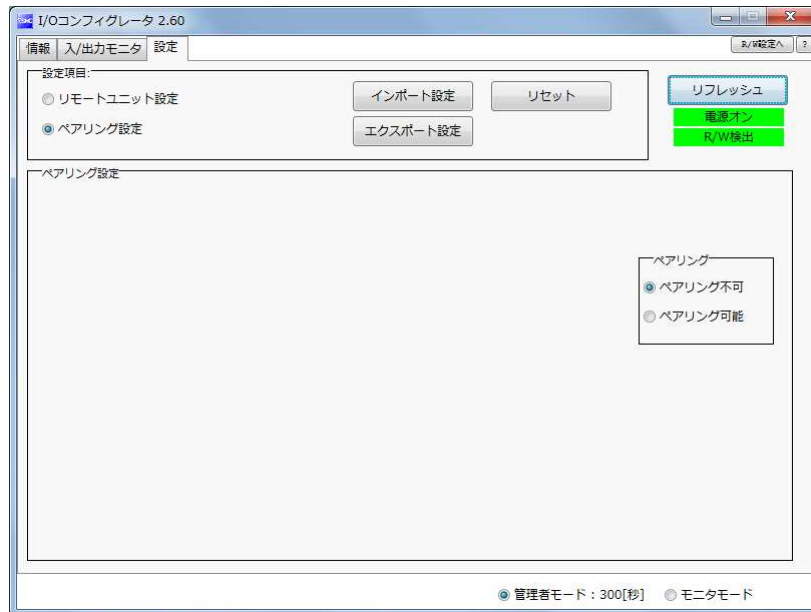

a) Pairing

Select the operation mode of the remote.

The base can be registered only when "Pairing enable" is selected.

Pairing disable: Remote cannot be registered (communication with the registered remote will be established).

Pairing enable: Remote can be registered.

Remote registration

Registration for wireless communication between the base and remote.

For this wireless system, it is necessary to register the PID (Product ID) of each product to establish communication without interference from another network.

The minimum required settings for registration of the base are pairing (change of operation mode) and remote registration.

Register the dummy remote as necessary.



- After changing the operation mode in the pairing setting, the mode is changed by clicking the **Reset** button or re-supplying power so that the mode will be changed to the remote registration or listing for connection.

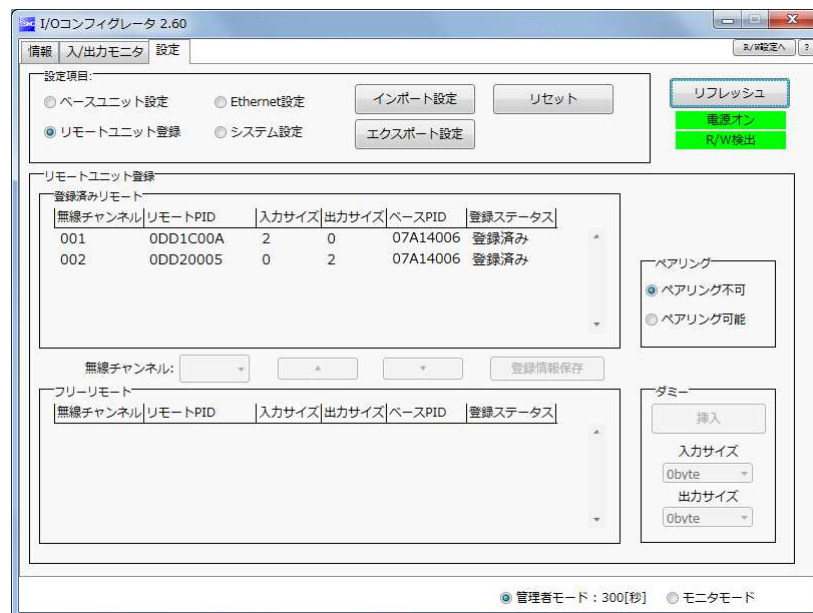

- Pairing

Select the operation mode of the base.

The remote can be registered only when "Pairing enable" is selected.

Pairing disable: Remote cannot be registered (communication with the registered remote will be established).

Pairing enable: Remote and dummy remote can be registered.

When pairing is enabled, operation control of the registered remote cannot be performed through communication.

- Remote registration

Register and delete the base to/from the remote; and check the registration status of the remote.

Refer to Wireless slave unit registration procedure for details.

- Dummy remote

Register the dummy remote to the base.

Refer to the Wireless unit registration procedure

Wireless unit registration procedure

- Registration procedure for the base and remote

(1) **Change of operation mode** of the remote

(1) e-CON type

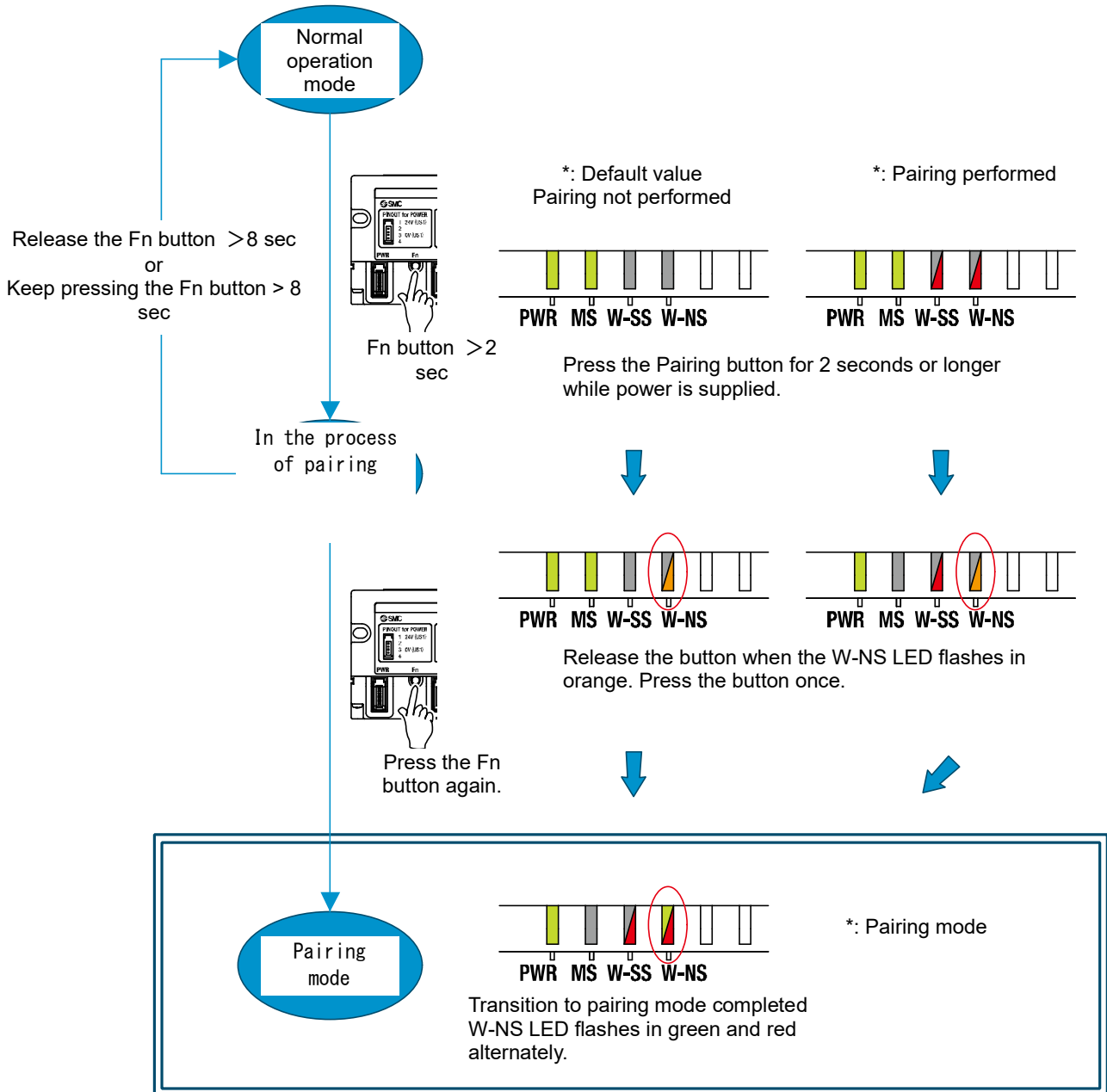

Because of the button, remote e-CON type does not require the NFC.
Operation mode change for the base is necessary.

(2) Grommet type

1. Disconnect the power connector and turn off the power.

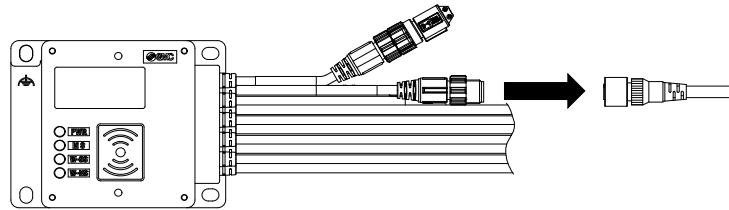

2. Disconnect the short jumper connector for the pairing cable.

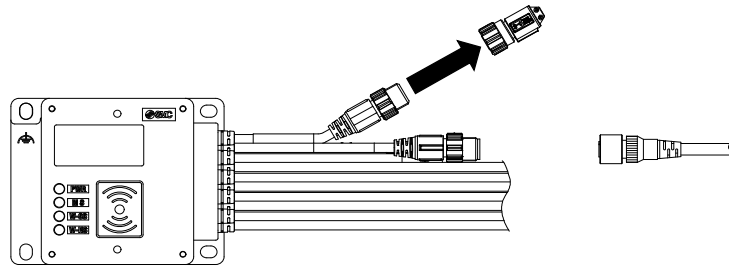

3. Connect the power connector again to turn on the power.

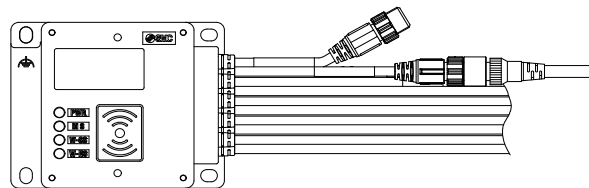

By following this procedure, the remote grommet type does not require the NFC. Operation mode change for the base is necessary.

(2) **Change of operation mode** of the base.

Enable the pairing setting of the remote registration on the base and reflect the change by clicking the **Reset** button or by re-supplying power. Then, update the contents on the screen by clicking the **Refresh** button.

(The remote information that can be registered is displayed in the Free remote area)

(3) Select the wireless channel

Register the required wireless channel by registering the remote on the base. Select the remote and move it from the Free Remotes box to the Registered Remotes box.

(Registration is not complete at this point. The status of the remote will be shown as "Waiting for registration").

(4) **Determination of the registered information**

Press the Save reg-info to register the remote to the base.

Then, click **Refresh all** to confirm that the setting has been reflected.

(When the remote is registered correctly, the status of the selected remote will change from "Waiting for registration" to "Registered".

(When the remote e-CON type is registered correctly, the mode will change automatically).

(5) **Change of operation mode** of the base.

Change the pairing setting on the remote registration screen of the base to "Pairing disable" and reflect the change by clicking **Reset module** or by re-supplying power.

(6) Change of the normal mode of the grommet type remote

1. Disconnect the power connector and turn off the power.

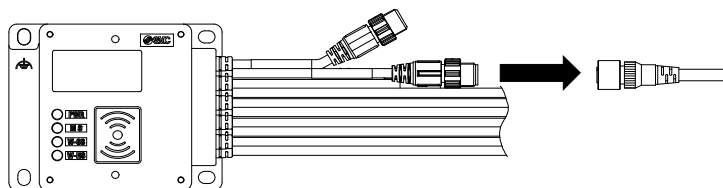

2. Connect the short jumper connector for the pairing cable.

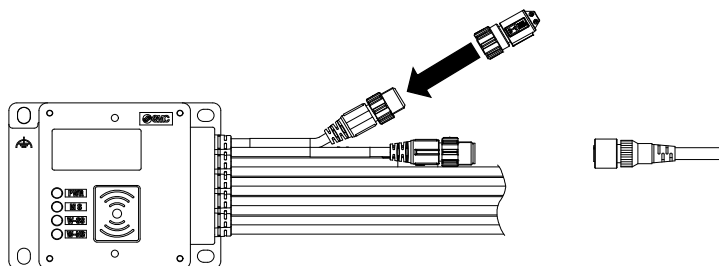

3. Connect the power connector again to turn on the power.

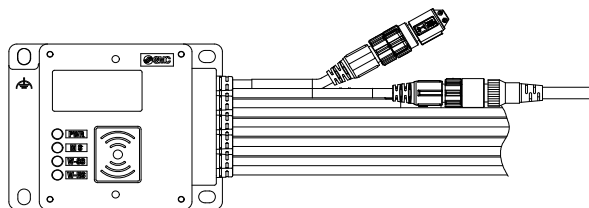

Now, the registration procedure for the base and remote is complete.

When registering more than one remote is required, repeat procedures (3) and (4).

It is also possible to register more than one remote simultaneously to the base.



- Registration should be performed with power supplied to both the base and remote.
- **For the Input size and Output size of the remote, the setting of wireless registration will be reflected to the base.**
 - When changing the number of Input and Output points of the remote, **pairing should be performed again.**
- The setting of the Input and Output points of the wireless base is valid all the time. Be careful that the I/O map will be different if the setting is changed after constructing the I/O map. After changing, the setting is reflected by pressing the [Reset] button or by supplying the power again.
- For the grommet type, the mode is not changed automatically even when the registration completes correctly.
 - Turn on the power again with the pairing cable connected with the short jumper.

Dummy remote

The dummy remote can register a "Dummy area" in the I/O map. A remote can be added without changing the I/O map by registering the remote to the "Dummy area" even after system construction.

The remote allocation order to the I/O map is from the smallest channel to the largest channel registered by the wireless channel which has been set during remote.

At the time, the wireless channel in which no remote is registered will be ignored.

When adding a new remote, it may be required to change the I/O map depending on the wireless channel number.

The dummy remote can be registered only with the base unit.



- To reserve the dummy remote registration, it is necessary to set the number of inputs / outputs. If a remote with inputs / outputs which are different from the set numbers is registered, the I/O map should be changed.

Dummy remote

(1) **Change of operation mode** of the base

Enable the pairing setting of the remote registration of the base and reflect the change by clicking **Reset module** or by re-supplying power. Then, update the contents on the screen by clicking the **Refresh** button.

(2) **Inputs / outputs setting** of dummy remote

Set the number of inputs and outputs of the dummy remote.

(3) Allocation of the dummy remote to the **required wireless channel**

Select the required wireless channel and click **Insert** so that the set dummy remote is displayed in the box for "Registered remotes".

(Dummy remote registration is not complete at this point. The status is "Waiting for registration".)

(4) Determination of dummy remote **registration information**

Click the **Save reg-info** to reflect the registered information.

(When registration has been completed successfully, the status of the dummy remote will change to "registered".)

Now, the registration procedure for the dummy remote is complete.

Dimensions

○EX600-WD□E1

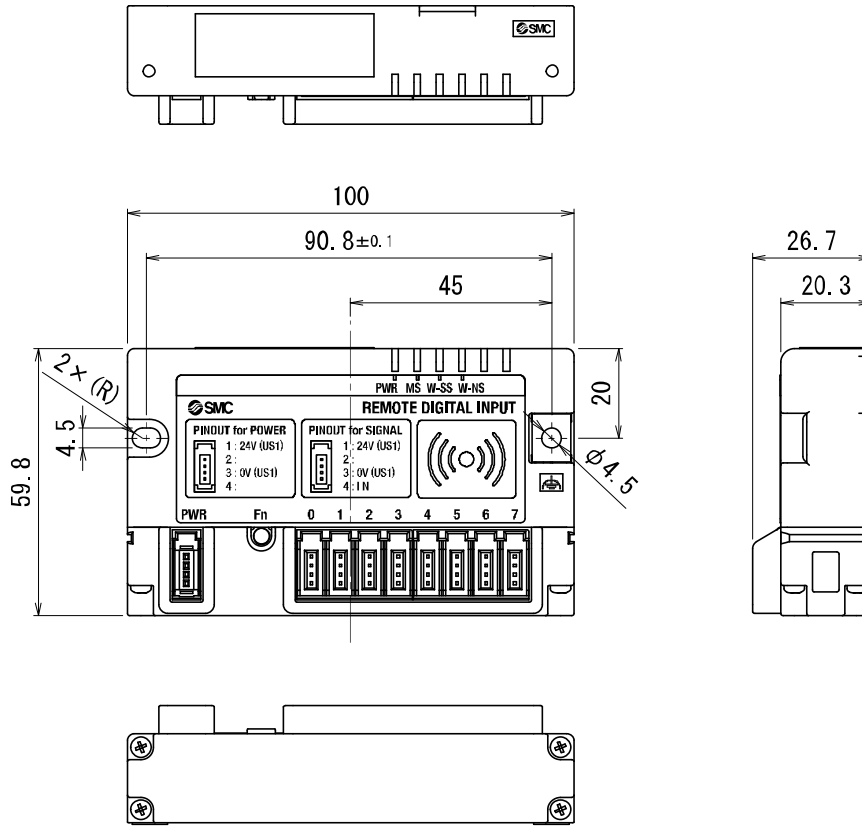

○EX600-WD□A1

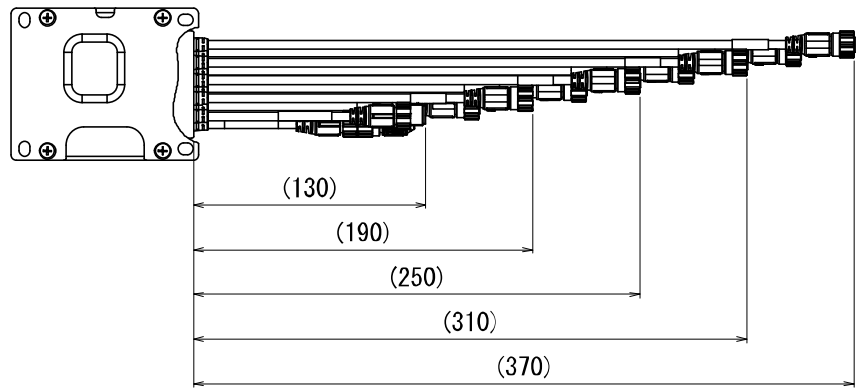
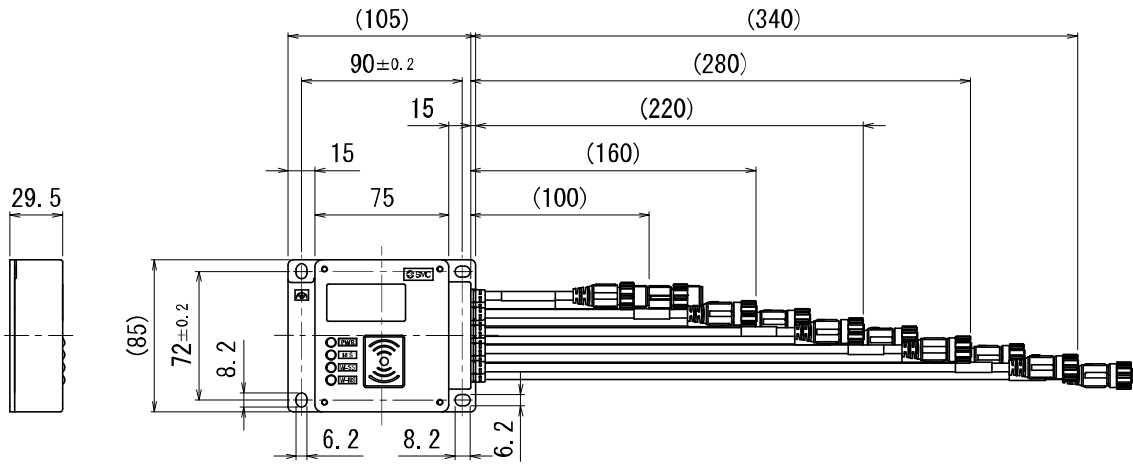

Specifications

Input unit (e-CON type) specifications

Electrical specifications

Items		Specifications
Power supply for control and input (US1)		24 VDC +/-10%
Current consumption		100 mA or less
Input specification	Control point	1 connector
	Shaft type	PNP(-COM)
	Connector type	e-CON (4 pins)
	Max. supply current for sensor	0.3 A/ connector 2 A / unit
	Input resistance	1.5 kΩ
	Rated input current	5 mA
	Criteria	OFF voltage/current
	ON voltage/current	15 VDC or more / 5 mA or more
Protection		Built-in short circuit prevention

General specifications

Items		Specifications
Enclosure rating		IP20
Cable tensile force		10 N
Ambient operating temperature		0 to +50 °C
Ambient storage temperature		-10 to +60 °C
Ambient humidity		35 to 85% RH (no condensation)
Withstand voltage		500 VAC-1 minute between external terminals and metallic parts
Insulation resistance		10 MΩ or more (500 VDC between external terminals and metallic parts)
Vibration resistance		EN61131-2 compliant 5 ≤ f < 8.4 Hz 3.5 mm 8.4 ≤ f < 150 Hz 9.8 m/s ²
Impact resistance		EN 61131-2 compliant, 147 m/s ² , 11 ms
Mounting orientation:		Through hole for M4 screw (2 pcs.)
Weight		130 g (body only)

Wireless communication specifications

Items		Specifications
Protocol		SMC original protocol
Radio wave type		Frequency Hopping Spread Spectrum (FHSS)
Frequency		2.4 GHz (2403 to 2481 MHz)
Frequency channel		79 ch (Bandwidth: 1.0 MHz)
Communication speed		250 kbps
Communication distance		Within 10 m (depending on the operating environment)
Radio Law certificate		Construction design certificate (in Japan)

NFC communication specifications

Items	Specifications
Communication standard	ISO / IEC 14443B (Type-B)
Frequency	13.56 MHz
Communication distance	~1 cm

*: The NFC communication RFID tag of the 13.56 MHz passive type.

Remote (input / output) setting parameters

Classification	Parameter name	Initial value
Remote unit setting	Occupied points for the module input	16 points (2 byte)
	Wireless communication	Active
	Tag	Product number

※: Input: 16 points (2 bytes) fixed, only upper 1 byte is valid.

*: Input status is maintained while wireless communication is disconnected.

Output unit (e-CON type) specifications

Electrical specifications

Items	Specifications	
Power supply for control and input (US1)	24 VDC +/-10%	
Current consumption	50 mA or less	
Output power supply voltage (US2)	24 VDC +/-10%	
Output specification	Number of points	8 points (1 point / connector)
	Output type	PNP (–COM)
	Connector type	e-CON (4 pins)
	Maximum load current	100 mA / point
	(Protection)	Built-in short circuit prevention

General specifications

Items	Specifications
Enclosure rating	IP20
Cable tensile force	10 N
Ambient operating temperature	0 to +50 °C
Ambient storage temperature	–10 to +60 °C
Ambient humidity	35 to 85% RH (no condensation)
Withstand voltage	500 VAC-1 minute between external terminals and metallic parts
Insulation resistance	10 MΩ or more (500 VDC between external terminals and metallic parts)
Vibration resistance	EN61131-2 compliant $5 \leq f < 8.4$ Hz 3.5 mm $8.4 \leq f < 150$ Hz 9.8 m/s ²
Impact resistance	EN 61131-2 compliant, 147 m/s ² , 11 ms
Mounting	Through hole for M4 screw (2 pcs.)
Weight	130g (body only)

Wireless communication specifications

Items	Specifications
Protocol	SMC original protocol
Radio wave type	Frequency Hopping Spread Spectrum (FHSS)
Frequency	2.4 GHz (2403 to 2481 MHz)
Frequency channel	79 ch (Bandwidth: 1.0 MHz)
Communication speed	250 kbps
Communication distance	Within 10 m (depending on the operating environment)
Radio Law certificate	Construction design certificate (in Japan)

NFC communication specifications

Items	Specifications
Communication standard	ISO / IEC 14443B (Type-B)
Frequency	13.56 MHz
Communication distance	Up to 1 cm

*: The NFC communication RFID tag of the 13.56 MHz passive type.

Remote (input / output) setting parameters

Items	Parameter name	Initial value
Remote unit setting	Hold / Clear (unit)	Clear
	Occupied points for the module output	16 points (2 byte)
	Wireless communication	Active
	Tag	Product number

※: Output: 16 points (2 bytes) fixed, only upper 1 byte is valid.

*: Output status is maintained while wireless communication is disconnected.

Input unit (grommet type) specifications

Electrical specifications

Items		Specifications	
Power supply for control and input (US1)		24 VDC +/-10%	
Current consumption		100 mA or less	
Input specification	Number of points	16 points (2 points / connector)	
	Output type	PNP (-COM)	
	Connector type	M12 5-pin socket	
	Max. supply current for sensor	0.3 A/ connector 2 A / unit	
	Input resistance	1.5 kΩ	
	Rated input current	5 mA	
	Criteria	OFF voltage/ OFF current	5 VDC or less / 2 mA or less
		ON voltage/ ON current	15 VDC or more / 5 mA or more
(Protection)		Built-in short circuit prevention	

General specifications

Items	Specifications
Enclosure rating	IP67
Cable tensile force	100 N
Ambient operating temperature	0 to +50 °C
Ambient storage temperature	-10 to +60 °C
Ambient humidity	35 to 85% RH (no condensation)
Withstand voltage	500 VAC-1 minute between external terminals and metallic parts
Insulation resistance	10 MΩ or more (500 VDC between external terminals and metallic parts)
Vibration resistance	EN 61131-2 compliant 5 ≤ f < 8.4 Hz 3.5 mm 8.4 ≤ f < 150 Hz 9.8 m/s ²
Impact resistance	EN 61131-2 compliant, 147 m/s ² , 11 ms
Mounting	Through hole for M5 screw (4 pcs.)
Weight	480 g

Wireless communication specifications

Items	Specifications
Protocol	SMC original protocol (SMC encryption)
Radio wave type (spread)	Frequency Hopping Spread Spectrum (FHSS)
Frequency	2.4 GHz (2403 to 2481 MHz)
Frequency channel	79 ch (Bandwidth: 1.0 MHz)
Communication speed	250 kbps
Communication distance	Within 10 m (depending on the operating environment)
Radio Law certificate	Construction design certificate (in Japan)

NFC communication specifications

Items	Specifications
Communication standard	ISO / IEC 14443B (Type-B)
Frequency	13.56 MHz
Communication distance	Up to 1 cm

*: The NFC communication RFID tag of the 13.56 MHz passive type.

Remote (input / output) setting parameters

Classification	Parameter name	Initial value
Remote unit setting	Occupied points for the module input	16 points (2 byte)
	Wireless communication	Active
	Tag	Product number

※: Input: 16 points (2 bytes) fixed, only upper 1 byte is valid.

*: Input status is maintained while wireless communication is disconnected.

Output unit (grommet type) specifications

Electrical specifications

Items	Specifications	
Power supply for control and input (US1)	24 VDC +/-10%	
Current consumption	50 mA or less	
Output power supply voltage (US2)	24 VDC +/-10%	
Output specification	Number of points	16 points (2 point / connector)
	Output type	PNP (-COM)
	Connector type	M12 5-pin socket
	Maximum load current	100 mA / point
	(Protection)	Built-in short circuit prevention

General specifications

Items	Specifications
Enclosure rating	IP67
Cable tensile force	100 N
Ambient operating temperature	0 to +50 °C
Ambient storage temperature	-10 to +60 °C
Ambient humidity	35 to 85% RH (no condensation)
Withstand voltage	500 VAC-1 minute between external terminals and metallic parts
Insulation resistance	10 MΩ or more (500 VDC between external terminals and metallic parts)
Vibration resistance	EN 61131-2 compliant $5 \leq f < 8.4$ Hz 3.5 mm $8.4 \leq f < 150$ Hz 9.8 m/s ²
Impact resistance	EN 61131-2 compliant, 147 m/s ² , 11 ms
Mounting	Through hole for M5 screw (4 pcs.)
Weight	480 g

Wireless communication specifications

Items	Specifications
Protocol	SMC original protocol (SMC encryption)
Radio wave type (spread)	Frequency Hopping Spread Spectrum (FHSS)
Frequency	2.4GHz (2403 to 2481MHz)
Frequency channel	79 ch (Bandwidth: 1.0 MHz)
Communication speed	250 kbps
Communication distance	Within 10 m (depending on the operating environment)
Radio Law certificate	Construction design certificate (in Japan)

NFC communication specifications

Items	Specifications
Communication standard	ISO/IEC14443B(Type-B)
Frequency	13.56 MHz
Communication distance	Up to 1 cm

*: The NFC communication RFID tag of the 13.56 MHz passive type.

Remote (input / output) setting parameters

Items	Parameter name	Initial value
Remote unit setting	Hold / Clear (unit)	Clear
	Occupied points for the module output	16 points (2 byte)
	Wireless communication	Active
	Tag	Product number

※: Output: 16 points (2 bytes) fixed, only upper 1 byte is valid.

*: Output status is maintained while wireless communication is disconnected.

Troubleshooting

When problems occur, take appropriate countermeasures while referring to the LED indication, troubleshooting and parameter settings.

If a cause applicable to the failure cannot be identified, this indicates that the equipment itself is broken. The fieldbus system damage can be caused by the operating environment. Contact SMC to obtain countermeasures.

- LED indication for remote input / output unit / Troubleshooting

LED	Details	Problem	No.
-	All LEDs are OFF.	-	See problem No. 1.
PWR	PWR(V) LED does not turn on green.	Red LED flashes.	See problem No. 2.
MS	MS LED does not turn on green.	Red LED flashes.	See problem No. 3.
		Red LED is ON	
		OFF	
W-SS	Red W-SS LED flashes or is OFF.	Red LED flashes.	See problem No. 4.
		OFF	
W-NS	W-NS LED does not turn on green.	Green LED flashes	See problem No. 5.
		Red LED flashes.	
		Red LED is ON	
		Orange LED is ON	
		Red and green LEDs are ON alternately.	
		OFF	
Digital input /output device does not operate correctly.			See problem No. 6.
Problems related to the NFC			See problem No. 7.

- Remote input unit / output unit / Troubleshooting

Problem No.	Phenomenon	Possible causes	Investigation and countermeasures
1	All LEDs are OFF.	Power supply for control is OFF.	Supply 24V DC +/-10% for control power source.
2	PWR: Red LED flashing	Output power supply voltage decreased	The power supply voltage for output has dropped. Check that a voltage of 24 VDC +/-10% is applied.
	PWR: OFF	Power supply voltage for control is not supplied	Supply 24V DC +/-10% for control power source.
3	MS: Red LED flashing	The following diagnostic information is detected. Remote Short-circuit of the power supply voltage for control Remote Power supply voltage for control decreased Short-circuit of output load	After checking the error contents while referring to the system diagnostic information and LED indication, refer to the following countermeasures. Check the remote wiring.
	MS: Red LED is ON	Remote malfunction	Replace the remote If the error is not restored after replacement, stop using the equipment and contact your SMC sales representative.
	MS: OFF	(1) Remote not registered (2) Remote power supply is OFF	(1) Check the registration status of the remote and perform pairing correctly. (2) Check that the power supply voltage for control is supplied to the remote.
4	W-SS: Red LED flashing	(1) Power supply for the base is OFF (2) Outside the wireless coverage area	(1) Check that the power supply voltage for control and input (US1) is supplied to the base and remote. (2) The distance which wireless communication between wireless systems can be established may have been exceeded. Reconsider the operating environment, such as the installation conditions of the base and remote.
	W-SS: OFF	(1) Remote not registered (2) Power for control is not supplied	(1) Check the registration status of the remote and perform pairing correctly. (2) Check that the power supply voltage for control is supplied to the remote.

Problem No.	Phenomenon	Possible causes	Investigation and countermeasures
5	W-MS: Red LED flashing	(1) Power supply for the base is OFF (2) Outside the wireless coverage area	(1) Check that the power supply voltage for control and input (US1) is supplied to the base and remote. (2) The distance which wireless communication between wireless systems can be established may have been exceeded. Reconsider the operating environment, such as the installation conditions of the base and remote.
	W-NS: Red LED is ON	No remotes are connected	Replace the remote If the error is not restored after replacement, stop using the equipment and contact your SMC sales representative.
	W-NS: Red / green LED	In pairing mode.	The system has been set to "Pairing enable". Change the setting to "Pairing disable" when pairing is not conducted. Check the registration status of the base. Turn on the power with the pairing connector is connected,
	W-NS: OFF	(1) Remote not registered (2) Power for control is not supplied	(1) Check the registration status of the remote and perform pairing correctly. (2) Check that the power supply voltage for control is supplied to the remote.

Problem No.	Phenomenon	Possible causes	Investigation and countermeasures
	Abnormal digital input device operation	Input type does not match.	If the polarities (PNP, NPN) of the remote and digital input unit do not match, replace one of them to make the combination match.
		Input power supply voltage for control decreased	Check that a voltage of 24 VDC \pm 10% is applied.
		Wiring or connection is defective.	Connect the wiring between the remote and the digital input equipment correctly.
		Remote	Replace the remote and check the operation.
		Digital input equipment broken	Replace the digital input equipment, and check the operation. Or, refer to Troubleshooting for the applicable digital input equipment.
6	Abnormal digital output equipment operation	Mismatched output type	If the polarities (PNP, NPN) of the remote and digital output unit do not match, replace one of them to make the combination match.
		Output power supply voltage decreased	Check if the PWR LED of the remote is turned ON in green. If it is OFF or a red LED flashes, supply a voltage of 24 VDC \pm 10% to the power supply for output.
		Wiring or connection is defective.	Connect the wiring between the remote and the digital output equipment correctly.
		Remote malfunction	Replace the remote with a normal one, and check the operation.
		Digital output equipment broken	Replace the digital output equipment, and check the operation. Or, refer to Troubleshooting for the applicable digital output equipment.
		Program error	Check that the ladder logic program works correctly.
7	NFC communication error	NFC communication is not established (communication failure)	Check the following items and check the operation again. - Confirm that the settings of the NFC port and PaSoRi of the PC are correct. - Check that the specifications of the NFC reader / writer to be used are appropriate. - Confirm that the NFC reader / writer are connected correctly. - The communication distance is outside of the NFC range. Place the body (area close to NFC antenna) close to the NFC reader / writer.
		NFC reader/writer broken	Replace the NFC reader / writer and check the operation. If the error is not restored after replacement, stop using the equipment and contact your SMC sales representative.

Accessories

- (1) Seal cap (10 pcs.)
EX9-AWTS



- (2) e-CON connector
ZS-28-□

Product No.	AWG No.	Conductor cross sectional area (mm SQ)	Wire O.D. (mm)	Color of cover
ZS-28-C-1	24 to 26	0.14 to 0.2	Ø1.0 to Ø1.2	Yellow
ZS-28-C-2			Ø1.2 to Ø1.6	Orange
ZS-28-C	22 to 20	0.3 to 0.5	Ø1.0 to Ø1.2	Green
ZS-28-C			Ø1.2 to Ø1.6	Blue
ZS-28-C-5	-	0.1 to 0.5	Ø1.6 to Ø2.0	Grey
ZS-28-CA-1			Ø0.6 to Ø0.9	Orange
ZS-28-CA-2			Ø0.9 to Ø1.0	Red
ZS-28-CA-3			Ø1.0 to Ø1.15	Yellow
ZS-28-CA-4			Ø1.15 to Ø1.35	Blue
ZS-28-CA-5			Ø1.35 to Ø1.6	Green