



Operation Manual

PRODUCT NAME

SMC Wireless System

MODEL / Series / Product Number

EX600-WPN# (Wireless master)

EX600-WSV# (Wireless slave)

SMC Corporation

Contents

Safety Instructions	2
SMC Wireless System Features	8
SMC Wireless System Outline	9
Outline	9
System configuration	10
Wireless master module	11
Wireless slave module	12
Definition and terminology	13
Assembly	15
Mounting and Installation	18
Installation	18
Model Indication and How to Order	21
Summary of Product Parts	22
Connector (Wireless master unit only)	23
LED Display	24
LED indication of wireless master unit	24
LED indication of wireless slave unit	26
Setting and Adjustment	27
Flow chart for using the wireless system	27
Setting	28
Dimensions	44
Hardware Configuration	46
GSDML file and icons	46
Configuration layout	46
Connection to SIEMENS PLC S7	47
I/O Map	56
I/O mapping order of wireless master / slave module	57
Diagnostic allocation	66
Detailed diagnostic data	67
Specifications	76
Troubleshooting	79
End Plate	
Model Indication and How to Order	95
Summary of Product parts	96
Mounting and Installation	98
Wiring	98
Specifications	100
Dimensions	101



Safety Instructions

These safety instructions are intended to prevent hazardous situations and/or equipment damage. These instructions indicate the level of potential hazard with the labels of "Caution", "Warning" or "Danger". They are all important notes for safety and must be followed in addition to International Standards (ISO/IEC)*1), and other safety regulations.

*1) ISO 4414: Pneumatic fluid power -- General rules relating to systems.
ISO 4413: Hydraulic fluid power -- General rules relating to systems.
IEC 60204-1: Safety of machinery -- Electrical equipment of machines .(Part 1: General requirements)
ISO 10218: Manipulating industrial robots -Safety.
etc.



Caution

Caution indicates a hazard with a low level of risk which, if not avoided, could result in minor or moderate injury.



Warning

Warning indicates a hazard with a medium level of risk which, if not avoided, could result in death or serious injury.



Danger

Danger indicates a hazard with a high level of risk which, if not avoided, will result in death or serious injury.

Warning

1. The compatibility of the product is the responsibility of the person who designs the equipment or decides its specifications.

Since the product specified here is used under various operating conditions, its compatibility with specific equipment must be decided by the person who designs the equipment or decides its specifications based on necessary analysis and test results.

The expected performance and safety assurance of the equipment will be the responsibility of the person who has determined its compatibility with the product.

This person should also continuously review all specifications of the product referring to its latest catalog information, with a view to giving due consideration to any possibility of equipment failure when configuring the equipment.

2. Only personnel with appropriate training should operate machinery and equipment.

The product specified here may become unsafe if handled incorrectly.

The assembly, operation and maintenance of machines or equipment including our products must be performed by an operator who is appropriately trained and experienced.

3. Do not service or attempt to remove product and machinery/equipment until safety is confirmed.

1. The inspection and maintenance of machinery/equipment should only be performed after measures to prevent falling or runaway of the driven objects have been confirmed.

2. When the product is to be removed, confirm that the safety measures as mentioned above are implemented and the power from any appropriate source is cut, and read and understand the specific product precautions of all relevant products carefully.

3. Before machinery/equipment is restarted, take measures to prevent unexpected operation and malfunction.

4. Contact SMC beforehand and take special consideration of safety measures if the product is to be used in any of the following conditions.

1. Conditions and environments outside of the given specifications, or use outdoors or in a place exposed to direct sunlight.

2. Installation on equipment in conjunction with atomic energy, railways, air navigation, space, shipping, vehicles, military, medical treatment, combustion and recreation, or equipment in contact with food and beverages, emergency stop circuits, clutch and brake circuits in press applications, safety equipment or other applications unsuitable for the standard specifications described in the product catalog.

3. An application which could have negative effects on people, property, or animals requiring special safety analysis.

4. Use in an interlock circuit, which requires the provision of double interlock for possible failure by using a mechanical protective function, and periodical checks to confirm proper operation.



Safety Instructions

Caution

1. The product is provided for use in manufacturing industries.

The product herein described is basically provided for peaceful use in manufacturing industries. If considering using the product in other industries, consult SMC beforehand and exchange specifications or a contract if necessary. If anything is unclear, contact your nearest sales branch.

Limited warranty and Disclaimer/Compliance Requirements

The product used is subject to the following "Limited warranty and Disclaimer" and "Compliance Requirements".

Read and accept them before using the product.

Limited warranty and Disclaimer

1. The warranty period of the product is 1 year in service or 1.5 years after the product is delivered, whichever is first.*2)

Also, the product may have specified durability, running distance or replacement parts. Please consult your nearest sales branch.

2. For any failure or damage reported within the warranty period which is clearly our responsibility, a replacement product or necessary parts will be provided.

This limited warranty applies only to our product independently, and not to any other damage incurred due to the failure of the product.

3. Prior to using SMC products, please read and understand the warranty terms and disclaimers noted in the specified catalog for the particular products.

***2) Vacuum pads are excluded from this 1 year warranty.**

A vacuum pad is a consumable part, so it is warranted for a year after it is delivered.

Also, even within the warranty period, the wear of a product due to the use of the vacuum pad or failure due to the deterioration of rubber material are not covered by the limited warranty.

Compliance Requirements

1. The use of SMC products with production equipment for the manufacture of weapons of mass destruction (WMD) or any other weapon is strictly prohibited.

2. The exports of SMC products or technology from one country to another are governed by the relevant security laws and regulation of the countries involved in the transaction. Prior to the shipment of a SMC product to another country, assure that all local rules governing that export are known and followed.

Operator

- ◆ This operation manual is intended for those who have knowledge of machinery using pneumatic equipment, and have sufficient knowledge of assembly, operation and maintenance of such equipment. Only those persons are allowed to perform assembly, operation and maintenance.
- ◆ Read and understand this operation manual carefully before assembling, operating or providing maintenance to the product.

■ Safety Instructions

Warning

- Do not disassemble, modify (including changing the printed circuit board) or repair.
An injury or failure can result.
- Do not operate or set with wet hands.
This may lead to an electric shock.
- Do not operate the product outside of the specifications.
Do not use for flammable or harmful fluids.
Fire, malfunction, or damage to the product can result.
Verify the specifications before use.
- Do not operate in an atmosphere containing flammable or explosive gases.
Fire or an explosion can result.
This product is not designed to be explosion proof.
- If using the product in an interlocking circuit:
 - Provide a double interlocking system, for example a mechanical system.
 - Check the product regularly for proper operation.Otherwise malfunction can result, causing an accident.
- The following instructions must be followed during maintenance:
 - Turn off the power supply.
 - Stop the air supply, exhaust the residual pressure and verify that the air is released before performing maintenance.Otherwise an injury can result.

Caution

- When handling the unit or assembling/replacing units:
 - Do not touch the sharp metal parts of the connector or plug for connecting units.
 - Take care not to hit your hand when disassembling the unit.
The connecting portions of the unit are firmly joined with seals.
 - When joining units, take care not to get fingers caught between units.
An injury can result.

- After maintenance is complete, perform appropriate functional inspections.
Stop operation if the equipment does not function properly.
Safety cannot be assured in the case of unexpected malfunction.

- Provide grounding to assure noise resistance of the Fieldbus system.
Individual grounding should be provided close to the product with a short cable.

Caution

Notice:

Changes or modifications not expressly approved by the manufacturer could void the user's authority to operate the equipment.

NOTE:

This equipment has been tested and found to comply with the limits for a Class A digital device, pursuant to Part 15 of the FCC Rules.

These limits are designed to provide reasonable protection against harmful interference when the equipment is operated in a commercial environment.

This equipment generates, uses, and can radiate radio frequency energy and, if not installed and used in accordance with the instruction manual, may cause harmful interference to radio communications.

Operation of this equipment in a residential area is likely to cause harmful interference in which case the user will be required to correct the interference at his own expense.

■ NOTE

- Follow the instructions given below when designing, selecting and handling the product.
 - The instructions on design and selection (installation, wiring, environment, adjustment, operation, maintenance, etc.) described below must also be followed.
 - *Product specifications
 - Use the specified voltage.
Otherwise failure or malfunction can result.
 - Reserve a space for maintenance.
Allow sufficient space for maintenance when designing the system.
 - Do not remove any nameplates or labels.
This can lead to incorrect maintenance, or misreading of the operation manual, which could cause damage or malfunction to the product.
It may also result in non-conformity to safety standards.
 - Beware of inrush current when the power supply is turned on.
Some connected loads can apply an initial charge current which will activate the over current protection function, causing the unit to malfunction.

● Product handling

*Installation

- Do not drop, hit or apply excessive shock to the SI unit.

Otherwise damage to the product can result, causing malfunction.

- Tighten to the specified tightening torque.

If the tightening torque is exceeded the mounting screws may be broken.

IP67 protection cannot be guaranteed if the screws are not tightened to the specified torque.

- If a large manifold valve is mounted, lift the unit so that stress is not applied to the connecting part while transporting.

The stress may cause breakage of the connecting part. The unit may become very heavy depending on the combination. Transportation/installation shall be performed by multiple operators.

- Never mount a product in a location that will be used as a foothold.

The product may be damaged if excessive force is applied by stepping or climbing onto it.

*Wiring

- Avoid repeatedly bending or stretching the cables, or placing heavy load on them.

Repetitive bending stress or tensile stress can cause breakage of the cable.

- Wire correctly.

Incorrect wiring can break the product.

- Do not perform wiring while the power is on.

Otherwise damage to the wireless unit and/or input or output device can result, causing malfunction.

- Do not route wires and cables together with power or high voltage cables.

Otherwise the wireless unit and/or input or output device can malfunction due to interference of noise and surge voltage from power and high voltage cables to the signal line.

Route the wires (piping) of the wireless unit and/or input or output device separately from power or high voltage cables.

- Confirm proper insulation of wiring.

Poor insulation (interference from another circuit, poor insulation between terminals, etc.) can lead to excess voltage or current being applied to the product, causing damage.

- Take appropriate measures against noise, such as using a noise filter, when the Fieldbus system is incorporated into equipment.

Otherwise noise can cause malfunction.

*Environment

- Select the proper type of protection according to the environment of operation.

IP67 protection class is achieved when the following conditions are met.

(1) The units are connected properly with fieldbus cable with M12 connector and power cable with M12 (M8) connector.

(2) Suitable mounting of each unit and manifold valve.

(3) Be sure to fit a waterproof cap on any unused connectors.

If using in an environment that is exposed to water splashes, please take measures such as using a cover.

Do not use in an environment where moisture or water vapor are present. Otherwise failure and malfunction can result.

- Do not use in a place where the product could be splashed by oil or chemicals.

If the product is to be used in an environment containing oils or chemicals such as coolant or cleaning solvent, even for a short time, it may be adversely affected (damage, malfunction etc.).

- Do not use the product in an environment where corrosive gases or fluids could be splashed.

Otherwise damage to the product and malfunction can result.

- Do not use in an area where surges are generated.

If there is equipment generating large surge near the unit (magnetic type lifter, high frequency inductive furnace, welding machine, motor, etc.), this can cause deterioration of the internal circuitry element of the unit or result in damage. Take measures against the surge sources, and prevent the lines from coming into close contact.

- When a surge-generating load such as a relay, valve or lamp is driven directly, use a product with a built-in surge absorbing element.
Direct drive of a load generating surge voltage can damage the unit.
- The product is CE marked, but not immune to lightning strikes. Take measures against lightning strikes in the system.
- Prevent foreign matter such as dust or wire debris from getting inside the product.
- Mount the product in a place that is not exposed to vibration or impact.
Otherwise failure or malfunction can result.
- Do not use the product in an environment that is exposed to temperature cycle.
Heat cycles other than ordinary changes in temperature can adversely affect the inside of the product.
- Do not expose the product to direct sunlight.
If using in a location directly exposed to sunlight, shade the product from the sunlight.
Otherwise failure or malfunction can result.
- Keep within the specified ambient temperature range.
Otherwise malfunction can result.
- Do not operate close to a heat source, or in a location exposed to radiant heat.
Otherwise malfunction can result.

*Adjustment and Operation

- Please refer to the I/O configuration manual for details of parameter settings.
- Perform settings suitable for the operating conditions.
Incorrect setting can cause operation failure.
(Refer to page 27 for the Setting and Adjustment.)
- Please refer to the PLC manufacturer's manual etc. for details of programming and addresses.
For the PLC protocol and programming refer to the relevant manufacturer's documentation.

*Maintenance

- Turn off the power supply, stop the supplied air, exhaust the residual pressure and verify the release of air before performing maintenance.
There is a risk of unexpected malfunction.
- Perform regular maintenance and inspections.
There is a risk of unexpected malfunction.
- After maintenance is complete, perform appropriate functional inspections.
Stop operation if the equipment does not function properly.
Otherwise safety is not assured due to an unexpected malfunction or incorrect operation.
- Do not use solvents such as benzene, thinner etc. to clean each unit.
They could damage the surface of the body and erase the markings on the body.
Use a soft cloth to remove stains.
For heavy stains, use a cloth soaked with diluted neutral detergent and fully squeezed, then wipe up the stains again with a dry cloth.

SMC Wireless System Features

The SMC wireless system has the following features:

- High-speed start up. The minimum connection time to the system after supplying power to the wireless slave unit is 0.25 seconds. *1
- Parameter setting by Near Field Communication (NFC) using a PC (no HW setting).
- Up to 31 wireless slave units can be registered to one wireless master unit. *2
- The maximum number of I/O points of the wireless system is 1280 for input and output. *3,4
- The maximum number of I/O points of the wireless master module is 128 for input and output.
- The maximum number of I/O points of the wireless slave module is 128 for input and output.

*1: The wireless master unit should be in the start upstate. The connection time varies depending on the timing of the power supply to the wireless slave unit, the number of connected EX600 I/O units and other external influences.

*2: The maximum number of units that can be connected is 31. If 31 units is exceeded, the unit I/O will not be recognized. There might be a communication delay depending on the communication load status.

*3: The maximum number of I/O point is 1280 for input and output. When exceeding 1280 points, the unit I/O is not recognized. There might be a communication delay depending on the communication load status.

*4: The total number of I/O points of the wireless master unit and the registered I/O points of the wireless slave units.

<Important >

- This product is a wireless unit in accordance with the Radio Act. Be sure to comply with the following precautions.
 - Do not disassemble or modify the product. Disassembly and modification are prohibited by law.
 - This product is compliant with the Radio Act in Japan, European countries and the US. For use in other countries, please consult SMC. Refer to the product catalog or SMC website (URL <http://www.smcworld.com>) for the latest information.
- This product communicates by radio waves, and the communication may stop instantaneously due to ambient environments and operating methods. SMC will not be responsible for any secondary failure which may cause an accident or damage to other devices or equipment.
- When several units are installed closely to each other, slight interference may occur due to the characteristics of the wireless product.
- Do not use this product close to any equipment which may cause malfunction due to radio waves from this product.
- The communication performance is affected by the ambient environment, so please perform the communication testing before use.

SMC Wireless System Outline

■ Outline

This operation manual describes the **distributed I/O system** which can provide a wireless connection to the EX600 series with complete interchangeability.

It consists of a combination of the **wireless master unit** which has upper level communication (PROFINET) and wireless connection function and the **wireless slave unit** which offers wireless connection.

The wireless master unit and wireless slave unit can be constructed into **modules** by combining them with EX600 series I/O units.

Each wireless master and slave module is able to provide **up to 128 inputs and 128 outputs**, and up to 9 I/O units can be connected to each module.

Although the wireless master is able to provide up to 128 inputs and 128 outputs as a master module, it is possible to have up to 1280 inputs and 1280 outputs by matching the number of I/O points of the registered wireless slave module.

Therefore, the maximum number of I/O points per 1 node can be 1280 points (160 bytes) / 1280 points (160 bytes) visible from the upper level communication such as a PLC.

It is possible to prevent malfunction when multiple wireless master unit and wireless slave unit are being operated in the same area by registering each PID (Product ID) of the wireless master unit and the wireless slave unit.

The packet of the wireless transmit and receive data is encrypted. It is therefore difficult to manipulate the data.

■ System configuration

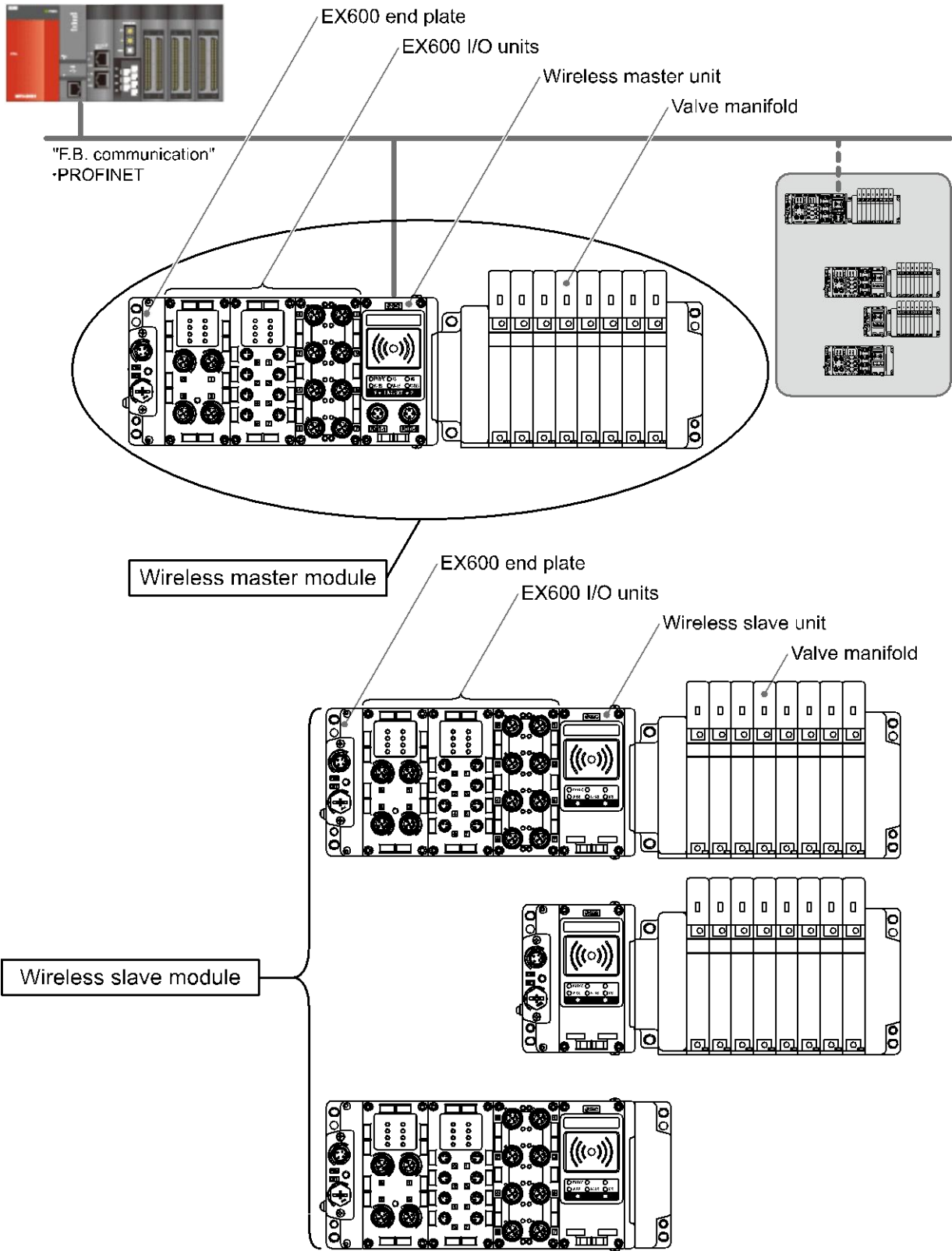

Wireless system configuration example

■Wireless master module

The construction of the wireless master module is shown below.

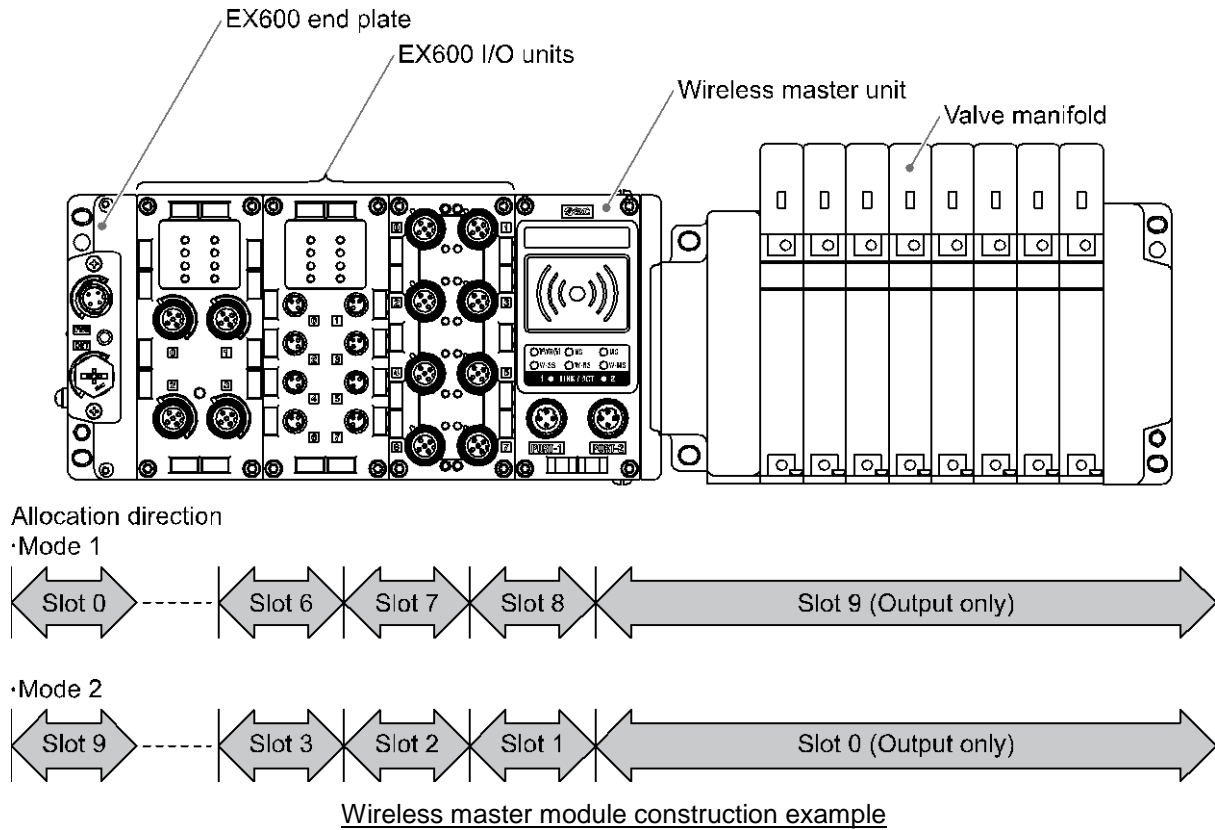

The **wireless master unit** is positioned at the center of the **wireless master module**, so that the EX600 I/O units can be connected to the left side of the wireless master unit and the valve manifold can be connected to the right side of the wireless master unit.

Refer to the SMC catalogue for the EX600 series serial transmission system for the wiring method.
http://ca01.smcworld.com/catalog/BEST-5-1-en/mpv/e02-24-ex600/pageview.html#page_num=C1

The wireless master unit transmits and receives the I/O unit information from the wireless master and wireless slave modules when connected to the upper level communication PROFINET system.

With the wireless system the allocation direction of the address (Slot No.) setting allocated to the EX600 I/O unit and the connected valve manifold can be varied for each wireless unit.
 (Refer to page 35 the section "Setting and Adjustment" for details.)

■Wireless slave module

The construction of the wireless slave module is shown below.

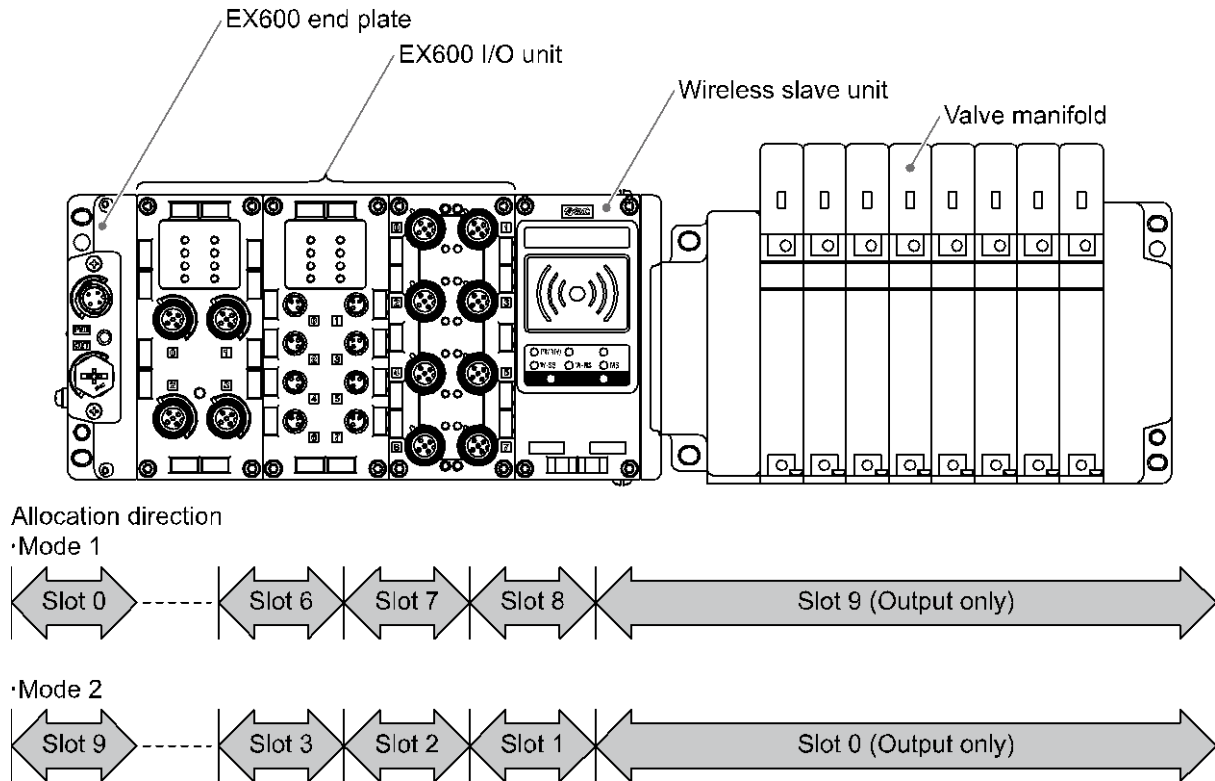

Wireless slave module construction example

The wireless slave unit is positioned at the center of the wireless slave module, so that the EX600 I/O units can be connected to the left side of the wireless slave unit and the valve manifold can be connected to the right side of the wireless slave unit, similar to the wireless master module.

Refer to the SMC catalogue for the EX600 series serial transmission system for the wiring method.
http://ca01.smcworld.com/catalog/BEST-5-1-en/mpv/e02-24-ex600/pageview.html#page_num=C1

The wireless slave unit has a construction that is separated from the PROFINET communication function by the wireless master unit, and therefore it transmits / receives the information of the connected I/O units and valve manifold to/ from the wireless master unit.

With the wireless system the allocation direction of the address (Slot No.) setting allocated to the EX600 I/O unit and the connected valve manifold can be varied for each wireless unit.
 (Refer to page 40 the section "Setting and Adjustment" for details.)

■ Definition and terminology

	Term	Definition
100	100BASE-TX	Standard LAN transmission line with communication speed of 100 Mbps.
B	Broken line detection	A broken wire to the input or output equipment has been detected by the diagnostic function.
C	Current consumption	Current which is necessary to operate each unit.
D	DHCP	A protocol that automatically allocates information, necessary to be registered to use the network, such as an IP address, to individual devices connected to the TCP/IP network.
	DIN rail	A metal rail conforming with the DIN (German) standard.
	D Side	The side connected to the end plate when the product is connected to a manifold.
E	Enclosure (IP)	Abbreviation of International Protection. Standard related to protection against extraneous matter, such as hand, steel ball, steel wire, dust particle or water, applied to the product.
F	FE	Abbreviation of functional earth. The word "earth" refers to this functional earth.
	Fieldbus	Network protocol to establish digital communication between an automated industrial system such as a measurement tool or manipulation tool and a PLC.
	FSU	
	Full duplex	Communication system that can send and receive data at the same time bi-directionally.
G	GSDML file	File describes the product master data.
H	Half-duplex	Communication method that can send and receive data reciprocally in bi-directional communication.
I	Idle	Wireless master unit has received the FAIL SAFE command, and remains idle. The output state can be set to CLEAR, HOLD or Software Control using the parameter settings.
	IP address	A 32 bit digit sequence which is assigned to identify devices which are connected to the network.
M	MAC address	A unique number inherent to all devices connected to an PROFINET network.
	Manifold	Aggregate.
	MRP	
N	NFC	Abbreviation of Near Field Communication. Non-contact short distance wireless communication. It is accessible using a card reader/ writer by using a special application.
	NPN output	The output type that uses an NPN transistor to operate an output device. This is also known as a positive common type since a positive potential is applied to the power supply line.
	NPN input	Accepts a sensor output that uses the NPN transistor output signal .
	Number of inputs	Number of points which can receive information from input equipment such as a sensor or switch.
	Number of outputs	Number of points which can operate output equipment such as a valve, lamp or motor starter.

	Term	Definition
P	Paring	Registration of the PID (Product ID) of the wireless slave unit to be connected to the wireless master unit. Registration occurs at the initial setting, then wireless system will activate.
	PID	Abbreviation of Product ID. A 32 bit digit sequence which is assigned to identify the wireless unit (master / slave unit).
	PLC	Abbreviation of Programmable Logic Controller. A digital computer used for automation of electromechanical processes.
	PNP output	The output type that uses a PNP transistor to operate an output device. This is also known as a negative common type since a negative potential is applied to the power supply line.
	PNP input	Accepts a sensor output that uses the PNP transistor output signal .
Q	QuickConnect™	Function to shorten the time from initial operation of the equipment after supplying power to starting communication.
S	Short circuit detection	Diagnostic function which detects generation of over current due to a short circuit between the output and the positive power supply line or the ground line.
	Short circuit protection	Function which avoids damage to the internal circuit when over current is generated due to short circuit between the output and the positive power supply line or the ground line.
	SI unit	Abbreviation of Serial Interface Unit. A unit connected to a PLC to communicate input and output data.
U	U side	The side connected to the valve manifold when the EX600 is connected to a manifold.
W	WiFi	Abbreviation of Wireless Fidelity. Brand name which indicates the wireless LAN equipment is compliant to an international standard.
	Wireless channel	Identification number of the wireless slave unit connected to the wireless master unit.
	Wireless master	A unit which establishes wireless communication of input or output data to the wireless slave. It is connected to a PLC to establish communication of input or output data.
	Wireless slave	A unit which establishes wireless communication of input or output data to the wireless master.
	Wireless unit	A unit which establishes wireless communication. This is a generic name of the wireless master and slave units.
	Wireless system	This is a general term for the network including wireless master and slaves.

Assembly

•Assembling the unit as a manifold

- (1) Connect a unit to the end plate.
Digital and analogue units can be connected in any order.
(Tightening torque: 1.5 to 1.6 Nm)

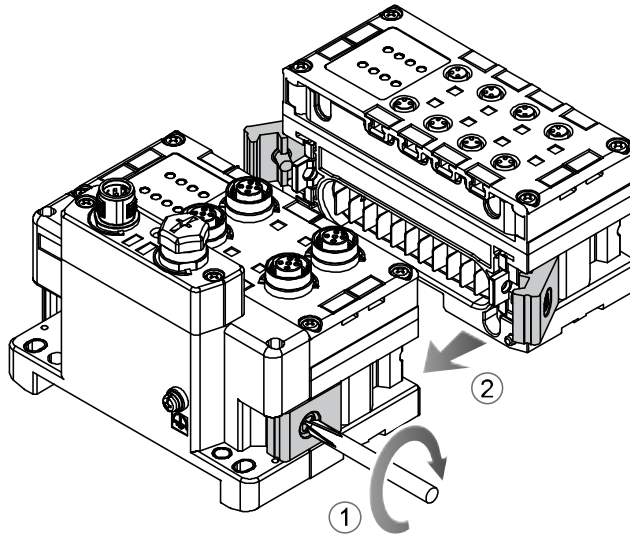

- (2) Add more units.
Up to 9 units can be connected to one manifold.

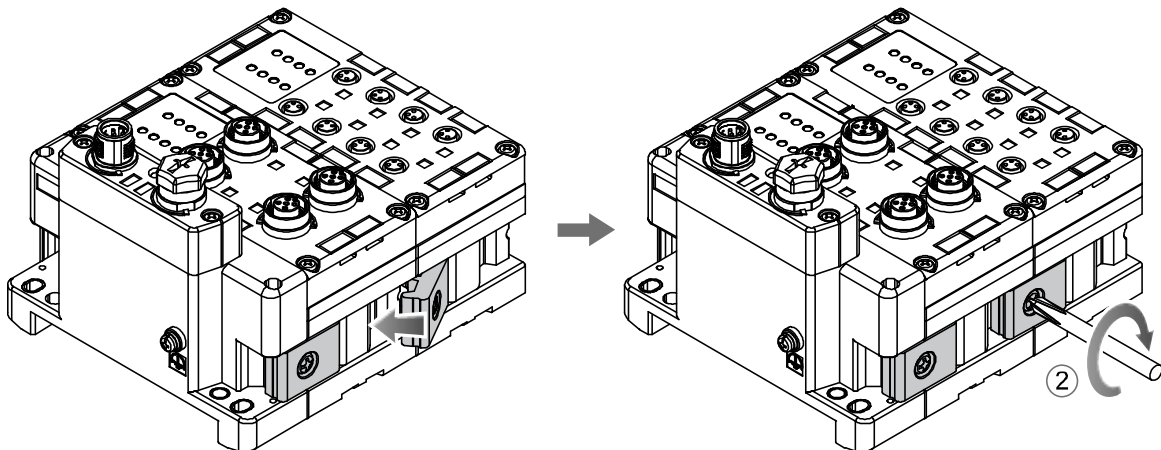

- (3) Connecting the wireless unit
After connecting the required I/O units, connect the wireless unit.
The connection method is as above.

(4) Mounting the valve plate. (Valve manifold not connected → Refer to page 17)

Mount the valve plate (EX600-ZMV*) to the valve manifold using the set screws (M3 x 8) provided with the product. (Tightening torque: 0.6 to 0.7 Nm)

Screw mounting
places

SV: 2 places

S0700: 2 places

VQC1000: 2 places

VQC2000: 3 places

VQC4000: 4 places

SY: 2 places

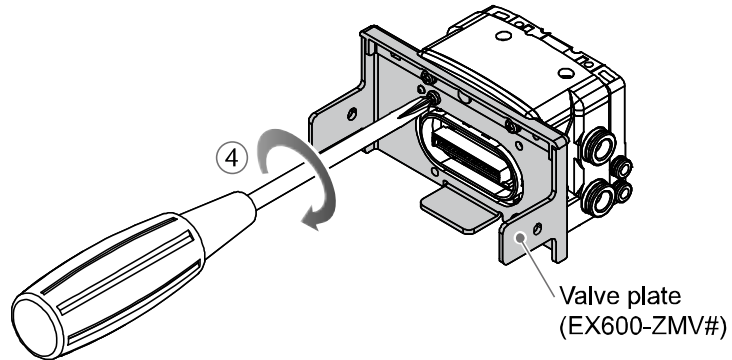

(5) Connect the wireless unit to the valve manifold.

Insert the valve plate into the valve plate mounting groove on the side of the wireless unit, and then fix both surfaces of the plate using the valve plate mounting screws (M4 x 6) provided with the product. (Tightening torque: 0.7 to 0.8 Nm)

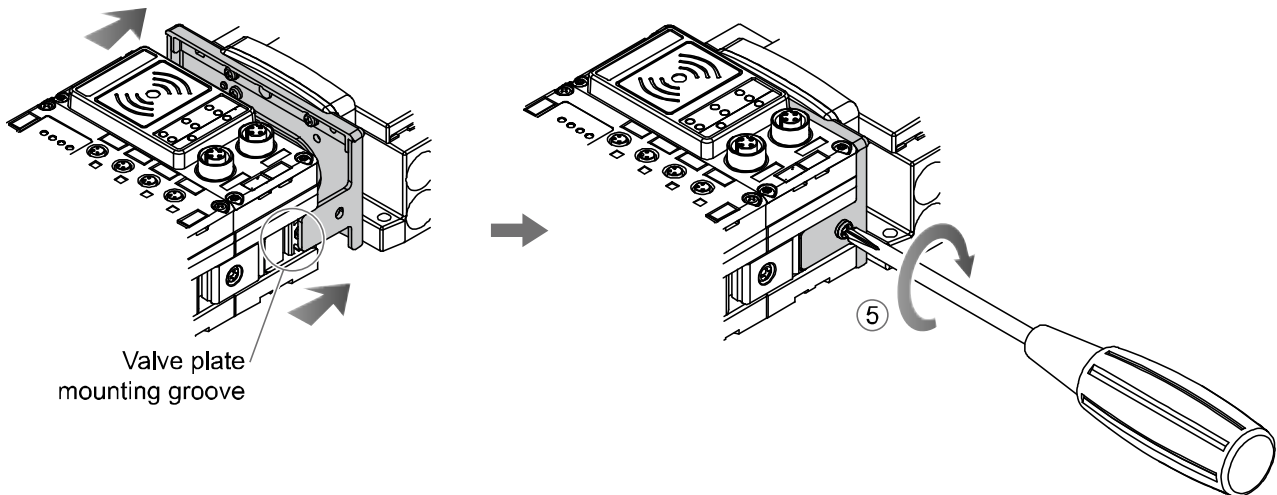

(6) When valve manifold is not connected.

Insert the end plate (EX600-EU1) into the valve plate mounting groove on the side of the wireless unit, and then fix both surfaces of the plate using the valve plate mounting screws (M4 x 6) provided with the product. (Tightening torque: 0.7 to 0.8 Nm)

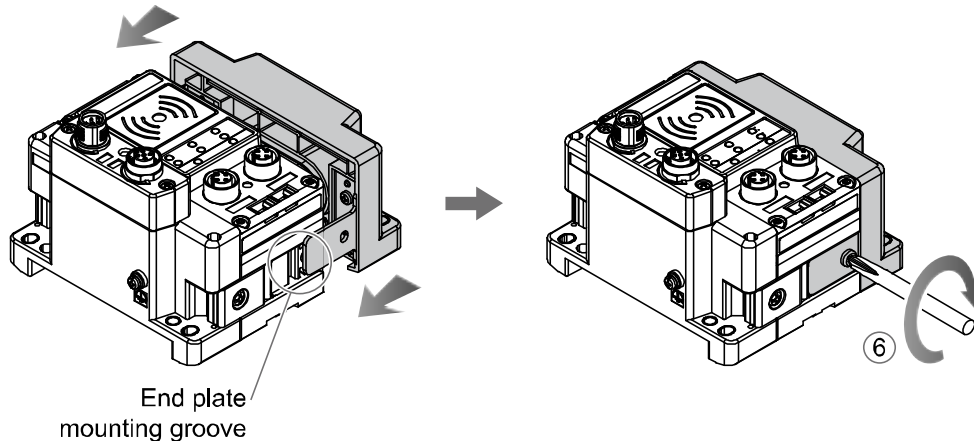

Mounting and Installation

■ Installation

• Direct mounting

- (1) When joining six or more units, fix the middle part of the complete EX600 unit with an intermediate reinforcing brace (EX600-ZMB1) before mounting, using 2-M4x5 screws. (Tightening torque: 0.7 to 0.8 Nm)

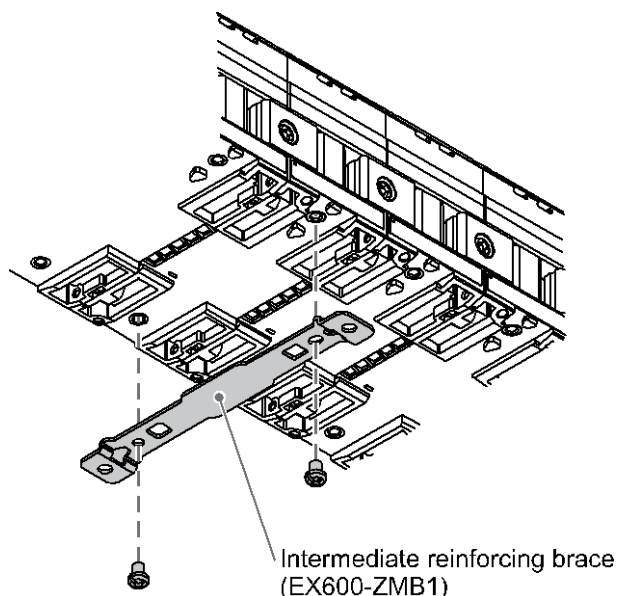

- (2) Mount and tighten the end plate and the valve manifold (intermediate reinforcing brace if necessary) at one end of the unit. (M4)
 (Tightening torque: 0.7 to 0.8 Nm)
 Refer to the Operation Manual of the applicable valve manifold for the mounting method of the valve side.

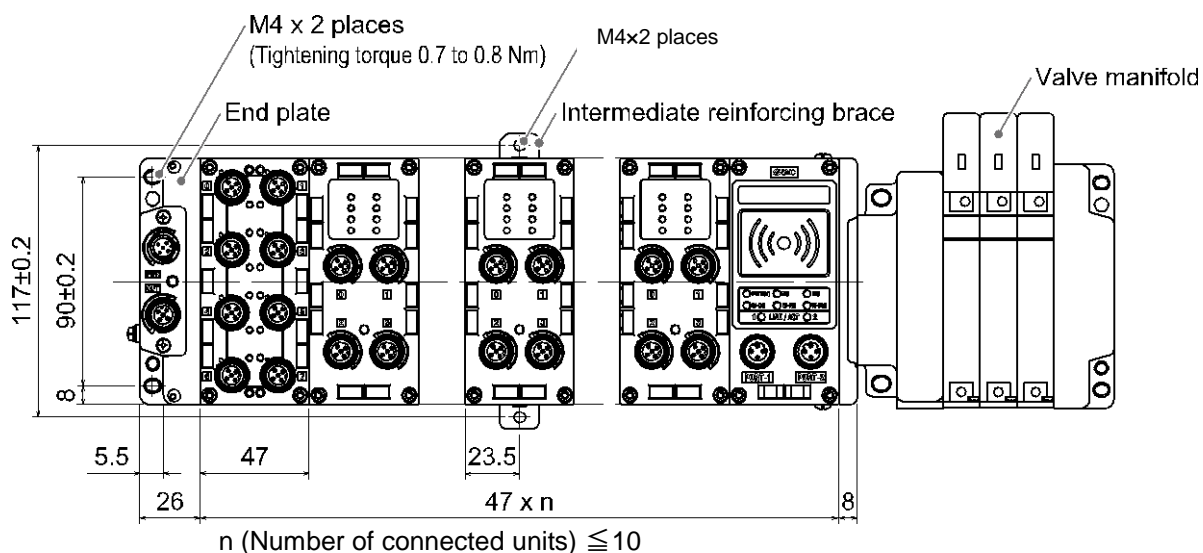

● Handling Precautions

- When joining six or more units, fix the middle part of the complete unit with an intermediate reinforcing brace to prevent incorrect connection between the units due to deflection.

•DIN rail mounting

- (1) When joining six or more units, fix the middle part of the complete EX600 unit with an intermediate reinforcing brace (EX600-ZMB2) for DIN rail before mounting, using 2-M4 x 6 screws. (Tightening torque: 0.7 to 0.8 Nm)
- (2) Mount the end plate bracket (EX600-ZMA2) to the end plate using 2-M4 x 14 screws. (Tightening torque: 0.7 to 0.8 Nm) For the SY series, use the end plate bracket (EX600-ZMA3).

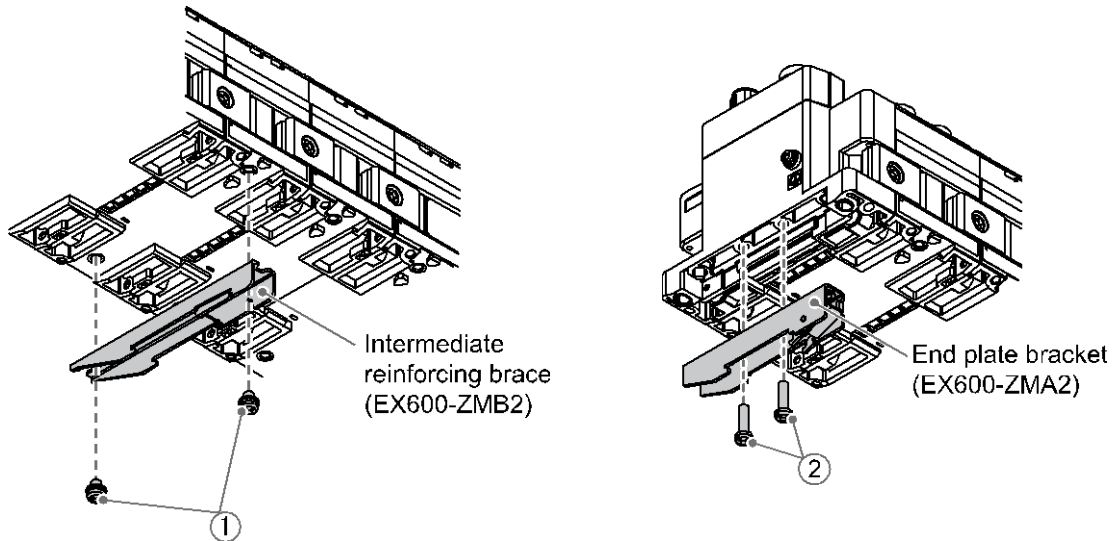

- (3) Hook the DIN rail mounting groove on to the DIN rail.
 - (4) Press the manifold using its side hooked to the DIN rail as a fulcrum until the manifold is locked.
 - (5) Fix the end plate bracket (EX600-ZMA2) to the manifold using the M4 x 20 screws provided with the product. (Tightening torque: 0.7 to 0.8 Nm)
- Refer to the Operation Manual of the applicable valve manifold for the mounting method of the valve side.

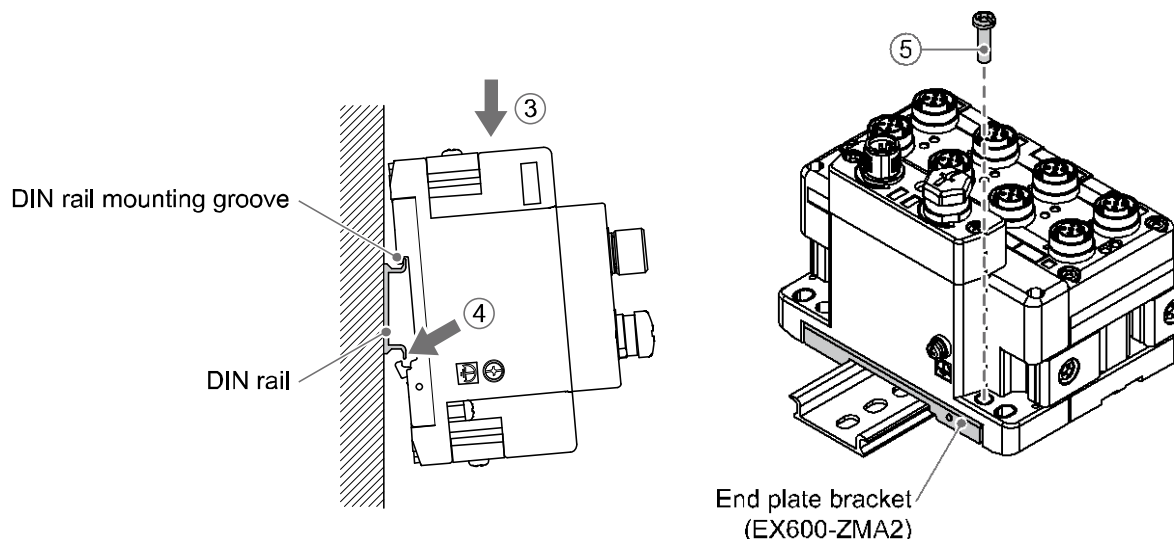

•Mounting the marker

The signal name of the input or output devices and unit address can be written on the marker, and can be installed on each unit.

Mount the marker (EX600-ZT1) into the marker groove as required.

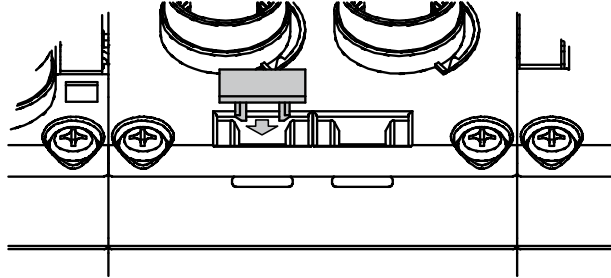

Model Indication and How to Order

•Wireless master unit

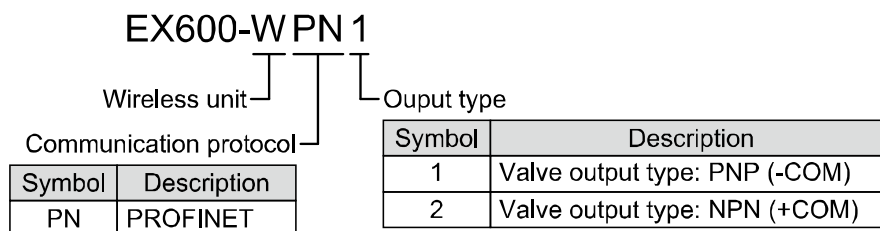

•Wireless slave unit

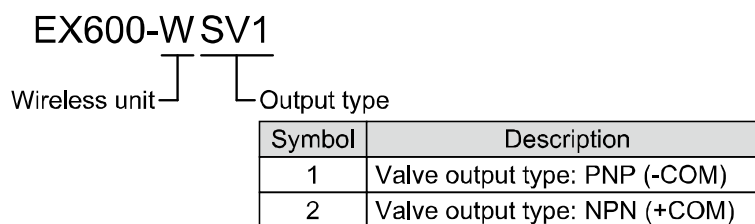

Summary of Product Parts

•Wireless master unit

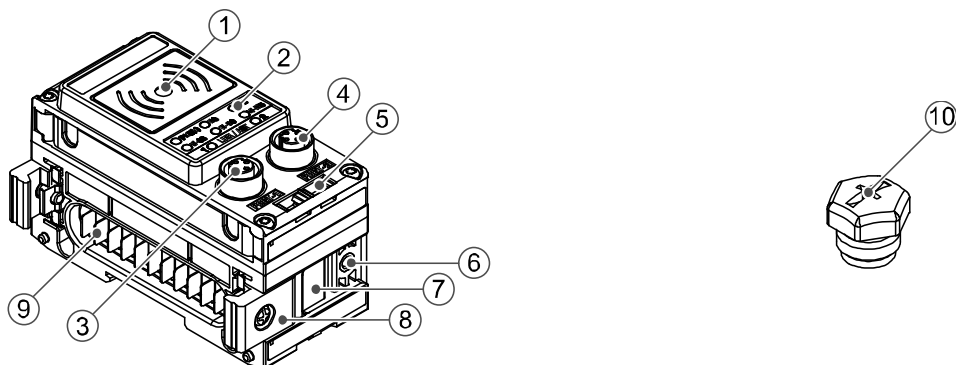

No.	Item	Application
1	Area close to NFC antenna	This area is in close contact with the NFC reader/writer. "O" is the center of the NFC antenna.
2	Status indication LED	LED display to indicate the unit status.
3	Connector (PORT-1)	Fieldbus input/output cable connection.
4	Connector (PORT-2)	Fieldbus input/output cable connection.
5	Marker groove	Marker(EX600-ZT1) can be mounted.
6	Screw hole for valve plate mounting	For fixing the valve plate.
7	Valve plate mounting groove	Groove to insert the valve plate.
8	Joint bracket	Bracket for mounting adjacent units.
9	Unit connector (plug)	Transfers signals to the next unit and supplies power.
10	Seal cap (1 pc.)	To be mounted on unused connectors (PORT 1 or PORT 2).

•Wireless slave unit

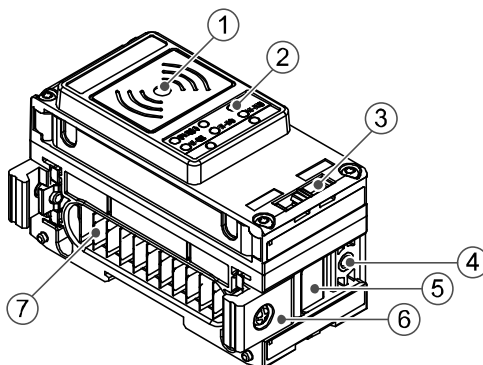

No.	Item	Application
1	Area close to NFC antenna	This area is in close contact with the NFC reader/writer. "O" is the center of the NFC antenna.
2	Status indication LED	LED display to indicate the unit status.
3	Marker groove	Marker(EX600-ZT1) can be mounted.
4	Screw hole for valve plate mounting	For fixing the valve plate.
5	Valve plate mounting groove	Groove to insert the valve plate.
6	Joint bracket	Bracket for mounting adjacent units.
7	Unit connector (plug)	Transfers signals to the next unit and supplies power.

■ Connector (Wireless master unit only)

This system is operated using power supplied from the EX600-ED* end plate.
Refer to the end plate details for the power supply connection.

The wireless master unit is connected to the upper level communication (PROFINET). The connector has 2 ports, PORT-1 and PORT-2, and both ports can connect to PROFINET. The PROFINET topology corresponds to star, line, tree and ring.

•Connector pin No.

M12 4-pin Socket D code

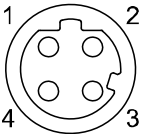
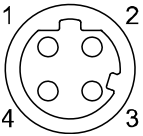
Connector		Pin No.	Signal name
PORT-1	PORT-2		
		1	TD+
		2	RD+
		3	TD-
		4	RD-

PROFINET connector of wireless master unit

LED Display

■ LED indication of wireless master unit

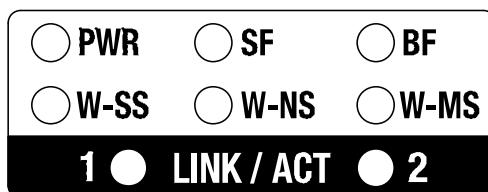

LED indication of wireless master

• LED specifications of wireless master unit

LED name	Function	Colour of LED	Operation
PWR	Power supply voltage (US1・US2)	Green LED is ON.	Power supply voltage for control and input (US1) is normal Power supply voltage for output (US2) is normal
		Red LED flashes.	Power supply voltage for control and input (US1) is normal Power supply voltage for output (US2) is abnormal (Power Supply voltage monitor(Output)is valid)
		Red LED flashes	Power supply voltage for control and input (US1) is abnormal (Power Supply voltage monitor(Control/Input)is valid)
		OFF	Power supply voltage for control and input (US1) is not supplied
SF	Wireless master module system status	OFF	Normal operation
		Green LED flashes	Node flashing test command received
		Red LED flashes	Restorable error is detected (LED flashes when more than one diagnostic information item is detected) · Abnormal power supply voltage level for control and input(US1) (Power Supply voltage monitor(Control/Input)is valid) · Abnormal power supply voltage level for output (US2) (Power Supply voltage monitor(Output)is valid) · Excessive I/O setting inputs/outputs · Analogue I/O upper and lower set limit exceeded · Analogue Input range upper and lower limit exceeded · Abnormal number of slave connections · Error in communication between units · EX600 I/O unit detects diagnostic information · Valve diagnostic information detected
		Red LED is ON	Non-restorable error is detected (e.g. Hardware failure)
BF	PROFINET connection status	OFF	PROFINET communication is established
		Red LED flashes	PROFINET controller settings and EX600 configuration data do not match
		Red LED is ON	PROFINET communication is not established · PROFINET controller power supply is OFF · Cable connection error between PROFINET controller and wireless master unit · PROFINET controller or the wireless master unit are faulty · PROFINET controller settings and wireless master unit Device name do not match

LED name	Function	Colour of LED	Operation
W-SS	Radio wave receiving intensity (For communication from wireless slave to wireless master)	Green LED is ON	Received power level of all slaves is 3
		Green LED flashes. (1 Hz)	There are connected slaves with received power level 2.
		Green LED flashes. (2 Hz)	There are connected slaves with received power level 1.
		Red LED flashes.	No wireless slaves connected.
		OFF	Wireless slave unit is not registered.
W-NS	Wireless communication connection status	Green LED is ON.	All wireless slave units are connected correctly.
		Green LED flashes.	There are unconnected wireless slave units.
		Red LED flashes.	All wireless slave units are unconnected.
		Red LED is ON.	All wireless slave units are unconnected. (non-restorable error in wireless communication)
		Red/green	Wireless communication connection is under construction (Pairing)
		Orange LED is ON.	Forced output mode
		OFF	Wireless slave unit is not registered.
W-MS	Wireless slave module connection system status	Green LED is ON.	Wireless slave module is normal.
		Red LED flashes.	Restorable error is detected (LED flashes when more than one diagnostic information item is detected) <ul style="list-style-type: none"> •Abnormal power supply voltage level for control and input (US1) •Abnormal power supply voltage level for output (US2) •Excessive I/O setting inputs/outputs •Analogue I/O upper and lower set limit exceeded •Analogue Input range upper and lower limit exceeded •Error in communication between units •EX600 I/O unit detects diagnostic information •Valve diagnostic information detected
		Red LED is ON.	Non-restorable error is detected (e.g. Hardware failure)
		OFF	No wireless slave unit connected.
LINK/ACT1	Communication status of PROFINET ports 1 and 2	Green LED is ON.	Link, No Activity
LINK/ACT2.		Green LED flashes.	Link, Activity
		OFF	No Link, No Activity

*:If there are multiple conditions for LED ON/Flashing, the detailed information can be seen only when the setting of the diagnostic information is "Simple" or "Detailed".

■ LED indication of wireless slave unit

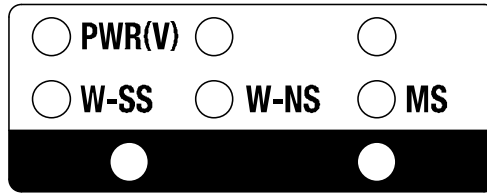

LED indication of wireless slave

• LED Indication of wireless slave unit

LED name	Function	Colour of LED	Operation
PWR (V)	Power supply voltage for output (US2)	Green LED is ON.	Power supply voltage for output (US2) is normal.
		Red LED flashes.	Power supply voltage for output (US2) is abnormal (Indication only. The product can be operated.) (Power Supply voltage monitor(Output)is valid)
		OFF	Power supply for control and input (US1) is not supplied.
MS	Wireless slave module system status	Green LED is ON.	Wireless slave module is normal.
		Red LED flashes.	Restorable error is detected. (LED flashes when more than one diagnostic information item is detected.) •Abnormal power supply voltage level for control and input (Power Supply voltage monitor(Control/Input)is valid) •Excessive I/O setting inputs/outputs •Analogue I/O upper and lower set limit exceeded •Analogue Input range upper and lower limit exceeded •Error in communication between units •EX600 I/O unit detects diagnostic information •Valve diagnostic information detected
		Red LED is ON.	Non-restorable error is detected (e.g. Hardware failure)
		OFF	Power supply for control and input (US1) is not supplied.
W-SS	Radio wave receiving intensity (Communication from wireless master to wireless slave)	Green LED is ON.	Received power level is 3.
		Green LED flashes. (1 Hz)	Received power level is 2.
		Green LED flashes. (2 Hz)	Received power level is 1.
		Red LED flashes.	Wireless communication is not connected.
		OFF	Wireless master unit is not registered.
W-NS	Wireless communication connection status	Green LED is ON	Wireless slave is connected correctly.
		Red LED flashes.	No wireless slaves connected.
		Red LED is ON.	No wireless slaves connected (non-restorable error in wireless communication)
		Red/green	Wireless communication connection is under construction (Pairing)
		Orange LED is ON.	Forced output mode
		OFF	Wireless master unit is not registered.

*: If there are multiple conditions for LED ON/Flashing, the detailed information can be seen only when the setting of the diagnostic information is "Simple" or "Detailed".

Setting and Adjustment

■ Flow chart for using the wireless system

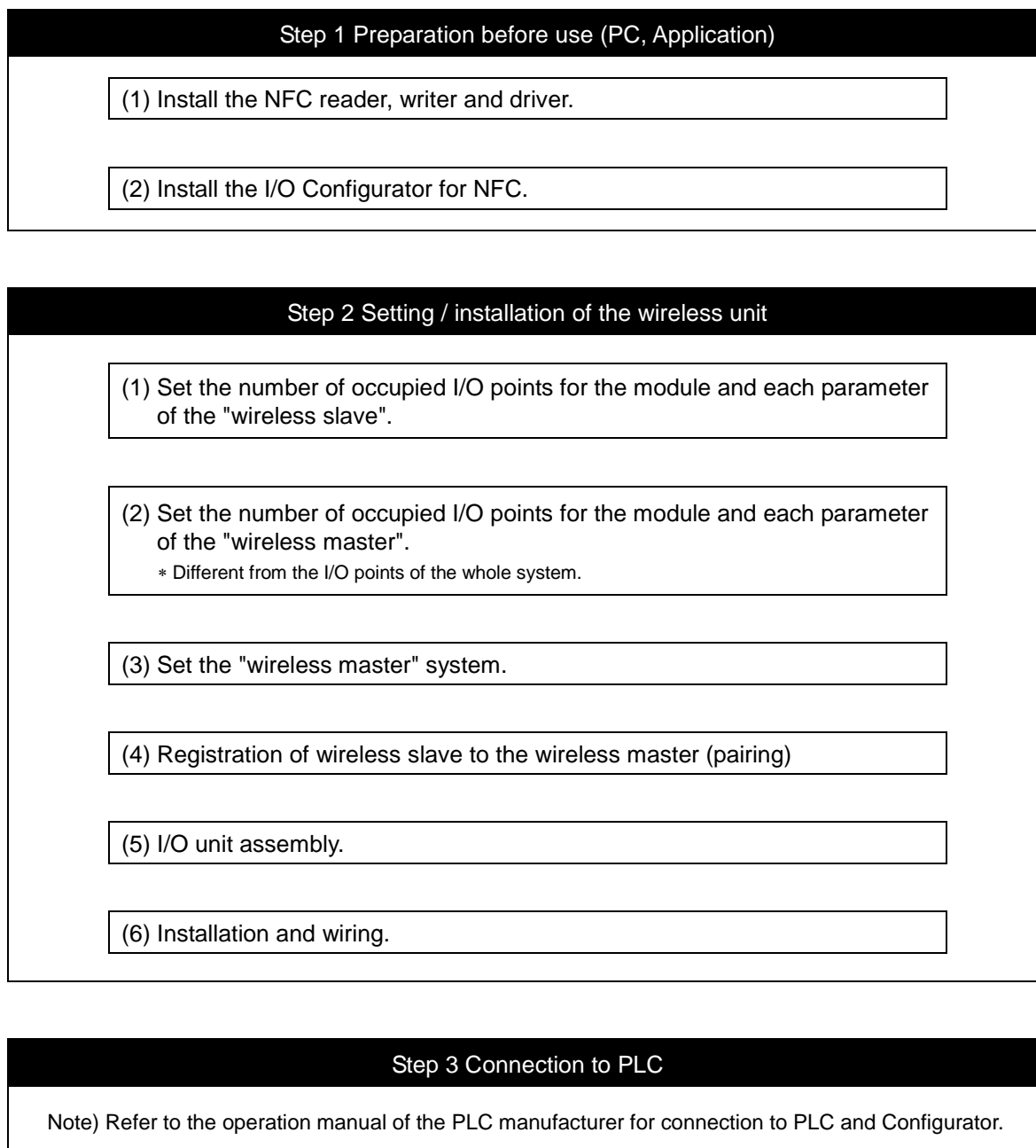

With the above settings, it is possible to control the upper level controller.

Refer to the operation manual for each manufacturer for how to set the controller and the PLC.

Refer to the I/O Configurator for NFC operation manual and I/O Configurator (Web) operation manual for details of the I/O Configurator.

■ Setting

• SMC wireless system I/O Configurator for NFC

The SMC wireless system I/O Configurator for NFC can be used to check the parameter setting of the wireless unit and the contents and status of the constructed wireless system, using an NFC reader/writer and a PC.

There are two types of settable parameters with the I/O Configurator: the parameters which can be read or written **when no power is supplied to the product** and the parameters which can be read or written **only when the power is supplied to the product**.

The connection details of the I/O Configurator for NFC and the wireless unit is shown in the below figure.

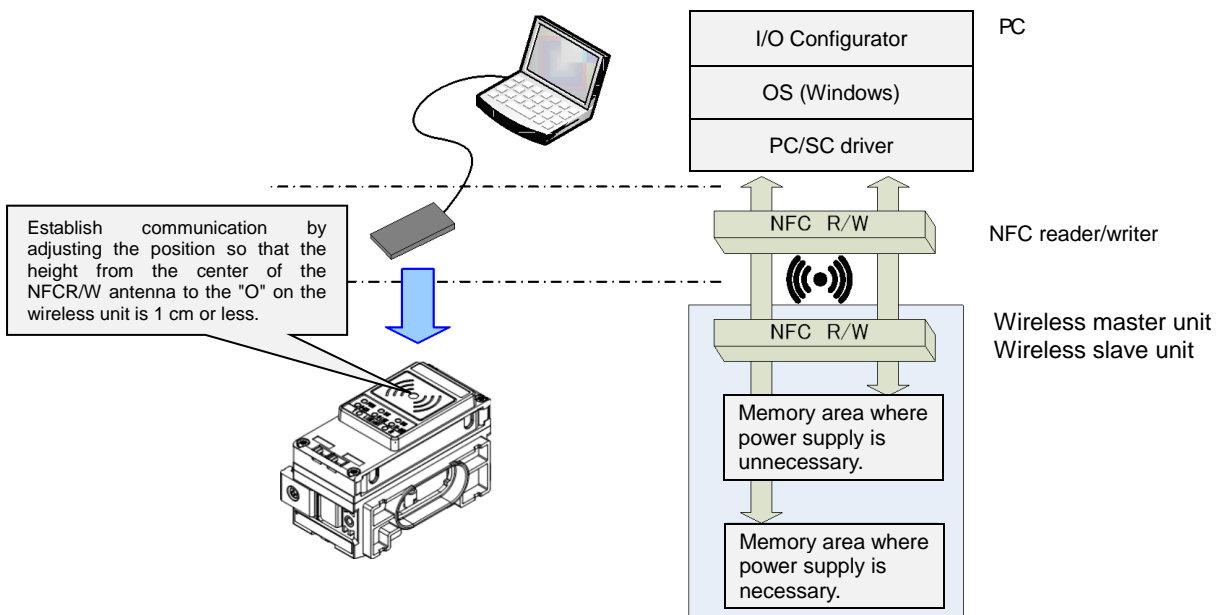

Connection details of the I/O Configurator for NFC and the wireless unit

To use the I/O Configurator for NFC, it is necessary to install a driver and set the NFC reader/writer on the PC beforehand.

Refer to the Operation Manual for the I/O Configurator for further details.

*: About the communication timing

The NFC communication is not accessed all the time. Therefore, it is necessary to update the contents displayed on the screen by clicking the "Refresh button" when reading the parameters. The parameters changed are valid after re-supplying the power supply or by pressing the reset button in the I/O Configurator screen. As the parameter setting requires time for settlement, do not turn off the power supply for 2 seconds.

*: Establishing communication after changing units

As the settings between the wireless master unit and the wireless slave unit are different, it is necessary to update the displayed parameter by clicking the "Refresh button" on the screen of the I/O Configurator for NFC after changing the unit in which the parameter is set.

*: Operation already checked. NFC reader / writer
SONY RC-S380/S

*: I/O Configurator (Web version)

This operation manual explains the outline of the setting using the I/O Configurator (NFC). I/O Configurator (Web) is used to set the module I/O occupied points and parameters for the "wireless master" and parameters for the "I/O devices". Refer to the operation manual for the I/O Configurator (Web version).

•Installation preparation of the I/O Configurator for NFC

Driver: The following drivers should be installed before using this software.

(1): Microsoft. Net Framework 4.0 or higher

<http://www.microsoft.com/ja-JP/download/details.aspx?id=17718>

(2): NFC reader, writer connection driver NFC port software (Old FeliCa port software) (Ver 5.5.0.6 / Approx.39 MB / Apr.24.2017)

<http://www.sony.net/Products/felica/business/products/RC-S380.html>

The NFC setting on the control panel of your PC must be changed as follows.

Setting: Operate the NFC-B preferentially using the protocol used.

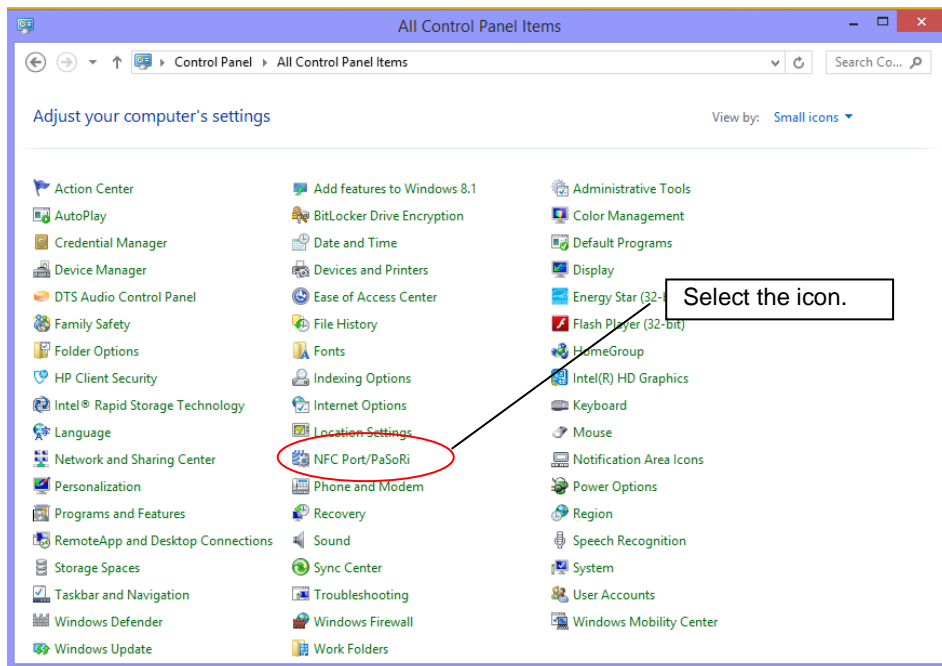

Double-click the [NFC port/PaSoRi] icon on the control panel to display the setting window.

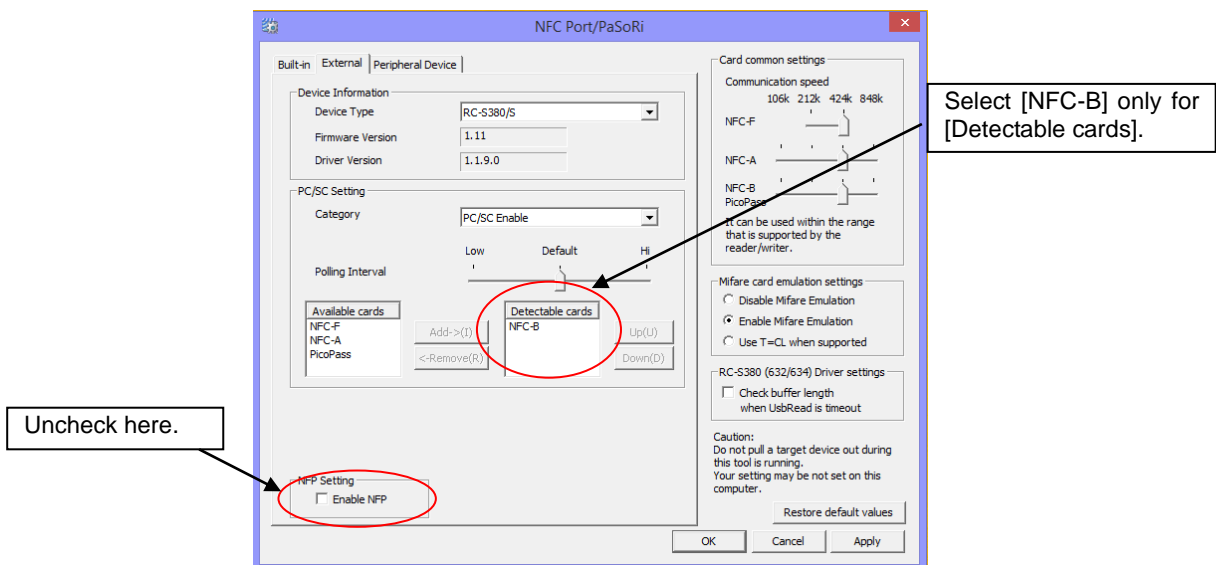

When the setting window is displayed, move [NFC-F], [NFC-A] and [PicoPass] from the card information indicated on the [Detectable cards] to the [Available cards] selection box using the "Delete" button.

If the FeliCa application [FeliCa application setting] is checked first, uncheck it. When the setting is complete, press the [OK] button on the right lower part of the window to close the window.

Copy the file shown to an arbitrary folder and click [SMCWirelessSystem.exe] to start the application.

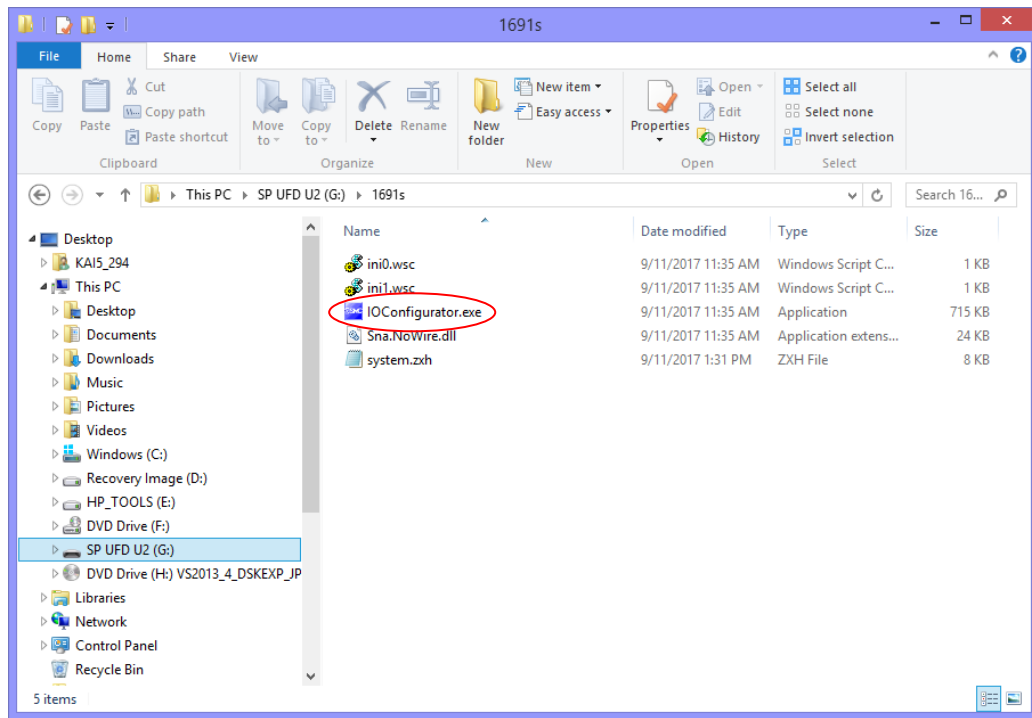

•Configuration of the I/O Configurator for NFC

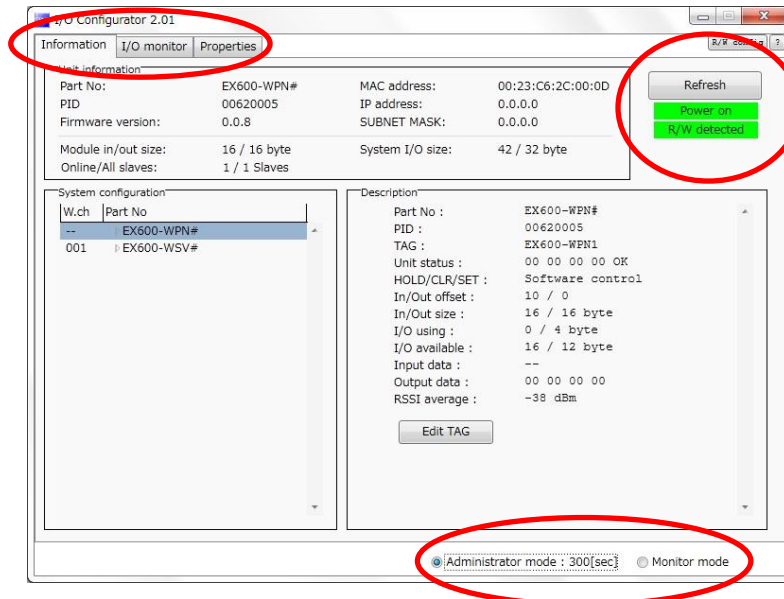

The I/O Configurator for NFC is mainly configured using the following three tabs.

Information tab

- Module information: shows information about the wireless unit.
- System configuration: shows the configuration information (connected units) of the wireless master/slave module.
The system configuration of only the wireless master unit is shown in a tree-like profile.
- Detailed information: shows detailed information about the unit selected in the system configuration.

Input/Output monitor tab

- Input: shows the input map information of the wireless unit.
- Output: shows the output map information of the wireless unit.

Setting tab

- Set item: Sets the parameter required to operate the wireless master/slave unit.

*: The contents of the setting tab is different between the wireless master unit and the wireless slave unit.
Refer to the wireless system parameter list for details.

The function of the upper right button of the "I/O Configurator (NFC)" is described below.

Refresh button

- Clicking the refresh button while holding the NFC reader / writer to the master and slaves can reflect the setting of the master / slave units on the I/O Configurator screen.

Power supply ON / OFF button

- "Power supply ON" is displayed when power is supplied to the master/ slave units, and "Power supply OFF" is displayed when power is not supplied.

R/W detection / R/W no-detection button

- When the NFC reader / writer (R/W) is inserted into the USB port of the PC and the PC detects the NFC reader and writer, "R/W detected" is displayed. When the PC cannot detect it, "R/W undetected" is displayed.

NFC setting button

- When the NFC setting button is clicked, "NFC port / PaSoRi" is displayed on the setting screen.
(Refer to page 29.)

The I/O Configurator for NFC has two modes: Administrator mode which can change the parameter setting and Monitor mode which can only read the parameter.

Administrator mode: available to read and write the parameters.

Monitor mode: available to read the parameter only. Writing parameter is not available.

Enter the correct password to enter administrator mode.

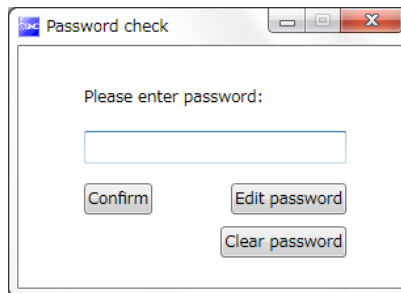

Default password: admin

If the password is forgotten, use the [Clear password] function. When the [Clear password] button is pressed, the password clear window will appear. The password will be cleared when the master factory key is entered. Then it is possible to enter administrator mode without inputting the password.

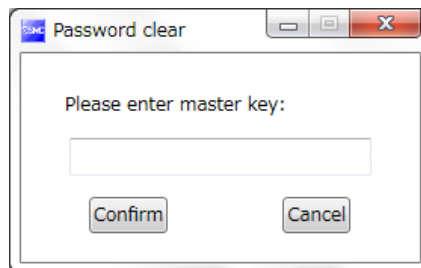

Master key: ADMIN

A password can be set using Administrator mode to prevent mischievous action by others. It is recommended to change the password at the time of first accessing.

•Wireless system parameter list

•Wireless master unit setting parameters

Classification	Parameter name	Set value	Default	Setting when not energized	Note
Master unit setting	a) Hold / Clear (unit)	Clear / Hold / Software control	CLEAR	Available	Setting of output operation status when PROFINET communication is disconnected.
	b) Input size	0 to 128 points (0 to 16 bytes) Increase and decrease by 16 points.	128 points/16 byte	Available	
	c) Output size	0 to 128 points (0 to 16 bytes) Increase and decrease by 16 points.	128 points / 16 bytes	Available	
	d) Valve manifold output size	0 to 32 points (0 to 4 bytes) Increase and decrease by 8 points.	32 points / 4 bytes	Available	The valve output size is included in the output size of each station. The number of effective points is limited within the set range of the output size.
	e) Wireless communication	Active / Idle	Active	Available	If it is set to "Idle", the wireless communication is disconnected.
	f) Unit address order	Mode 1 / Mode 2	Mode 1	Available	Mode 1: Allocation to the right from the end plate. Mode 2: Allocation to the left from the wireless unit.
System setting	a) I/O mapping	Auto mapping	Auto mapping	Available	I/O mapping of PROFINET compatible wireless master corresponds to automatic assignment only.
	b) System input size	16 to 1280 points (2 to 160 bytes) Increase and decrease by 128 points.	1280 points /160 byte	Available	This is not settable when the I/O mapping is set to "Auto".
	c) System output size	16 to 1280 points (2 to 160 bytes) Increase and decrease by 128 points.	1280 points /160 byte	Available	This is not settable when the I/O mapping is set to "Auto".
	d) Diagnostic allocation	None / Simple / Detailed	Detailed	Available	Diagnostic information is allocated to the head of the input data of the I/O map.
	e) Max slave units	0 / 15 / 31 pcs.	15 pcs.	Available	The wireless channel equivalent to the number of set units is valid.
	f) DA refresh time	0.1/0.2/0.5/1/2/5 /10/30/60s	1s	Available	Set the sampling frequency of the analogue output equipment.
Slave unit registration	a) Pairing	Pairing disable / Pairing enable	Pairing disable	Available	Pairing disable: Wireless slave cannot be registered (wireless communication to the registered wireless slave will be established). Pairing enable: Wireless slave can be registered.
	b) Slave unit registration	Allocation and registration of the wireless slave unit to the wireless channel.	No slave registered	Not available	
	c) Dummy	Addition of dummy slave to the wireless channel	dummy slave unset	Not available	Refer to dummy slave registration for details setting.

•Wireless slave unit setting parameters

Classification	Parameter name	Set value	Default	Setting when not energized	Note
Slave unit setting	a) Hold / Clear (unit)	Clear / Hold / Software control	Clear	Available	Setting of output operation status when PROFINET communication is disconnected.
	b) Input size	0 to 128 points (0 to 16 bytes) Increase and decrease by 16 points.	128 points / 16 bytes	Available	
	c) Output size	0 to 128 points (0 to 16 bytes) Increase and decrease by 16 points.	128 points / 16 bytes	Available	
	d) Valve manifold output size	0 to 32 points (0 to 4 bytes) Increase and decrease by 8 points.	32 points / 4 bytes	Available	The valve output size is included in the output size of each station. The number of effective points is limited within the set range of the output size.
	e) Wireless communication	Active / Idle	Active	Available	If it is set to "Idle", the wireless communication is disconnected.
	f) AD refresh time	0.1/0.2/0.5/1/2/5 /10/30/60s	1s	Available	Set the sampling frequency of the analogue input equipment.
	g) Unit address order	Mode 1 / Mode 2	Mode 1	Available	Mode 1: Allocation to the right from the end plate. Mode 2: Allocation to the left from the wireless unit.
Pairing setting	a) Pairing	Pairing disable / Pairing enable	Pairing disable	Available	Pairing disable: Wireless slave cannot be registered (wireless communication to the registered wireless slave will be established). Pairing enable: Wireless slave can be registered.

•Common parameter of wireless master unit and the wireless slave unit

Classification	Parameter name	Set value	Default	Setting when not energized	Note
Information	TAG	Max. 15 letters	Product No. (EX600-WPN#)	Available	Letters which can be input are half-width characters (alphabets, numbers, symbols) that correspond to ASCII code. It is not possible to write to the slave during a non-energized state.
			Product No. (EX600-WSV#)		

•Detailed wireless master parameters

The following three settings need to be performed to set the parameters of the wireless master.

- (1) Master unit setting
- (2) System setting
- (3) Slave unit registration

(1) Master unit setting

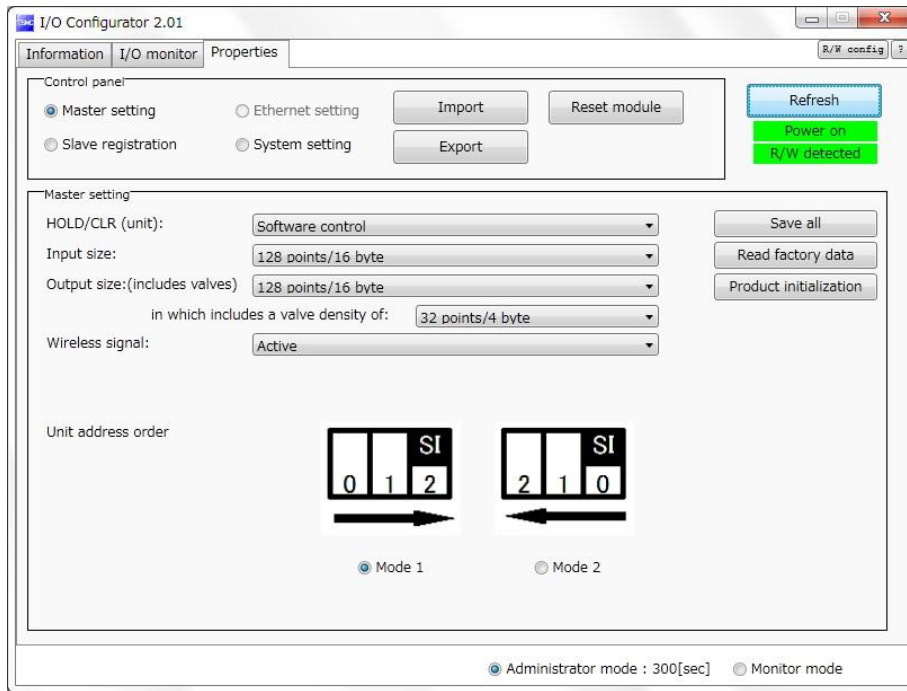

a) Hold / Clear (unit)

Define all settings in the output operation status when the PROFINET communication is disconnected.

CLEAR: Clear the output.

HOLD: Fix the output at the current value.

Software control: Clear, Hold or Set can be set by software bit.

(The detailed setting of the Software control can be performed using the I/O Configurator for NFC.)

b) Input size

Set the number of inputs which can be controlled by the wireless master unit.

Setting range: 0 to 128 points (0 to 16 bytes). Increase or decrease by 16 points.

c) Output size

Set the number of outputs which can be controlled by the wireless master unit.

Setting range: 0 to 128 points (0 to 16 bytes). Increase or decrease by 16 points.

The output size includes the number of points of the valve manifold output.

d) Valve manifold output size

Set the number of outputs to be allocated to the valve manifold output from the number of points set in the Output size.

As the Valve manifold output size is included in the Output size, the number of effective points are limited within the setting range of the Output size.

Setting range: 0 to 32 points (0 to 4 bytes). Increase or decrease by 8 points.

e) Wireless communication

Define the operation status of wireless communication.

Active: Implement the wireless communication.

Idle: Disconnect the wireless communication.

f) Unit address order

Define the address allocation direction of the EX600 I/O units connected to the wireless master unit.

The address allocation direction is selected by changing the mode to Mode 1 or Mode 2. Be careful about the I/O map. (Refer to the section "I/O Map" for details.)

Mode 1: Allocation from the end plate side to the right.

Mode 2: Allocation from the wireless unit side to the left.

(2) System setting

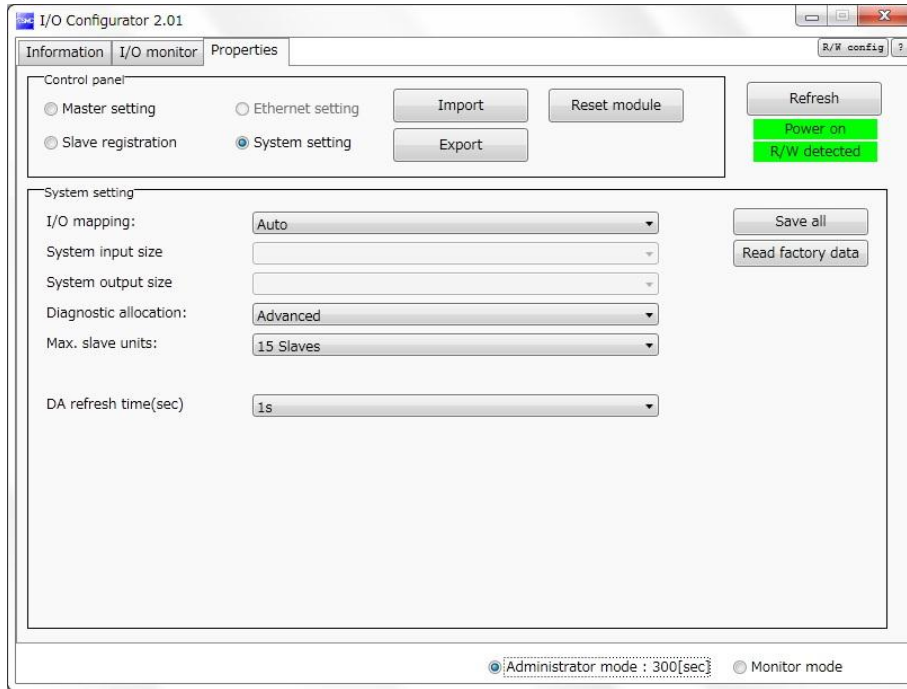

a) I/O mapping

Define the I/O mapping of the entire wireless system including the wireless slave unit registered to the wireless master unit.

Auto mapping: All I/O points mapped to the wireless master unit and wireless slave unit are identified and mapped automatically.

(The total number of connected I/O points is the total number of I/O points connected to the diagnostic information, wireless master and slave unit.)

b) System input size

Set the number of inputs which can be controlled by the entire wireless system.

Setting range: 16 to 1280 points (2 to 160 bytes). Increase or decrease by 128 points.

c) System output size

Set the number of outputs which can be controlled by the entire wireless system.

Setting range: 16 to 1280 points (2 to 160 bytes). Increase or decrease by 128 points.

d) Diagnostic allocation

Set the diagnostic information allocated to the I/O map. (Refer to the section "Diagnostic allocation" for details.)

None: No diagnostic data

Simple: System diagnosis

Detailed: System diagnosis + Wireless slave connection / diagnosis / registration information

e) Max slave units

Set the number of wireless slave units which are registered to the wireless master unit.

Wireless channels for the number of the set units are valid.

Setting range: 0 / 15 / 31 pcs.

f) DA refresh time

Analogue output update time

Set the data update time of the analogue output unit.

Setting range: 0.1/0.2/0.5/1/2/5/10/30/60s

Note) Analogue I/O unit

This product is applicable to the analogue I/O unit.

The initial setting of the update time is 1 second for input and output respectively.

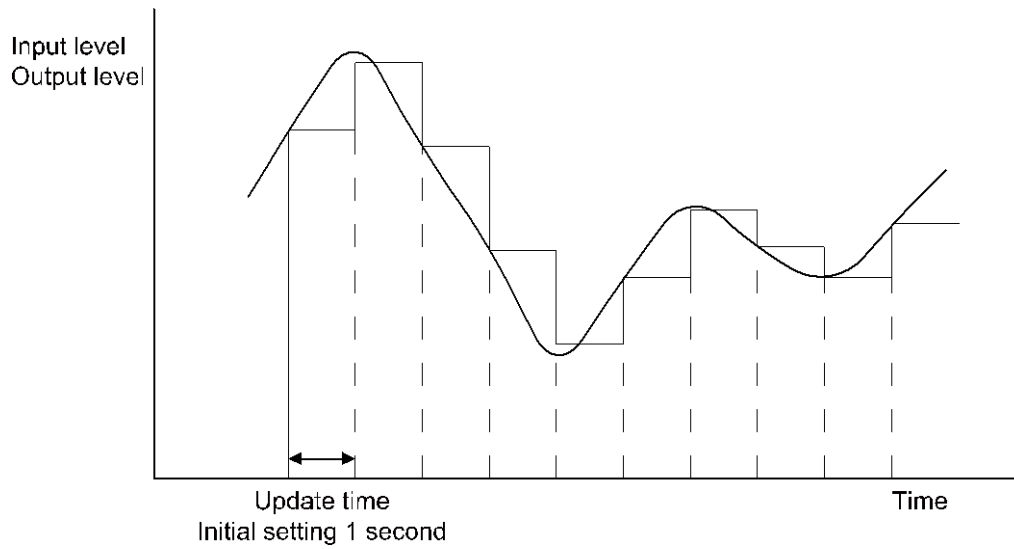

(3) Slave unit registration

Registration for wireless communication between the wireless master unit and the wireless slave unit. For this wireless system, it is necessary to register the PID (Product ID) of each product to establish communication without interference from another network.

The minimum required settings for registration of the wireless master unit are pairing (change of operation mode) and wireless slave unit registration.

Wireless communication can be established even if the dummy slave is not registered. Register the dummy slave as necessary.

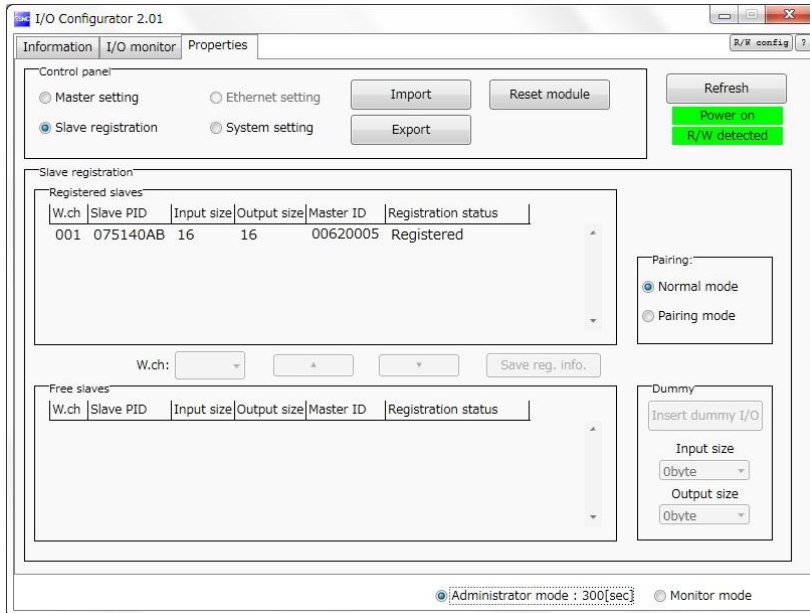

a) Pairing

Select operation mode of the wireless master unit.

The wireless slave unit can be registered only when "Pairing enable" is selected.

Pairing disable: Wireless slave unit cannot be registered (Communication with the registered wireless slave will be established).

Pairing enable: Wireless slave unit and dummy slave can be registered.

b) Slave unit registration

Register and delete the wireless slave unit to/from the wireless master unit; and check the registration status of the wireless slave unit.

Refer to Wireless slave unit registration procedure for details.

c) Dummy

Register the dummy slave to the wireless channel.

Refer to Wireless slave unit registration procedure for details.

•Detailed wireless slave parameters

The following two settings need to be performed to set the parameters of the wireless slave.

- (1) Slave unit setting
- (2) Pairing setting

(1) Slave unit setting

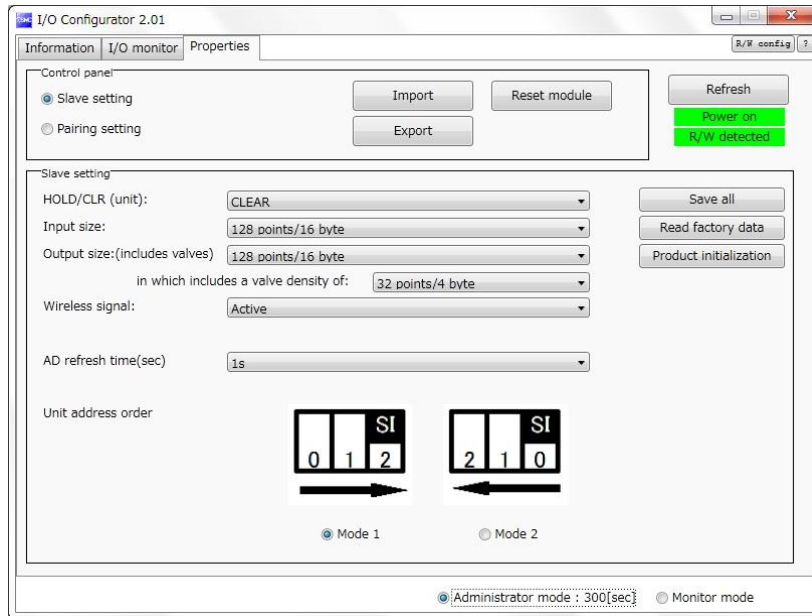

a) Hold / CLR (unit)

Define settings for the output operation status when the PROFINET communication is disconnected.

Clear: Clear the output.

Hold: Fix the output at the current value.

Software control: Clear, Hold or Set can be set by software bit.

(The detailed setting of the Software control can be performed using the I/O Configurator for NFC.)

b) Input size

Set the number of inputs which can be controlled by the wireless slave unit.

Setting range: 0 to 128 points (0 to 16 bytes). Increase or decrease by 16 points.

c) Output size

Set the number of outputs which can be controlled by the wireless slave unit.

Setting range: 0 to 128 points (0 to 16 bytes). Increase or decrease by 16 points.

d) Valve manifold output size

Set the number of outputs to be allocated to the valve manifold output from the number of points set in the Output size.

As the Valve manifold output size is included in the Output size, the number of effective points are limited within the setting range of the Output size.

Setting range: 0 to 32 points (0 to 4 bytes). Increase or decrease by 8 points.

e) Wireless communication

Define the operation status of wireless communication.

Active: Implement the wireless communication.

Idle: Disconnect the wireless communication.

f) AD refresh time

Set the data update time of the analogue input unit.

Setting range: 0.1/0.2/0.5/1/2/5/10/30/60s

g) Unit address order

Define the address allocation direction of the EX600 I/O units connected to the wireless slave unit.

The address allocation direction is selected by changing the mode to Mode 1 or Mode 2. Be careful about the I/O map.

Mode 1: Allocation from the end plate side to the right.

Mode 2: Allocation from the wireless unit side to the left.

(2) Pairing setting

Setting for wireless communication between the wireless master unit and wireless slave unit.

The required setting for wireless registration of the wireless slave unit is Pairing (change of operation mode) only.

After changing the operation mode in the Pairing, the mode is changed by clicking Reset module or by re-supplying power so that the mode will be changed to "Master unit registration" or "Listening for connection".

* : After switching the operation mode with the Pairing setting, check that the W-NS LED on the wireless unit flashes in green and red alternately.

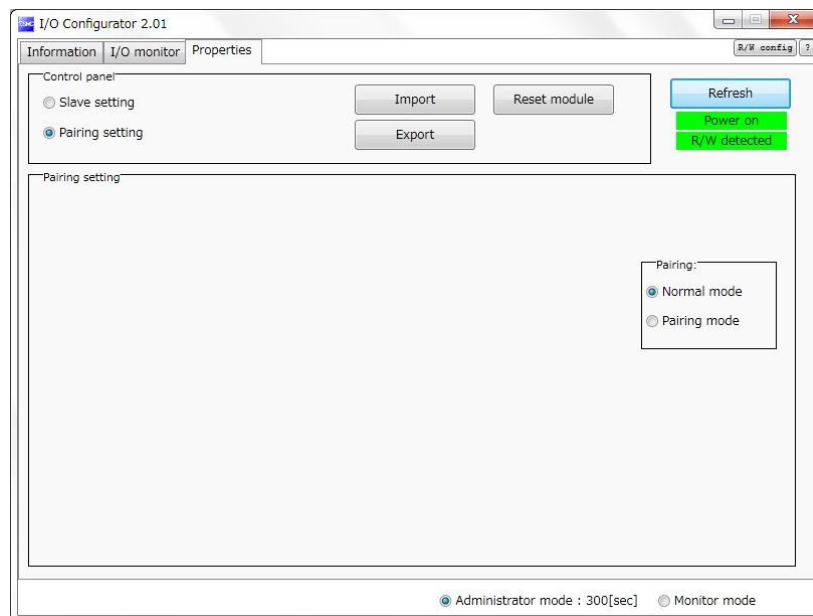

a) Pairing

Select the operation mode of the wireless slave unit.

The wireless master unit can be registered only when "Pairing enable" is selected.

Pairing disable: Wireless slave unit cannot be registered (Communication with the registered wireless slave will be established).

Pairing enable: Wireless slave unit and reserve slave can be registered.

•Wireless unit registration procedure

•Registration procedure for the wireless master unit and the wireless slave unit

(1) **Change of operation mode** of the wireless slave unit

Change the pairing setting of the wireless slave unit to "Pairing enable" and reflect the change by clicking **Reset module** or by re-supplying power.

(2) **Change of operation mode** of the wireless master unit

Change the pairing setting of the slave unit registration of the wireless master unit to "Pairing enable" and reflect the change by clicking **Reset module** or by re-supplying power. Then, update the contents on the screen by clicking **Refresh all**.

(Registered slave unit information will be displayed in the free slave.)

(3) **Selection of wireless channel**

Select the required wireless channel in the slave unit setting of the wireless master unit and select the wireless slave unit to be registered so that items in the box "Slaves to be registered" will be moved to the box "Registered slaves".

(Registration is not complete at this point. The status of the wireless slave unit will be shown as "Waiting for registration".)

(4) **Determination of information to be registered**

Click **Save the wireless slave units** to the wireless master unit.

Then, click **Refresh all** to confirm that the setting has been reflected.

(When registration has been completed correctly, the status of the selected wireless slave unit will change from "Waiting for registration" to "registered".)

(When the wireless slave unit is registered correctly, the mode will change automatically.)

(5) **Change of operation mode** of the wireless master unit

Change the pairing setting on the slave unit registration screen of the wireless master unit to "Pairing disable" and reflect the change by clicking **Reset module** or by re-supplying power.

Now, the registration procedure for the wireless master unit and the wireless slave unit are complete.

When registering more than one wireless slave is required, repeat procedures (3) and (4).

It is also possible to register more than one wireless slave unit simultaneously to the wireless master unit.

•Dummy slave

The dummy slave can register a "Dummy area" in the I/O map. A wireless slave unit can be added without changing the I/O map by registering the wireless slave unit to the "Dummy area" even after system construction.

The wireless slave unit allocation order to the I/O map is from smallest channel to largest channel registered by the wireless channel which has been set during slave unit registration.

At the time, the wireless channel in which no wireless slave unit is registered will be ignored.

When adding new wireless slave units, it may be required to change the I/O map depending on the wireless channel number.

The dummy slave can be registered only with the wireless master unit.

•Dummy slave registration

(1) **Change of operation mode** of the wireless master unit

Change the pairing setting of the slave unit registration of the wireless master unit to "Pairing enable" and reflect the change by clicking **Reset module** or by re-supplying power. Then, update the contents on the screen by clicking **Refresh all**.

(2) **Inputs / outputs setting** of dummy slave

Set the number of inputs and outputs of the dummy slave.

(3) **Allocation** of the dummy slave **to the required wireless channel**

Select the required wireless channel and click **Insert** so that the set dummy slave is displayed in the box "Registered slaves".

(Dummy slave registration is not complete at this point. The status is "Waiting for registration".)

(4) **Determination** of dummy slave **registration information**

Click **Save reg-info** to reflect the registered information.

(When registration has been completed correctly, the status of the dummy slave will change to "registered".)

Now, the registration procedure for the dummy slave are complete.

■ Dimensions

•EX600-WPN#

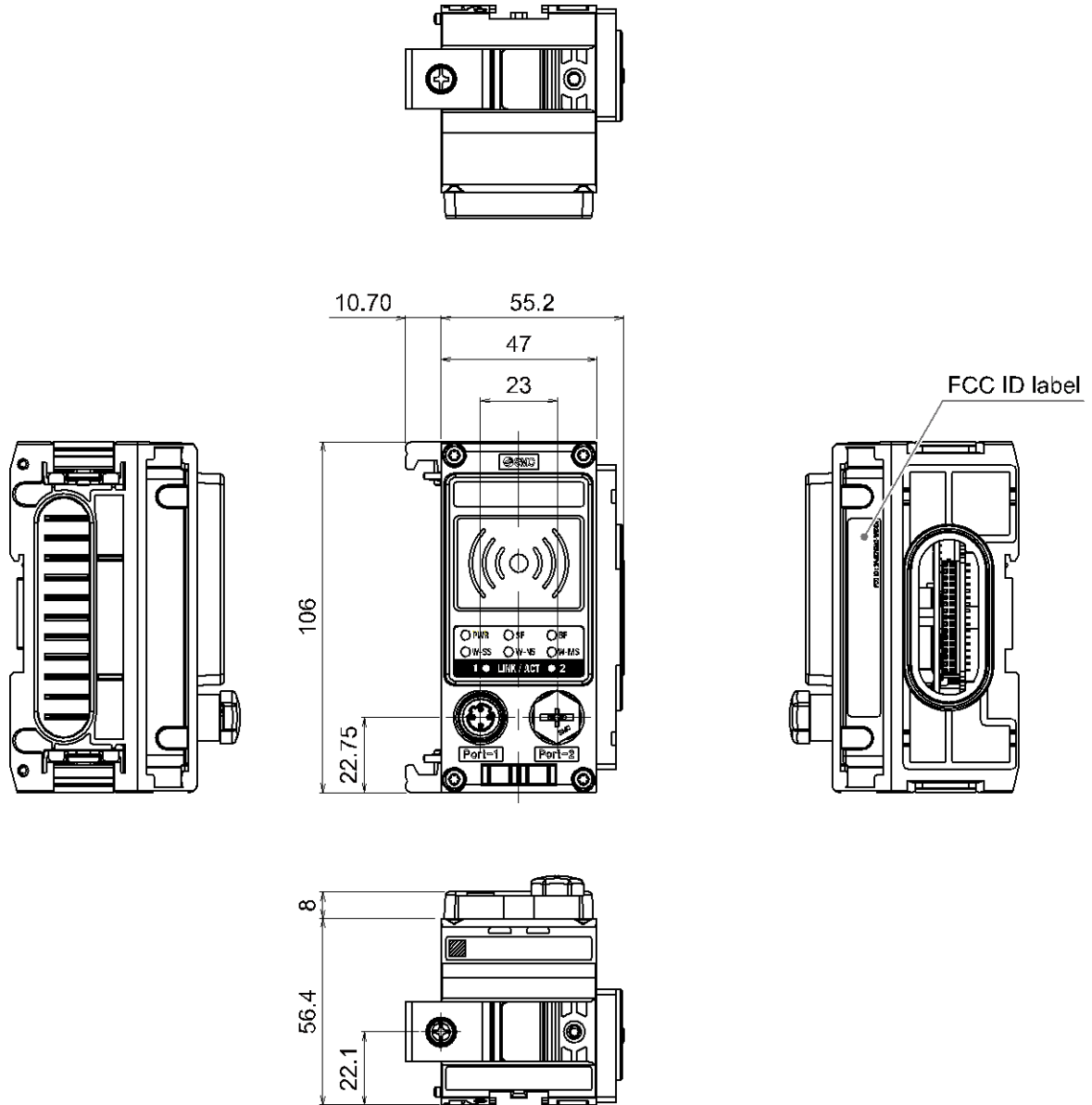

•EX600-WSV#

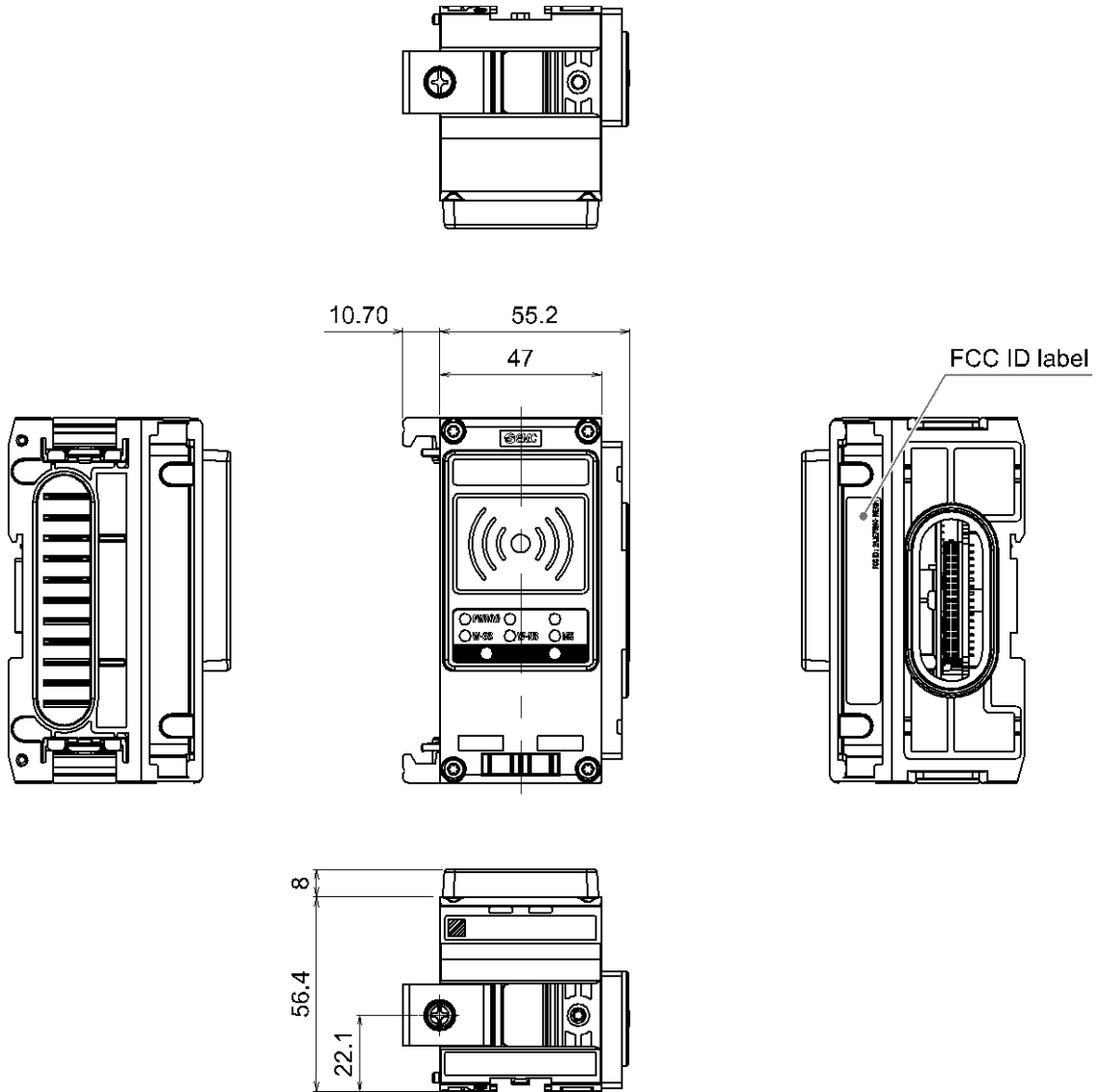

Hardware Configuration

■ GSDML file and icons

A GSDML file is required to configure the EX600 with a PROFINET controller (PLC). At the same time, a special icon file is required to display the icon for EX600 in the software of the PLC.

- GSDML File : GSDML-V2.32-SMC-EX600-WPN-***.xml
- Icon file : GSDML-0083-0010-EX600_WPN.bmp

■ Configuration layout

The I/O map of the EX600 is assigned in the following order, diagnostic data, wireless master module and then wireless slave modules. The wireless slave module allocation order to the I/O map is decided by the wireless channel at the slave unit registration. As they are allocated from the smallest registered channel number, the channel in which no wireless slave is registered will be ignored (Refer to the figure below). Therefore it is necessary to perform configurations correctly in the order of the wireless channels with a configuration programme to ensure correct communication with the PLC.

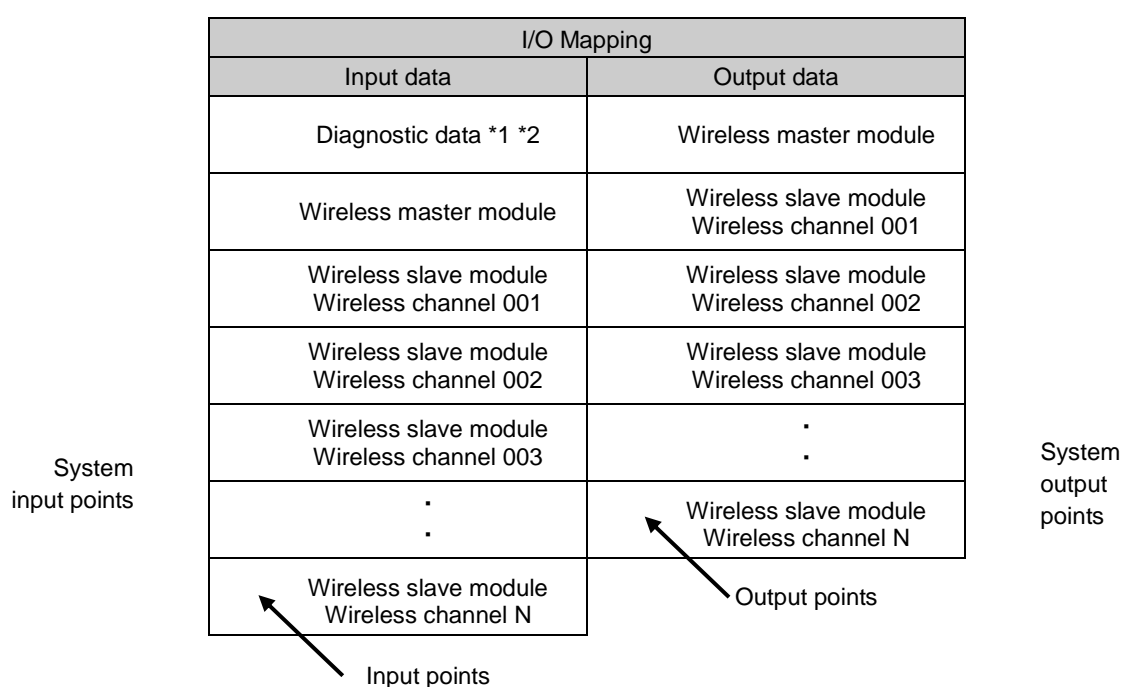

*1: Can be altered with the wireless master unit's diagnostic allocation settings under parameters.

Refer to diagnostic allocation section for details

*2: As default, the diagnostic data allocation within step 7 starts from address 256

■ Connection to SIEMENS PLC S7

How to connect the EX600 series to SIEMENS PLC is explained below.
Refer to the Operation Manual of the STEP7™ for the detailed operation.

* The drawing below shows the SIEMENS software, STEP7™ V5.5.

•GSDML file installation

- (1) Open **HW Config** screen.
- (2) Select **Options** → **Install GSD File...** in menu bar.
- (3) **[Install GSD Files** screen will be displayed. Select the folder in which the GSDML file is stored.
- (4) A list of stored GSDML files will be displayed. Select the file to install, and press [Install].
- (5) EX600-WPN# hardware component will be added to **Hardware Catalog** window folder.
(PROFINET IO \Additional Field Devices \Valves \SMC EX600)

•**Device Name assignment**

- (1) Connect the EX600 system to the PLC.
- (2) Select **PLC** → **Ethernet** → **Edit Ethernet Node** from the menu bar of **HW Config**.

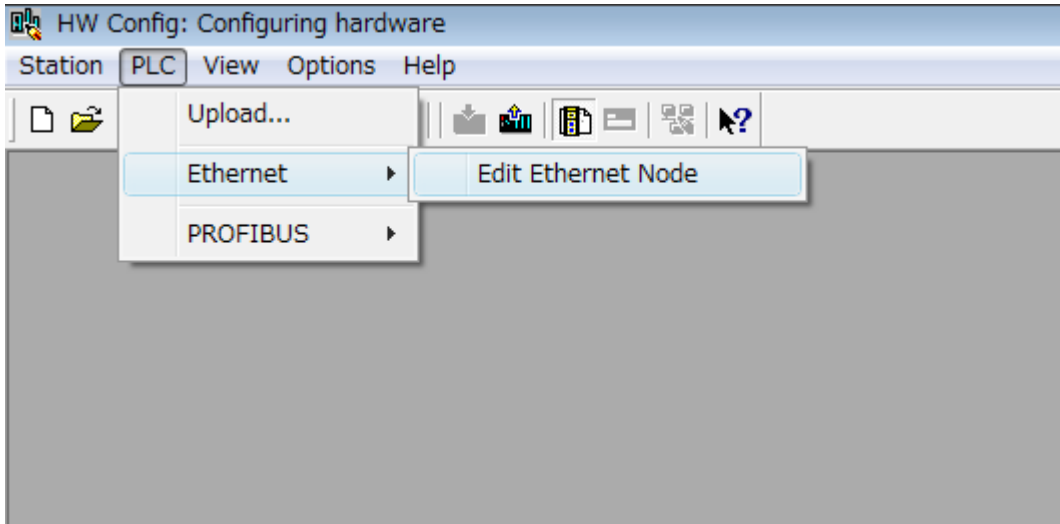

- (3) **Edit Ethernet Node** screen will be displayed. Press the **Browse** button.
- (4) **Browse Network** screen will be displayed. The list of equipment in the same network will be displayed. Select Wireless Master MAC address for assigning Device Name.
- (5) Press the **OK** button.

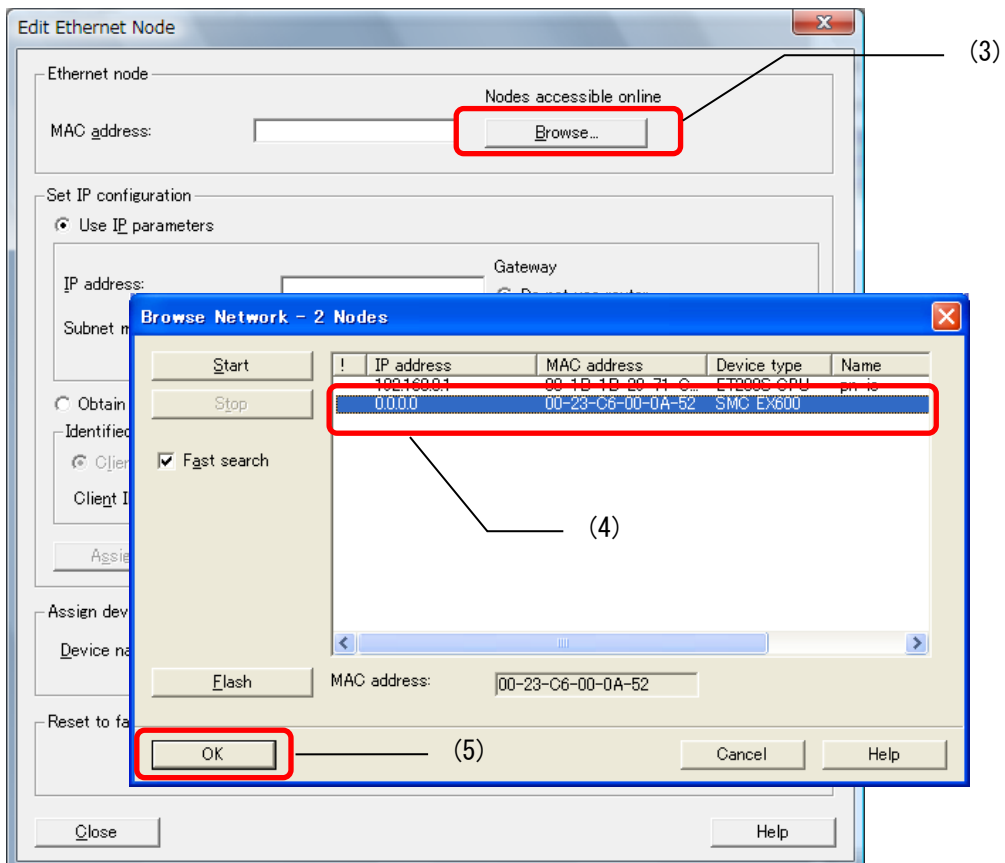

- (6) **Edit Ethernet Node** will be displayed with Wireless Master unit MAC address. Enter the intended **Device name** for the wireless master unit .
(7) Press the **Assign Name** button.

The screenshot shows the 'Edit Ethernet Node' dialog box with the following fields and controls:

- Ethernet node**: MAC address: 00-23-C6-00-0A-52, Nodes accessible online: Browse...
- Set IP configuration**:
 - Use IP parameters:
 - IP address: []
 - Subnet mask: []
 - Gateway: Do not use router, Use router (Address: [])
 - Obtain IP address from a DHCP server
- Identified by**:
 - Client ID, MAC address, Device name
 - Client ID: []
-
- Assign device name**:
 - Device name: ex600-wpn (highlighted with a red box)
 -
- Reset to factory settings**:
-

Callout (6) points to the 'Assign Name' button. Callout (7) points to the 'Device name' field.

Adding a device

- (1) Drag EX600-WPN# from **HW Config** screen **Hardware Catalog** window, and drop it onto the **PROFINET-IO-System** line.
- (2) The EX600 icon will be added to the line. Double-click the EX600 icon, or place the cursor on the icon and right-click it to select **Object Properties ---**.
- (3) The Properties screen is displayed. Enter the same name which was set by **Edit Ethernet Node** screen into the **Device name** box.
- (4) Ensure that the box for **Assign IP address via IO controller** is ticked.
Note: The MAC address is written on the product-side label.
- (5) Press the [OK] button.

The image shows a sequence of steps in the SIMATIC Manager software:

- Hardware Catalog:** A window showing a list of components. The **EX600-WPN#** device is highlighted and dragged towards the main configuration area.
- Hardware Configuration:** The main workspace shows a **PROFINET-IO-System (100)** connected to an **IM151-8 PN/DP CPU**. The **EX600-WPN#** device is added to the system line.
- Properties - EX600-WPN:** A dialog box for configuring the device. The **Device name** field is set to **ex600-wpn**. The **Assign IP address via IO controller** checkbox is checked. The **OK** button is highlighted.

Adding EX600 modules

(1) From the **HW Config** screen click the EX600-WPN icon.

(2) In the **Configuration table** window, an empty slot for EX600-WPN# will be displayed.

(3) In the Hardware Catalog window, open the Diagnosis folder and choose the required diagnostic option.. Select a diagnostic option according to the diagnostic allocation and the number of connected wireless slave units. Then drag and drop into **Slot 1** in the **Configuration table** window.

Important: Always use Slot 1 for diagnostic data

- No diagnosis --- Diagnostic allocation: None
- Diagnosis --- Diagnostic allocation: Simple
- Diagnosis 015 ---Diagnostic allocation: Detailed, number of connected wireless slave units: 15 pcs
- Diagnosis 031 --- Diagnostic allocation: Detailed, number of connected wireless slave units: 31 pcs

Please note that options for selection of Diagnosis 063 or 127 are given, but they are not supported. Do not select them

(4) In the Hardware Catalog window, open the Wireless Master Units folder and select the required input size based on the number of wireless master unit input points (0, 2, 4...16 bytes). Thendrag and drop into **Slot 2** in the **Configuration table** window. Similarly, select the required output size based on the number of wireless master unit output points (0, 2, 4...16 bytes). Then drag and drop into Slot 3 in the **Configuration table** window.

(5) From the **Hardware Catalog** window, open the Wireless Slave Units folder and select the required input size based on the number of input points (0, 2, 4...16 bytes) of the wireless slave unit registered on the lowest wireless channel. Then drag and drop into **Slot 6** in the **Configuration table** window. Similarly, from the **Hardware Catalog** window, select the required output size based on the number of output points (0, 2, 4...16 bytes) of the wireless slave unit registered on the lowest wireless channel. Then drag and drop into **Slot 7** in the **Configuration table** window. The input and ouput of any other wireless slave units should be dragged and dropped into a slot in the order of the lowest wireless channel, alternating between input and output.

The screenshot shows the HW Config interface for a SIMATIC 300 system. The main window displays a rack configuration with a CPU and the EX600-WPN module. A table below shows the module's slots and their addresses. On the right, a tree view shows the module's internal components, including diagnosis, wireless master units, and wireless slave units. Red boxes and arrows highlight specific components and their corresponding table entries.

Slot	Module	Order number	Address	Q address	Diagnostic address	Comment
0	EX600-WPN	EX600-WPN			2042*	
X1	Interface				2041*	
P1	Part 1				2040*	
P2	Part 2				2039*	
1	Diagnosis 015		256..265			
2	EX600-WPN# In16	EX600-WPN	0..15			
3	EX600-WPN# Out16	EX600-WPN		0..15		
4	EX600-WSV# In08	EX600-WSV	16..23			
5	EX600-WSV# Out08	EX600-WSV		16..23		
6	EX600-WSV# In16	EX600-WSV	24..39			
7	EX600-WSV# Out16	EX600-WSV		24..39		

Overview of HW config example

Slot	Module	Description
1	Diagnosis 015	Detailed Diagnosis data for upto 15 connected wireless slaves
2	EX600-WPN# In16	16 bytes of input data for Wireless Master module
3	EX600-WPN# Out16	16 bytes of output data for Wireless Master module
4	EX600-WSV# In08	8 bytes of input data for Wireless Slave module registered to wireless channel 001
5	EX600-WSV# Out08	8 bytes of output data for Wireless Slave module registered to wireless channel 001
6	EX600-WSV# In16	16 bytes of input data for Wireless Slave module registered to wireless channel 002
7	EX600-WSV# Out16	16 bytes of output data for Wireless Slave module registered to wireless channel 002

•FSU (Fast Start Up) settings

The EX600 supports the FSU function.

To enable the FSU function, it is necessary to change the FSU settings of the connected PLC.

PLC FSU set up

- (1) The **Properties** screen will be displayed by double-clicking the **PLC PROFINET** port in the **HW Config** screen, which is connected to the EX600.
- (2) Select the **Options** tab.
- (3) In the Connection screen, select **TP 100Mbps full duplex** from drop down list. .
- (4) Tick the box for **Disable autonegotiation**.
- (5) Press the **OK** button.

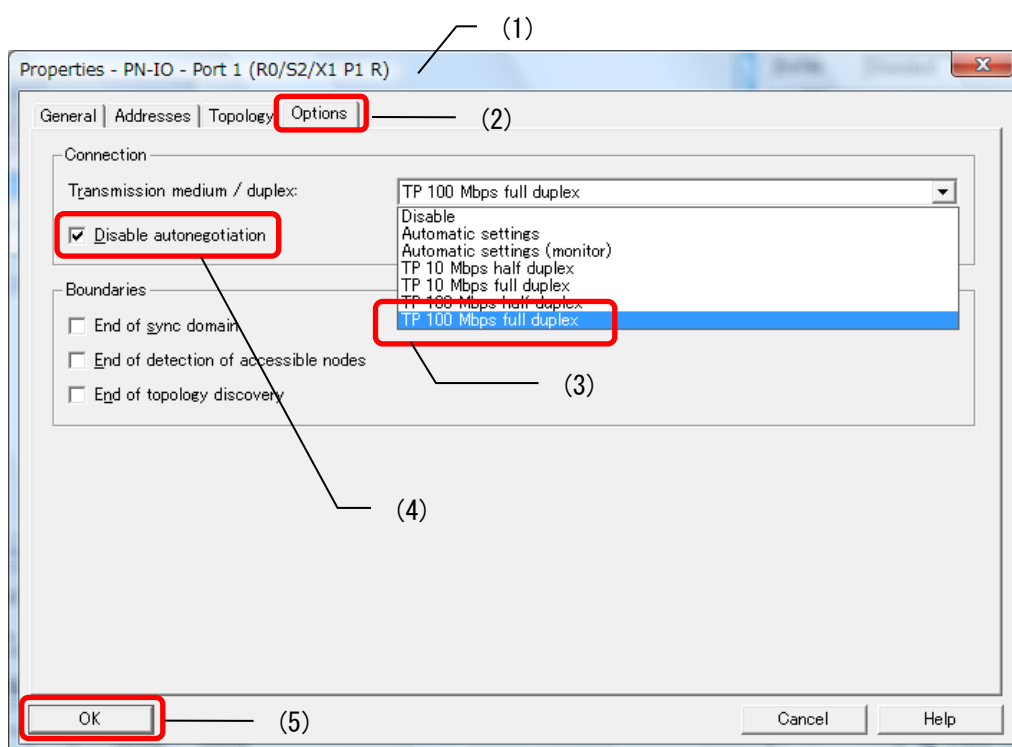

EX600 FSU setup

- (1) Click the EX600-WPN# icon in the **HW Config** screen.
- (2) The **Properties** screen will be displayed by double-clicking the **Interface** of the **Configuration table** window **Slot X1**.
- (3) In the General Tab, tick the box for **Prioritized startup**.
- (4) Press the **OK** button.

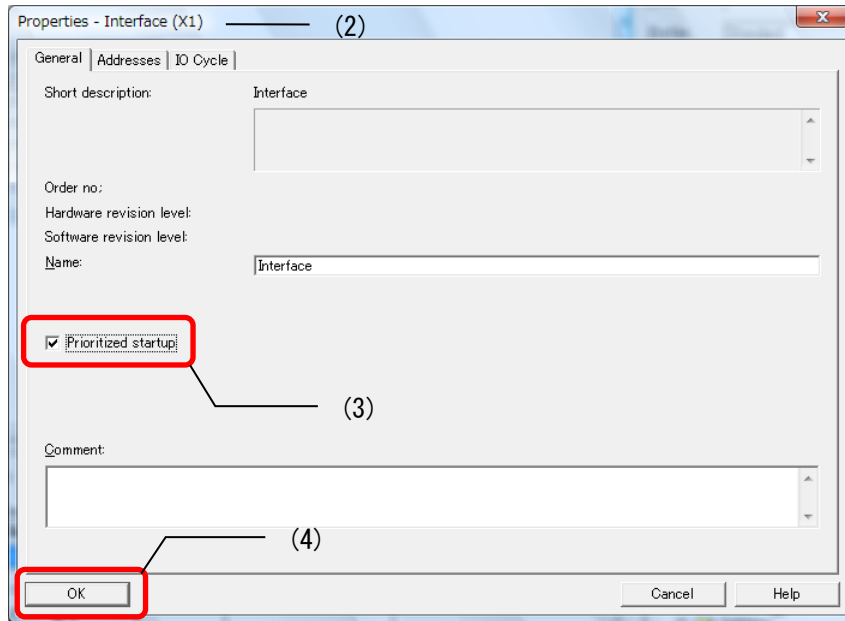

- (5) The **Properties** screen will be displayed by double-clicking the **Slot1 P1** or **P2** (communication port using the FSU function) in the **HW Config** screen.
- (6) Select the **Options** tab.
- (7) In the Connection screen, select **TP 100Mbps full duplex** from drop down list.
- (8) Tick the box for **Disable autonegotiation**.
- (9) Press the **OK** button.

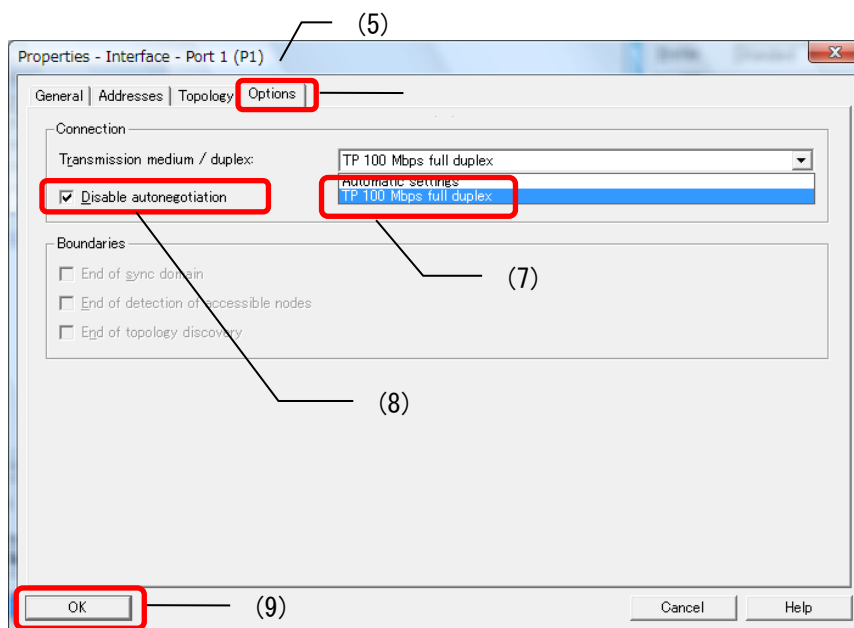

Wiring

In order to enable the FSU function, it is necessary to disable autonegotiation and shorten the set time value. In this case, Port 1 will be fixed as MDI and Port 2 as MDIX.

The wiring connection procedure is shown below. For PLC connection procedure, refer to the specifications of the PLC in use.

Case 1 (Patch cable)

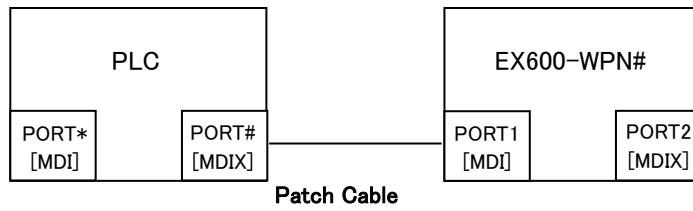

OR

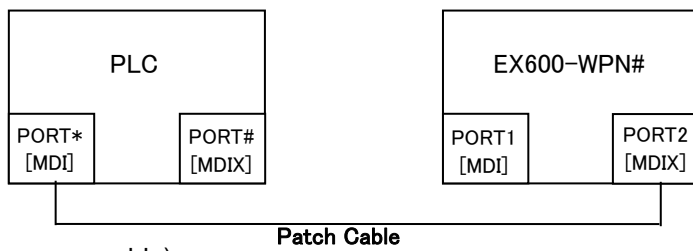

Case 2 (Crossover cable)

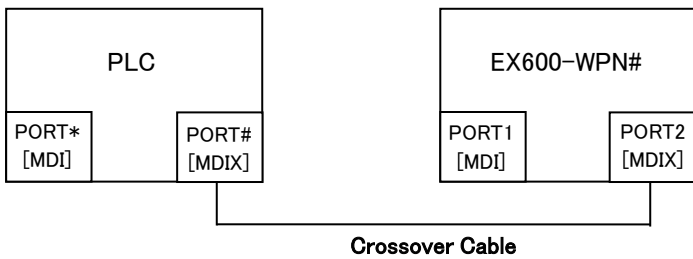

OR

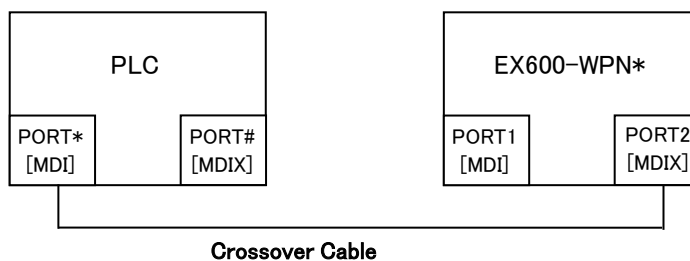

I/O Map

The table below shows the number of occupied bytes for each input/output unit of EX600 which can be connected to the wireless master and wireless slave units.

The allocated input/output sizes can be changed depending on the occupied bytes of the diagnostic allocation and the EX600 I/O unit connected to the wireless unit.

Refer to the table below for the number of input/output bytes for each unit.

Unit name	Model	Unit product No.	I/O Occupation area	
			Input	Output
Wireless unit	WPN WSV	EX600-W### (32 points)	0 *1	4
		EX600-W### (24 points)	0 *1	3
		EX600-W### (16 points)	0 *1	2
		EX600-W### (8 points)	0 *1	1
		EX600-W### (0 point)	0 *1	0
Digital input unit	DX	EX600-DX#B (8 points)	1	0
		EX600-DX#C (8 points)	1	0
		EX600-DX#D (16 points)	2	0
		EX600-DX#E (16 points)	2	0
		EX600-DX#F (16 points)	2	0
Digital output unit	DY	EX600-DY#B (8 points)	0	1
		EX600-DY#E (16 points)	0	2
		EX600-DY#F (16 points)	0	2
Digital I/O unit	DM	EX600-DM#E (8/8 points)	1	1
		EX600-DM#F (8/8 points)	1	1
Analogue input unit	AX	EX600-AXA*2 (2 points)	4	0
Analogue output unit	AY	EX600-AYA*2 (2 points)	0	4
Analogue I/O unit	AM	EX600-AMB*2 (2/2 points)	4	4

*1: The occupied bytes of input of the wireless unit (EX600-W###) will vary depending on the setting of the diagnostic allocation. Refer to the section "Diagnostic allocation" for details.

*2: The minus ranges of the user setting are not supported.

■ I/O mapping order of wireless master / slave module

Please note that the allocation order of the EX600 I/O unit and the valve manifold connected to the wireless master unit or slave unit is different depending on the I/O unit layout mode in the wireless system parameter setting.

Mode 1: **Allocation from the end plate side to the right.**

Mode 2: **Allocation from the wireless unit side to the left.**

I/O mapping examples in Mode 1 and Mode 2 are shown below.

<Example 1>

● Mode 1

	Unit 0	Unit 1	Unit 2	
End plate	DY#B Digital output 1-byte output	DX#D Digital input 2-byte output	EX600-WPN# Wireless master unit 2-byte output	Valve manifold (16 points)

Wireless master unit setting parameter
 Diagnostic allocation: None / Simple / Detailed
 I/O mapping: Auto
 Input size: 32 points / 4 bytes
 Output size: 32 points / 4 bytes
 Valve manifold output size: 16 points / 2 bytes
 I/O unit layout mode: Mode 1
 Number of slave connection: 15 pcs.

Wireless master module construction

Input data: [Unit 1] Digital input unit (EX600-DX#D): 2 bytes occupied
 Output data: [Unit 0] Digital output unit (EX600-DY#B): 1 byte occupied
 [Unit 2] Wireless master unit (EX600-WPN#): 2 bytes occupied

	Unit 0	Unit 1	Unit 2	Unit 3	
End plate	DY#B Digital output 1-byte output	AXA Analogue input 4-byte input	DX#D Digital input 2-byte input	EX600-WSV# Wireless slave unit 4-byte output	Valve manifold (32 points)

Wireless slave unit setting parameter
 (Wireless channel 001)
 Input size: 64 points / 8 bytes
 Output size: 48 points / 6 bytes
 Valve manifold output size: 32 points / 4 bytes
 I/O unit layout mode: Mode 1

Wireless slave module construction (Wireless channel 001)

Input data: [Unit 1] Analogue input unit (EX600-AXA): 4 bytes occupied
 [Unit 2] Digital input unit (EX600-DX#D): 2 bytes occupied
 Output data: [Unit 0] Digital output unit (EX600-DY#B): 1 byte occupied
 [Unit 3] Wireless slave unit (EX600-WSV#): 4 bytes occupied

	Unit 0	Unit 1	Unit 2	Unit 3	
End plate	DY#B Digital output 1-byte output	DX#D Digital input 2-byte input	DX#B Digital input 1-byte input	EX600-WSV# Wireless slave unit 0-byte output	End plate (Output side)

Wireless slave unit setting parameter
 (Wireless channel 002)
 Input size: 32 points / 4 bytes
 Output size: 16 points / 2 bytes
 Valve manifold output size: 0 point / 0 byte
 I/O unit layout mode: Mode 1

Wireless slave module construction (Wireless channel 002)

Input data: [Unit 1] Digital input unit (EX600-DX#D): 2 bytes occupied
 [Unit 2] Digital input unit (EX600-DX#B): 1 byte occupied
 Output data: [Unit 0] Digital output unit (EX600-DY#B): 1 byte occupied
 [Unit 3] Wireless slave unit (EX600-WSV#): 0 byte occupied

•Diagnostic allocation: None

	Input data		Output data	
	Module name	Unit name	Module name	Unit name
byte 0	Wireless master module	DX#D (Unit 1) Reserved Reserved	Wireless master module	DX#B (Unit 0)
byte 1				EX600-WPN# (Unit 2) Valve output: 16 points
byte 2				Reserved
byte 3				Reserved
byte 4	Wireless slave module (Wireless channel 001)	AXA (Unit 1) DX#D (Unit 2) Reserved Reserved	Wireless slave module (Wireless channel 001)	DY#B (Unit 0)
byte 5				EX600-WSV# (Unit 3) Valve output: 32 points
byte 6				Reserved
byte 7				Reserved
byte 8				Reserved
byte 9				Reserved
byte 10				Reserved
byte 11	Wireless slave module (Wireless channel 002)	DX#D (Unit 1) DX#B (Unit 2) Reserved	Wireless slave module (Wireless channel 002)	DY#B (Unit 0)
byte 12				Reserved
byte 13				Reserved
byte 14				Reserved
byte 15				
Total	16 byte		12 byte	

•Diagnostic allocation: Simple

	Input data		Output data				
	Module name	Unit name	Module name	Unit name			
byte 0	System diagnosis 1	System diagnosis 2	Wireless master module	DY#B (Unit 0)			
byte 1				EX600-WPN# (Unit 2) Valve output: 16 points			
byte 2				Reserved			
byte 3				Reserved			
byte 4	Wireless master module	DX#D (Unit 1) Reserved Reserved	Wireless slave module (Wireless channel 001)	DY#B (Unit 0)			
byte 5				EX600-WSV# (Unit 3) Valve output: 32 points			
byte 6				Reserved			
byte 7				Reserved			
byte 8				Reserved			
byte 9				Reserved			
byte 10				Reserved			
byte 11	Wireless slave module (Wireless channel 001)	AXA (Unit 1) DX#D (Unit 2) Reserved Reserved	Wireless slave module (Wireless channel 002)	DY#B (Unit 0)			
byte 12				Reserved			
byte 13				Reserved			
byte 14				Reserved			
byte 15				Reserved			
byte 16				Wireless slave module (Wireless channel 002)	DX#D (Unit 1) DX#B (Unit 2) Reserved	Wireless slave module (Wireless channel 002)	DY#B (Unit 0)
byte 17							Reserved
byte 18	Reserved						
byte 19	Reserved						
Total	20 byte		12 byte				

•Diagnostic allocation: Detailed

	Input data		Output data	
	Module name	Unit name	Module name	Unit name
byte 0	System diagnosis 1		Wireless master module	DY#B (Unit 0)
byte 1	System diagnosis 2			EX600-WPN# (Unit 2) Valve output: 16 points
byte 2	System diagnosis 3			Reserved
byte 3	System diagnosis 4			
byte 4	Wireless slave connection information (Wireless channel 1-7; bit 0 are fixed at "0".)		Wireless slave module (Wireless channel 001)	DY#B (Unit 0)
byte 5	Wireless slave connection information (Wireless channel 8-15)			EX600-WSV# (Unit 3) Valve output: 32 points
byte 6	Wireless slave diagnostic information*1 (Wireless channel 1-7)			
byte 7	Wireless slave diagnostic information (Wireless channel 8-15)			
byte 8	Wireless slave registration information (Wireless channel 1-7; bit 0 are fixed at "0".)			
byte 9	Wireless slave registration information (Wireless channel 8-15)			
byte 10	Wireless master module	DX#D (Unit 1)	Wireless slave module (Wireless channel 002)	DY#B (Unit 0)
byte 11		Reserved		Reserved
byte 12		Reserved		
byte 13			/	
byte 14	Wireless slave module (Wireless channel 001)	AXA (Unit 1)		
byte 15				
byte 16				
byte 17				
byte 18		DX#D (Unit 2)		
byte 19		Reserved		
byte 20	Reserved			
byte 21				
byte 22	Wireless slave module (Wireless channel 002)	DX#D (Unit 1)		
byte 23				
byte 24		DX#B (Unit 2)		
byte 25		Reserved		
Total	26 byte			

*: When the setting of diagnostic allocation is "Detailed", areas of the number of slaves set at the Number of slave connection are occupied. (The occupied area also occupies the area for wireless slave unit which has not been registered.)

*1: The wireless slave diagnostic information bit 0 indicates the diagnostic information of the master.

•Diagnosis allocation: None

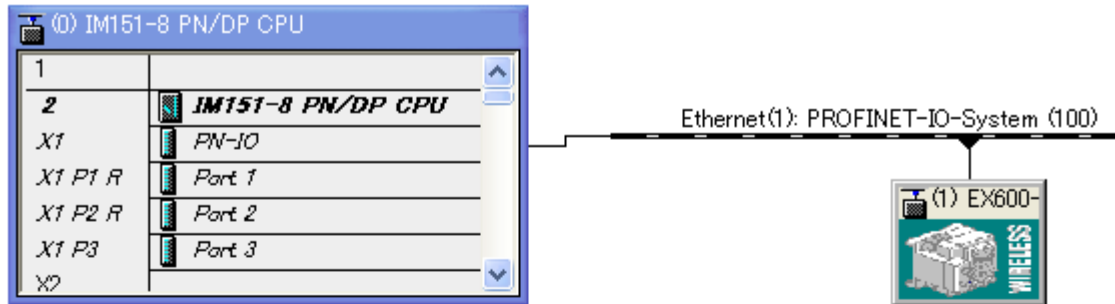

(1) EX600-WPN

Sl..	Module	Order number	I address	Q address	Diagnostic address:	Comment
0	EX600-WPN	EX600-WPN			2042*	
X1	Interface				2041*	
P1	Part 1				2040*	
P2	Part 2				2039*	
1	No Diagnosis	No Diagnosis			2038*	
2	EX600-WPN# In04	EX600-WPN	0..3			
3	EX600-WPN# Out04	EX600-WPN		0..3		
4	EX600-WSV# In08	EX600-WSV	4..11			
5	EX600-WSV# Out06	EX600-WSV		4..9		
6	EX600-WSV# In04	EX600-WSV	12..15			
7	EX600-WSV# Out02	EX600-WSV		10..11		
8						
9						

•Diagnosis allocation: Simple diagnosis

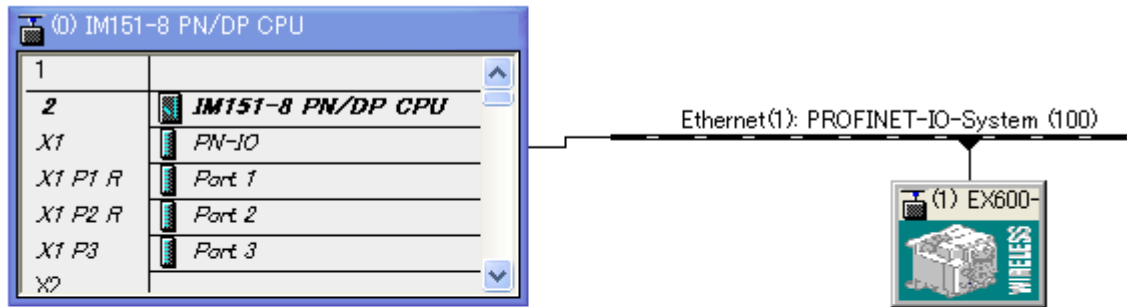

Sl..	Module	Order number	I address	Q address	Diagnostic address:	Comment
0	EX600-WPN	EX600-WPN			2042*	
X1	Interface				2041*	
P1	Part 1				2040*	
P2	Part 2				2039*	
1	Diagnosis	Diagnosis	256...259			
2	EX600-WPN# In04	EX600-WPN	0...3			
3	EX600-WPN# Out04	EX600-WPN		0...3		
4	EX600-WSV# In08	EX600-WSV	4...11			
5	EX600-WSV# Out06	EX600-WSV		4...9		
6	EX600-WSV# In04	EX600-WSV	12...15			
7	EX600-WSV# Out02	EX600-WSV		10...11		
8						
9						

•Diagnosis allocation: Detailed diagnosis

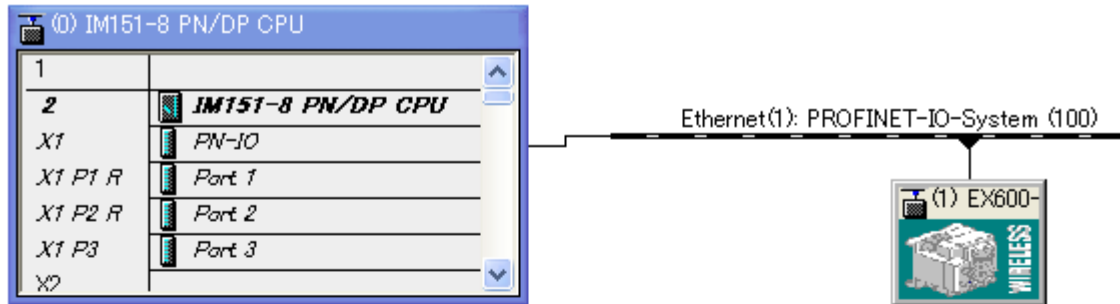

Sl...	Module	Order number	I address	Q address	Diagnostic address:	Comment
0	EX600-WPN	EX600-WPN			2042*	
X1	Interface				2041*	
P1	Part 1				2040*	
P2	Part 2				2039*	
1	Diagnosis 015	Diagnosis	256...265			
2	EX600-WPN# In04	EX600-WPN	0...3			
3	EX600-WPN# Out04	EX600-WPN		0...3		
4	EX600-WSV# In08	EX600-WSV	4...11			
5	EX600-WSV# Out06	EX600-WSV		4...9		
6	EX600-WSV# In04	EX600-WSV	12...15			
7	EX600-WSV# Out02	EX600-WSV		10...11		
8						
9						

<Example 2>

•Mode 2

	Unit 2	Unit 1	Unit 0	
End plate	DY#B	DX#D	EX600-WPN#	Valve manifold (16 points)
	Digital output	Digital input	Wireless master unit	
	1-byte output	2-byte input	2-byte output	

Wireless master unit setting parameter

Diagnostic allocation: None / Simple / Detailed
I/O mapping: Auto

Input size: 32 points / 4 bytes

Output size: 32 points / 4 bytes

Valve manifold output size: 16 points / 2 bytes

I/O unit layout mode: Mode 2

Number of slave connection: 15 pcs.

Wireless master module construction

Input data: [Unit 1] Digital input unit (EX600-DX#D): 2 bytes occupied

Output data: [Unit 0] Wireless master unit (EX600-WPN#): 2 bytes occupied

[Unit 2] Digital output unit (EX600-DY#B): 1 byte occupied

	Unit 3	Unit 2	Unit 1	Unit 0	
End plate	DY#B	AXA	DX#D	EX600-WSV#	Valve manifold (32 points)
	Digital output	Analogue input	Digital input	Wireless slave unit	
	1-byte output	4-byte input	2-byte input	4-byte output	

Wireless slave unit setting parameter (Wireless channel 001)

Input size: 64 points / 8 bytes

Output size: 48 points / 6 bytes

Valve manifold output size: 32 point / 4 byte

I/O unit layout mode: Mode 2

Wireless slave module construction (Wireless channel 001)

Input data: [Unit 1] Digital input unit (EX600-DX#D): 2 bytes occupied

[Unit 2] Analogue input unit (EX600-AXA): 4 bytes occupied

Output data: [Unit 0] Wireless slave unit (EX600-WSV#): 4 bytes occupied

[Unit 3] Digital output unit (EX600-DY#B): 1 byte occupied

	Unit 3	Unit 2	Unit 1	Unit 0	
End plate	DY#B	DX#D	DX#B	EX600-WSV#	End plate (Output side)
	Digital output	Digital input	Digital input	Wireless slave unit	
	1-byte output	2-byte input	1-byte input	0-byte output	

Wireless slave unit setting parameter (Wireless channel 002)

Input size: 32 points / 4 bytes

Output size: 16 points / 2 bytes

Valve manifold output size: 0 point / 0 byte

I/O unit layout mode: Mode 2

Wireless slave module construction (Wireless channel 002)

Input data: [Unit 1] Digital input unit (EX600-DX#D): 2 bytes occupied

[Unit 2] Digital input unit (EX600-DX#B): 1 byte occupied

Output data: [Unit 0] Wireless slave unit (EX600-WSV#): 0 bytes occupied

[Unit 3] Digital output unit (EX600-DY#B): 1 byte occupied

•Diagnostic allocation: None

	Input data		Output data		
	Module name	Unit name	Module name	Unit name	
byte 0	Wireless master module	DX#D (Unit 1)	Wireless master module	EX600-WPN# (Unit 0) Valve output: 16 points	
byte 1		Reserved		DY#B (Unit 2)	
byte 2		Reserved		Reserved	
byte 3					
byte 4	Wireless slave module (Wireless channel 001)	DX#D (Unit 1)	Wireless slave module (Wireless channel 001)	EX600-WSV# (Unit 0) Valve output: 32 points	
byte 5		AXA (Unit 2)		Wireless slave module (Wireless channel 002)	DY#B (Unit 3)
byte 6					Reserved
byte 7		Reserved		Wireless slave module (Wireless channel 002)	DY#B (Unit 3)
byte 8					Reserved
byte 9					
byte 10					
byte 11					
byte 12	Wireless slave module (Wireless channel 002)	DX#B (Unit 1)			
byte 13		DX#D (Unit 2)			
byte 14		Reserved			
byte 15		Reserved			
Total	16 byte		12 byte		

•Diagnostic allocation: Simple

	Input data		Output data		
	Module name	Unit name	Module name	Unit name	
byte 0	System diagnosis 1		Wireless master module	EX600-WPN# (Unit 0) Valve output: 16 points	
byte 1	System diagnosis 2			DY#B (Unit 2)	
byte 2	System diagnosis 3			Reserved	
byte 3	System diagnosis 4				
byte 4	Wireless master module	DX#D (Unit 1)	Wireless slave module (Wireless channel 001)	EX600-WSV# (Unit 0) Valve output: 32 points	
byte 5		Reserved		DY#B (Unit 3)	
byte 6		Reserved		Reserved	
byte 7	Wireless slave module (Wireless channel 001)	DX#D (Unit 1)	Wireless slave module (Wireless channel 002)	DY#B (Unit 3)	
byte 8				Reserved	
byte 9		AXA (Unit 2)		DY#B (Unit 3)	
byte 10				Reserved	
byte 11		Reserved		Reserved	Reserved
byte 12					
byte 13					
byte 14	Wireless slave module (Wireless channel 002)	DX#B (Unit 1)			
byte 15		DX#D (Unit 2)			
byte 16		Reserved			
byte 17		Reserved			
byte 18					
byte 19					
Total	20 byte		12 byte		

•Diagnostic allocation: Detailed

	Input data		Output data		
	Module name	Unit name	Module name	Unit name	
byte 0	System diagnosis 1		Wireless master module	EX600-WPN# (Unit 0) Valve output: 16 points	
byte 1	System diagnosis 2				
byte 2	System diagnosis 3				
byte 3	System diagnosis 4				
byte 4	Wireless slave connection information (Wireless channel 1-7; bit 0 are fixed at "0".)		Wireless slave module (Wireless channel 001)	EX600-WSV# (Unit 0) Valve output: 32 points	
byte 5	Wireless slave connection information (Wireless channel 8-15)				
byte 6	Wireless slave diagnostic information*1 (Wireless channel 1-7)				
byte 7	Wireless slave diagnostic information (Wireless channel 8-15)				
byte 8	Wireless slave registration information (Wireless channel 1-7; bit 0 are fixed at "0".)				
byte 9	Wireless slave registration information (Wireless channel 8-15)				
byte 10	Wireless master module	DX#D (Unit 1)	Wireless slave module (Wireless channel 002)	DY#B (Unit 3)	
byte 11		Reserved		Reserved	
byte 12		Reserved			
byte 14	Wireless slave module (Wireless channel 001)	DX#D (Unit 1)	/		
byte 15		AXA (Unit 2)			
byte 16					
byte 17					
byte 18					
byte 19		Reserved			
byte 20	Reserved				
byte 22	Wireless slave module (Wireless channel 002)	DX#D (Unit 1)			
byte 23		DX#B (Unit 2)			
byte 24					
byte 25		Reserved			
Total	26 byte			12 byte	

*: When the setting of diagnostic allocation is "Detailed", areas of the number of slaves set at the Number of slave connection are occupied. (The occupied area also occupies the area for wireless slave unit which has not been registered.)

*1: The wireless slave diagnostic information bit 0 indicates the diagnostic information of the master.

■ Diagnostic allocation

By setting the diagnostic allocation of the wireless master unit, the following diagnostic data will be allocated to the head of the input data of the I/O map.

When the diagnostic allocation is set to "Detailed", the diagnostic size varies depending on the number of slave connections.

Diagnostic allocation	Diagnostic data	Diagnostic size
None	No diagnostic data	0 bytes
Simple	System diagnostics	4 bytes
Details	System diagnostics + Wireless slave connection / diagnostics / registration information	Number of slave connections: 0 pcs.
		Number of slave connections: 15 pcs.
		Number of slave connections: 31 pcs.

• Wireless system configuration

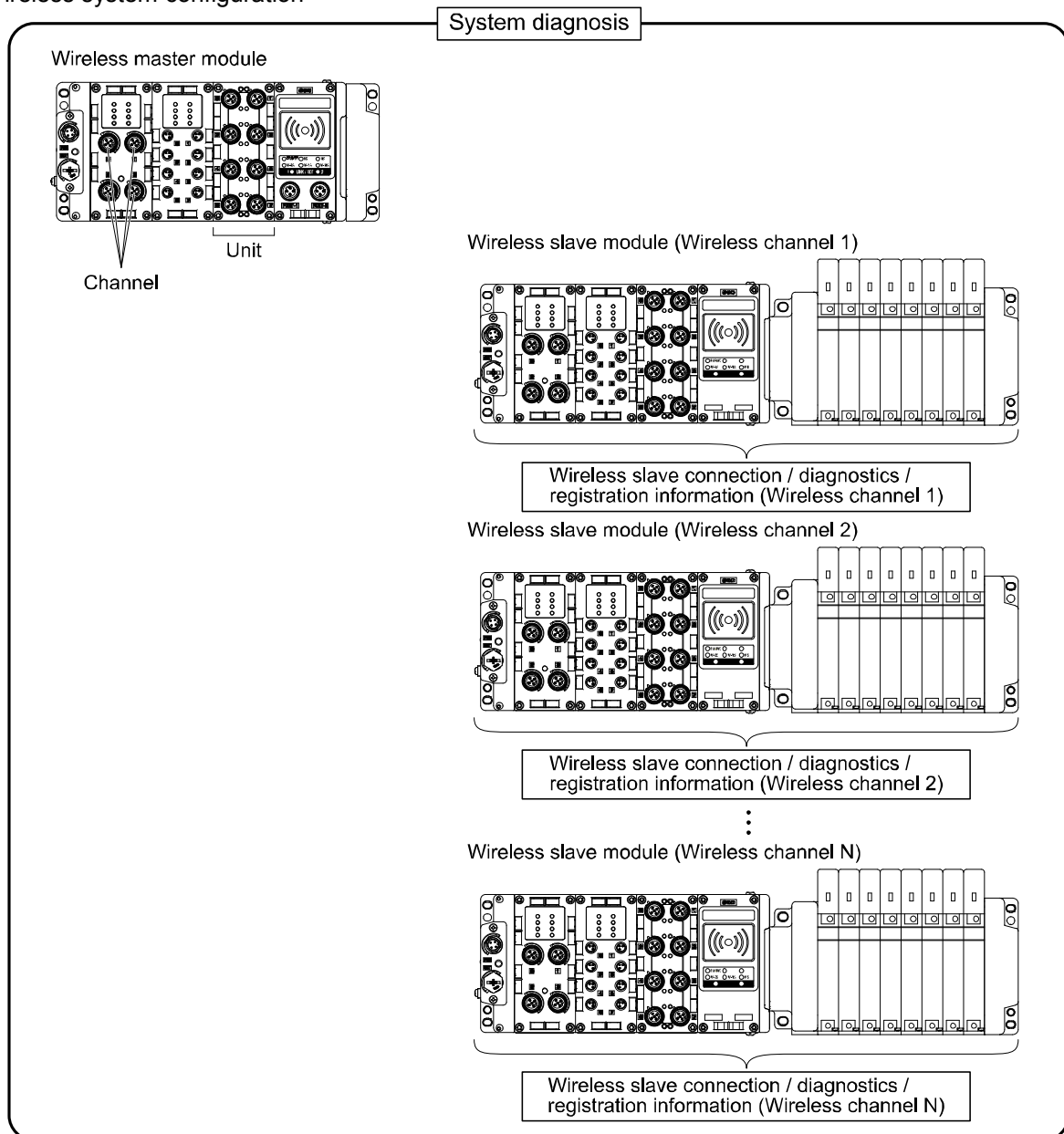

■ Detailed diagnostic data

When an error occurs in the wireless system (wireless master or slave modules), a flag will be generated in a Bit corresponding to each diagnostic information.

The errors for the system diagnostics 1 to 4 are for the entire system. Therefore, even if there is only one unit which has an error in the constructed system, a flag will be generated in a Bit corresponding to the error content.

It is possible to check the classification of the wireless slave module which is generating an error using the wireless slave diagnostic information.

(It is necessary to set the diagnostic allocation to "Detailed".)

Regardless of the setting of the diagnostic allocation, the module and unit which are generating errors can be specified using the SMC wireless system application.

Item	Byte	Bit No.	Content of diagnostics		Diagnosis area and condition when error occurs		How to reset	Reset conditions	Note (LED indications, etc.)
			Item	Details	Effective diagnosis area	I/O condition when diagnosis is conducted			
System diagnosis 1	0	0	User setting lower level detection	Detected that the analogue setting has exceeded the lower limit of the user set value.	Unit	Continue	Automatic reset	Select the range so that the analogue setting will be within the appropriate range of the user set value. Or disable the diagnostics.	Wireless master unit SF: Red LED flashes or W-MS: Red LED flashes *1 Wireless slave unit MS: Red LED flashes
		1	User setting upper limit detection	Detected that the analogue setting has exceeded the upper limit of the user set value.	Unit	Continue	Automatic reset	Select the range so that the analogue setting will be within the appropriate range of the user set value. Or disable the diagnostics.	
		2	Detection of the range lower limit	Detected that the analogue setting has exceeded the lower limit of the setting range.	Unit	Continue	Automatic reset	Select an appropriate range so that the input value is within the set range.	
		3	Detection of the range upper limit	Detected that the analogue setting has exceeded the upper limit of the setting range.	Unit	Continue	Automatic reset	Select an appropriate range so that the input value is within the set range.	
		4	Detection of upper limit of ON/OFF operation cycle	ON/OFF operating cycles has exceeded the upper limit of the setting value.	Unit	Continue	Automatic reset	Reset the ON/OFF cycles to zero. Or disable the diagnostics.	
		5	Detection of unconnected load	Detects the broken wire.	Unit	Continue	Manual/automatic reset	(1) Replace the valve or I/O device to check the operation. (2) Replace the valve or output device to check the operation.	

Item	Byte	Bit No.	Content of diagnostics		Diagnosis area and condition when error occurs		How to reset	Reset conditions	Note (LED indications, etc.)	
			Item	Details	Effective diagnosis area	I/O condition when diagnosis is conducted				
System diagnostic 1	0	6	Short circuit detection of output load	A short-circuit of the valve or the output equipment has been detected.	Unit	Continue	Manual / Auto	(1) Replace the valve or the input/output equipment, and check the operation. (2) Replace the valve or the output equipment, and check the operation.	Wireless master unit SF: Red LED flashes or W-MS: Red LED flashes *1	
		7	Short circuit detection of power supply for control / input	A short-circuit of the input equipment power supply has been detected.	Unit	Continue	Auto	Check the part which has been generating the error and review the wiring or check if the input equipment is normal.	Wireless slave unit MS: Red LED flashes	
System diagnostic 2	1	0	Detection of output (US2) power supply voltage drop	A voltage drop of the power supply voltage for output (US2) has been detected.	Unit	Continue	Auto	Supply 24 VDC±10% to the power supply voltage for output (US2).	Wireless master unit PWR: Green LED Flashes SF: Red LED flashes or W-MS: Red LED flashes Wireless slave unit PWR(V): Red LED flashes	
		1	Detection of control / input (US1) power supply voltage drop	A voltage drop of the power supply voltage for control / input (US1) has been detected.	Unit	Continue	Auto	Supply 24 VDC±10% to the power supply voltage for control / input (US1).	Wireless master unit PWR: Red LED flashes SF: Red LED flashes or W-MS: Red LED flashes Wireless slave unit MS: Red LED flashes	
		2	Reserved	-	-	-	-	-	-	-
		3	Connection failure between units (during operation)	An error has been generated in the communication between the wireless unit and EX600 I/O units.	Unit	Stop (HOLD)	Turn the power on again.	Confirm that there is no loose connection between the EX600 I/O units, and connect them correctly.	Wireless master unit SF: Red LED flashes or W-MS: Red LED flashes Wireless slave unit MS: Red LED flashes	

Item	Byte	Bit No.	Content of diagnostics		Diagnosis area and condition when error occurs		How to reset	Reset conditions	Note (LED indications, etc.)
			Item	Details	Effective diagnosis area	I/O condition when diagnosis is conducted			
System diagnostic 2	1	4	Connection failure between units (when power is supplied)	An error has been generated in the communication between the wireless unit and EX600 I/O units.	Unit	Stop (HOLD)	Turn the power on again.	Confirm that there is no loose connection between the EX600 I/O units, and connect them correctly.	Wireless master unit SF: Red LED flashes or W-MS: Red LED flashes Wireless slave unit MS: Red LED flashes
		5	Reserved	-		-	-	-	-
		6	Detection of system error (when power is supplied)	A non-restorable error has been generated in the system.	Unit	Stop (HOLD)	Manual	Supply power again. If the error is not restored, contact your SMC sales representative.	Wireless master unit SF: Red LED is ON Wireless slave unit MS: Red LED is ON
System diagnostic 3	2	0	Number of input / output points setting error	The number of occupied input / output points of the wireless master and slave units has exceeded the set value.	System	Continue	Manual	Change the user's set value. Or, adjust the unit configuration so that the number of occupied points is within the set value.	Wireless master unit SF: Red LED flashes or W-MS: Red LED flashes Wireless slave unit MS: Red LED flashes
		1	Reserved	-	-	-	-	-	-
		2	Reserved	-	-	-	-	-	-
		3	Reserved	-	-	-	-	-	-
		4	Reserved	-	-	-	-	-	-
		5	Reserved	-	-	-	-	-	-
		6	Reserved	-	-	-	-	-	-
		7	Reserved	-	-	-	-	-	-

Item	Byte	Bit No.	Content of diagnostics		Diagnosis area and condition when error occurs		How to reset	Reset conditions	Note (LED indications, etc.)
			Item	Details	Effective diagnosis area	I/O condition when diagnosis is conducted			
System diagnostic 4	3	0	Reserved	-	-	-	-	-	-
		1	Number of slave connections setting error (Outside of the wireless channel setting range)	Wireless channels other than those set at the Wireless slave connection have been registered.	System	Continue	Manual	Change the number of slave connection set value. Or, delete the registration of the wireless slaves (wireless channels) outside of the set range.	Wireless master unit SF: Red LED flashes
		2	Reserved	-	-	-	-	-	-
		3	Reserved	-	-	-	-	-	-
		4	Reserved	-	-	-	-	-	-
		5	Number of system input / output points has exceeded the upper limit	The number of occupied system input / output points has exceeded 1280 / 1280 points.	System	Stop (HOLD)	Manual	Adjust the unit configuration so that the number of system input / output points is within the controllable numbers.	Wireless master unit SF: Red LED is ON or W-NS: Red LED is ON
		6	Wireless registration data failed	An error has been generated in the wireless registration information.	System	Stop (HOLD)	Manual	Supply power again. If the error is not restored after resupplying power, contact your SMC sales representative.	Wireless master unit SF: Red LED is ON or W-NS: Red LED is ON
		7	Detection of wireless hardware error	A Non-restorable error has been generated in the hardware of the wireless units.	System	Stop (HOLD)	Manual	Supply power again. If the error is not restored after resupplying power, contact your SMC sales representative.	Wireless master unit SF: Red LED is ON or W-NS: Red LED is ON

Item	Byte	Bit No.	Content of diagnostics		Diagnosis area and condition when error occurs		How to reset	Reset conditions	Note (LED indications, etc.)
			Item	Details	Effective diagnosis area	I/O condition when diagnosis is conducted			
Wireless slave connection information Wireless channel 1-7 (Bit 0 is fixed at "0".)	4	0	-	-	-	-	-	When the connection data is "0", the wireless communication with the wireless slave unit is not connected. When the connection data is "1", the wireless communication with the wireless slave unit is normal.	
		1	Connection condition of the wireless slave unit communication (Wireless channel 1)	-	-	-	-		
		2	Connection condition of the wireless slave unit communication (Wireless channel 2)	-	-	-	-		
		3	Connection condition of the wireless slave unit communication (Wireless channel 3)	-	-	-	-		
		4	Connection condition of the wireless slave unit communication (Wireless channel 4)	-	-	-	-		
		5	Connection condition of the wireless slave unit communication (Wireless channel 5)	-	-	-	-		
		6	Connection condition of the wireless slave unit communication (Wireless channel 6)	-	-	-	-		
		7	Connection condition of the wireless slave unit communication (Wireless channel 7)	-	-	-	-		
Wireless slave connection information Wireless channel 8-15	5	0	Connection condition of the wireless slave unit communication (Wireless channel 8)	-	-	-	-		
		1	Connection condition of the wireless slave unit communication (Wireless channel 9)	-	-	-	-		
		2	Connection condition of the wireless slave unit communication (Wireless channel 10)	-	-	-	-		
		3	Connection condition of the wireless slave unit communication (Wireless channel 11)	-	-	-	-		
		4	Connecting condition of the wireless slave unit communication (Wireless channel 12)	-	-	-	-		
		5	Connection condition of the wireless slave unit communication (Wireless channel 13)	-	-	-	-		
		6	Connection condition of the wireless slave unit communication (Wireless channel 14)	-	-	-	-		
		7	Connection condition of the wireless slave unit communication (Wireless channel 15)	-	-	-	-		

Item	Byte	Bit No.	Content of diagnostics		Diagnosis area and condition when error occurs		How to reset	Reset conditions	Note (LED indications, etc.)
			Item	Details	Effective diagnosis area	I/O condition when diagnosis is conducted			
Wireless slave diagnostic information Wireless channel 1-7 (Bit 0 is for the wireless master module)	6	0	Presence / absence of system information error of wireless master module		-	-	-	-	No error in the wireless master / slave module when the diagnostic data is "0".
		1	Presence / absence of system information error of wireless slave module (Wireless channel 1)		-	-	-	-	
		2	Presence / absence of system information error of wireless slave module (Wireless channel 2)		-	-	-	-	
		3	Presence / absence of system information error of wireless slave module (Wireless channel 3)		-	-	-	-	
		4	Presence / absence of system information error of wireless slave module (Wireless channel 4)		-	-	-	-	
		5	Presence / absence of system information error of wireless slave module (Wireless channel 5)		-	-	-	-	
		6	Presence / absence of system information error of wireless slave module (Wireless channel 6)		-	-	-	-	
		7	Presence / absence of system information error of wireless slave module (Wireless channel 7)		-	-	-	-	
Wireless slave diagnostic information (Wireless channel 8-15)	7	0	Presence / absence of system information error of wireless slave module (Wireless channel 8)		-	-	-	-	An error has been generated in the wireless master / slave module when the diagnostic data is "1".
		1	Presence / absence of system information error of wireless slave module (Wireless channel 9)		-	-	-	-	
		2	Presence / absence of system information error of wireless slave module (Wireless channel 10)		-	-	-	-	
		3	Presence / absence of system information error of wireless slave module (Wireless channel 11)		-	-	-	-	
		4	Presence / absence of system information error of wireless slave module (Wireless channel 12)		-	-	-	-	
		5	Presence / absence of system information error of wireless slave module (Wireless channel 13)		-	-	-	-	
		6	Presence / absence of system information error of wireless slave module (Wireless channel 14)		-	-	-	-	
		7	Presence / absence of system information error of wireless slave module (Wireless channel 15)		-	-	-	-	

Item	Byte	Bit No.	Content of diagnostics		Diagnosis area and condition when error occurs		How to reset	Reset conditions	Note (LED indications, etc.)
			Item	Details	Effective diagnosis area	I/O condition when diagnosis is conducted			
Wireless slave registration information Wireless channel 1-7 (Bit 0 is fixed at "0".)	8	0	-	-	-	-	-	When the registration data is "0", no wireless slave unit has been registered. When the registration data is "1", wireless slave units have been registered.	
		1	Registration of wireless slave unit (Wireless channel 1)	-	-	-	-		
		2	Registration of wireless slave unit (Wireless channel 2)	-	-	-	-		
		3	Registration of wireless slave unit (Wireless channel 3)	-	-	-	-		
		4	Registration of wireless slave unit (Wireless channel 4)	-	-	-	-		
		5	Registration of wireless slave unit (Wireless channel 5)	-	-	-	-		
		6	Registration of wireless slave unit (Wireless channel 6)	-	-	-	-		
		7	Registration of wireless slave unit (Wireless channel 7)	-	-	-	-		
Wireless slave registration information (Wireless channel 8-15)	9	0	Registration of wireless slave unit (Wireless channel 8)	-	-	-	-		
		1	Registration of wireless slave unit (Wireless channel 9)	-	-	-	-		
		2	Registration of wireless slave unit (Wireless channel 10)	-	-	-	-		
		3	Registration of wireless slave unit (Wireless channel 11)	-	-	-	-		
		4	Registration of wireless slave unit (Wireless channel 12)	-	-	-	-		
		5	Registration of wireless slave unit (Wireless channel 13)	-	-	-	-		
		6	Registration of wireless slave unit (Wireless channel 14)	-	-	-	-		
		7	Registration of wireless slave unit (Wireless channel 15)	-	-	-	-		

*: The LED indicator W-MS on the wireless master unit indicates the system status of the wireless slave module.

If it is ON or flashes, errors have been generated in the registered wireless slave module.

*: When the diagnostic data of the system diagnostics 1-4 is "0", no error is generated. When it is "1", errors have been generated.

*: This table is for 15 connected wireless slaves as set in the master unit setting.

The diagnostic size of the wireless slave connection information, diagnostic information and registration information vary depending on the setting for the number of connected wireless slaves. Refer to the diagnostic size shown in the section "Diagnostic allocation" for details.

- Channel diagnostic data
Online diagnostic method utilizing Siemens STEP7 is detailed below.
(1) On the **HW Config** screen, click the button below to switch from OFFLINE to ONLINE.

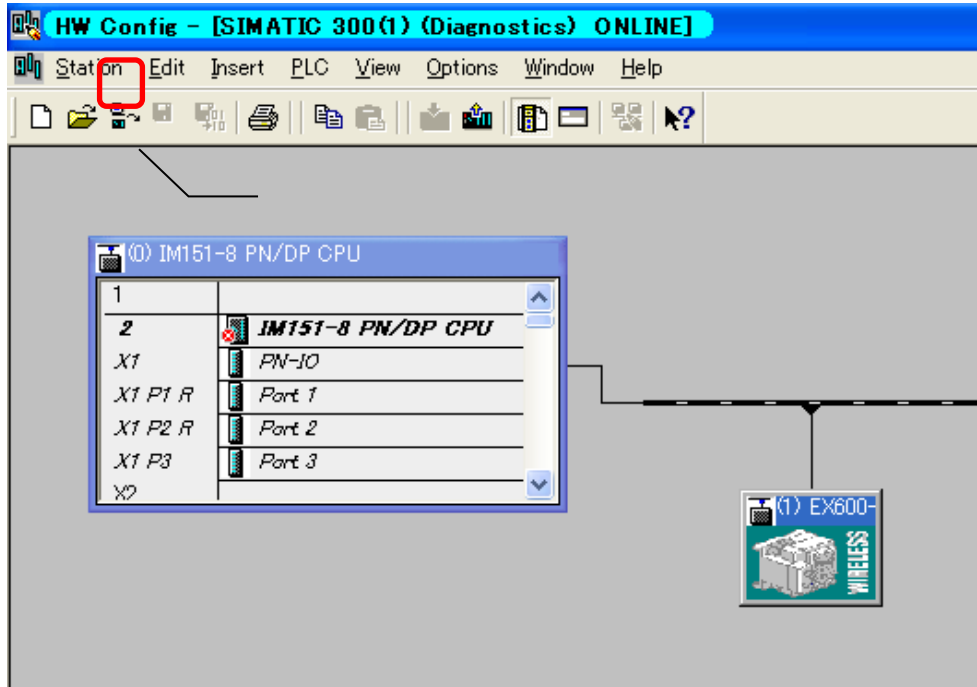

- (2) Double click the **Diagnosis module (Slot 1)** in the **Configuration table** window.
- (3) The **Module Information** window will be displayed, click on the **IO Device Diagnostics** tab. The presence of any diagnostics can be checked per wireless master unit and wireless slave channel. Diagnostic details can be checked with the input data system diagnostics, as well as the SMC wireless system settings application.

The screenshot shows the SIMATIC Manager HW Config interface. The main window displays a configuration table for a SIMATIC 300(1) system. The table lists modules for slot 1, including a diagnosis module. The 'Module Information - Diagnosis 015' window is open, showing the 'IO Device Diagnostics' tab. The status is 'Error'. The 'Channel-specific diagnostics' table shows an error for slot 1, channel 0: 'Master One error or some errors'.

Slot	Channel no.	Error
1	0	Master One error or some errors

Specifications

•Wireless master unit specifications

Models		EX600-WPN1	EX600-WPN2	
Communication specifications	Communication protocol		PROFINET IO	
	Conformance class		Class C (only for IRT switch function)	
	Transmission medium (cable)		Standard Ethernet cable (CAT5 or higher, 100BASE-TX)	
	Transmission speed		100 Mbps	
	FSU(Fast start up)		Applicable	
	MRP(Media Redunancy Protocol)		Applicable	
Electrical specifications	For control and input (US1)	Power supply voltage	24 VDC \pm 10%	
		Current consumption	150 mA or less	
	For output (US2)	Power supply voltage	24 VDC \pm 10%	
		Max. supply current	4 A	
Input/Output specifications	Number of inputs	System input size	Max. 1280 points together with the registered slave units	
		Input size	Max. 128 points (increase or decrease by 16 points)	
	Number of outputs	System output size	Max. 1280 points together with the registered slave units	
		Output size	Max. 128 points (increase or decrease by 16 points)	
	Valve output	Output type	Source / PNP (-COM)	Sink / NPN (+COM)
		Number of outputs	Max. 32 points (0 / 8 / 16 / 24 / 32 points)	
		Connected load	Solenoid valve with surge voltage suppressor of 24 VDC and 1.5W or less (manufactured by SMC)	
		Output condition at the time of communication error	Clear / Hold / Software control	
		Protection	Built-in short circuit prevention	
	Number of slave units connected		Max. 31 pcs. (0 / 15 / 31 pcs.)	
	Number of connected EX600 I/O units		Max. nine EX600 I/O units (I/O = 128. I/O above 128 cannot be recognized)	
Wireless communication specifications	Protocol		SMC original protocol (SMC encryption)	
	Radio wave type (spread)		Frequency Hopping Spread Spectrum (FHSS)	
	Frequency		2.4 GHz (2403 to 2481 MHz)	
	Frequency channel		79 ch (Bandwidth: 1.0 MHz)	
	Communication speed		250 kbps	
	Communication distance		Within 10 m (depending on the operating environment)	
	Radio Law certificate		Japanese radio law, RE, FCC	

Models		EX600-WPN1	EX600-WPN2
NFC communication specifications *	Communication standard	ISO/IEC14443B (Type-B)	
	Frequency	13.56 MHz	
	Communication speed	20 to 100 kHz (I2C)	
	Communication distance	Up to 1 cm	
Environmental resistance	Enclosure rating	Conforms to IP67 (with manifold assembled)	
	Ambient operating temperature	-10 to +50°C	
	Ambient storage temperature	-20 to +60°C	
	Ambient humidity	35 to 85% RH (no condensation)	
	Withstand voltage	500 VAC-1 minute between external terminals and metallic parts	
	Insulation resistance	10 MΩ or more (500 VDC between external terminals and metallic parts)	
	Vibration resistance	Conforms to EN61131-2 5 ≤ f < 8.4 Hz 3.5 mm 8.4 ≤ f < 150 Hz 9.8 m/s ²	
Impact resistance	Conforms to EN61131-2 147 m/s ² , 11 ms		
Standard	CE, FCC		
Weight	300 g		

*: The NFC communication RFID tag of the 13.56 MHz passive type.

•Wireless slave unit specifications

Models			EX600-WSV1	EX600-WSV2	
Electrical specifications	For control and input (US1)	Power supply voltage	24 VDC \pm 10%		
		Current consumption	70 mA or less		
	For output (US2)	Power supply voltage	24 VDC \pm 10%		
		Max. supply current	4 A		
Input/output specifications	Number of inputs	Input size	Max. 128 points (increase or decrease by 16 points)		
	Number of outputs	Output size	Max. 128 points (increase or decrease by 16 points)		
	Valve output	Output type	Source / PNP (-COM)	Sink / NPN (+COM)	
		Number of outputs	Max. 32 points (0 / 8 / 16 / 24 / 32 points)		
		Connected load	Solenoid valve with surge voltage suppressor of 24 VDC and 1.5 W or less (manufactured by SMC)		
		Output condition at the time of communication error	Clear / Hold / Software control		
		Protection	Built-in short circuit prevention		
	Number of connected EX600 I/O units		Max. Nine EX600 I/O units (I/O = 128, I/O above 128 cannot be recognized)		
Wireless communication specifications	Protocol		SMC original protocol (SMC encryption)		
	Radio wave type (spread)		Frequency Hopping Spread Spectrum (FHSS)		
	Frequency		2.4 GHz (2403 to 2481 MHz)		
	Frequency channel		79 ch (Bandwidth: 1.0 MHz)		
	Communication speed		250 kbps		
	Communication distance		Within 10 m (depending on the operating environment)		
	Radio Law certificate		Japanese radio law, RE, FCC		
NFC communication specifications *	Communication standard		ISO/IEC144437B (Type-B)		
	Frequency		13.56 MHz		
	Communication speed		20 to 100 kHz (I2C)		
	Communication distance		Up to 1 cm		
Environmental resistance	Enclosure rating		Conforms to IP67 (with manifold assembled)		
	Ambient Operating temperature		-10 to +50 °C		
	Ambient Storage temperature		-20 to +60 °C		
	Ambient humidity		35 to 85%RH (no condensation)		
	Withstand voltage		500 VAC-1 minute between external terminals and metallic parts		
	Insulation resistance		10 M Ω or more (500 VDC between external terminals and metallic parts)		
	Vibration resistance		Conforms to EN61131-2 5 \leq f < 8.4 Hz 3.5 mm 8.4 \leq f < 150 Hz 9.8 m/s ²		
Impact resistance		Conforms to EN61131-2 147 m/s ² , 11 ms			
Standard			CE, FCC		
Weight			280 g		

*: The NFC communication RFID tag of the 13.56 MHz passive type.

Troubleshooting

When problems occur, take appropriate countermeasures while referring to the LED indication, troubleshooting and parameter settings.

If a cause applicable to the failure cannot be identified, this indicates that the equipment itself is broken. The fieldbus system damage can be caused by the operating environment. Contact SMC to obtain countermeasures.

•Troubleshooting list for wireless master unit

LED	Description	Error indication	No.
-	All LEDs are OFF.	-	Refer to problem No. 1.
PWR	PWR LED does not turn on green.	Green LED flashes.	Refer to problem No. 2.
		Red LED flashes.	
		OFF	
SF	SF LED is not OFF.	Green LED flashes.	Refer to problem No. 3.
		Red LED flashes.	
		Red LED is ON.	
BF	SF LED is not OFF.	Red LED flashes.	Refer to problem No. 4.
		Red LED is ON.	
W-SS	Red W-SS LED flashes or is OFF.	Red LED flashes.	Refer to problem No. 5.
		OFF	
W-NS	W-NS LED does not turn on green.	Green LED flashes.	Refer to problem No. 6.
		Red LED flashes.	
		Red LED is ON.	
		Orange LED is ON.	
		Red and green LEDs are ON alternately.	
W-MS	W-MS LED does not turn on green.	OFF	Refer to problem No. 7.
		Red LED flashes.	
		Red LED is ON.	
LINK / ACT	LINK / ACT1 and 2 LED are ON or OFF.	OFF	Refer to problem No. 8.
		ON	
The valve does not operate correctly.			Refer to problem No. 9.
Digital input /output device does not operate correctly.			Refer to problem No. 10.
Analogue input /output device does not operate correctly			Refer to problem No. 11.
Problems related to NFC.			Refer to problem No. 12.

•Troubleshooting for wireless master unit

Problem No.	Error indication	Possible cause	Investigation and countermeasures
1	All LEDs are OFF.	Power supply for control and input (US1) has not been supplied.	Supply a voltage of 24 VDC±10% to the power supply for control and input (US1).
2	PWR: Green LED is ON	Output power supply voltage (US2) is low.	The power supply voltage for output (US2) has dropped. Check that a voltage of 24 VDC±10% is applied.
	PWR: Red LED flashes.	Control and input power supply voltage (US1) is low.	The power supply voltage for control and input (US1) has dropped. Check that a voltage of 24 VDC±10% is applied.
	PWR: LED is OFF.	Power supply for control and input (US1) has not been supplied.	Supply a voltage of 24 VDC±10% to the power supply for control and input (US1).
3	SF: Red LED flashes.	<p>The following diagnostic information is detected.</p> <p>(1) Low power supply voltage for control and input (US1).</p> <p>(2) Low power supply voltage for output (US2).</p> <p>(3) Excessive I/O setting inputs/outputs.</p> <p>(4) Abnormal number of slave connection</p> <p>(5) Error in communication between units. (4)-1 Abnormal digital input unit. (4)-2 Abnormal digital output unit. (4)-3 Abnormal digital input / output unit.</p> <p>(6) EX600 I/O unit detects diagnostic information. (6)-1 Short-circuited power supply voltage for control and input (US1). (6)-2 Short-circuited power supply voltage for output (US2). (6)-3 Short-circuited output load (6)-4 Analogue I/O upper and lower set limit exceeded (6)-5 Analogue Input range upper and lower limit exceeded</p> <p>(7) Valve diagnostic information detected. (7)-1 Valve short-circuited.</p>	<p>After checking the error contents referring to the system diagnostic information and LED indication, refer to the following countermeasures.</p> <p>(1) The power supply voltage for control and input (US1) has dropped. Check that a voltage of 24 VDC±10% is applied.</p> <p>(2) The power supply voltage for output (US2) has dropped. Check that a voltage of 24 VDC±10% is applied.</p> <p>(3)-1 The number of system input / output points has exceeded the set value. Check the total number of input / output points allocated to the wireless system (master unit and slave unit). (3)-2 The input and output sizes have exceeded the set value. Check the occupied bytes of the EX600 I/O unit and valve manifold connected to the wireless master unit.</p> <p>(4) Change the set number of slave connections. Delete the registration of the wireless slaves (wireless channels) outside of the set range or change the channel setting.</p> <p>(5) Confirm that there is no loose connection between the units and connect them correctly.</p> <p>(6) Check the part where the error occurs by checking the LED indication and information of the system diagnostics, and refer to the operation manual for the digital and analogue unit.</p> <p>(7) Replace the valve and check the operation.</p>

Problem No.	Error indication	Possible cause	Investigation and countermeasures
3	SF: Red LED is ON	Wireless master unit broken	Replace the wireless master unit. If the error is not restored after replacement, stop using the equipment and contact your SMC sales representative.
4	SF: Red LED flashes.	Configuration data does not match.	Check PLC configuration settings and match them with the actual configurations.
	SF: Red LED is ON	Abnormality in communication with PLC	Check the following: (1) PLC power supply is ON. (2) Check if the connector is loose or if the wire is broken. (3) Check that the PLC and SI unit are not faulty. (4) Check that the PLC settings match with the Device name of the SI unit.
5	W-SS: Red LED flashes.	(1) Power has not been supplied to the wireless slave unit. (2) Low signal power on wireless communication.	(1) Check that the power supply voltage for control and input (US1) is supplied to the wireless slave unit. (2) The distance which wireless communication between wireless systems can be established may have been exceeded. Reconsider the operating environment, such as the installation conditions, of the wireless master and wireless slave.
	W-SS: LED is OFF.	Wireless slave unit has not been registered.	Check the registration status of the wireless slave unit and conduct pairing correctly.

Problem No.	Error indication	Possible cause	Investigation and countermeasures
6	W-NS: Green LED flashes.	(1) Power to the wireless slave unit is OFF. (2) Low signal power on wireless communication.	(1) Check that the power supply voltage for control and input (US1) is supplied to the wireless slave unit. (2) The distance which wireless communication between wireless systems can be established may have been exceeded. Reconsider the operating environment, such as the installation conditions, of the wireless master and wireless slave.
	W-NS: Red LED flashes.	(1) Power to the wireless slave unit is OFF. (2) Low signal power on wireless communication.	(1) Check that the power supply voltage for control and input (US1) is supplied to the wireless slave unit. (2) The distance which wireless communication between wireless systems can be established may have been exceeded. Reconsider the operating environment, such as the installation conditions, of the wireless master and wireless slave.
	W-NS: Red LED is ON.	No wireless slave units are connected.	Replace the wireless master unit. If the error is not restored after replacement, stop using the equipment and contact your SMC sales representative.
	W-NS: Orange LED is ON.	Forced output.	The wireless master unit has been set to Forced output mode. Change the mode according to the application.
	W-NS: Red/green	Wireless communication connection is in pairing mode.	The system has been set to "Pairing enable". Change the setting to "Pairing disable" when pairing is not conducted.
	W-NS: LED is OFF.	Wireless slave unit has not been registered.	Check the registration status of the wireless unit and conduct pairing correctly.

Problem No.	Error indication	Possible cause	Investigation and countermeasures
7	W-MS: Red LED flashes.	<p>The following diagnostic information is detected.</p> <p>(1) Low power supply voltage for control and input (US1).</p> <p>(2) Low power supply voltage level for output (US2).</p> <p>(3) Excessive I/O setting for inputs/outputs.</p> <p>(4) Error in communication between units. (4)-1 Abnormal digital input unit. (4)-2 Abnormal digital output unit. (4)-3 Abnormal digital input / output unit.</p> <p>(5) EX600 I/O unit detects diagnostic information. (5)-1 Short-circuited power supply voltage for control and input (US1). (5)-2 Short-circuited power supply voltage for output (US2). (5)-3 Short-circuited output load. (5)-4 Analogue I/O upper and lower set limit exceeded (5)-5 Analogue Input range upper and lower limit exceeded</p> <p>(6) Valve diagnostic information detected. (6)-1 Valve short-circuited.</p>	<p>After checking the error contents while referring to the system diagnostic information and LED indication, refer to the following countermeasures.</p> <p>As this LED indicates the system status of the wireless slave unit, the following diagnoses can be conducted only when the diagnostic allocation is set to "Detailed".</p> <p>(1) The power supply voltage for control and input (US1) has dropped. Check that a voltage of 24 VDC±10% is supplied.</p> <p>(2) The power supply voltage for output (US2) has dropped. Check that a voltage of 24 VDC±10% is supplied.</p> <p>(3) The input and output sizes have exceeded the set value. Check the occupied bytes of the EX600 I/O unit and valve manifold connected to the wireless slave module.</p> <p>(4) Confirm that there is no loose connection between the units and connect them correctly.</p> <p>(5) Check the part where the error occurs by checking the LED indication and information of the system diagnosis, and refer to the operation manual for the digital and analogue unit.</p> <p>(6) Replace the valve, and check the operation.</p>
	W-MS: Red LED is ON.	Wireless slave unit broken.	<p>Replace the wireless slave unit.</p> <p>If the error is not restored after replacement, stop using the equipment and contact your SMC sales representative.</p>
	W-MS: LED is OFF.	<p>(1) Wireless slave unit has not been registered.</p> <p>(2) Power has not been supplied to the wireless slave unit.</p>	<p>(1) Check the registration status of the wireless slave unit and conduct pairing correctly.</p> <p>(2) Check that the power supply voltage for control and input (US1) is supplied to the wireless slave unit.</p>

Problem No.	Error indication	Possible cause	Investigation and countermeasures
8	LINK/ACT: LED is ON. (PORT-1, -2)	LINK is established, but no data has been received.	Check the following items and restart. (1) Check the PLC condition and run the PLC. (2) Check for looseness and broken lines of the connector. (3) Keep noise sources away from the communication cable.
	LINK/ACT: LED is OFF. (PORT-1, -2)	LINK has not been established.	Check the following items and restart. (1) Check that power is supplied to the PROFINET device one level above. (2) Check for looseness and broken lines of the connector of the LINK/ACT PORT 1 / PORT 2 communication cables. (3) Keep noise sources away from the communication cable.
9	Abnormal valve operation.	Abnormal program.	Check if the program such as PLC ladder logic program works correctly.
		Output power supply voltage (US2) is low.	Check that the green PWR(V) LED of the wireless master unit is ON. If it is OFF or a red LED flashes, supply a voltage of 24 VDC±10% to the power supply for output (US2).
		Connection failure between the wireless master unit and valve manifold.	Confirm that the connector between the wireless master unit and valve manifold has not been damaged, such as bent pins, and connect them correctly.
		Mismatched output type.	If the polarity of the valve does not match with the wireless master unit, replace one of them to make the combination match. •EX600-WPN1 (PNP output) ⇒ Negative common type valve (-COM) •EX600-WPN2 (NPN output) ⇒ Positive common type valve (+COM)
		Wireless master unit broken.	Replace the wireless master unit and check the operation.
		Valve failure.	Replace the valve, and check the operation. Or refer to Troubleshooting for the valve.

Problem No.	Error indication	Possible cause	Investigation and countermeasures
10	Abnormal digital input device operation.	Mismatched input type.	If the polarities (PNP, NPN) of the digital input unit do not match with those of digital input equipment, replace one of them to make the combination match.
		Low power supply voltage for control and input (US1).	Check that the power supply voltage for control and input (US1) of 24 VDC±10% is supplied to the wireless master unit.
		Wiring or connection failure.	Connect the wiring between the digital input unit and the digital input equipment correctly.
		Digital input unit broken.	Replace the digital input unit, and check the operation.
		Digital input equipment broken.	Replace the digital input equipment, and check the operation. Or, refer to Troubleshooting for the applicable digital input equipment.
	Abnormal digital output equipment operation.	Mismatched output type.	If the polarities (PNP, NPN) of the digital output unit do not match with those of digital output equipment, replace one of them to make the combination match.
		Output power supply voltage (US2) is low.	Check that the green PWR(V) LED of the wireless master unit is ON. If it is OFF or a red LED flashes, supply a voltage of 24 VDC±10% to the power supply for output (US2).
		Wiring or connection failure.	Connect the wiring between the digital output unit and the digital output equipment correctly.
		Digital output unit broken.	Replace the digital output unit, and check the operation.
		Digital output equipment broken.	Replace the digital output equipment, and check the operation. Or, refer to Troubleshooting for the applicable digital output equipment.
		Abnormal program.	Check that the program such as PLC ladder logic program operates correctly.

Problem No.	Error indication	Possible cause	Investigation and countermeasures
11	Abnormal operation of the analogue input equipment	Abnormal power supply for control and input (US1)	Check that the power supply voltage for control and input (US1) supplied to the wireless master unit is 24 VDC \pm 10%.
		Analogue input signal range setting failure	Check the analogue input equipment specification, and set the input signal range according to the specification.
		Analogue data format does not match.	Check that the data format setting of the analogue input unit is correct.
		Wiring or connection is defective.	Connect the wiring between the digital input unit and the digital input equipment correctly.
		Analogue input unit faulty	Replace the analogue input unit, and check the operation.
		Analogue input equipment faulty	Replace the analogue input equipment, and check the operation. Or, refer to Troubleshooting for the applicable analogue input equipment.
	Abnormal operation of the analogue output equipment	Abnormal power supply for output (US2)	Check that the green PWR LED of the wireless master unit is ON. If it is OFF or a red LED flashes, supply a voltage of 24 VDC \pm 10% to the power supply for output (US2).
		Analogue output signal range setting failure	Check the analogue output equipment specification, and set the output signal range according to the specification.
		Analogue data format does not match.	Check that the data format setting of the analogue output unit is correct.
		Wiring or connection is defective.	Connect the wiring between the analogue output unit and the analogue output equipment correctly.
		Analogue output unit faulty	Replace the analogue output unit, and check the operation.
		Analogue output equipment faulty	Replace the analogue output equipment, and check the operation. Or, refer to Troubleshooting for the applicable analogue output equipment.
		Abnormal program, etc.	Check that the ladder logic program works correctly.

Problem No.	Error indication	Possible cause	Investigation and countermeasures
12	NFC communication error	NFC communication is not established (communication failure).	<p>Check the following items and check the operation again.</p> <ul style="list-style-type: none"> •Check if the specifications of the NFC reader / writer to be used are appropriate. •Confirm that the settings of the NFC port and PaSoRi of the PC are correct. •Confirm that the NFC reader / writer are connected correctly. •The communication distance is outside of the NFC range. Place the body (area close to NFC antenna) close to the NFC reader / writer.
		NFC reader/writer broken.	<p>Replace the NFC reader / writer and check the operation. If the error is not restored after replacement, stop using the equipment and contact your SMC sales representative.</p>

•Troubleshooting list for wireless slave module

LED	Details	Error indication	No.
-	All LEDs are OFF.	-	Refer to problem No. 1.
PWR (V)	PWR(V) LED does not turn on green.	Red LED flashes.	Refer to problem No. 2.
MS	MS LED does not turn on green.	Red LED flashes.	Refer to problem No. 3.
		Red LED is ON	
		OFF	
W-SS	Red W-SS LED flashes or is OFF.	Red LED flashes.	Refer to problem No. 4.
		OFF	
W-NS	W-NS LED does not turn on green.	Green LED flashes.	Refer to problem No. 5.
		Red LED flashes.	
		Red LED is ON.	
		Orange LED is ON.	
		Red and green LEDs are ON alternately.	
		OFF	
The valve does not operate correctly.			Refer to problem No. 6.
Digital input /output device does not operate correctly.			Refer to problem No. 7.
Analog input /output device does not operate correctly.			Refer to problem No. 8.
Problems related to the NFC.			Refer to problem No. 9.

•Troubleshooting for wireless slave unit

Problem No.	Error indication	Possible cause	Investigation and countermeasures
1	All LEDs are OFF.	Power supply for control and input (US1) is OFF.	Supply a voltage of 24 VDC \pm 10% to the power supply for control and input (US1).
2	PWR(V): Red LED flashes.	Output power supply voltage (US2) is low.	The power supply voltage for output (US2) has dropped. Check that a voltage of 24 VDC \pm 10% is supplied.
	PWR(V): LED is OFF.	Power supply for control and input (US1) is OFF.	Supply a voltage of 24 VDC \pm 10% to the power supply for control and input (US1).
3	MS: Red LED flashes.	The following diagnostic information is detected.	After checking the error contents while referring to the system diagnostic information and LED indication, refer to the following countermeasures.
		(1) Low power supply voltage level for control and input (US1). (2) Excessive I/O setting inputs/outputs. (3) Error in communication between units. (3)-1 Abnormal digital input unit. (3)-2 Abnormal digital output unit. (3)-3 Abnormal digital input / output unit. (4) EX600 I/O unit detects diagnostic information (4)-1 Short-circuited power supply voltage for control and input (US1). (4)-2 Short-circuited power supply voltage for output (US2). (4)-3 Short-circuited output load. (4)-4 Analogue I/O upper and lower set limit exceeded (4)-5 Analogue Input range upper and lower limit exceeded (5) Valve diagnostic information detected. (5)-1 Valve short-circuited.	(1) The power supply voltage for control and input (US1) has dropped. Check the voltage of 24 VDC \pm 10% is supplied. (2) The input and output sizes have exceeded the set value. Check the occupied bytes of the EX600 I/O unit and valve manifold connected to the wireless slave module. (3) Confirm that there is no loose connection between the units and connect them correctly. (4) Check the part where the error occurs by checking the LED indication and the system diagnostic information, and refer to the operation manual for the digital and analogue unit. (5) Replace the valve, and check the operation.
	MS: Red LED is ON.	Wireless slave unit broken	Replace the wireless slave unit. If the error is not restored after replacement, stop using the equipment and contact your SMC sales representative.
	MS: LED is OFF.	(1) Wireless slave unit has not been registered. (2) Power to the wireless slave unit is OFF.	(1) Check the registration status of the wireless slave unit and conduct pairing correctly. (2) Check that the power supply voltage for control and input (US1) is supplied to the wireless slave unit.

Problem No.	Error indication	Possible cause	Investigation and countermeasures
4	W-SS: Red LED flashes.	(1) Power to the wireless slave unit is OFF. (2) Low signal power on wireless communication.	(1) Check that the power supply voltage for control and input (US1) is supplied to the wireless slave unit. (2) The distance which wireless communication between wireless systems can be established may have been exceeded. Reconsider the operating environment, such as the installation conditions, of the wireless master and wireless slave.
	W-SS: LED is OFF.	Wireless slave unit has not been registered.	Check the registration status of the wireless slave unit and conduct pairing correctly.
5	W-NS: Red LED flashes.	(1) Power to the wireless master unit is OFF. (2) Low signal power on wireless communication.	(1) Check that the power supply voltage for control and input (US1) is supplied to the wireless master unit. (2) The distance which wireless communication between wireless systems can be established may have been exceeded. Reconsider the operating environment, such as the installation conditions, of the wireless master and wireless slave.
	W-NS: Red LED is ON.	No wireless slave units are connected.	Replace the wireless slave unit. If the error is not restored after replacement, stop using the equipment and contact your SMC sales representative.
	W-NS: Orange LED is ON.	Forced output	The wireless master unit has been set to Forced output mode. Change the mode according to the application.
	W-NS: Red/green LED	Wireless communication connection is in pairing mode.	The system has been set to "Pairing enable". Change the setting to "Pairing disable" when pairing is not conducted.
	W-NS: LED is OFF.	Wireless slave unit has not been registered.	Check the registration status of the wireless unit and conduct pairing with the wireless slave unit correctly.

Problem No.	Error indication	Possible cause	Investigation and countermeasures
6	Abnormal valve operation	Abnormal program	Check that the program such as the PLC ladder logic program operates correctly.
		Output power supply voltage (US2) is low.	Check that the green PWR(V) LED of the wireless master unit is ON. If it is OFF or a red LED flashes, supply a voltage of 24 VDC±10% to the power supply for output (US2).
		Connection failure between the wireless master unit and valve manifold.	Confirm that the connector between the wireless master unit and manifold valve has not been damaged, such as bent pins, and connect them correctly.
		Mismatched output type	If the polarity of the valve does not match with the wireless master unit, replace one of them to make the combination match. •EX600-WSV1 (PNP output) ⇒ Negative common type valve (-COM) •EX600-WSV2 (NPN output) ⇒ Positive common type valve (+COM)
		Wireless master unit broken	Replace the wireless master unit and check the operation.
		Valve failure	Replace the valve, and check the operation. Or, refer to Troubleshooting for the valve.

Problem No.	Error indication	Possible cause	Investigation and countermeasures
7	Abnormal digital input device operation	Input type does not match.	If the polarities (PNP, NPN) of the digital input unit do not match with those of digital input equipment, replace one of them to make the combination match.
		Low power supply voltage for control and input (US1)	Check that the power supply voltage for control and input (US1) of 24 VDC \pm 10% is supplied to the wireless master unit.
		Wiring or connection is defective.	Connect the wiring between the digital input unit and the digital input equipment correctly.
		Digital input unit broken	Replace the digital input unit, and check the operation.
		Digital input equipment broken	Replace the digital input equipment, and check the operation. Or, refer to Troubleshooting for the applicable digital input equipment.
	Abnormal digital output equipment operation	Mismatched output type	If the polarities (PNP, NPN) of the digital output unit do not match with those of digital output equipment, replace one of them to make the combination match.
		Output power supply voltage (US2) is low.	Check that the green PWR(V) LED of the wireless master unit is ON. If it is OFF or a red LED flashes, supply a voltage of 24 VDC \pm 10% to the power supply for output (US2).
		Wiring or connection is defective.	Connect the wiring between the digital output unit and the digital output equipment correctly.
		Digital output unit broken	Replace the digital output unit, and check the operation.
		Digital output equipment broken	Replace the digital output equipment, and check the operation. Or, refer to Troubleshooting for the applicable digital output equipment.
		Abnormal program	Check that the program such as the PLC ladder logic program operates correctly.

Problem No.	Error indication	Possible cause	Investigation and countermeasures
8	Abnormal operation of the analogue input equipment	Abnormal power supply for control and input (US1)	Check that the power supply voltage for control and input (US1) supplied to the wireless master unit is 24 VDC \pm 10%.
		Analogue input signal range setting failure	Check the analogue input equipment specification, and set the input signal range according to the specification.
		Analogue data format does not match.	Check that the data format setting of the analogue input unit is correct.
		Wiring or connection is defective.	Connect the wiring between the digital input unit and the digital input equipment correctly.
		Analogue input unit faulty	Replace the analog input unit, and check the operation.
		Analogue input equipment faulty	Replace the analogue input equipment, and check the operation. Or, refer to Troubleshooting for the applicable analogue input equipment.
	Abnormal operation of the analogue output equipment	Abnormal power supply for output (US2)	Check that the green PWR(V) LED of the wireless master unit is ON. If it is OFF or a red LED flashes, supply a voltage of 24 VDC \pm 10% to the power supply for output (US2).
		Analogue output signal range setting failure	Check the analogue output equipment specification, and set the output signal range according to the specification.
		Analogue data format does not match.	Check that the data format setting of the analogue output unit is correct.
		Wiring or connection is defective.	Connect the wiring between the analogue output unit and the analogue output equipment correctly.
		Analogue output unit faulty	Replace the analogue output unit, and check the operation.
		Analogue output equipment faulty	Replace the analogue output equipment, and check the operation. Or, refer to Troubleshooting for the applicable analogue output equipment.
		Abnormal program, etc.	Check that the ladder logic program works correctly.

Problem No.	Error indication	Possible cause	Investigation and countermeasures
9	NFC communication error	NFC communication is not established (communication failure)	<p>Check the following items and check the operation again.</p> <ul style="list-style-type: none"> •Check if the specifications of the NFC reader / writer to be used are appropriate. •Confirm that the settings of the NFC port and PaSoRi of the PC are correct. •Confirm that the NFC reader / writer are connected correctly. •The communication distance is outside of the NFC range. Place the body (area close to NFC antenna) close to the NFC reader / writer.
		NFC reader/writer broken	<p>Replace the NFC reader / writer and check the operation. If the error is not restored after replacement, stop using the equipment and contact your SMC sales representative.</p>

End plate

Model Indication and How to Order

•End plate (D side)

EX600-ED -

End plate at D side Mounting method

Power supply connector

Symbol	Connector	Key type	Function
2	M12 (5 pin)	B code	IN
3	7/8 inch (5 pin)	-	IN
4	M12 (4 pin/5 pin)	A code	IN/OUT (PIN layout 1 *)
5	M12 (4 pin/5 pin)	A code	IN/OUT (PIN layout 2 *)

Symbol	Description
Nil	No DIN rail bracket
2	With DIN rail bracket
3	With DIN rail bracket (Specified for SY series)

*: Refer to Connector Pin No. (page 86) for details of the PIN layout 1 and 2.

•End plate (U side)

EX600-EU -

End plate at U side Mounting method

Specification

Symbol	Description
1	Direct mounting

Symbol	Description
Nil	No DIN rail bracket
2	With DIN rail bracket

Summary of Product parts

•EX600-ED2-□

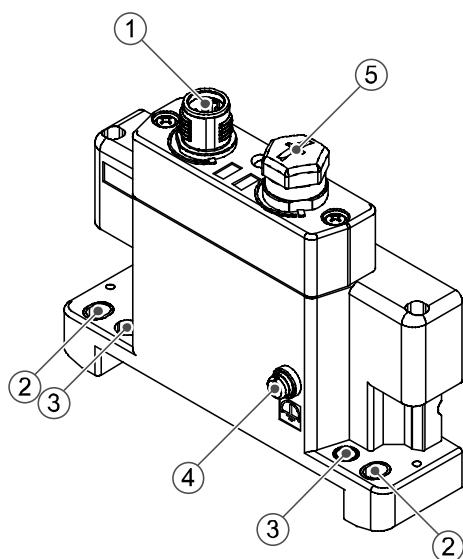

•EX600-ED3-□

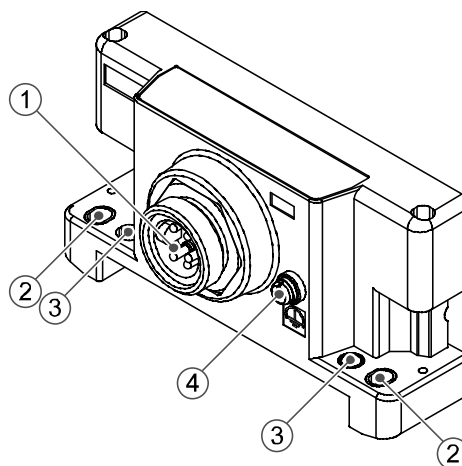

•EX600-EU1-□

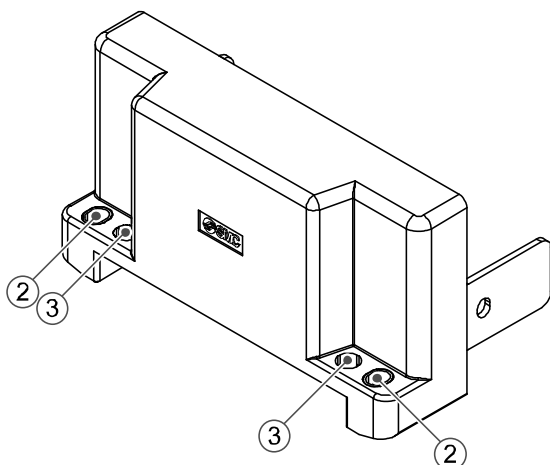

No.	Description	Application
1	Power connector	Supplies power for each unit and input/output devices.
2	Fixing hole for direct mounting	Holes used for direct mounting.
3	DIN rail fixing hole	Holes used for fix DIN rail.
4	F.E. terminal *	Functional Earth terminal - must be connected directly to system earth (ground).
5	Connector (Not used)	Unused connector. Do not remove seal cap.

*: Individual grounding should be provided close to the product with a short cable.

•EX600-ED4/ED5-□

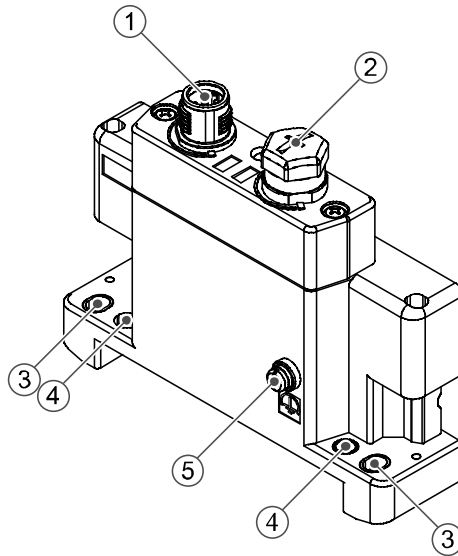

No.	Description	Application
1	Power connector (PWR IN)	Supplies power for each unit and input/output devices.
2	Power connector (PWR OUT)	Provides power to downstream equipment.
3	Fixing hole for direct mounting	Holes used for direct mounting.
4	DIN rail fixing hole	Holes used for fix DIN rail.
5	F.E. terminal *	Functional Earth terminal - must be connected directly to system earth (ground).

*: Individual grounding should be provided close to the product with a short cable.

Mounting and Installation

■Wiring

○Connector pin No.

(1) EX600-ED2-□

PWR IN: M12 5-pin Plug B code

Configuration	Pin No.	Signal name
	1	24 V (Output)
	2	0 V (Output)
	3	24 V (Control and input)
	4	0 V (Control and input)
	5	F.E.

(2) EX600-ED3-□

PWR IN: 7/8 inch 5-pin Plug

Configuration	Pin No.	Signal name
	1	0 V (Output)
	2	0 V (Control and input)
	3	F.E.
	4	24 V (Control and input)
	5	24 V (Output)

(3) EX600-ED4-□

PWR IN: M12 4-pin Plug A code

Configuration	Pin No.	Signal name
	1	24 V (Control and input)
	2	24 V (Output)
	3	0 V (Control and input)
	4	0 V (Output)

PWR OUT: M12 5-pin Socket A code

Configuration	Pin No.	Signal name
	1	24 V (Control and input)
	2	24 V (Output)
	3	0 V (Control and input)
	4	0 V (Output)
	5	Not used

(4) EX600-ED5-□

PWR IN: M12 4-pin Plug A code

Configuration	Pin No.	Signal name
	1	24 V (Output)
	2	0 V (Output)
	3	24 V (Control and input)
	4	0 V (Control and input)

PWR OUT: M12 5-pin Socket A code

Configuration	Pin No.	Signal name
	1	24 V (Output)
	2	0 V (Output)
	3	24 V (Control and input)
	4	0 V (Control and input)
	5	Not used

○Regarding the 2 types of power supply

The power supply consists of two power supply systems as follows:

- Power supply for control and input: Supplying power for control of each unit's power supply for control and also for device connected to input port of the unit.
- Power supply for output: Supplying power for equipment connected to output port of Digital and Analogue unit, and also power supply for valve manifold.

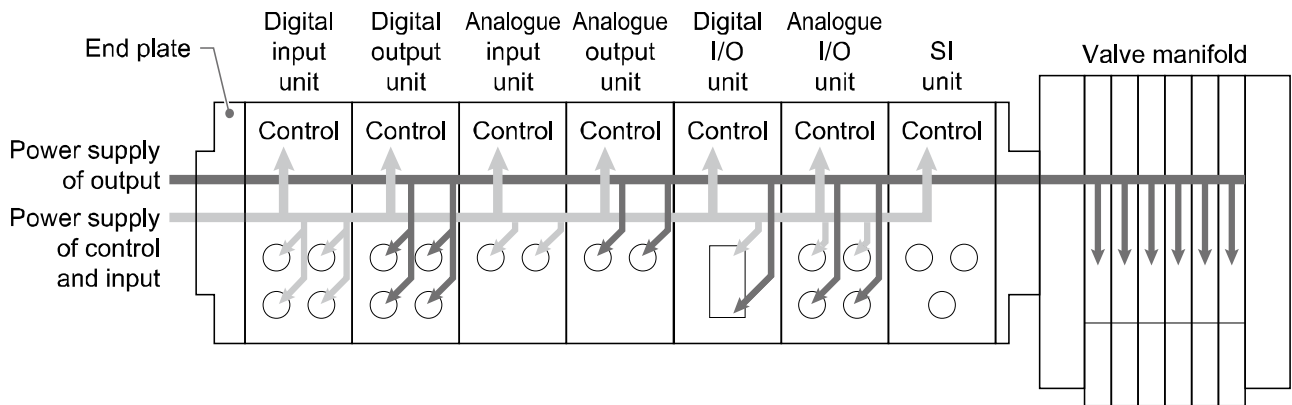

Specifications

Model		EX600-ED2-□	EX600-ED3-□	EX600-ED4-□	EX600-ED5-□	
Power	Power connector	PWR IN	M12 (5-pin) Plug	7/8 inch (5-pin) Plug	M12 (4-pin) Plug	M12 (4-pin) Plug
		PWR OUT	-	-	M12 (5-pin) Socket	M12 (5-pin) Socket
	Power supply (Control and input)		DC24 V ±10%, 2 A	DC24 V ±10%, 8 A	DC24 V ±10%, 4 A	
	Power supply (Output)		DC24 V +10/-5%, 2 A	DC24 V +10/-5%, 8 A	DC24 V +10/-5%, 4 A	
Environment	Enclosure		Conforms to IP67 (With manifold assembled) *1			
	Operating temperature range		-10 to 50 °C			
	Storage temperature range		-20 to 60 °C			
	Operating humidity range		35 to 85%R.H. (No condensation)			
	Withstand voltage		500 VAC for 1 minute between external terminals and F.E.			
Insulation resistance		500 VDC, 10 MΩ min. between external terminals and F.E.				
Standard		UL/CSA(E209424)、CE marking		CE marking		
Weight		170 g	175 g	170 g		

*1: All unused connectors must have a seal cap fitted.

■Dimensions

•EX600-ED2

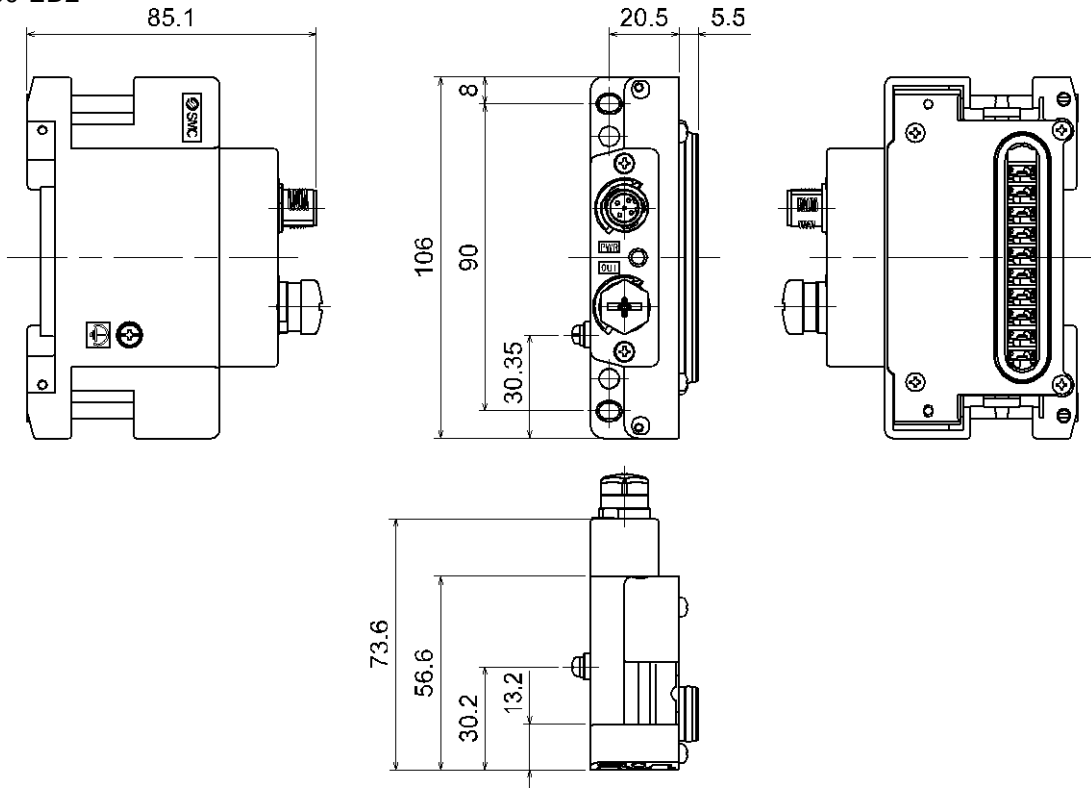

•EX600-ED2-2

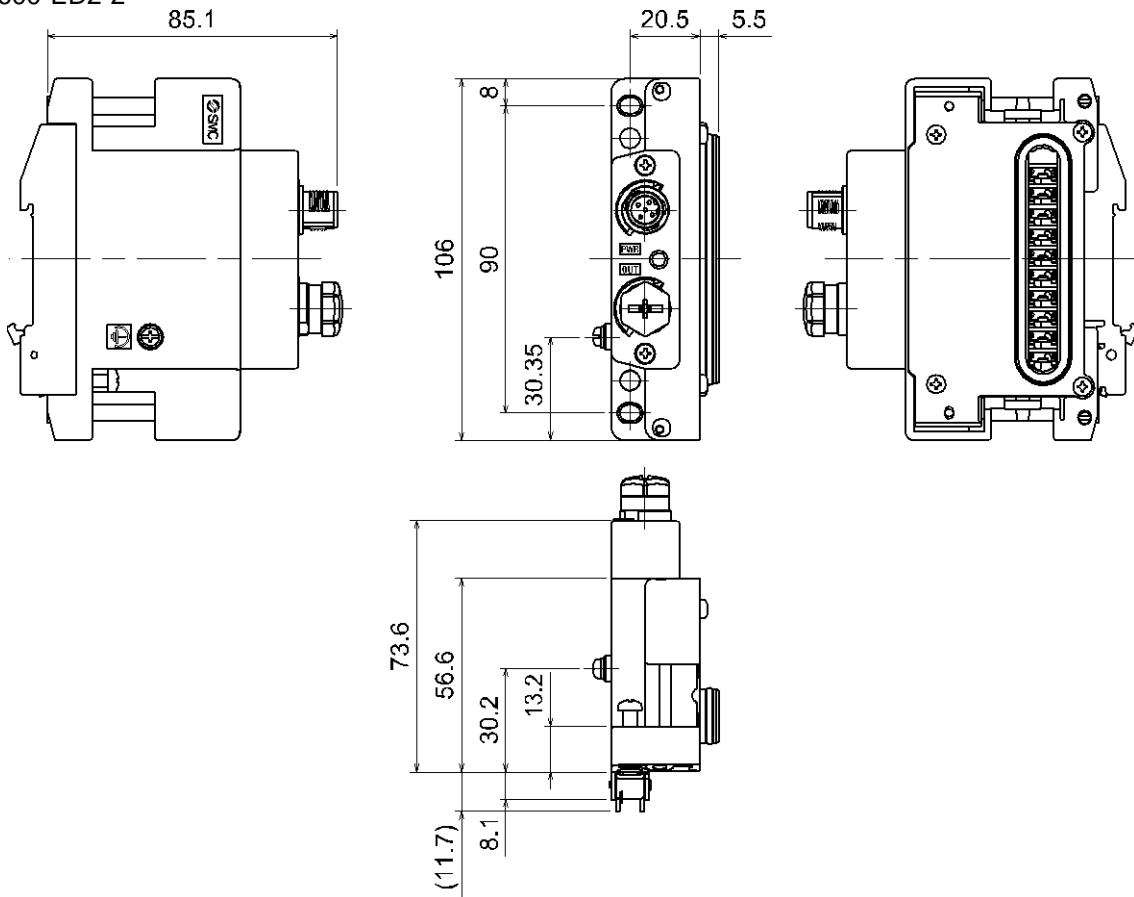

•EX600-ED3

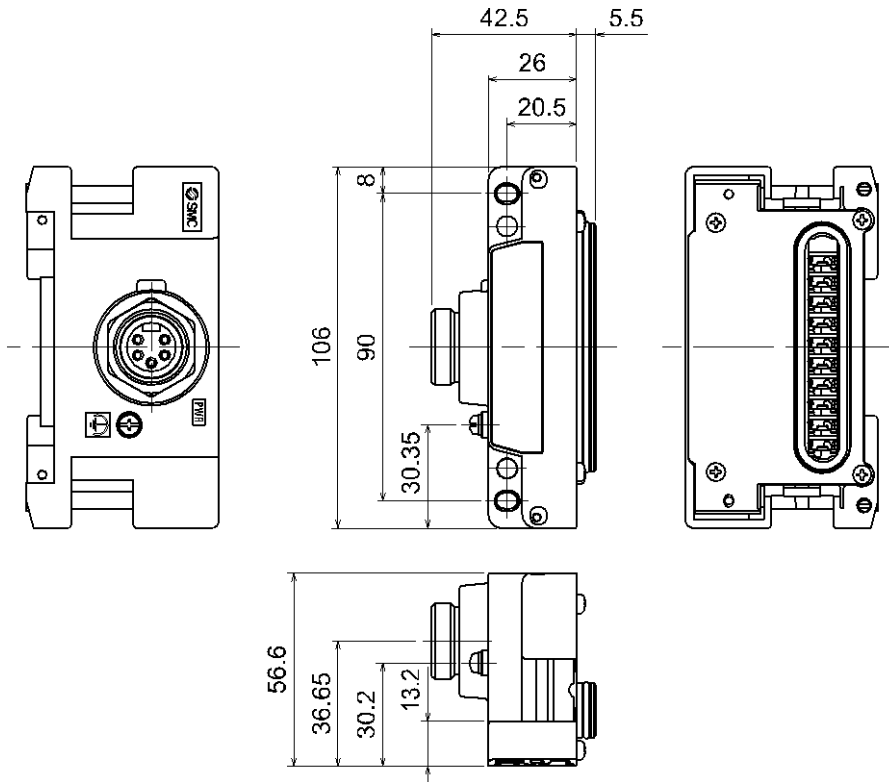

•EX600-ED3-2

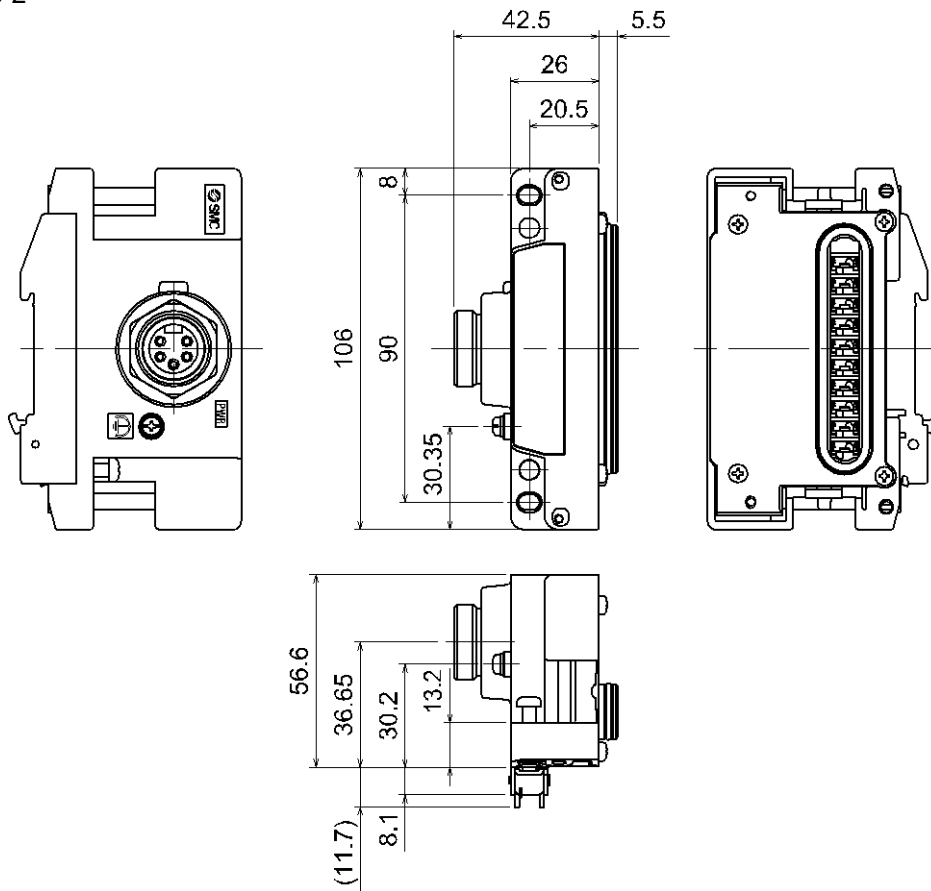

•EX600-ED4/ED5

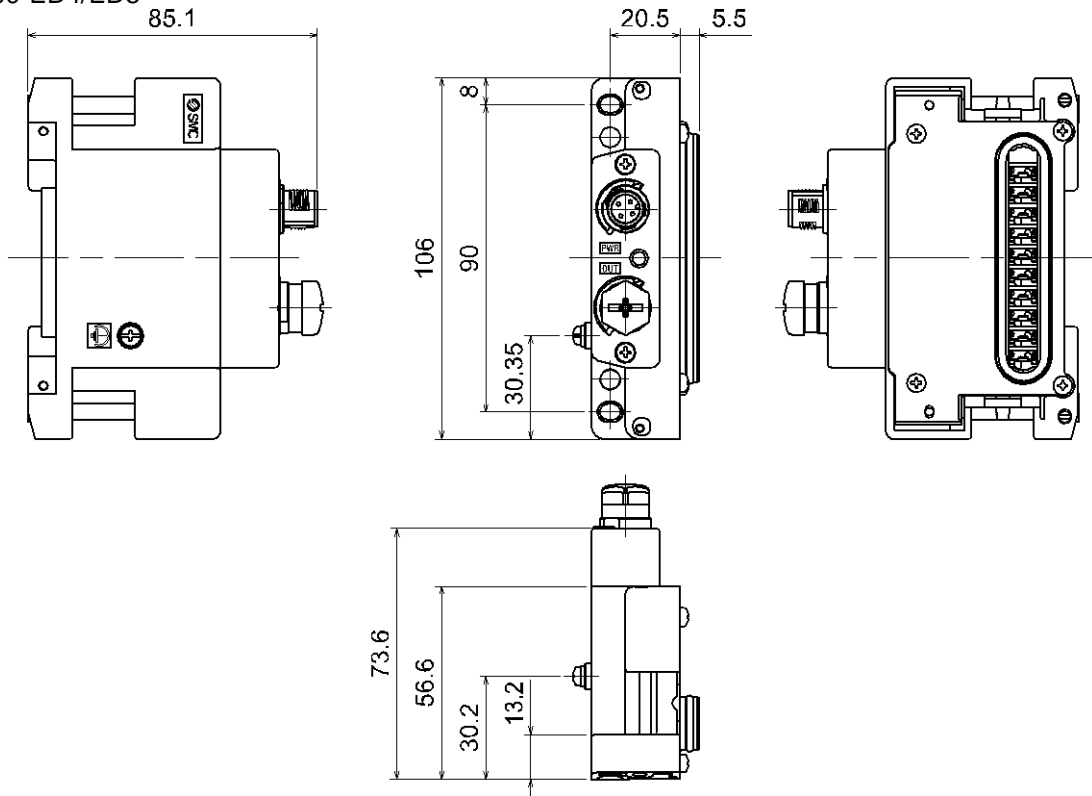

•EX600-ED4/ED5-2

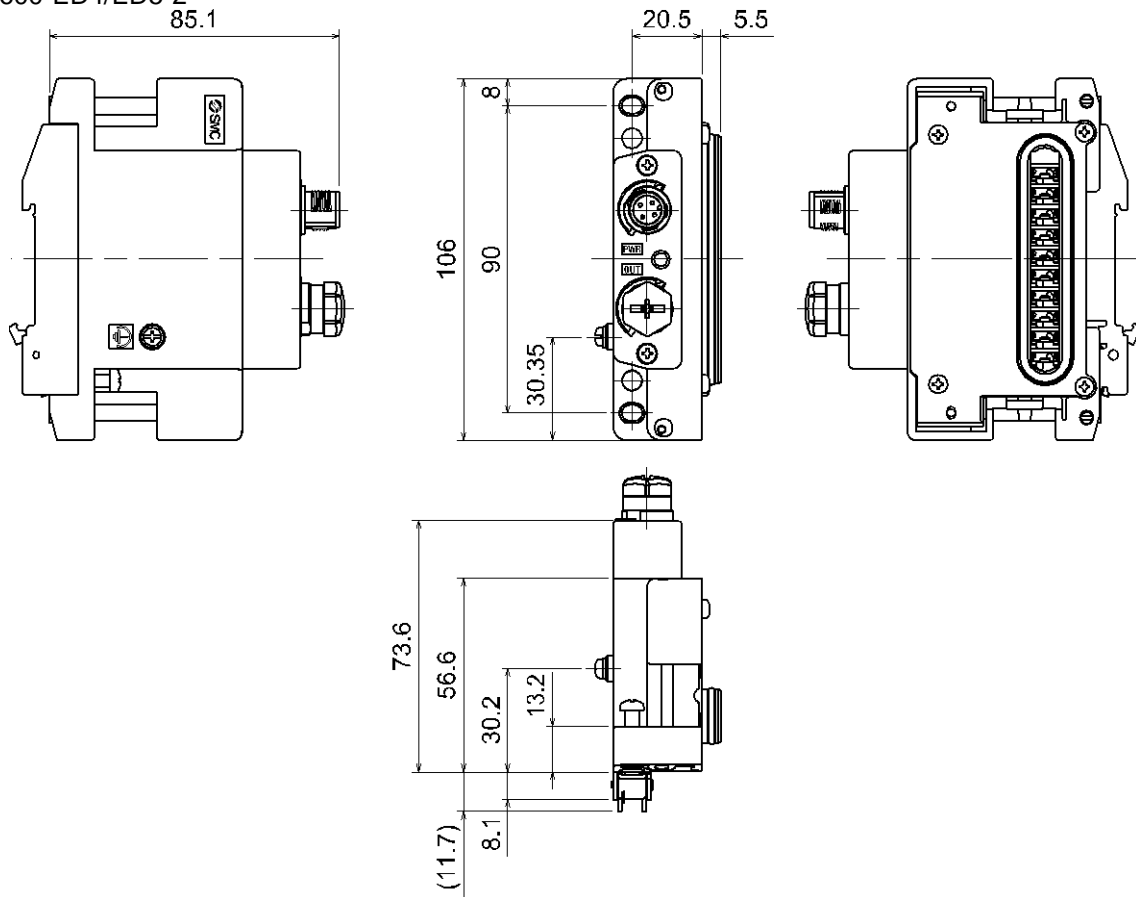

•EX600-EU1

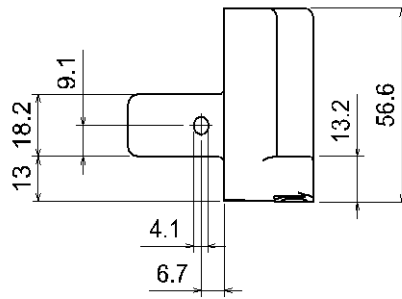
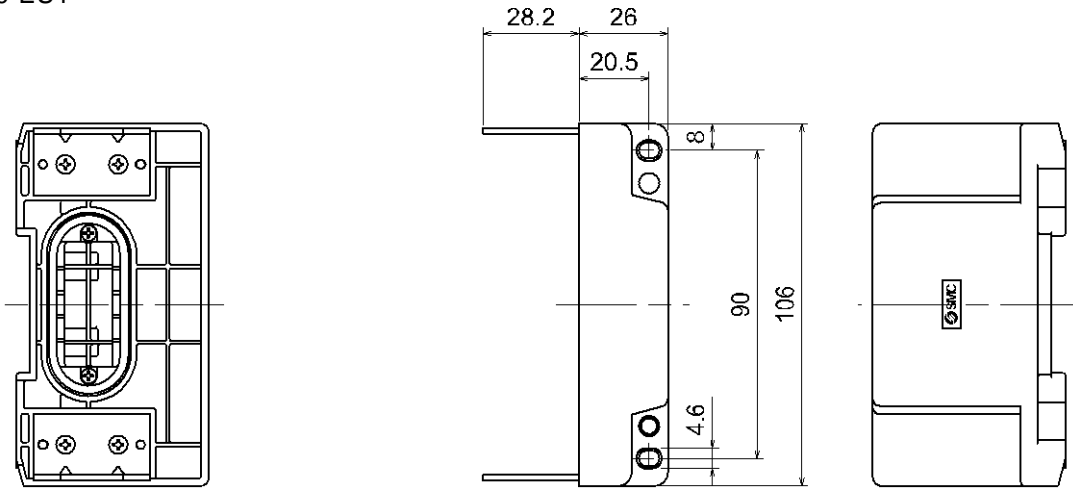

•EX600-EU1-2

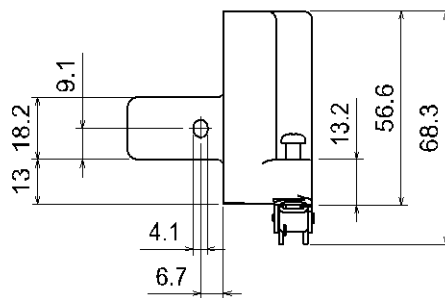
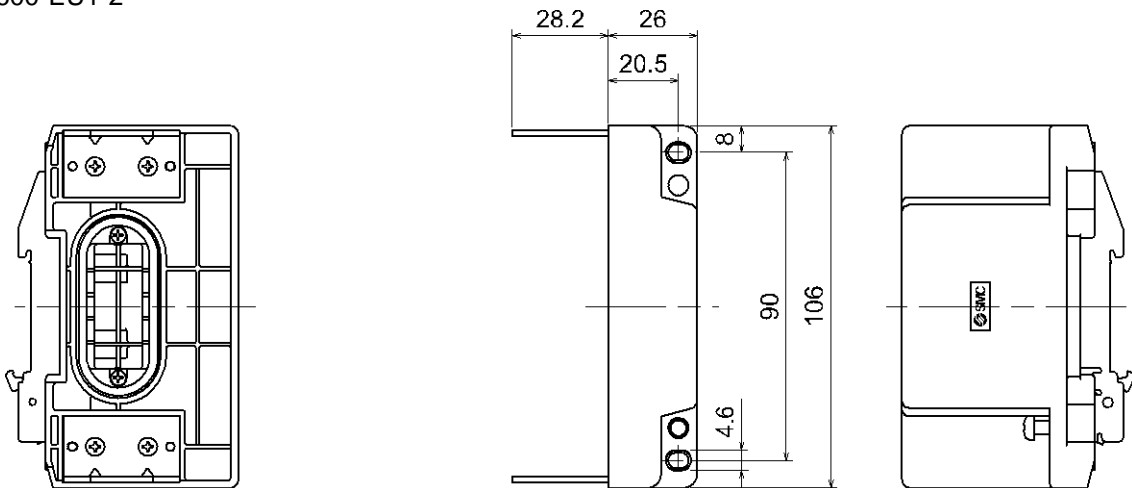

Revision history

SMC Corporation

4-14-1, Sotokanda, Chiyoda-ku, Tokyo 101-0021 JAPAN

Tel: + 81 3 5207 8249 Fax: +81 3 5298 5362

URL <http://www.smcworld.com>

Note: Specifications are subject to change without prior notice and any obligation on the part of the manufacturer.
© 2018 SMC Corporation All Rights Reserved.

