

TEST REPORT

Report No.: 22051391HKG-004

XIONG FA HANG Toy Craft Factory

Application For Certification
(Original Grant)

FCC ID: 2AJDV-1631798TX

Transceiver – 2.4GHz RC Controller

Prepared and Checked by:

Approved by:

Signed on File

Leung Chun Ning, Peter
Assistant Engineer

Wong Kwok Yeung, Kenneth
Assistant Supervisor
Date: August 19, 2022

TEST REPORT

GENERAL INFORMATION

Grantee:	XIONG FA HANG Toy Craft Factory
Grantee Address:	FENGXIN NO.1 ROAD,CHENGHAI DISTRICT, SHANTOU, China.
Contact Person:	Shurong Tan
Tel:	0754-85870311
Fax:	0754-86396311
E-mail:	xiong-fa@163.com
Manufacturer:	XIONG FA HANG Toy Craft Factory
Manufacturer Address:	FENGXIN NO.1 ROAD,CHENGHAI DISTRICT, SHANTOU, China.
Brand Name:	Not Applicable
Model:	1631798
Additional Model:	86040CC, 86040, 86041, 86040CCE, 86041CCE, 1664118, 1664119
Type of EUT:	Transceiver
Description of EUT:	Hasbro 12" Walking Transformers Robot Assorted
Serial Number:	N/A
FCC ID:	2AJDV-1631798TX
Date of Sample Submitted:	May 26, 2022
Date of Test:	May 26, 2022 to June 10, 2022
Report No.:	22051391HKG-004
Report Date:	August 19, 2022
Environmental Conditions:	Temperature: +10 to 40°C Humidity: 10 to 90%
Conclusion:	Test was conducted by client submitted sample. The submitted sample as received complied with the 47 CFR Part 15 Certification.

TEST REPORT

SUMMARY OF TEST RESULT

Test Specification	Reference	Results
Radiated Emission	15.249, 15.209	Complied
Radiated Emission on the Bandedge		
Radiated Emission in Restricted Bands	15.205	Complied

The equipment under test is found to be complying with the following standards:
FCC Part 15, October 1, 2020 Edition

- Note:
1. The EUT uses a permanently attached antenna which, in accordance to section 15.203, is considered sufficient to comply with the pervisions of this section.
 2. Pursuant to FCC part 15 Section 15.215(c), the 20 dB bandwidth of the emission was contained within the frequency band designated (mentioned as above) which the EUT operated. The effects, if any, from frequency sweeping, frequency hopping, other modulation techniques and frequency stability over excepted variations in temperature and supply voltage were considered.

TEST REPORT

TABLE OF CONTENTS

1.0	GENERAL DESCRIPTION.....	5
1.1	Product Description	5
1.2	Related Submittal(s) Grants.....	5
1.3	Test Methodology.....	5
1.4	Test Facility.....	5
2.0	SYSTEM TEST CONFIGURATION.....	6
2.1	Justification	6
2.2	EUT Exercising Software.....	6
2.3	Special Accessories.....	6
2.4	Measurement Uncertainty.....	6
2.5	Support Equipment List and Description	6
3.0	EMISSION RESULTS.....	7
3.1	Field Strength Calculation	7
3.2	Radiated Emission Configuration Photograph.....	8
3.3	Radiated Emission Data	8
4.0	EQUIPMENT PHOTOGRAPHS.....	13
5.0	PRODUCT LABELLING.....	13
6.0	TECHNICAL SPECIFICATIONS	13
7.0	INSTRUCTION MANUAL	13
8.0	MISCELLANEOUS INFORMATION	14
8.1	Radiated Emission on the Bandedge	14
8.2	Emissions Test Procedures.....	15
8.3	Occupied Bandwidth.....	17
9.0	CONFIDENTIALITY REQUEST.....	18
10.0	EQUIPMENT LIST	18

TEST REPORT

1.0 GENERAL DESCRIPTION

1.1 Product Description

The Equipment Under Test (EUT), is a portable 2.4GHz (Controller Unit) for a RC Robot. The sample supplied operated on 50 channels, normally at 2405 - 2475MHz. The channels are shown in below table.

2405	2406	2407	2408	2409
2410	2411	2412	2413	2414
2415	2416	2417	2418	2419
2420	2425	2426	2427	2428
2429	2430	2431	2432	2433
2434	2435	2436	2437	2438
2439	2440	2445	2450	2460
2461	2462	2463	2464	2465
2466	2467	2468	2469	2470
2471	2472	2473	2474	2475

The EUT is powered by 1 x 9V Alkaline battery. After switching on the EUT, the robot will be walked or slid forward or backward and turned left and right based on the switches pressed in the controller. Different sound will be emitted from the robot or the speaker will be turned off based on the buttons pressed in the controller and on the robot. Light will be emitted from the robot, blinked, or turned off based on the buttons pressed in the controller and on the robot.

The Models: 86040CC, 86040, 86041, 86040CCE, 86041CCE, 1664118 and 1664119 are the same as the Model: 1631798 in hardware aspect. The models are difference in model number, item name, color, packaging and non-conductive accessories only as declared by client.

Antenna Type: Internal, Integral

For electronic filing, the brief circuit description is saved with filename: descri.pdf.

1.2 Related Submittal(s) Grants

This is a single application for certification of a transceiver.

The Certification procedure of transceiver for this transceiver (with FCC ID: 2AJDV-1631798RX) is being processed as the same time of this application.

1.3 Test Methodology

Radiated emission measurements were performed according to the procedures in ANSI C63.10 (2013). All radiated measurements were performed in an 3m Chamber. Preliminary scans were performed in the 3m Chamber only to determine worst case modes. All radiated tests were performed at an antenna to EUT distance of 3 meters, unless stated otherwise in the “**Justification Section**” of this Application.

1.4 Test Facility

The 3m Chamber used to collect the radiated data is located at Workshop No. 3, G/F., World-Wide Industrial Centre, 43-47 Shan Mei Street, Fo Tan, Sha Tin, N.T., Hong Kong SAR, China. This test facility and site measurement data have been placed on file with the FCC.

TEST REPORT

2.0 SYSTEM TEST CONFIGURATION

2.1 Justification

The system was configured for testing in a typical fashion (as a customer would normally use it), and in the confines as outlined in ANSI C63.10 (2013).

The device was powered by DC 9.0V (1 x 9V Alkaline battery).

For maximizing emissions, the EUT was rotated through 360°, the antenna height was varied from 1 meter to 4 meters above the ground plane, and the antenna polarization was changed. This step by step procedure for maximizing emissions led to the data reported in Exhibit 3.0.

The unit was operated standalone and placed in the center of the turntable.

The equipment under test (EUT) was configured for testing in a typical fashion (as a customer would normally use it). The EUT was mounted to a plastic stand if necessary and placed on the wooden turntable, which enabled the engineer to maximize emissions through its placement in the three orthogonal axes.

2.2 EUT Exercising Software

There was no special software to exercise the device. Once the unit is powered up, it transmits the RF signal continuously.

2.3 Special Accessories

There are no special accessories necessary for compliance of this product.

2.4 Measurement Uncertainty

Decision Rule for compliance: For FCC/IC standard, the measured value must be within the limits of applicable standard without accounting for the measurement uncertainty. For EN/IEC/HKTA/HKTC standard, conformity rules will be used as per standard directly excepted EN/IEC 61000-3-2, EN/IEC 61000-3-3, HKTA1004, HKCA1008, HKTA1019, HKTA1020, HKTA1041 and HKTA1044. For these excepted or not mentioned standards, Cl 4.2.2 of ILAC-G8:09/2019 decision rules will be reference and guard band will be equal to our measurement uncertainty with 95% confidence level (k=2). In case, the measured value is within guard band region, undetermined decision will be used.

2.5 Support Equipment List and Description

Not Applicable.

TEST REPORT

3.0 EMISSION RESULTS

Data is included of the worst case configuration (the configuration which resulted in the highest emission levels). A sample calculation, configuration photographs and data tables of the emissions are included.

3.1 Field Strength Calculation

The field strength is calculated by adding the Antenna Factor and Cable Factor, and subtracting the Amplifier Gain (if any), Average Factor (optional) from the measured reading.

The basic equation with a sample calculation is as follows:

$$FS = RA + AF + CF - AG - AV$$

where

- FS = Field Strength in dB μ V/m
- RA = Receiver Amplitude (including preamplifier) in dB μ V
- AF = Antenna Factor in dB
- CF = Cable Attenuation Factor in dB
- AG = Amplifier Gain in dB
- AV = Average Factor in dB

In the following table(s), the reading shown on the data table reflects the preamplifier gain.

An example for the calculations in the following table is as follows:

$$FS = RR + LF$$

where

- FS = Field Strength in dB μ V/m
- RR = RA - AG - AV in dB μ V
- LF = CF + AF in dB

Assume a receiver reading of 52.0 dB μ V is obtained. The antenna factor of 7.4 dB and cable factor of 1.6 dB are added. The amplifier gain of 29.0 dB and average factor of 5.0 dB are subtracted, giving a field strength of 27.0 dB μ V/m. This value in dB μ V/m was converted to its corresponding level in μ V/m.

RA = 52.0 dB μ V/m	
AF = 7.4 dB	RR = 18.0 dB μ V
CF = 1.6 dB	LF = 9.0 dB
AG = 29.0 dB	
AV = 5.0 dB	
FS = RR + LF	
FS = 18 + 9 = 27 dB μ V/m	

Level in μ V/m = Common Antilogarithm [(27 dB μ V/m)/20] = 22.4 μ V/m

TEST REPORT

3.2 Radiated Emission Configuration Photograph

The worst case in radiated emission was found at 4810 MHz

For electronic filing, the worst case radiated emission configuration photographs are saved with filename: radiated photos.pdf.

3.3 Radiated Emission Data

The data on the following page lists the significant emission frequencies, the limit and the margin of compliance. Numbers with a minus sign are below the limit.

Judgment: Passed by 13.7 dB

TEST REPORT

RADIATED EMISSIONS

Model: 1631798
Date of Test: June 10, 2022
Worst-Case Operating Mode: Transmitting

Table 1
Pursuant to FCC Part 15 Section 15.249 Requirement

Lowest Channel

Polarization	Frequency (MHz)	Reading (dBµV)	Pre-Amp Gain (dB)	Antenna Factor (dB)	Net at 3m - Average (dBµV/m)	Average Limit at 3m (dBµV/m)	Margin (dB)
V	2405.000	78.4	33	29.4	74.8	94.0	-19.2
V	2400.000	40.5	33	29.4	36.9	54.0	-17.1
H	4810.000	32.6	33	34.9	34.5	54.0	-19.5
H	7215.000	23.0	33	37.9	27.9	54.0	-26.1
H	9620.000	27.1	33	40.4	34.5	54.0	-19.5
V	12025.000	26.7	33	40.5	34.2	54.0	-19.8
H	14430.000	30.5	33	40.0	37.5	54.0	-16.5

Polarization	Frequency (MHz)	Reading (dBµV)	Pre-Amp Gain (dB)	Antenna Factor (dB)	Net at 3m - Peak (dBµV/m)	Peak Limit at 3m (dBµV/m)	Margin (dB)
V	2405.000	100.5	33	29.4	96.9	114.0	-17.1
V	2400.000	61.1	33	29.4	57.5	74.0	-16.5
H	4810.000	58.4	33	34.9	60.3	74.0	-13.7
H	7215.000	42.2	33	37.9	47.1	74.0	-26.9
H	9620.000	39.4	33	40.4	46.8	74.0	-27.2
V	12025.000	39.1	33	40.5	46.6	74.0	-27.4
H	14430.000	43.3	33	40.0	50.3	74.0	-23.7

- NOTES:
1. Peak Detector Data unless otherwise stated.
 2. Average detector is applied according to ANSI C63.10.
 3. All measurements were made at 3 meters.
 4. Negative value in the margin column shows emission below limit.
 5. Horn antenna is used for the emission over 1000MHz.
 6. Emissions within the restricted band meet the requirement of FCC Part 15 Section 15.205.
 7. Measurement Uncertainty is ± 5.3 dB at a level of confidence of 95%.

TEST REPORT

RADIATED EMISSIONS

Model: 1631798
Date of Test: June 10, 2022
Worst-Case Operating Mode: Transmitting

Table 2
Pursuant to FCC Part 15 Section 15.249 Requirement

Middle Channel

Polarization	Frequency (MHz)	Reading (dBμV)	Pre-Amp Gain (dB)	Antenna Factor (dB)	Net at 3m - Average (dBμV/m)	Average Limit at 3m (dBμV/m)	Margin (dB)
V	2440.000	79.0	33	29.4	75.4	94.0	-18.6
V	4880.000	32.6	33	34.9	34.5	54.0	-19.5
V	7320.000	29.0	33	37.9	33.9	54.0	-20.1
V	9760.000	27.4	33	40.4	34.8	54.0	-19.2
H	12200.000	25.8	33	40.5	33.3	54.0	-20.7
H	14640.000	32.8	33	38.4	38.2	54.0	-15.8

Polarization	Frequency (MHz)	Reading (dBμV)	Pre-Amp Gain (dB)	Antenna Factor (dB)	Net at 3m - Peak (dBμV/m)	Peak Limit at 3m (dBμV/m)	Margin (dB)
V	2440.000	101.3	33	29.4	97.7	114.0	-16.3
V	4880.000	57.5	33	34.9	59.4	74.0	-14.6
V	7320.000	48.5	33	37.9	53.4	74.0	-20.6
V	9760.000	41.1	33	40.4	48.5	74.0	-25.5
H	12200.000	39.2	33	40.5	46.7	74.0	-27.3
H	14640.000	46.3	33	38.4	51.7	74.0	-22.3

- NOTES:
1. Peak Detector Data unless otherwise stated.
 2. Average detector is applied according to ANSI C63.10.
 3. All measurements were made at 3 meters.
 4. Negative value in the margin column shows emission below limit.
 5. Horn antenna is used for the emission over 1000MHz.
 6. Emissions within the restricted band meet the requirement of FCC Part 15 Section 15.205.
 7. Measurement Uncertainty is ±5.3dB at a level of confidence of 95%.

TEST REPORT

RADIATED EMISSIONS

Model: 1631798
Date of Test: June 10, 2022
Worst-Case Operating Mode: Transmitting

Table 3
Pursuant to FCC Part 15 Section 15.249 Requirement

Highest Channel

Polarization	Frequency (MHz)	Reading (dBµV)	Pre-Amp Gain (dB)	Antenna Factor (dB)	Net at 3m - Average (dBµV/m)	Average Limit at 3m (dBµV/m)	Margin (dB)
V	2475.000	77.1	33	29.4	73.5	94.0	-20.5
V	2483.500	41.0	33	29.4	37.4	54.0	-16.6
H	4950.000	30.6	33	34.9	32.5	54.0	-21.5
V	7425.000	24.9	33	37.9	29.8	54.0	-24.2
H	9900.000	26.4	33	40.4	33.8	54.0	-20.2
V	12375.000	25.0	33	40.5	32.5	54.0	-21.5
V	14850.000	32.4	33	38.4	37.8	54.0	-16.2

Polarization	Frequency (MHz)	Reading (dBµV)	Pre-Amp Gain (dB)	Antenna Factor (dB)	Net at 3m - Peak (dBµV/m)	Peak Limit at 3m (dBµV/m)	Margin (dB)
V	2475.000	99.0	33	29.4	95.4	114.0	-18.6
V	2483.500	58.8	33	29.4	55.2	74.0	-18.8
H	4950.000	54.6	33	34.9	56.5	74.0	-17.5
V	7425.000	46.9	33	37.9	51.8	74.0	-22.2
H	9900.000	40.5	33	40.4	47.9	74.0	-26.1
V	12375.000	38.3	33	40.5	45.8	74.0	-28.2
V	14850.000	45.9	33	38.4	51.3	74.0	-22.7

- NOTES:
1. Peak Detector Data unless otherwise stated.
 2. Average detector is applied according to ANSI C63.10.
 3. All measurements were made at 3 meters.
 4. Negative value in the margin column shows emission below limit.
 5. Horn antenna is used for the emission over 1000MHz.
 6. Emissions within the restricted band meet the requirement of FCC Part 15 Section 15.205.
 7. Measurement Uncertainty is ± 5.3 dB at a level of confidence of 95%.

TEST REPORT

RADIATED EMISSIONS

Model: 1631798
Date of Test: June 10, 2022
Worst-Case Operating Mode: Transmitting

Table 4
Pursuant to FCC Part 15 Section 15.209 Requirement

Polarization	Frequency (MHz)	Reading (dBµV)	Pre-amp (dB)	Antenna Factor (dB)	Net at 3m (dBµV/m)	Limit at 3m (dBµV/m)	Margin (dB)
V	30.000	23.3	16	10.0	17.3	40.0	-22.7
V	72.316	25.9	16	7.0	16.9	40.0	-23.1
V	118.028	19.6	16	14.0	17.6	43.5	-25.9
H	495.843	14.3	16	26.0	24.3	46.0	-21.7
H	675.535	16.4	16	29.0	29.4	46.0	-16.6
H	943.983	14.8	16	33.0	31.8	46.0	-14.2

- NOTES:
1. Peak Detector Data unless otherwise stated.
 2. All measurements were made at 3 meters.
 3. Negative value in the margin column shows emission below limit.
 4. Horn antenna is used for the emission over 1000MHz.
 5. Emissions within the restricted band meet the requirement of FCC Part 15 Section 15.205.
 6. Measurement Uncertainty is ±5.3dB at a level of confidence of 95%.

TEST REPORT

4.0 EQUIPMENT PHOTOGRAPHS

For electronic filing, the photographs are saved with filename: external photos.pdf and internal photos.pdf.

5.0 PRODUCT LABELLING

For electronics filing, the FCC ID label artwork and the label location are saved with filename: label.pdf.

6.0 TECHNICAL SPECIFICATIONS

For electronic filing, the block diagram and schematic of the tested EUT are saved with filename: block.pdf and circuit.pdf respectively.

7.0 INSTRUCTION MANUAL

For electronic filing, a preliminary copy of the Instruction Manual is saved with filename: manual.pdf.

This manual will be provided to the end-user with each unit sold/leased in the United States.

TEST REPORT

8.0 MISCELLANEOUS INFORMATION

The miscellaneous information includes details of the test procedure and measured bandwidth.

8.1 Radiated Emission on the Bandedge

The emission of bandedge data were shown on the above radiated data table of 1 & 3 respectively.

Emissions radiated outside of the specified frequency bands, except harmonics, are attenuated by 50dB below the level of the fundamental or to the general radiated emissions limits in Section 15.209, whichever is the lesser attenuation, which meet the requirement of Part 15.249(d).

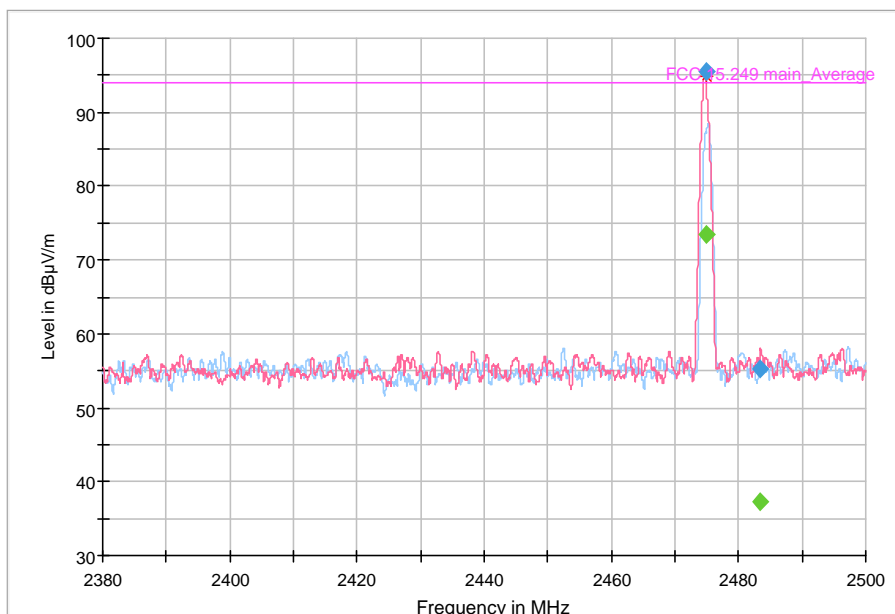
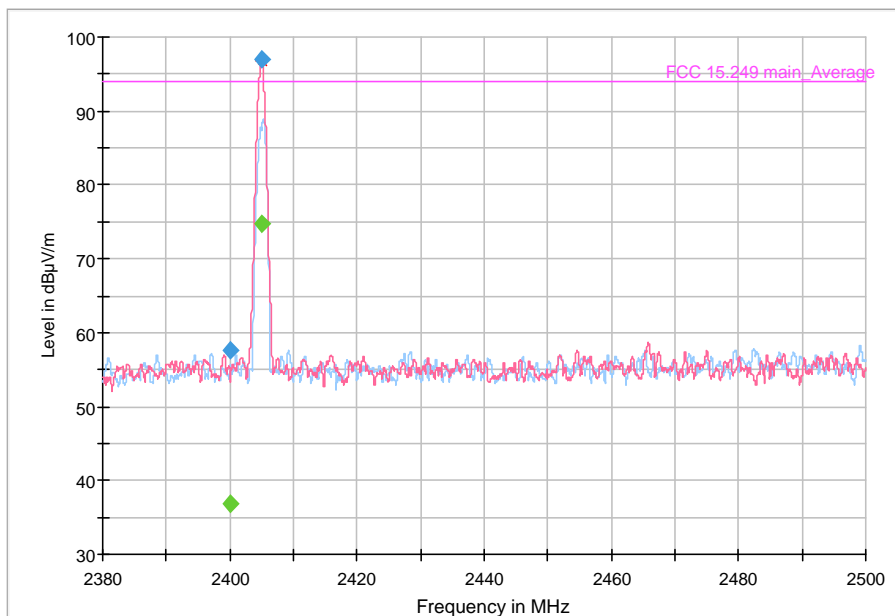

TEST REPORT

8.2 Emissions Test Procedures

The following is a description of the test procedure used by Intertek Testing Services Hong Kong Ltd. in the measurements of transmitter operating under the Part 15, Subpart C rules.

The transmitting equipment under test (EUT) is placed on a wooden turntable which is four feet in diameter and approximately 0.8m in height above the ground plane for emission measurement at or below 1GHz and 1.5m in height above the ground plane for emission measurement above 1GHz. During the radiated emissions test, the turntable is rotated and any cables leaving the EUT are manipulated to find the configuration resulting in maximum emissions. The EUT is adjusted through all three orthogonal axis to obtain maximum emission levels. The antenna height and polarization are also varied during the testing to search for maximum signal levels. The height of the antenna is varied from one to four meters.

Detector function for radiated emissions is in peak mode. Average readings, when required, are taken by measuring the duty cycle of the equipment under test and subtracting the corresponding amount in dB from the measured peak readings. A detailed description for the calculation of the average factor can be found in Exhibit 8.3.

The frequency range scanned is from the lowest radio frequency signal generated in the device which is greater than 9 kHz to the tenth harmonic of the highest fundamental frequency or 40 GHz, whichever is lower.

The EUT is warmed up for 15 minutes prior to the test.

AC power to the unit is varied from 85% to 115% nominal and variation in the fundamental emission field strength is recorded. If battery powered, a new, fully charged battery is used.

Conducted measurements were made as described in ANSI C63.10 (2013).

The IF bandwidth used for measurement of radiated signal strength was 100 kHz or greater when frequency is below 1000 MHz. Where pulsed transmissions of short enough pulse duration warrant, a greater bandwidth is selected according to the recommendations of Hewlett Packard Application Note 150-2. A discussion of whether pulse desensitivity is applicable to this unit is included in this report (See Exhibit 8.1). Above 1000 MHz, a resolution bandwidth of 1 MHz is used.

Transmitter measurements are normally conducted at a measurement distance of three meters. However, to assure low enough noise floor in the forbidden bands and above 1 GHz, signals are acquired at a distance of one meter or less. All measurements are extrapolated to three meters using inverse scaling, unless otherwise reported. Measurements taken at a closer distance are so marked.

TEST REPORT

8.2.1 Radiated Emission Test Setup

The figure below shows the test setup, which is utilized to make these measurements.

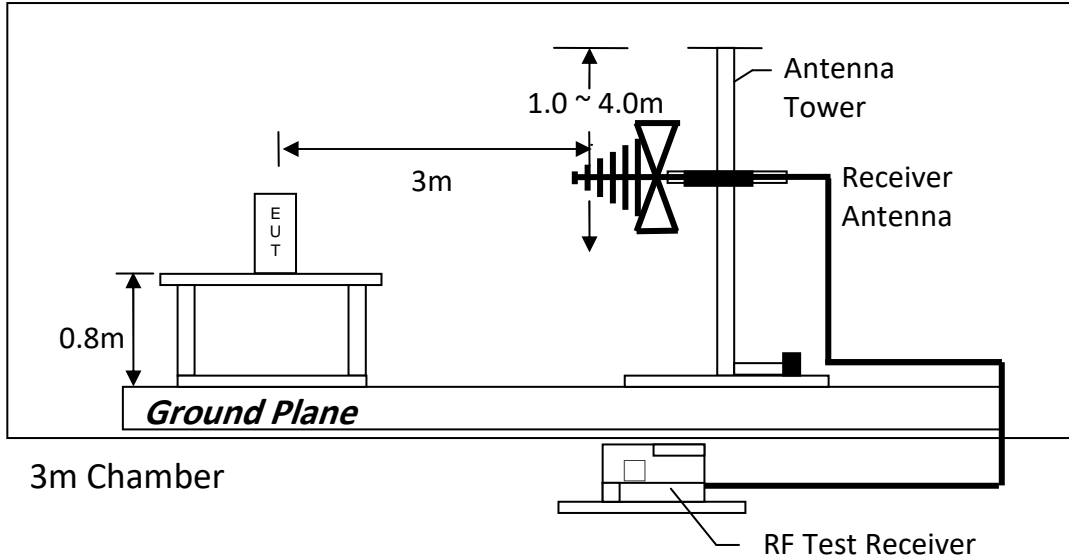

Test setup of radiated emissions up to 1GHz

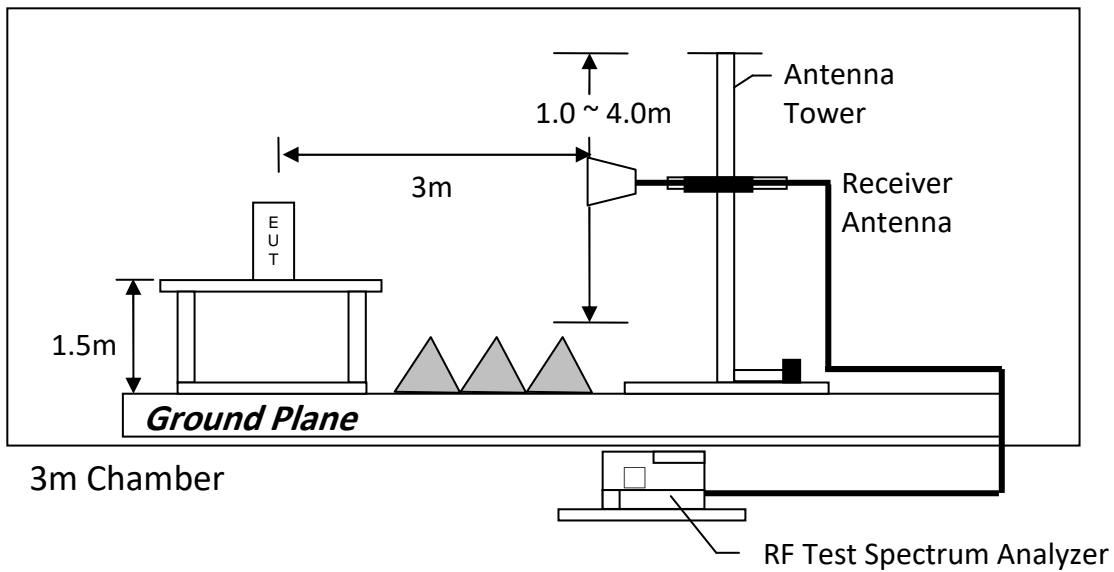

Test setup of radiated emissions above 1GHz

TEST REPORT

8.3 Occupied Bandwidth

Occupied Bandwidth Results:

Occupied Bandwidth (kHz)	
Low Channel: 2405	820
Middle Channel: 2440	760
High Channel: 2475	800

The worst case is shown as below

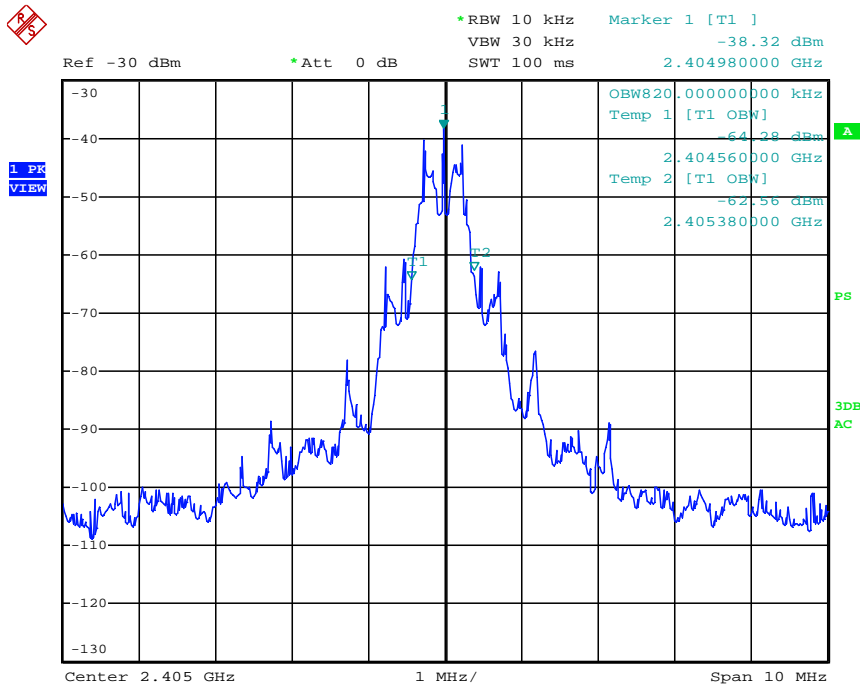

TEST REPORT

9.0 CONFIDENTIALITY REQUEST

For electronic filing, a preliminary copy of the confidentiality request is saved with filename: request.pdf.

10.0 EQUIPMENT LIST

1) Radiated Emissions Test

Equipment	Signal and Spectrum Analyzer (10Hz to 40GHz)	Biconical Antenna (20MHz to 200MHz)	EMI Test Receiver 7GHz
Registration No.	EW-3016	EW-3061	EW-3481
Manufacturer	ROHDESCHWARZ	EMCO	ROHDESCHWARZ
Model No.	FSV40	3142E	ESR7
Calibration Date	October 29, 2021	February 02, 2021	December 21, 2021
Calibration Due Date	October 29, 2022	August 02, 2022	December 21, 2022

Equipment	Log Periodic Antenna	Double Ridged Guide Antenna	Active Loop H-field (9kHz to 30MHz)
Registration No.	EW-3243	EW-1133	EW-3302
Manufacturer	EMCO	EMCO	EMCO
Model No.	3148B	3115	6502
Calibration Date	June 03, 2021	May 26, 2021	July 26, 2021
Calibration Due Date	December 30, 2022	November 26, 2022	July 26, 2022

Equipment	RF Preampfier (9kHz to 6000MHz)	2.4GHz Notch Filter	14m Double Shield RF Cable (20MHz to 6GHz)
Registration No.	EW-3006b	EW-3435	EW-2074
Manufacturer	SCHWARZBECK	MICROWAVE	RADIALL
Model No.	BBV9718	N0324413	N(m)-RG142-BNC(m) L=14M
Calibration Date	February 15, 2022	November 16, 2019	November 14, 2019
Calibration Due Date	February 15, 2023	June 16, 2022	August 14, 2022

Equipment	Pyramidal Horn Antenna
Registration No.	EW-0905
Manufacturer	EMCO
Model No.	3160-09
Calibration Date	July 20, 2021
Calibration Due Date	January 20, 2023

TEST REPORT

2) Bandedge Measurement

Equipment	Spectrum Analyzer
Registration No.	EW-2466
Manufacturer	ROHDESCHWARZ
Model No.	FSP30
Calibration Date	November 18, 2019
Calibration Due Date	August 18, 2022

3) OBW Measurement

Equipment	Spectrum Analyzer
Registration No.	EW-2466
Manufacturer	ROHDESCHWARZ
Model No.	FSP30
Calibration Date	November 18, 2019
Calibration Due Date	August 18, 2022

4) Control Software for Radiated Emission

Software Information	
Software Name	EMC32
Manufacturer	ROHDESCHWARZ
Software version	10.50.40

END OF TEST REPORT