

Statement

- This manual is designed for the use of FCAR products; it cannot be copied or stored in any form (electronic, mechanical, photocopying, recording or otherwise) without prior written permission being secured from Shenzhen FCAR Technology Co., Ltd.
- This manual is intended for professional vehicle repair technicians.
- This manual provides the operation methods for FCAR products only, and the company accepts no responsibility for the consequences caused by attempting to use the operation methods on other equipment.
- The company shall not accept any responsibility for accidents caused either by the user personally or anyone else, or costs and expenses due to equipment damages including equipment loss caused by the user's abuse or misuse, arbitrary changes or repairs or operation of the equipment in a manner not in accordance with the manual requirements.
- This manual is written in accordance with the existing configuration and functions of the product, and is subject to change without notice if the product adds new configurations and functions.

If you have any questions, please contact us by the following ways:

Headquarters: 8F, Chuangyi Bldg., No. 3025 Nanhai Ave., Nanshan, Shenzhen, China
518060

Tel: 0086-755-82904730

Fax: 0086-755-83147605

E-mail: marketing@szfcar.com

Website: <http://www.fcar.com>

Registered trademark

The company has registered the  trademark in mainland China. The company declares that the ownership of the registered trademark, service mark, domain name, logo, and company name in countries in which they have not yet been registered belongs to the company. Other products and their company name trademarks mentioned in this manual belong to the original registered company. The trademarks, service marks, domain names, logos, company names or other companies mentioned may not be used without prior written permission of the owner.

FCAR Series Host Machine Maintenance and Use Cautions

- Do not allow unauthorized disassembly.
- Avoid strong impacts to the equipment.
- Avoid proximity to any magnetic field.
- Do not keep this machine in a high temperature environment for any length of time.
- Do not keep this machine in a low temperature environment for any length of time.
- Do not forcefully click on the screen or click the screen with sharp tools.
- Do not use water and chemical solvents to clean the machine, please use a soft clean cloth and neutral detergent instead.

Automobile Inspection Notes

- Follow the standard safety rules of the auto repair industry to operate. Be especially careful to avoid impact or damage caused by environmental factors such as the surrounding pH, poison gas or high pressure environment.
- Vehicle battery fluid contains sulfuric acid, which is corrosive to the skin. During the operation, avoid direct contact with the battery fluid, in particular being careful not to splash into the eyes. Keep away from fire.
- The engine exhaust gas contains a variety of toxic compounds, which one should avoid breathing in. During the operation, park the vehicle in a well-ventilated

place.

- When the engine is running, the temperature is very high; please avoid contact with the water tank, exhaust pipe and other high temperature components.
- Before starting the engine, apply the handbrake and place the shift lever in Gear Neutral (Manual Transmission) or P (Automatic Transmission) to avoid sudden movements of the vehicle when starting the engine.
- Before repairing the vehicle, apply the parking brake, engage the Neutral or P range, and lower the driver seat's glass doors.
- If the engine can be started, warm-up the vehicle to normal temperature (water temperature is about 80 °C), and turn off the auxiliary electrical appliances (such as air conditioning, lighting, sound, etc.).
- Find the diagnostic socket of this car; check and confirm the diagnostic socket cables are in good condition, connecting the main unit for diagnosis. Otherwise, do not test, to avoid damage to the main unit. If necessary, use a multimeter to measure the voltage of the diagnostic socket.

CONTENTS

1	PRODUCT INTRODUCTION	6
1.1	Host Structure	6
1.2	VCI Box Structure.....	8
2	HOST ON/OFF AND FUNCTION MENU.....	9
2.1	Host Charging	9
2.2	Booting	10
2.3	Shutdown	10
2.4	Introduction to Each Menu Option	10
3	PREPARATION BEFORE DIAGNOSIS	13
3.1	Technical Requirements Before Diagnosis	14
3.1.1	<i>Equipment Requirements</i>	<i>14</i>
3.1.2	<i>Vehicle Requirements.....</i>	<i>14</i>
3.1.3	<i>Technician Request.....</i>	<i>15</i>
3.2	Vehicle Connection.....	15
3.2.1	<i>Connect VCI Box to Vehicle.....</i>	<i>15</i>
3.2.2	<i>Host and VCI Box Connection.....</i>	<i>17</i>
3.3	Vehicle Models Selection	19
3.3.1	<i>Manual Selection.....</i>	<i>20</i>
3.3.2	<i>Automatic Identification</i>	<i>21</i>
3.3.3	<i>Direct Access to Vehicle System</i>	<i>21</i>
3.3.4	<i>Automatic Scan VIN Code.....</i>	<i>21</i>
3.3.5	<i>Manual Input VIN Code</i>	<i>22</i>
3.3.6	<i>General OBD Access Mode</i>	<i>22</i>
3.4	Diagnosis and Other High-Level Function	22
3.4.1	<i>Diagnostic Function Main Interface</i>	<i>23</i>
3.5	Diagnosis	24
3.5.1	<i>Read Fault Code</i>	<i>26</i>
3.5.2	<i>Erase Fault Cede.....</i>	<i>27</i>
3.5.3	<i>Read Live Data</i>	<i>28</i>

3.5.4	Actuation Test	31
3.6	Special Function.....	34
3.7	General OBDII	35
4	CHINESE HD DIAGNOSIS.....	35
5	DETECT TOOLBOX	36
5.1	Node Screening	37
5.2	Pin Detecting	38
6	DATA MANAGEMENT.....	39
7	REMOTE ASSISTANCE.....	40
8	REFERENCE.....	41
9	UPDATE.....	41
10	SETTING	42
10.1	Language	42
10.2	Unit	43
10.3	User Info	43
10.4	Self Test	44
10.5	Activation	44
10.6	Push	45
10.7	Data Cleaning	46
10.8	About Us.....	46
10.9	System Setting.....	46
WARRANTY.....		47

1 Product Introduction

The product is an integrated automotive computer fault diagnostic instrument aimed at the testing and diagnosis of gasoline, diesel, natural gas and other electronic control systems. The product is applicable to large and small service companies, training institutions, automobile manufacturers, repair stations, diesel engine manufacturers, mining machinery, petrochemical, energy and other enterprises.

The software is comprehensively configured, and vehicle data and information in it are authoritative and fully meet the strict requirements of customers' detection breadth and depth. The software covers thousands of vehicle model data, and provides a powerful help system with maintenance information, enabling users to deal with the problems in practical work easily and quickly, thereby increasing the efficiency and technical level and reflecting the advantage of professional level quality.

1.1 Host Structure

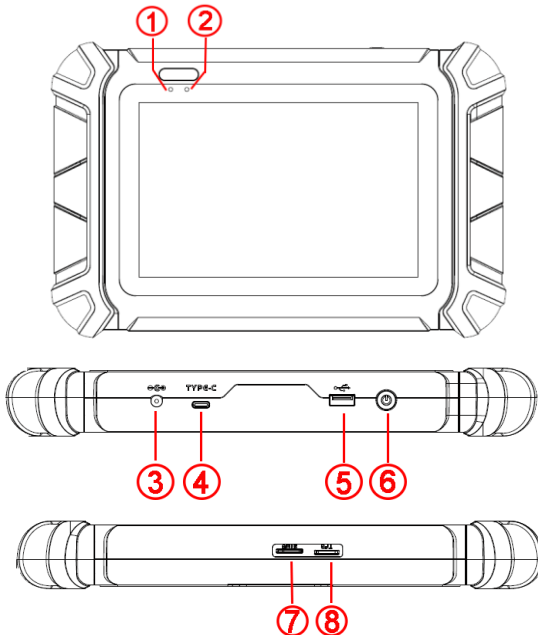

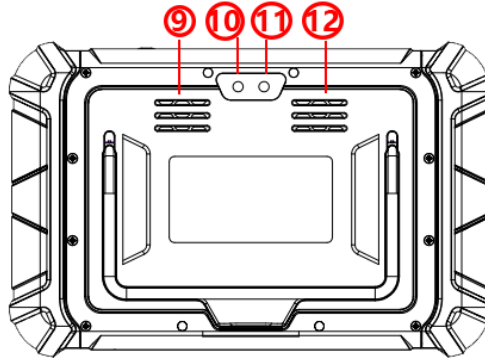

Serial No.	Name	Serial No.	Name
①	Power indicator	②	Light sensor
③	DC power port	④	USB Type-C port
⑤	USB port	⑥	Power switch
⑦	SIM card socket	⑧	TF card socket
⑨	Speaker port	⑩	Camera
⑪	Flash lamp	⑫	Heat dissipation hole

Host parameter

System	Android11 multiple task operating system
Processor	Cortex-A55 RK3566 Quad-core, 1.8GHz architecture processor
Touch screen	8" Multi touch capacitive screen, TP thickness:1.1mm
Memory	4GB RAM & 64GB ROM, besides supporting 64GB TF memory card
Connection	Wi-Fi & Bluetooth 2.0/4.0

Camera	Rear camera 8 million pixels, supporting Autofocus
Battery capacity	3.7V/10000mAh
Interface	USB(A Shape), USB(Type C), TF card slot, DC power interface, SIM Card Socket(Reserved)
Size	282mm*184mm*36mm
Operation Temperature	0°C to 40°C
Store Temperature	-20°C to 60°C

1.2 VCI Box Structure

Fcar offers a variety of VCI boxes. The functions and connection methods of each model are similar. The following is an example of FV100.

FV100 Structure Description:

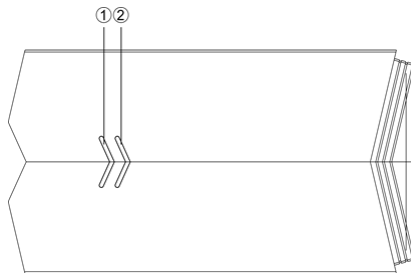

Serial No.	Name	Description
①	Power indicator	Red light on when the power supplied
②	Diagnostic indicator	Green light flashes when communicating with the vehicle

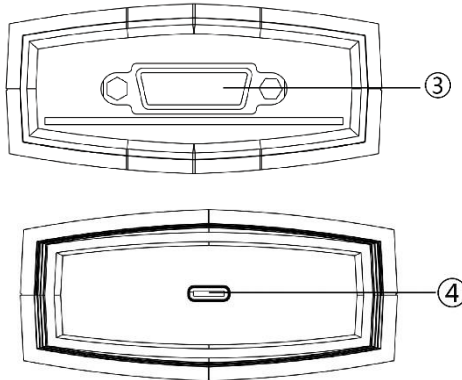

Serial No.	Name	Description
③	DB15 Interface	Connect with the main test line and connect the vehicle through the diagnostic connector
④	USB Type-C Interface	Connect with tablet host or upgrade FV100 for use

FV100 Main Parameter :

Processor	Cortex®-M3
Frequency	72MHZ
Bluetooth	V2.1+EDR, BT3.0, BT4.1
Memory	128KB

2 Host On/Off and Function Menu

2.1 Host Charging

Host can be charged in the following way:

Power adapter: Plug one end of the AC/DC power adapter to the DC power port of the host and then connect the other end to the wall socket. The power adapter can be

used to charge the built-in battery pack.

Note: Voltage of the power supply should be within the scope of the product host. Exceeding the range may cause damage to the product.

2.2 Booting

Press and hold the host power switch (about 3 seconds) to power on host, the following welcome interface will pop up, and then system starts working.



2.3 Shutdown

All vehicle communication must be terminated before shutting down the diagnostic equipment. Vehicle's electronic control module would go wrong if forced shutdown during communication, please exit all diagnostic applications before shutting down.

The shutdown steps are as follows:

- 1) Short press the host power switch (about 2 seconds)
- 2) Click [Shutdown] in the pop-up prompt to close the host.

2.4 Introduction to Each Menu Option

After the system is powered on, enter the following main menu:

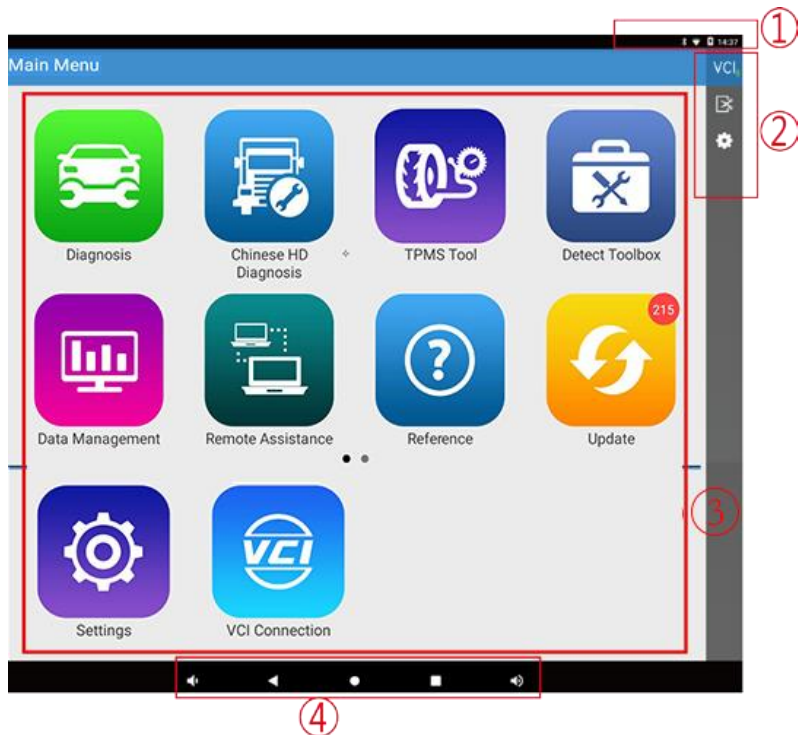

- 1) Status icon: is the default icon of the standard Android operating system
- 2) Toolbar (see Table 1 below)
- 3) Main menu (see Table 2 below)
- 4) Guide bar (see Table 3 below)

Tip: It is recommended to lock the screen whenever you are not using the device to protect your system information and save battery power. Slightly click the power/lock screen button once, the screen will be automatically locked. Excessive force or long press may cause the button to malfunction or enter the shutdown interface.

Table 1: Toolbar

Icon	Function name	Function description
	VCI Connection	VCI box connection and status display (always available throughout diagnostic operation)





	Screenshot	One click to capture the current visual screen (always available throughout the diagnostic operation)
	Settings	"Settings" function shortcut

Table 2: Main Menu

Icon	Function name	Function description
	Diagnosis	Vehicles diagnostic procedure
	Chinese HD Diagnosis	Chinese heavy diesel vehicles diagnosis procedure
	TPMS Tool	The application of the Fcar Tire Pressure Activation Tool device
	Detect Toolbox	Provide detecting tools
	Data management	Browse and manage data files stored
	Remote	Run this program to establish remote assistance with FCAR after-sales technical team
	Reference guide	Provide help information such as equipment usage instructions, maintenance assistance, trouble code inquiry, etc
	Update	Online upgrade of system software, model software, etc
	Settings	Set up and view system information







	VCI connection	Establish and manage communication connections with VCI devices
---	----------------	---

Table 3: Guide bar

Icon	Function name	Function description
	volume reduction	Turn down the tablet volume
	Back	Return to last interface
	Homepage	Return to the main interface of the Android system
	Recently used program	Display the list of recently-used program thumbnails list, click on the program thumbnail to open the program, and swipe up the program thumbnail to close the program
	Volume amplification	Turn up the tablet volume

3 Preparation before Diagnosis

Through having established data connection with the vehicle's electronic control system that has been connected to the VCI device, the diagnostic program can read vehicle diagnostic information, check the data stream, and perform actuation test and other functions.

- To establish good communication between the diagnostic program and the vehicle, you need to do as below:
 - 1) Connect the VCI box to the vehicle diagnostics socket and supply the power;
 - 2) Establish communication between the VCI box and the host via Bluetooth pairing or USB data cable;
 - 3) Check VCI connection status in the upper right corner of the screen (see 3.2.2).

The vehicle diagnosis can be performed after the connection.

- How to perform the Vehicle diagnosis
- 1) Establish a good communication between the diagnostic program and the vehicle under test, see 3.2
- 2) Select vehicle type, see 3.3.
- 3) Perform vehicle diagnosis by “Auto Scan” all systems of the vehicle or manually selecting and detecting a designated control unit. For details, see 3.5.

Here we make the detailed instructions.

3.1 Technical Requirements Before Diagnosis

3.1.1 Equipment Requirements

The device is equipped with a host and various test connectors when leaving factory. In testing, please select appropriate test connector according to the type of vehicle diagnosis socket.



3.1.2 Vehicle Requirements

- ◇ Turn ignition switch to gear ON;
- ◇ Vehicle battery voltage should be between 11~14V or 24~27V (subject to the vehicle's power supply)
- ◇ Accelerator pedal is in OFF state, that is, the idle coupling point;
- ◇ Ignition timing and idle speed value should be within the standard

range, and the water temperature and transmission oil temperature are in the normal working temperature (water temperature 90~110°C, transmission oil temperature 50~80°C);

- ◇ Then, diagnostic cable is connected properly.

3.1.3 Technician Request

- ◇ Must have a basic knowledge of automotive electronics;
- ◇ Understand the basic operation methods of this product and familiarize with this manual;
- ◇ Basically distinguish whether it is a mechanical fault or an electronic control fault from the vehicle fault phenomenon tested;
- ◇ Learn about the vehicle's origin, year of production, model, engine model and more.



3.2 Vehicle Connection

3.2.1 Connect VCI Box to Vehicle

Before VCI box connected to a vehicle, it is necessary to judge whether the diagnostic socket of the test vehicle is a standard OBD-II port or a non-standard OBD-II port.

- For vehicles with a standard OBD-II port: Connected the VCI to the vehicle

diagnostics socket directly.

- For vehicles with a non-standard OBD-II port: Need to add a corresponding connector to adapt the port; some other vehicles need to supply power to the VCI box through other power sources of the vehicle.

Standard OBD-II port connection:

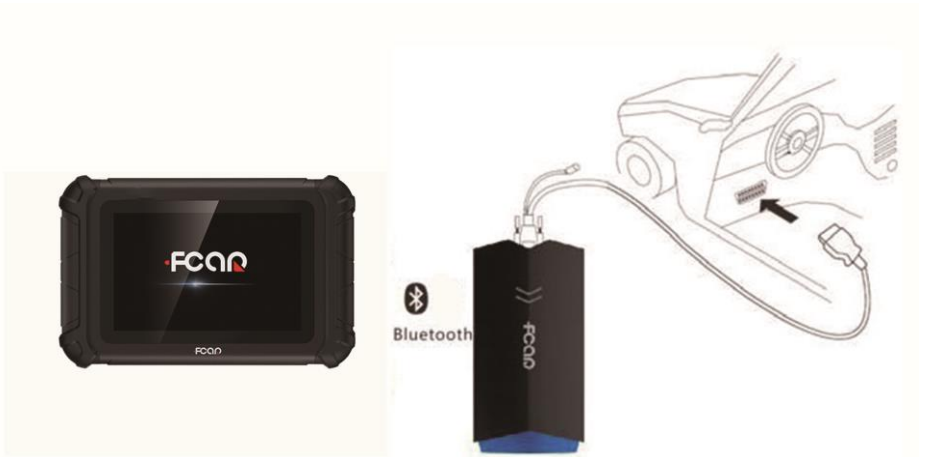

Instructions:

- 1) Determine the location and the port of the diagnostic socket;
- 2) Connect one end of main test cable to DB15 connector of the VCI box and fasten the fixing bolt;
- 3) Connect the other end of the main test cable to the vehicle diagnostic socket;
- 4) At this time, the VCI box is powered by the vehicle diagnostic socket, and the power indicator light is on.

Note: After test is completed, please rotate the fixing bolts and then gently unplug the main test cable to avoid damage to the diagnostic port.

NON-OBD-II PORT CONNECTION

For vehicles connected to non-OBD-II interfaces, need to connect the main test cable to their corresponding dedicated connectors, as shown in the figure below.



Instructions:

- 1) Determine the location, the port, and whether need to be connected to external power source of diagnostic socket;
- 2) Connect one end of the main test cable to the DB15 connector of the VCI box and lock the fixing bolts;
- 3) Connect the other end of the main test cable to a dedicated adaptor corresponding to the vehicle;
- 4) Connect the dedicated connector that is connected to the main test cable to the vehicle diagnostic socket;
- 5) At this time, VCI box is powered by the vehicle diagnostic socket, and then power indicator light is on (if it is not lit, it may be because the vehicle diagnostic socket is not energized, you can energize the VCI box by the cigarette lighter or the battery clip).



3.2.2 Host and VCI Box Connection

After VCI box is connected to the vehicle, the connection between the host and the VCI box needs to be matched, and then vehicle diagnosis can be started after matching is completed; the VCI box supports two ways of communicating with the

host: Bluetooth pairing and USB cable.

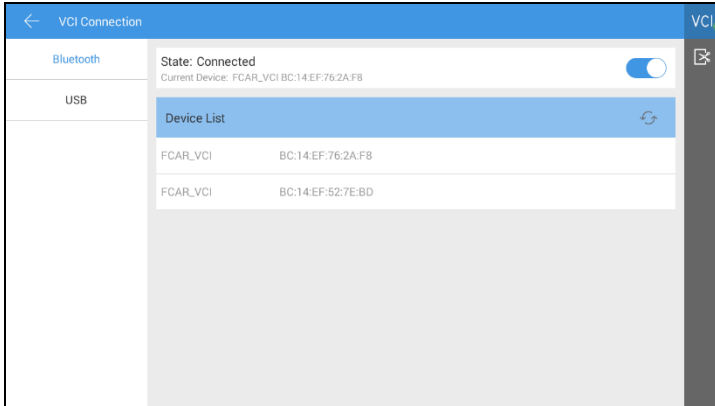
- **Paired through Bluetooth**





- 1) Turn on the host power supply;
- 2) Select [VCI Connection] in the main menu; select [Bluetooth] in the connection mode;
- 3) Click the Scan icon  on the right side of the device to automatically scan Bluetooth devices nearby.
- 4) Select target Bluetooth to match;
- 5) When matching is completed, state of VCI icon in the upper right corner of the screen changes from "" to "", indicating that the Bluetooth pairing is successful and the vehicle diagnosis can be started.

Note: If the signal strength of the transmitter is too weak, Bluetooth device can't be searched. In this case, please move it as close as possible to the VCI Bluetooth device.

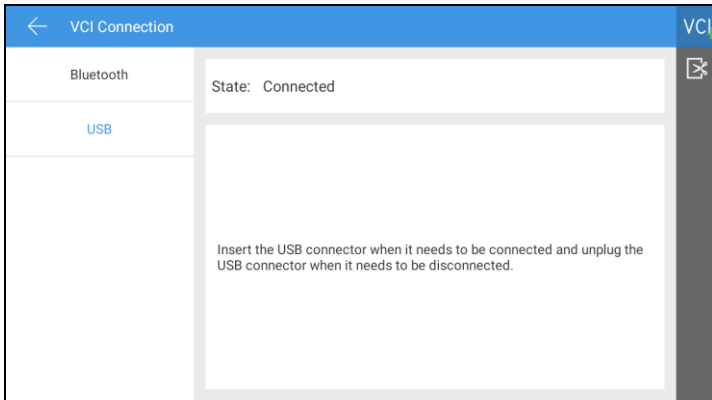
- **Through USB cable connection**



USB connection is the fastest communication method between the host and the VCI device. Please use dedicated USB cable configured by our factory to connect. After the connection is completed, state of VCI icon in the upper right corner of the screen changes from “” to “”, indicating that the USB connection is successful, and then the vehicle diagnosis can be started.

Note: These two connection methods can't be used at the same time!

3.3 Vehicle Models Selection



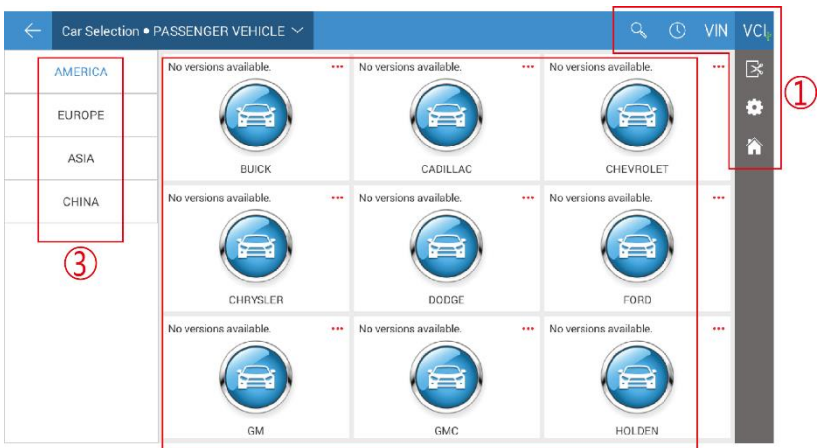

When all the above connections are completed, click [Diagnosis] on Main Menu to start the vehicle diagnosis. The following figure shows the gasoline version of the vehicle selection interface. The other versions of the model interface are similar.



②

- 1) Toolbar (see Table 1 below)
- 2) Regards to model manufacturer and related detection functions, click on “ ● ● ● ” in upper right corner of the model to view function list and other related information of the vehicle type.
- 3) Asian, European, American major brand vehicle series selection menu

Table 1:

Icon	Name	Function description
	Search	One-click search for major brand vehicle types
	History record	View maintenance history, quick access to diagnostics, view diagnostic List, model version information, and more
	VIN code	Identify the vehicle types by manually or automatically scanning the VIN code
	Homepage	Return to Main Menu

Diagnostic program requires “Car Selection” before entering the system module diagnostic function. The device can do vehicle identification in the following ways:

- 1) Manual selection
- 2) "Auto Selection" function
- 3) Direct access to the vehicle system module
- 4) Automatically scan VIN code
- 5) Manually input VIN code
- 6) Access via OBD

3.3.1 Manual Selection

Manual Vehicle Selection uses menu guide mode, just follow the on-screen instructions to make a series of selections, and then specific options will vary depending on the model being tested. Among a large number of vehicle types, you can even quickly find the target brand through search function of the toolbar, and then select according to the screen prompts; for gasoline models, you can find the

brand according to the location of the model (i.e. Chinese, Asian, European, American), then select according to the screen prompts until accurately identify the vehicle to be tested.

3.3.2 Automatic Identification

The latest automatic identification function of FCAR smart diagnostic system can skip Manual Vehicle Selection, to obtain specific vehicle information directly from the vehicle ECU, and quickly enter the diagnostic interface after confirmation. At present, this function supports a part models, subject to the menu displayed. The following is an example of Lincoln:

- 1) Select [LINCOLN] of AMERICA from the vehicle selection interface;
- 2) Click [Auto Vehicle Selection] from the vehicle selection, then the diagnostic program will automatically recognize vehicle information;
- 3) Check the vehicle information carefully and click [OK] to enter the vehicle diagnosis interface directly.

3.3.3 Direct Access to Vehicle System

If clearly know the cause of the vehicle failure, you only need to enter specific system module. Currently the supported vehicle electronic control system includes engine system, anti-lock brake system, and SRS system. Here we take Bosch M797 engine system as an example:

- 1) Select [ENGINE SYSTEM] under CHINA menu in the vehicle selection interface;
- 2) Select [Bosch] in the engine electronic control system interface;
- 3) In the Bosch engine interface [Bosch M797 engine system], the system will automatically enter the function diagnosis interface.

3.3.4 Automatic Scan VIN Code

Automatic-scanning VIN code of FCAR smart diagnostic system can identify all CAN-compatible vehicles. With function of automatic VIN code scanning, service technicians can quickly find the target vehicle type. The operation steps are as follows:

- 1) Click [VIN] function icon on [Car Selection] and select [AUTO];
- 2) Click [Start Scan], then the diagnostic instrument starts to scan the VIN code

on the ECU;

- 3) Once the vehicle is successfully identified, the system will guide you to enter into the vehicle diagnostic interface.

3.3.5 Manual Input VIN Code

For models that do not support automatic scanning of VIN codes, FCAR Diagnostic System also supports manual input of VIN codes as below:

- 1) Click [VIN] function icon on Car Selection interface and select [MANUAL];
- 2) Enter correct VIN code in the input box, and click the search "  " icon on the right, the system will automatically display the searched model;
- 3) Once the vehicle is successfully identified, the system will guide you to enter into the vehicle diagnostic interface.

3.3.6 General OBD Access Mode

In some cases, database does not support or the vehicle has other functional features, so the diagnostic instrument cannot identify the vehicle and establish communication through the normal channel. At this time, OBDII or DIESEL OBD test can be started through the OBD direct access function. For details, see 3.7.

3.4 Diagnosis and Other High-Level Function

After the vehicle selection is completed, the vehicle diagnosis can be started.

Following is the operation method for the diagnosis of the gasoline models. Diagnosis methods of other models are similar. Here we check main interface of the gasoline version diagnosis:

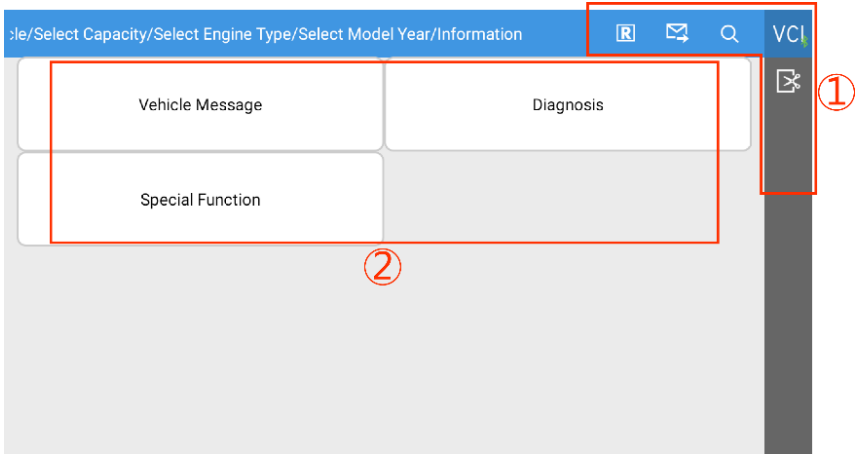

- 1) Toolbar and status bar (see Table 1 below)
- 2) Diagnostic function main interface (see 3.4.1 for details)

Table 1:

Icon	Function description
	Create test reports, you can view, print, send test reports, etc. in 'Data Management'
	One-click feedback, you can feedback problems in the vehicle diagnosis process to FCAR after-sales technical team

3.4.1 Diagnostic Function Main Interface

The main interface of the diagnosis mainly displays the function options of the selected model. The interface options are slightly different depending on the selected model.

The main function interface usually includes the following options:

- **Vehicle information:** Click to view the vehicle information to be tested, including: model, engine model, displacement, vehicle identification number, etc.
- **Diagnosis:** It can diagnose the vehicle's electronic control system, including reading fault codes, clearing fault codes, reading live data, and actuation test.
- **Special function:** The selected models have different special functions and

the displayed function names are slightly different. This option may sometimes be displayed as special functions, service data, maintenance reset or other similar names.

3.5 Diagnosis

Select [**Diagnosis**] to enter the vehicle system module in two ways: **Auto Scan** and **Manual Selection**.

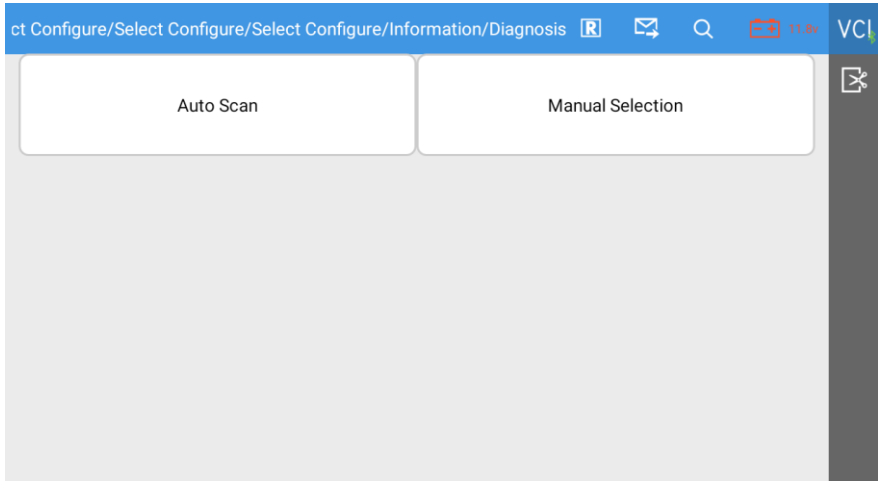

Auto Scan: Select this option, the diagnostic program will automatically scan all the systems of the vehicle under test, and support the reading of global fault codes, one-key clearing and other functions, the following figure is the automatic scanning interface:

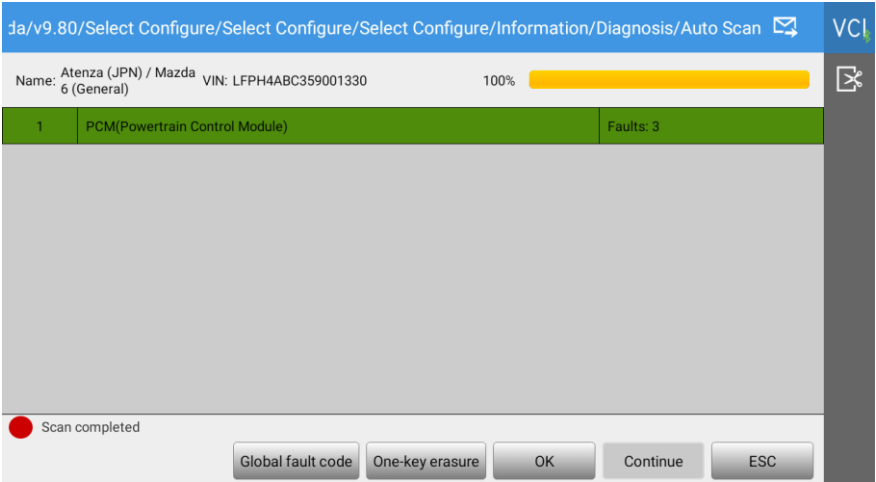

The following table is a functional button in automatic scanning:

Function name	Function description
Global fault code	Click to view vehicle full system fault code
One-key erasure	One-key erasure system all fault codes
OK	Select any system module, click OK to enter the module diagnostic interface.
Pause	Click Pause, the program will automatically pause the scan and display as [Continue]
ESC	Exit auto scan and return to the previous operation interface

Manual Selection: Select this option, the diagnostic program will display all vehicle control units, select a control unit, enter the diagnostic interface of the control unit, as shown below. (If the model is not configured, it cannot establish communication with the vehicle ECU)

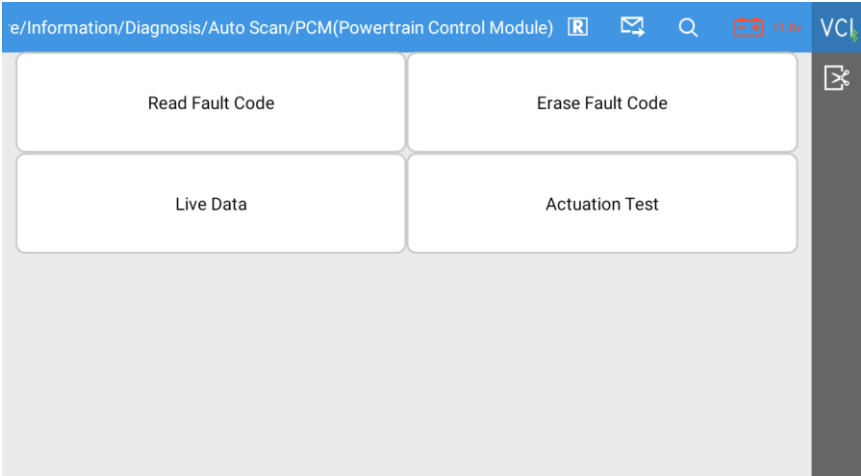

Read Fault Code: read and display DTC information retrieved from the vehicle system module

Erase Fault Code: clear the fault code and freeze frame data retrieved from the vehicle system module

Read Live Data: read and display the current system module real-time running parameters, this option may sometimes display as “real-time data”

Actuation Test: perform component testing for a specific subsystem

3.5.1 Read Fault Code

Read and display the fault code retrieved from the vehicle system module under test and explain the fault content, as shown in the following figure.

RD/v9.72/Information/Diagnosis/Auto Scan/PCM(Powertrain Control Module)/Read Fault Code			VCI
Code	Description	State	
P0102:03-04	Mass or Volume Air Flow Circuit Low Input	CMDTCs(More information...)	

3.5.2 Erase Fault Code

Before clearing the fault code for later viewing and comparison, please record and store the read fault code that you read.

➤ How to erase fault code

- 1) Select [Erase fault code] on the control module diagnosis interface;
- 2) At this time, the diagnostic system will pop up the prompts “Turn off the engine and turn on the ignition switch”, “The fault code and freeze frame data will be cleared, do you want to continue?”, select [Continue]; (Note: This step requires you to strictly operate the vehicle in accordance with the menu prompts)
- 3) When another prompt message pops up, select [Return] and re-execute the read fault code function to verify whether the fault code has been cleared.

➤ Fault code analysis steps

- 1) Read and record all fault codes;
- 2) Erase all fault codes;
- 3) Simulate the conditions generated by the fault and start a road test;

- 4) Then read and record the fault code at this time;
- 5) Distinguish between incidental fault codes (independent fault codes or historical fault codes) and persistent fault codes (current fault codes or associated fault codes);
- 6) Distinguish between the major fault code and the minor fault code associated with the fault symptom;
- 7) Distinguish the major fault codes in many fault codes or related fault codes (it may be the cause of other fault codes);
- 8) According to the above analysis, you can further detect the sensor represented by fault code, related circuit state of the actuator or control computer, as well as accurate position of the fault occurred.

3.5.3 Read Live Data

Select this function, the real-time operating parameters of the selected system module will be displayed on the screen. Different models or control modules have different data parameters, as shown in the figure below.

ID	Name	Current values	Unit
7	Air Conditioning Compressor Commanded State	Off	
8	A/C pressure sensor	30464.00	KPa
9	A/C pressure sensor	29.75	V
10	Air Conditioning Refrigerant Pressure Sensor A Voltage	29.75	V
11	A/C pressure sensor	30464.00	KPa
12	Air Conditioning Request Signal	Yes	
13	Air Flow Rate From Mass Air Flow Sensor Bank 1	3046.4	g/s
14	Accelerator Pedal Position	59.50	%
15	Accelerator Pedal Position D	46.67	%
16	Accelerator pedal position sensor 1	29.75	
17	Accelerator Pedal Position E	46.67	%

- ① Toolbar, see Table 1 below

- ② Live data display area
- ③ Hidden column, see Table 2 below

Table 1







Function icon	Function description
	Record data stream
	Select menu

Table 2

Function icon	Function description
	Function hiding icon
	Data stream waveform
	Data stream comparison

Data stream waveform

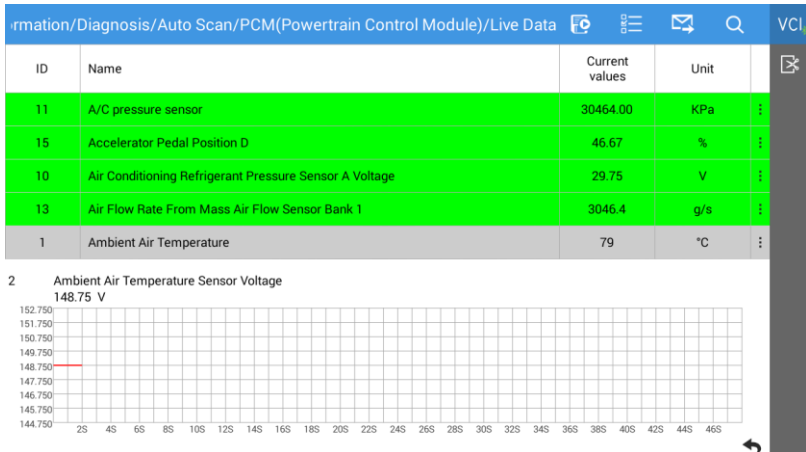

In data flow interface, click any numerical parameter item in the hidden column, select [Data Flow Waveform] function icon "", you can view the data flow waveform of the running parameter. Select lower right corner "" to return to the value display state.



Data stream recording and comparison function



FCAR smart diagnosis system supports the recording and saving of data stream, and it can be viewed infinitely in [Data Review]. It also supports the comparison function of data streams. When the vehicle is in good condition, the data stream can be collected and stored so as to provide a data reference through the data stream comparison function for the next test or encountering a vehicle with the same model.

➤ How to record data stream

- 1) Click [Selection] function icon " " in the upper right corner, tick the parameter items to be recorded in the pop-up window, and select [OK] to return;
- 2) Select the [Data Stream Recording] function icon " ", enter the stored file name in the pop-up window (it is suggest that the file is named after the vehicle information for easy reference), select [OK] to return;
- 3) Click [OK] to start recording, manually slide the touch screen slowly to the last data column; click [Stop] button in the lower left corner to stop recording and automatically save the data stream;
- 4) After the data stream is recorded, the system will automatically store it (tip: the data stream can be stored for up to 2 minutes). The data stream stored can be

viewed from [Data Review] in the data management function.

➤ How to perform data stream comparison

- 1) Click [Selection] function icon "" in the upper right corner, tick the parameter items to be compared with data stream in the pop-up window, and select [OK] to return;
- 2) Click [Data Stream Contrast] function icon "" in any hidden column on the right side. In the pop-up dialog box, tick the data file that has stored with the same model and select [OK] to return.
- 3) At this time, a bar of "comparison value" is emerged in the data flow interface, as shown in the figure below, the service technician can quickly find and eliminate the vehicle fault problem through system parameter comparison.

Note: The function icons such as data stream waveform or line graph and data stream comparison of some models are displayed at the bottom position of the data stream interface. Please operate according to the specific vehicle function display menu.

ID	Name	CMPR values	Current values	Unit	
150	Transmission Park or Neutral Range Switch	Yes	Yes		⋮
151	Time Since Engine Start	507.44	507.44	m.s	⋮
152	Actual Exhaust B Camshaft Position Bank 1	1904.00	1904.00	*	⋮
153	Exhaust B Camshaft Position Duty Cycle Bank 1	92.97	92.97	%	⋮
154	Exhaust B Camshaft Desired Minus Actual Bank 1	1904.00	1904.00	*	⋮
155	Desired Exhaust B Camshaft Position Bank 1	1904.00	1904.00	*	⋮
156	Actual Intake A Camshaft Position Bank 1	1904.00	1904.00	*	⋮
157	Intake A Camshaft Position Duty Cycle Bank 1	92.97	92.97	%	⋮
158	Intake A Camshaft Desired Minus Actual Bank 1	1904.00	1904.00	*	⋮
159	Desired Intake A Camshaft Position Bank 1	1904.00	1904.00	*	⋮
160	Reference Voltage	29.75	29.75	V	⋮

3.5.4 Actuation Test

By performing this function, you can access the vehicle-specific subsystem and

perform component testing, when performing the actuation test, the diagnostic device inputs an instruction to the ECU to drive the actuator, and thereby determines whether the actuator of the vehicle electronic control system and its line are normal. Different control systems of different models have different test options. Please refer to the menu display.

The following is an example of the air conditioner compressor command state under Ford's PCM (Powertrain Control Module).

➤ **How to do actuation test**

- 1) Enter Ford PCM (Powertrain Control Module) diagnostic interface by select Auto Vehicle Selection or Manual Vehicle Selection;
- 2) Select [Actuation Test] on Diagnosis interface;
- 3) Test item selection [ACC_CMD (air conditioner compressor command status)];
- 4) Drive the air conditioner compressor operation through [Off] and [On] buttons. When an operation is successfully completed, the screen will display “Operation Successfully” or other similar prompt information, as shown in the following figure.
- 5) According to the implementation, test whether the working state of the air conditioner compressor is normal. Click [Back] to exit the test.

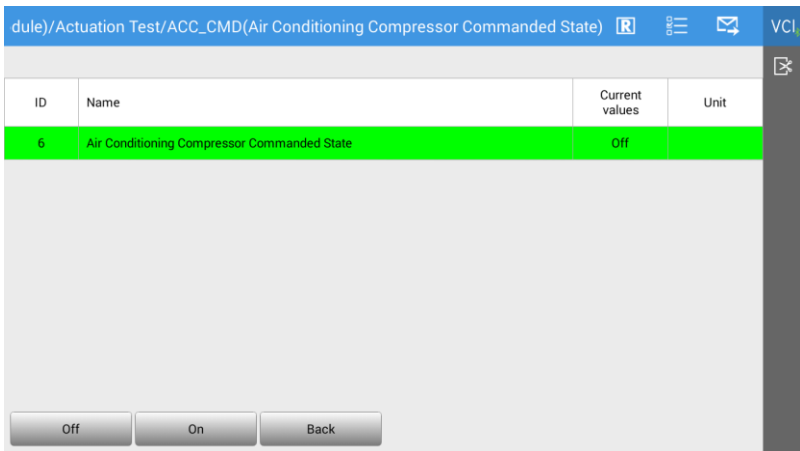

Note: The control buttons will be different according to the selected test item,

such as "On" "Off" or "+" "-".

With the “data customization” of some models of FCAR, you can also check the working status or values of other actuators and sensors associated with the component based on actuation test, helping the service technician to find the vehicle fault more accurately and quickly.

➤ **How to use data customization to do actuation test**

- 1) Enter Ford PCM (Powertrain Control Module) diagnostic interface by clicking Auto Vehicle Selection or Manual Vehicle Selection;
- 2) Select [Actuation Test] on diagnosis interface;
- 3) Select test item [ACC_CMD (air conditioner compressor command status)];
- 4) In ACC_CMD interface, click the menu “” and tick the data stream related to the status of the component in the pop-up window, and select [OK] to return;
- 5) At this time, several lines of data stream are automatically added under the “Air Conditioning Compressor Commanded State”, and the operation of the air conditioner compressor is driven with two buttons of [Off] and [On]. Test whether the working state of the air conditioner compressor is normal according to the execution status and the newly added data stream status.

ID	Name	Current values	Unit
6	Air Conditioning Compressor Commanded State	Off	
5	Air conditioning compressor cycling switch	Off	
8	A/C pressure sensor	30464.00	KPa
10	Air Conditioning Refrigerant Pressure Sensor A Voltage	29.75	V
12	Air Conditioning Request Signal	Yes	

3.6 Special Function

SPECIAL FUNCTION can do self-adapting for each component. It is mainly used to recalibrate or configure the components after repairing or replacing components, so that the components of the electronic control system can adapt to each other, otherwise the system will not operate normally.

Common special functions are: A/T reset, Battery match, Service reset, Throttle reset, EPB, TPMS, ABS Exhaust, CKP learning, ECU reset, Smart key program, SRS reset, DPF, SAS, Lamp adaption, Suspension, Windows, etc.

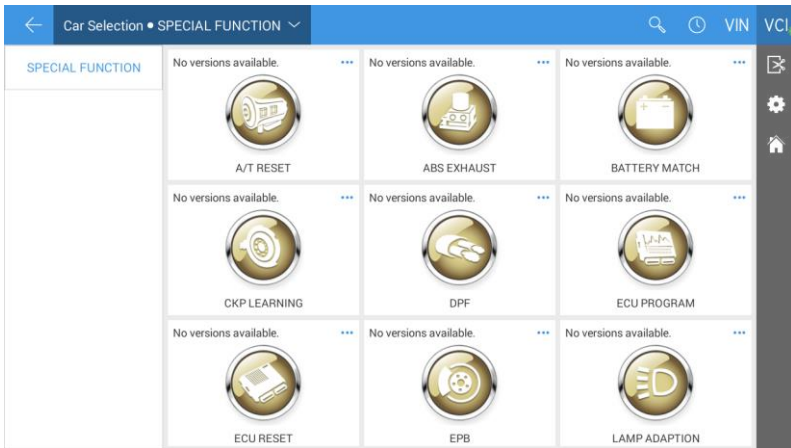

The main interface of the adaptive operation is under the menu guide mode. Please read the screen prompts carefully and operate according to the prompts. The specific selection of the procedure will vary depending on the model tested. Here we check the general processes of adaptive operation:

- 1) Select vehicle type and related configurations;
- 2) After the program establishes the normal communication with the vehicle ECU and some functional operations meet certain conditions, select the functional operation that needs to be performed.
- 3) Carefully read the information on the screen and check the corresponding vehicle status, strictly follow the menu prompts;

- 4) After the adaptive operation is completed, the screen will display prompts such as “Operation success” and “Match completely”.

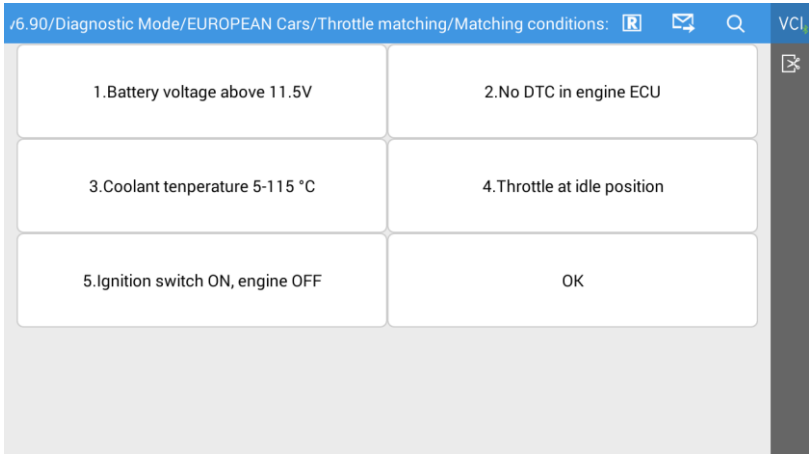



3.7 General OBDII

On the main menu of “Car Selection”, there is a quick access option for “OBDII” vehicle diagnosis. This option can be used to quickly check the fault code and find out the fault that enables the fault indicator to light up. Check monitor status before executing emission certification test, verify whether the service is successful, and do other emissions-related maintenance. The direct access option of OBD can also be used to test all OBDII/DIESEL OBD vehicles not included in the Diagnostic System database.

4 Chinese HD Diagnosis

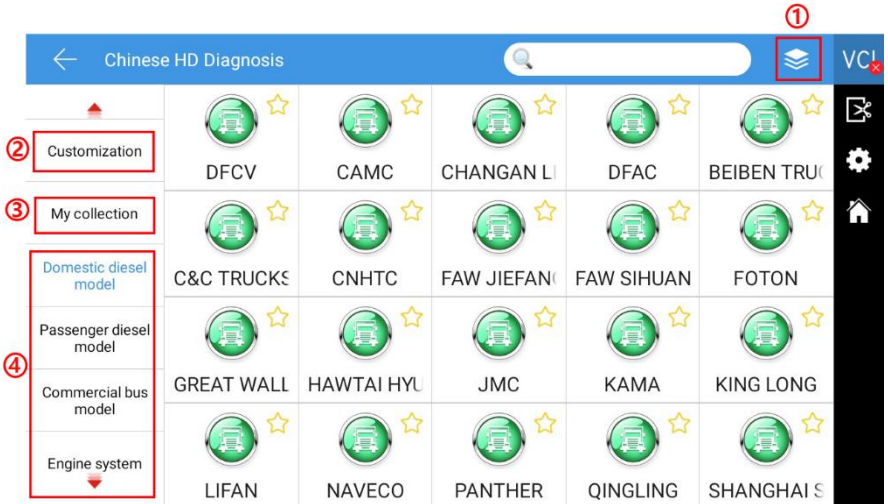
Chinese HD diagnosis is classified according to different origin, use and system. After the device is connected to the Chinese HD vehicle, Click the menu [Chinese HD Diagnosis] to enter the interface below.



- 1) Data package version upgrading records
- 2) Add common models for customization, and you can quickly enter the diagnosis interface of this model
- 3) Collection of common models (Press and hold the model icon, click  on the top right corner of the model to add the model functions to "My collection")
- 4) Vehicle type classification

5 Detect Toolbox

"Detect Toolbox" function provides two detecting tools: Node Screening and Pin Detecting. After you select [**Detect Toolbox**], you can see the interface as follows:

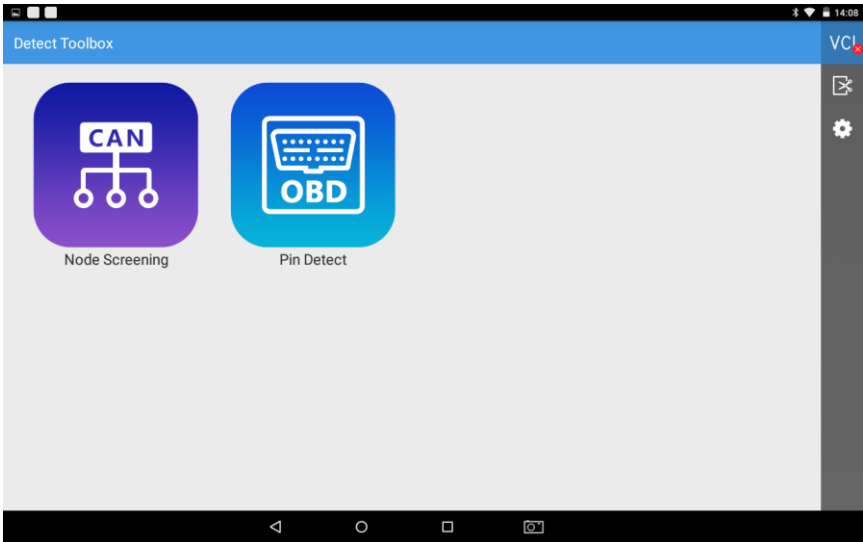

5.1 Node Screening

This function is used to screen all nodes which can normally communicate with ECU through CAN (Controller Area Network).

Note: This function is only provided to part of models of vehicles, you can contact FCAR for details.

“Node Screening” provides two searching ways.

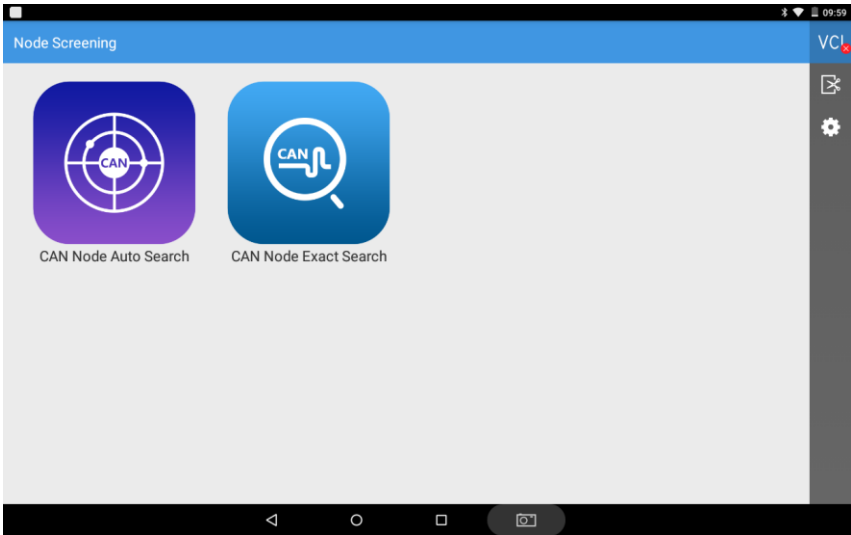

- CAN Node Auto Search: the program will automatically search and list all CAN nodes which can normally communicate with ECU.
- CAN Node Exact Search: the program will search and list some CAN nodes with normal communication according to the system or module that you select.

5.2 Pin Detecting

This function is used to measure the voltage of the 16 pins of the OBD interface and judge the pin position of the K line and the CAN line.

The interface is as shown below.

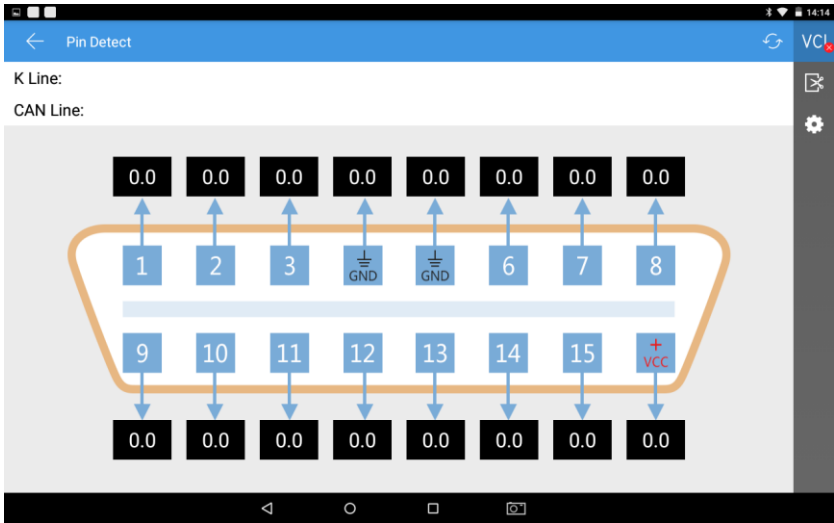

6 Data Management

"Data Management" application is used to save, view, or print saved files. Most of the files are generated by the toolbar operation of the vehicle diagnostics interface.

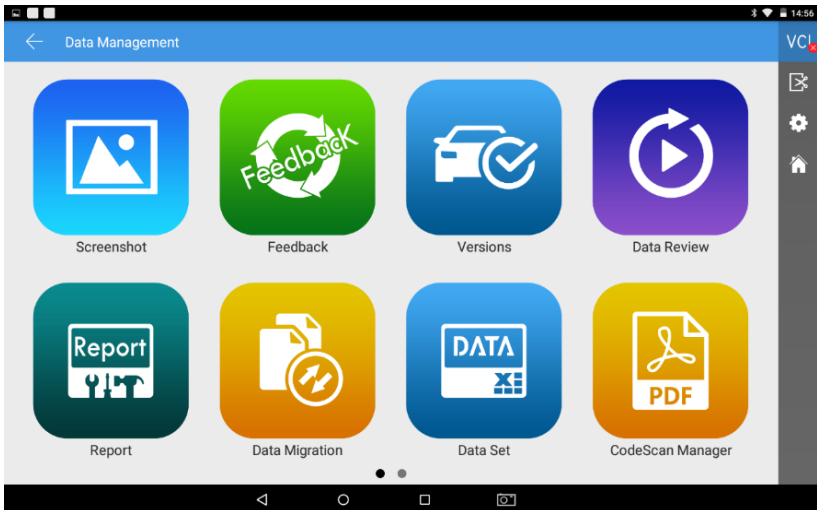

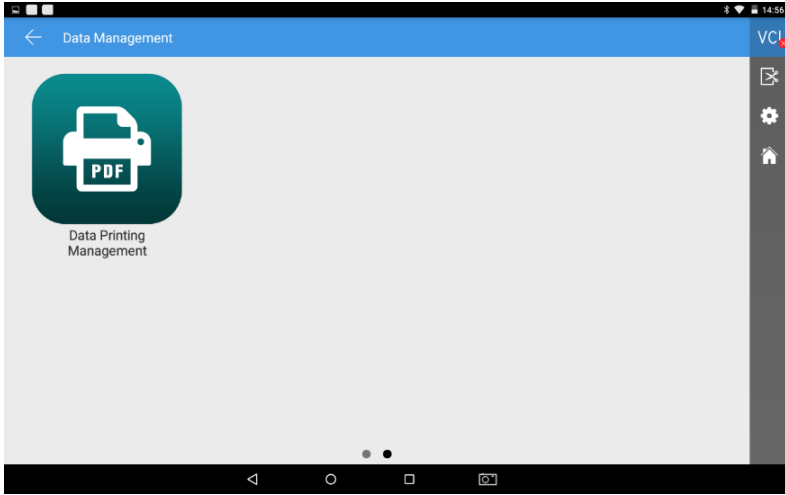

7 Remote Assistance

This function allows you to receive remote service and support from FCAR's after-sales technicians to assist you with vehicle diagnosis.

➤ How to receive technical support from FCAR

1. Turn on the host power supply;
2. Select [Remote] from Main Menu to enter Team Viewer interface, and then the system automatically generates and displays the device ID.
3. Send your device ID number to FCAR after-sales team and wait for them to send the remote control request to you;
4. After receiving the request, you can select [YES] to accept, or [NO] to reject in the pop-up window.

Note: Make sure the device is connected to the Internet before receiving remote assistance.

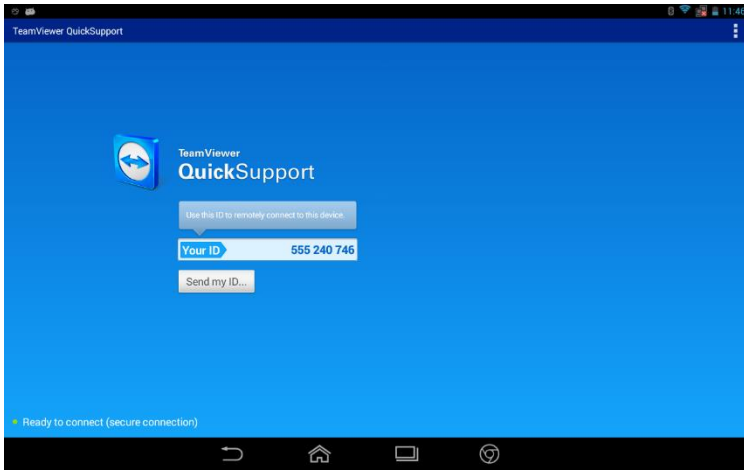

8 Reference

Here we have built in product manual, Fault Code inquiry, dictionary and other maintenance information for the user to access.

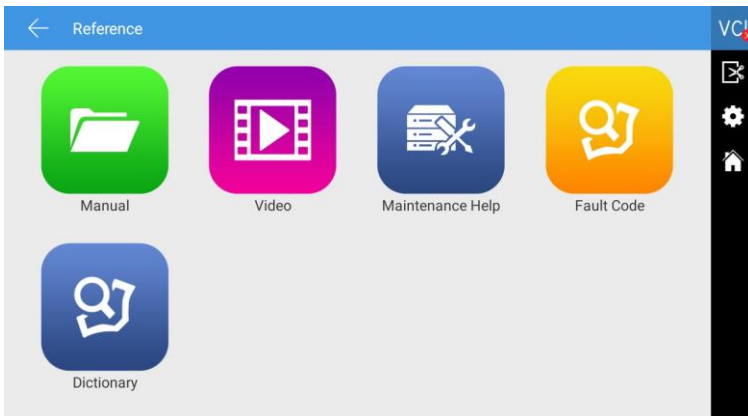

9 Update

Connect the device to the Internet to upgrade the diagnostic software and improve product functionality in a timely manner. Enter [Update] from Main Menu, then the system will automatically search for the latest update program, as shown below, click

[Update] to update vehicle types and other applications to the latest version.

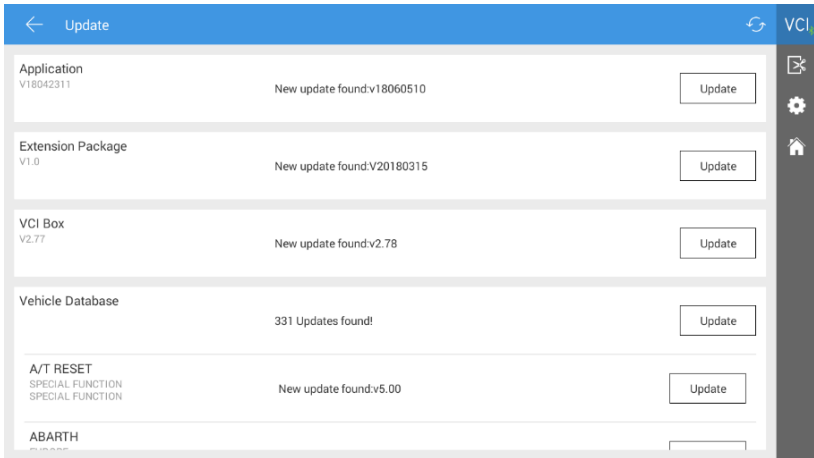

10 Setting

In the main menu, click **[Settings]** to enter the setting interface.

10.1 Language

The fault diagnostic equipment is available in multiple languages setting, please set according to the language supported by the model you purchased.

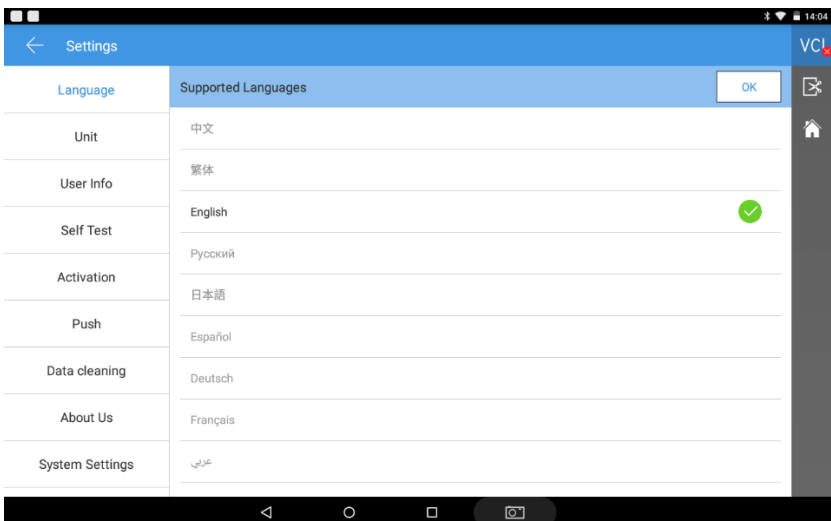

10.2 Unit

This option allows you to set the live data unit in the diagnostic software, please select metric or British as needed.

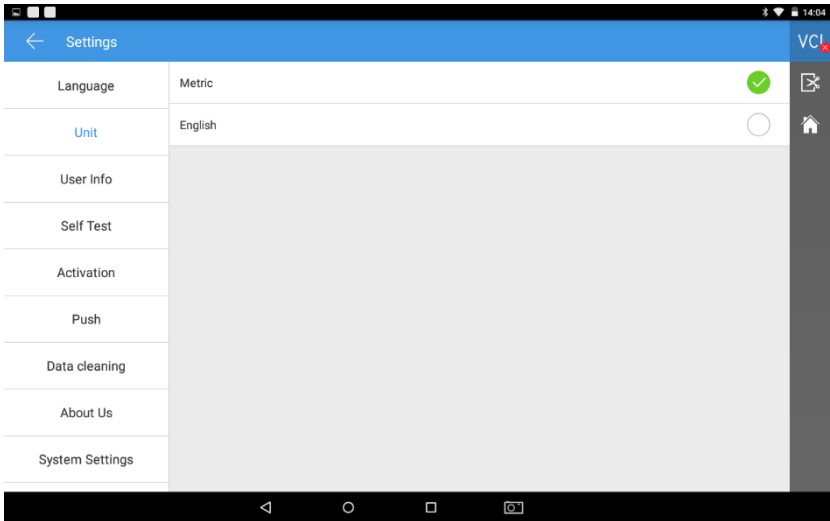

10.3 User Info

Set your personal information: Name, Telephone, Email, Address, etc.

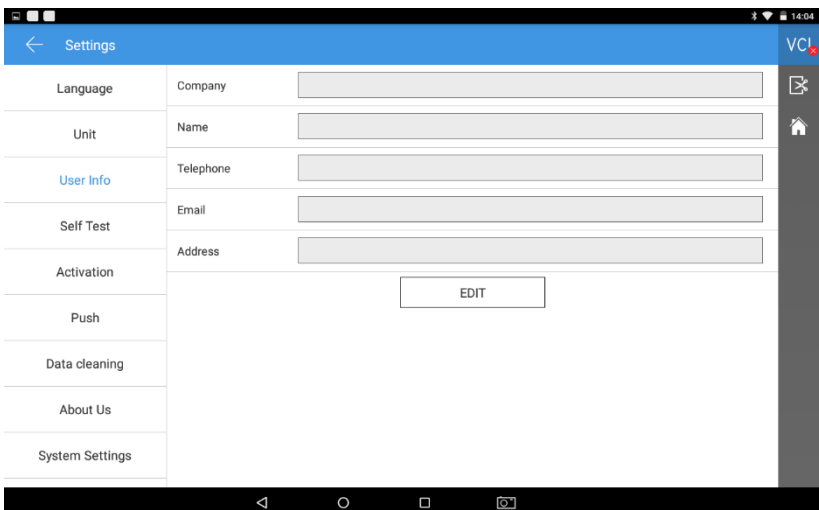

10.4 Self Test

Connect the device according to the screen icon, and click [Start Test] to check the open circuit and short circuit of the main test cable and OBD-II connector to judge whether it is good or bad.

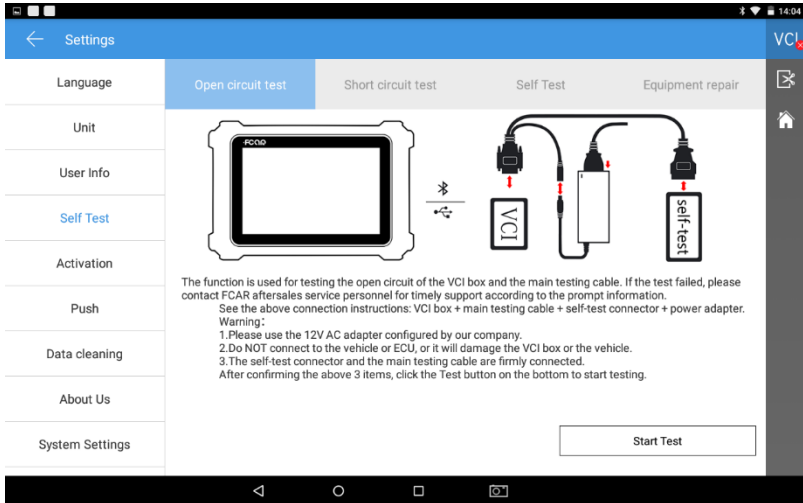

10.5 Activation

The product is shipped with a time-limited usage restriction. When you power on the machine, it will prompt: "You are using the trial version, there is ** chances left to use", connect Internet and click [Activation] to activate the machine.

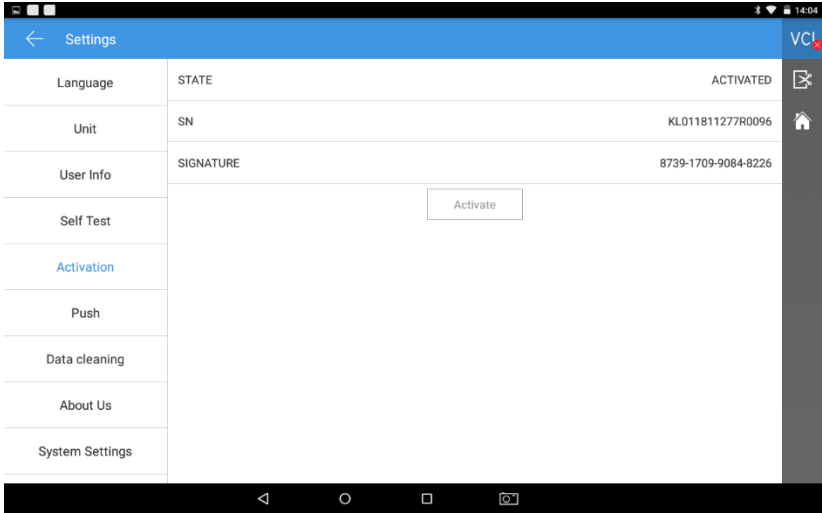

10.6 Push

With "Push" function, the host can receive periodic online messages from the server, such as system update notifications or other service message notifications. It is recommended that you always turn this function on so that you can receive the latest update service in a timely manner.

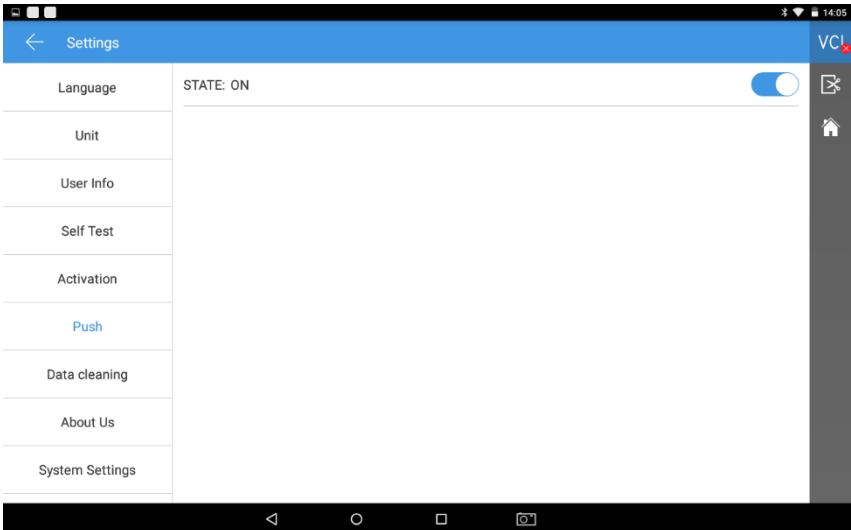

10.7 Data Cleaning

This function is used to clean the useless data packets, and release more storage space.

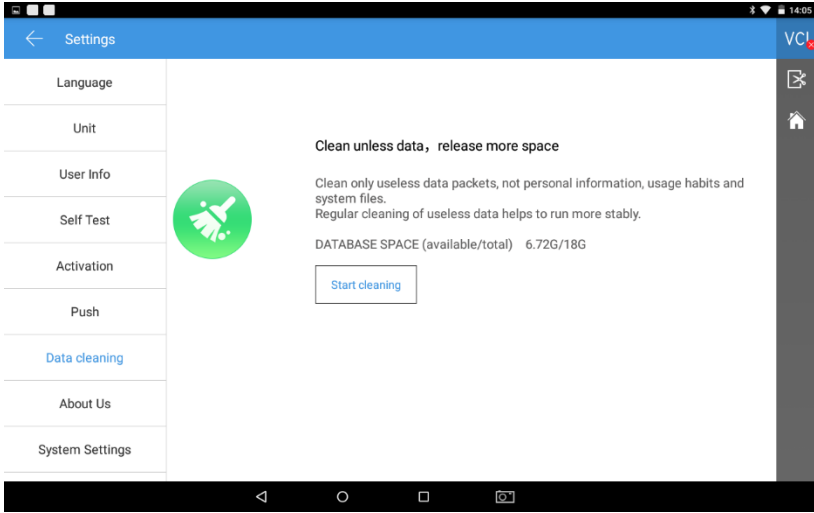

10.8 About Us

This interface shows system information, activation state, storage, etc.

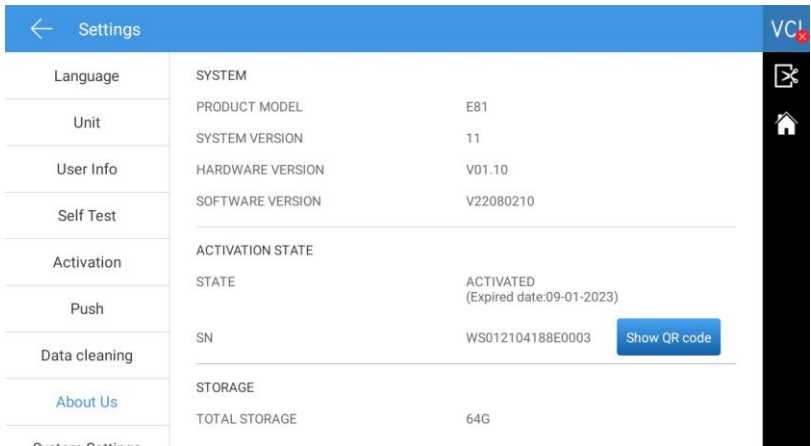

10.9 System Setting

You can set the Android system basic information.

Warranty

Dear FCAR users, you are welcome to choose the FCAR series. In order to better use the product, we recommend that you take care of your product and follow the instructions of the user's instructions every time you use it. If your use meets this requirement, you will have the product you will have. Longer-term quality service.

1. In accordance with the following terms and conditions, and you have passed the machine activation or user registration, if the product has defects in materials or processes, Shenzhen FCAR Technology Co., Ltd. (hereinafter referred to as "FCAR Technology") will provide products warranty service.

2. Your product must be purchased through a product dealer authorized by FCAR Technology. If you purchase the product through an abnormal channel, the purchaser must bear the cost of the product repair service.

3. The following items of the product: product use instructions, internal and external packaging boxes, promotional gifts and other consumable items are not covered by the warranty.

4. The product shall be purchased from the date of purchase (subject to the valid purchase certificate and valid warranty card of this product). If the product has performance failure caused by non-human damage, you may choose to repair the product or replace the same model within one month. Free warranty for mainframe, main test leads, connectors, and power adapters within one year.

5. In any of the following cases, your product will not be covered by the free warranty service:

1) Faults, defects or defects caused by the quality of non-FCAR technology products: including improper use of the product according to the product manual, improper operation of the product, impact, drop, self-assembly, improper connection of accessories, transport or storage of the product Improper, resulting in erosion, rust, etc. caused by pressure loss, penetration of liquid or food;

2) Natural wear and tear of the product: including but not limited to housing, buttons, touch screen, accessories, etc.;

3) Product host serial number and warranty card product serial number do not match, product quality inspection label or barcode is removed, altered or damaged;

4) Disassembly and repair and modification without the approval of FCAR Technology.

6. If the product has quality problems or malfunctions during the warranty period, you can take the following measures:

1) You can self-test the product according to the product help information. If there is no hardware quality problem, you can try to upgrade the product;

2) You can call the FCAR Technology Customer Service Hotline (0086-755-82904730) for the correct service information;

3) After obtaining a valid reply from the company, you must send the product to the company's designated address for repair and maintenance, otherwise your product will not be repaired and maintained in time. If it happens, it will be at your own risk.

7. During the warranty service, you will bear the costs associated with the delivery of the product to or from the designated location of FCAR Technology: including packaging, transportation, transportation, insurance, etc.

8. The free warranty service you enjoy under this warranty is the only measure for the loss of the product during the warranty period. FCAR Technology is not responsible for any direct or indirect damages.

9. All warranty information, product features and specifications of the product will be announced on the latest promotional materials and website of FCAR Technology without prior notice.

Certification

This product has been strictly inspected as qualified products and met the company standards.

Product name	Automotive Diagnostic System
Product serial number	
Date of production	
Inspector	



Warranty card

Product name	Automotive Diagnostic System
Product serial number	
Purchase date	

Company name: _____

User address: _____

Contact person: _____

Contact number: _____



FCC Statement

This equipment has been tested and found to comply with the limits for a Class B digital device, pursuant to Part 15 of the FCC Rules. These limits are designed to provide reasonable protection against harmful interference in a residential installation. This equipment generates uses and can radiate radio frequency energy and, if not installed and used in accordance with the instructions, may cause harmful interference to radio communications. However, there is no guarantee that interference will not occur in a particular installation. If this equipment does cause harmful interference to radio or television reception, which can be determined by turning the equipment off and on, the user is encouraged to try to correct the interference by one or more of the following measures:

- Reorient or relocate the receiving antenna.
- Increase the separation between the equipment and receiver.
- Connect the equipment into an outlet on a circuit different from that to which the receiver is connected.
- Consult the dealer or an experienced radio/TV technician for help.

Changes or modifications not expressly approved by the party responsible for compliance could void the user's authority to operate the equipment.

This device complies with part 15 of the FCC Rules. Operation is subject to the following two conditions:

(1) This device may not cause harmful interference, and (2) this device must accept any interference received, including interference that may cause undesired operation.

Changes or modifications not expressly approved by the party responsible for compliance could void the user's authority to operate the equipment.

RF warning statement:

Body-worn operations are restricted to belt-clips, holsters or similar accessories that have no metallic component in the assembly and which provide at least 0 cm separation between the device and the users body.

SAR tests are conducted using

The radiated output power of this device is below the FCC radio frequency exposure limits. Nevertheless, the device should be used in such a manner that the potential for

human contact is minimized during normal operation.

The exposure standard for wireless devices employs a unit of measurement known as the Specific Absorption Rate, or SAR. The SAR limit set by the FCC is 1.6 W/Kg. Tests for SAR are conducted using standard operating positions accepted by the FCC with the device transmitting at its highest certified power level in all tested frequency bands. Although the SAR is determined at the highest certified power level, the actual SAR level of the device while operating can be well below the maximum value. This is because the device is designed to operate at multiple power levels so as to use only the power required to reach the network. In general, the closer you are to a wireless base station antenna, the lower the power output. To avoid the possibility of exceeding the FCC radio frequency exposure limits, human proximity to the antenna should be minimized.