



FCC Part 15C Test Report

FCC ID: 2AJC5SJ-10

Product Name:	Mini Speaker
Trademark:	N/A
Model Name :	SJ-10
Prepared For :	Shenzhen Sanjia Lixin Technology Co., LTD.
Address :	6/F,Building C,Furong Road,Gushu Village,Xixiang Town,Baoan District,Shenzhen, China
Prepared By :	Shenzhen BCTC Technology Co., Ltd.
Address :	No.101,Yousong Road,Longhua New District, Shenzhen,China
Test Date:	Jul. 24 – Jul. 31, 2016
Date of Report :	Aug. 1, 2016
Report No.:	BCTC-160709474E



TEST RESULT CERTIFICATION

Applicant's name : Shenzhen Sanjia Lixin Technology Co., LTD.
Address : 6/F,Building C,Furong Road,Gushu Village,Xixiang Town,Baoan District,Shenzhen, China
Manufacturer's Name..... : Shenzhen Sanjia Lixin Technology Co., LTD.
Address : 6/F,Building C,Furong Road,Gushu Village,Xixiang Town,Baoan District,Shenzhen, China

Product description

Product name : Mini Speaker
Model and/or type reference : SJ-10

Standards : FCC Part15.249
 ANSI C63.10-2013

This device described above has been tested by BCTC, and the test results show that the equipment under test (EUT) is in compliance with the FCC requirements. And it is applicable only to the tested sample identified in the report.

This report shall not be reproduced except in full, without the written approval of BCTC, this document may be altered or revised by BCTC, personal only, and shall be noted in the revision of the document.

Testing Engineer : _____
 Sky Huang

Reviewer (Supervisor) : _____
 Jade Yang

Approved & Authorized Signer(Manager): _____
 Carson Zhang



**Table of Contents**

	Page
1 . SUMMARY OF TEST RESULTS	5
1.1 TEST FACILITY	5
1.2 MEASUREMENT UNCERTAINTY	5
2 . GENERAL INFORMATION	6
2.1 GENERAL DESCRIPTION OF EUT	6
2.2 DESCRIPTION OF TEST MODES	7
2.3 BLOCK DIGRAM SHOWING THE CONFIGURATION OF SYSTEM TESTED	8
2.4 DESCRIPTION OF SUPPORT UNITS(CONDUCTED MODE)	8
2.5 EQUIPMENTS LIST FOR ALL TEST ITEMS	9
3 . EMC EMISSION TEST	10
3.1 CONDUCTED EMISSION MEASUREMENT	10
3.1.1 POWER LINE CONDUCTED EMISSION LIMITS	10
3.1.2 TEST PROCEDURE	10
3.1.3 DEVIATION FROM TEST STANDARD	10
3.1.4 TEST SETUP	11
3.1.5 EUT OPERATING CONDITIONS	11
3.1.6 TEST RESULTS	11
3.2 RADIATED EMISSION MEASUREMENT	14
3.2.1 RADIATED EMISSION LIMITS	14
3.2.2 TEST PROCEDURE	15
3.2.3 DEVIATION FROM TEST STANDARD	15
3.2.4 TEST SETUP	15
3.2.5 EUT OPERATING CONDITIONS	16
3.2.6 TEST RESULTS (BETWEEN 9KHZ – 30 MHZ)	17
3.2.7 TEST RESULTS (BETWEEN 30MHZ – 1GHZ)	18
3.2.8 TEST RESULTS (1GHZ~25GHZ)	20
3.3 RADIATED BAND EMISSION MEASUREMENT	23
3.3.1 TEST REQUIREMENT:	23
3.3.2 TEST PROCEDURE	23
3.3.3 DEVIATION FROM TEST STANDARD	24
3.3.4 TEST SETUP	24
3.3.5 EUT OPERATING CONDITIONS	24
4 . BANDWIDTH TEST	28
4.1 APPLIED PROCEDURES / LIMIT	28



Table of Contents

	Page
4.1.1 TEST PROCEDURE	28
4.1.2 DEVIATION FROM STANDARD	28
4.1.3 TEST SETUP	28
4.1.4 EUT OPERATION CONDITIONS	28
4.1.5 TEST RESULTS	29
5 . ANTENNA REQUIREMENT	34
5.1 STANDARD REQUIREMENT	34
5.2 EUT ANTENNA	34
6 . TEST SEUUP PHOTO	35
7 . EUT PHOTO	37



1. SUMMARY OF TEST RESULTS

Test procedures according to the technical standards:

FCC Part15 (15.249) , Subpart C			
Standard Section	Test Item	Judgment	Remark
15.207	Conducted Emission	PASS	
15.249	Radiated Spurious Emission	PASS	
15.249	Bandwidth	PASS	
15.205	Band Edge Emission	PASS	
15.203	Antenna Requirement	PASS	

NOTE:

(1) "N/A" denotes test is not applicable in this Test Report

1.1 TEST FACILITY

Shenzhen BCTC Technology Co., Ltd.

Add. : No.101,Yousong Road,Longhua New District, Shenzhen,China

FCC Registered No.: 187086

1.2 MEASUREMENT UNCERTAINTY

The reported uncertainty of measurement $y \pm U$, where expended uncertainty U is based on a standard uncertainty multiplied by a coverage factor of $k=2$, providing a level of confidence of approximately **95** %.

No.	Item	Uncertainty
1	Conducted Emission Test	$\pm 1.38\text{dB}$
2	RF power,conducted	$\pm 0.16\text{dB}$
3	Spurious emissions,conducted	$\pm 0.21\text{dB}$
4	All emissions,radiated(<1G)	$\pm 4.68\text{dB}$
5	All emissions,radiated(>1G)	$\pm 4.89\text{dB}$
6	Temperature	$\pm 0.5^{\circ}\text{C}$
7	Humidity	$\pm 2\%$



2. GENERAL INFORMATION

2.1 GENERAL DESCRIPTION OF EUT

Equipment	Mini Speaker												
Trade Name	N/A												
Model Name	SJ-10												
Model Difference	The product's different for model name and outlook color.												
Product Description	<p>The EUT is a Mini Speaker</p> <table border="1"><tr><td>Operation Frequency:</td><td>2402~2480 MHz</td></tr><tr><td>Modulation Type:</td><td>GFSK, PI/4 DPSK, 8DPSK</td></tr><tr><td>Bit Rate of Transmitter</td><td>1/2/3Mbps</td></tr><tr><td>Number Of Channel</td><td>79 CH</td></tr><tr><td>Antenna type:</td><td>PCB antenna</td></tr><tr><td>Antenna Gain (dBi)</td><td>0dBi</td></tr></table> <p>Based on the application, features, or specification exhibited in User's Manual, the EUT is considered as an ITE/Computing Device. More details of EUT technical specification, please refer to the User's Manual.</p>	Operation Frequency:	2402~2480 MHz	Modulation Type:	GFSK, PI/4 DPSK, 8DPSK	Bit Rate of Transmitter	1/2/3Mbps	Number Of Channel	79 CH	Antenna type:	PCB antenna	Antenna Gain (dBi)	0dBi
Operation Frequency:	2402~2480 MHz												
Modulation Type:	GFSK, PI/4 DPSK, 8DPSK												
Bit Rate of Transmitter	1/2/3Mbps												
Number Of Channel	79 CH												
Antenna type:	PCB antenna												
Antenna Gain (dBi)	0dBi												
Channel List	Please refer to the Note 2.												
Power	DC 3.7V DC 5V from adapter												
hardware version	--												
Software version	--												
Serial number	--												
Connecting I/O Port(s)	Please refer to the User's Manual												

Note:

1. For a more detailed features description, please refer to the manufacturer's specifications or the User's Manual.



2.

Channel List					
Channel	Frequency (MHz)	Channel	Frequency (MHz)	Channel	Frequency (MHz)
00	2402	27	2429	54	2456
01	2403	28	2430	55	2457
02	2404	29	2431	56	2458
~	~	~	~	~	~
08	2410	35	2437	62	2464
09	2411	36	2438	63	2465
10	2412	37	2439	64	2466
11	2413	38	2440	65	2467
12	2414	39	2441	66	2468
13	2415	40	2442	67	2469
~	~	~	~	~	~
14	2416	41	2443	68	2470
22	2424	49	2451	76	2478
23	2425	50	2452	77	2479
24	2426	51	2453	78	2480
25	2427	52	2454		
26	2428	53	2455		

2.2 DESCRIPTION OF TEST MODES

To investigate the maximum EMI emission characteristics generates from EUT, the test system was pre-scanning tested base on the consideration of following EUT operation mode or test configuration mode which possible have effect on EMI emission level. Each of these EUT operation mode(s) or test configuration mode(s) mentioned above was evaluated respectively.

Pretest Mode	Description	
Mode 1	CH00	GFSK,PI/4 DPSK,8DPSK
Mode 2	CH39	
Mode 3	CH78	
Mode 4	Link Mode	
For Conducted & Radiated Emission		
Final Test Mode	Description	
Mode 1	CH00	GFSK,PI/4 DPSK,8DPSK
Mode 2	CH39	
Mode 3	CH78	
Mode 4	Link Mode	

Note:

- (1) The measurements are performed at the highest, middle, lowest available channels.
- (2) The measurements are performed at all Bit Rate of Transmitter, the worst data was reported



2.3 BLOCK DIGRAM SHOWING THE CONFIGURATION OF SYSTEM TESTED

Radiated Spurious Emission Test

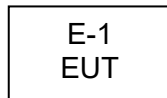

Conducted Spurious Emission Test



2.4 DESCRIPTION OF SUPPORT UNITS(CONDUCTED MODE)

The EUT has been tested as an independent unit together with other necessary accessories or support units. The following support units or accessories were used to form a representative test configuration during the tests.

Item	Equipment	Mfr/Brand	Model/Type No.	Series No.	Note
E-1	Mini Speaker	N/A	SJ-10	N/A	EUT
E-2	Adapter	BCTC	NBS05B050120VUU		

Item	Shielded Type	Ferrite Core	Length	Note

Note:

- (1) The support equipment was authorized by Declaration of Confirmation.
- (2) For detachable type I/O cable should be specified the length in cm in 『Length』 column.



2.5 EQUIPMENTS LIST FOR ALL TEST ITEMS

Radiation Test equipment

Item	Kind of Equipment	Manufacturer	Type No.	Serial No.	Last calibration	Calibrated until
1	Spectrum Analyzer	Agilent	E4407B	MY45109572	2015.08.25	2016.08.24
2	Test Receiver	R&S	ESPI	101396	2015.08.25	2016.08.24
3	Bilog Antenna	SCHWARZBECK	VULB9160	VULB9160-3369	2015.08.25	2016.08.24
4	50Ω Coaxial Switch	Anritsu	MP59B	6200264416	2015.08.25	2016.08.24
5	Spectrum Analyzer	Agilent	N9020A	MY5051041	2015.08.25	2016.08.24
6	Horn Antenna	SCHWARZBECK	9120D	9120D-1275	2015.08.25	2016.08.24
7	Horn Ant	Schwarzbeck	BBHA 9170	9170-181	2015.08.24	2016.08.23
8	Amplifier	SCHWARZBECK	BBV9718	9718-270	2015.08.24	2016.08.23
9	Amplifier	SCHWARZBECK	BBV9743	9743-119	2015.08.25	2016.08.24
10	Loop Antenna	ARA	PLSJ-1030/B	1029	2016.07.06	2017.07.05
11	Power Meter	R&S	NRVS	100696	2015.08.24	2016.08.23
12	Power Sensor	R&S	URV5-Z4	0395.1619.05	2015.08.24	2016.08.23
13	RF cables	R&S	N/A	N/A	2015.08.24	2016.08.23

Conduction Test equipment

Item	Kind of Equipment	Manufacturer	Type No.	Serial No.	Last calibration	Calibrated until
1	Test Receiver	R&S	ESCI	1166.5950K03-101165-ha	2015.08.25	2016.08.24
2	LISN	R&S	NSLK8126	8126466	2015.08.24	2016.08.23
3	LISN	R&S	NSLK8126	8126487	2015.08.24	2016.08.23
4	50Ω Coaxial Switch	Anritsu	MP59B	6200264417	2015.08.25	2016.08.24
5	RF cables	R&S	R204	R20X	2015.08.25	2016.08.24



3. EMC EMISSION TEST

3.1 CONDUCTED EMISSION MEASUREMENT

3.1.1 POWER LINE CONDUCTED EMISSION Limits (Frequency Range 150KHz-30MHz)

FREQUENCY (MHz)	Class A (dBuV)		Class B (dBuV)		Standard
	Quasi-peak	Average	Quasi-peak	Average	
0.15 -0.5	79.00	66.00	66 - 56 *	56 - 46 *	FCC
0.50 -5.0	73.00	60.00	56.00	46.00	FCC
5.0 -30.0	73.00	60.00	60.00	50.00	FCC

Note:

- (1) The tighter limit applies at the band edges.
- (2) The limit of " * " marked band means the limitation decreases linearly with the logarithm of the frequency in the range.

The following table is the setting of the receiver

Receiver Parameters	Setting
Attenuation	10 dB
Start Frequency	0.15 MHz
Stop Frequency	30 MHz
IF Bandwidth	9 kHz

3.1.2 TEST PROCEDURE

- a. The EUT was placed 0.8 meters from the horizontal ground plane with EUT being connected to the power mains through a line impedance stabilization network (LISN). All other support equipments powered from additional LISN(s). The LISN provide 50 Ohm/ 50uH of coupling impedance for the measuring instrument.
- b. Interconnecting cables that hang closer than 40 cm to the ground plane shall be folded back and forth in the center forming a bundle 30 to 40 cm long.
- c. I/O cables that are not connected to a peripheral shall be bundled in the center. The end of the cable may be terminated, if required, using the correct terminating impedance. The overall length shall not exceed 1 m.
- d. LISN at least 80 cm from nearest part of EUT chassis.
- e. For the actual test configuration, please refer to the related Item –EUT Test Photos.

3.1.3 DEVIATION FROM TEST STANDARD

No deviation

3.1.4 TEST SETUP

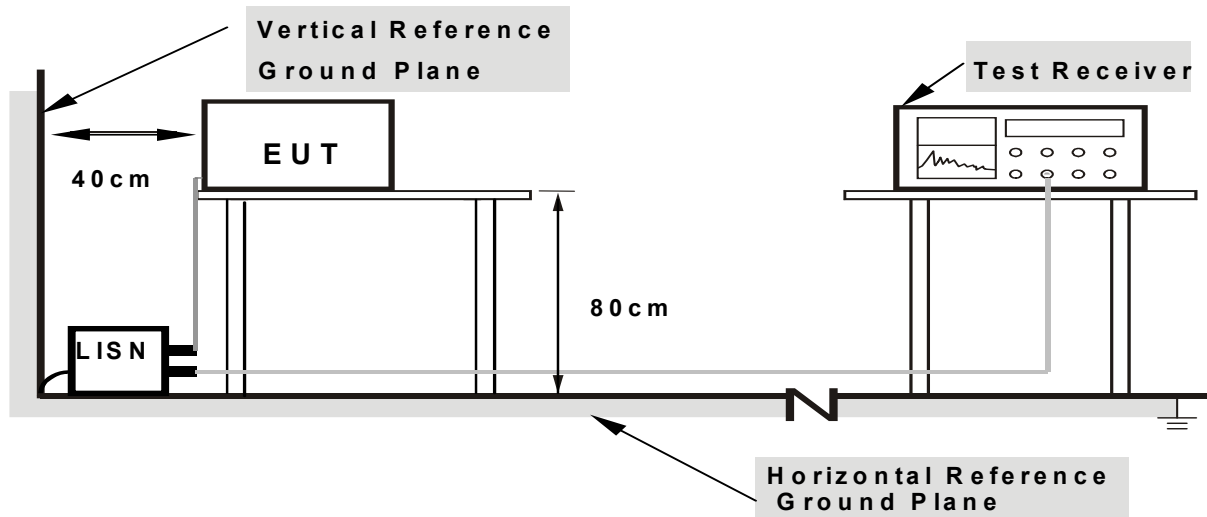

Note: 1.Support units were connected to second LISN.

2.Both of LISNs (AMN) are 80 cm from EUT and at least 80 cm from other units and other metal planes

3.1.5 EUT OPERATING CONDITIONS

The EUT was configured for testing in a typical fashion (as a customer would normally use it). The EUT has been programmed to continuously transmit during test. This operating condition was tested and used to collect the included data.

3.1.6 TEST RESULTS



Temperature :	25 °C	Relative Humidity :	54%
Pressure :	1010hPa	Phase :	L
Test Voltage :	AC 120V/60Hz	Test Mode :	Mode 4

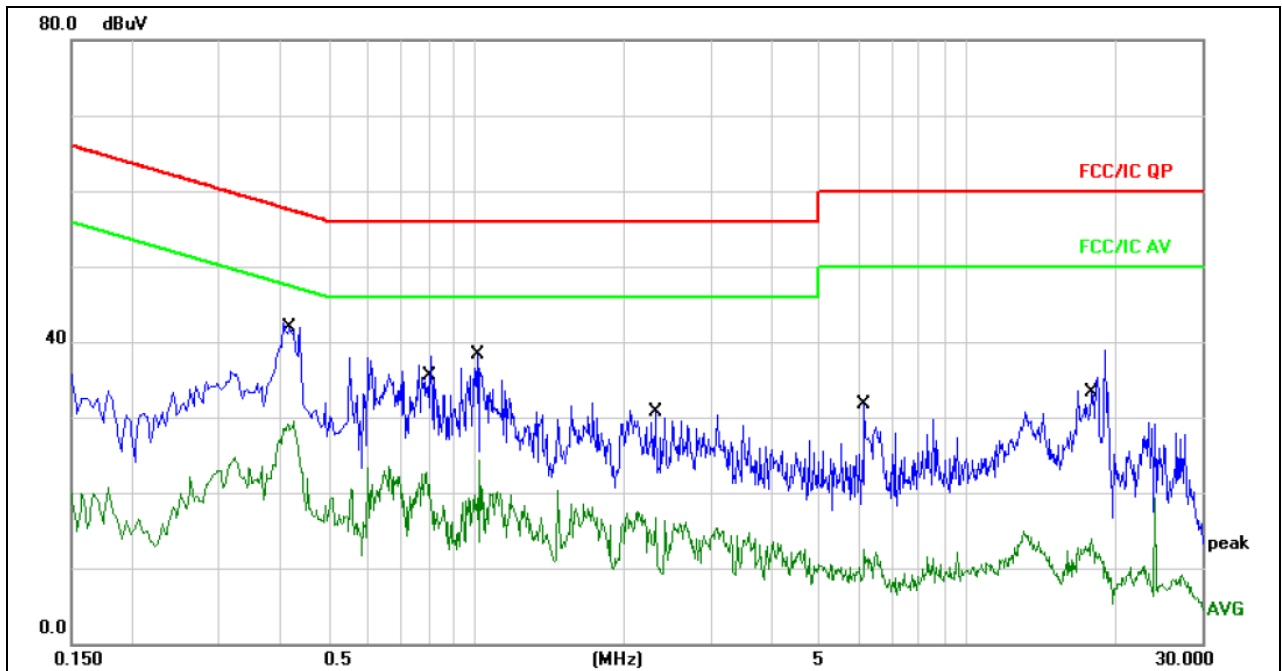

Remark:

1. All readings are Quasi-Peak and Average values.
2. Factor = Insertion Loss + Cable Loss.

No.	Mk.	Freq.	Reading Level	Correct Factor	Measurement	Limit	Over	Detector	Comment
		MHz	dBuV	dB	dBuV	dBuV	dB		
1	*	0.4180	31.81	10.11	41.92	57.49	-15.57	QP	
2		0.4180	19.44	10.11	29.55	47.49	-17.94	AVG	
3		0.7940	27.91	10.14	38.05	56.00	-17.95	QP	
4		0.7940	12.51	10.14	22.65	46.00	-23.35	AVG	
5		1.0100	28.05	10.17	38.22	56.00	-17.78	QP	
6		1.0100	14.04	10.17	24.21	46.00	-21.79	AVG	
7		2.3140	19.42	10.18	29.60	56.00	-26.40	QP	
8		2.3140	6.61	10.18	16.79	46.00	-29.21	AVG	
9		6.1579	21.52	10.09	31.61	60.00	-28.39	QP	
10		6.1579	2.51	10.09	12.60	50.00	-37.40	AVG	
11		17.9260	28.81	10.16	38.97	60.00	-21.03	QP	
12		17.9260	3.81	10.16	13.97	50.00	-36.03	AVG	



Temperature :	25 °C	Relative Humidity :	54%
Pressure :	1010hPa	Phase :	N
Test Voltage :	AC 120V/60Hz	Test Mode :	Mode 4

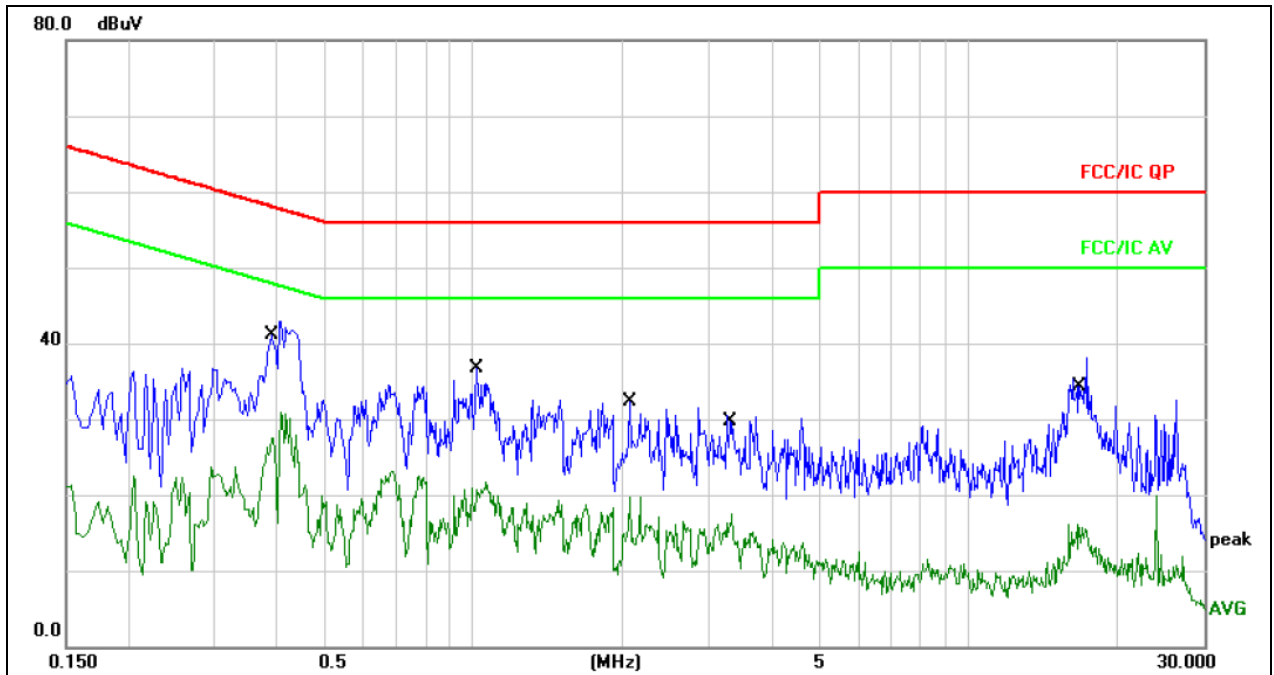

Remark:

1. All readings are Quasi-Peak and Average values.
2. Factor = Insertion Loss + Cable Loss.

No.	Mk.	Freq. MHz	Reading Level dBuV	Correct Factor dB	Measure- ment dBuV	Limit dBuV	Over dB	Detector	Comment
1		0.3860	29.13	10.10	39.23	58.15	-18.92	QP	
2	*	0.3860	20.86	10.10	30.96	48.15	-17.19	AVG	
3		1.0140	26.63	10.17	36.80	56.00	-19.20	QP	
4		1.0140	11.47	10.17	21.64	46.00	-24.36	AVG	
5		2.0660	22.12	10.18	32.30	56.00	-23.70	QP	
6		2.0660	9.49	10.18	19.67	46.00	-26.33	AVG	
7		3.3420	18.82	10.18	29.00	56.00	-27.00	QP	
8		3.3420	20.14	10.18	30.32	56.00	-25.68	QP	
9		3.3420	7.42	10.18	17.60	46.00	-28.40	AVG	
10		3.3420	1.38	10.18	11.56	46.00	-34.44	AVG	
11		16.6060	28.04	10.16	38.20	60.00	-21.80	QP	
12		16.6060	5.97	10.16	16.13	50.00	-33.87	AVG	



3.2 RADIATED EMISSION MEASUREMENT

3.2.1 RADIATED EMISSION LIMITS (Frequency Range 9kHz-1000MHz)

In case the emission fall within the restricted band specified on 15.205(a), then the 15.209(a) limit in the table below has to be followed.

Frequencies (MHz)	Field Strength (micorvolts/meter)	Measurement Distance (meters)
0.009~0.490	2400/F(KHz)	300
0.490~1.705	24000/F(KHz)	30
1.705~30.0	30	30
30~88	100	3
88~216	150	3
216~960	200	3
Above 960	500	3

LIMITS OF RADIATED EMISSION MEASUREMENT (Above 1000MHz)

FREQUENCY (MHz)	Class B (dBuV/m) (at 3M)	
	PEAK	AVERAGE
Above 1000	74	54

Notes:

- (1) The limit for radiated test was performed according to FCC PART 15C.
- (2) The tighter limit applies at the band edges.
- (3) Emission level (dBuV/m)=20log Emission level (uV/m).

Spectrum Parameter	Setting
Attenuation	Auto
Start Frequency	1000 MHz
Stop Frequency	25GHz
RB / VB (emission in restricted band)	1 MHz / 1 MHz for Peak, 1 MHz / 10Hz for Average

Receiver Parameter	Setting
Attenuation	Auto
Start ~ Stop Frequency	9kHz~150kHz / RB 200Hz for QP
Start ~ Stop Frequency	150kHz~30MHz / RB 9kHz for QP
Start ~ Stop Frequency	30MHz~1000MHz / RB 120kHz for QP

3.2.2 TEST PROCEDURE

Below 1GHz test procedure as below:

- The EUT was placed on the top of a rotating table 0.8 meters above the ground at a 3 meter semi-anechoic chamber. The table was rotated 360 degrees to determine the position of the highest radiation.
- The EUT was set 3 meters away from the interference-receiving antenna, which was mounted on the top of a variable-height antenna tower.
- The antenna height is varied from one meter to four meters above the ground to determine the maximum value of the field strength. Both horizontal and vertical polarizations of the antenna are set to make the measurement.
- For each suspected emission, the EUT was arranged to its worst case and then the antenna was tuned to heights from 1 meter to 4 meters (for the test frequency of below 30MHz, the antenna was tuned to heights 1 meter) and the rotatable table was turned from 0 degrees to 360 degrees to find the maximum reading.
- The test-receiver system was set to Peak Detect Function and Specified Bandwidth with Maximum Hold Mode.
- If the emission level of the EUT in peak mode was 10dB lower than the limit specified, then testing could be stopped and the peak values of the EUT would be reported. Otherwise the emissions that did not have 10dB margin would be re-tested one by one using peak, quasi-peak or average method as specified and then reported in a data sheet.

Above 1GHz test procedure as below:

- Different between above is the test site, change from Semi-Anechoic Chamber to fully Anechoic Chamber and change from table 0.8 metre to 1.5 metre (Above 18GHz the distance is 1 meter and table is 1.5 metre).
- Test the EUT in the lowest channel, the middle channel, the Highest channel

Note:

Both horizontal and vertical antenna polarities were tested and performed pretest to three orthogonal axis. The worst case emissions were reported

3.2.3 DEVIATION FROM TEST STANDARD

No deviation

3.2.4 TEST SETUP

(A) Radiated Emission Test-Up Frequency Below 30MHz

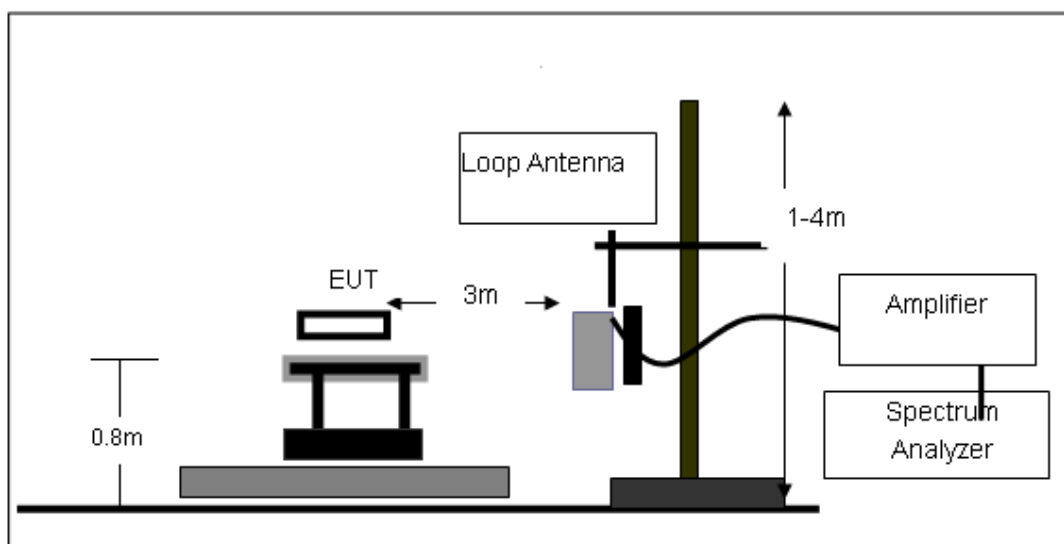

(B) Radiated Emission Test-Up Frequency 30MHz~1GHz

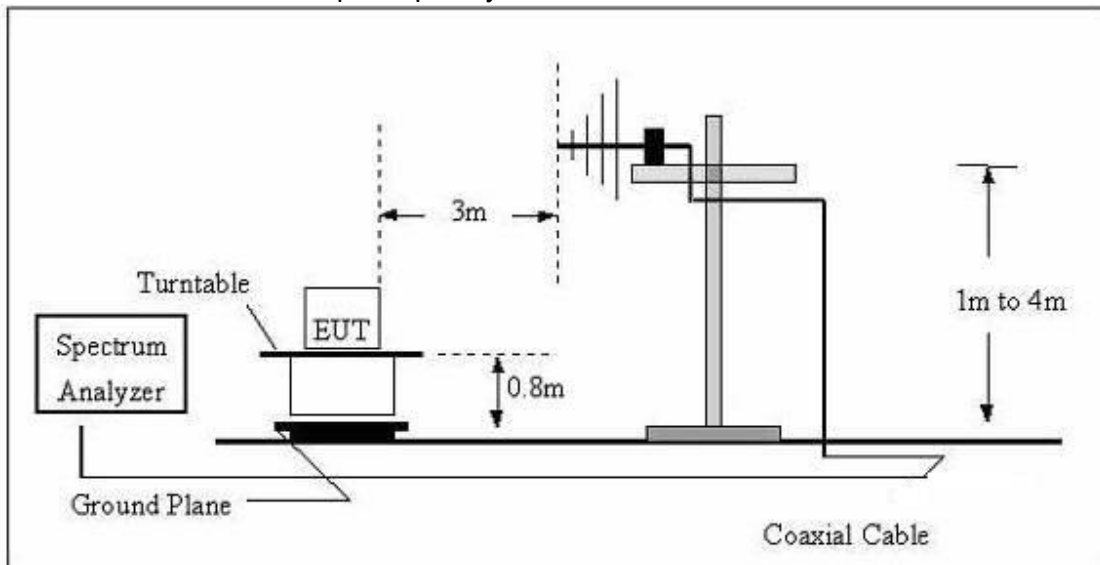

(C) Radiated Emission Test-Up Frequency Above 1GHz

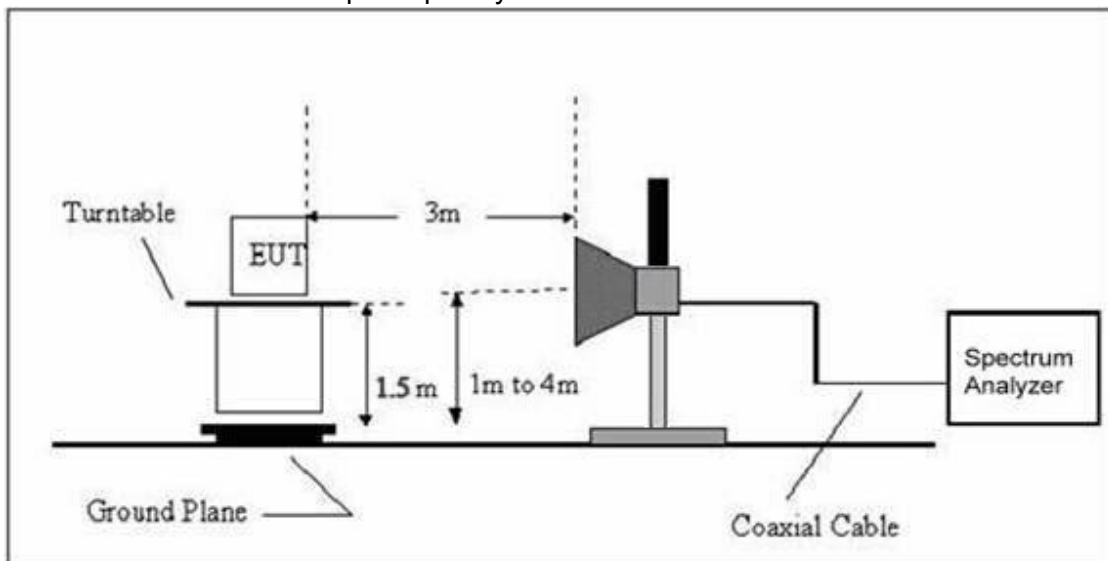

3.2.5 EUT OPERATING CONDITIONS

The EUT tested system was configured as the statements of 2.3 Unless otherwise a special operating condition is specified in the follows during the testing.

**3.2.6 TEST RESULTS (BETWEEN 9KHZ – 30 MHZ)**

Temperature:	20°C	Relative Humidity:	48%
Pressure:	1010 hPa	Test Voltage :	AC 120V/60Hz
Test Mode :	Mode 4	Polarization :	--

Freq. (MHz)	Reading (dBuV/m)	Limit (dBuV/m)	Margin (dB)	State P/F
--	--	--	--	PASS
--	--	--	--	PASS

NOTE:

The amplitude of spurious emissions which are attenuated by more than 20dB below the permissible value has no need to be reported.

Distance extrapolation factor = $40 \log(\text{specific distance}/\text{test distance})$ (dB);

Limit line = specific limits(dBuv) + distance extrapolation factor.



3.2.7 TEST RESULTS (BETWEEN 30MHZ – 1GHZ)

Temperature :	26°C	Relative Humidity :	54%
Pressure :	1010 hPa	Polarization :	Horizontal
Test Voltage :	AC 120V/60Hz		
Test Mode :	Mode 4		

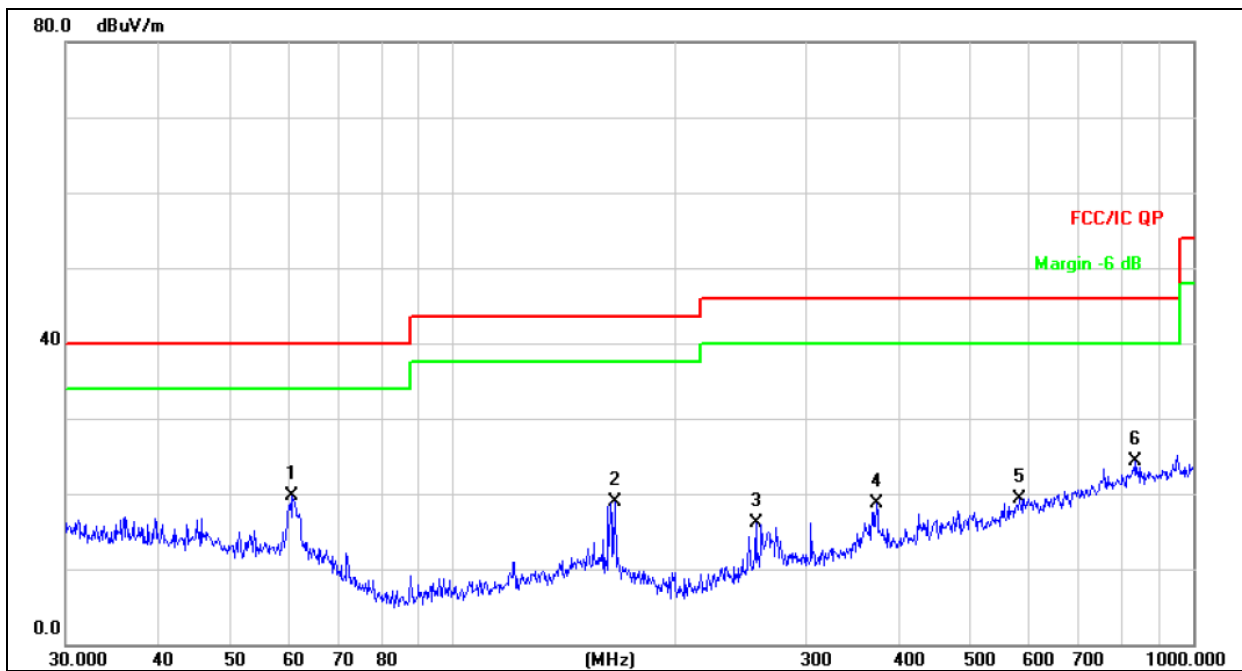

Remark:
 Factor = Antenna Factor + Cable Loss – Pre-amplifier.
 All interfaces was connected, and BT TX mode was link.

No.	Mk.	Freq.	Reading Level	Correct Factor	Measurement	Limit	Over	Antenna Height	Table Degree	
		MHz	dBuV	dB/m	dBuV/m	dBuV/m	dB	cm	degree	Comment
1	*	60.7044	31.32	-11.66	19.66	40.00	-20.34	QP		
2		165.4866	32.05	-13.19	18.86	43.50	-24.64	QP		
3		256.5211	30.16	-14.01	16.15	46.00	-29.85	QP		
4		373.3112	29.46	-10.85	18.61	46.00	-27.39	QP		
5		582.7425	25.52	-6.20	19.32	46.00	-26.68	QP		
6		836.2443	26.42	-2.19	24.23	46.00	-21.77	QP		



Temperature :	26°C	Relative Humidity :	54%
Pressure :	1010 hPa	Polarization :	Vertical
Test Voltage :	AC 120V/60Hz		
Test Mode :	Mode 4		

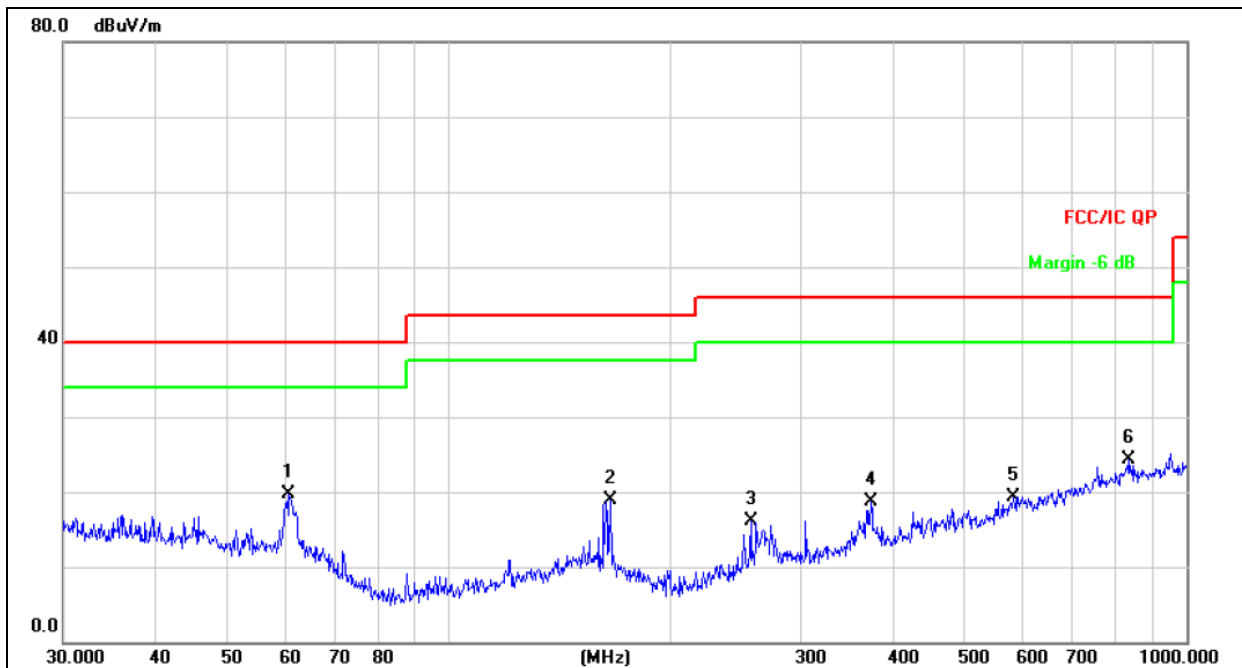

Remark:
 Factor = Antenna Factor + Cable Loss – Pre-amplifier.
 All interfaces was connected, and BT TX mode was link.

No.	Mk.	Freq.	Reading Level	Correct Factor	Measurement	Limit	Over	Antenna Height	Table Degree	
		MHz	dBuV	dB/m	dBuV/m	dBuV/m	dB	cm	degree	Comment
1	*	60.7044	31.32	-11.66	19.66	40.00	-20.34	QP		
2		165.4866	32.05	-13.19	18.86	43.50	-24.64	QP		
3		256.5211	30.16	-14.01	16.15	46.00	-29.85	QP		
4		373.3112	29.46	-10.85	18.61	46.00	-27.39	QP		
5		582.7425	25.52	-6.20	19.32	46.00	-26.68	QP		
6		836.2443	26.42	-2.19	24.23	46.00	-21.77	QP		



3.2.8 TEST RESULTS (1GHZ~25GHZ)

GFSK

Polar (H/V)	Frequency	Meter Reading	Factor	Emission Level	Limits	Margin	Detector Type
	(MHz)	(dBUV)	(dB)	(dBUV/m)	(dBUV/m)	(dB)	
operation frequency:2402							
V	2402.00	88.69	13.85	102.54	114.00	-11.46	PK
V	2402.00	73.30	13.85	87.15	94.00	-6.85	AV
V	4804.00	39.64	19.34	58.98	74.00	-15.02	PK
V	4804.00	25.90	19.34	45.24	54.00	-8.76	AV
V	16128.00	30.13	21.89	52.02	74.00	-21.98	PK
H	2402.00	88.66	13.85	102.51	114.00	-11.49	PK
H	2402.00	73.91	13.85	87.76	94.00	-6.24	AV
H	4804.00	40.47	19.34	59.81	74.00	-14.19	PK
H	4804.00	25.79	19.34	45.13	54.00	-8.87	AV
H	16128.00	29.88	21.89	51.77	74.00	-22.23	PK
operation frequency:2441							
V	2441.00	89.20	13.94	103.14	114.00	-10.86	PK
V	2441.00	73.44	13.94	87.38	94.00	-6.62	AV
V	4882.00	40.58	19.42	60.00	74.00	-14.00	PK
V	4882.00	25.94	19.42	45.36	54.00	-8.64	AV
V	16128.00	28.38	21.89	50.27	74.00	-23.73	PK
H	2441.00	89.22	13.94	103.16	114.00	-10.84	PK
H	2441.00	74.33	13.94	88.27	94.00	-5.73	AV
H	4882.00	41.65	19.42	61.07	74.00	-12.93	PK
H	4882.00	26.68	19.42	46.10	54.00	-7.90	AV
H	16128.00	30.05	21.89	51.94	74.00	-22.06	PK
operation frequency:2480							
V	2480.00	89.25	14.02	103.27	114.00	-10.73	PK
V	2480.00	73.54	14.02	87.56	94.00	-6.44	AV
V	4960.00	41.38	19.51	60.89	74.00	-13.11	PK
V	4960.00	26.22	19.51	45.73	54.00	-8.27	AV
V	16128.00	30.26	21.89	52.15	74.00	-21.85	PK
H	2480.00	89.28	14.02	103.30	114.00	-10.70	PK
H	2480.00	73.39	14.02	87.41	94.00	-6.59	AV
H	4960.00	41.60	19.51	61.11	74.00	-12.89	PK
H	4960.00	26.26	19.51	45.77	54.00	-8.23	AV
H	16128.00	30.59	21.89	52.48	74.00	-21.52	PK

Remark:

1. Emission Level = Meter Reading + Factor, Margin= Emission Level - Limit
2. If peak below the average limit, the average emission was no test.
3. The amplitude of spurious emissions which are attenuated by more than 20dB below the permissible value has no need to be reported.



PI/4 DPSK

Polar (H/V)	Frequency	Meter Reading	Factor	Emission Level	Limits	Margin	Detector Type
	(MHz)	(dBuV)	(dB)	(dBuV/m)	(dBuV/m)	(dB)	
operation frequency:2402							
V	2402.00	88.62	13.85	102.47	114.00	-11.53	PK
V	2402.00	73.24	13.85	87.09	94.00	-6.91	AV
V	4804.00	39.60	19.34	58.94	74.00	-15.06	PK
V	4804.00	25.88	19.34	45.22	54.00	-8.78	AV
V	16128.00	30.10	21.89	51.99	74.00	-22.01	PK
H	2402.00	88.59	13.85	102.44	114.00	-11.56	PK
H	2402.00	73.85	13.85	87.70	94.00	-6.30	AV
H	4804.00	40.43	19.34	59.77	74.00	-14.23	PK
H	4804.00	25.77	19.34	45.11	54.00	-8.89	AV
H	16128.00	29.85	21.89	51.74	74.00	-22.26	PK
operation frequency:2441							
V	2441.00	89.13	13.94	103.07	114.00	-10.93	PK
V	2441.00	73.38	13.94	87.32	94.00	-6.68	AV
V	4882.00	40.53	19.42	59.95	74.00	-14.05	PK
V	4882.00	25.92	19.42	45.34	54.00	-8.66	AV
V	16128.00	28.36	21.89	50.25	74.00	-23.75	PK
H	2441.00	89.15	13.94	103.09	114.00	-10.91	PK
H	2441.00	74.27	13.94	88.21	94.00	-5.79	AV
H	4882.00	41.62	19.42	61.04	74.00	-12.96	PK
H	4882.00	26.66	19.42	46.08	54.00	-7.92	AV
H	16128.00	30.02	21.89	51.91	74.00	-22.09	PK
operation frequency:2480							
V	2480.00	89.18	14.02	103.20	114.00	-10.80	PK
V	2480.00	73.48	14.02	87.50	94.00	-6.50	AV
V	4960.00	41.35	19.51	60.86	74.00	-13.14	PK
V	4960.00	26.20	19.51	45.71	54.00	-8.29	AV
V	16128.00	30.23	21.89	52.12	74.00	-21.88	PK
H	2480.00	89.21	14.02	103.23	114.00	-10.77	PK
H	2480.00	73.33	14.02	87.35	94.00	-6.65	AV
H	4960.00	41.57	19.51	61.08	74.00	-12.92	PK
H	4960.00	26.23	19.51	45.74	54.00	-8.26	AV
H	16128.00	30.56	21.89	52.45	74.00	-21.55	PK

Remark:

1. Emission Level = Meter Reading + Factor, Margin= Emission Level - Limit
2. If peak below the average limit, the average emission was no test.
3. The amplitude of spurious emissions which are attenuated by more than 20dB below the permissible value has no need to be reported.



8DPSK

Polar (H/V)	Frequency	Meter Reading	Factor	Emission Level	Limits	Margin	Detector Type
	(MHz)	(dBuV)	(dB)	(dBuV/m)	(dBuV/m)	(dB)	
operation frequency:2402							
V	2402.00	88.16	13.85	102.01	114.00	-11.99	PK
V	2402.00	72.88	13.85	86.73	94.00	-7.27	AV
V	4804.00	39.41	19.34	58.75	74.00	-15.25	PK
V	4804.00	25.75	19.34	45.09	54.00	-8.91	AV
V	16128.00	29.96	21.89	51.85	74.00	-22.15	PK
H	2402.00	88.13	13.85	101.98	114.00	-12.02	PK
H	2402.00	73.48	13.85	87.33	94.00	-6.67	AV
H	4804.00	40.23	19.34	59.57	74.00	-14.43	PK
H	4804.00	25.64	19.34	44.98	54.00	-9.02	AV
H	16128.00	29.70	21.89	51.59	74.00	-22.41	PK
operation frequency:2441							
V	2441.00	88.68	13.94	102.62	114.00	-11.38	PK
V	2441.00	73.01	13.94	86.95	94.00	-7.05	AV
V	4882.00	40.33	19.42	59.75	74.00	-14.25	PK
V	4882.00	25.79	19.42	45.21	54.00	-8.79	AV
V	16128.00	28.22	21.89	50.11	74.00	-23.89	PK
H	2441.00	88.70	13.94	102.64	114.00	-11.36	PK
H	2441.00	73.90	13.94	87.84	94.00	-6.16	AV
H	4882.00	41.41	19.42	60.83	74.00	-13.17	PK
H	4882.00	26.53	19.42	45.95	54.00	-8.05	AV
H	16128.00	29.87	21.89	51.76	74.00	-22.24	PK
operation frequency:2480							
V	2480.00	88.73	14.02	102.75	114.00	-11.25	PK
V	2480.00	73.11	14.02	87.13	94.00	-6.87	AV
V	4960.00	41.14	19.51	60.65	74.00	-13.35	PK
V	4960.00	26.07	19.51	45.58	54.00	-8.42	AV
V	16128.00	30.08	21.89	51.97	74.00	-22.03	PK
H	2480.00	88.76	14.02	102.78	114.00	-11.22	PK
H	2480.00	72.97	14.02	86.99	94.00	-7.01	AV
H	4960.00	41.36	19.51	60.87	74.00	-13.13	PK
H	4960.00	26.10	19.51	45.61	54.00	-8.39	AV
H	16128.00	30.41	21.89	52.30	74.00	-21.70	PK
Remark: 1. Emission Level = Meter Reading + Factor, Margin= Emission Level - Limit 2. If peak below the average limit, the average emission was no test. 3. The amplitude of spurious emissions which are attenuated by more than 20dB below the permissible value has no need to be reported.							



3.3 RADIATED BAND EMISSION MEASUREMENT

3.3.1 TEST REQUIREMENT:

FCC Part15 C Section 15.209 and 15.205

LIMITS OF RADIATED EMISSION MEASUREMENT (Above 1000MHz)

FREQUENCY (MHz)	Class B (dBuV/m) (at 3M)	
	PEAK	AVERAGE
Above 1000	74	54

Notes:

- (1) The limit for radiated test was performed according to FCC PART 15C.
- (2) The tighter limit applies at the band edges.
- (3) Emission level (dBuV/m)=20log Emission level (uV/m).

Spectrum Parameter	Setting
Attenuation	Auto
Start Frequency	2300MHz
Stop Frequency	2520
RB / VB (emission in restricted band)	1 MHz / 1 MHz for Peak, 1 MHz / 10Hz for Average

3.3.2 TEST PROCEDURE

Above 1GHz test procedure as below:

- a. 1. The EUT was placed on the top of a rotating table 1.5 meters above the ground at a 3 meter camber. The table was rotated 360 degrees to determine the position of the highest radiation.
- b. The EUT was set 3 meters away from the interference-receiving antenna, which was mounted on the top of a variable-height antenna tower.
- c. The antenna height is varied from one meter to four meters above the ground to determine the maximum value of the field strength. Both horizontal and vertical polarizations of the antenna are set to make the measurement.
- d. For each suspected emission, the EUT was arranged to its worst case and then the antenna was tuned to heights from 1 meter to 4 meters and the rota table was turned from 0 degrees to 360 degrees to find the maximum reading.
- e. The test-receiver system was set to Peak Detect Function and Specified Bandwidth with Maximum Hold Mode.
- f. If the emission level of the EUT in peak mode was 10dB lower than the limit specified, then testing could be stopped and the peak values of the EUT would be reported. Otherwise the emissions that did not have 10dB margin would be re-tested one by one using peak, quasi-peak or average method as specified and then reported in a data sheet.
- g. Test the EUT in the lowest channel,the Highest channel

Note:

Both horizontal and vertical antenna polarities were tested and performed pretest to three orthogonal axis. The worst case emissions were reported

3.3.3 DEVIATION FROM TEST STANDARD

No deviation

3.3.4 TEST SETUP

Radiated Emission Test-Up Frequency Above 1GHz

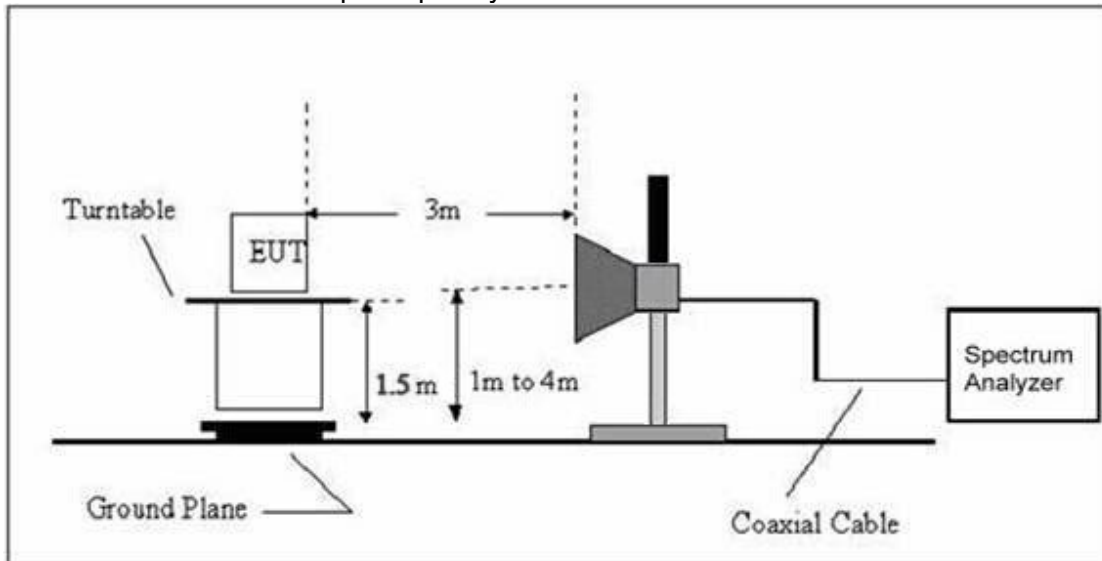

3.3.5 EUT OPERATING CONDITIONS

The EUT tested system was configured as the statements of 2.3 Unless otherwise a special operating condition is specified in the follows during the testing.



3.3.6 TEST RESULT

GFSK

Polar (H/V)	Frequency	Meter Reading	Factor	Emission Level	Limits	Margin	Detector Type
	(MHz)	(dBuV)	(dB)	(dBuV/m)	(dBuV/m)	(dB)	
operation frequency:2402							
V	2390.00	37.44	13.83	51.27	74.00	-22.73	PK
V	2390.00	26.02	13.83	39.85	54.00	-14.15	AV
V	2400.00	37.65	13.85	51.50	74.00	-22.50	PK
V	2400.00	25.59	13.85	39.44	54.00	-14.56	AV
H	2390.00	37.74	13.83	51.57	74.00	-22.43	PK
H	2390.00	26.05	13.83	39.88	54.00	-14.12	AV
H	2400.00	37.60	13.85	51.45	74.00	-22.55	PK
H	2400.00	25.99	13.85	39.84	54.00	-14.16	AV

Polar (H/V)	Frequency	Meter Reading	Factor	Emission Level	Limits	Margin	Detector Type
	(MHz)	(dBuV)	(dB)	(dBuV/m)	(dBuV/m)	(dB)	
operation frequency:2480							
V	2483.50	37.65	14.02	51.67	74.00	-22.33	PK
V	2483.50	26.28	14.02	40.30	54.00	-13.70	AV
V	2500.00	37.59	14.06	51.65	74.00	-22.35	PK
V	2500.00	25.69	14.06	39.75	54.00	-14.25	AV
H	2483.50	37.78	14.02	51.80	74.00	-22.20	PK
H	2483.50	26.32	14.02	40.34	54.00	-13.66	AV
H	2500.00	37.40	14.06	51.46	74.00	-22.54	PK
H	2500.00	26.56	14.06	40.62	54.00	-13.38	AV

Remark:

1. Emission Level = Meter Reading + Factor, Margin= Emission Level - Limit
2. If peak below the average limit, the average emission was no test.
3. The amplitude of spurious emissions which are attenuated by more than 20dB below the permissible value has no need to be reported.



PI/4 DPSK

Polar (H/V)	Frequency	Meter Reading	Factor	Emission Level	Limits	Margin	Detector Type
	(MHz)	(dBuV)	(dB)	(dBuV/m)	(dBuV/m)	(dB)	
operation frequency:2402							
V	2390.00	37.33	13.83	51.16	74.00	-22.84	PK
V	2390.00	25.93	13.83	39.76	54.00	-14.24	AV
V	2400.00	37.53	13.85	51.38	74.00	-22.62	PK
V	2400.00	25.50	13.85	39.35	54.00	-14.65	AV
H	2390.00	37.62	13.83	51.45	74.00	-22.55	PK
H	2390.00	25.96	13.83	39.79	54.00	-14.21	AV
H	2400.00	37.48	13.85	51.33	74.00	-22.67	PK
H	2400.00	25.90	13.85	39.75	54.00	-14.25	AV

Polar (H/V)	Frequency	Meter Reading	Factor	Emission Level	Limits	Margin	Detector Type
	(MHz)	(dBuV)	(dB)	(dBuV/m)	(dBuV/m)	(dB)	
operation frequency:2480							
V	2483.50	37.53	14.02	51.55	74.00	-22.45	PK
V	2483.50	26.18	14.02	40.20	54.00	-13.80	AV
V	2500.00	37.47	14.06	51.53	74.00	-22.47	PK
V	2500.00	25.60	14.06	39.66	54.00	-14.34	AV
H	2483.50	37.66	14.02	51.68	74.00	-22.32	PK
H	2483.50	26.22	14.02	40.24	54.00	-13.76	AV
H	2500.00	37.28	14.06	51.34	74.00	-22.66	PK
H	2500.00	26.47	14.06	40.53	54.00	-13.47	AV

Remark:

1. Emission Level = Meter Reading + Factor, Margin= Emission Level - Limit
2. If peak below the average limit, the average emission was no test.
3. The amplitude of spurious emissions which are attenuated by more than 20dB below the permissible value has no need to be reported.



8DPSK

Polar (H/V)	Frequency	Meter Reading	Factor	Emission Level	Limits	Margin	Detector Type
	(MHz)	(dBuV)	(dB)	(dBuV/m)	(dBuV/m)	(dB)	
operation frequency:2402							
V	2390.00	37.27	13.83	51.10	74.00	-22.90	PK
V	2390.00	25.89	13.83	39.72	54.00	-14.28	AV
V	2400.00	37.47	13.85	51.32	74.00	-22.68	PK
V	2400.00	25.47	13.85	39.32	54.00	-14.68	AV
H	2390.00	37.56	13.83	51.39	74.00	-22.61	PK
H	2390.00	25.92	13.83	39.75	54.00	-14.25	AV
H	2400.00	37.43	13.85	51.28	74.00	-22.72	PK
H	2400.00	25.86	13.85	39.71	54.00	-14.29	AV

Polar (H/V)	Frequency	Meter Reading	Factor	Emission Level	Limits	Margin	Detector Type
	(MHz)	(dBuV)	(dB)	(dBuV/m)	(dBuV/m)	(dB)	
operation frequency:2480							
V	2483.50	37.47	14.02	51.49	74.00	-22.51	PK
V	2483.50	26.14	14.02	40.16	54.00	-13.84	AV
V	2500.00	37.42	14.06	51.48	74.00	-22.52	PK
V	2500.00	25.56	14.06	39.62	54.00	-14.38	AV
H	2483.50	37.60	14.02	51.62	74.00	-22.38	PK
H	2483.50	26.18	14.02	40.20	54.00	-13.80	AV
H	2500.00	37.22	14.06	51.28	74.00	-22.72	PK
H	2500.00	26.43	14.06	40.49	54.00	-13.51	AV

Remark:

1. Emission Level = Meter Reading + Factor, Margin= Emission Level - Limit
2. If peak below the average limit, the average emission was no test.
3. The amplitude of spurious emissions which are attenuated by more than 20dB below the permissible value has no need to be reported.



4. BANDWIDTH TEST

4.1 APPLIED PROCEDURES / LIMIT

FCC Part15 (15.249) , Subpart C	
Section	Test Item
15.249	Bandwidth

4.1.1 TEST PROCEDURE

1. Set RBW = 30 kHz.
2. Set the video bandwidth (VBW) $\geq 3 \times$ RBW.
3. Detector = Peak.
4. Trace mode = max hold.
5. Sweep = auto couple.
6. Allow the trace to stabilize.
7. Measure the maximum width of the emission that is constrained by the frequencies associated with the two outermost amplitude points (upper and lower frequencies) that are attenuated by 6 dB relative to the maximum level measured in the fundamental emission.

4.1.2 DEVIATION FROM STANDARD

No deviation.

4.1.3 TEST SETUP



4.1.4 EUT OPERATION CONDITIONS

The EUT tested system was configured as the statements of 2.3 Unless otherwise a special operating condition is specified in the follows during the testing.



4.1.5 TEST RESULTS

Temperature :	25°C	Relative Humidity :	60%
Pressure :	1012 hPa	Test Voltage :	DC 3.7V
Test Mode :	TX Mode /CH00, CH39, CH78		

	Frequency (MHz)	20dB bandwidth (MHz)	Result
GFSK	2402	0.968	Pass
	2441	0.963	Pass
	2480	0.962	Pass
PI/4 DPSK	2402	1.256	Pass
	2441	1.329	Pass
	2480	1.340	Pass
8DPSK	2402	1.346	Pass
	2441	1.326	Pass
	2480	1.311	Pass

GFSK

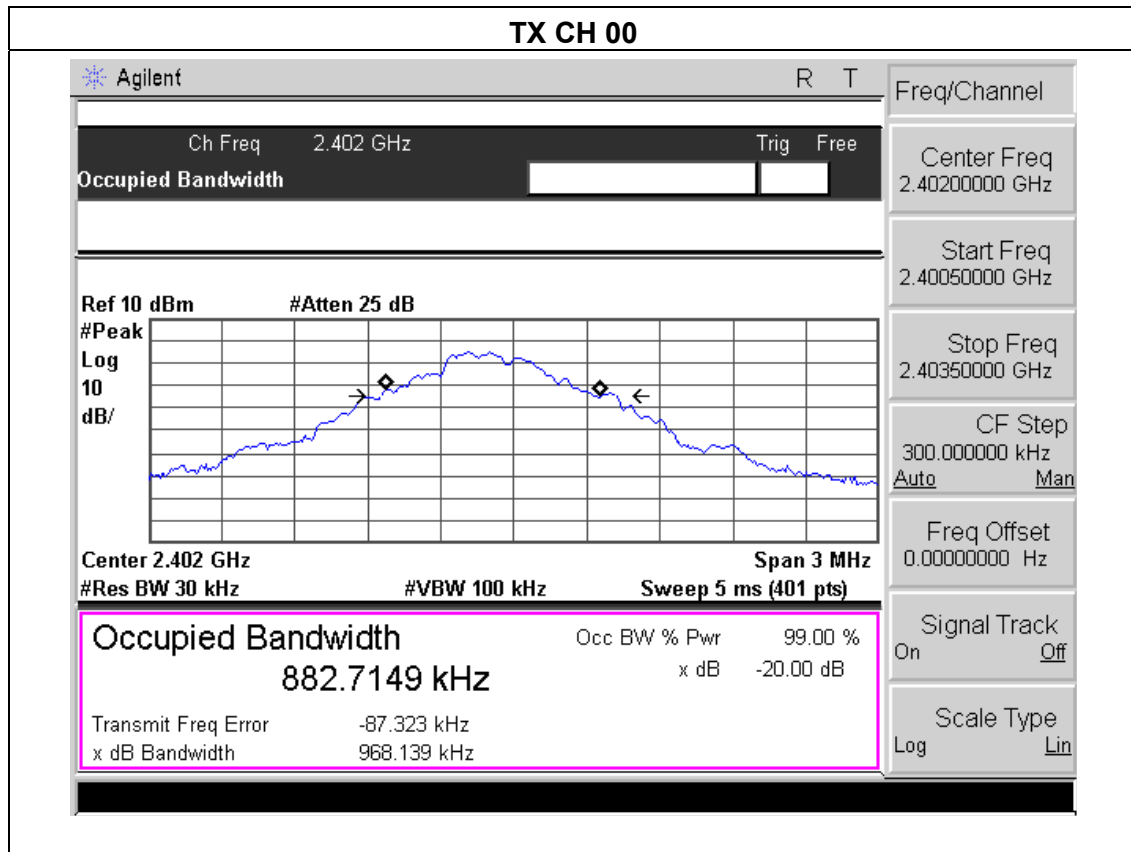

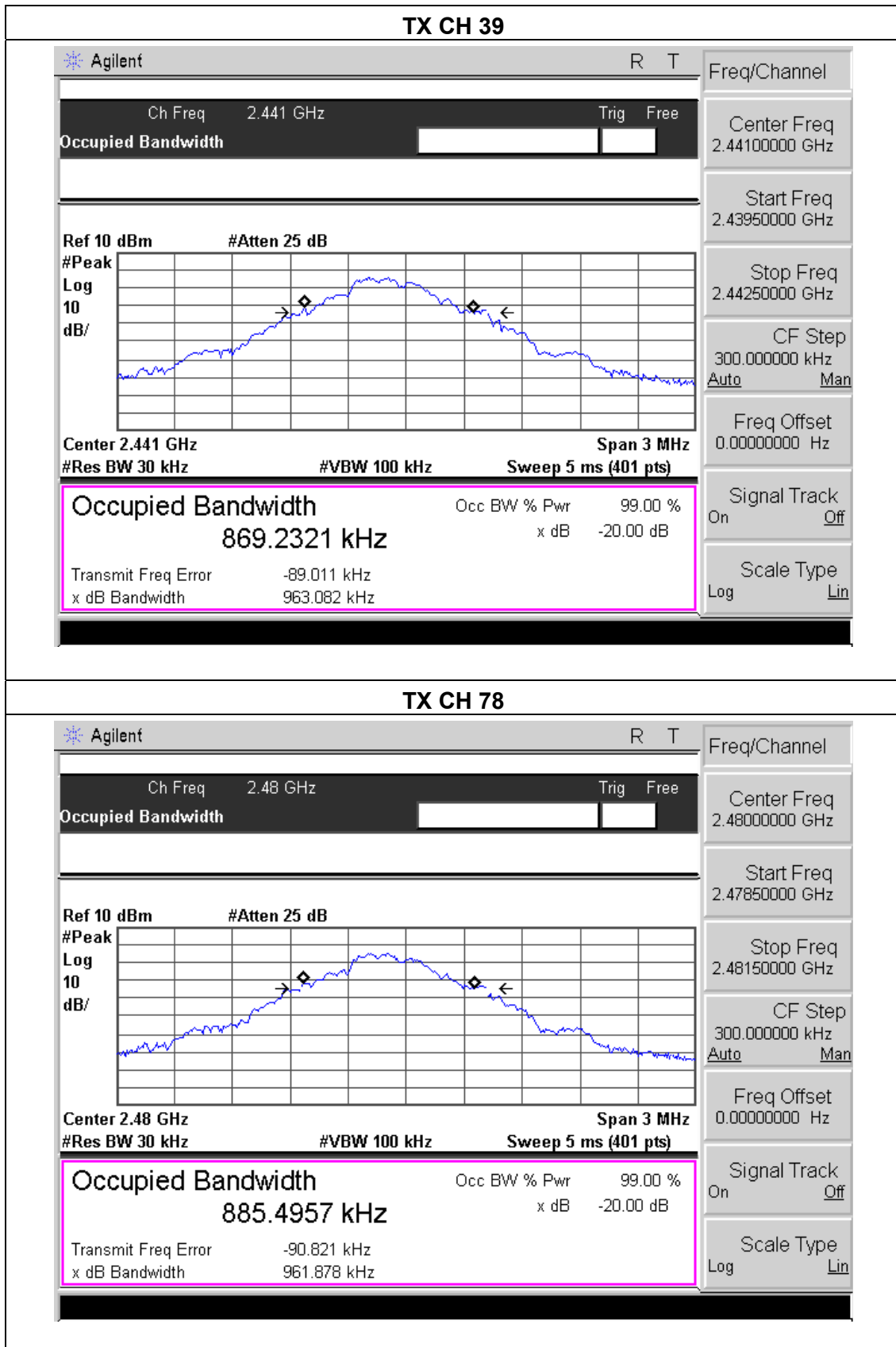



PI/4 DPSK

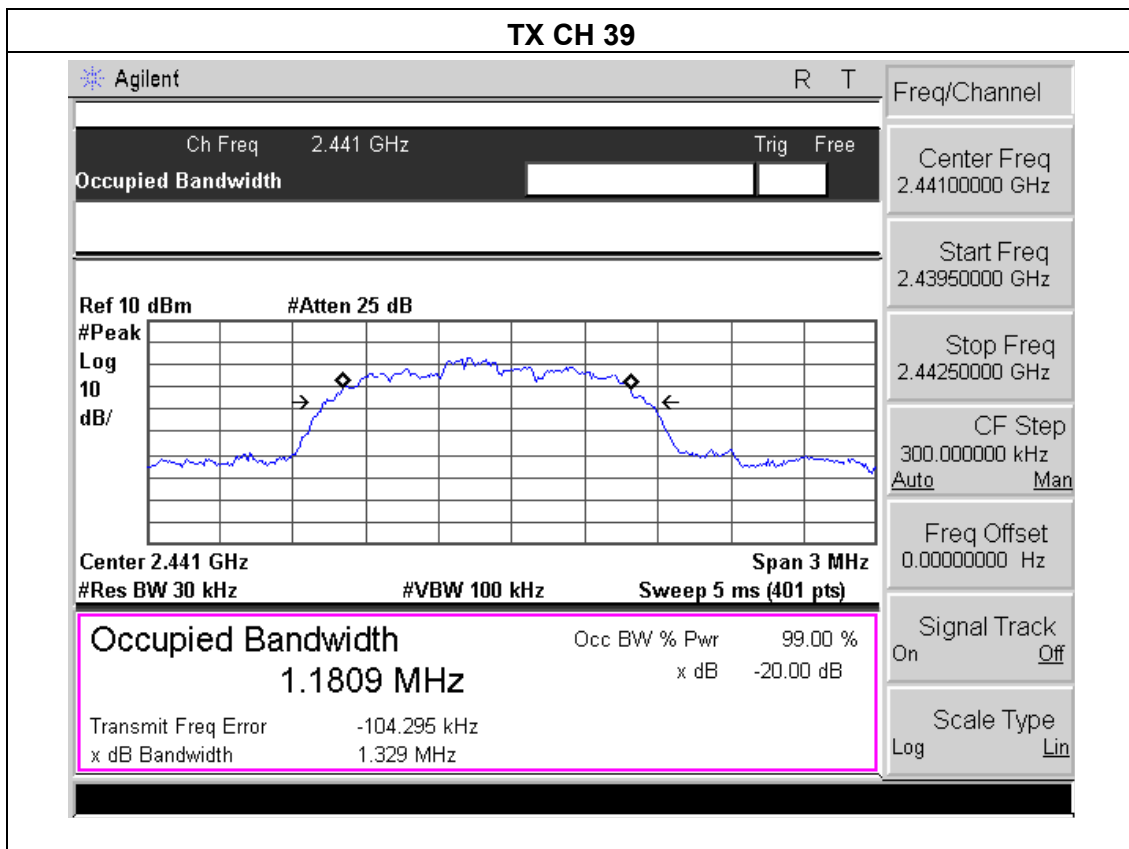
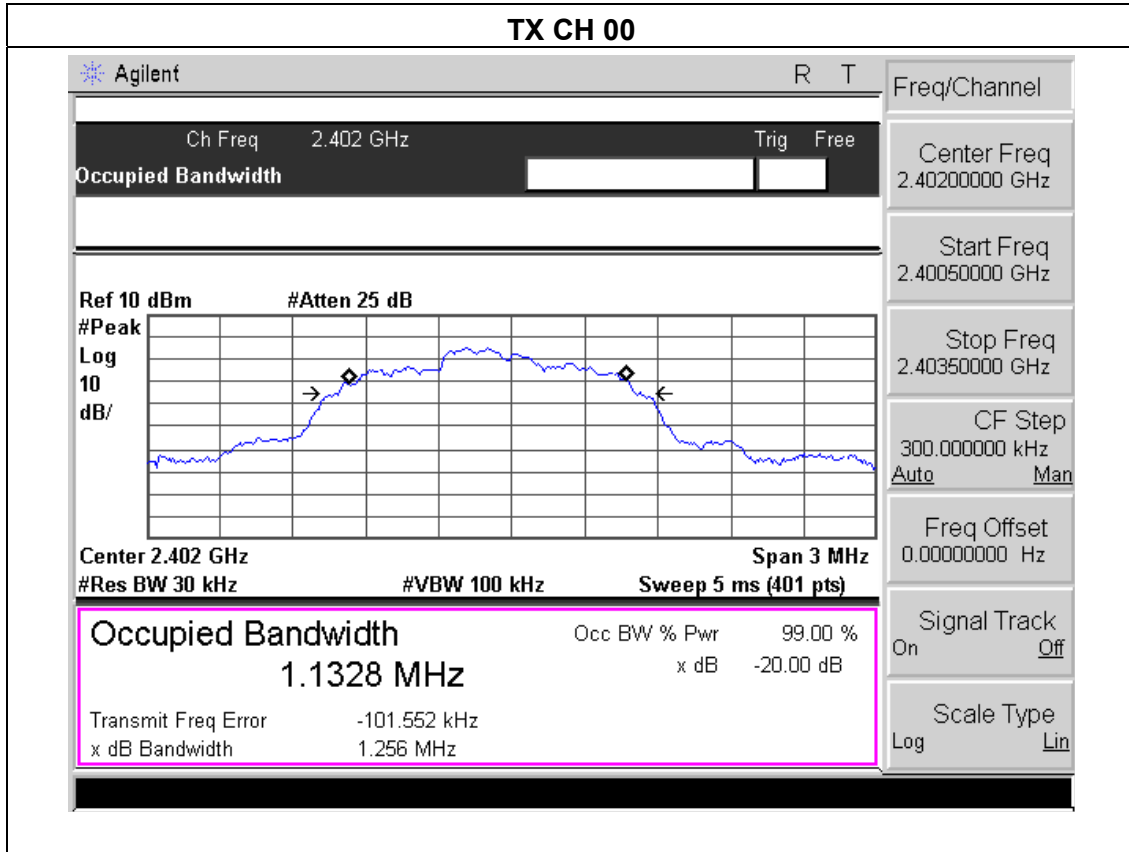

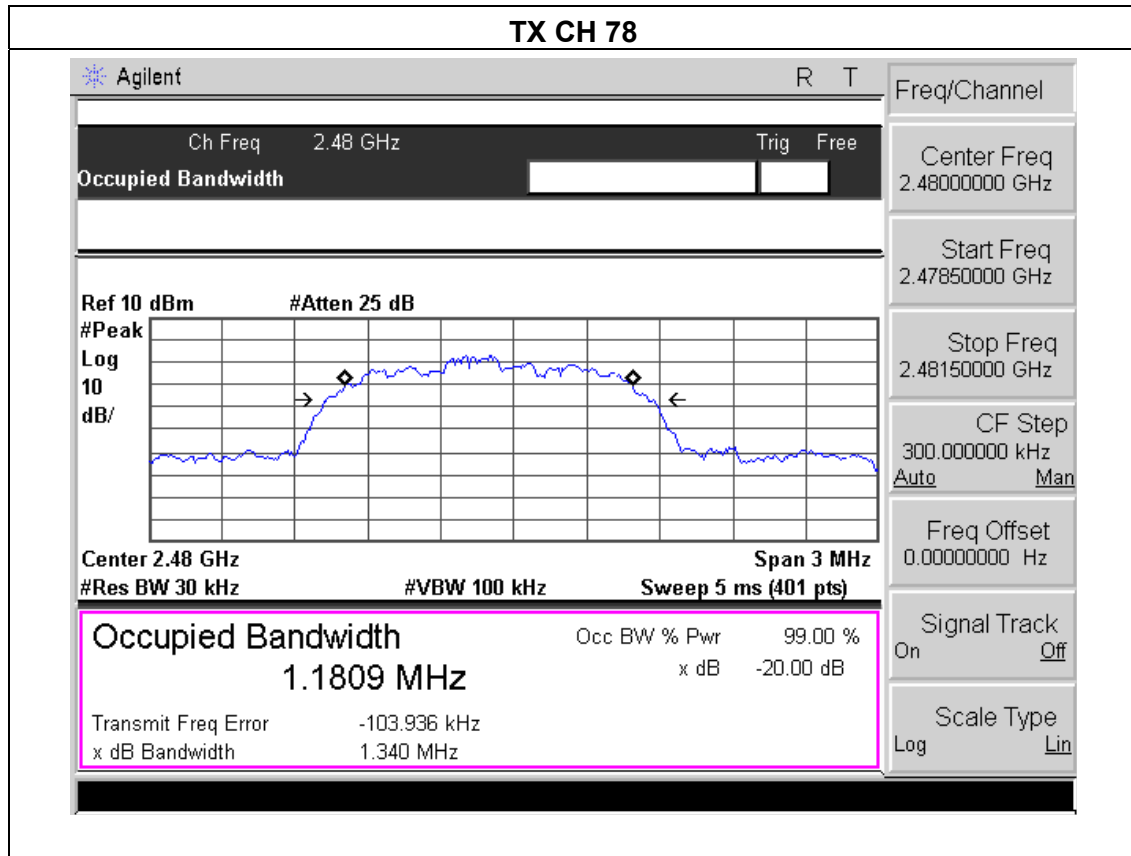

8DPSK

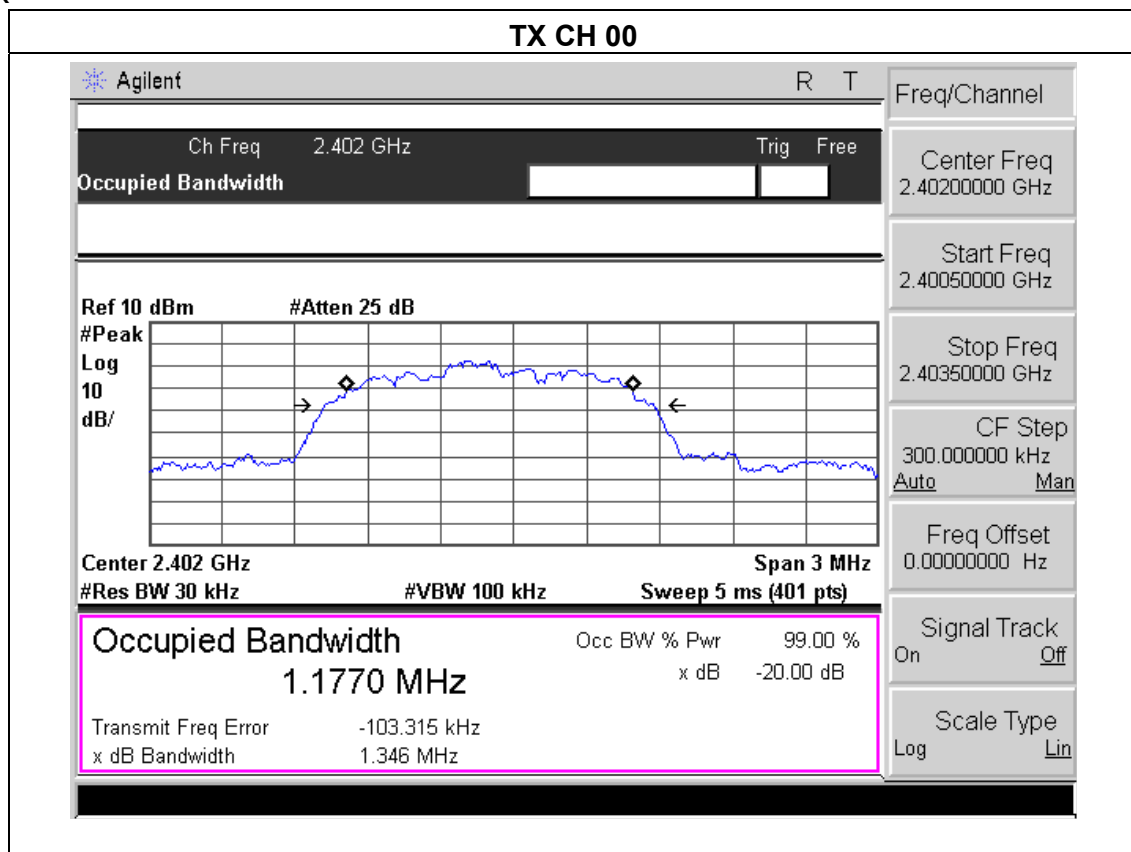

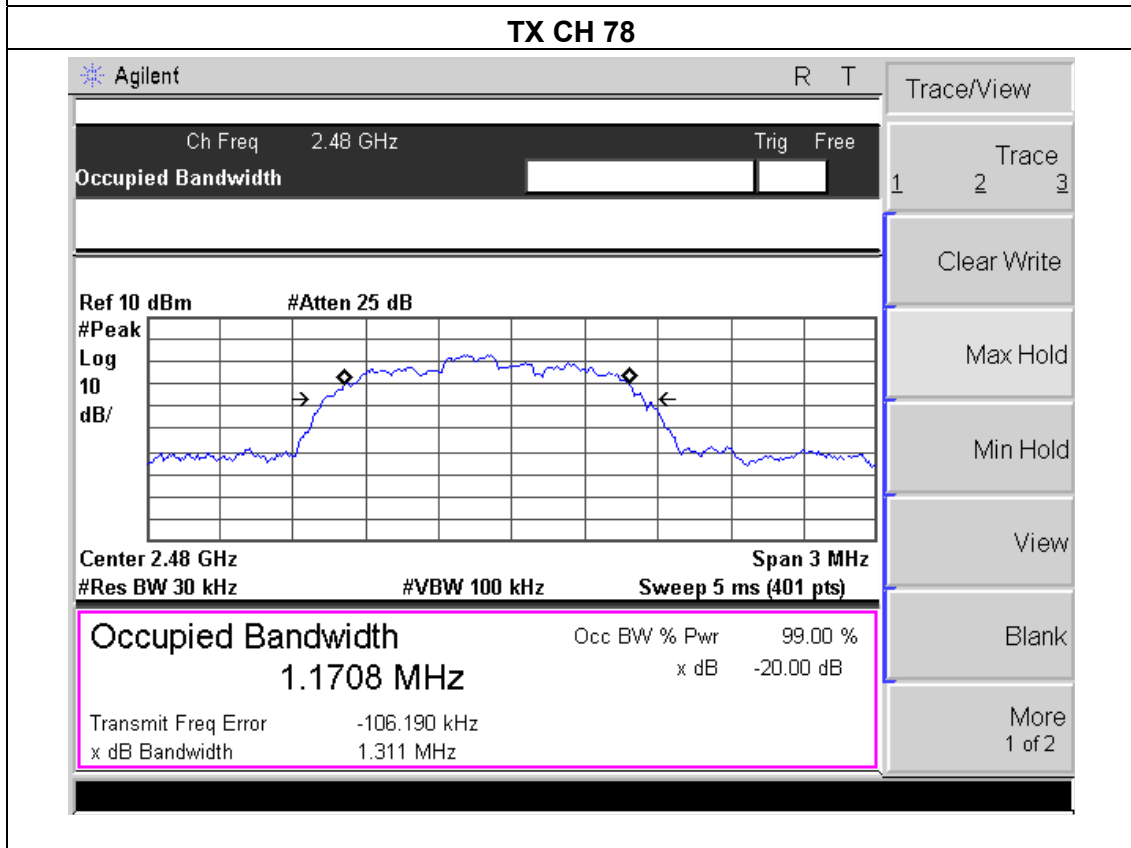
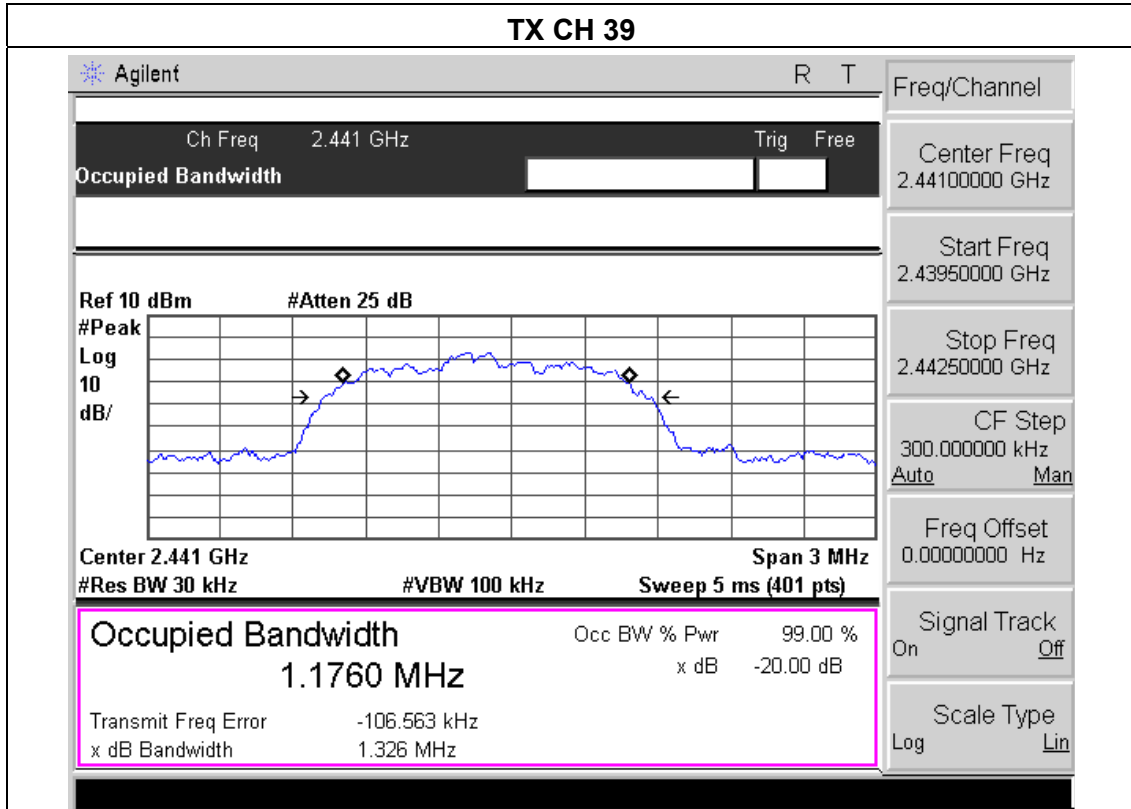



5. ANTENNA REQUIREMENT

5.1 STANDARD REQUIREMENT

15.203 requirement: For intentional device, according to 15.203: an intentional radiator shall be designed to ensure that no antenna other than that furnished by the responsible party shall be used with the device.

5.2 EUT ANTENNA

The EUT antenna is PCB antenna,. It comply with the standard requirement.

6. TEST SEUUP PHOTO

Radiated Measurement Photos



Conducted Measurement Photos



7. EUT PHOTO

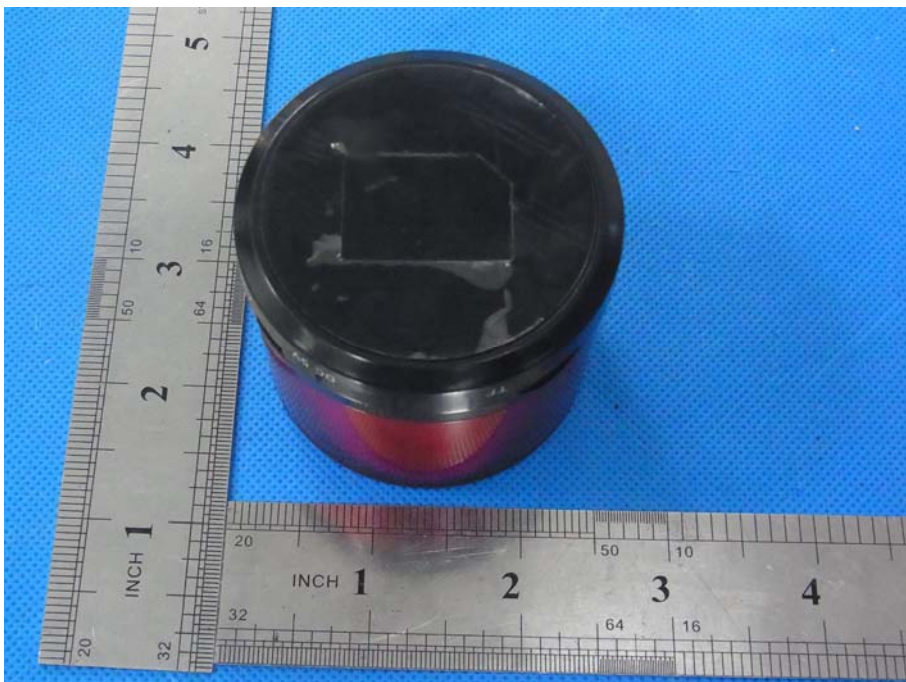
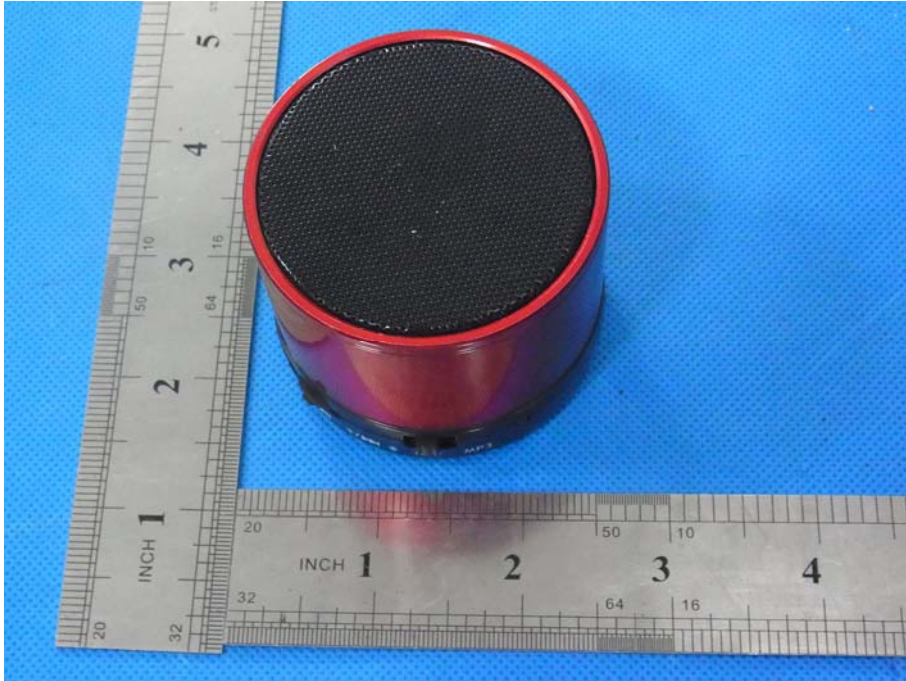

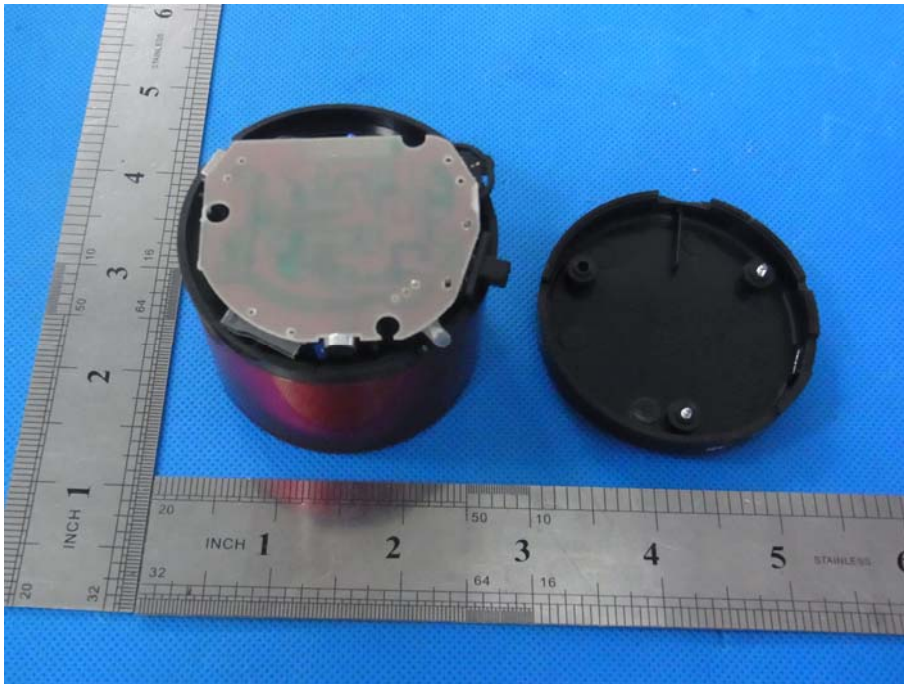

***** END OF REPORT *****