



# FCC Part 15C Test Report

## FCC ID:2AJAQ-LLR02

Product Name:	The Festive Light remote control
Trademark:	N/A
Model Name :	LLR02
Serial Model	N/A
Prepared For :	<b>CREATIVE CONCEPTS (USA)</b>
Address :	50 Harrison Street,Suite 112,Hoboken,NJ 07030,USA.
Prepared By :	<b>Shenzhen BCTC Technology Co., Ltd.</b>
Address :	No.101, Yousong Road, Longhua New District, Shenzhen,China
Test Date:	<b>Dec 02 - Dec 09, 2016</b>
Date of Report :	<b>Dec 19, 2016</b>
Report No.:	<b>BCTC-FY161206025E</b>



### VERIFICATION OF COMPLIANCE

**Applicant's name**..... **CREATIVE CONCEPTS (USA)**  
**Address**..... 50 Harrison Street,Suite 112,Hoboken,NJ 07030,USA.  
**Manufacture's Name**..... **NINGBO SANFENG ELECTRICAL CO.,LTD**  
**Address**..... NO 10,WANGJIANG ROAD,XIDIANTOWN,NINGHAI,NINGBO, CHINA

#### Product description

**Product name**..... The Festive Light remote control  
**Trademark:** N/A  
**Model Name:** LLR02  
**Test Standards:** FCC Part15.231-2016  
 ANSI C63.10-2013

This device described above has been tested by BCTC, and the test results show that the equipment under test (EUT) is in compliance with the FCC requirements. And it is applicable only to the tested sample identified in the report.

This report shall not be reproduced except in full, without the written approval of BCTC, this document may be altered or revised by BCTC, personal only, and shall be noted in the revision of the document.

Test Result..... : **Pass**

Testing Engineer : Eric Yang  
 Eric Yang

Reviewer (Supervisor) : Simon Wang  
 Simon Wang

Approved & Authorized Signer(Manager) : Carson Zhang  



Table of Contents	Page
<b>. SUMMARY OF TEST RESULTS.....</b>	<b>5</b>
TEST FACILITY.....	6
MEASUREMENT UNCERTAINTY.....	6
<b>. GENERAL INFORMATION.....</b>	<b>7</b>
GENERAL DESCRIPTION OF EUT.....	7
DESCRIPTION OF TEST MODES.....	8
BLOCK DIGRAM SHOWING THE CONFIGURATION OF SYSTEM TESTED.....	8
DESCRIPTION OF SUPPORT UNITS(CONDUCTED MODE).....	8
EQUIPMENTS LIST FOR ALL TEST ITEMS.....	9
<b>. EMC EMISSION TEST.....</b>	<b>10</b>
CONDUCTED EMISSION MEASUREMENT.....	10
POWER LINE CONDUCTED EMISSION LIMITS.....	10
TEST PROCEDURE.....	11
DEVIATION FROM TEST STANDARD.....	11
TEST SETUP.....	11
EUT OPERATING CONDITIONS.....	11
TEST RESULTS.....	12
RADIATED EMISSION MEASUREMENT.....	13
RADIATED EMISSION LIMITS.....	13
TEST PROCEDURE.....	14
TEST SETUP.....	15
EUT OPERATING CONDITIONS.....	16
TEST RESULTS .....	17
<b>. BANDWIDTH TEST.....</b>	<b>22</b>
APPLIED PROCEDURES / LIMIT.....	22
TEST PROCEDURE.....	22
DEVIATION FROM STANDARD.....	22
TEST SETUP.....	22
EUT OPERATION CONDITIONS.....	22
TEST RESULTS.....	23
<b>. CALCULATION OF AVERAGE FACTOR.....</b>	<b>24</b>
<b>. DWELL TIME.....</b>	<b>26</b>
DEVIATION FROM STANDARD.....	26



---

<b>Table of Contents</b>	<b>Page</b>
TEST SETUP.....	26
EUT OPERATION CONDITIONS.....	26
TEST RESULTS.....	27
. ANTENNA REQUIREMENT.....	28
STANDARD REQUIREMENT.....	28
EUT ANTENNA.....	28
. EUT TEST PHOTO.....	29
. EUT PHOTO.....	30
APPENDIX-PHOTOGRAPHS OF EUT CONSTRUCTIONAL DETAILS	

**. SUMMARY OF TEST RESULTS**

Test procedures according to the technical standards:

<b>FCC Part15 (15.231) , Subpart C</b>			
Standard Section	Test Item	Judgment	Remark
15.207	Conducted Emission	N/A	EUT is powered by battery.
15.209,15.231b	Fundamental &Radiated Spurious Emission Measurement	PASS	
15.231c	Occupy Bandwidth	PASS	
15.231a	Dwell time	PASS	
15.203	Antenna Requirement	PASS	

**NOTE:**

(1) "N/A" denotes test is not applicable in this Test Report

**TEST FACILITY**

Shenzhen BCTC Technology Co., Ltd.  
Add.:No.101,Yousong Road,Longhua New District, Shenzhen,China  
FCC Registration No.:187086

**MEASUREMENT UNCERTAINTY**

The reported uncertainty of measurement  $y \pm U$ , where expanded uncertainty  $U$  is based on a standard uncertainty multiplied by a coverage factor of  $k=2$ , providing a level of confidence of approximately **95 %**.

No.	Item	Uncertainty
1	Conducted Emission Test	$\pm 1.38\text{dB}$
2	RF power,conducted	$\pm 0.16\text{dB}$
3	Spurious emissions,conducted	$\pm 0.21\text{dB}$
4	All emissions,radiated(<1G)	$\pm 4.68\text{dB}$
5	All emissions,radiated(>1G)	$\pm 4.89\text{dB}$
6	Temperature	$\pm 0.5^{\circ}\text{C}$
7	Humidity	$\pm 2\%$



## GENERAL INFORMATION

### GENERAL DESCRIPTION OF EUT

Equipment	The Festive Light remote control	
Trade Name	N/A	
Model Name	LLR02	
Serial Model	N/A	
Model Difference	N/A	
Product Description	The EUT is a The Festive Light remote control	
	Operation Frequency:	433.92MHz
	Modulation Type:	FSK
	Antenna Designation:	PCB
	Antenna Gain	0dBi
	Based on the application, features, or specification exhibited in User's Manual, the EUT is considered as an ITE/Computing Device. More details of EUT technical specification, please refer to the User's Manual.	
Battery	DC 3V battery	
Connecting I/O Port(s)	Please refer to the User's Manual	
HW version	750129-y200	
SW version	V1.0	

Note:

1. For a more detailed features description, please refer to the manufacturer's specifications or the User's Manual.

**DESCRIPTION OF TEST MODES**

For All Emission	
Final Test Mode	Description
Mode 1	TX Mode

Note:

- (1) New battery is used during the test
- (2) There five button for product, we pretest all mode, only the up button (Mode 1) was worst, all data was in this mode.

**BLOCK DIGRAM SHOWING THE CONFIGURATION OF SYSTEM TESTED**

Radiated Spurious Emission Test

**DESCRIPTION OF SUPPORT UNITS(CONDUCTED MODE)**

The EUT has been tested as an independent unit together with other necessary accessories or support units. The following support units or accessories were used to form a representative test configuration during the tests.

Item	Equipment	Mfr/Brand	Model/Type No.	Series No.	Note
1	The Festive Light remote control	N/A	LLR02	N/A	EUT

Note:

- (1) The support equipment was authorized by Declaration of Confirmation.
- (2) For detachable type I/O cable should be specified the length in cm in 『Length』 column.
- (3) “YES” is means “shielded” “with core”; “NO” is means “unshielded” “without core”.

**EQUIPMENTS LIST FOR ALL TEST ITEMS**

## Radiation Test equipment

Item	Kind of Equipment	Manufacturer	Type No.	Serial No.	Last calibration	Calibrated until	Calibration period
1	Spectrum Analyzer	Agilent	E4407B	MY45108040	2016.07.05	2017.07.04	1 year
2	Test Receiver	R&S	ESPI	101318	2016.06.06	2017.06.05	1 year
3	Bilog Antenna	TESEQ	CBL6111D	31216	2016.07.05	2017.07.04	1 year
4	50Ω Coaxial Switch	Anritsu	MP59B	6200264416	2016.06.06	2017.06.05	1 year
5	Spectrum Analyzer	ADVANTEST	R3132	150900201	2016.06.06	2017.06.05	1 year
6	Horn Antenna	EM	EM-AH-10180	2011071402	2016.07.05	2017.07.04	1 year
7	Horn Ant	Schwarzbeck	BBHA 9170	9170-181	2016.07.05	2017.07.04	1 year
8	Amplifier	EM	EM-30180	060538	2015.12.22	2016.12.21	1 year
9	Loop Antenna	ARA	PLA-1030/B	1029	2016.06.07	2017.06.06	1 year
10	Power Meter	R&S	NRVS	100696	2016.07.05	2017.07.04	1 year
11	Power Sensor	R&S	URV5-Z4	0395.1619.05	2016.07.05	2017.07.04	1 year
12	RF cables	R&S	R203	R20X	2016.07.05	2017.07.04	1 year

## Conduction Test equipment

Item	Kind of Equipment	Manufacturer	Type No.	Serial No.	Last calibration	Calibrated until	Calibration period
1	Test Receiver	R&S	ESCI	101160	2016.06.05	2017.06.04	1 year
2	LISN	R&S	ENV216	101313	2016.08.23	2017.08.22	1 year
3	LISN	EMCO	3816/2	00042990	2016.08.23	2017.08.22	1 year
4	50Ω Coaxial Switch	Anritsu	MP59B	6200264417	2016.06.06	2017.06.05	1 year
5	Passive Voltage Probe	R&S	ESH2-Z3	100196	2016.06.06	2017.06.05	1 year
6	Absorbing clamp	R&S	MOS-21	100423	2016.06.07	2017.06.06	1 year
7	RF cables	R&S	R204	R20X	2016.07.05	2017.07.04	1 year



**. EMC EMISSION TEST**

**CONDUCTED EMISSION MEASUREMENT**

**POWER LINE CONDUCTED EMISSION Limits (Frequency Range 150KHz-30MHz)**

FREQU NCY (MHz)	Class A (dBuV)		Class B (dBuV)		Standard
	Quasi-peak	Average	Quasi-peak	Average	
0.1 -0.5	79.00	66.00	66 - 56 *	56 - 46 *	CISPR
0.50 -5.0	73.00	60.00	56.00	46.00	CISPR
5.0 -30.0	73.00	60.00	60.00	50.00	CISPR

0.15 -0.5	79.00	66.00	66 - 56 *	56 - 46 *	FCC
0.50 -5.0	73.00	60.00	56.00	46.00	FCC
5.0 -30.0	73.00	60.00	60.00	50.00	FCC

Note:

- (1) The tighter limit applies at the band edges.
- (2) The limit of " \* " marked band means the limitation decreases linearly with the logarithm of the frequency in the range.

The following table is the setting of the receiver

Receiver Parameters	Setting
Attenuation	10 dB
Start Frequency	0.15 MHz
Stop Frequency	30 MHz
IF Bandwidth	9 kHz



## TEST PROCEDURE

- The EUT was placed 0.8 meters from the horizontal ground plane with EUT being connected to the power mains through a line impedance stabilization network (LISN). All other support equipments powered from additional LISN(s). The LISN provide 50 Ohm/ 50uH of coupling impedance for the measuring instrument.
- Interconnecting cables that hang closer than 40 cm to the ground plane shall be folded back and forth in the center forming a bundle 30 to 40 cm long.
- I/O cables that are not connected to a peripheral shall be bundled in the center. The end of the cable may be terminated, if required, using the correct terminating impedance. The overall length shall not exceed 1 m.
- LISN at least 80 cm from nearest part of EUT chassis.
- For the actual test configuration, please refer to the related Item –EUT Test Photos.

## DEVIATION FROM TEST STANDARD

No deviation

## TEST SETUP

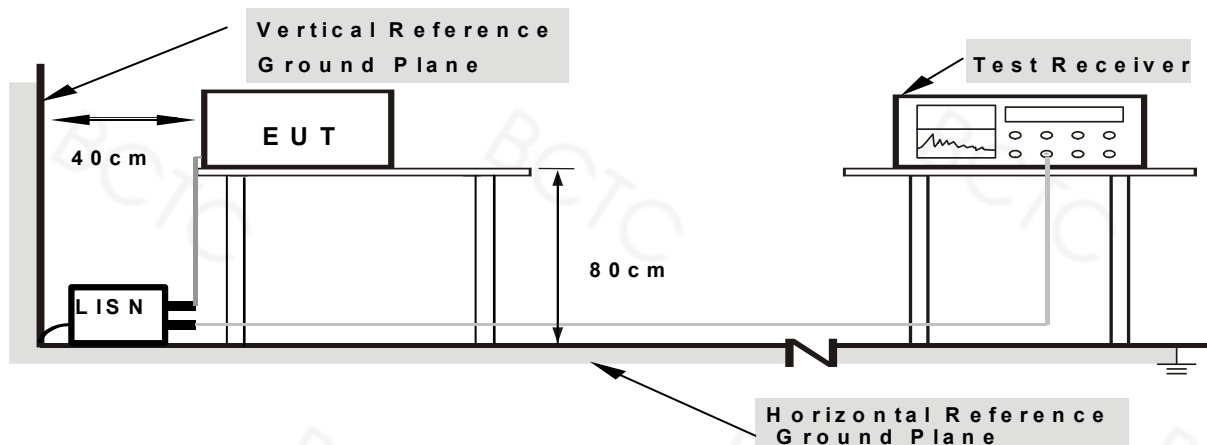

- Note: 1.Support units were connected to second LISN.  
2.Both of LISNs (AMN) are 80 cm from EUT and at least 80 from other units and other metal planes

## EUT OPERATING CONDITIONS

The EUT was configured for testing in a typical fashion (as a customer would normally use it). The EUT has been programmed to continuously transmit during test. This operating condition was tested and used to collect the included data.



**TEST RESULTS**

Temperature :	26 °C	Relative Humidity :	54%
Pressure :	1010hPa	Phase :	L
Test Voltage :	N/A	Test Mode :	TX Mode

NOTE: This EUT is powered by the battery only, this test item is not applicable.



**RADIATED EMISSION MEASUREMENT**

**RADIATED EMISSION LIMITS (Frequency Range 9kHz-1000MHz)**

20dBc in any 100 kHz bandwidth outside the operating frequency band. In case the emission fall within the restricted band specified on 15.205(a), then the 15.231(b) limit in the table below has to be followed.

Frequencies(MHz)	Field Strength(microrvolts/meter)	Measurement Distance(meters)
0.009~0.490	2400/F(KHz)	300
0.490~1.705	24000/F(KHz)	30
1.705~30.0	30	30
30~88	100	3
88~216	150	3
216~960	200	3
Above 960	500	3

**LIMITS OF RADIATED EMISSION MEASUREMENT (Above 1000MHz)**

FREQUENCY (MHz)	Class B (dBuV/m) (at 3M)	
	PEAK	AVERAGE
Above 1000	74	54

Notes:

- (1) The limit for radiated test was performed according to FCC PART 15C.
- (2) The tighter limit applies at the band edges.
- (3) Emission level (dBuV/m)=20log Emission level (uV/m).

**FUNDAMENTAL AND HARMONICS EMISSION LIMITS**

Fundamental Frequency (MHz)	Field Strength of Fundamental (microvolts/meter)	Field Strength of Spurious Emissions (microvolts/meter)
40.66 - 40.70	2,250	225
70 - 130	1,250	125
130 - 174	1,250 to 3,750 **	125 to 375 **
174 - 260	3,750	375
260 - 470	3,750 to 12,500 **	375 to 1,250 **
Above 470	12,500	1,250

\*\* linear interpolations

[Where F is the frequency in MHz, the formulas for calculating the maximum permitted fundamental field strengths are as follows: for the band 130-174 MHz,  $\mu\text{V/m}$  at 3 meters =  $56.81818(F) - 6136.3636$ ; for the band 260-470 MHz,  $\mu\text{V/m}$  at 3 meters =  $41.6667(F) - 7083.3333$ . The maximum permitted unwanted emission level is 20 dB below the maximum permitted fundamental level.]



**FREQUENCY RANGE OF RADIATED MEASUREMENT (For unintentional radiators)**

Highest frequency generated or Upper frequency of measurement used in the device or on which the device operates or tunes (MHz)	Range (MHz)
Below 1.705	30
1.705 – 108	1000
108 – 500	2000
500 – 1000	5000
Above 1000	5 <sup>th</sup> harmonic of the highest frequency or 40 C whichever is lower

Spectrum Parameter	Setting
Attenuation	Auto
Start Frequency	1000 MHz
Stop Frequency	10th carrier harmonic
RBW / VBW setting	1 MHz / 1 MHz for Peak, 1 MHz / 10Hz for Average

Receiver Parameter	Setting
Attenuation	Auto
Start ~ Stop Frequency	9kHz~150kHz / RB 200Hz for QP
Start ~ Stop Frequency	150kHz~30MHz / RB 9kHz for QP
Start ~ Stop Frequency	30MHz~1000MHz / RB 120kHz for QP

**TEST PROCEDURE**

- a. The measuring distance of at 3 m shall be used for measurements at frequency up to 1GHz. For frequencies above 1GHz, any suitable measuring distance may be used.
- b. The EUT was placed on the top of a rotating table 0.8 meters above the ground at a 3 meter open area test site. The table was rotated 360 degrees to determine the position of the highest radiation.
- c. The height of the equipment or of the substitution antenna shall be 0.8 m; above 1GHz, the height was 1.5m, the height of the test antenna shall vary between 1 m to 4 m. Both horizontal and vertical polarizations of the antenna are set to make the measurement.
- d. The initial step in collecting conducted emission data is a spectrum analyzer peak detector mode pre-scanning the measurement frequency range. Significant peaks are then marked and then Quasi Peak detector mode re-measured.
- e. If the Peak Mode measured value compliance with and lower than Quasi Peak Mode Limit, the EUT shall be deemed to meet QP Limits and then no additional QP Mode measurement performed.
- f. For the actual test configuration, please refer to the related Item –EUT Test Photos.

Note:

Both horizontal and vertical antenna polarities were tested and performed pretest to three orthogonal axis. The worst case was X axis and the emissions were reported

### TEST SETUP

(A) Radiated Emission Test-Up Frequency Below 30MHz

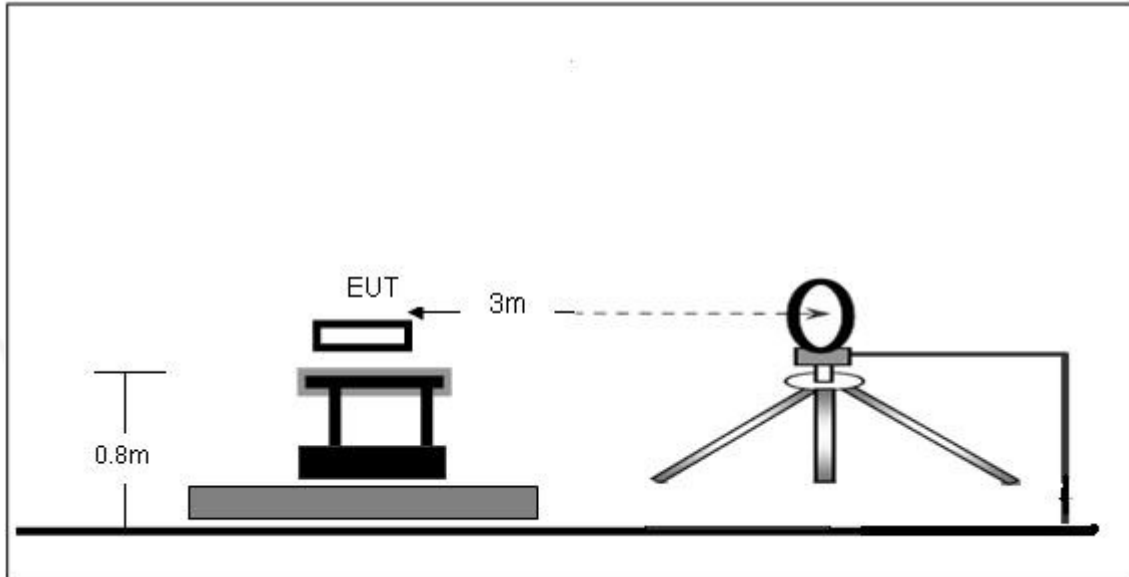

(B) Radiated Emission Test-Up Frequency 30MHz~1GHz

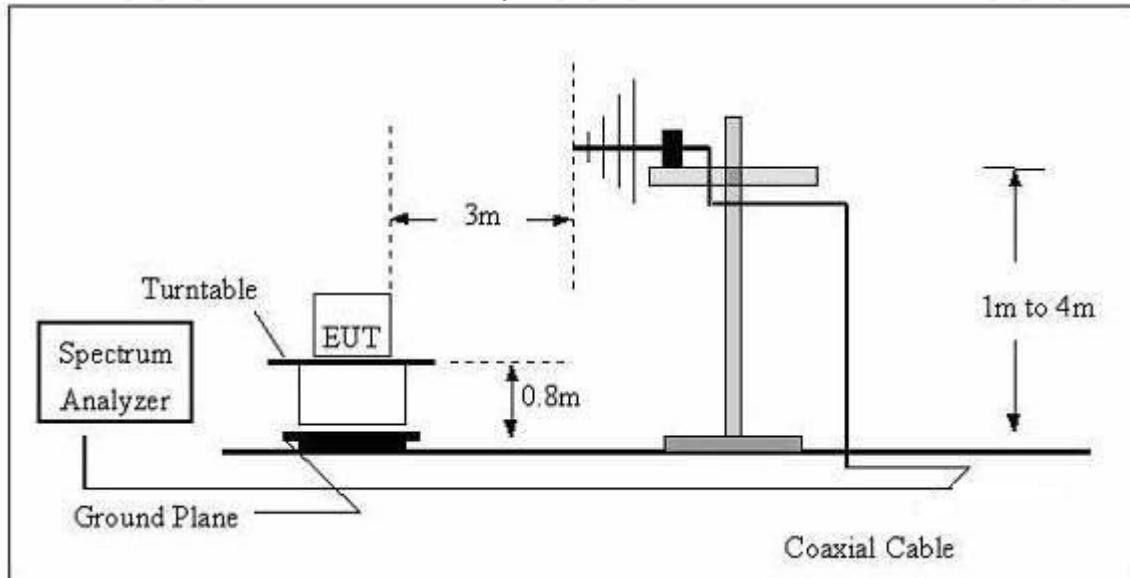

(C) Radiated Emission Test-Up Frequency Above 1GHz

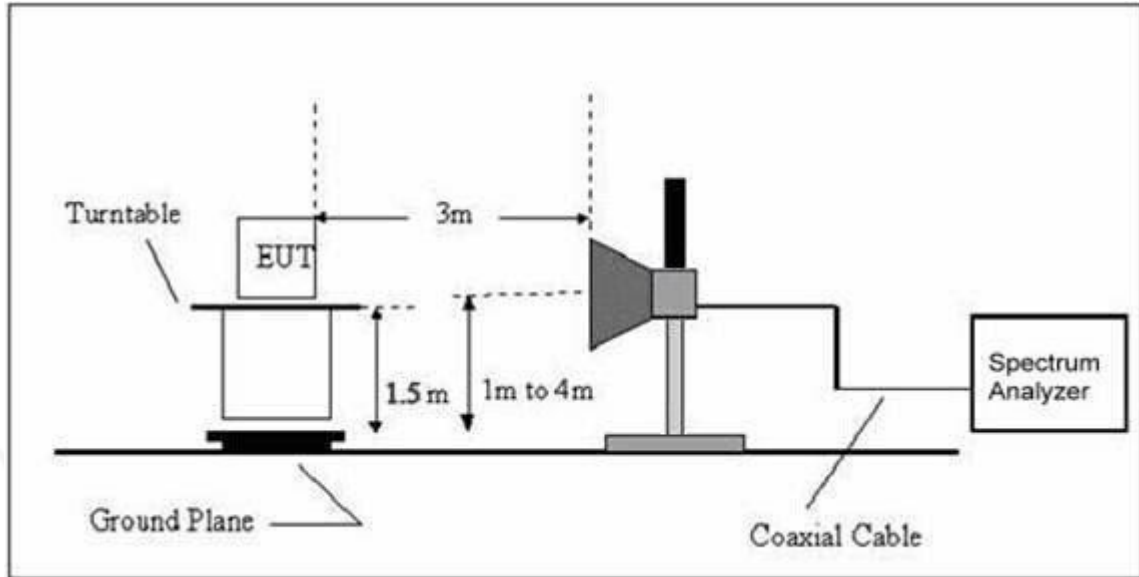

**EUT OPERATING CONDITIONS**

The EUT tested system was configured as the statements of 2.4 Unless otherwise a special operating condition is specified in the follows during the testing.

**TEST RESULTS**

## Radiated Spurious Emission (Below 30MHz )

Temperature :	26 °C	Relative Humidity :	54%
Pressure :	1010 hPa	Polarization :	---
Test Voltage :	DC 3V battery		
Test Mode :	TX Mode		

Freq. (MHz)	Reading (dBuV/m)	Limit (dBuV/m)	Margin (dB)	State P/F
--	--	--	--	PASS
--	--	--	--	PASS

**NOTE:**

The amplitude of spurious emissions which are attenuated by more than 20dB below the permissible value has no need to be reported.

Distance extrapolation factor =  $40 \log(\text{specific distance}/\text{test distance})$ (dB);

Limit line = specific limits(dBuv) + distance extrapolation factor.



Radiated Spurious Emission (Between 30MHz – 1GHz)

Temperature :	26 °C	Relative Humidity :	54%
Pressure :	1010 hPa	Polarization :	Horizontal
Test Voltage :	DC 3V battery		
Test Mode :	TX Mode		

Frequency (MHz)	Meter Reading (dBµV)	Factor (dB)	Emission Level (dBµV/m)	Limits (dBµV/m)	Margin (dB)	Detector Type
216.7828	40.36	-15.57	24.79	46.00	-21.21	QP
325.5958	52.32	-11.42	40.90	46.00	-5.10	QP
433.9200	82.82	-8.60	74.22	100.80	-26.58	PK
597.2234	36.66	-4.57	32.09	46.00	-13.91	QP
651.9417	36.86	-3.78	33.08	46.00	-12.92	QP
867.8400	53.64	0.13	53.77	80.80	-27.03	PK

Remark:

Factor = Antenna Factor + Correct Factor.  
 Correct Factor= Cable Loss – Pre-amplifier

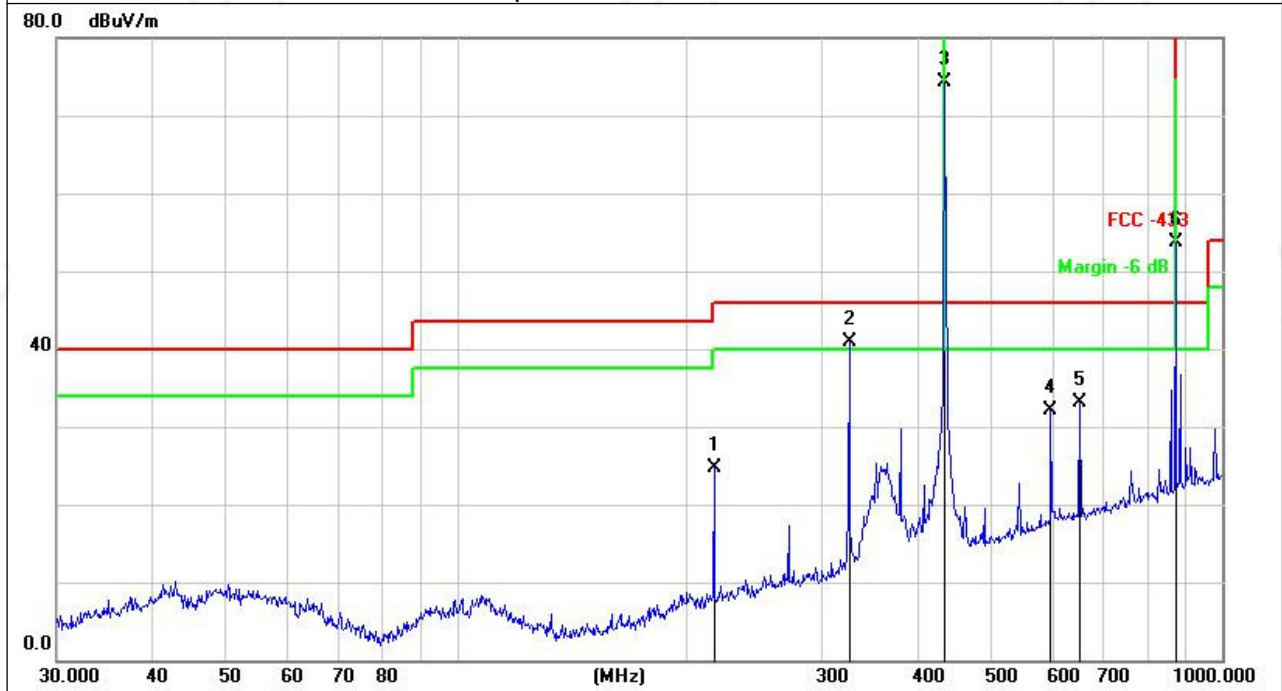



Temperature :	26 °C	Relative Humidity :	54%
Pressure :	1010 hPa	Polarization :	Vertical
Test Voltage :	DC 3V battery		
Test Mode :	TX Mode		

Frequency (MHz)	Meter Reading (dBμV)	Factor (dB)	Emission Level (dBμV/m)	Limits (dBμV/m)	Margin (dB)	Detector Type
72.8466	31.94	-19.92	12.02	40.00	-27.98	QP
216.7828	28.08	-15.57	12.51	46.00	-33.49	QP
325.5958	35.94	-11.42	24.52	46.00	-21.48	QP
433.9200	66.16	-8.60	57.56	100.80	-43.46	PK
867.8400	44.20	0.13	44.33	80.80	-36.50	PK
912.8620	32.67	0.85	33.52	46.00	-12.48	QP

Remark:

Factor = Antenna Factor + Correct Factor.  
 Correct Factor= Cable Loss – Pre-amplifier

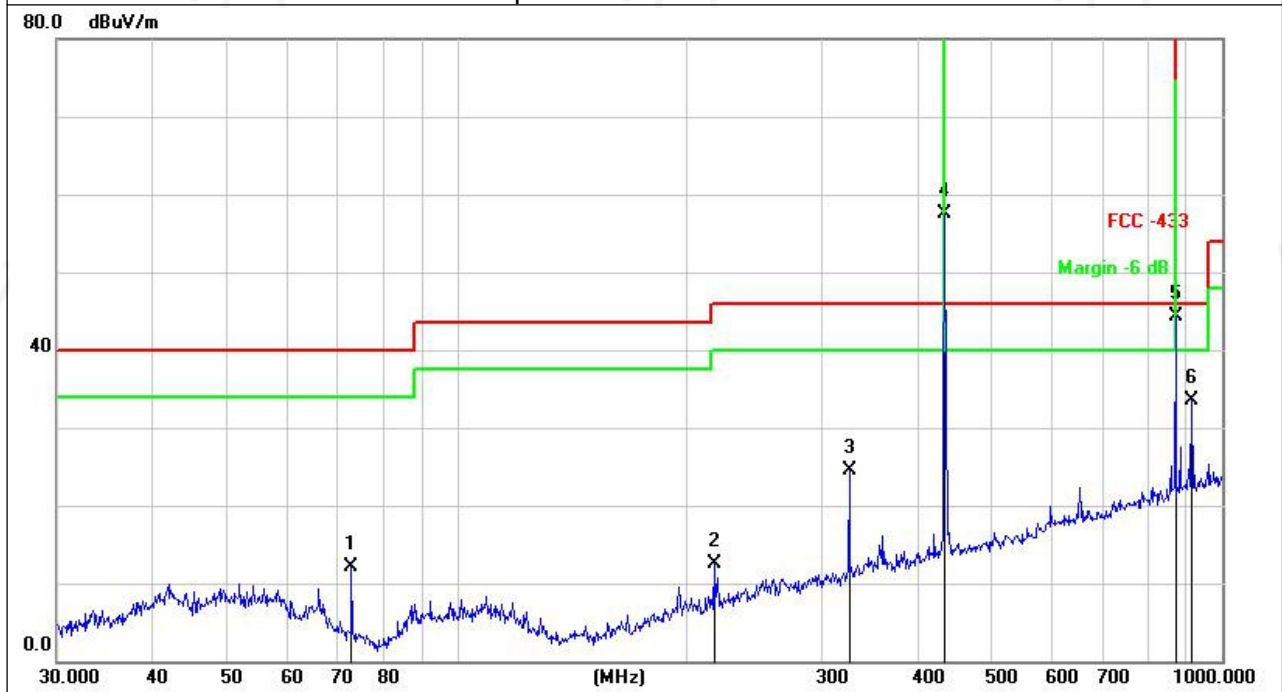



For average Emission

Frequency MHz	Peak Level dBuV/m	Duty cycle factor	AverageLevel dBuV/m	Limit AV	Margin	Polarization
433.92	57.56	-10.54	47.02	80.80	-33.78	Vertical
867.84	44.33	-10.54	33.79	60.80	-27.01	Vertical

Notes: 1. Average emission Level = Peak Level + Duty cycle factor  
2. Duty cycle level please see clause 5.

Frequency MHz	Peak Level dBuV/m	Duty cycle factor	AverageLevel dBuV/m	Limit AV	Margin	Polarization
433.92	74.22	-10.54	63.68	80.80	-17.12	Horizontal
867.84	53.77	-10.54	43.23	60.80	-17.57	Horizontal

Notes: 1. Average emission Level = Peak Level + Duty cycle factor  
2. Duty cycle level please see clause 5.



Radiated Spurious Emission ( 1GHz to 10<sup>th</sup> harmonics)

Frequency MHz	Peak Level dBuV/m	Duty cycle factor	Average Level dBuV/m	Limit		Margin dB		Polarization
				PK	AV	PK	AV	
1312.72	49.93	-10.54	39.39	80.80	60.80	-30.87	-21.41	Horizontal
1745.68	59.32	-10.54	48.78	80.80	60.80	-21.48	-12.02	Horizontal
2127.53	61.64	-10.54	51.10	80.80	60.80	-19.16	-9.70	Horizontal
2675.25	56.43	-10.54	45.89	80.80	60.80	-24.37	-14.91	Horizontal
3036.05	55.55	-10.54	45.01	80.80	60.80	-25.25	-15.79	Horizontal
3434.57	55.55	-10.54	45.01	80.80	60.80	-25.25	-15.79	Horizontal
1312.72	45.51	-10.54	34.97	80.80	60.80	-35.29	-25.83	Vertical
1745.68	54.57	-10.54	44.03	80.80	60.80	-26.23	-16.77	Vertical
2127.53	47.71	-10.54	37.17	80.80	60.80	-33.09	-23.63	Vertical
2675.25	57.93	-10.54	47.39	80.80	60.80	-22.87	-13.41	Vertical
3036.05	51.74	-10.54	41.20	80.80	60.80	-29.06	-19.60	Vertical
3434.57	48.57	-10.54	38.03	80.80	60.80	-32.23	-22.77	Vertical

Notes: 1.Average emission Level = Peak Level + Duty cycle factor

2.Duty cycle level please see clause 5.

3. Pulse Desensitization Correction Factor

Pulse Width (PW) = 16.25ms

$2/PW = 2/16.25ms = 0.123kHz$

RBW (100 kHz) > 2/PW (0.123kHz)

Therefore PDCF is not needed

4.Other harmonics emissions are lower than 20dB below the allowable limit.



## . BANDWIDTH TEST

### APPLIED PROCEDURES / LIMIT

According to FCC 15.231(c) requirement:

The bandwidth of the emission shall be no wider than 0.25% of the center frequency for devices operating between 70 MHz to 900 MHz. Those devices operating above 900 MHz, the emission spurious shall be no wider than 0.5% of the center frequency. Bandwidth is determined at the points 20 dB down from the modulated carrier.

$$B.W (20dBc) \text{ Limit} = 0.25\% * f(\text{MHz}) = 0.25\% * 433.92\text{MHz} = 1.0848\text{MHz}$$

Spectrum Parameter	Setting
Attenuation	Auto
Span Frequency	> Measurement Bandwidth or Channel Separation
RB	100kHz
VB	$\geq$ RBW
Detector	Peak
Trace	Max Hold
Sweep Time	Auto

### TEST PROCEDURE

- The EUT was directly connected to the spectrum analyzer and antenna output port as show in the block diagram below,
- Spectrum Setting : RBW= 100kHz, VBW $\geq$  RBW, Sweep time = Auto.

### DEVIATION FROM STANDARD

No deviation.

### TEST SETUP



### EUT OPERATION CONDITIONS

The EUT tested system was configured as the statements of 2.4 Unless otherwise a special operating condition is specified in the follows during the testing.



### TEST RESULTS

Temperature :	25 °C	Relative Humidity :	54%
Pressure :	1012 hPa	Test Voltage :	DC 3V
Test Mode :	TX Mode		

Frequency	20dB Bandwidth (kHz)	99% Bandwidth (kHz)	Limit (kHz)	Result
433.92MHz	1025	1213.1	1084.8	PASS

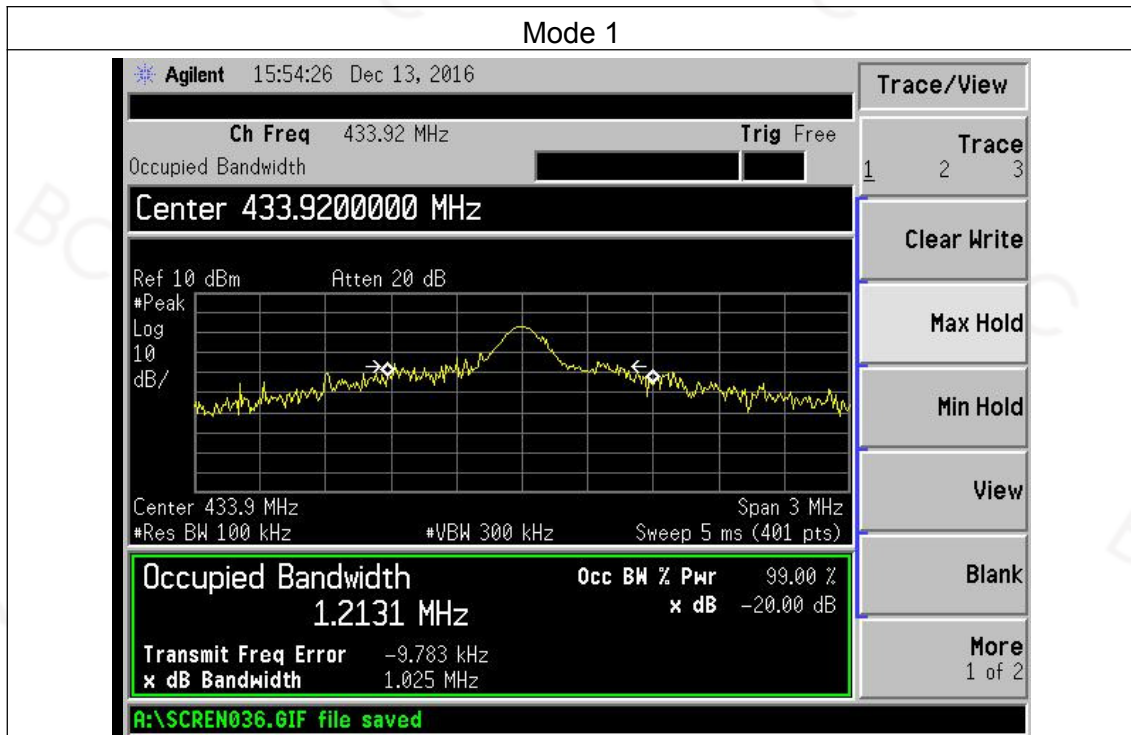



### . CALCULATION OF AVERAGE FACTOR

The output field strengths of specification in accordance with the FCC rules specify measurements with an average detector. During the test, a spectrum analyzer incorporating a peak detector was used. Therefore, a reduction factor can be applied to the resultant peak signal level and compared to the limit for measurement instrumentation incorporating an average detector.

The duty cycle is measured in 100 ms or the repetition cycle period, whichever is a shorter time frame. The duty cycle is measured by placing the spectrum analyzer to set zero span at 100kHz resolution bandwidth.

Averaging factor in dB =  $20\log(\text{duty cycle})$

The duration of one cycle = 54.75ms

The duty cycle is simply the on-time divided the duration of one cycle

$$\text{Duty Cycle} = (0.65\text{ms} \times 25) / 54.75\text{ms}$$

$$= 16.25\text{ms} / 54.75\text{ms}$$

$$= 0.297$$

Therefore, the averaging factor is found by  $20\log(0.297) = 20\log(0.297) = -10.54\text{dB}$

Test plot as follows:

Pulse

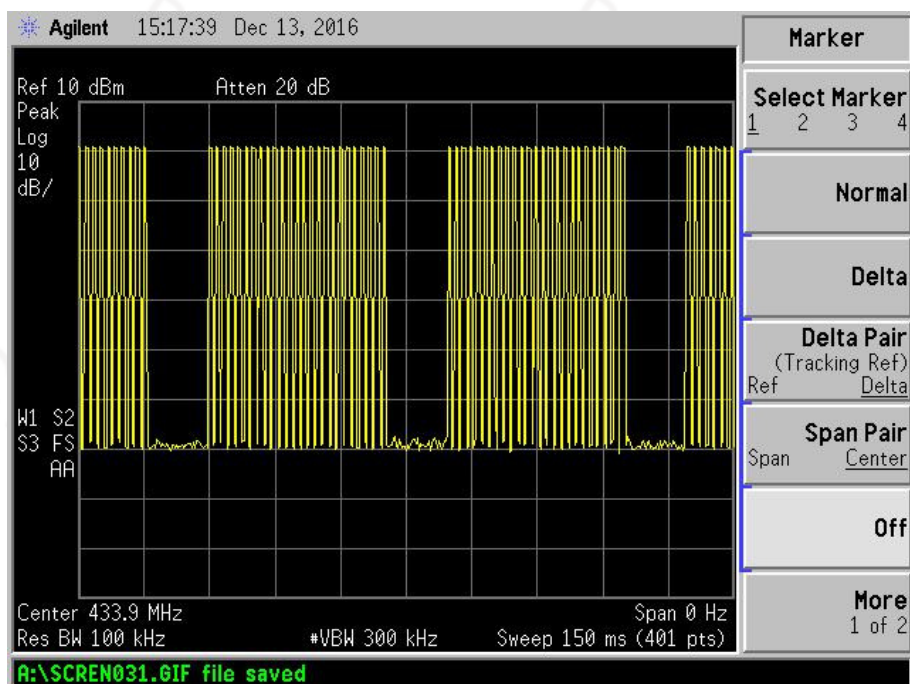



### On-time

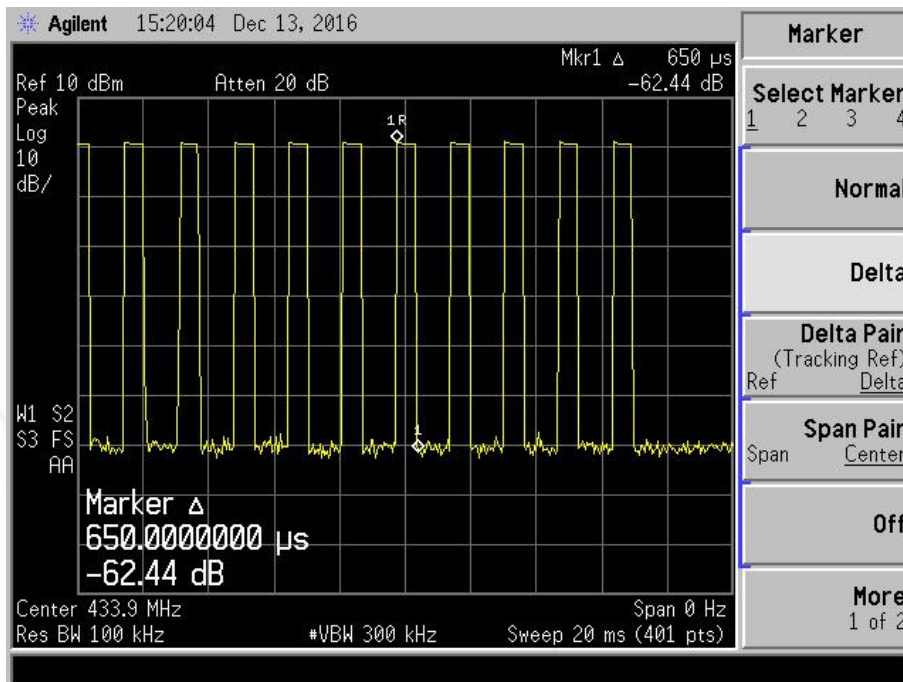
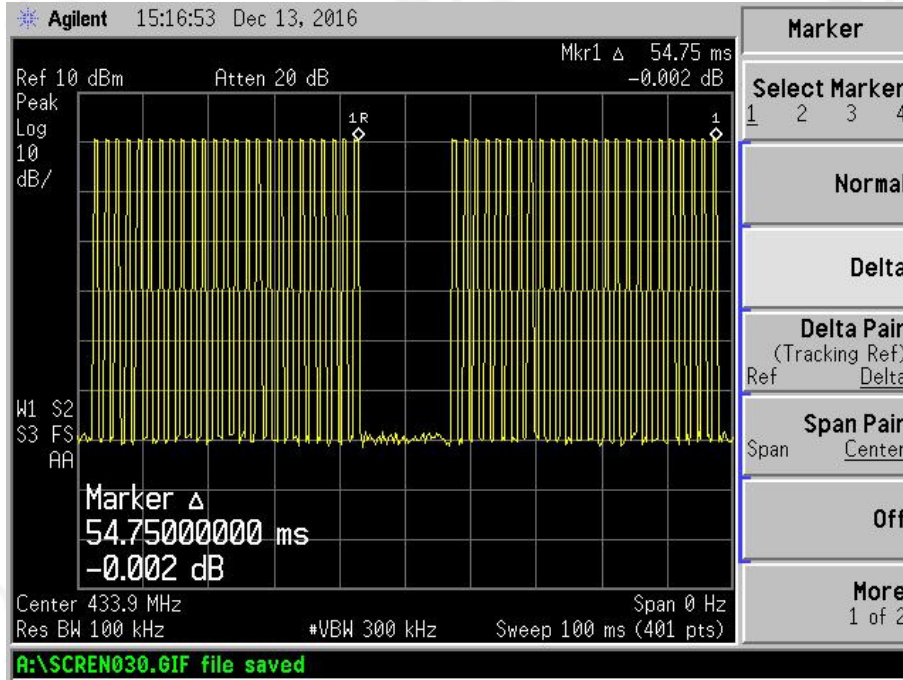



## . DWELL TIME

### APPLICABLE STANDARD

According to FCC 15.231(a) requirement:

A manually operated transmitter shall employ a switch that will automatically deactivate the transmitter within not more than 5 seconds of being released.

### TEST PROCEDURE

- a) Check the calibration of the measuring instrument using either an internal calibrator or a known signal from an external generator.
- b) Position the EUT without connection to measurement instrument. Turn on the EUT and connect its antenna terminal to measurement instrument via a low loss cable. Then set it to any one measured frequency within its operating range, and make sure the instrument is operated in its linear range.
- c) Set RBW to 100 kHz and VBW of spectrum analyzer to 300 kHz with a convenient frequency span including 100 kHz bandwidth from band edge.
- d) Measure the highest amplitude appearing on spectral display and set it as a reference level. Plot the graph with marking the highest point and edge frequency.
- e) Repeat above procedures until all measured frequencies were complete.

### DEVIATION FROM STANDARD

No deviation.

### TEST SETUP



### EUT OPERATION CONDITIONS

The EUT tested system was configured as the statements of 2.4 Unless otherwise a special operating condition is specified in the follows during the testing.



**TEST RESULTS**

Dwell time (second)	Limit (second)	Result
400ms	<5s	Pass

Test plot as follows:

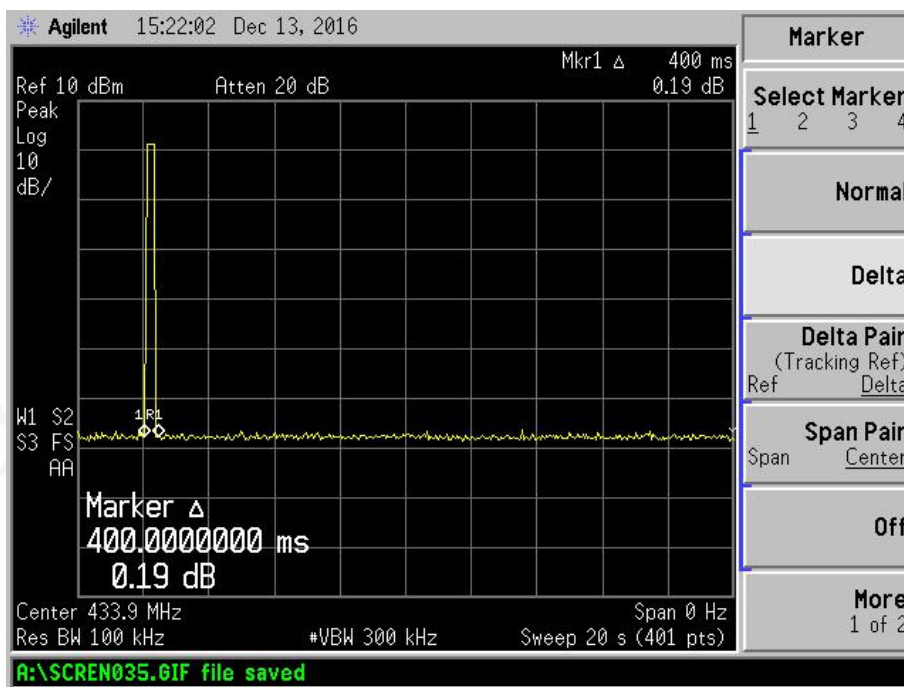



## **. ANTENNA REQUIREMENT**

### **STANDARD REQUIREMENT**

15.203 requirement: For intentional device, according to 15.203: an intentional radiator shall be designed to ensure that no antenna other than that furnished by the responsible party shall be used with the device.

### **EUT ANTENNA**

The EUT antenna is the permanent PCB antenna. It comply with the standard requirement.



. EUT TEST PHOTO

**Radiated Measurement Photos**

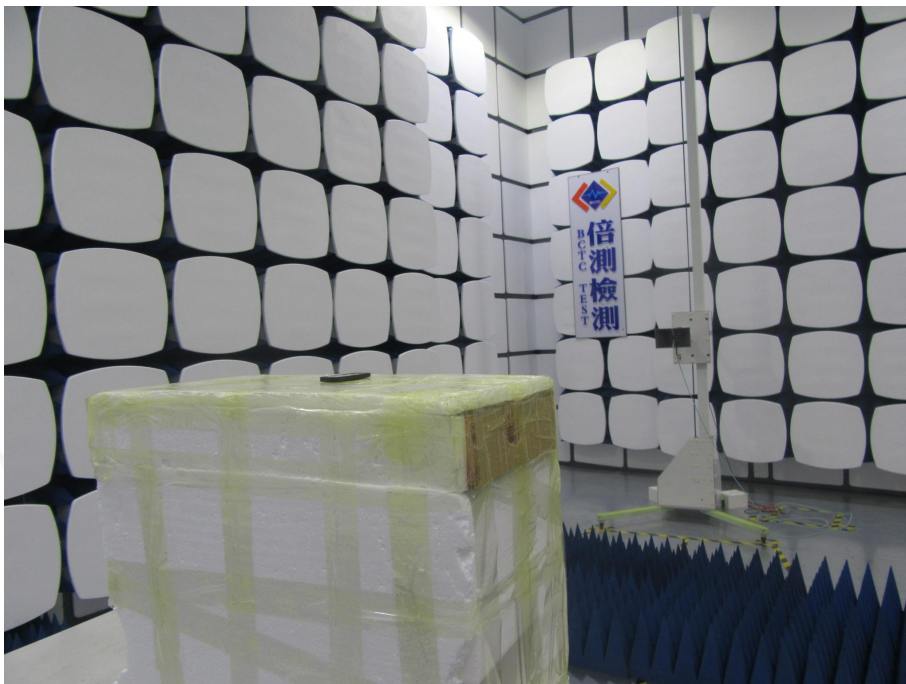
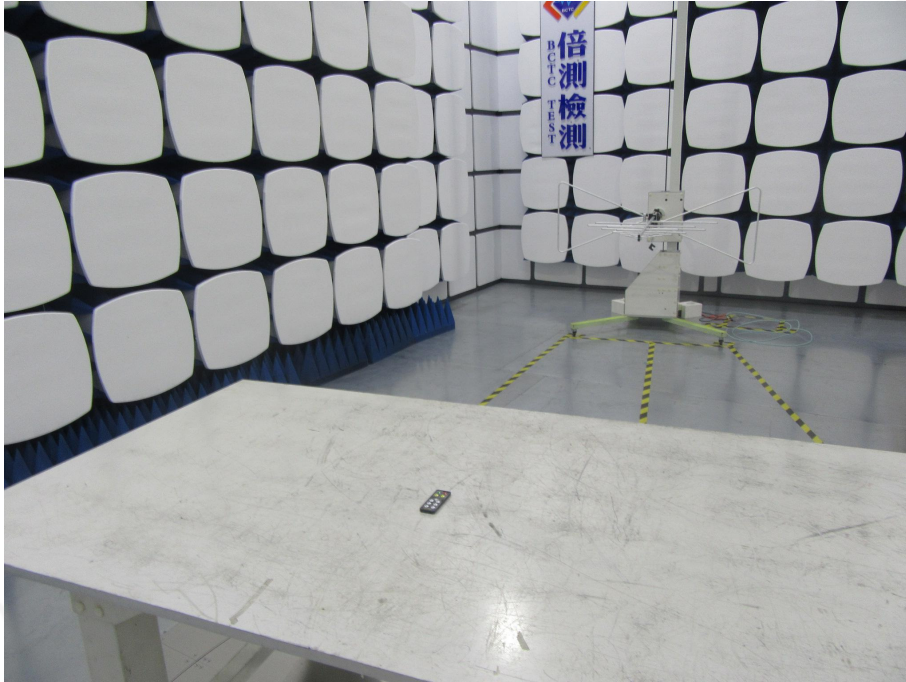



**. EUT PHOTO**



**\*\*\*\*\* END OF REPORT \*\*\*\*\***