



TESTING LABORATORY
CERTIFICATE #4820.01



FCC PART 20.21

TEST REPORT

For

Signifi Mobile Inc

1001 Rue Lenoir Suite A-414, Montreal Quebec, H4C 2Z6, Canada

FCC ID: 2AJAN-SMF13CPAL

Report Type: Original Report	Product Type: Uniden Cellular Signal Booster
Report Number: RGMA191112002-00A	
Report Date: 2019-12-10	
Reviewed By: Jerry Zhang EMC Manager	<i>Jerry Zhang</i>
Prepared By: Bay Area Compliance Laboratories Corp. (Dongguan) No.69 Pulongcun, Puxinhu Industry Area, Tangxia, Dongguan, Guangdong, China Tel: +86-769-86858888 Fax: +86-769-86858891 www.baclcorp.com.cn	

TABLE OF CONTENTS

GENERAL INFORMATION.....	4
PRODUCT DESCRIPTION FOR EQUIPMENT UNDER TEST (EUT).....	4
OBJECTIVE.....	4
RELATED SUBMITTAL(S)/GRANT(S).....	4
TEST METHODOLOGY.....	4
MEASUREMENT UNCERTAINTY.....	5
TEST FACILITY.....	5
DECLARATIONS.....	5
SYSTEM TEST CONFIGURATION.....	6
DESCRIPTION OF TEST CONFIGURATION.....	6
EUT EXERCISE SOFTWARE.....	6
SPECIAL ACCESSORIES.....	6
EQUIPMENT MODIFICATIONS.....	6
SUPPORT EQUIPMENT LIST AND DETAILS.....	7
EXTERNAL I/O CABLE.....	7
BLOCK DIAGRAM OF TEST SETUP.....	7
SUMMARY OF TEST RESULTS.....	8
TEST EQUIPMENT LIST.....	9
§ 20.21(E)(3) – AUTHORIZED FREQUENCY BAND VERIFICATION.....	11
APPLICABLE STANDARD.....	11
TEST PROCEDURE.....	11
TEST DATA.....	12
§ 20.21(e)(8)(i)(D) , § 20.21(e)(8)(i)(B)& §20.21(e)(4)– MAXIMUM POWER MEASUREMENT.....	18
APPLICABLE STANDARD.....	18
TEST PROCEDURE.....	18
TEST DATA.....	19
§ 20.21(e)(8)(i)(C)(2), § 20.21(e)(8)(i)(B)&§20.21(e)(4) – MAXIMUM BOOSTER GIAN COMPUTATION	22
APPLICABLE STANDARDS.....	22
TEST PROCEDURE.....	22
TEST DATA.....	22
§ 20.21(e)(8)(i)(F)- INTERMODULATION PRODUCT.....	24
APPLICABLE STANDARDS.....	24
TEST PROCEDURE.....	24
TEST DATA.....	25
§ 20.21(e)(8)(i)(E)- OUT OF BAND EMISSIONS.....	36
APPLICABLE STANDARDS.....	36
TEST PROCEDURE.....	36
TEST DATA.....	37
§ 20.21(e)(8)(i)(A), § 20.21(e)(8)(i)(H) &§20.21(e)(4) - NOISE LIMITS.....	98
APPLICABLE STANDARDS.....	98
TEST PROCEDURE.....	98
TEST DATA.....	99
§ 20.21(e)(8)(i)(I) &§20.21(e)(4) - UPLINK INACTIVITY.....	110

APPLICABLE STANDARDS.....	110
TEST PROCEDURE	110
TEST DATA	111
§ 20.21(e)(8)(i)(C)(1) & § 20.21(e)(8)(i)(H) - VARIABLE BOOSTER GAIN.....	115
APPLICABLE STANDARDS.....	115
TEST PROCEDURE	115
TEST DATA	116
§ 2.1049 - OCCUPIED BANDWIDTH	122
APPLICABLE STANDARDS.....	122
TEST PROCEDURE	122
TEST DATA	123
§ 20.21(e)(8)(ii)(A) & §20.21(e)(4) - OSCILLATION DETECTION	154
APPLICABLE STANDARDS.....	154
TEST PROCEDURE	154
TEST DATA	154
§2.1051- SPURIOUS EMISSIONS AT ANTENNA TERMINALS	169
APPLICABLE STANDARDS.....	169
TEST PROCEDURE	169
TEST DATA	170
§ 2.1053 - RADIATED SPURIOUS EMISSIONS	191
APPLICABLE STANDARDS.....	191
TEST PROCEDURE	191
TEST DATA	192

GENERAL INFORMATION

Product Description for Equipment under Test (EUT)

EUT Name:		Uniden Cellular Signal Booster
Equipment Type:		Fixed Wideband Consumer Signal Booster
EUT Tested Model:		SM-F13CPAL
Multiple Models:		SM-F10CPAL, SM-CW33CPAL, SM-C33CPAL
Rated Input Voltage:		12V DC from adapter
Adapter Information	Model:	GM50-120300-F
	Input:	AC 100-240V, 50/60Hz, 1.5A
	Output:	DC 12V 3.0A
Serial Number:		19112002
EUT Received Date:		2019-11-12
EUT Received Status:		Good

Notes: Model SM-F13CPAL was selected for fully testing, the detailed information about the difference among SM-F10CPAL, SM-CW33CPAL, SM-C33CPAL and model SM-F13CPAL can be referred to the declaration letter which was stated and guaranteed by the manufacturer.

Bands	Uplink Frequency (MHz)	Downlink Frequency (MHz)
Lower 700	698-716	728-746
Upper 700	776-787	746-757
Cellular	824-849	869-894
AWS	1710-1755	2110-2155
PCS	1850-1915	1930-1995

Objective

This test report is prepared on behalf of *Signifi Mobile Inc* in accordance with Part 2, part 20.21, part 22, part 24 and Part 27 of the Federal Communication Commissions rules.

Related Submittal(s)/Grant(s)

No related submittal.

Test Methodology

All tests and measurements indicated in this document were performed in accordance with the Code of federal Regulations Title 47 Part 2, Sub-part J as well as the following individual parts:

Applicable Standards: TIA 603-D, KDB 935210 D03 Signal Booster Measurements v04r03.

All emissions measurement was performed at Bay Area Compliance Laboratories Corp. (Dongguan). The radiated testing was performed at an antenna-to-EUT distance of 3 meters.

Measurement Uncertainty

Item		Uncertainty
RF conducted test with spectrum		±0.9dB
Radiated emission	30MHz~1GHz	±5.91dB
	Above 1G	±4.92dB
Occupied Bandwidth		±0.5kHz
Temperature		±1.0°C
Humidity		±6%

Note: Otherwise required by the applicant or Product Regulations, Decision Rule in this report did not consider the uncertainty. The extended uncertainty given in this report is obtained by combining the standard uncertainty times the coverage factor K with the 95% confidence interval.

Test Facility

The Test site used by Bay Area Compliance Laboratories Corp. (Dongguan) to collect test data is located on the No.69 Pulongcun, Puxinhu Industry Area, Tangxia, Dongguan, Guangdong, China.

The lab has been recognized as the FCC accredited lab under the KDB 974614 D01 and is listed in the FCC Public Access Link (PAL) database, FCC Registration No. : 897218, the FCC Designation No. : CN1220.

The lab has been recognized by Innovation, Science and Economic Development Canada to test to Canadian radio equipment requirements, the CAB identifier : CN0022.

Declarations

BACL is not responsible for the authenticity of any test data provided by the applicant. Data included from the applicant that may affect test results are marked with a triangle symbol “△”. Customer model name, addresses, names, trademarks etc. are not considered data.

Unless otherwise stated the results shown in this test report refer only to the sample(s) tested.

This report cannot be reproduced except in full, without prior written approval of the Company.

This report is valid only with a valid digital signature. The digital signature may be available only under the Adobe software above version 7.0.

This report must not be used by the customer to claim product certification, approval, or endorsement by A2LA, or any agency of the U.S. Government.

This report may contain data that are not covered by the accreditation scope and shall be marked with an asterisk “★”.

SYSTEM TEST CONFIGURATION

Description of Test Configuration

The system was configured for testing in a test mode which has been done in the factory.

Antenna kitting requirement: EUT has multiple sets antenna kitting for marketing, the antenna gain for varier band were listed in user manual, fulfill the requirement of FCC Part 20.21(e)(8)(i)(G), more detail information please refer to the user manuals.

Outdoor Antenna:

Bands	Frequency (MHz)	Antenna Gain (dBi)		Cable Loss (dB)
		Log Period Antenna	Panel Antenna	
Lower 700	698-716	9.5	7	1.7
Upper 700	776-787	9.5	7	1.7
Celluler	824-849	9.5	7	1.7
AWS	1710-1755	10	9	2.7
PCS	1850-1915	10	9	2.7

Indoor Antenna:

Bands	Frequency (MHz)	Antenna Gain (dBi)		Cable Loss (dB)
		Omni Antenna	Panel Antenna	
Lower 700	728-746	3	7	0.8
Upper 700	746-757	3	7	0.8
Celluler	869-894	3	7	0.8
AWS	2110-2155	3	9	1.4
PCS	1930-1995	3	9	1.4

EUT Exercise Software

No exercise software was used.

Special Accessories

No special accessory was used.

Equipment Modifications

No modification was made to the EUT tested.

Support Equipment List and Details

Manufacturer	Description	Model	Serial Number
E-Microwave	Coaxial Attenuators	EMCA40-200SN-6	OE01201046
Unknown	Load	Unknown	Unknown
Agilent	MXG Vector Signal Generator	N5182B	MY51350188

External I/O Cable

Cable Description	Shielding Type	Ferrite Core	Length (m)	From Port	To
Coaxial Cable	Yes	No	1.0	Signal Generator	EUT
Adapter Cable	No	No	1.0	Adapter	EUT

Block Diagram of Test Setup

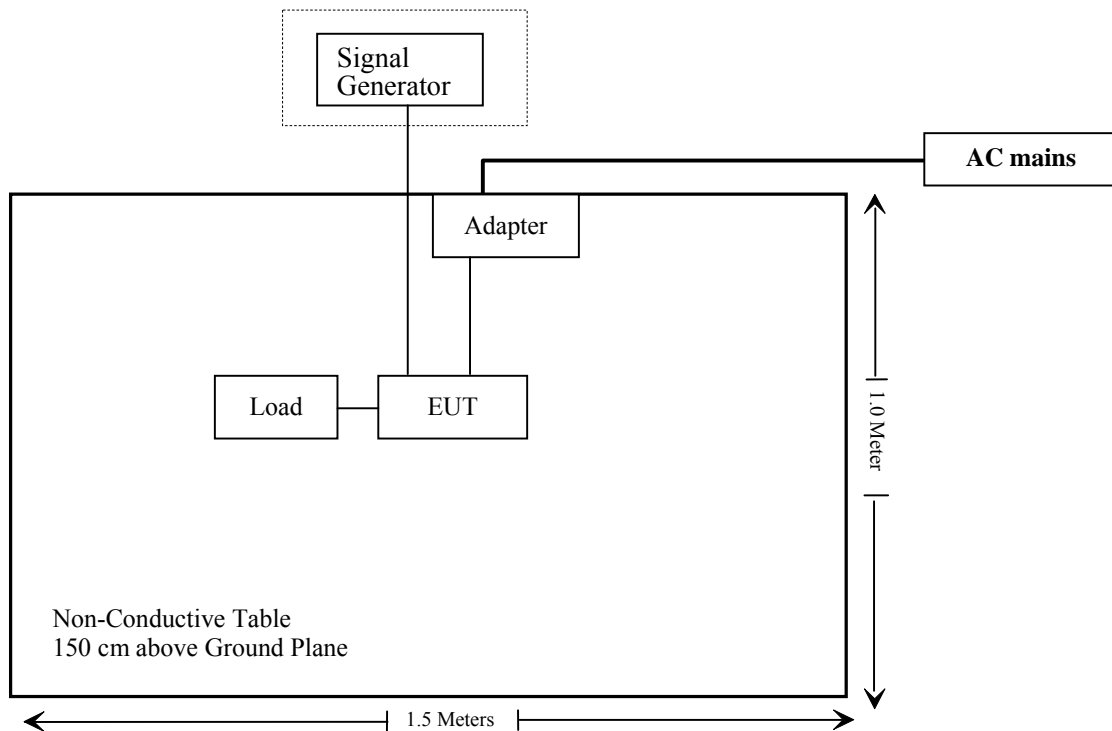

SUMMARY OF TEST RESULTS

FCC Rules	Description of Test	Results
§20.21(e)(3)	7.1 Authorized Frequency Band Verification	Compliance
§20.21(e)(8)(i)(D) §20.21(e)(8)(i)(B) & §20.21(e)(4)	7.2 Maximum Power Measurement	Compliance
§20.21(e)(8)(i)(C)(2) §20.21(e)(8)(i)(B) & §20.21(e)(4)	7.9 Maximum Booster Gain Computation	Compliance
§20.21(e)(8)(i)(B) §20.21(e)(3)	7.13 Spectrum block filtering test procedure	Not applicable
§20.21(e)(8)(i)(F)	7.4 Intermodulation Product	Compliance
§20.21(e)(8)(i)(E)	7.5 Out Of Band Emissions	Compliance
§20.21(e)(8)(i)(A) §20.21(e)(8)(i)(H) &§20.21(e)(4)	7.7 Noise Limits	Compliance
§20.21(e)(8)(i)(I) &§20.21(e)(4)	7.8 Uplink Inactivity	Compliance
§20.21(e)(8)(i)(C)(1) & §20.21(e)(8)(i)(H)	7.9 Variable Booster Gain	Compliance
§2.1049	7.10 Occupied Bandwidth	Compliance
§20.21(e)(8)(ii)(A) &§20.21(e)(4)	7.11 Oscillation Detection	Compliance
§2.1051	7.6 Spurious Emissions At Antenna Terminals	Compliance
§ 2.1053	7.12 Radiated Spurious Emissions	Compliance

Not applicable: This item only for wideband consumer boosters utilizing spectrum block filtering.

TEST EQUIPMENT LIST

Manufacturer	Description	Model	Serial Number	Calibration Date	Calibration Due Date
Radiated Emission Test					
R&S	EMI Test Receiver	ESR3	102453	2019-09-12	2020-09-12
EMCO	Adjustable Dipole Antenna	3121C	9109-753	N/A	N/A
Sunol Sciences	Antenna	JB3	A060611-1	2017-11-10	2020-11-10
Unknown	Coaxial Cable	C-NJNJ-50	C-0400-01	2019-09-05	2020-09-05
Unknown	Coaxial Cable	C-NJNJ-50	C-0075-01	2019-09-05	2020-09-05
Unknown	Coaxial Cable	C-NJNJ-50	C-1400-01	2019-05-06	2020-05-06
HP	Amplifier	8447D	2727A05902	2019-09-05	2020-09-05
Agilent	Signal Generator	E8247C	MY43321350	2018-12-11	2019-12-11
Agilent	Spectrum Analyzer	E4440A	SG43360054	2019-05-09	2020-05-09
TDK RF	Horn Antenna	HRN-0118	130 084	2018-10-12	2021-10-12
ETS-Lindgren	Horn Antenna	3115	000 527 35	2018-10-12	2021-10-12
Unknown	Coaxial Cable	C-SJSJ-50	C-0800-01	2019-09-05	2020-09-05
Unknown	Coaxial Cable	C-NJNJ-50	C-0200-02	2019-09-05	2020-09-05
MITEQ	Amplifier	AFS42-00101800-25-S-42	2001271	2019-09-05	2020-09-05
Ducommun Technologies	Horn Antenna	ARH-4223-02	1007726-01 1304	2017-11-18	2019-11-18
Ducommun Technologies	Horn Antenna	ARH-4223-02	1007726-02 1304	2017-11-18	2019-11-18
Quinstar	Amplifier	QLW-18405536-JO	15964001001	2019-06-27	2020-06-27
RF Conducted test					
Rohde & Schwarz	Signal Analyzer	FSIQ26	831929/005	2019-08-03	2020-08-03
Unknown	Coaxial Cable	C-SJ00-0010	C0010/01	Each time	/
Unknown	Coaxial Cable	C-SJ00-0010	C0010/02	Each time	/
Unknown	Coaxial Cable	C-SJ00-0010	C0010/03	Each time	/
Unknown	Coaxial Cable	C-SJ00-0010	C0010/04	Each time	/
Unknown	Coaxial Cable	C-SJ00-0010	C0010/05	Each time	/
E-Microwave	Coaxial Attenuators	EMCA10-5RN-6	OE01203239	Each time	/
R&S	Wideband Radio Communication Tester	CMW500	147473	2019-08-03	2020-08-03
HP	Setp Attenuator	8494B	1510A05007	2019-09-05	2020-09-05
Agilent	Setp Attenuator	8496B	2815A10904	2019-09-05	2020-09-05
Unknown	Combiner	Unknown	Combiner 1	Each time	/

Unknown	Combiner	Unknown	Combiner 2	Each time	/
E-Microwave	Coaxial Attenuators	EMCA10-5RN-6	OE01203239	Each time	/
Narda	Directional coupler	4242-10	C1	Each time	/
Narda	Directional coupler	4242-10	C2	Each time	/
Narda	Directional coupler	4243B-10	C3	Each time	/
Narda	Directional coupler	4243B-10	C4	Each time	/
Agilent	MXG Vector Signal Generator	N5182B	MY51350142	2019-05-04	2020-05-04

* **Statement of Traceability:** Bay Area Compliance Laboratories Corp. (Dongguan) attests that all calibrations have been performed, traceable to National Primary Standards and International System of Units (SI).

§ 20.21(E)(3) – AUTHORIZED FREQUENCY BAND VERIFICATION

Applicable Standard

According to § 20.21(e)(3) Frequency Bands

This test is intended to confirm that the signal booster only operates on the CMRS frequency bands authorized for use by the NPS. In addition, this test will identify the frequency at which the maximum gain is realized within each CMRS operational band, which then serves as a basis for subsequent tests.

Test Procedure

- a) Connect the EUT to the test equipment as shown in Figure 1. Begin with the uplink output connected to the spectrum analyzer.
- b) Set the spectrum analyzer RBW for 100 kHz with the VBW $\geq 3 \times$ the RBW using a PEAK detector with the MAX HOLD function.
- c) Set the center frequency of the spectrum analyzer to the center of the operational band under test with a span of 1 MHz.
- d) Set the signal generator for CW mode and tune to the center frequency of the operational band under test.
- e) Set the initial signal generator power to a level that is at least 6 dB below the AGC level specified by the manufacturer.
- f) Slowly increase the signal generator power level until the output signal reaches the AGC operational level.
- g) Reduce the signal generator power to a level that is 3 dB below the level noted above and manually reset the EUT.
- h) Reset the spectrum analyzer span to $2 \times$ the CMRS band under test. Adjust the tuned frequency of the signal generator to sweep $2 \times$ the CMRS band using the sweep function. The AGC must not be activated throughout the entire sweep.
- i) Using three markers, identify the CMRS band edges and the frequency with the highest power. Affirm that the values of all markers are visible on the display of the spectrum analyzer (e.g., marker table set to on).
- j) Capture the spectrum analyzer trace for inclusion in the test report.
- k) Repeat 7.1c) to 7.1j) for all operational uplink and downlink bands.

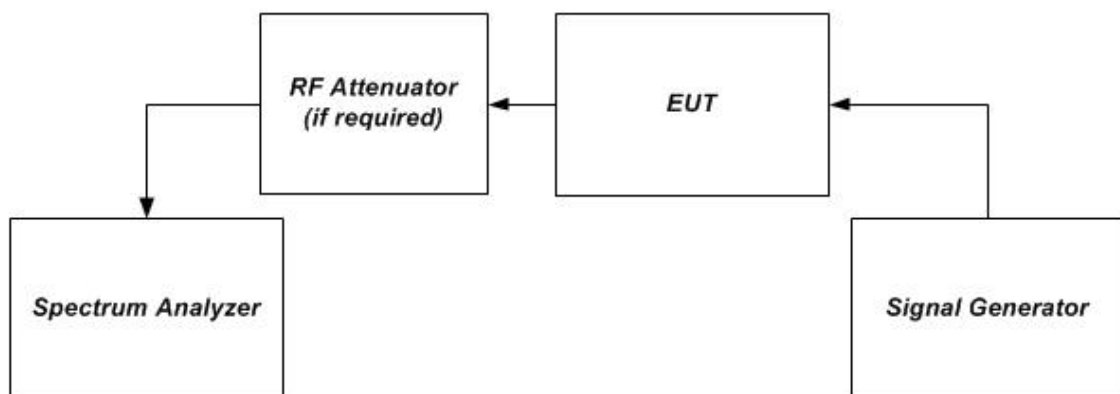

Figure 1 – Band verification test instrumentation setup

Test Data

Environmental Conditions

Temperature:	26.4~26.5 °C
Relative Humidity:	49~61 %
ATM Pressure:	100.5 kPa

The testing was performed by Blake Yang on 2019-11-25 and 2019-11-26.

Test Result: Compliance. Please refer to following plots.

Uplink:

Lower 700MHz Band

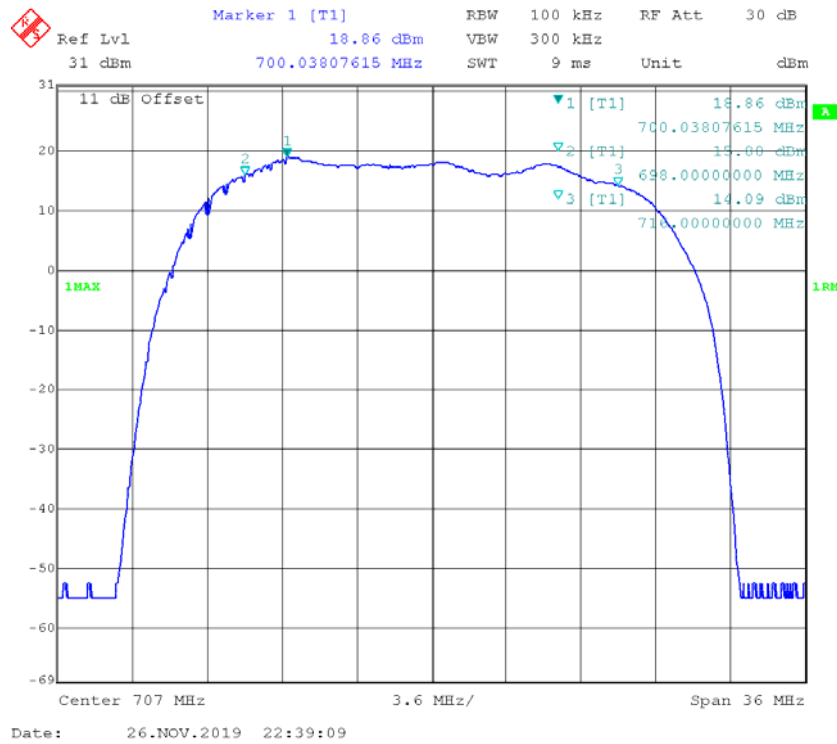

Upper 700MHz Band

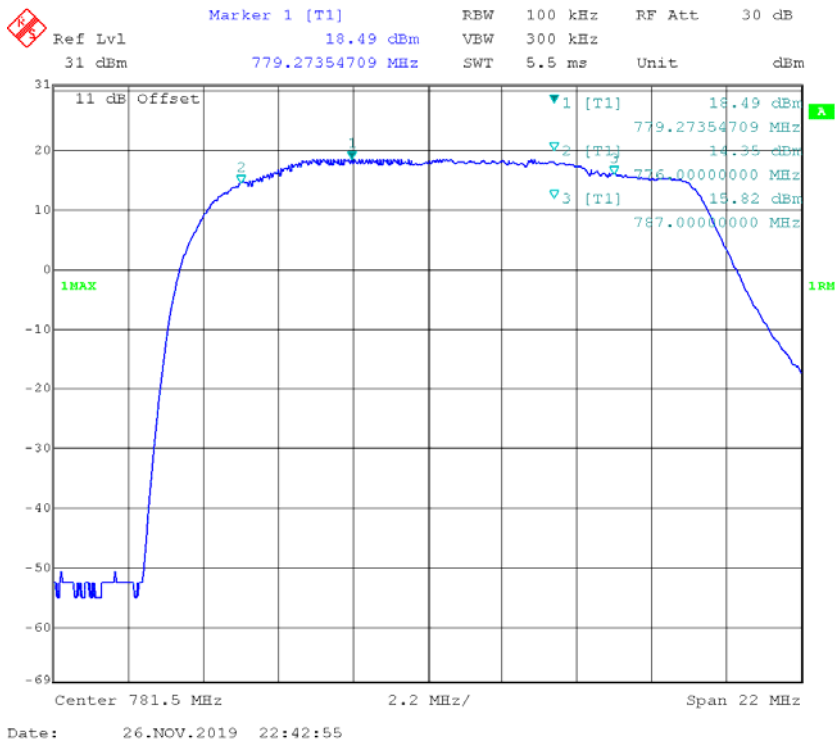

Cellular Band

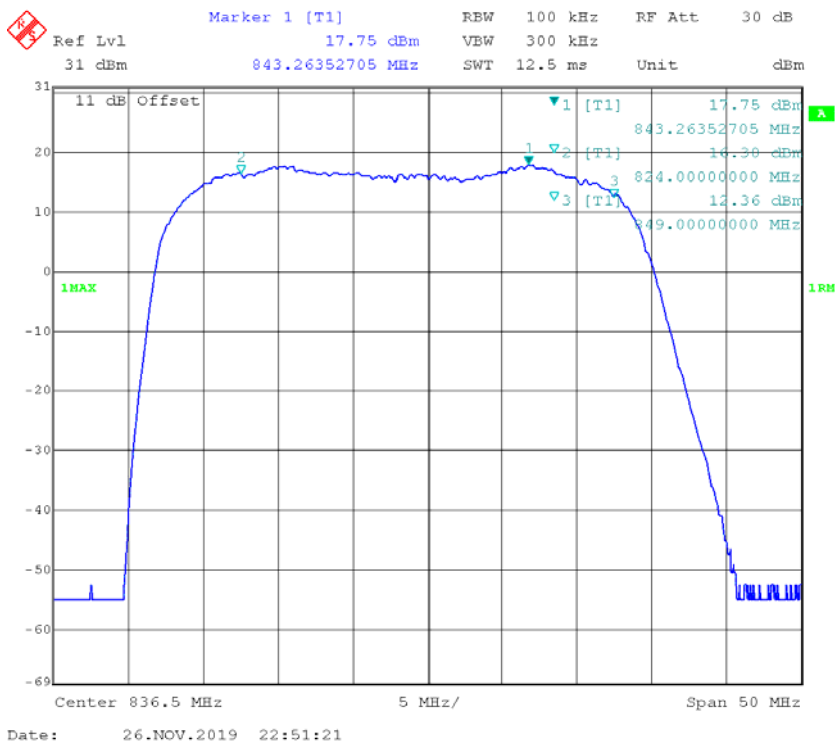

AWS Band

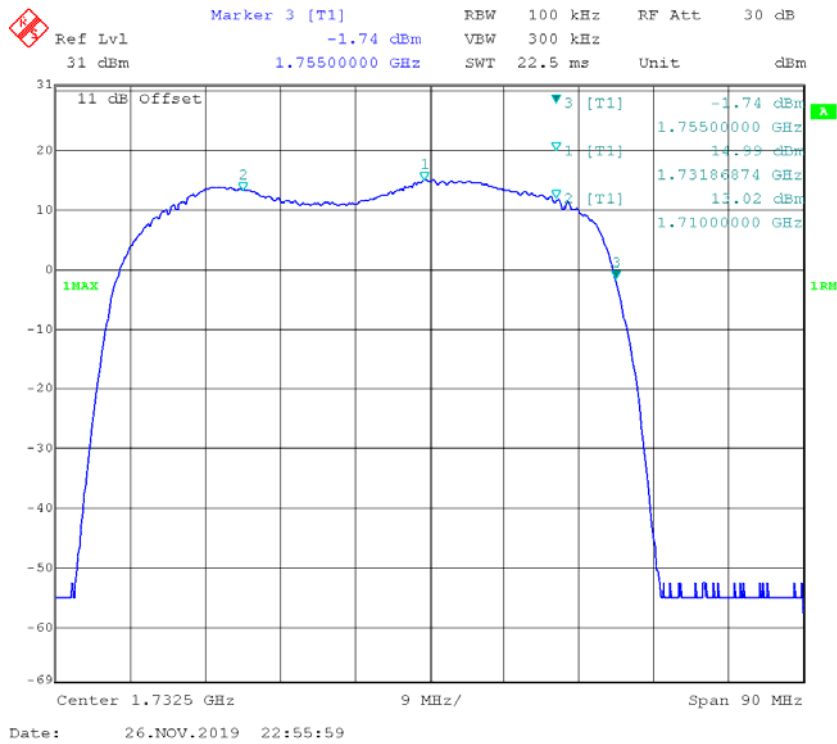

PCS Band

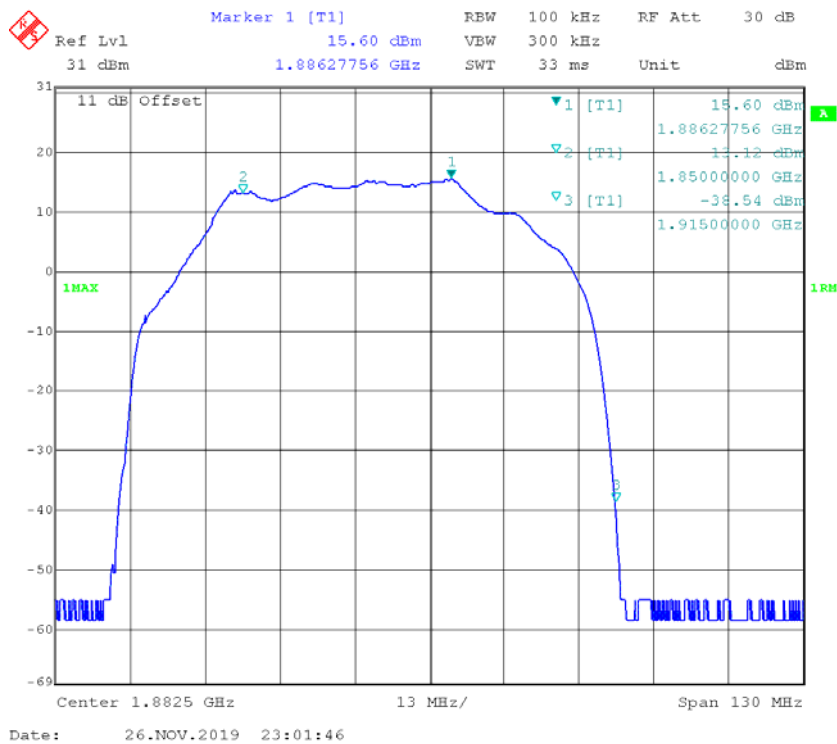

Downlink:

Lower 700MHz Band

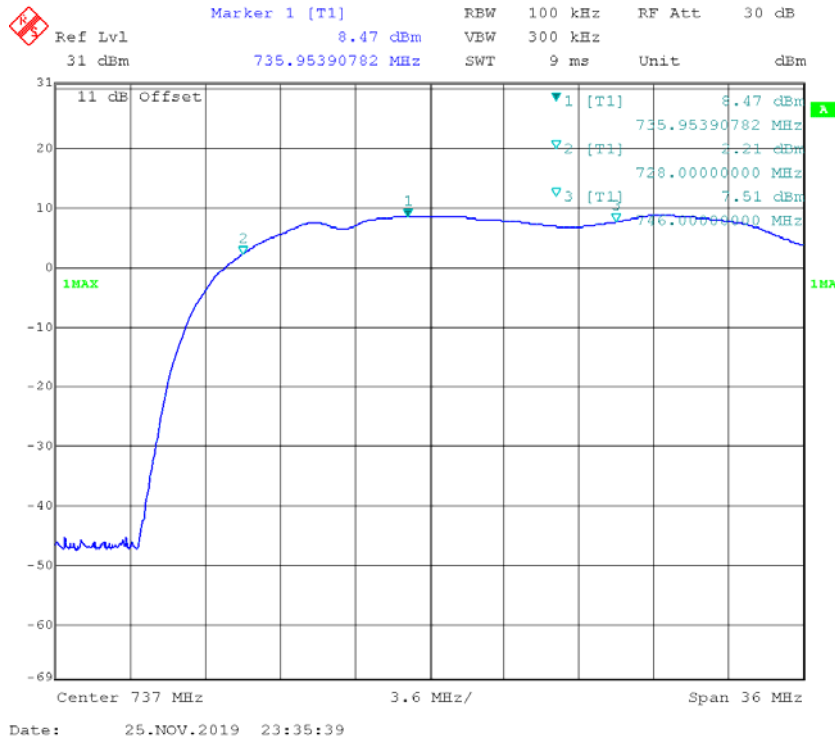

Upper 700MHz Band

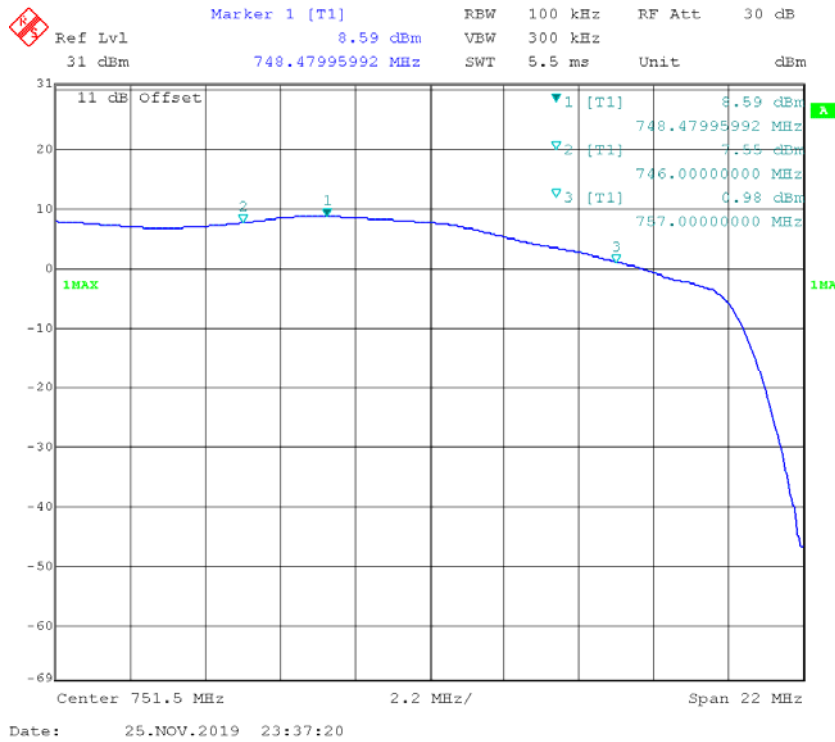

Cellular Band

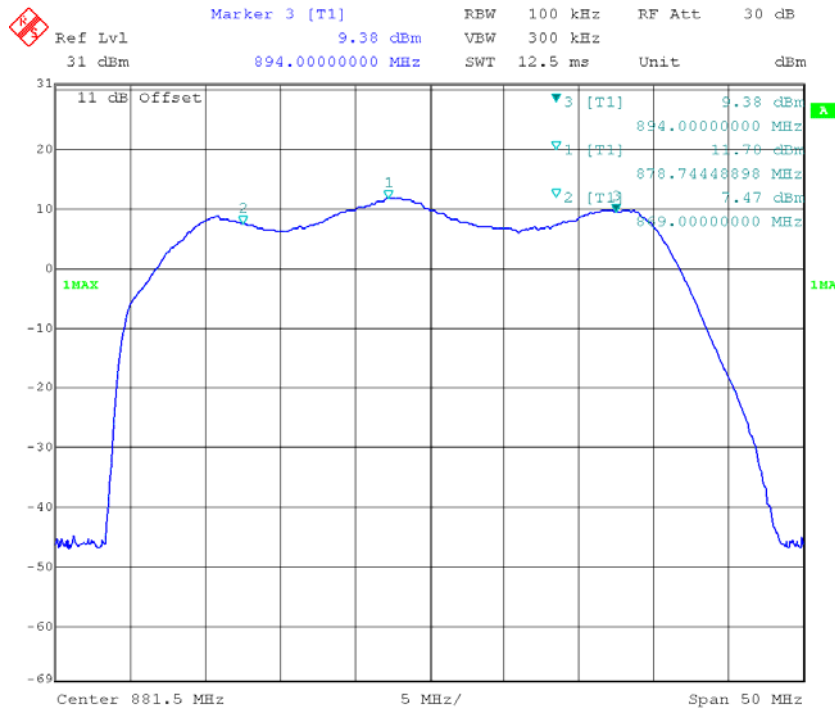

AWS Band

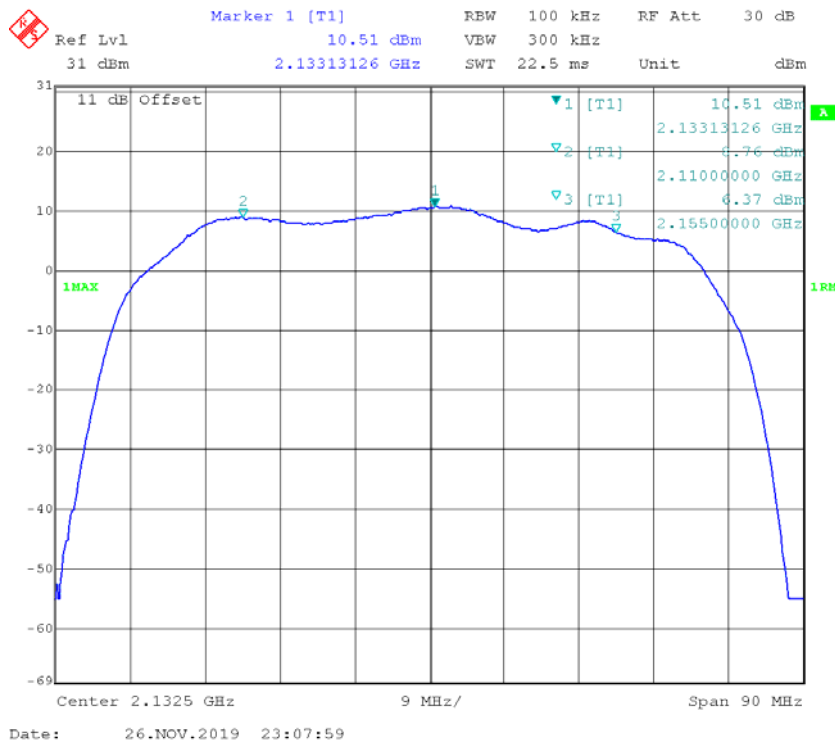

PCS Band

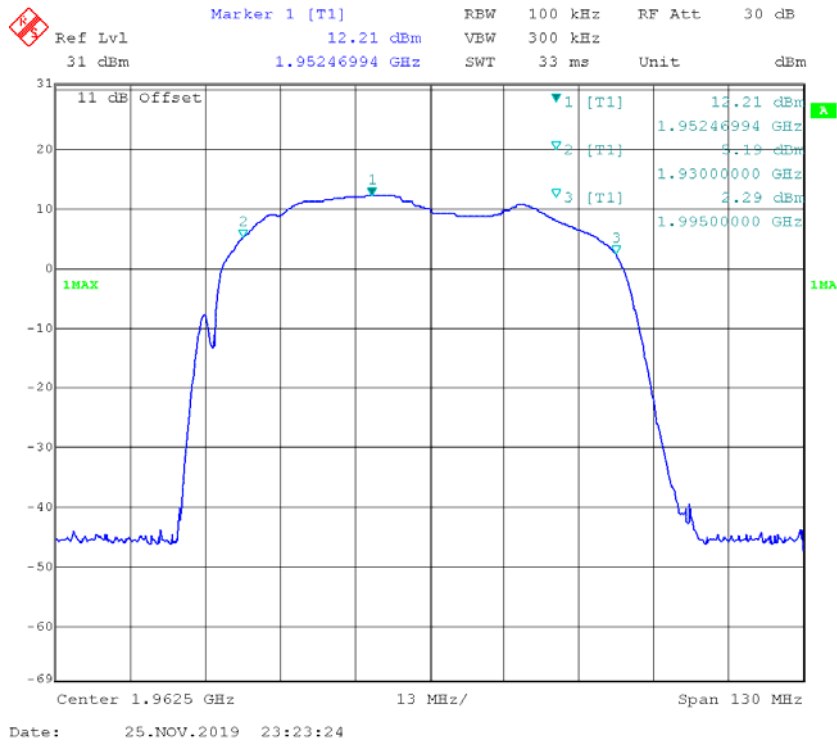

§ 20.21(e)(8)(i)(D) ,§ 20.21(e)(8)(i)(B)& §20.21(e)(4)– MAXIMUM POWER MEASUREMENT

Applicable Standard

According to § 20.21(e)(8)(i)(D) Power Limits; § 20.21(e)(8)(i)(B) Bidirectional Capability (uplink minimum conducted power output); §20.21(e)(4) Self-monitoring.

This procedure shall be used to demonstrate compliance to the signal booster power limits and requirements as specified in §§ 20.21(e)(8)(i)(D) and 20.21(e)(8)(i)(B) for wideband consumer signal boosters.

- a) Compliance to authorized EIRP limits must be shown using the highest gains from the list of antennas, cabling, and coupling devices declared by the manufacturer for use with the consumer booster.
- b) In addition, the maximum power levels measured in this procedure will be utilized in calculating the maximum gain as described in the next subclause.
- c) The frequency with the highest power level in each operational band as determined in 7.1 is to be measured discretely by applying the following procedure utilizing the stated emission and power detector types independently.
- d) Use a signal generator to create a pulsed CW or GSM signal with a pulse width of 570 μ s and a duty cycle of 12.5% (i.e., one GSM timeslot), then measure utilizing the burst power function of the measuring instrument.
- e) Use a signal generator to create an AWGN signal with a 99% occupied bandwidth of 4.1 MHz, then measure utilizing the channel power or band power function of the measuring instrumentation.
- f) All modes of operation must be verified to maintain operation within authorized limits at the maximum uplink and downlink test levels per device type as defined in 5.4, by increasing the power level in 2 dB steps from the AGC level to the maximum input level specified in 5.5.

Test Procedure

- a) Connect the EUT to the test equipment as shown in Figure 1. Begin with the uplink output (donor port) connected to the spectrum analyzer.
- b) Configure the signal generator and spectrum analyzer for operation on the frequency determined in 7.1 with the highest power level, but with the center frequency of the signal no closer than 2.5 MHz from the band edge. The spectrum analyzer span shall be set to at least 10 MHz.
- c) Set the initial signal generator power to a level well below that which causes AGC control.
- d) Slowly increase the signal generator power level until the output signal reaches the AGC operational limit (from observation of signal behavior on the spectrum analyzer; i.e., no further increase in output power as input power is increased).
- e) Reduce power sufficiently on the signal generator to ensure that the AGC is not controlling the power output.
- f) Slowly increase the signal generator power to a level just below (within 0.5 dB of) the AGC limit without triggering the AGC. Note the signal generator power level as P_{in} .
- g) Measure the output power P_{out} with the spectrum analyzer as follows.
 - 1) Set RBW = 100 kHz for AWGN signal type and 300 kHz for CW or GSM signal type.
 - 2) Set VBW $\geq 3 \times$ RBW.
 - 3) Select either the BURST POWER or CHANNEL POWER measurement tool, as required for each signal type. The channel power integration bandwidth shall be 99% occupied bandwidth (4.1 MHz).
 - 4) Select the RMS (power averaging) detector.
 - 5) Ensure that the number Note: This requirement
 - 6) Set sweep time = auto

- 7) Trace average at least 100 traces in power averaging (i.e., RMS) mode.
- h) Record the measured power level as P_{OUT} with one set of results for the GSM or CW input stimulus and another set of results for the AWGN input stimulus.
- i) Repeat step h) while increasing the signal generator amplitude in 2 dB steps until the maximum input level indicated in 5.5 is reached. If the booster has shut down at any point during the input power steps it should be noted and step h) shall be repeated at an input level 1 dB less than that found to cause the shutdown.
- j) Repeat the entire procedure for each operational uplink and downlink frequency band supported by the booster.
- k) Provide tabulated results in the test report.

Test Data

Environmental Conditions

Temperature:	25.9 °C
Relative Humidity:	42 %
ATM Pressure:	101.2 kPa

The testing was performed by Blake Yang on 2019-11-27.

Test Result: Compliance. Please refer to the following tables and plots

AGC Level:

Mode	Operation Band	Signal type	Pre AGC Input level	
			dBm	
Uplink	Lower 700MHz	AWGN	-40.02	
		GSM	-38.34	
	Upper 700MHz	AWGN	-39.12	
		GSM	-37.63	
	Cellular	AWGN	-38.42	
		GSM	-37.00	
	AWS	AWGN	-39.12	
		GSM	-38.31	
	PCS	AWGN	-39.21	
		GSM	-38.23	
	Downlink	Lower 700MHz	AWGN	-46.54
			GSM	-44.65
Upper 700MHz		AWGN	-47.45	
		GSM	-46.09	
Cellular		AWGN	-48.47	
		GSM	-46.23	
AWS		AWGN	-49.35	
		GSM	-48.12	
PCS		AWGN	-50.34	
		GSM	-48.26	

Output Power:

Mode	Antenna	Operation Band	Signal type	Pre AGC	Conducted	Antenna	Cable	EIRP	Limit
				Input level	Output level	Gain	loss		
				dBm	dBm	dBi	dB	dBm	dBm
Uplink	Log Periodic	Lower 700	AWGN	-39.82	15.35	9.5	1.7	23.15	17-30
			GSM	-38.41	19.56	9.5	1.7	27.36	
		Upper 700	AWGN	-40.11	15.48	9.5	1.7	23.28	
			GSM	-38.75	19.07	9.5	1.7	26.87	
		Cellular	AWGN	-38.74	17.6	9.5	1.7	25.4	
			GSM	-37.04	19.61	9.5	1.7	27.41	
		AWS	AWGN	-39.25	15.94	10	2.7	23.24	
			GSM	-37.68	17.45	10	2.7	24.75	
	PCS	AWGN	-40.43	14.45	10	2.7	21.75		
		GSM	-38.96	18.01	10	2.7	25.31		
	Panel	Lower 700	AWGN	-39.82	15.35	7	1.7	20.65	
			GSM	-38.41	19.56	7	1.7	24.86	
		Upper 700	AWGN	-40.11	15.48	7	1.7	20.78	
			GSM	-38.75	19.07	7	1.7	24.37	
		Cellular	AWGN	-38.74	17.6	7	1.7	22.9	
			GSM	-37.04	19.61	7	1.7	24.91	
AWS		AWGN	-39.25	15.94	9	2.7	22.24		
		GSM	-37.68	17.45	9	2.7	23.75		
PCS	AWGN	-40.43	14.45	9	2.7	20.75			
	GSM	-38.96	18.01	9	2.7	24.31			
Downlink	Omni	Lower 700	AWGN	-50.14	6.2	3	0.8	8.4	≤17
			GSM	-48.51	7.4	3	0.8	9.6	
		Upper 700	AWGN	-50.32	4.18	3	0.8	6.38	
			GSM	-48.85	7.54	3	0.8	9.74	
		Cellular	AWGN	-48.67	5.32	3	0.8	7.52	
			GSM	-46.52	6.84	3	0.8	9.04	
		AWS	AWGN	-47.63	5.25	3	1.4	6.85	
			GSM	-46.21	7.93	3	1.4	9.53	
	PCS	AWGN	-46.85	6.87	3	1.4	8.47		
		GSM	-45.14	7.5	3	1.4	9.1		
	Panel	Lower 700	AWGN	-50.14	6.2	7	0.8	12.4	
			GSM	-48.51	7.4	7	0.8	13.6	
		Upper 700	AWGN	-50.32	4.18	7	0.8	10.38	
			GSM	-48.85	7.54	7	0.8	13.74	
		Cellular	AWGN	-48.67	5.32	7	0.8	11.52	
			GSM	-46.52	6.84	7	0.8	13.04	
AWS		AWGN	-47.63	5.25	9	1.4	12.85		
		GSM	-46.21	7.93	9	1.4	15.53		
PCS	AWGN	-46.85	6.87	9	1.4	14.47			
	GSM	-45.14	7.5	9	1.4	15.1			

Maximum Input level:

Mode	Operation Band	Signal type	Maximum Input level	Maximum Input level Limits	Conducted Output level		
			dBm	dBm	dBm		
Uplink	Lower 700	AWGN	12.5	27.0	15.94		
		GSM	14.4		19.81		
	Upper 700	AWGN	11.6		15.66		
		GSM	13.8		18.54		
	Cellular	AWGN	11.5		18.12		
		GSM	13.3		20.02		
	AWS	AWGN	10.8		16.13		
		GSM	12.1		18.25		
	PCS	AWGN	10.6		15.12		
		GSM	12.7		18.41		
	Downlink	Lower 700	AWGN		-24.6	-20	6.33
			GSM		-26.4		7.24
Upper 700		AWGN	-25.5	5.02			
		GSM	-27.2	7.68			
Cellular		AWGN	-26.8	5.76			
		GSM	-24.3	7.14			
AWS		AWGN	-27.8	5.36			
		GSM	-25.4	8.74			
PCS		AWGN	-28.7	6.65			
		GSM	-26.9	9.14			

§ 20.21(e)(8)(i)(C)(2), § 20.21(e)(8)(i)(B)&§20.21(e)(4) – MAXIMUM BOOSTER GIAN COMPUTATION

Applicable Standards

According to § 20.21(e)(8)(i)(C)(2) Booster Gain Limits (maximum gain); § 20.21(e)(8)(i)(B) Bidirectional Capability (equivalent uplink and downlink gain); §20.21(e)(4) Self-monitoring.

This subclause provides guidance on the computation of the maximum gain based on the results obtained from previous measurements. The NPS limits on maximum gain for fixed and mobile wideband consumer signal boosters are provided in § 20.21(e)(8)(i)(C)(2). Additionally, § 20.21(e)(8)(i)(B) requires that wideband consumer signal boosters be able to provide equivalent uplink and downlink gain (within 9 dB)

Test Procedure

- a) Calculate the maximum gain of the booster as follows to demonstrate compliance to the applicable gain limits as specified.
- b) For both the uplink and downlink in each supported frequency band, use each of the P_{OUT} and P_{IN} result pairs for all signal types used in 7.2 in the following equation to determine the maximum gain (G) of the booster:
 $G \text{ (dB)} = P_{OUT}(\text{dBm}) - P_{IN}(\text{dBm})$.
- c) Record the maximum gain of the uplink and downlink paths for each supported frequency band, and verify that the each gain value complies with the applicable limit.
- d) Provide tabulated results in the test report.

Test Data

Environmental Conditions

Temperature:	25.9 °C
Relative Humidity:	42 %
ATM Pressure:	101.2 kPa

The testing was performed by Blake Yang on 2019-11-27.

Test Result: Compliance. Please refer to the following tables.

Maximum gain:

Mode	Operation Band	Signal type	Pre AGC Input level	Conducted Output level	Gain	Limit	
			dBm	dBm	dB	dB	
Uplink	LOWER 700	AWGN	-39.82	15.35	55.17	63.49	
		GSM	-38.41	19.56	57.97		
	UPPER 700	AWGN	-40.11	15.48	55.59	64.36	
		GSM	-38.75	19.07	57.82		
	Cellular	AWGN	-38.74	17.60	56.34	64.95	
		GSM	-37.04	19.61	56.65		
	AWS	AWGN	-39.25	15.94	55.19	71.27	
		GSM	-37.68	17.45	55.13		
	PCS	AWGN	-40.43	14.45	54.88	71.99	
		GSM	-38.96	18.01	56.97		
	Downlink	LOWER 700	AWGN	-50.14	6.20	56.34	63.49
			GSM	-48.51	7.40	55.91	
UPPER 700		AWGN	-50.32	4.18	54.50	64.36	
		GSM	-48.85	7.54	56.39		
Cellular		AWGN	-48.67	5.32	53.99	64.95	
		GSM	-46.52	6.84	53.36		
AWS		AWGN	-47.63	5.25	52.88	71.27	
		GSM	-46.21	7.93	54.14		
PCS		AWGN	-46.85	6.87	53.72	71.99	
		GSM	-45.14	7.50	52.64		

Note: Fixed Booster maximum gain shall not exceed 6.5 dB + 20 Log₁₀ (Frequency), Where, Frequency is the uplink mid-band frequency of the supported spectrum bands in MHz.

Equivalent Uplink and downlink gain:

Operating Band	Signal type	Uplink Gain	Downlink Gain	Calculated Value	Limit
MHz		dB	dB	dB	dB
LOWER 700	AWGN	55.17	56.34	-1.17	±9
	GSM	57.97	55.91	2.06	
UPPER 700	AWGN	55.59	54.5	1.09	
	GSM	57.82	56.39	1.43	
Cellular	AWGN	56.34	53.99	2.35	
	GSM	56.65	53.36	3.29	
AWS	AWGN	55.19	52.88	2.31	
	GSM	55.13	54.14	0.99	
PCS	AWGN	54.875	53.72	1.16	
	GSM	56.97	52.64	4.33	

§ 20.21(e)(8)(i)(F)- INTERMODULATION PRODUCT

Applicable Standards

According to § 20.21(e)(8)(i)(F) Intermodulation Limits.

Test Procedure

The following procedures shall be used to demonstrate compliance to the intermodulation limit specified in § 20.21(e)(8)(i)(F) for wideband consumer signal boosters.

- a) Connect the signal booster to the test equipment as shown in **Figure 2**. Begin with the uplink output connected to the spectrum analyzer.
- b) Set the spectrum analyzer RBW = 3 kHz.
- c) Set the VBW $\geq 3 \times$ RBW.
- d) Select the RMS detector
- e) Set the spectrum analyzer center frequency to the center of the supported operational band under test.
- f) Set the span to 5 MHz. Affirm that the number of measurement points per sweep $\geq (2 \times \text{span})/\text{RBW}$.
- g) Configure the two signal generators for CW operation with generator 1 tuned 300 kHz below the operational band center frequency and generator 2 tuned 300 kHz above the operational band center frequency.
- h) Set the signal generator amplitudes so that the power from each into the RF combiner is equivalent, then turn on the RF output.
- i) Increase the signal generators' amplitudes equally until just before the EUT begins AGC and affirm that all intermodulation products (if any exist) are below the specified limit of -19 dBm.
- j) Utilize the trace averaging function of the spectrum analyzer and wait for the trace to stabilize. Place a marker at the highest amplitude intermodulation product.
- k) Record the maximum intermodulation product amplitude level that is observed.
- l) Capture the spectrum analyzer trace for inclusion in the test report.
- m) Repeat 7.4e) to 7.4l) for all uplink and downlink operational bands.

Note: *If using a single signal generator with dual outputs, affirm that intermodulation products are not the result of the generator.*

- n) Increase the signal generator amplitude in 2 dB steps to 10 dB above the AGC threshold determined in 7.4i), but to not to exceed the maximum input level in 5.5, to affirm that the EUT maintains compliance with the intermodulation limit

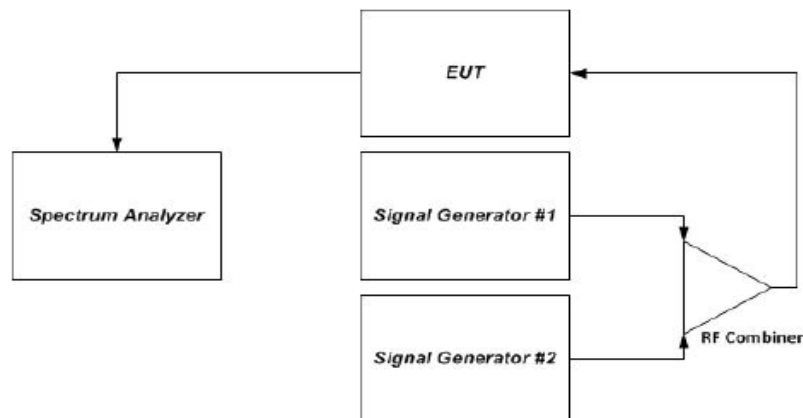

Figure 2 – Intermodulation product instrumentation test setup

Test Data

Environmental Conditions

Temperature:	26.4 °C
Relative Humidity:	61 %
ATM Pressure:	100.5 kPa

The testing was performed by Blake Yang on 2019-11-25.

Test Result: Compliance. Please refer to following plots.

Uplink:

Lower 700MHz Band Pre-AGC

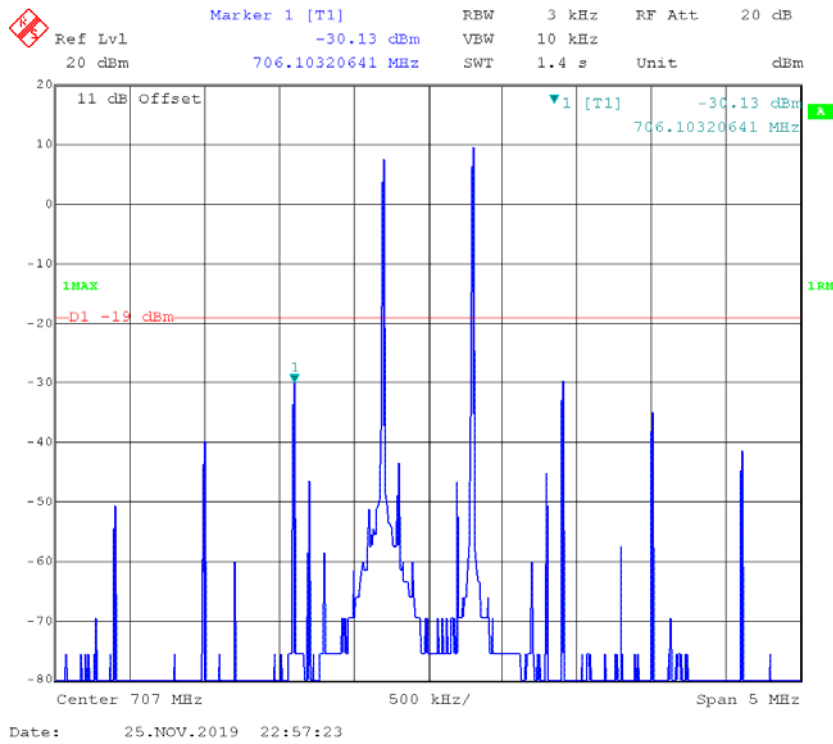

Lower 700MHz Band Above AGC

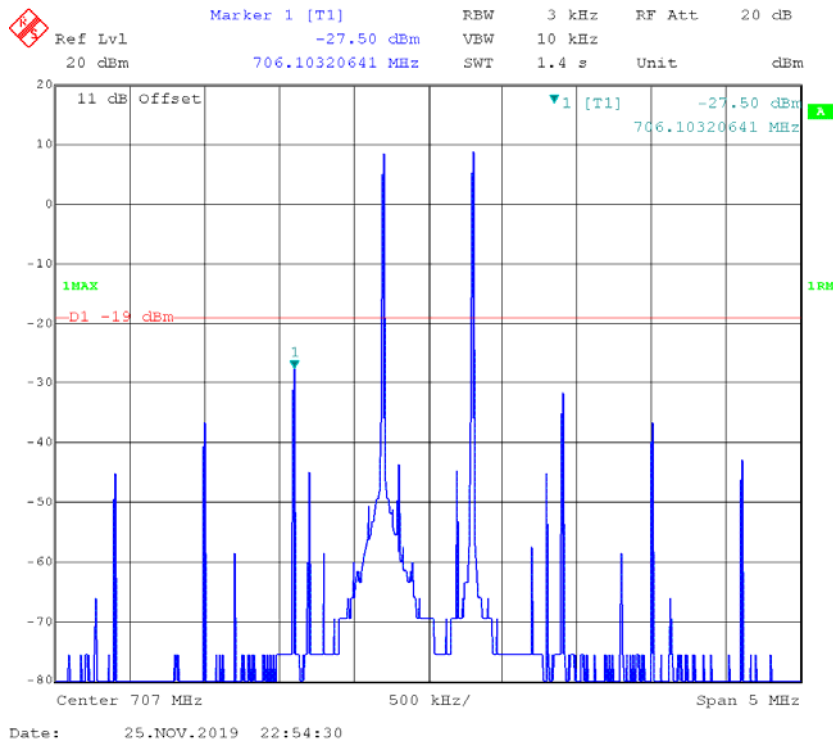

Upper 700MHz Band Pre-AGC

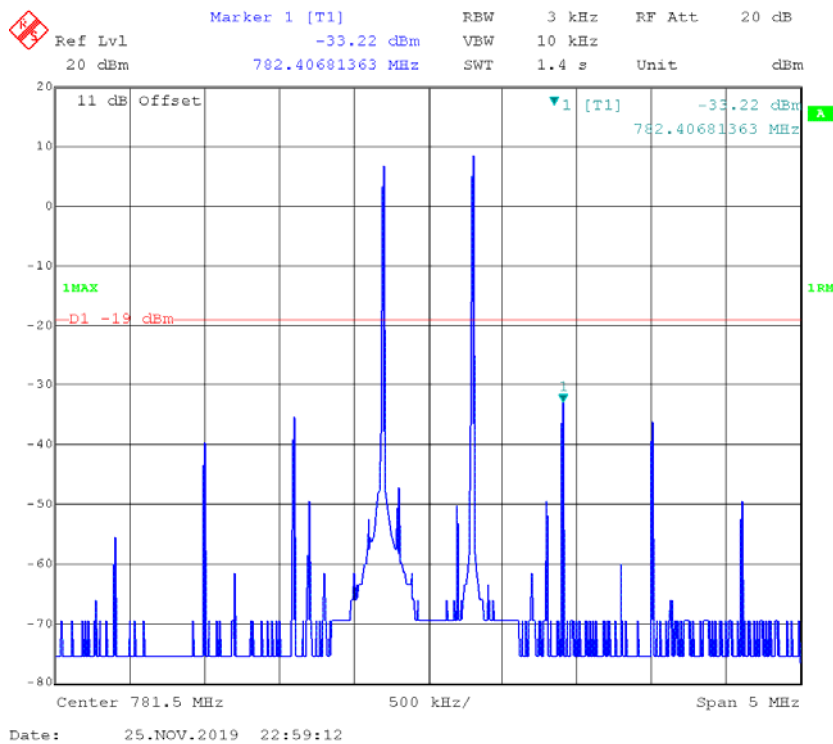

Upper 700MHz Band Above AGC

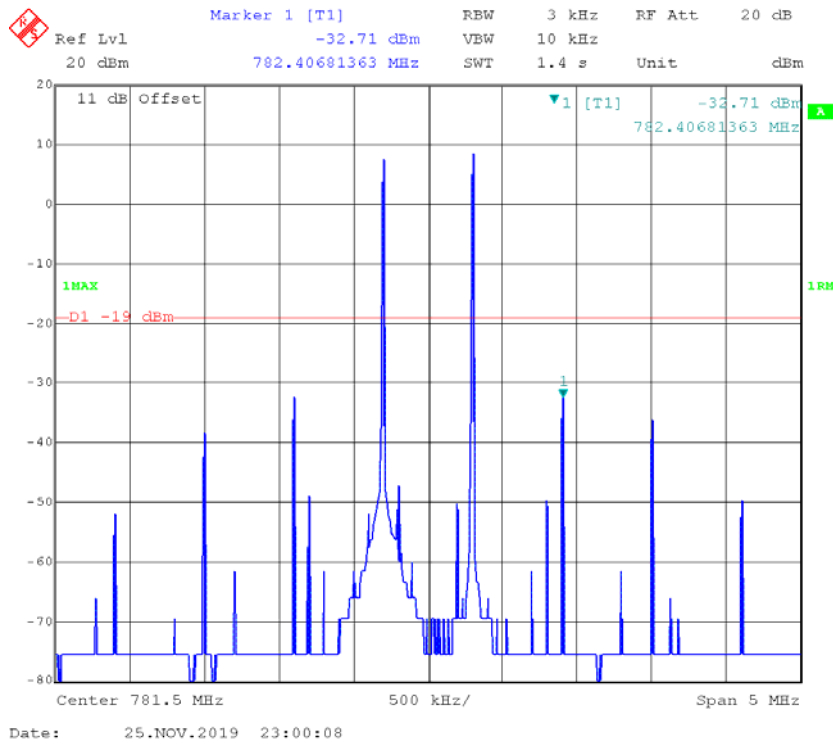

Cellular Band Pre-AGC

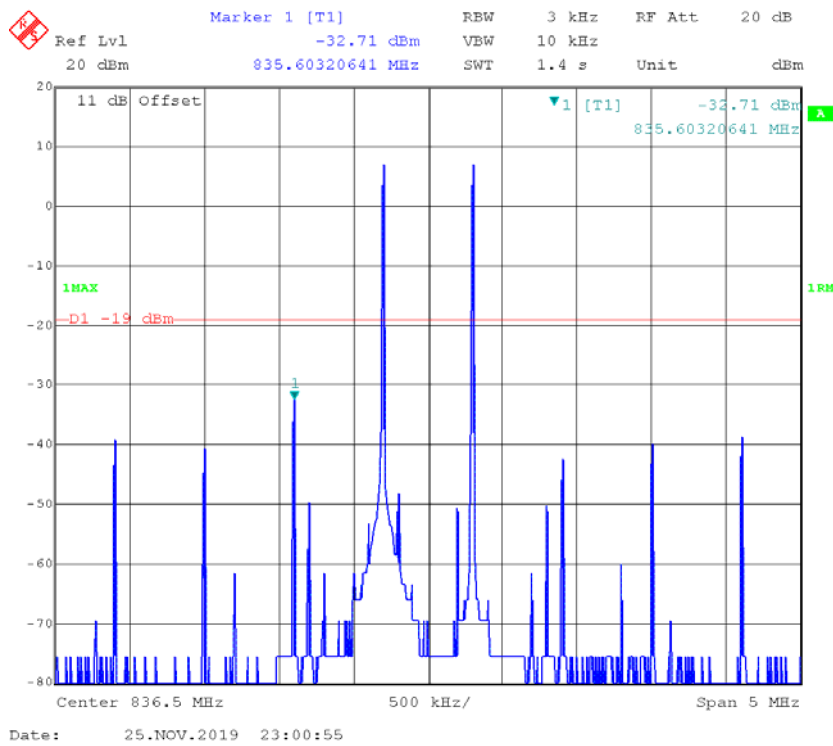

Cellular Band Band Above AGC

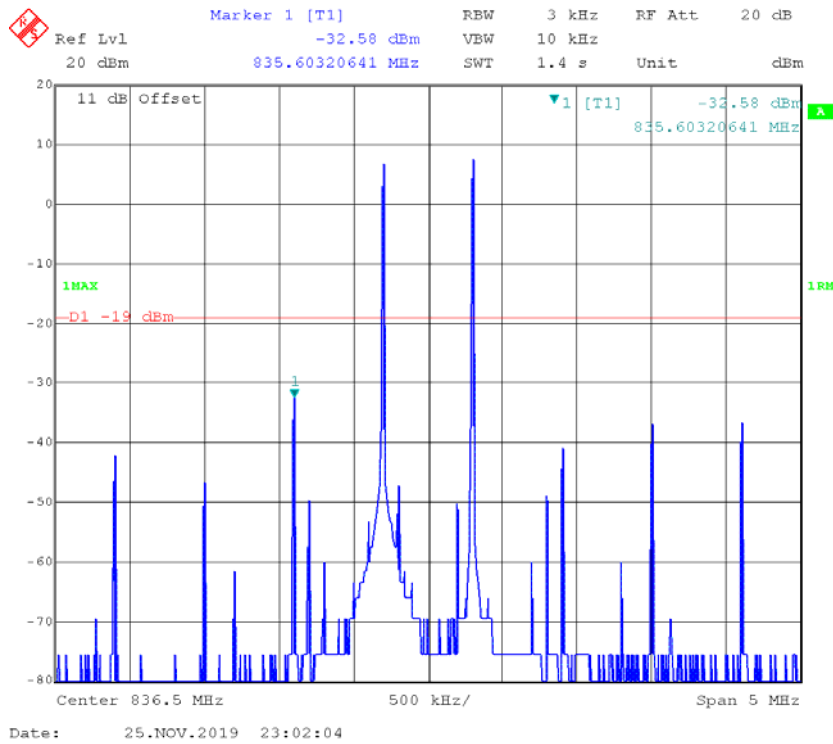

AWS Band Pre-AGC

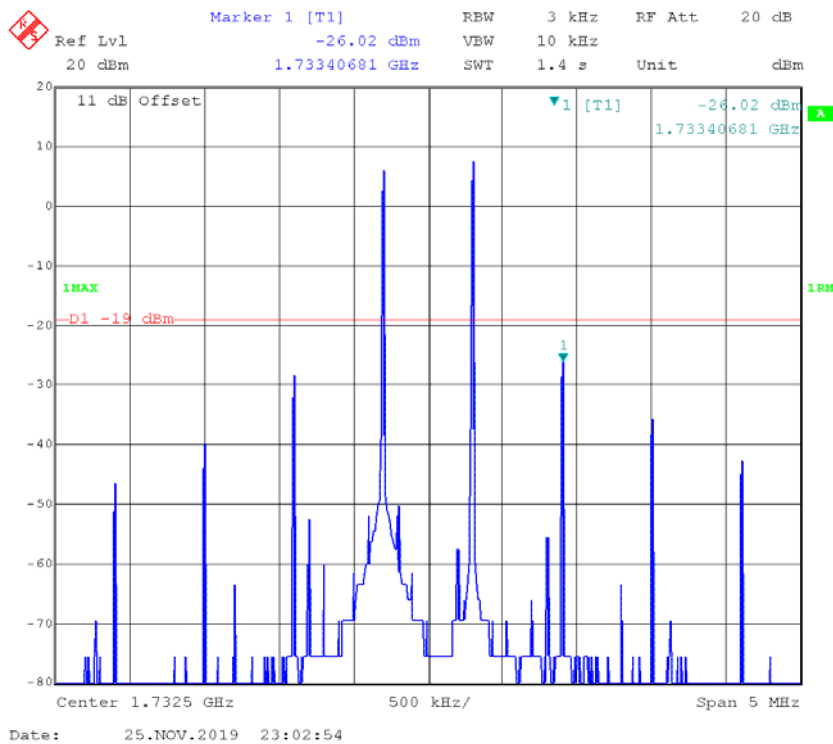

AWS Band Above AGC

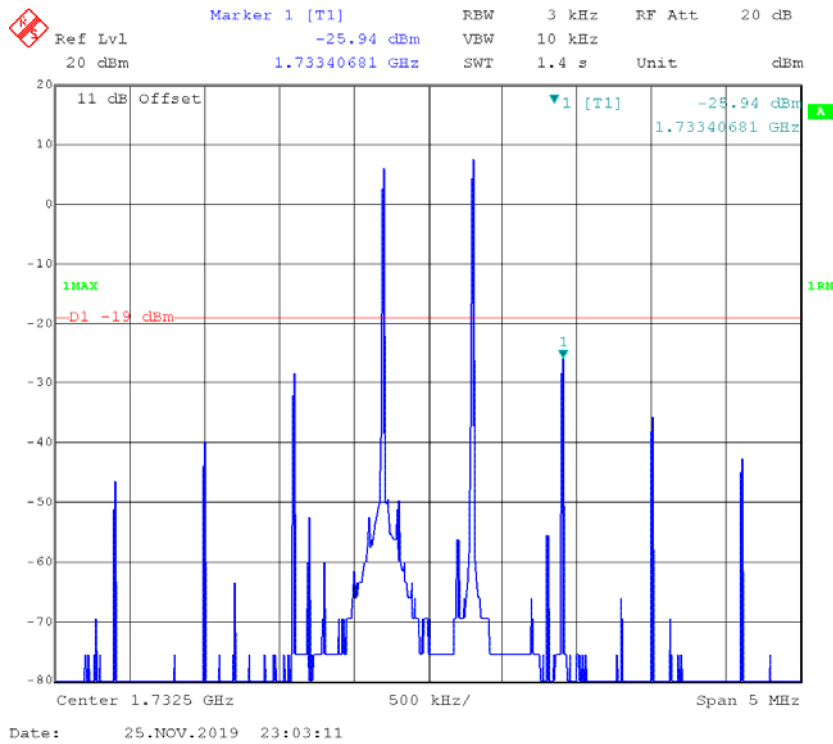

PCS Band Pre-AGC

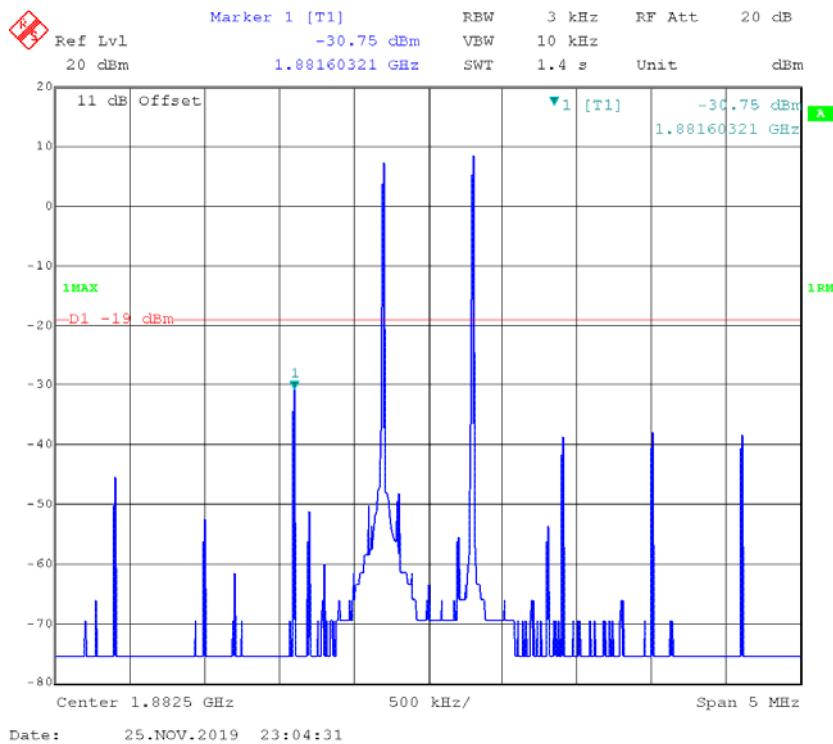

PCS Band Above AGC

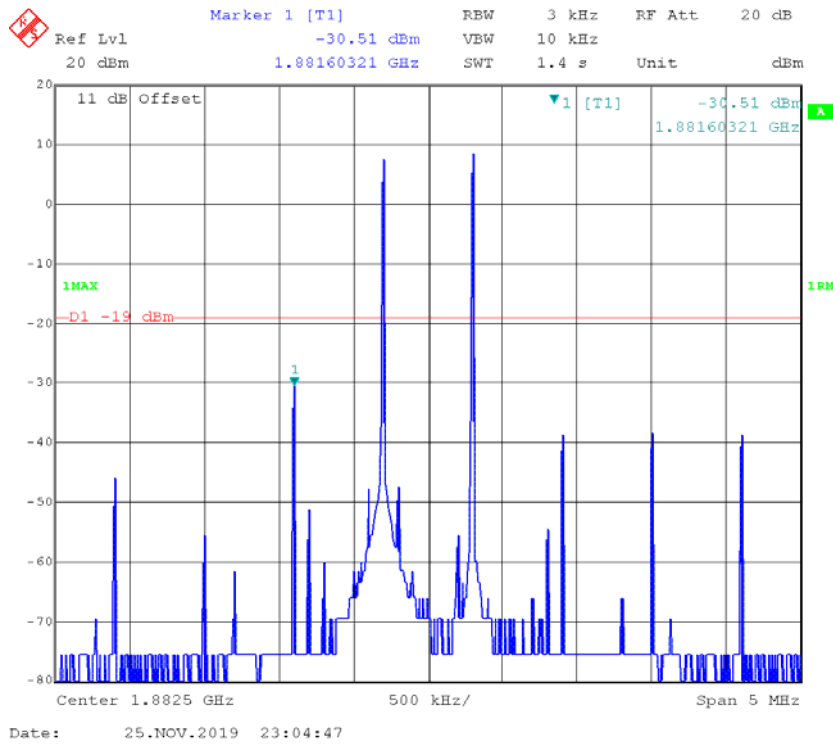

Downlink:

Lower 700MHz Band Pre-AGC

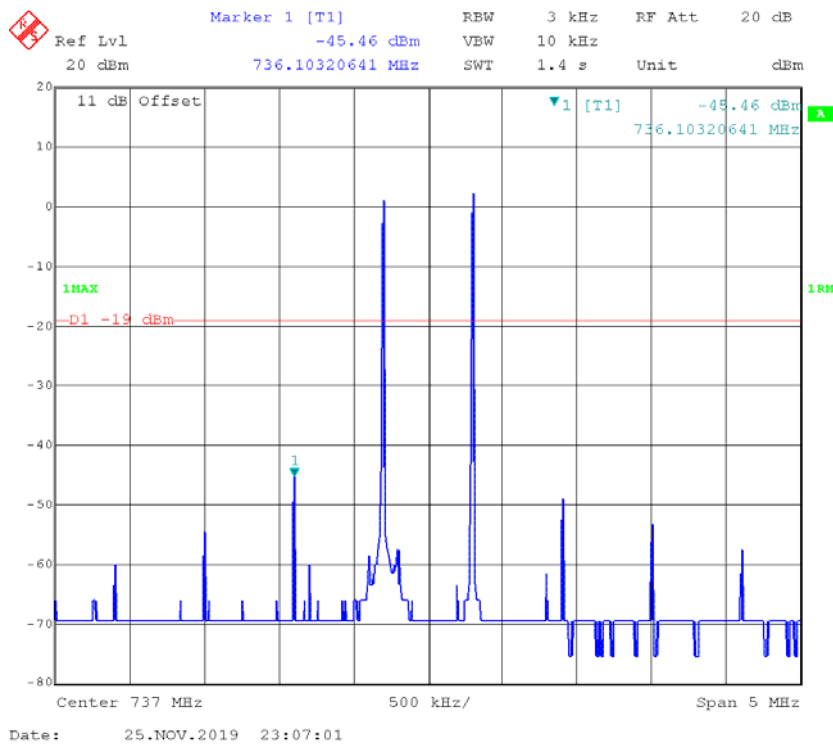

Lower 700MHz Band Above AGC

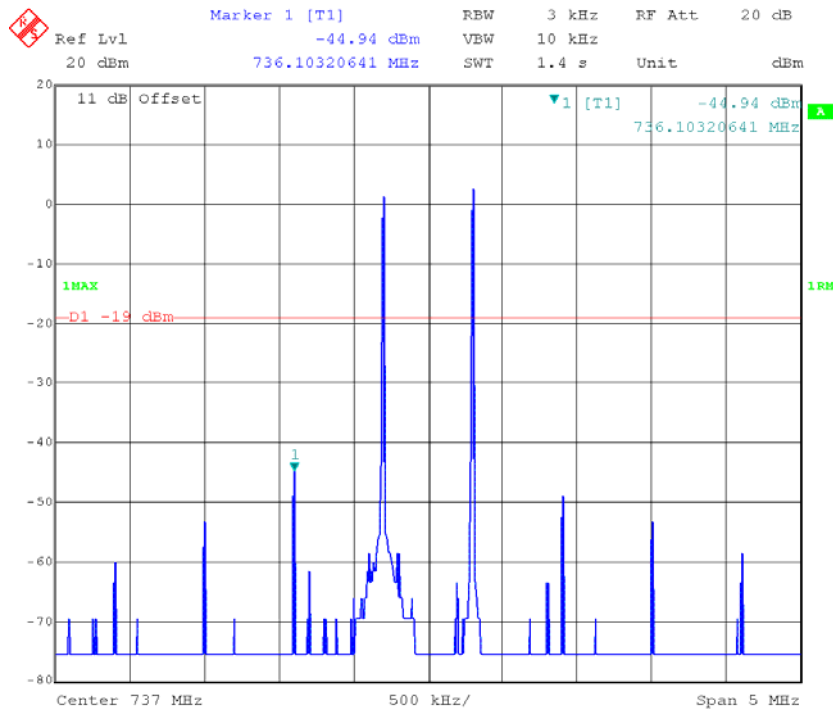

Upper 700MHz Band Pre-AGC

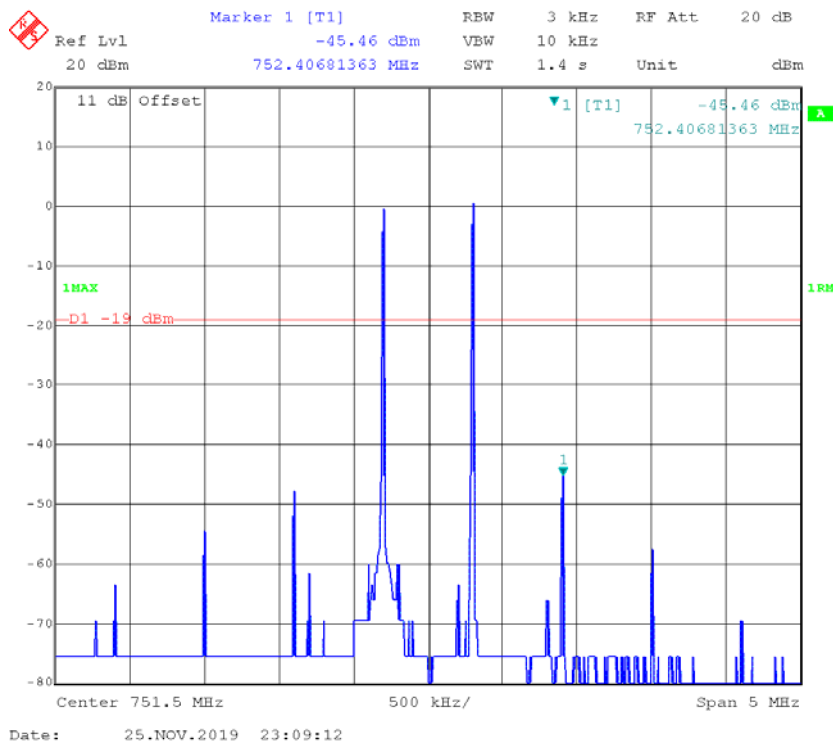

Upper 700MHz Band Above AGC

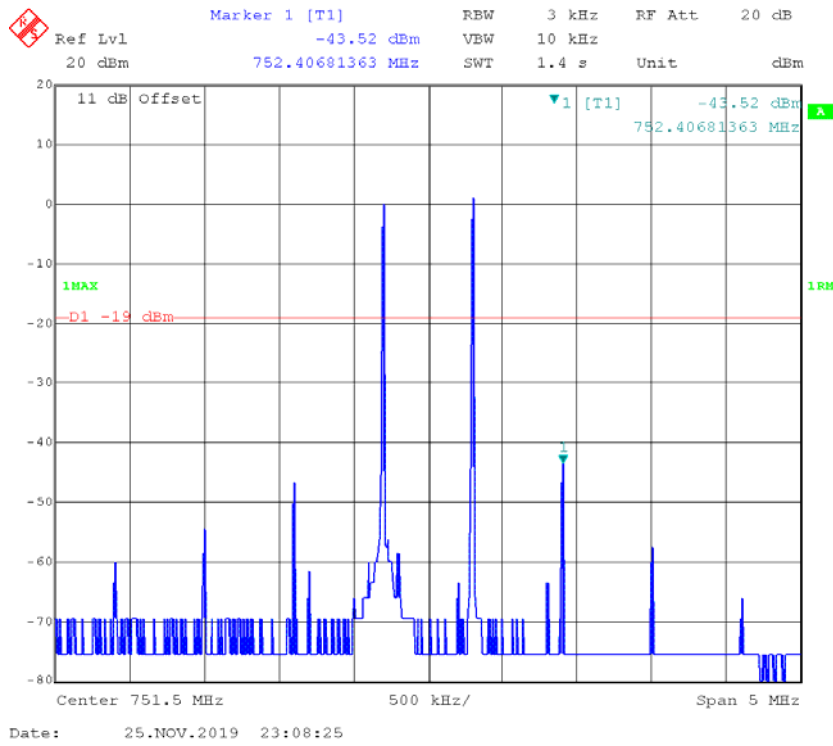

Cellular Band Pre-AGC

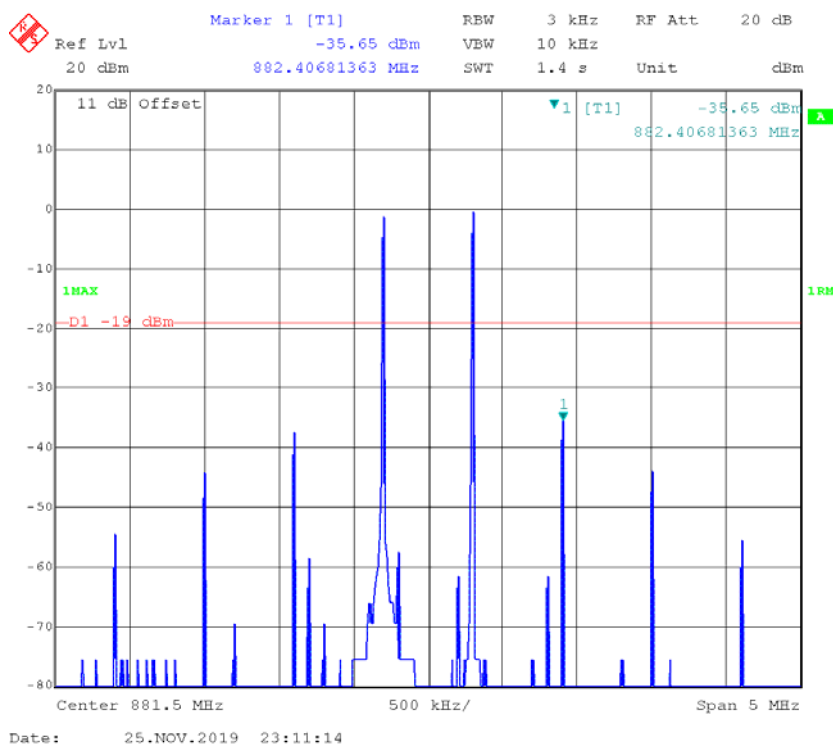

Cellular Band Band Above AGC

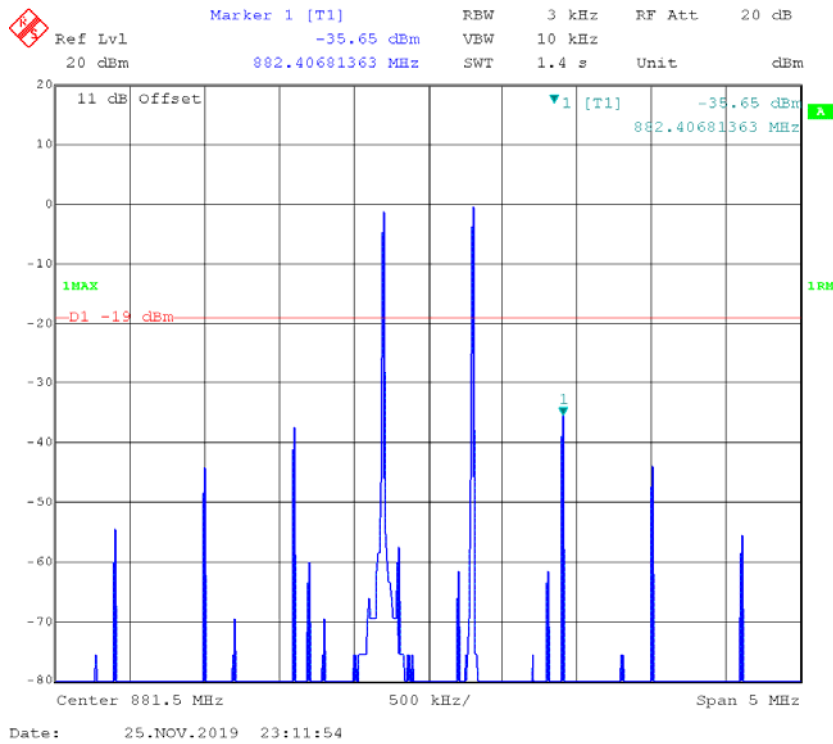

AWS Band Pre-AGC

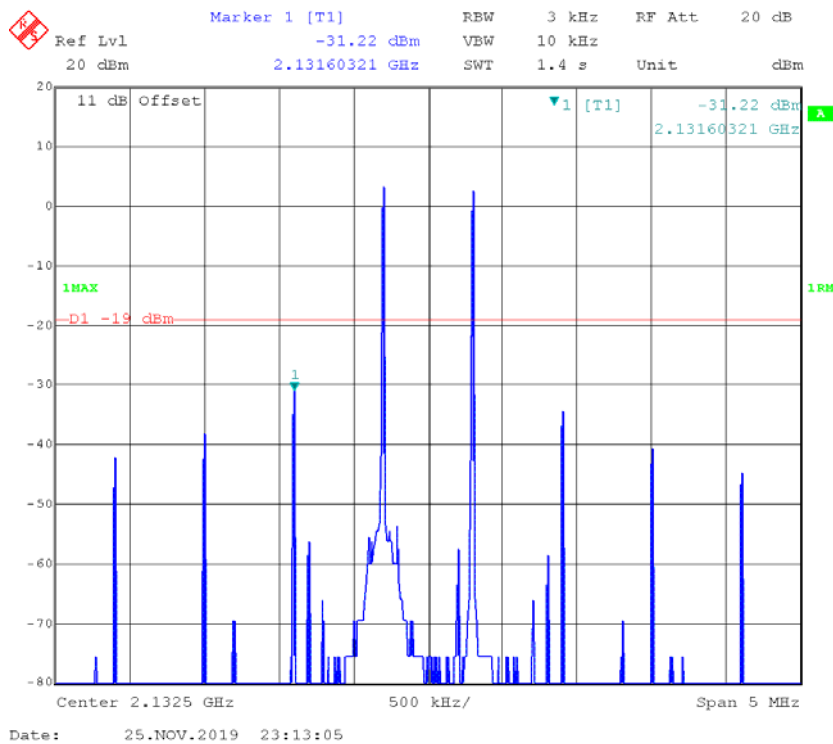

AWS Band Above AGC

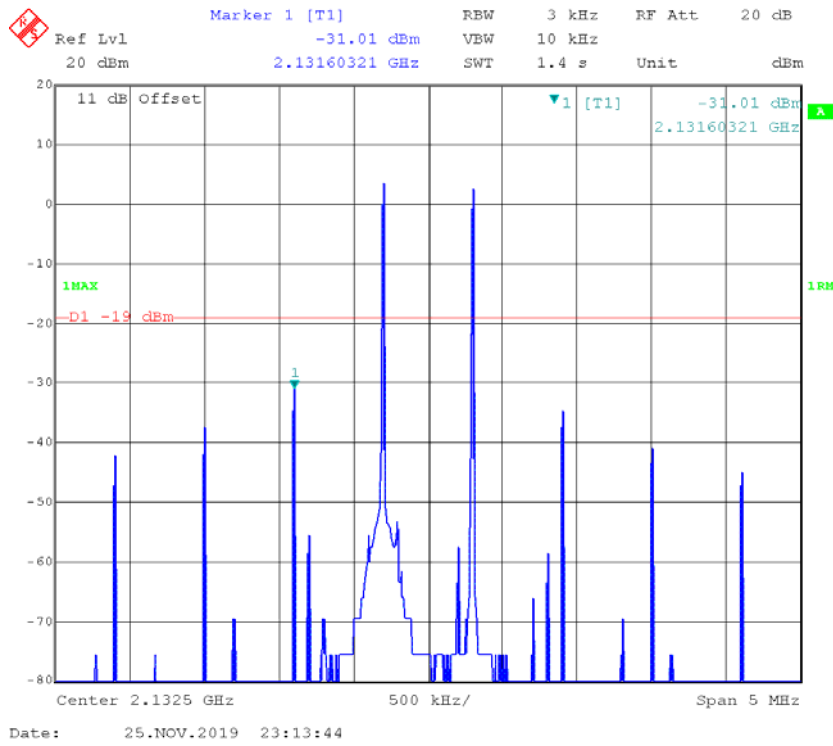

PCS Band Pre-AGC

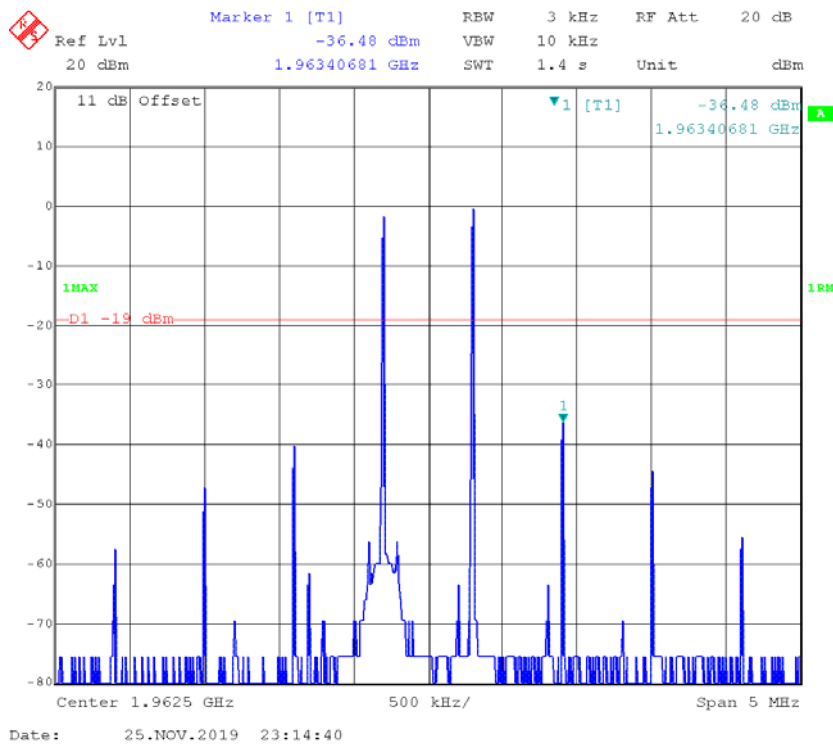

PCS Band Above AGC

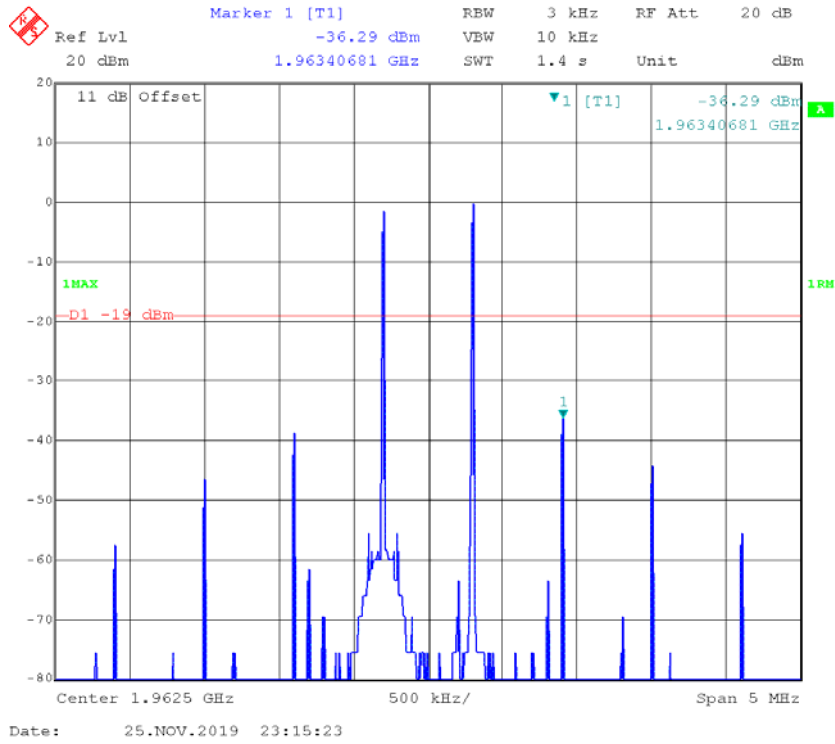

§ 20.21(e)(8)(i)(E)- OUT OF BAND EMISSIONS

Applicable Standards

According to § 20.21(e)(8)(i)(E) Out of Band Emission Limits.

Test Procedure

This measurement is intended to demonstrate compliance to the limit specified in § 20.21(e)(8)(i)(E). The mobile emission limit applicable to the supported band of operation can be determined from the applicable rule part as listed in Annex A for each authorized operating band.

- a) Connect the EUT to the test equipment as shown in **Figure 1**. Begin with the uplink output connected to the spectrum analyzer.
- b) Configure the signal generator for the appropriate operation for all uplink and downlink bands:
 - i) GSM: 0.2 MHz from upper and lower band edges.
 - ii) LTE (5 MHz): 2.5 MHz from upper and lower band edges.
 - iii) CDMA: 1.25 MHz from upper and lower band edges, except for cellular band as follows (only the upper and lower frequencies need to be tested):

824.88 MHz, 845.73 MHz, 836.52 MHz, 848.10 MHz, 869.88 MHz, 890.73 MHz, 881.52 MHz, 893.10 MHz.

Note 1: *Alternative test modulation types:*

- CDMA (alternative 1.25 MHz AWGN)
- LTE 5 MHz (alternative W-CDMA or 4.1 MHz AWGN)

Note 2: *For LTE, the signal generator should utilize the uplink and downlink signal types for these modulations in uplink and downlink tests, respectively. LTE shall use 5 MHz signal, 25 resource blocks transmitting.*

Note 3: *When using an AWGN test signal, the bandwidth shall be the measured 99% occupied bandwidth.*

- c) Set the signal generator amplitude to the maximum power level prior to AGC similar to the procedures in 7.2.2e) to 7.2.2f) of power measurement procedure for appropriate modulations.
- d) Set RBW = measurement bandwidth specified in the applicable rule section for the supported frequency band (*see Annex A for cross-reference to applicable rule section*).
- e) Set VBW = $3 \times$ RBW.
- f) Select the RMS (power averaging) detector.
- g) Sweep time = auto-couple.
- h) Set the analyzer start frequency to the upper band/block edge frequency and the stop frequency to the upper band/block edge frequency plus 300 kHz (when operational frequency is < 1 GHz) or 3 MHz (when operational frequency is \geq 1 GHz).
- i) Trace average at least 100 traces in power averaging (i.e., RMS) mode.
- j) Use peak marker function to find the maximum power level.
- k) Capture the spectrum analyzer trace of the power level for inclusion in the test report.
- l) Increase the signal generator amplitude in 2 dB steps until the maximum input level indicated in 5.5 is reached. Affirm that the EUT maintains compliance with the OOB limits.
- m) Reset the analyzer start frequency to the lower band/block edge frequency minus 300 kHz (when operational frequency is < 1 GHz) or 3 MHz (when operational frequency is \geq 1 GHz), and the stop frequency to the lower band/block edge frequency and repeat 7.5j) to 7.5l).
- n) Repeat 7.5b) through 7.5m) for each uplink and downlink operational band.

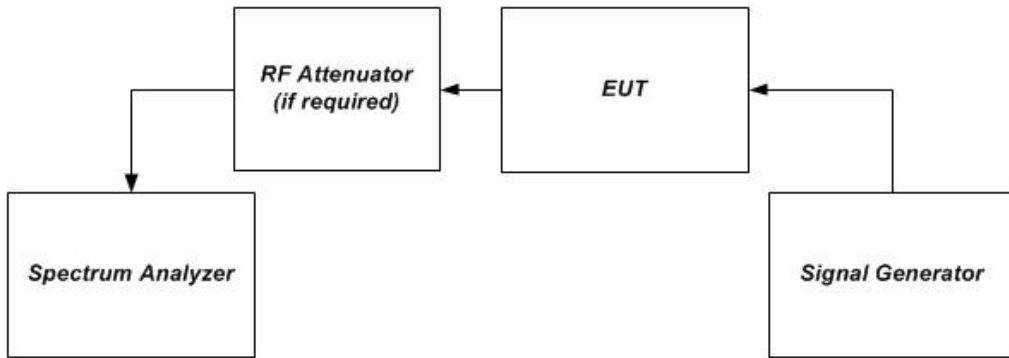

Figure 1 – Band verification test instrumentation setup

Test Data

Environmental Conditions

Temperature:	25.9 °C
Relative Humidity:	42 %
ATM Pressure:	101.2 kPa

The testing was performed by Blake Yang on 2019-11-27.

Test Result: Compliance. Please refer to following plots.

**Uplink:
Lower 700MHz Band:**

CDMA Left Side Pre-AGC

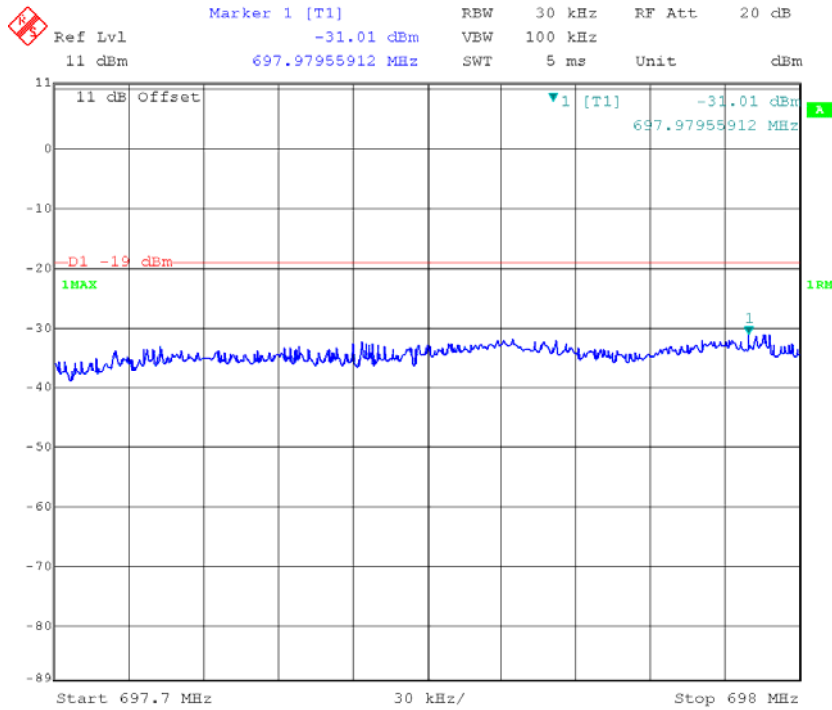

Date: 27.NOV.2019 17:53:29

CDMA Left Side Above AGC

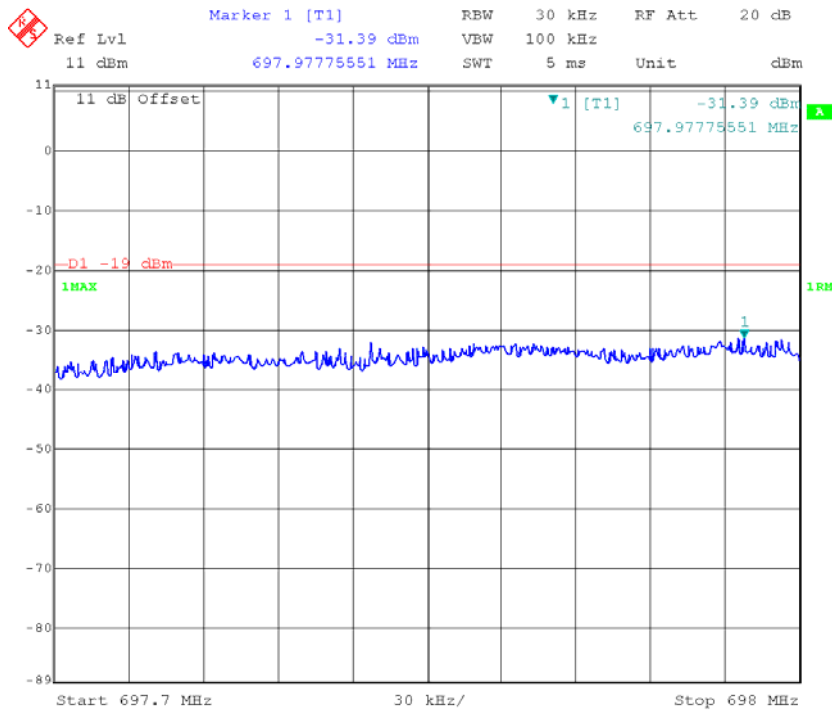

Date: 27.NOV.2019 17:54:08

GSM Left Side Pre-AGC

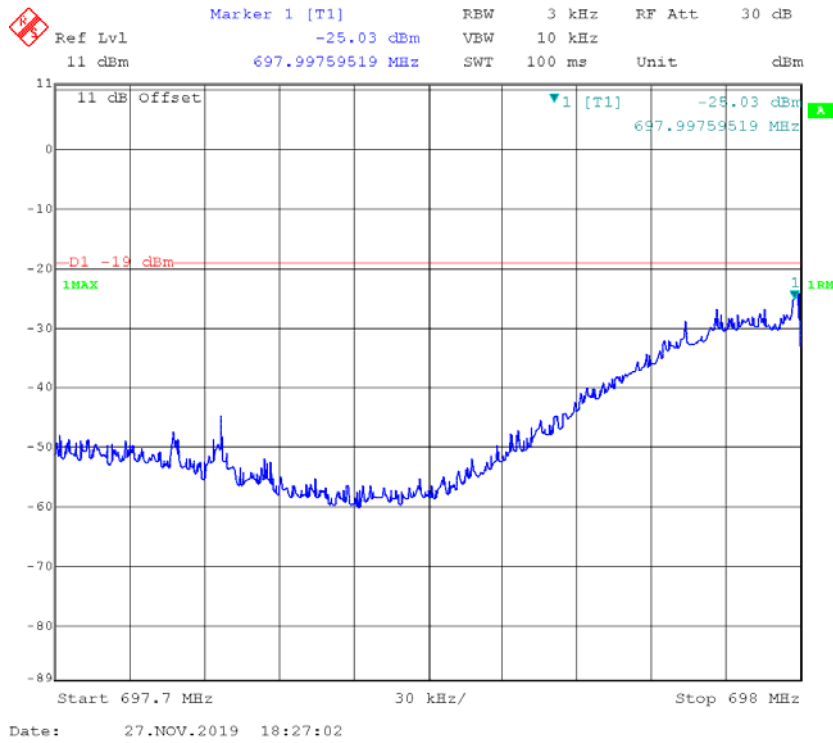

GSM Left Side Above AGC

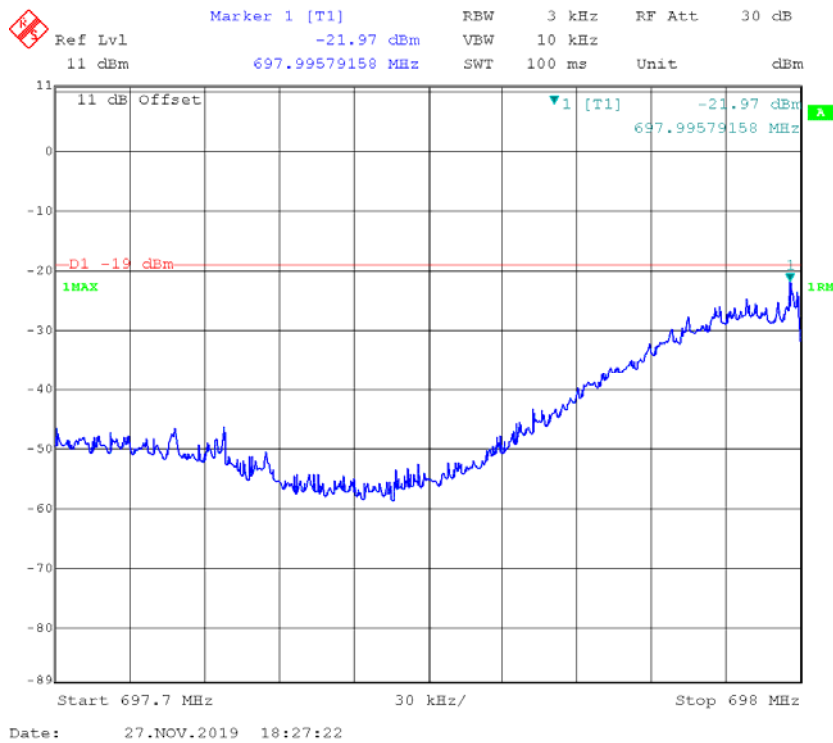

GSM Right Side Pre-AGC

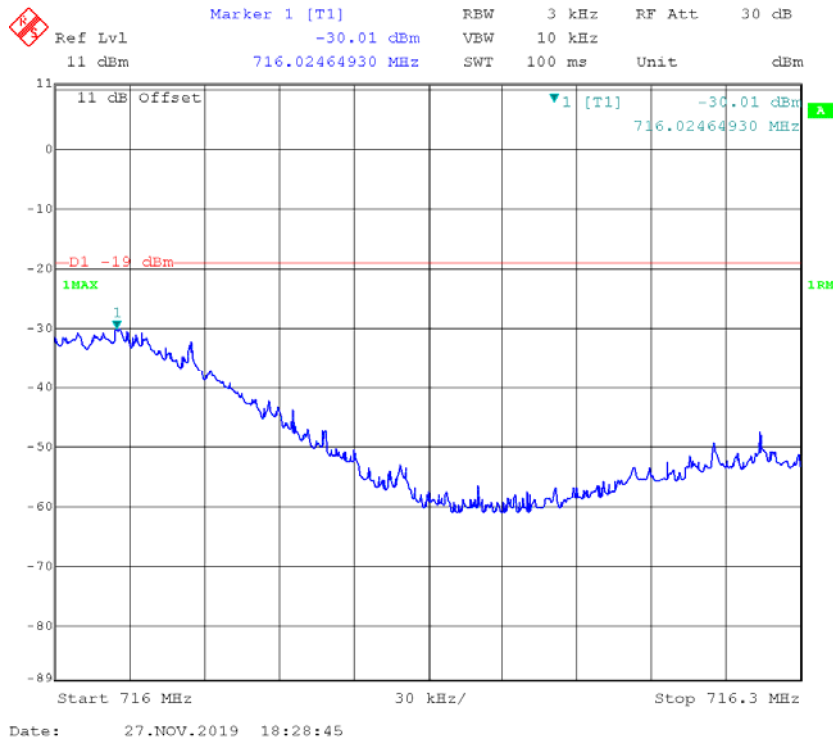

GSM Right Side Above AGC

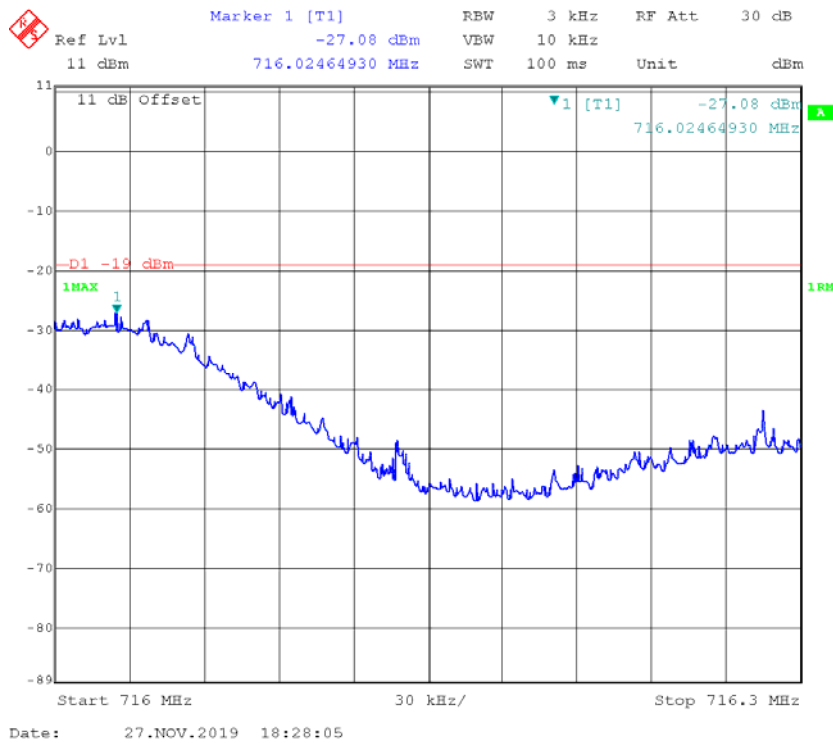

LTE Left Side Pre-AGC

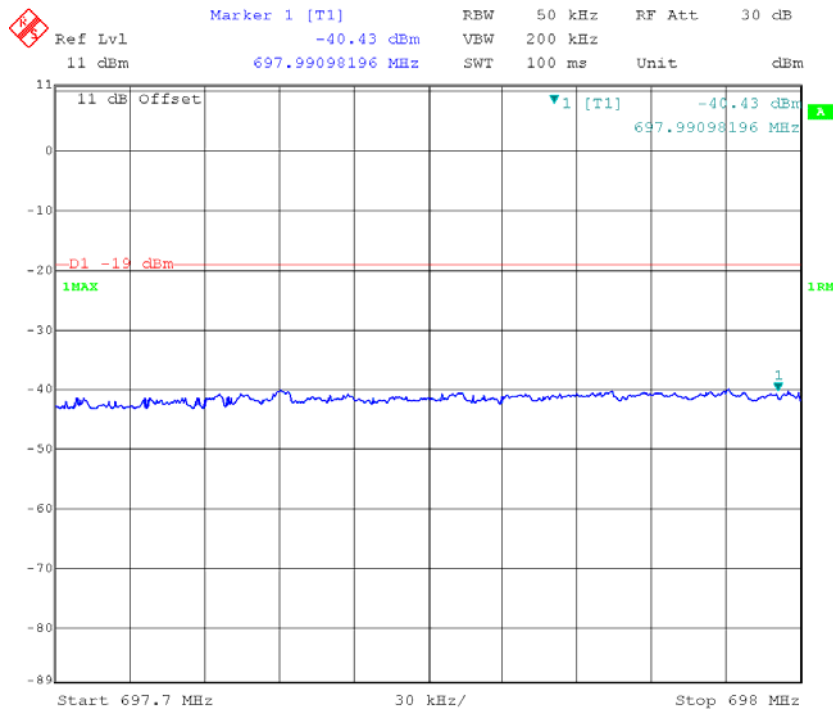

Date: 27.NOV.2019 18:34:05

LTE Left Side Above AGC

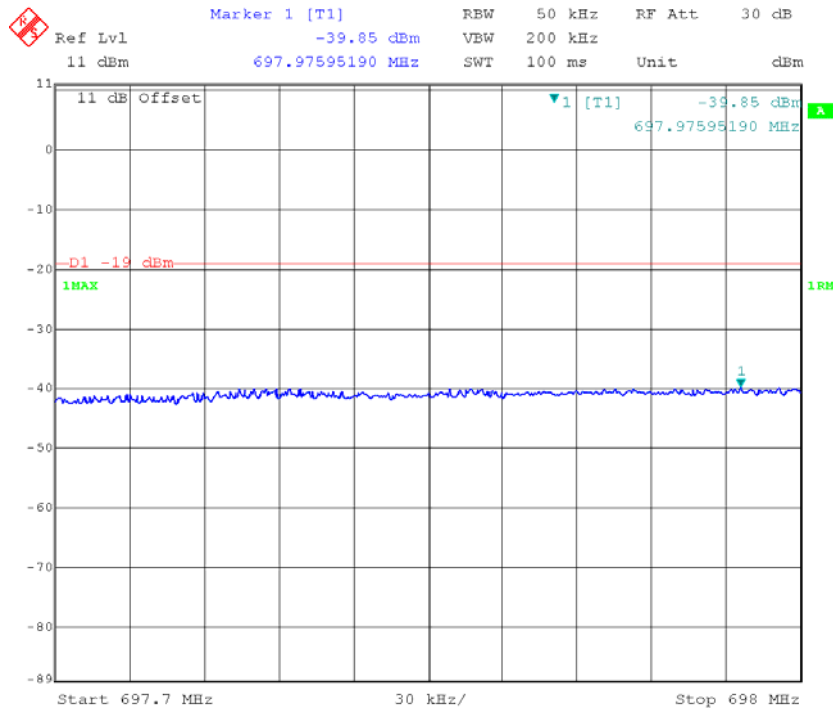

Date: 27.NOV.2019 18:34:22

LTE Right Side Pre-AGC

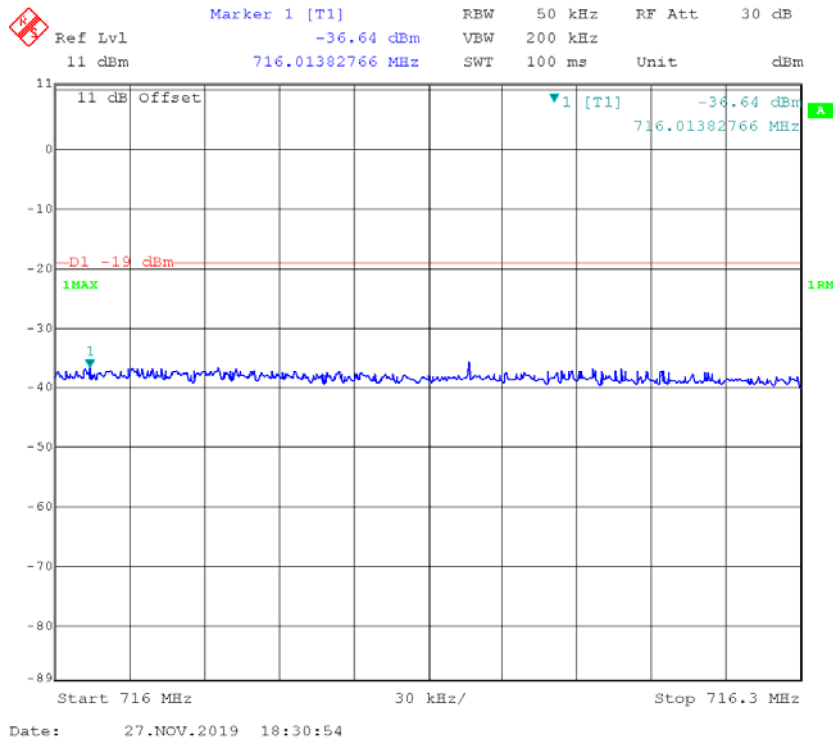

LTE Right Side Above AGC

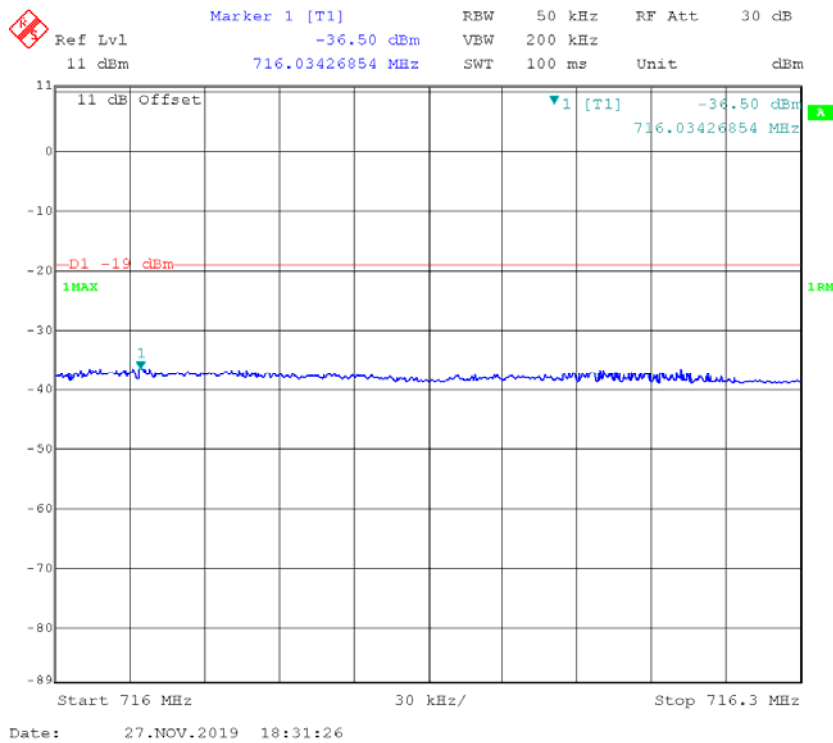

Upper 700MHz Band:

CDMA Left Side Pre-AGC

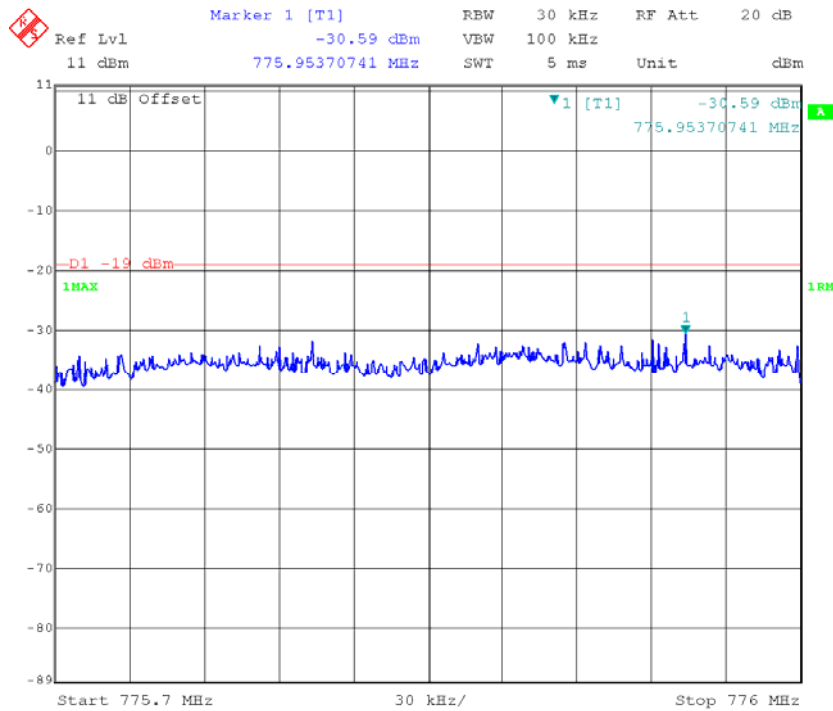

Date: 27.NOV.2019 17:55:47

CDMA Left Side Above AGC

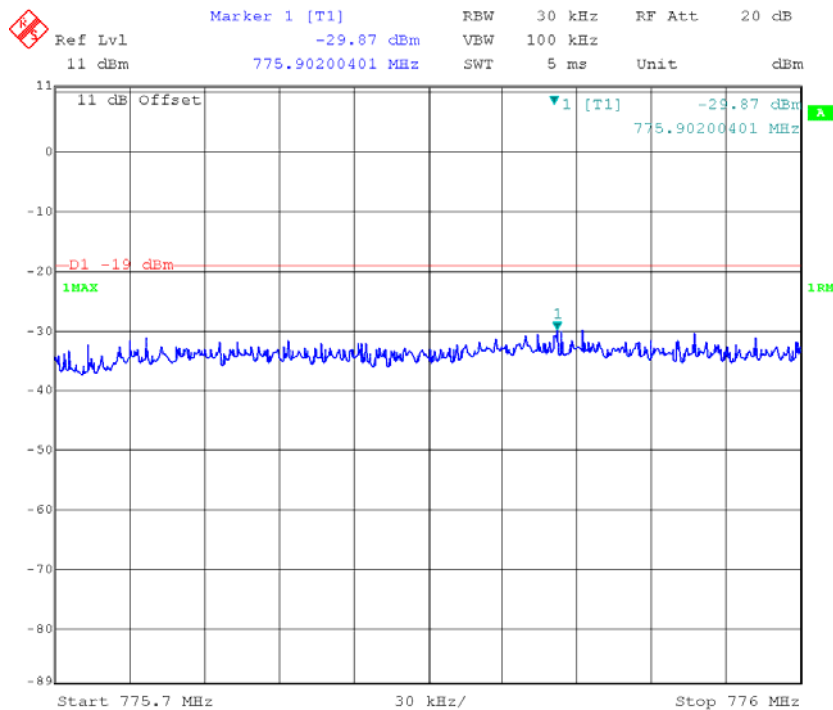

Date: 27.NOV.2019 17:55:18

CDMA Right Side Pre-AGC

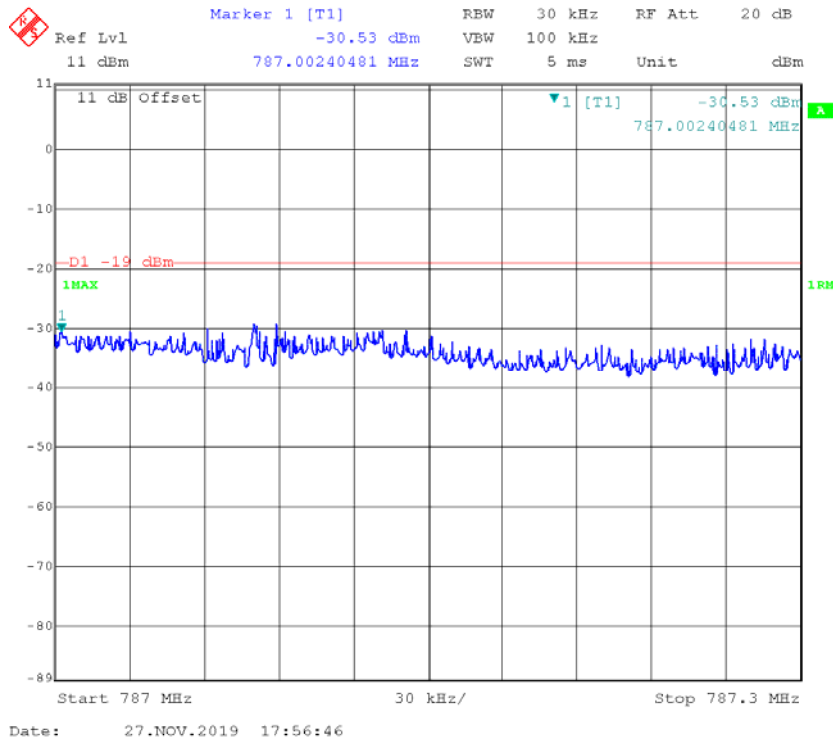

CDMA Right Side Above AGC

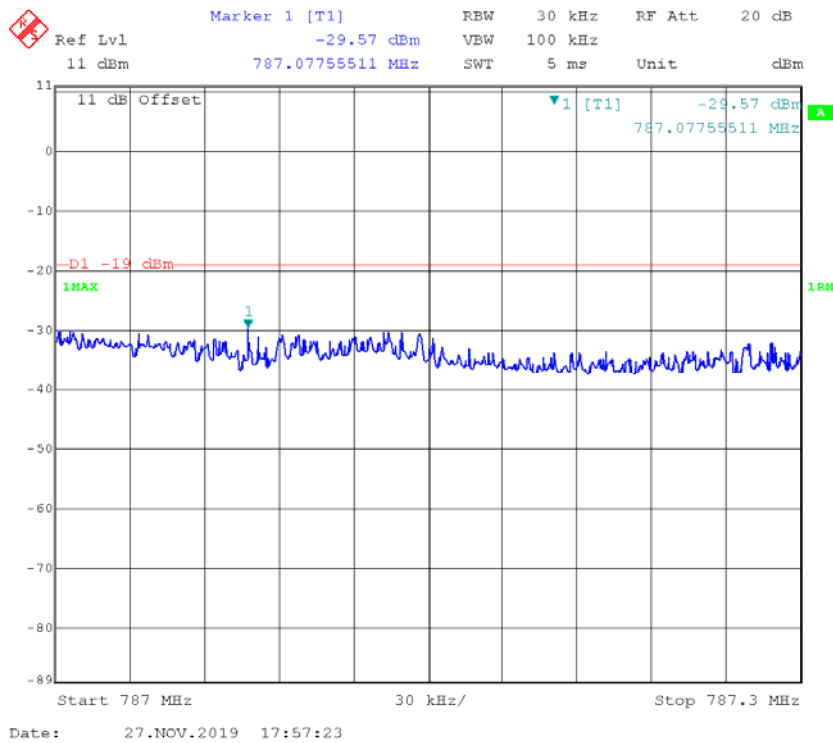

GSM Left Side Pre-AGC

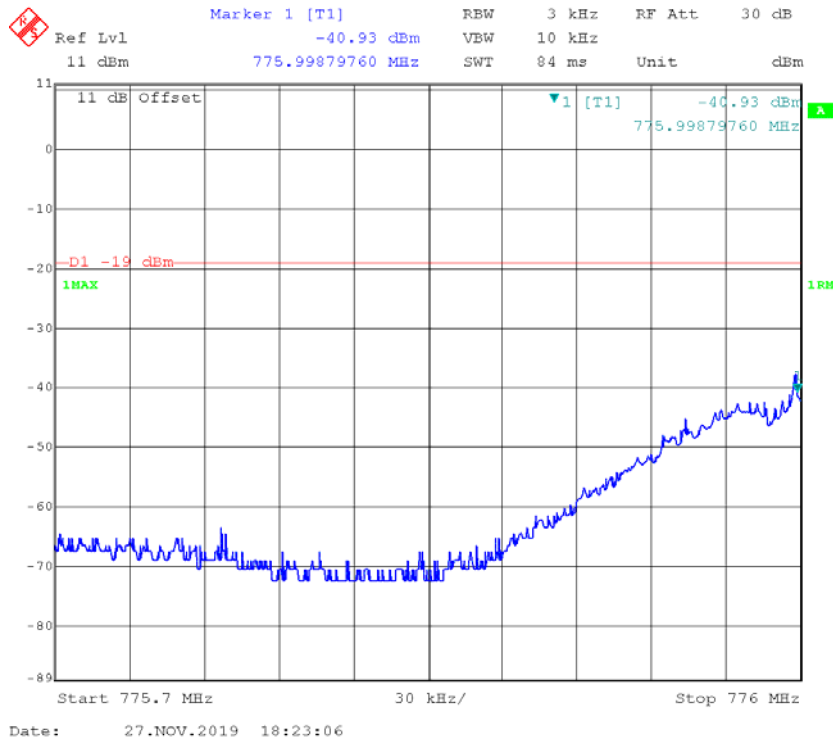

GSM Left Side Above AGC

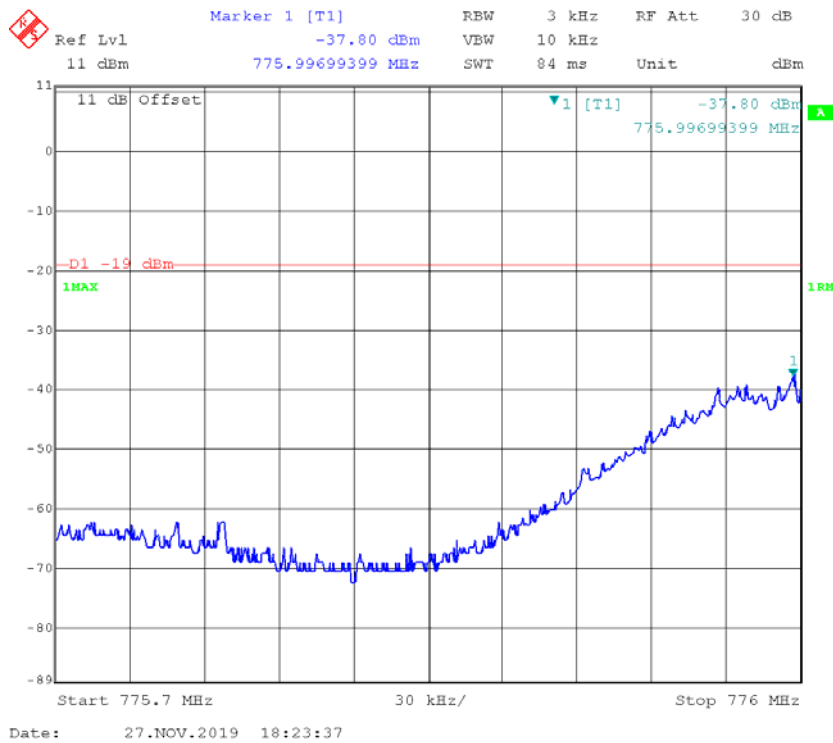

GSM Right Side Pre-AGC

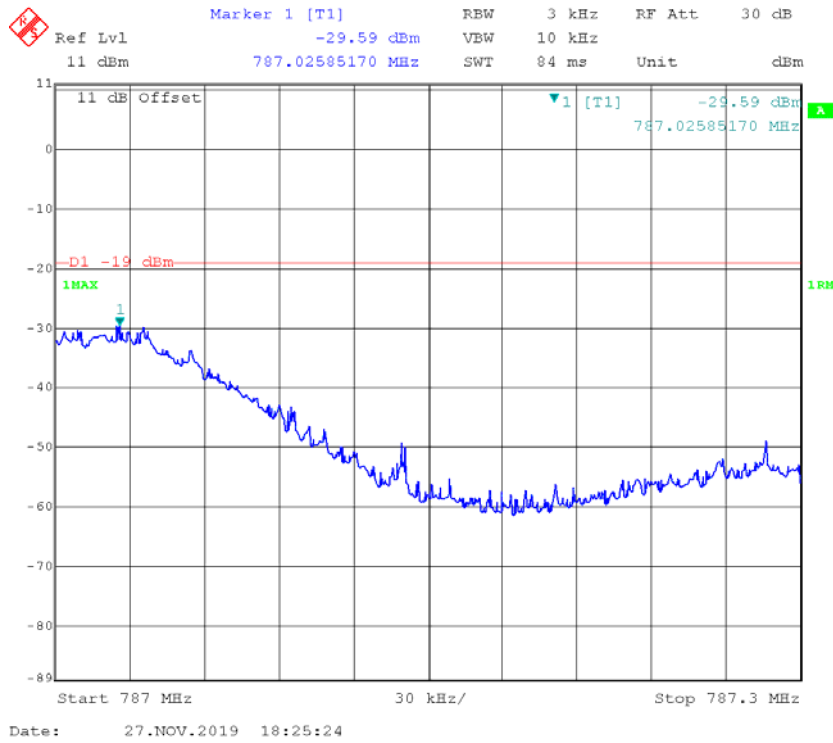

GSM Right Side Above AGC

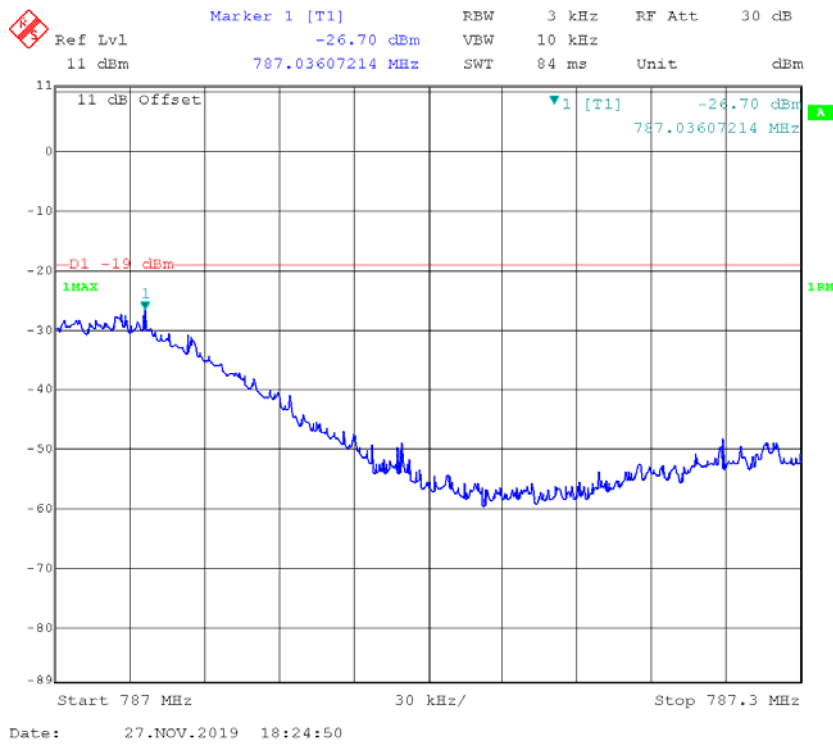

LTE Right Side Pre-AGC

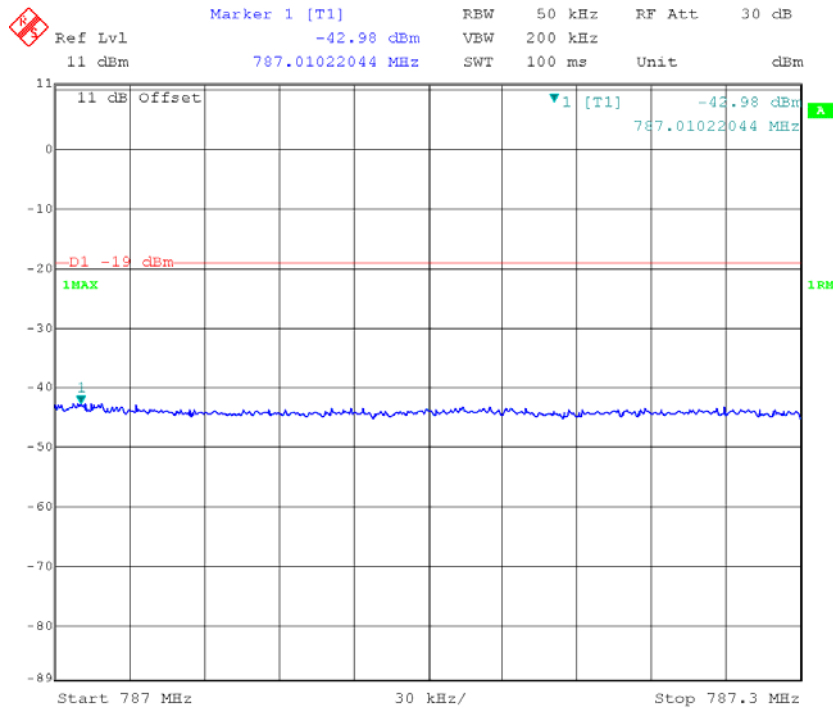

LTE Right Side Above AGC

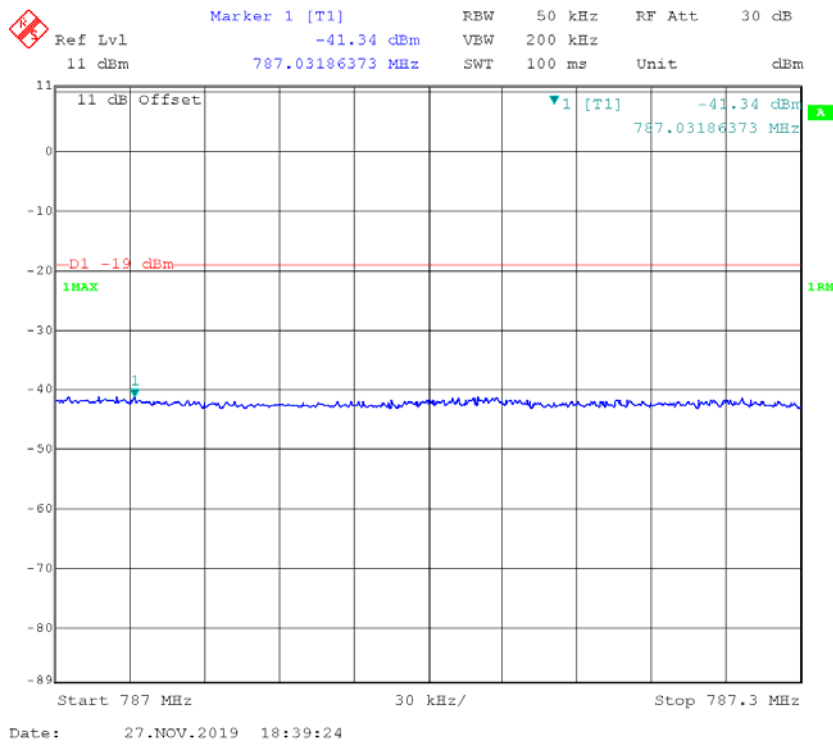

CDMA Right Side Pre-AGC

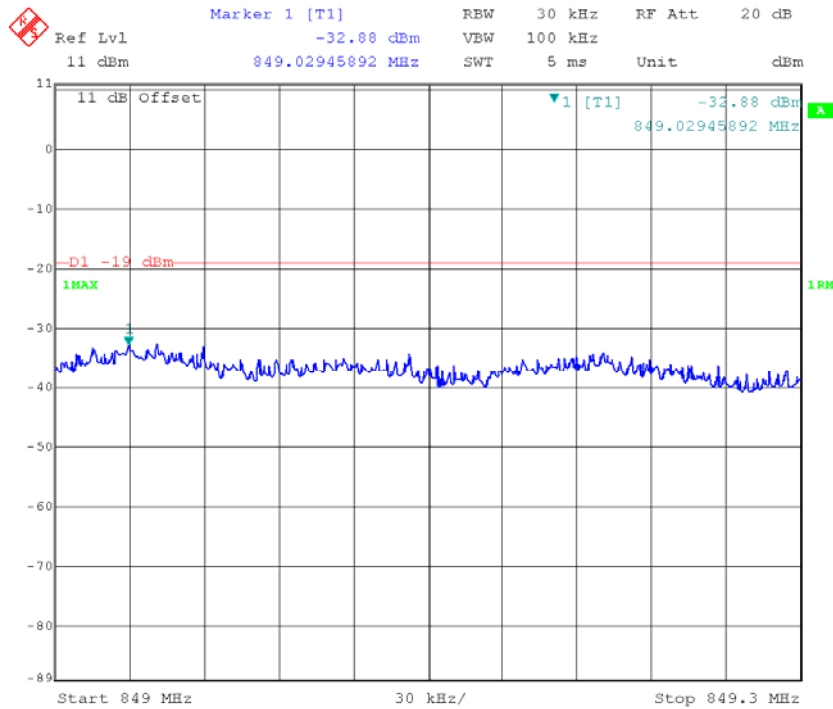

CDMA Right Side Above AGC

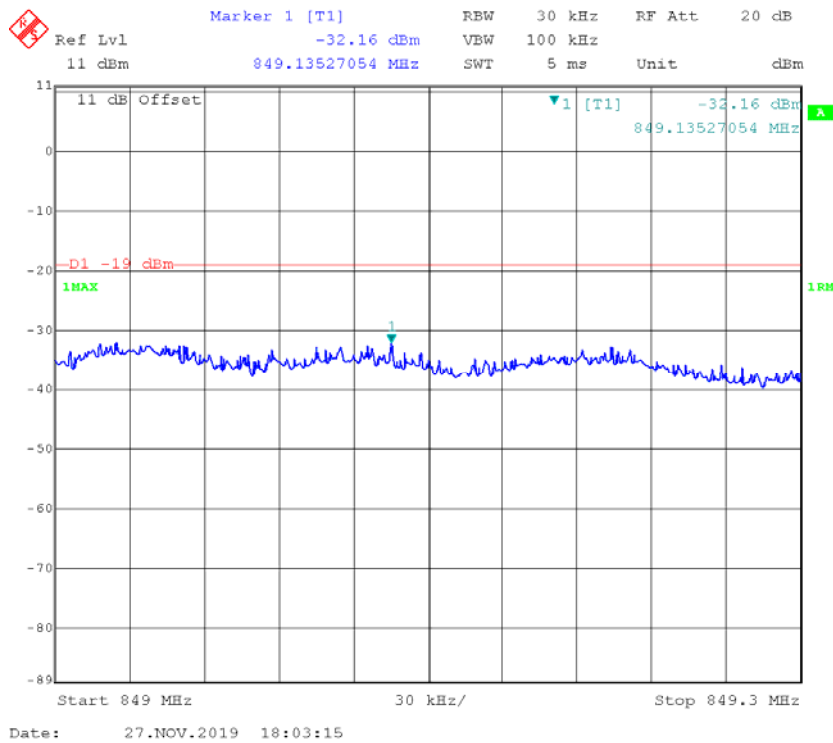

GSM Left Side Pre-AGC

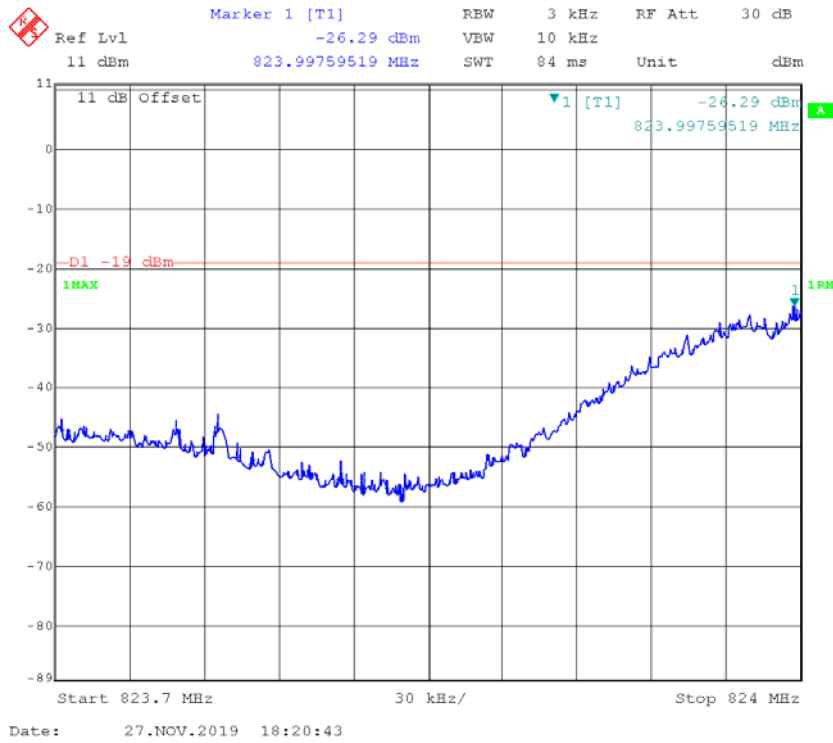

GSM Left Side Above AGC

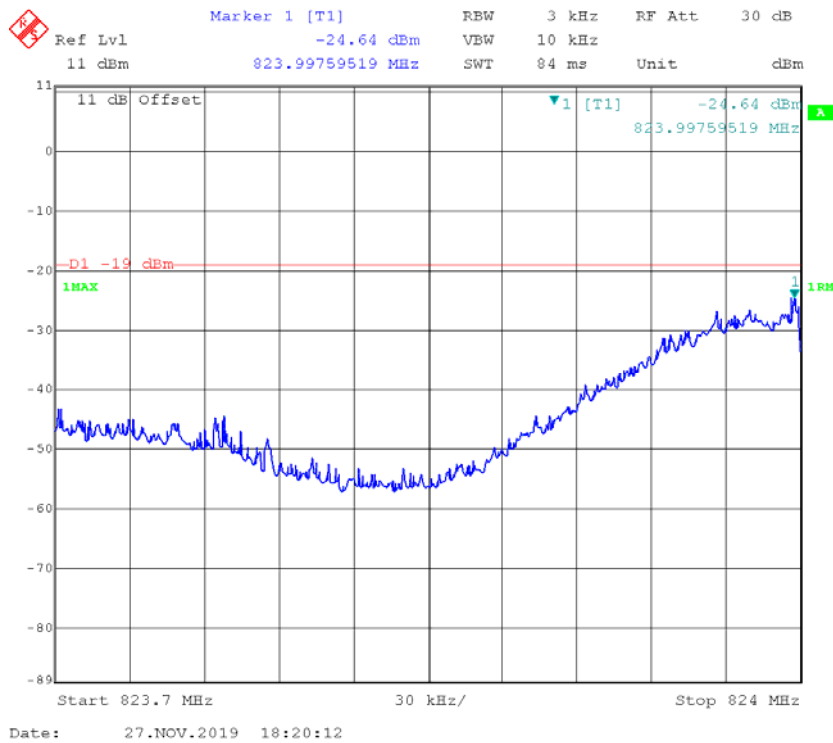

GSM Right Side Pre-AGC

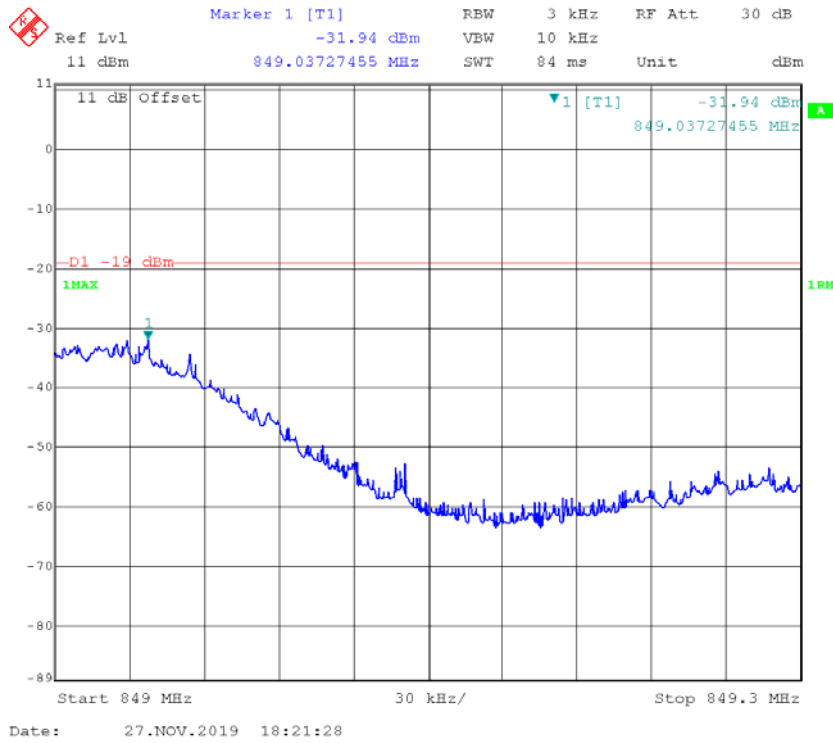

GSM Right Side Above AGC

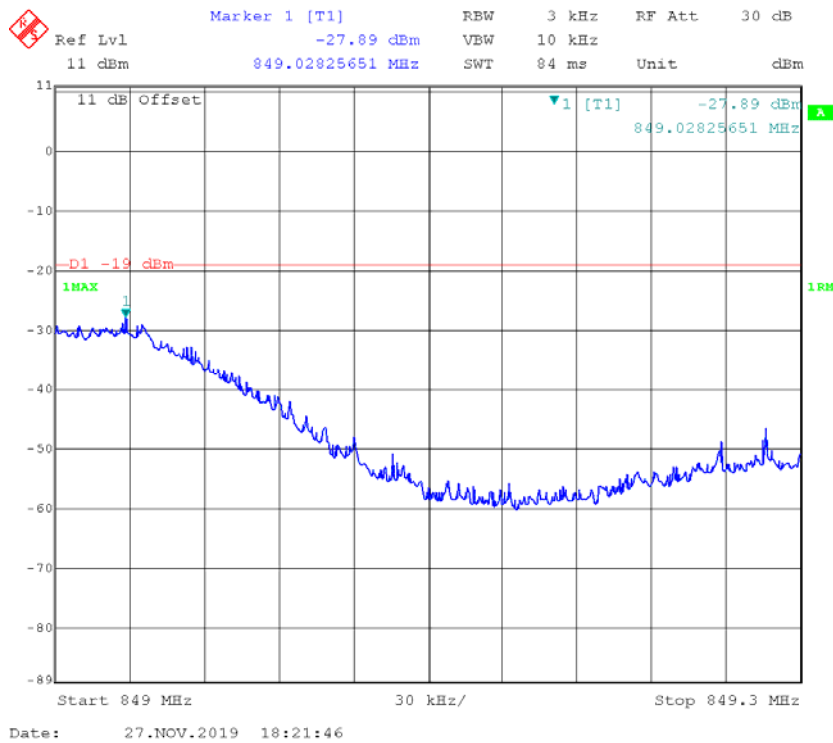

LTE Left Side Pre-AGC

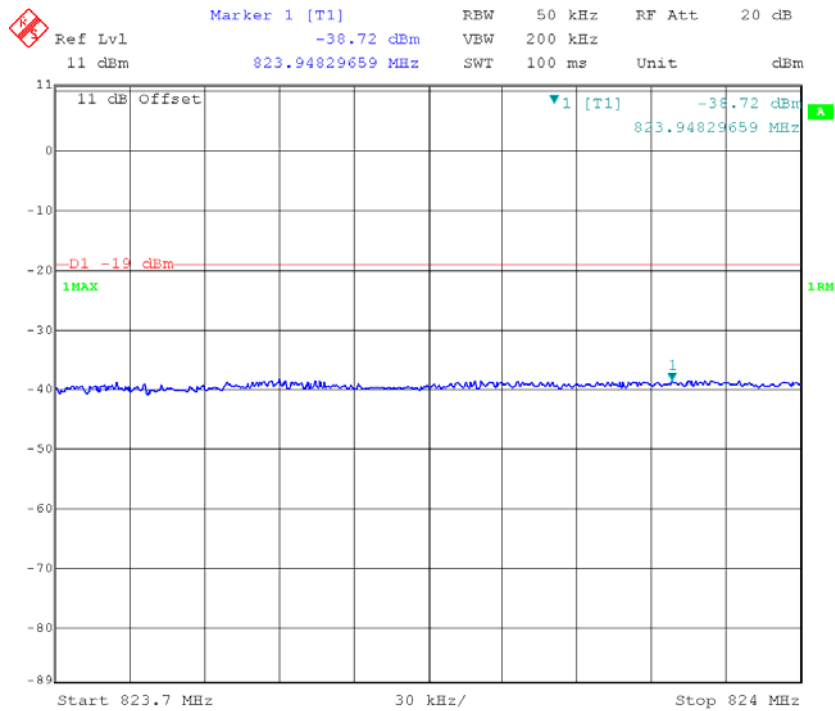

Date: 27.NOV.2019 18:40:50

LTE Left Side Above AGC

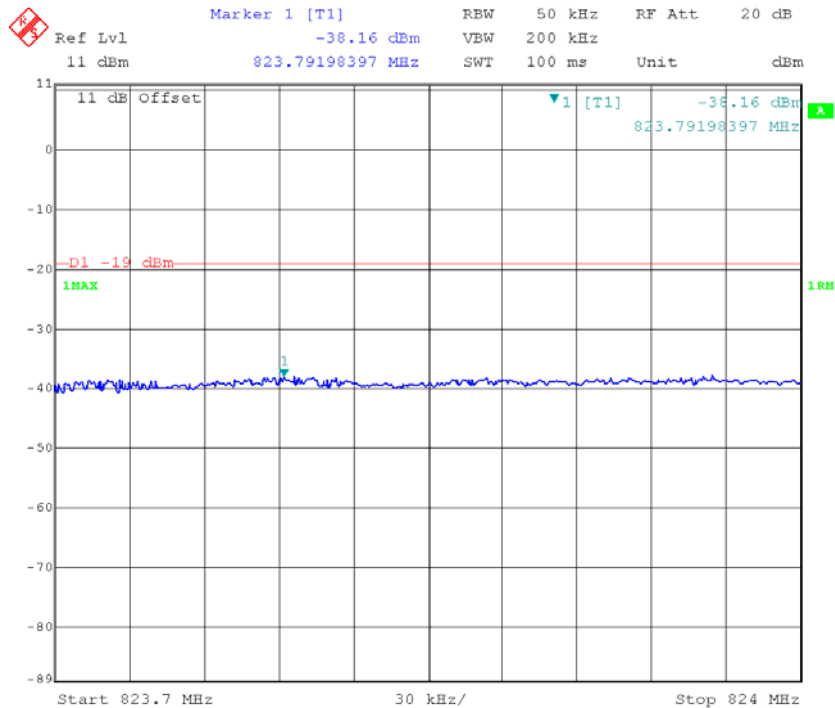

Date: 27.NOV.2019 18:41:05

LTE Right Side Pre-AGC

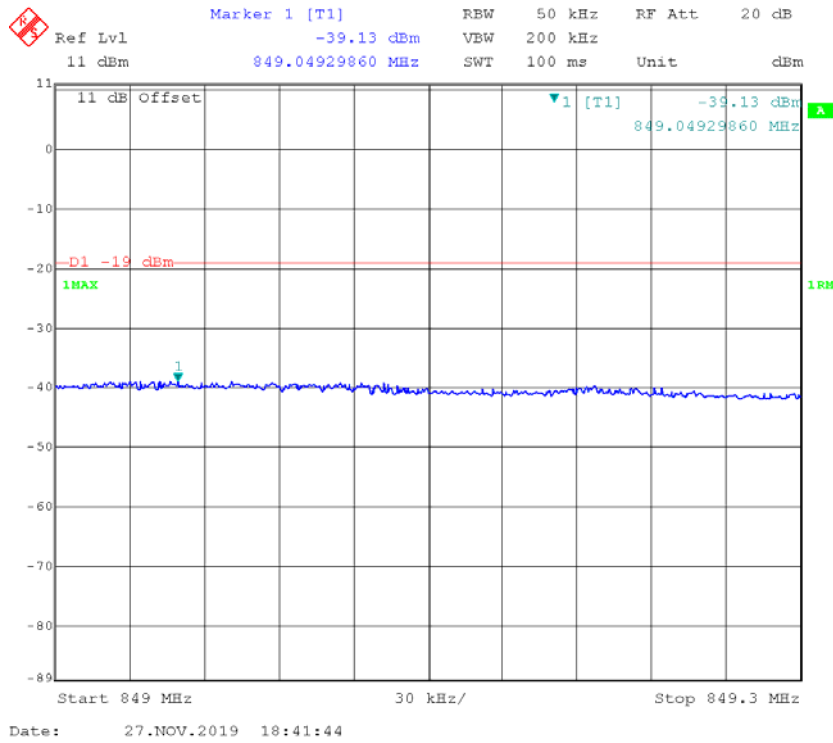

LTE Right Side Above AGC

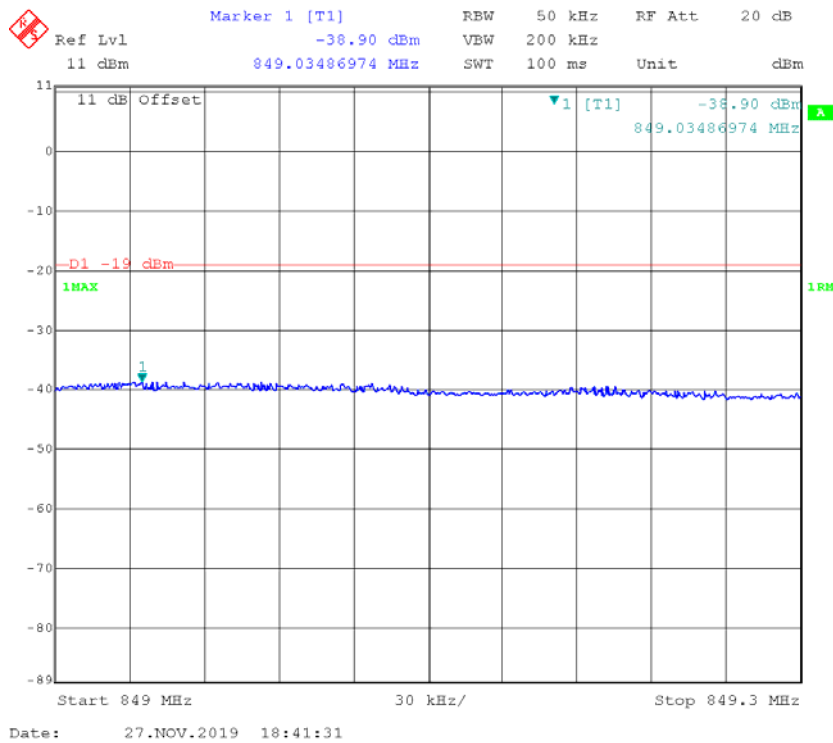

AWS Band:

CDMA Left Side Pre-AGC

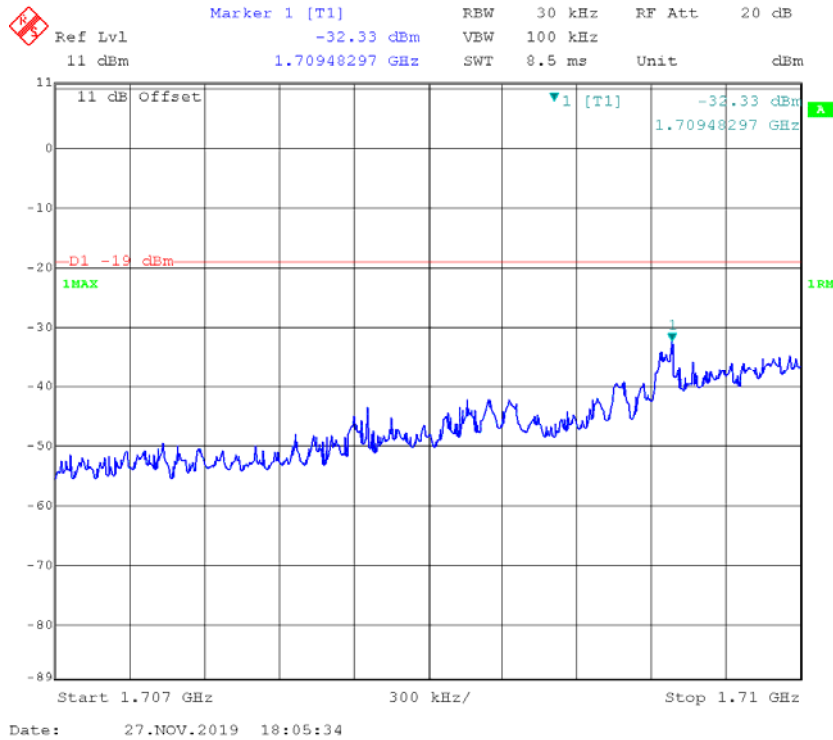

CDMA Left Side Above AGC

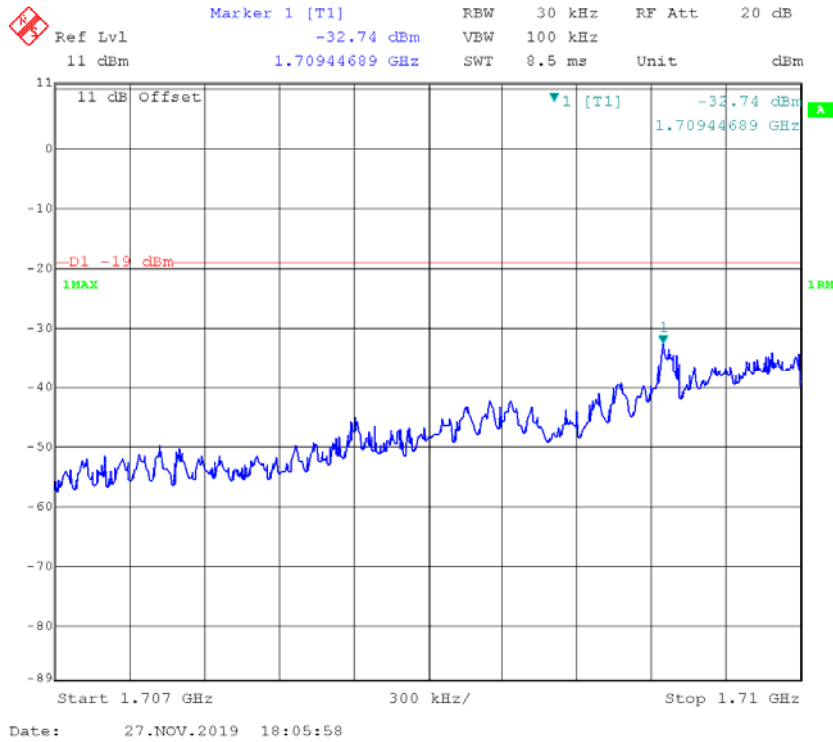

CDMA Right Side Pre-AGC

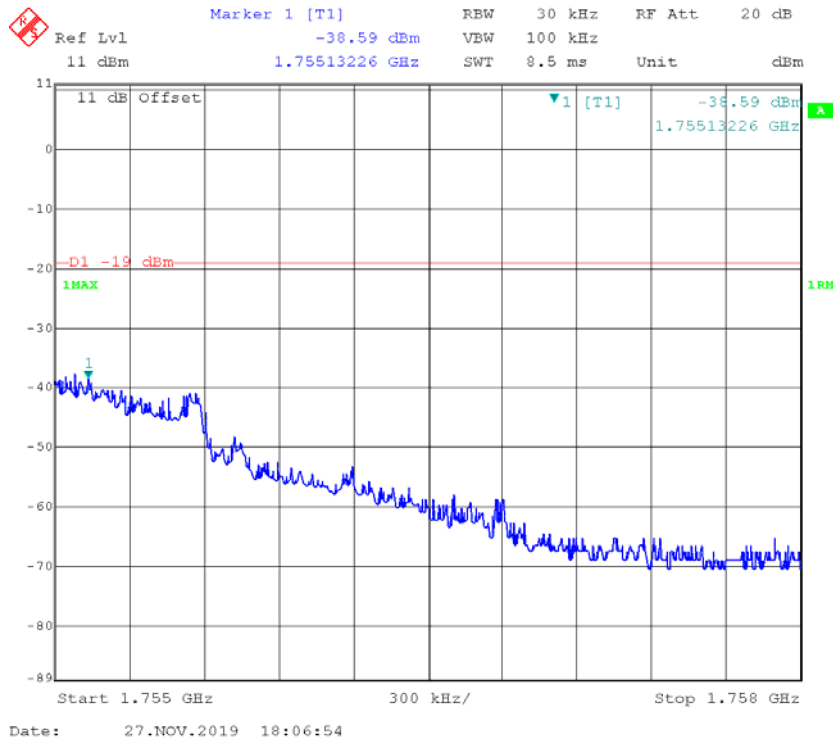

CDMA Right Side Above AGC

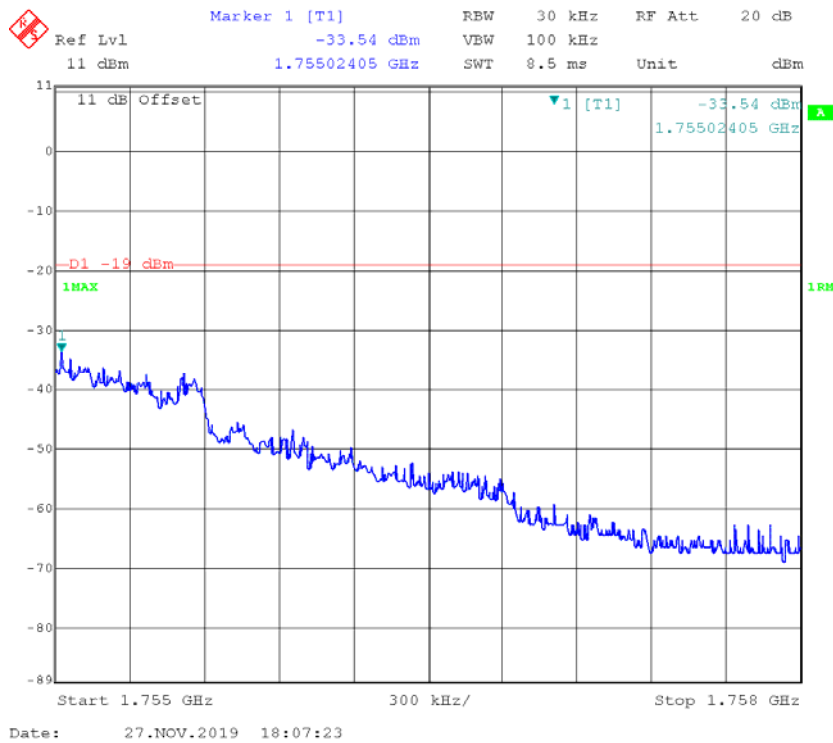

GSM Left Side Pre-AGC



GSM Left Side Above AGC



GSM Right Side Pre-AGC



GSM Right Side Above AGC



LTE Left Side Pre-AGC

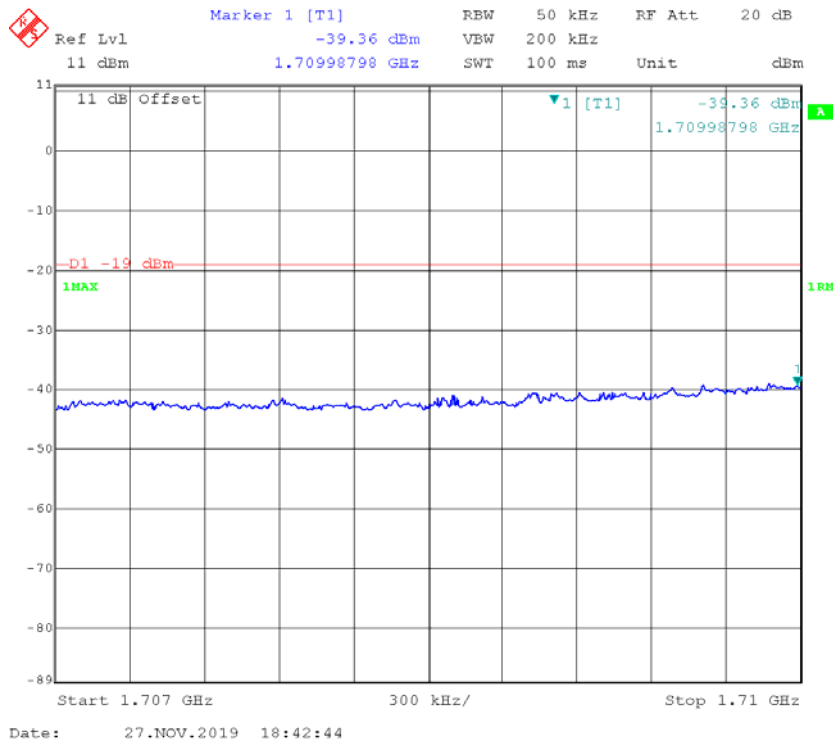

LTE Left Side Above AGC

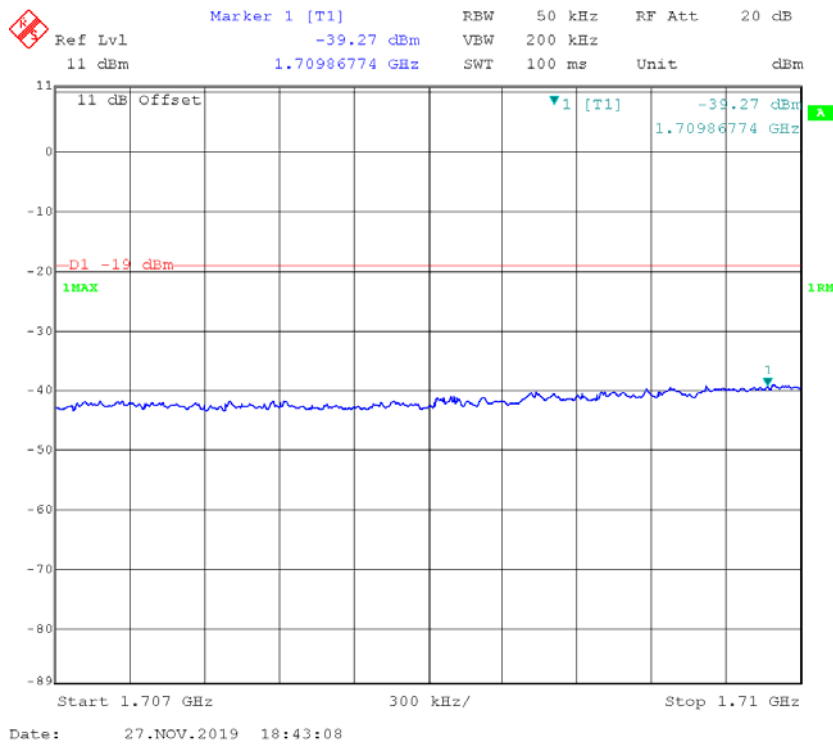

LTE Right Side Pre-AGC

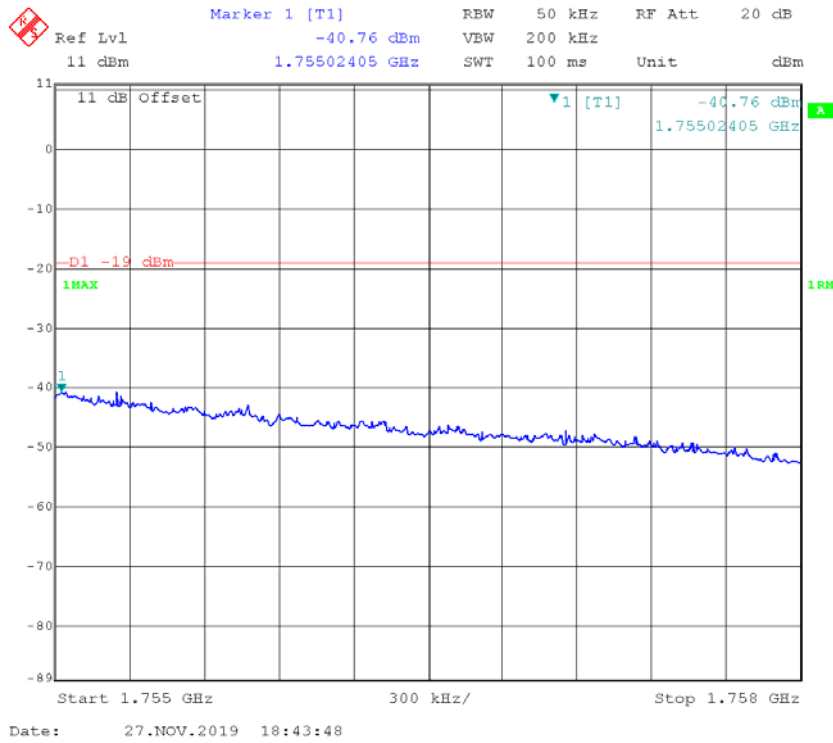

LTE Right Side Above AGC

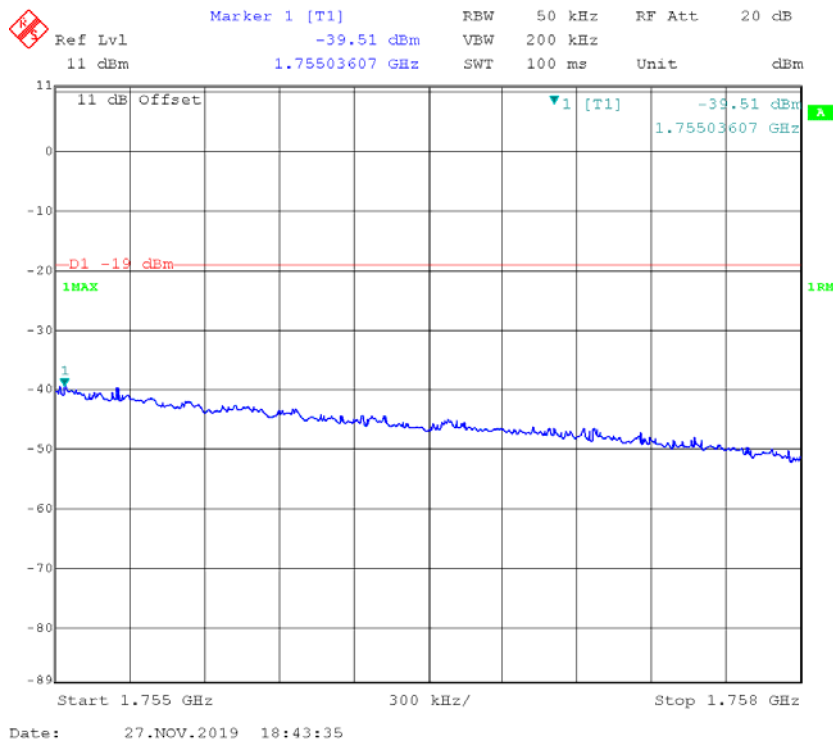

PCS Band:

CDMA Left Side Pre-AGC

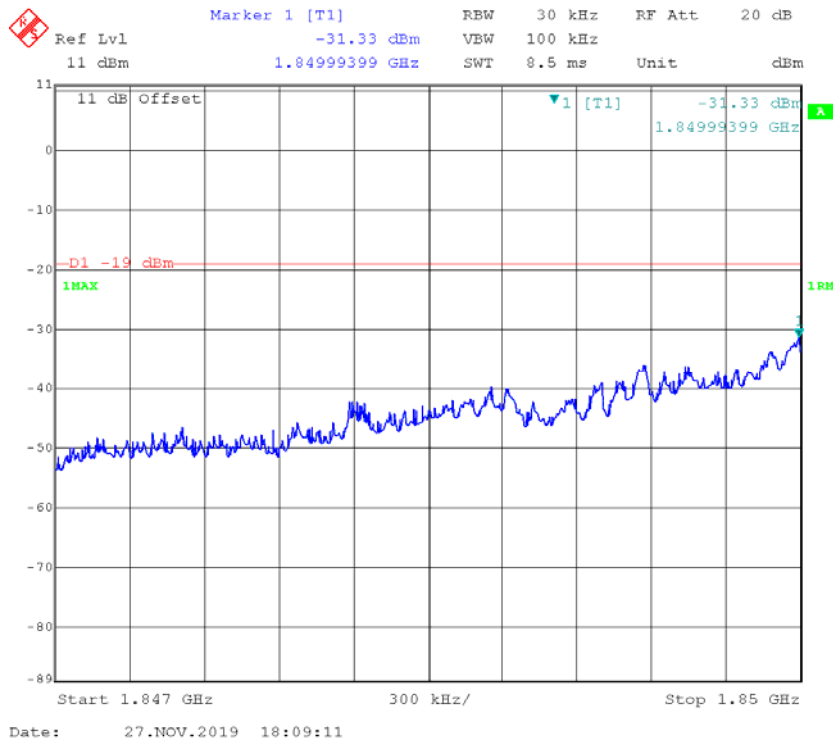

CDMA Left Side Above AGC

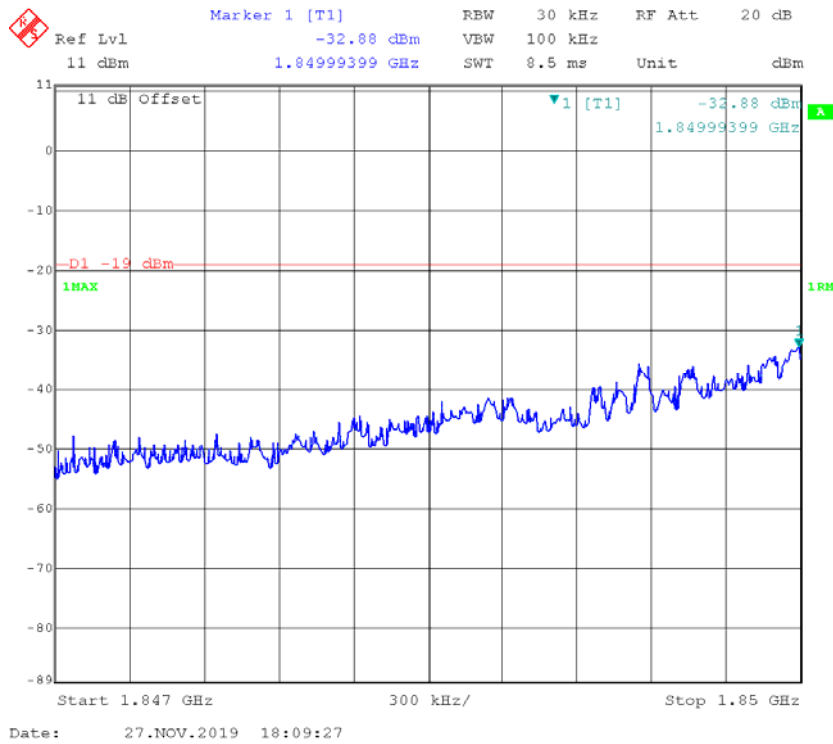

CDMA Right Side Pre-AGC

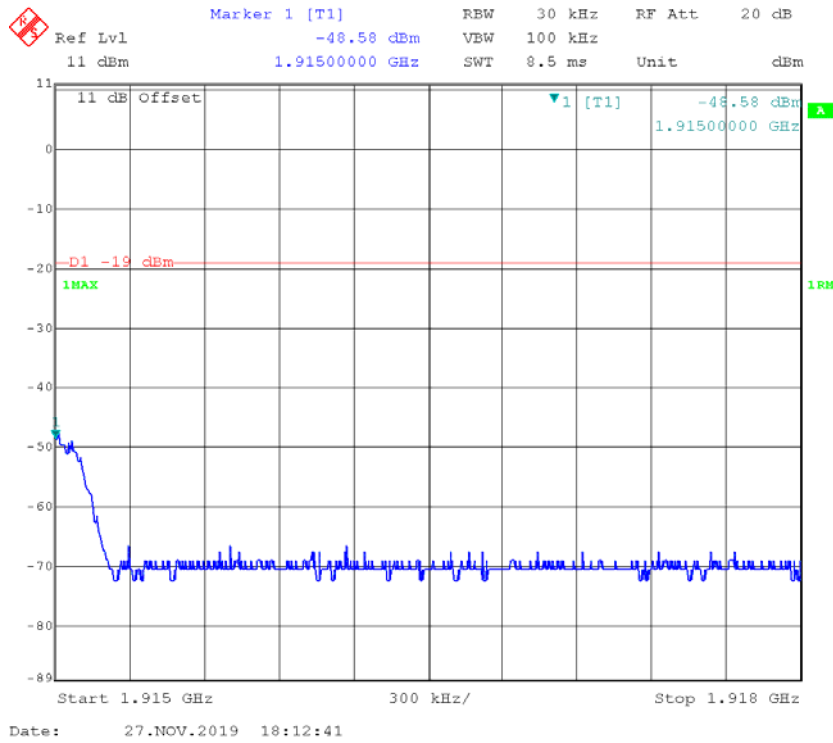

CDMA Right Side Above AGC

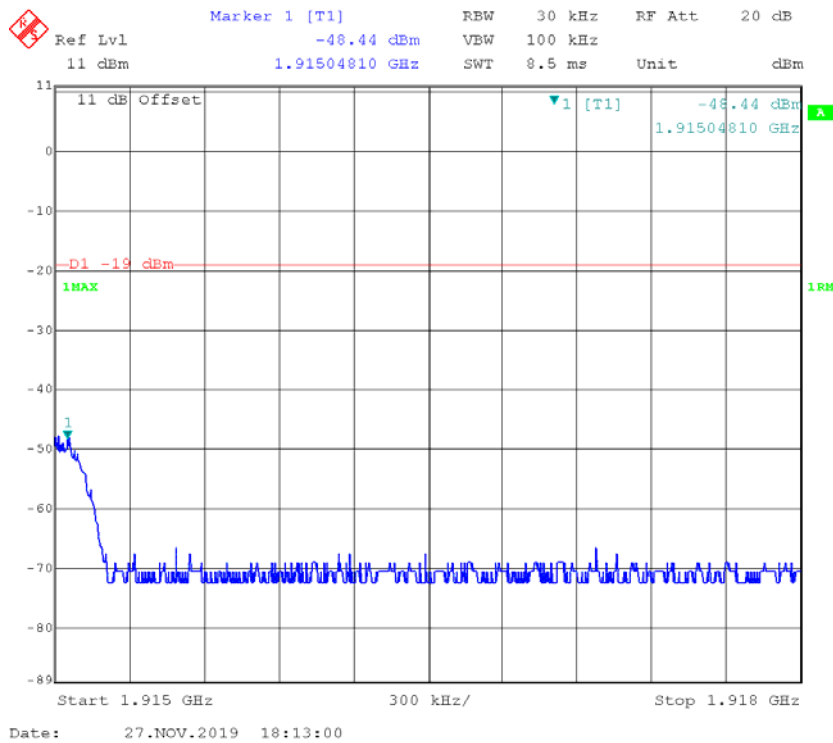

GSM Left Side Pre-AGC

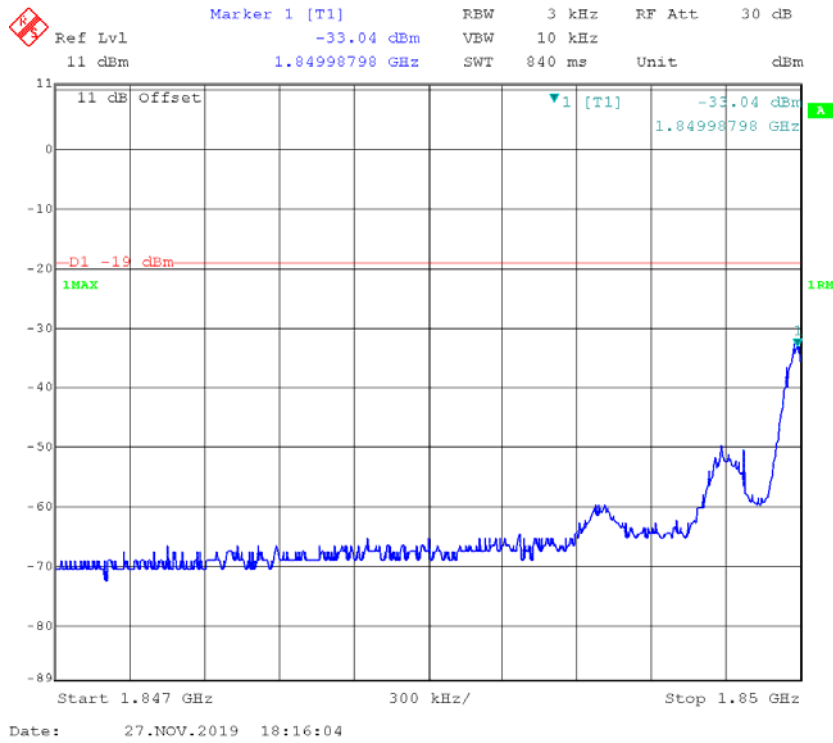

GSM Left Side Above AGC

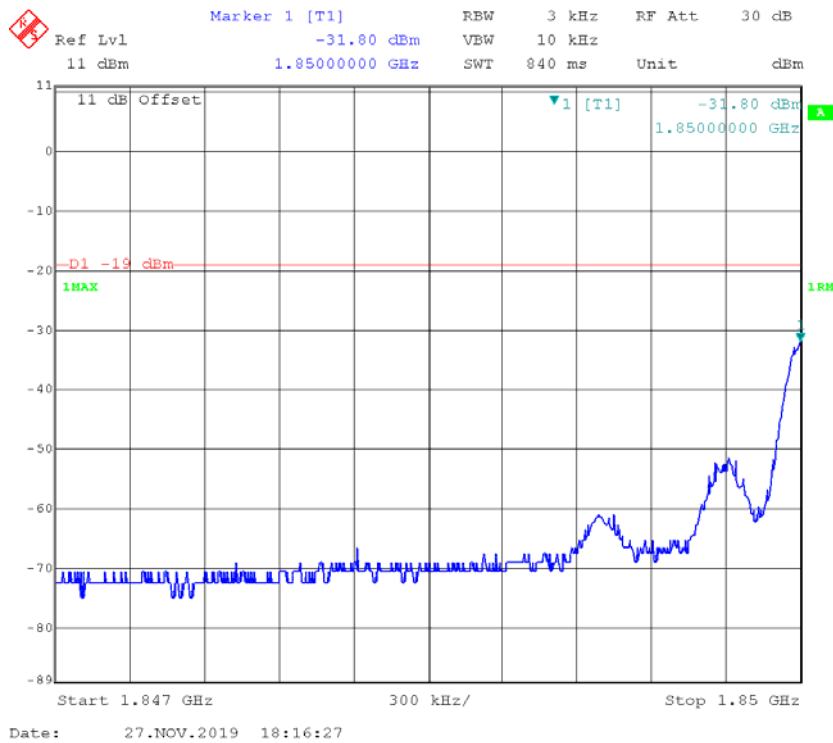

GSM Right Side Pre-AGC



GSM Right Side Above AGC

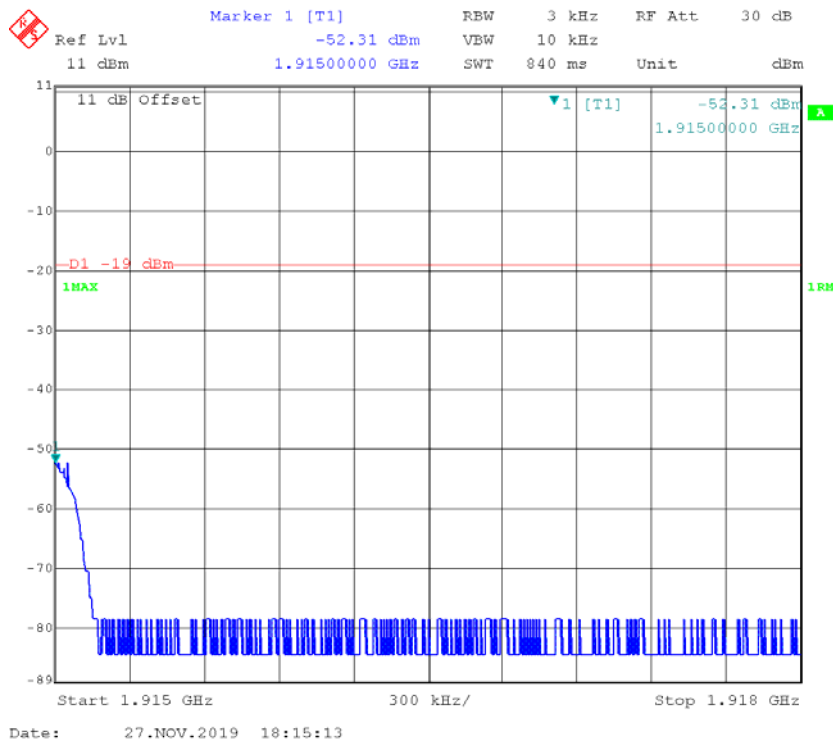

LTE Left Side Pre-AGC

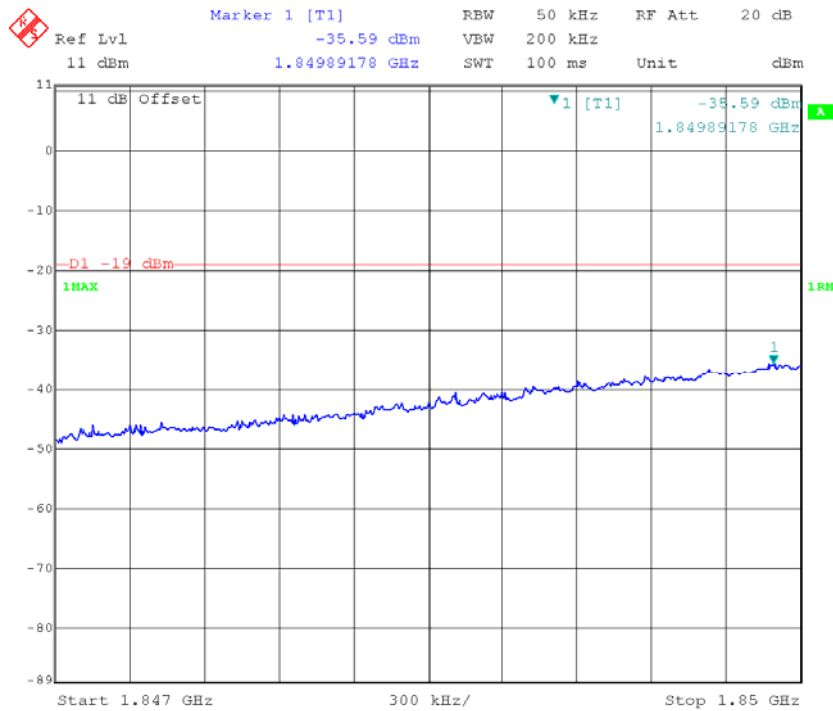

Date: 27.NOV.2019 18:44:38

LTE Left Side Above AGC

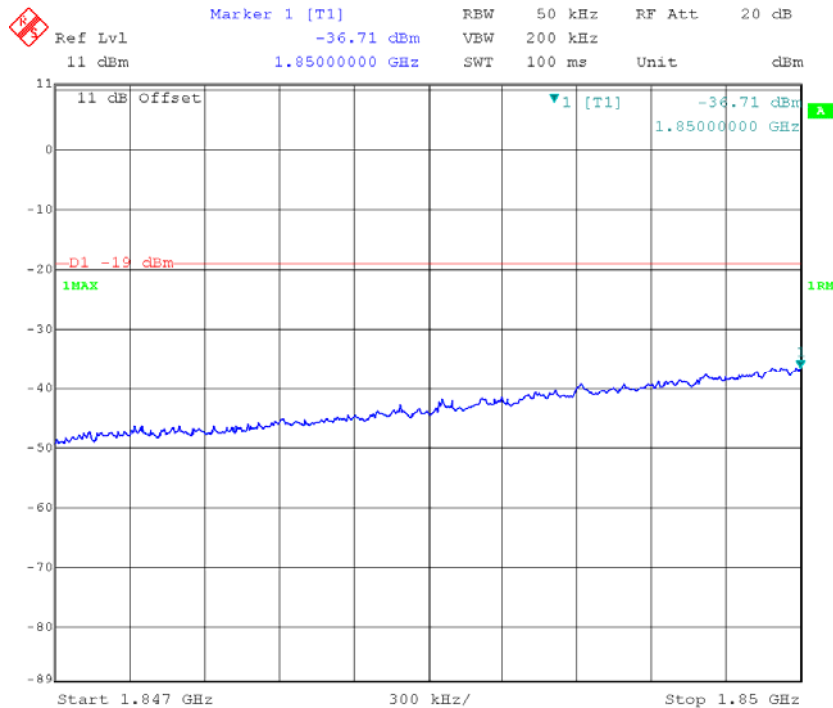

Date: 27.NOV.2019 18:44:56

LTE Right Side Pre-AGC

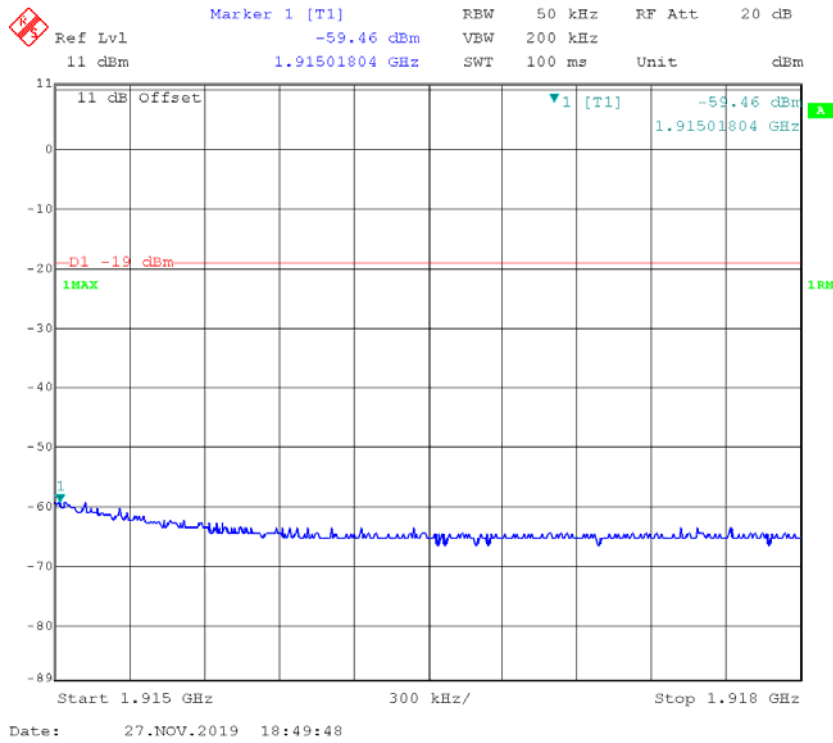

LTE Right Side Above AGC

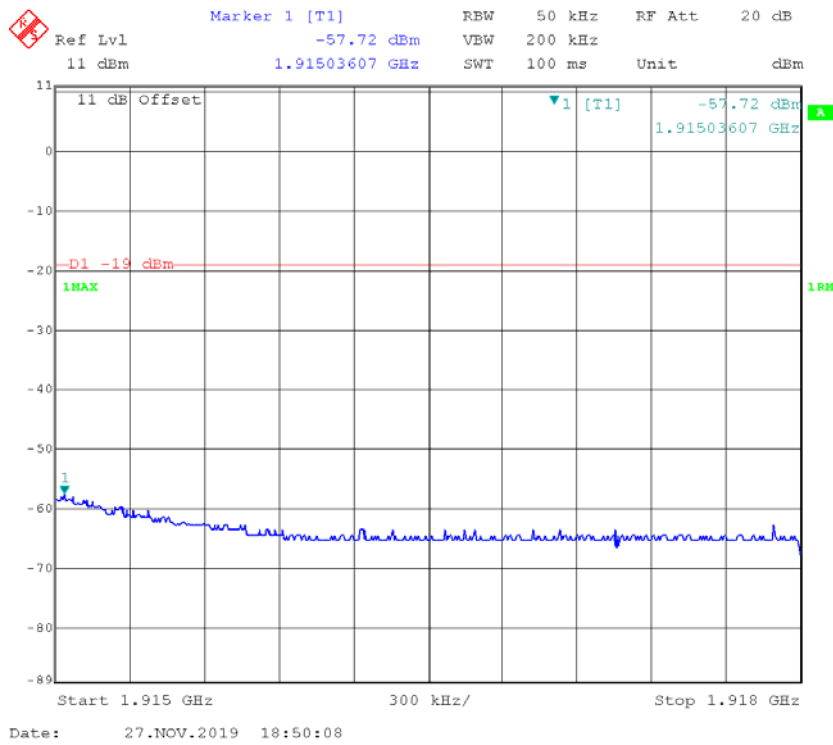

GSM Right Side Pre-AGC

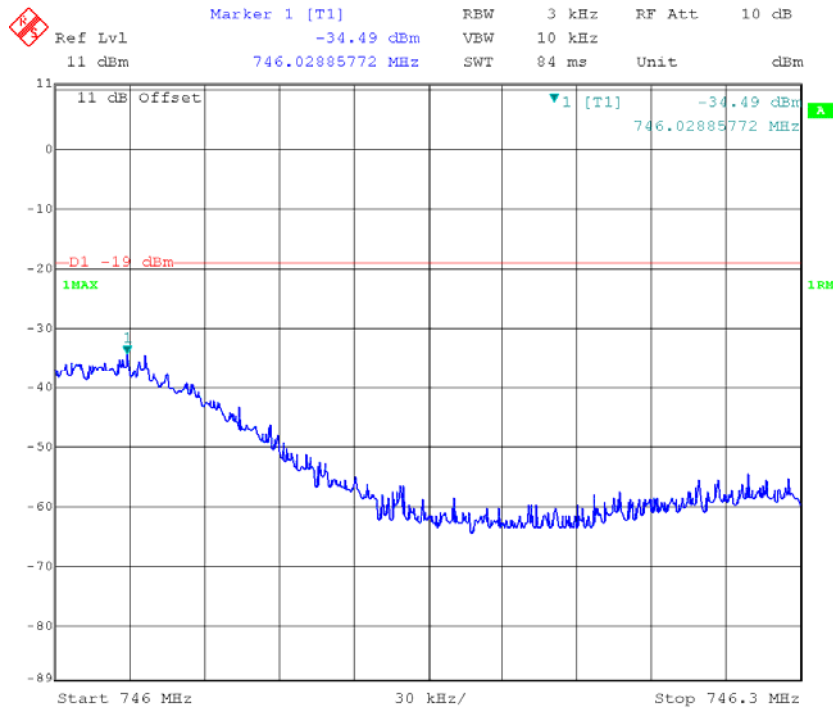

GSM Right Side Above AGC

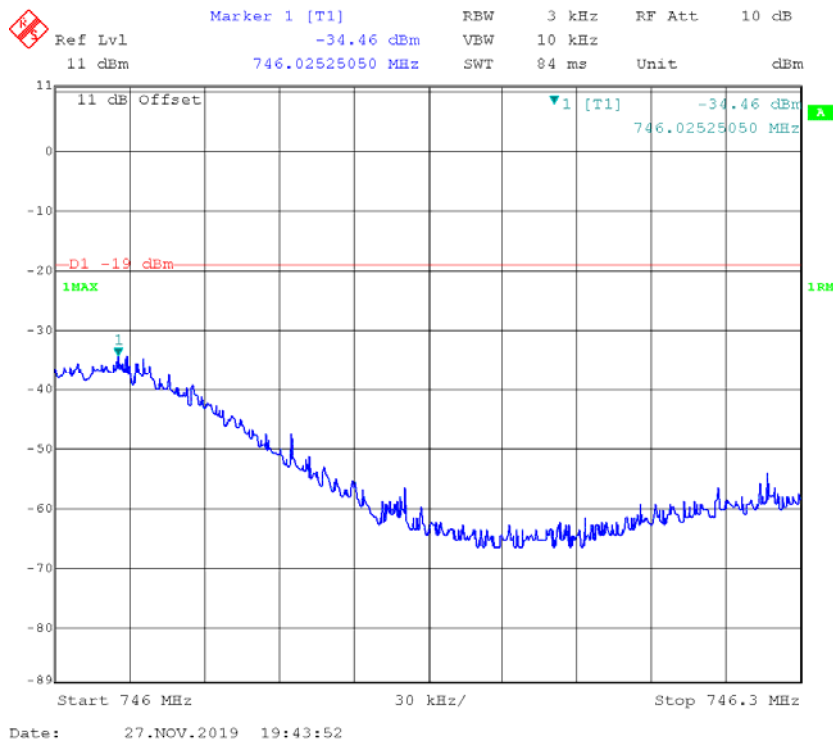

LTE Left Side Pre-AGC

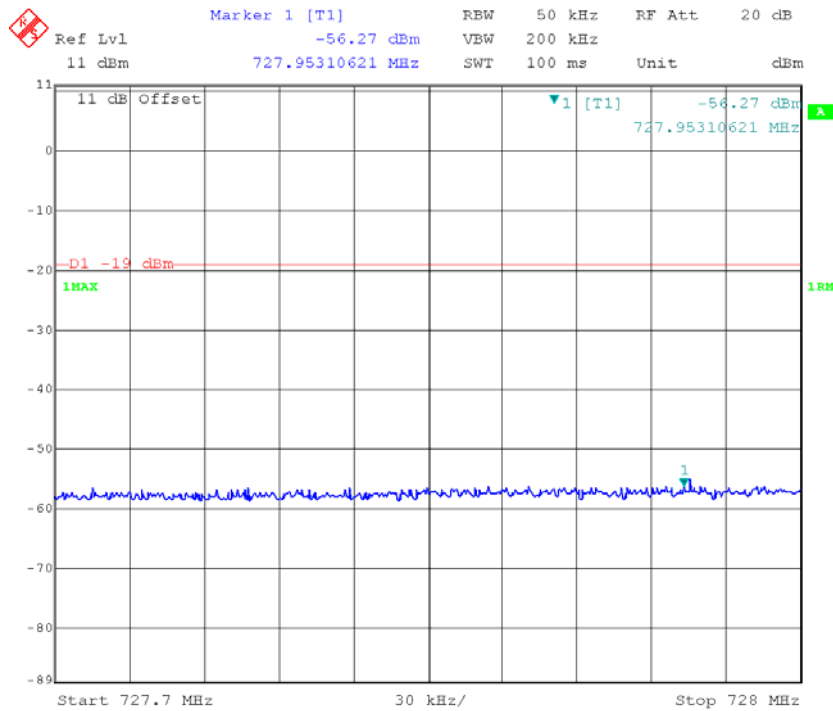

Date: 27.NOV.2019 18:57:18

LTE Left Side Above AGC

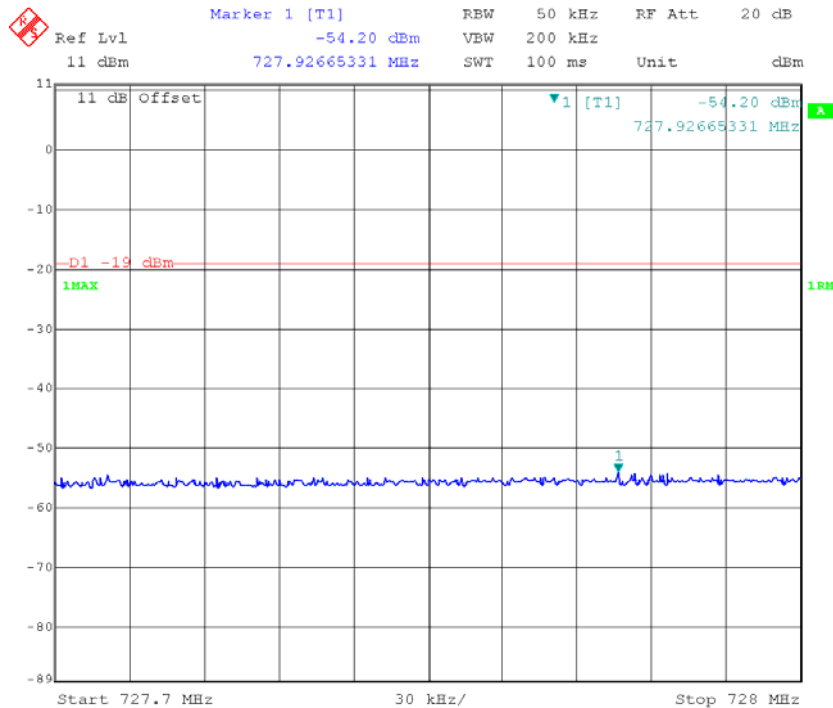

Date: 27.NOV.2019 18:57:03

LTE Right Side Pre-AGC

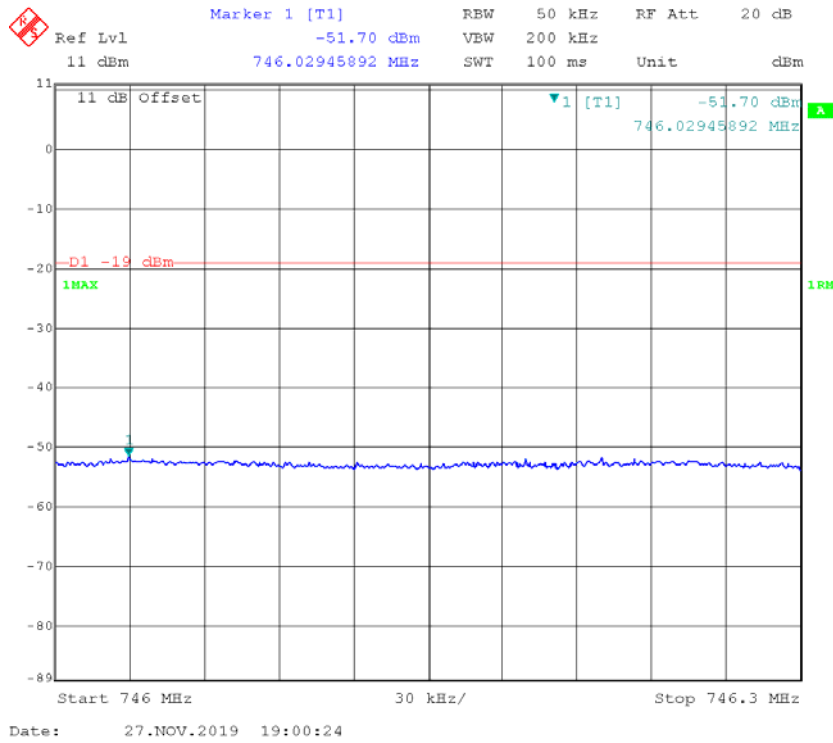

LTE Right Side Above AGC

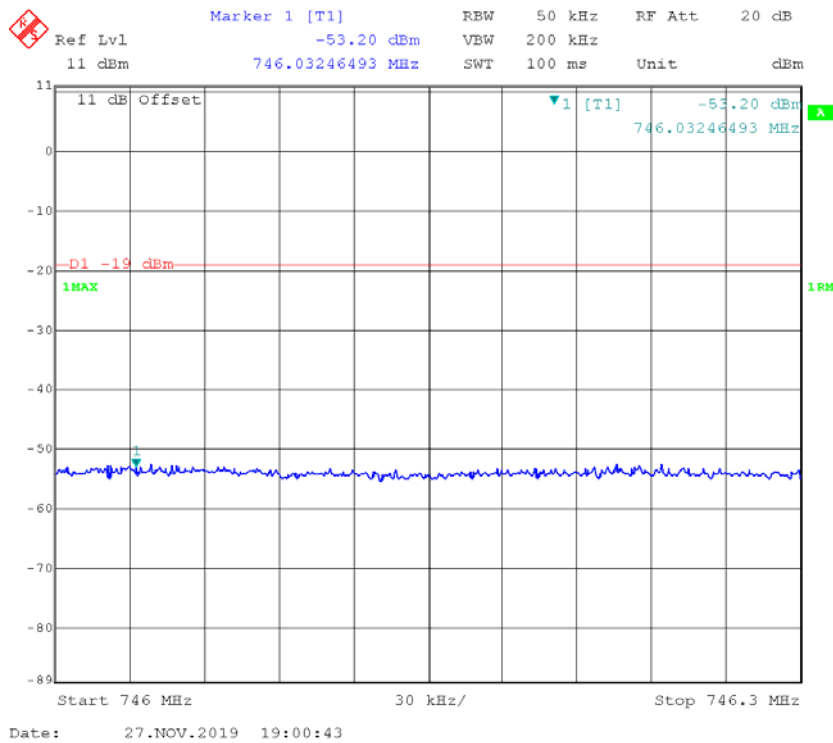

Upper 700MHz Band:

CDMA Left Side Pre-AGC

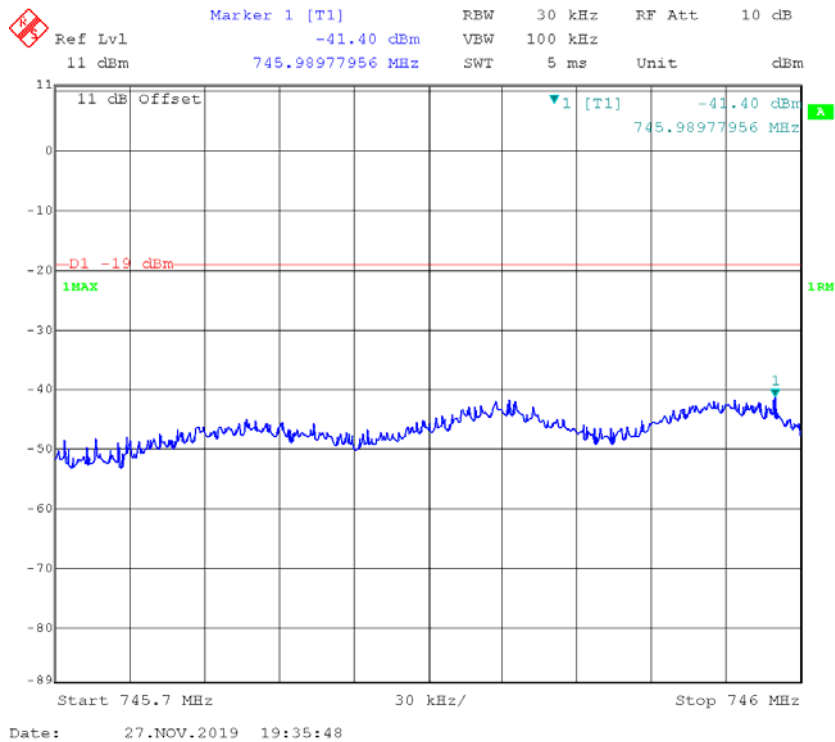

CDMA Left Side Above AGC

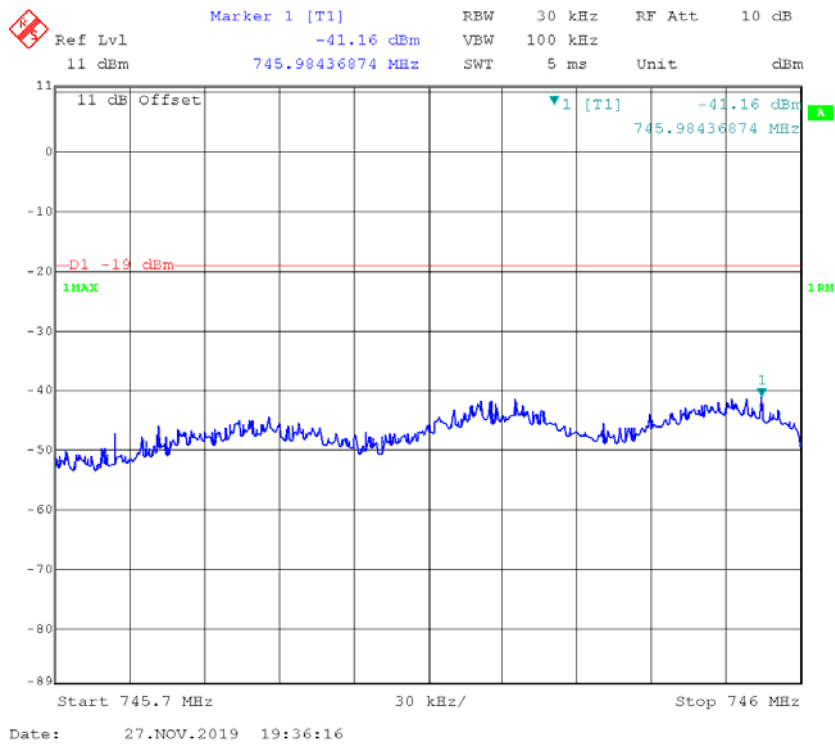

CDMA Right Side Pre-AGC

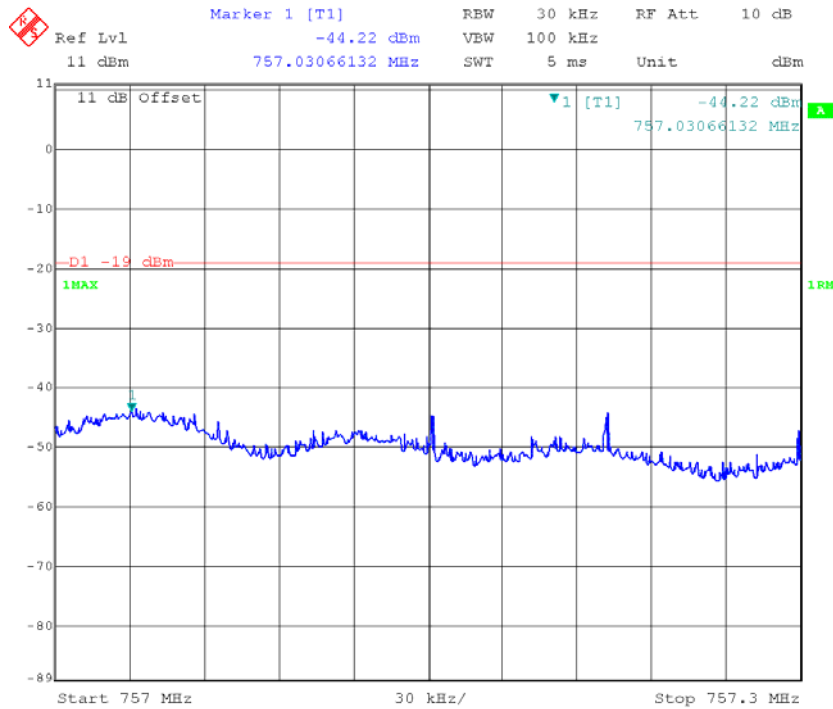

CDMA Right Side Above AGC

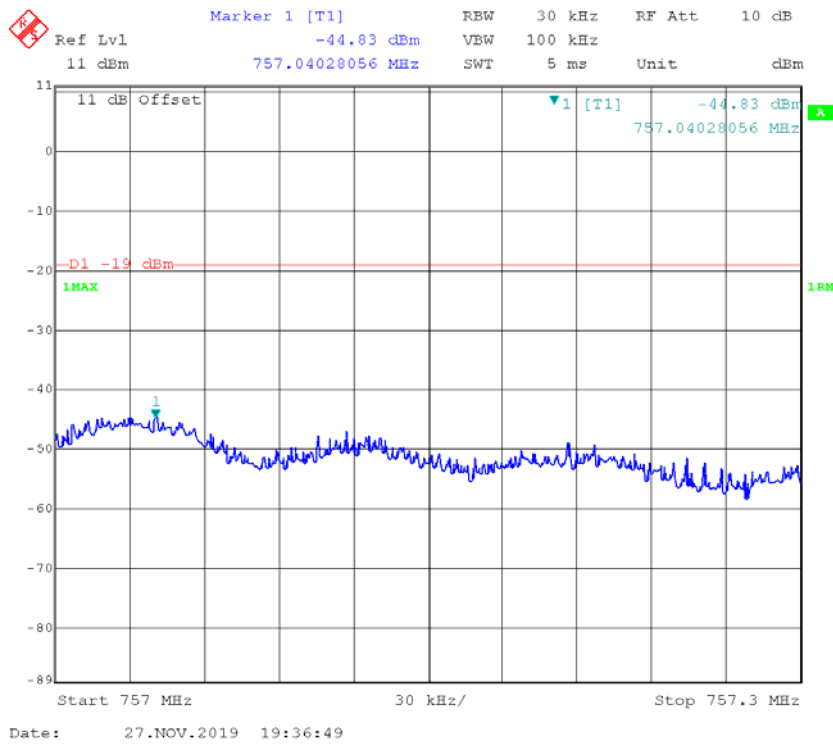

GSM Left Side Pre-AGC

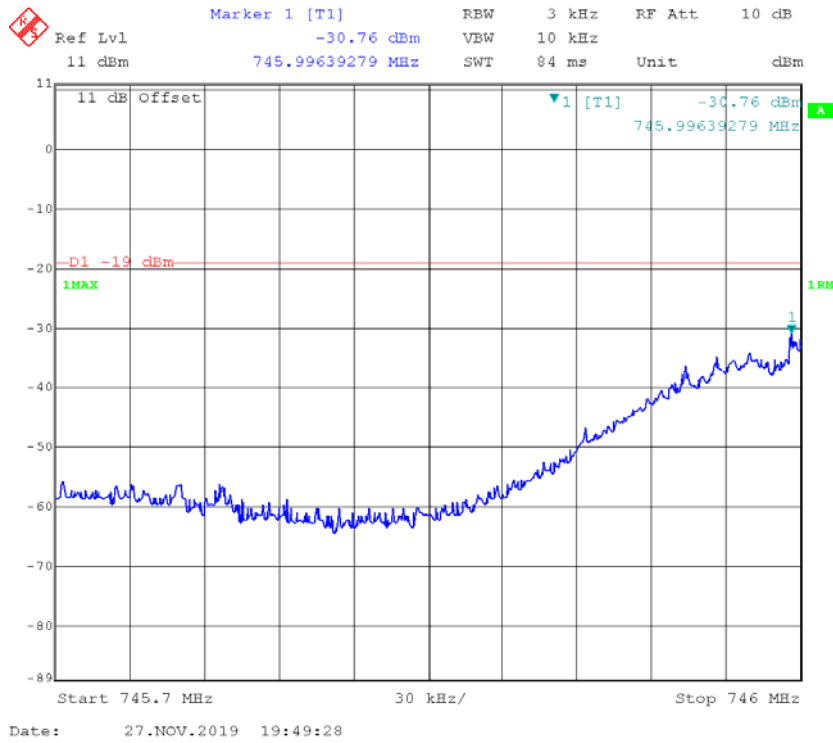

GSM Left Side Above AGC

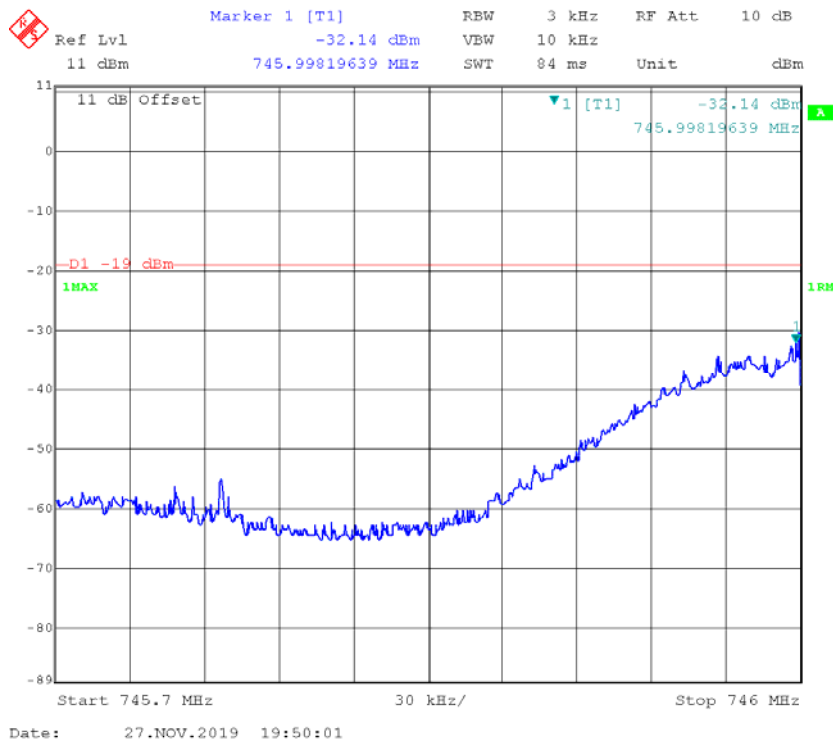

GSM Right Side Pre-AGC



Date: 27.NOV.2019 19:51:12

GSM Right Side Above AGC

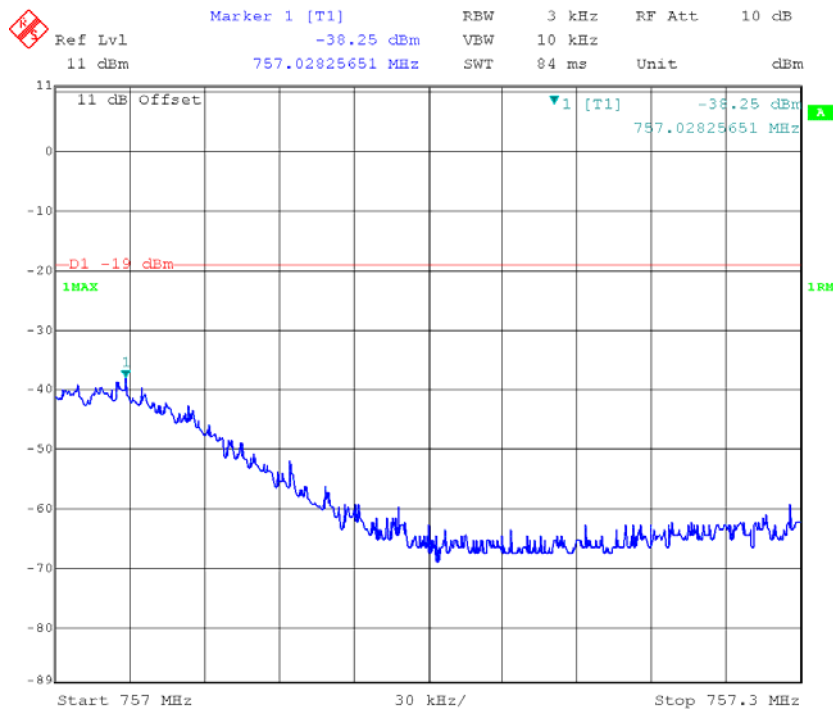

Date: 27.NOV.2019 19:51:27

LTE Left Side Pre-AGC

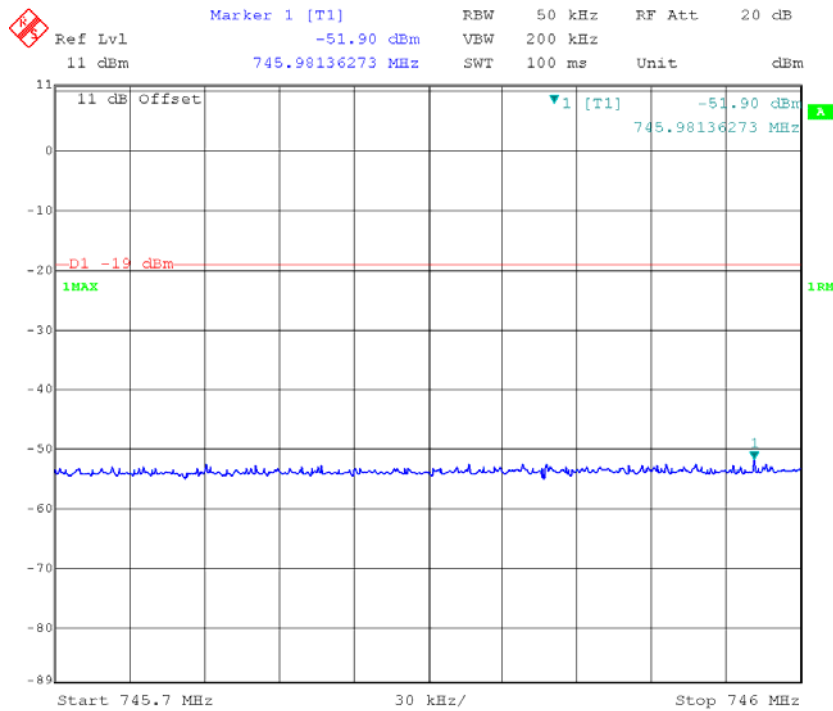

Date: 27.NOV.2019 19:02:47

LTE Left Side Above AGC

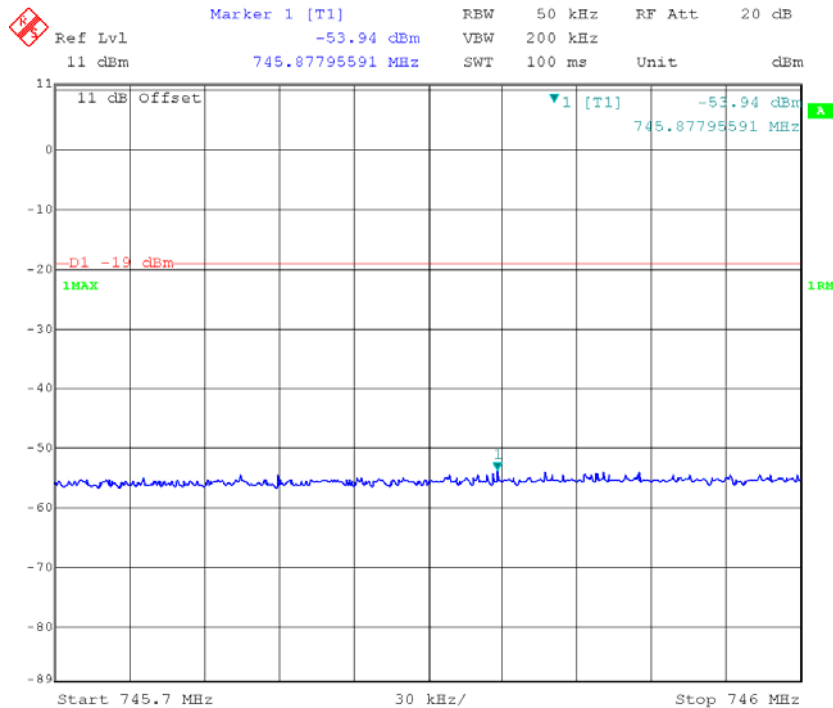

Date: 27.NOV.2019 19:03:03

LTE Right Side Pre-AGC

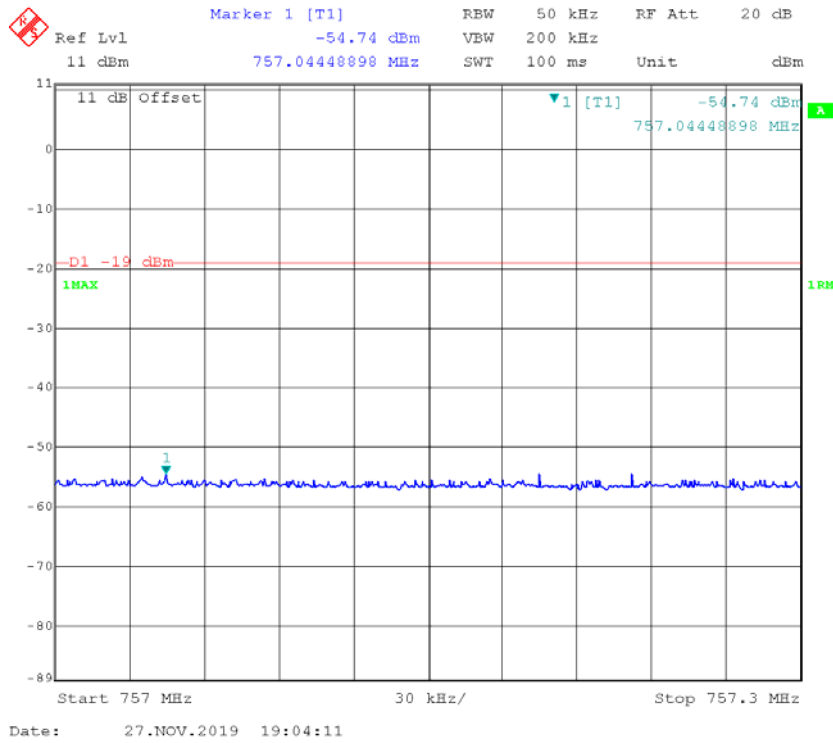

LTE Right Side Above AGC

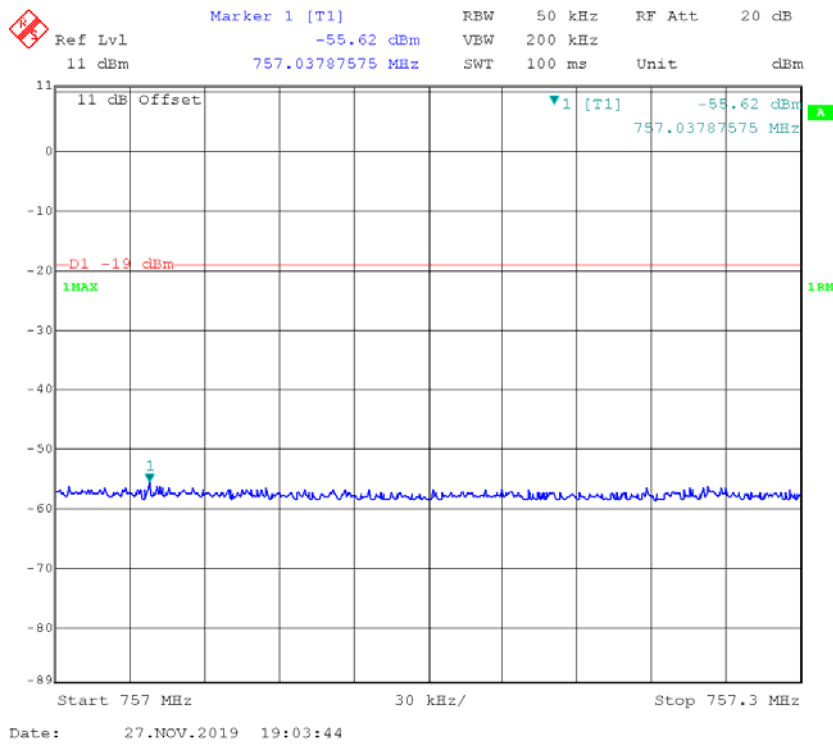

Cellular Band:

CDMA Left Side Pre-AGC

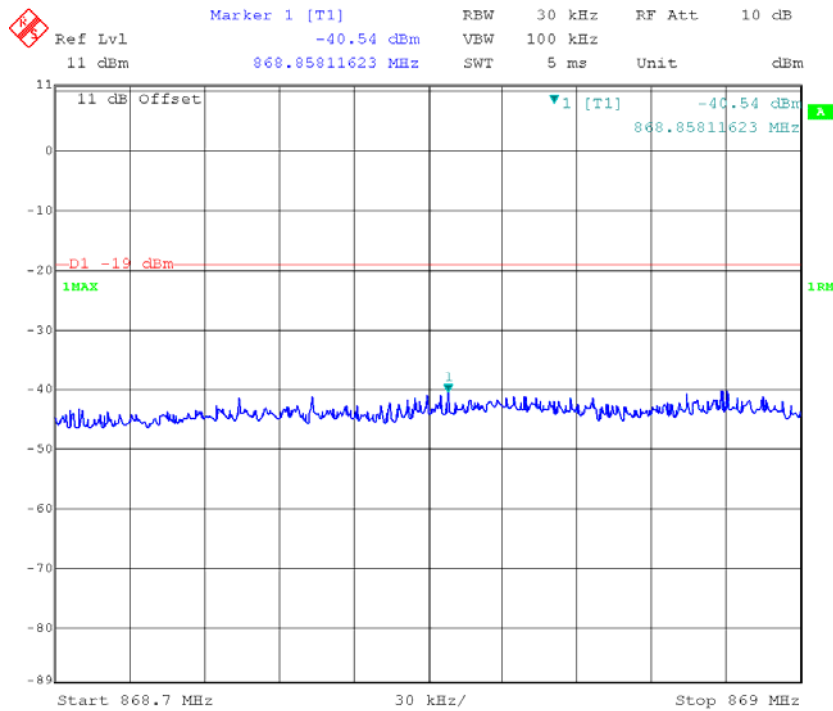

Date: 27.NOV.2019 19:32:36

CDMA Left Side Above AGC



Date: 27.NOV.2019 19:32:59

CDMA Right Side Pre-AGC

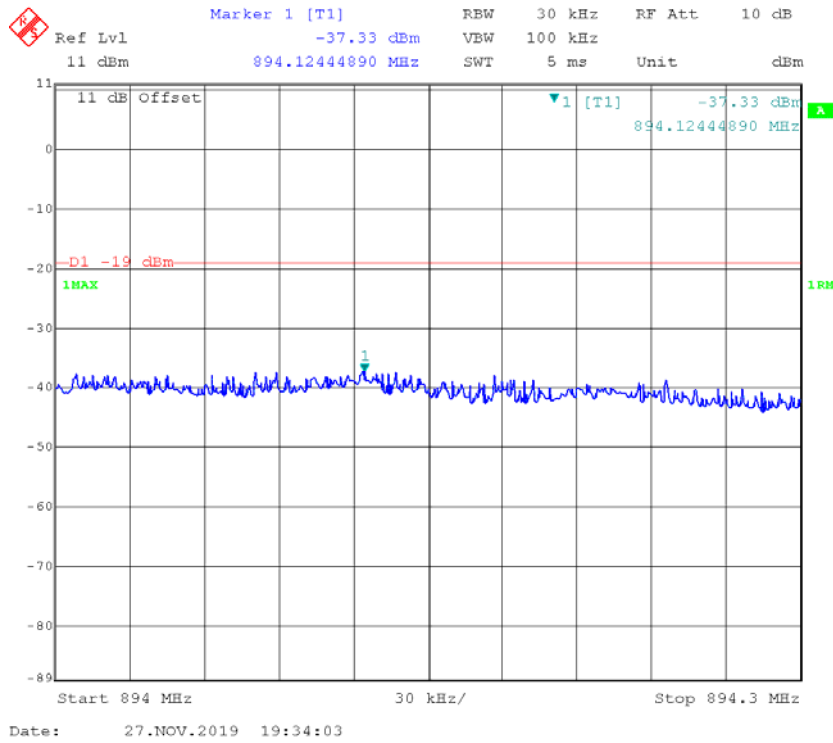

CDMA Right Side Above AGC

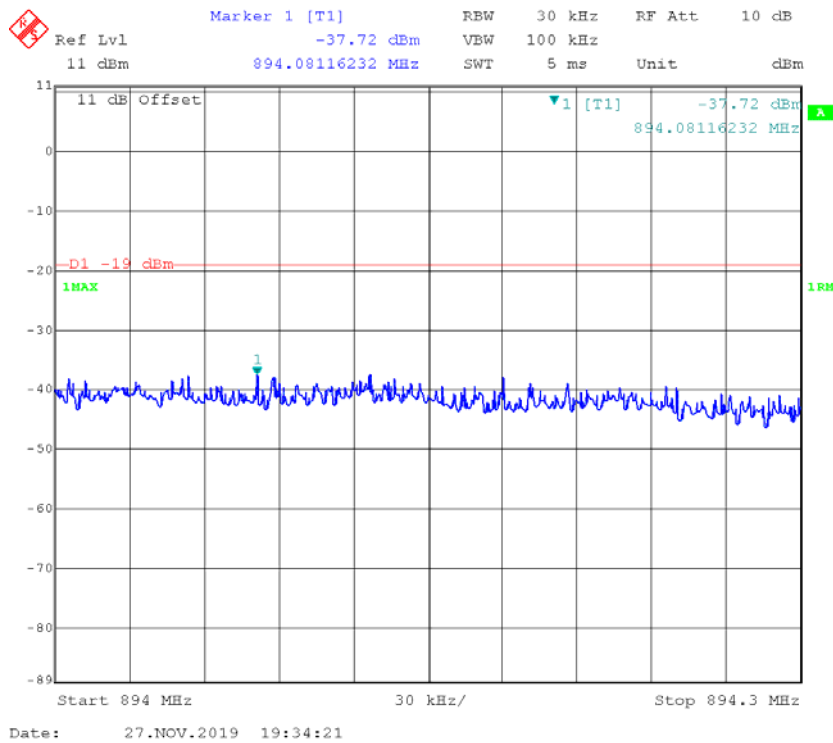

GSM Left Side Pre-AGC

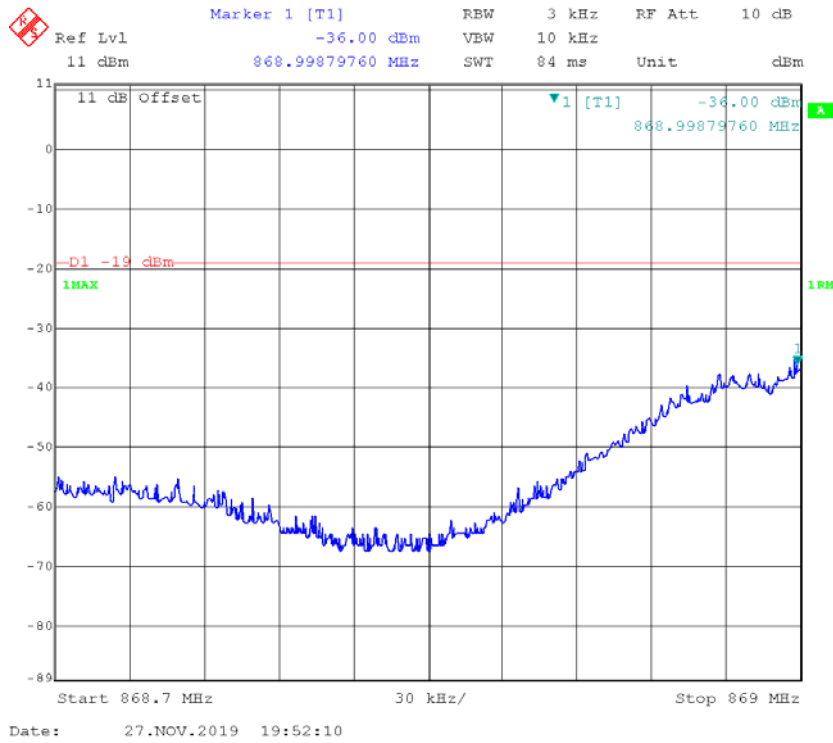

GSM Left Side Above AGC

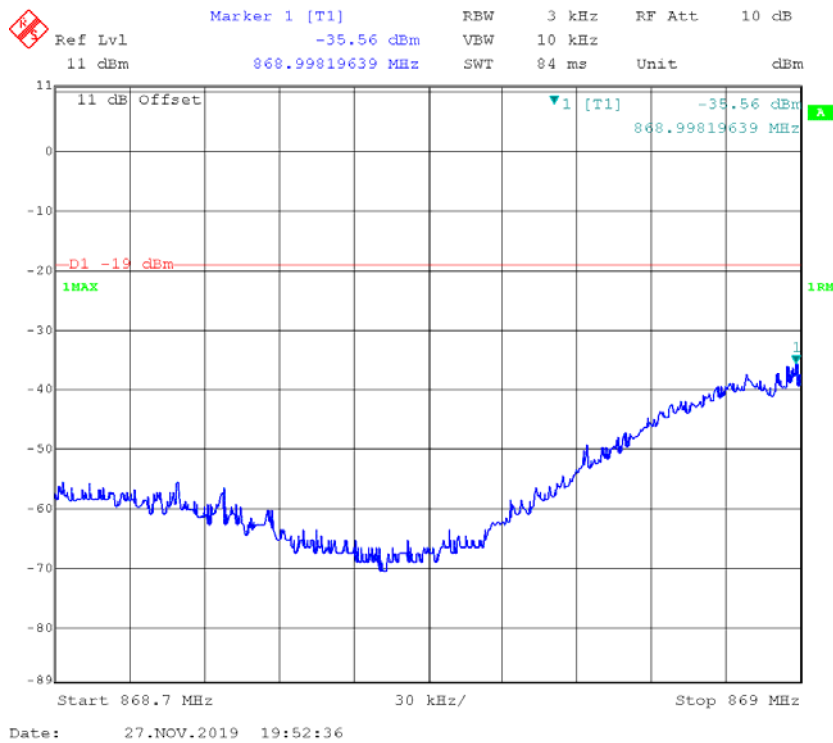

GSM Right Side Pre-AGC



Date: 27.NOV.2019 19:53:35

GSM Right Side Above AGC



Date: 27.NOV.2019 19:53:12

LTE Left Side Pre-AGC

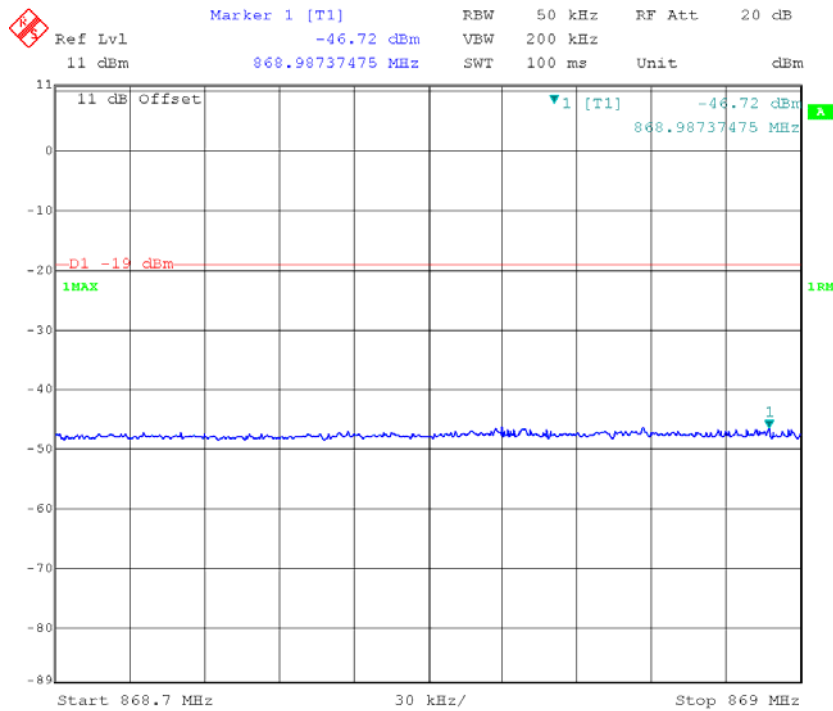

Date: 27.NOV.2019 19:05:04

LTE Left Side Above AGC

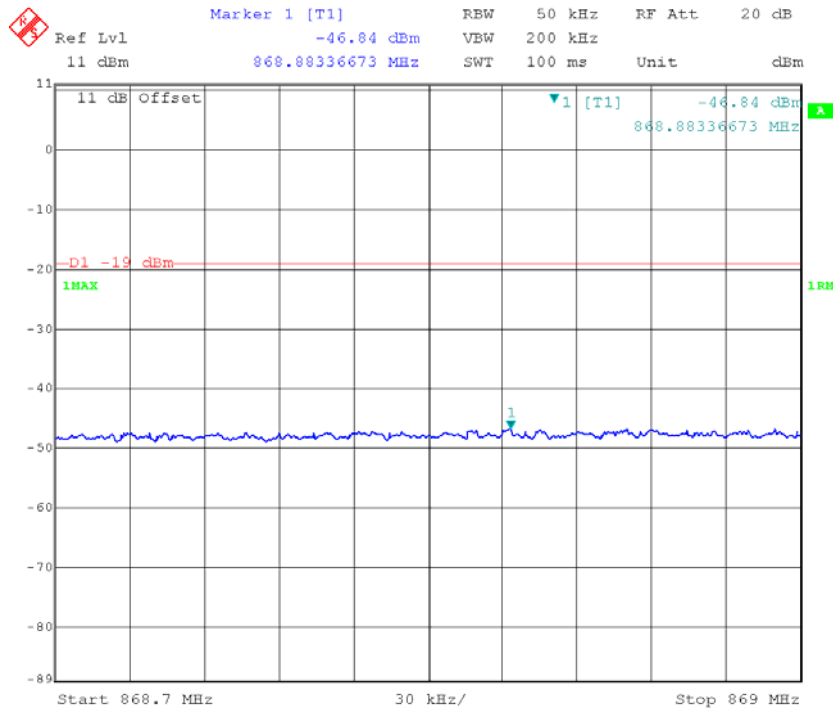

Date: 27.NOV.2019 19:05:20

LTE Right Side Pre-AGC

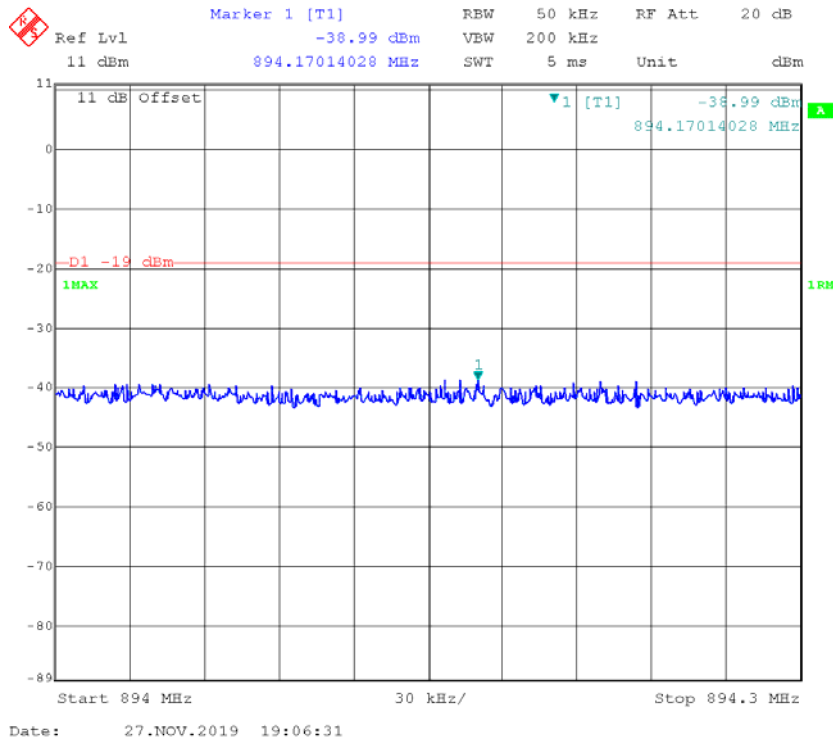

LTE Right Side Above AGC

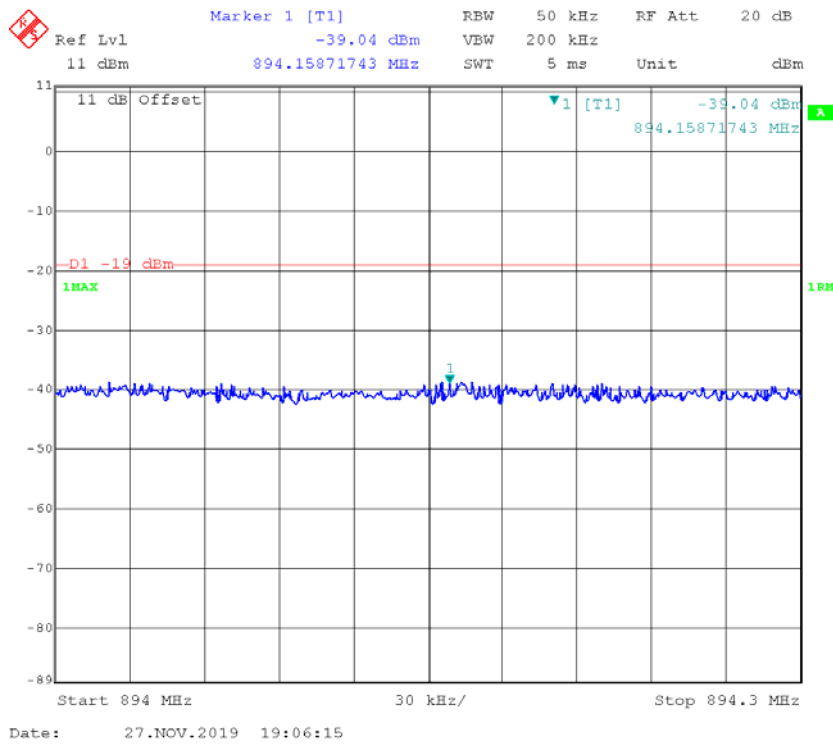

AWS Band:

CDMA Left Side Pre-AGC

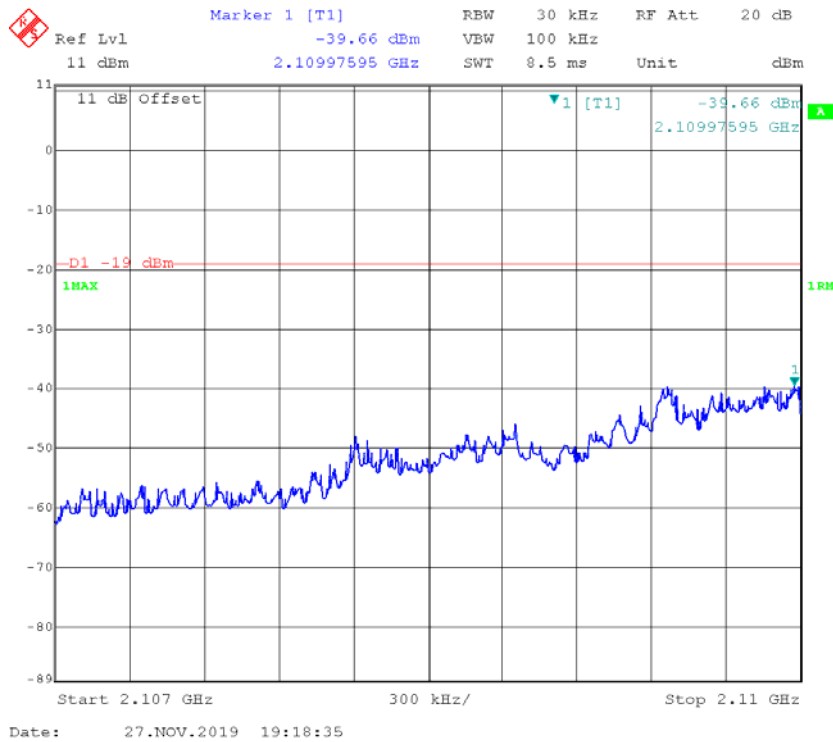

CDMA Left Side Above AGC

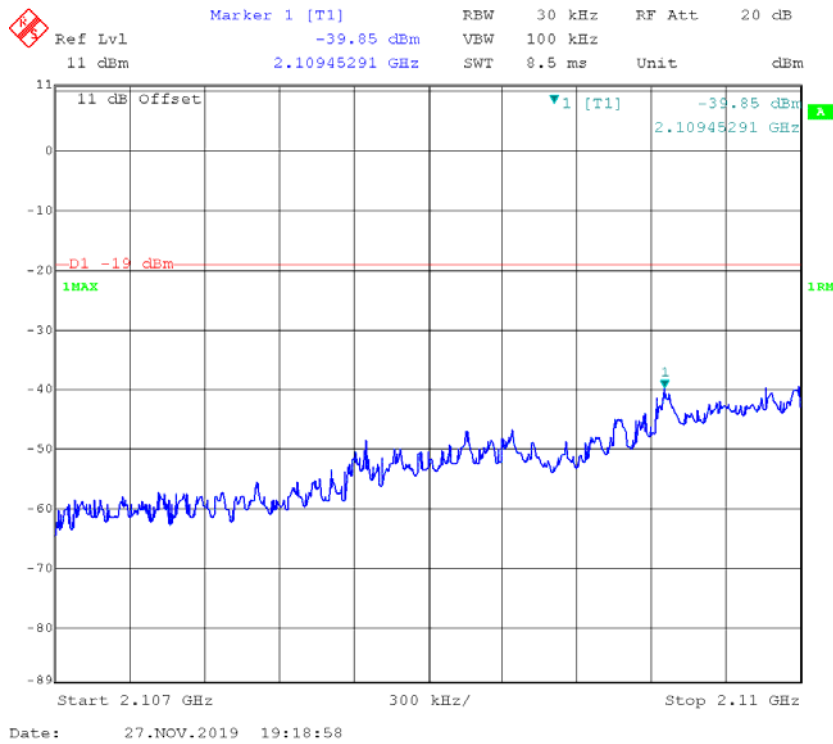

CDMA Right Side Pre-AGC

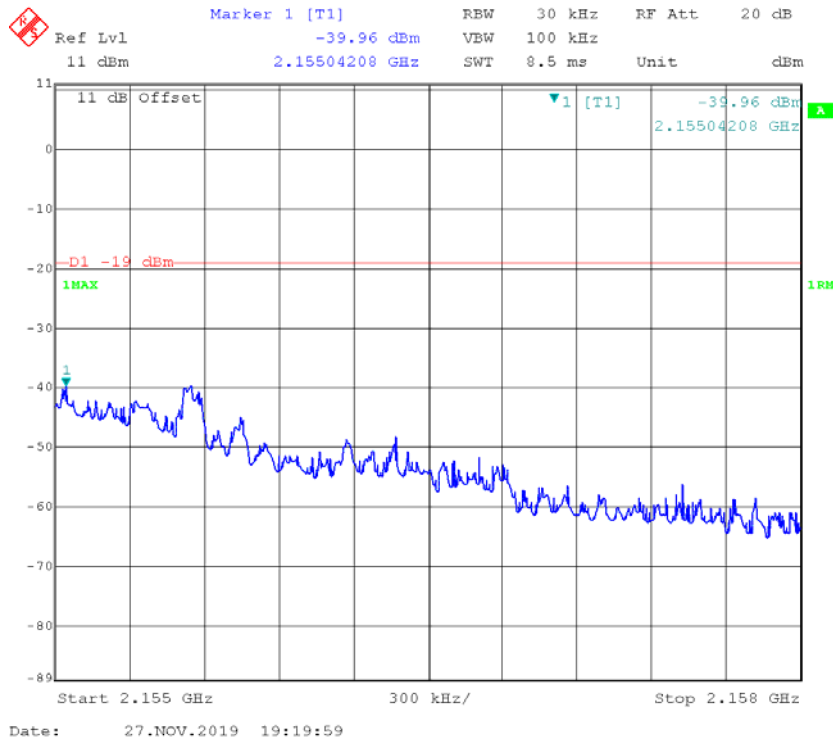

CDMA Right Side Above AGC

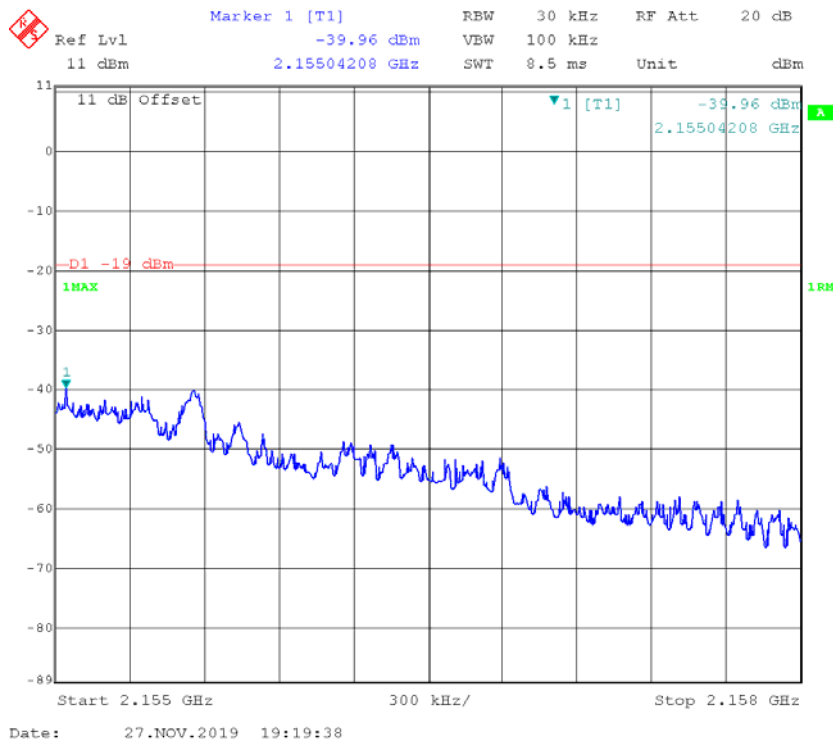

GSM Left Side Pre-AGC



GSM Left Side Above AGC



GSM Right Side Pre-AGC

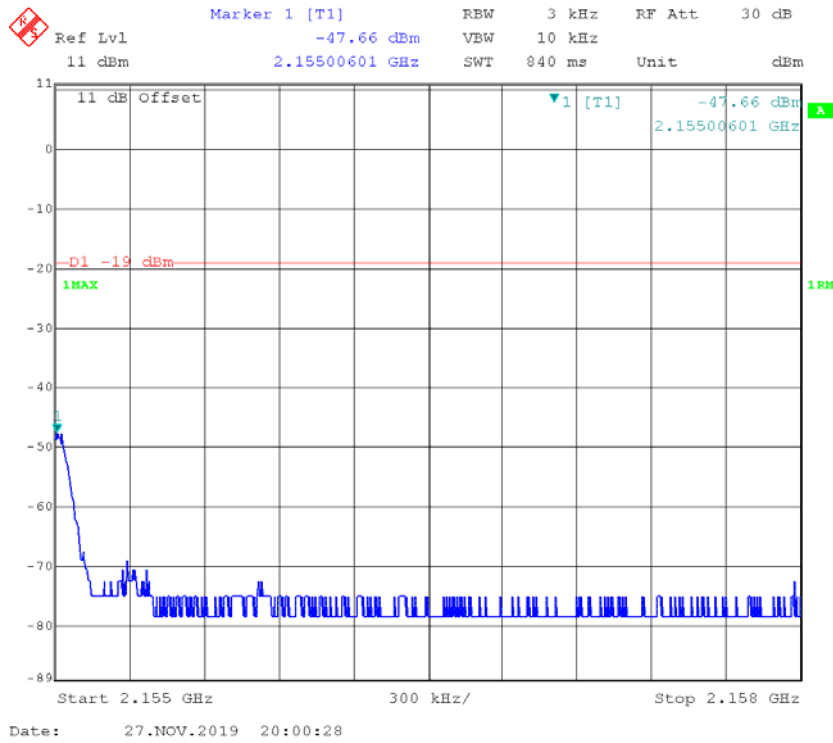

GSM Right Side Above AGC



LTE Left Side Pre-AGC

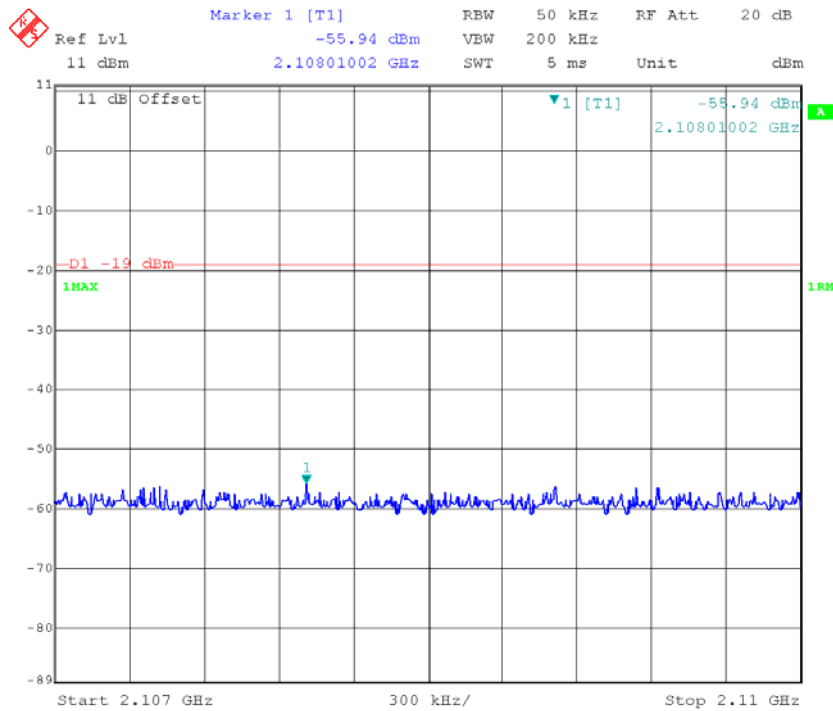

Date: 27.NOV.2019 19:07:38

LTE Left Side Above AGC

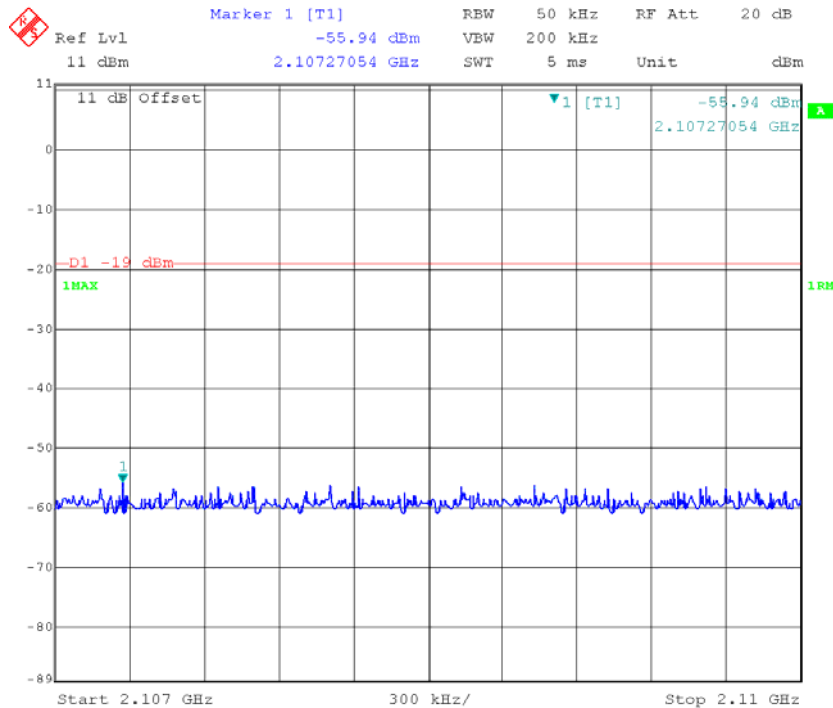

Date: 27.NOV.2019 19:08:01

LTE Right Side Pre-AGC

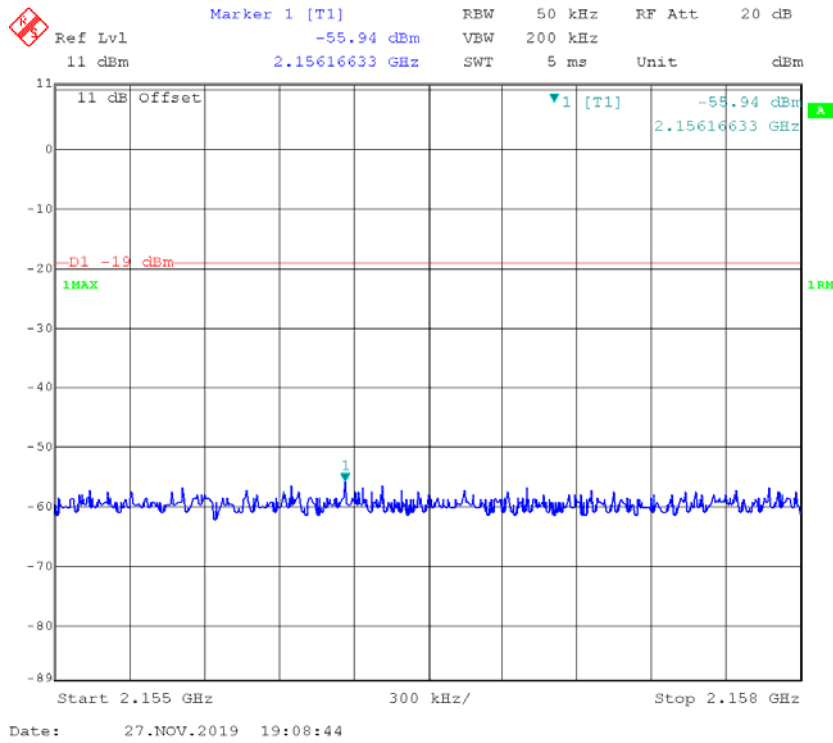

LTE Right Side Above AGC

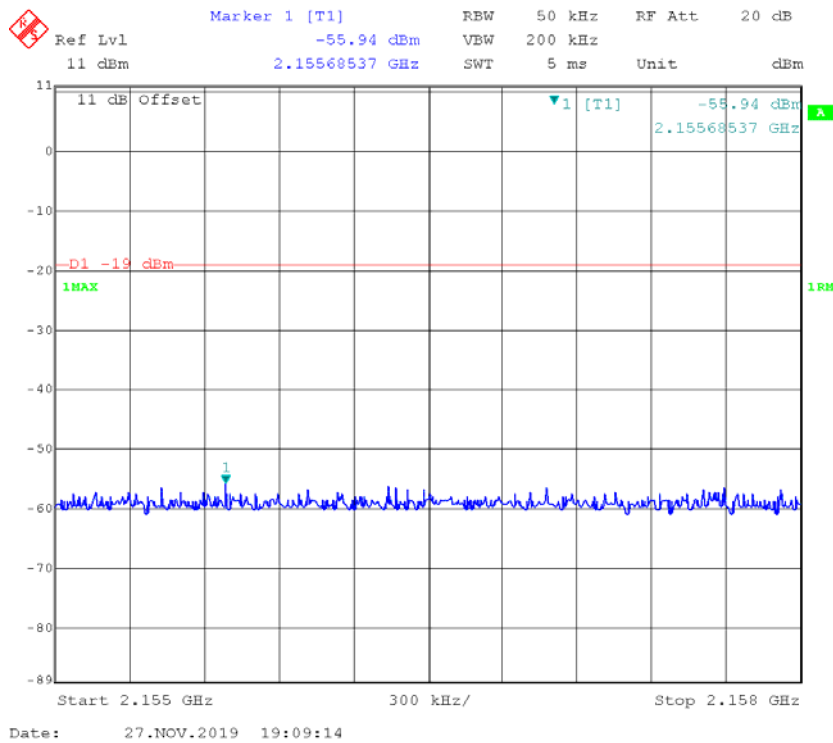

PCS Band:

CDMA Left Side Pre-AGC

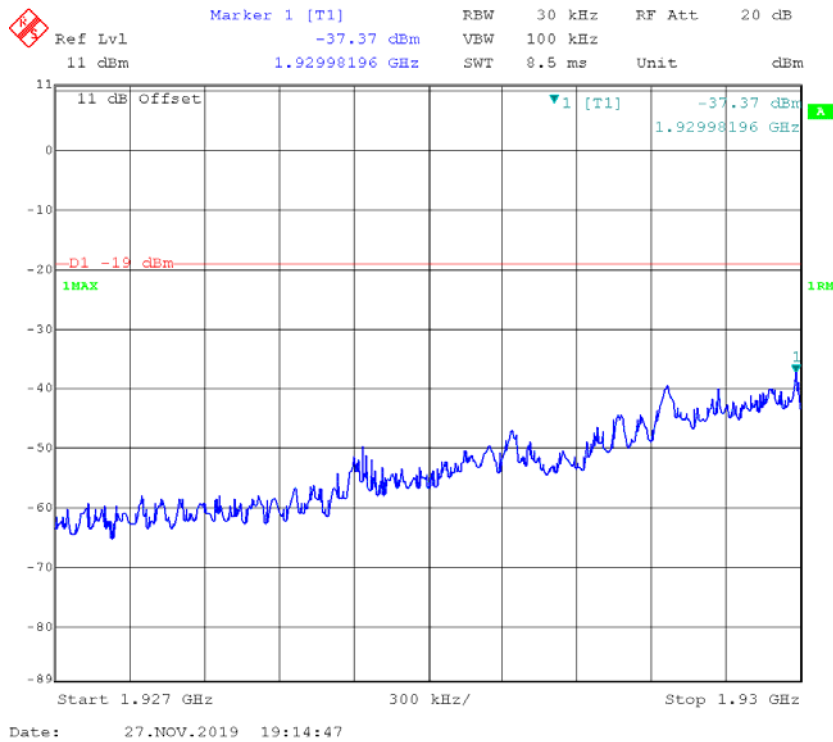

CDMA Left Side Above AGC

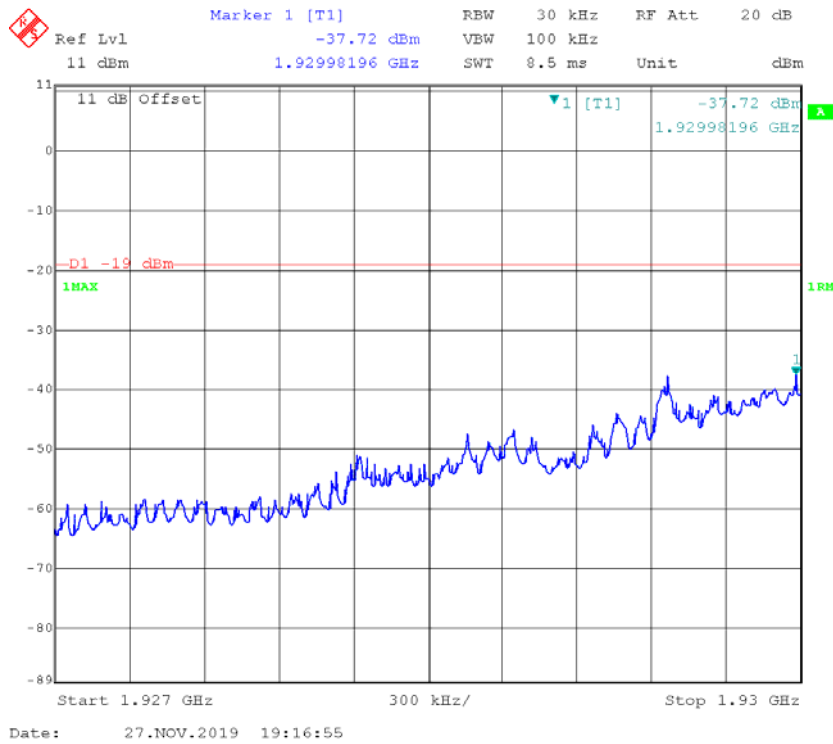

CDMA Right Side Pre-AGC

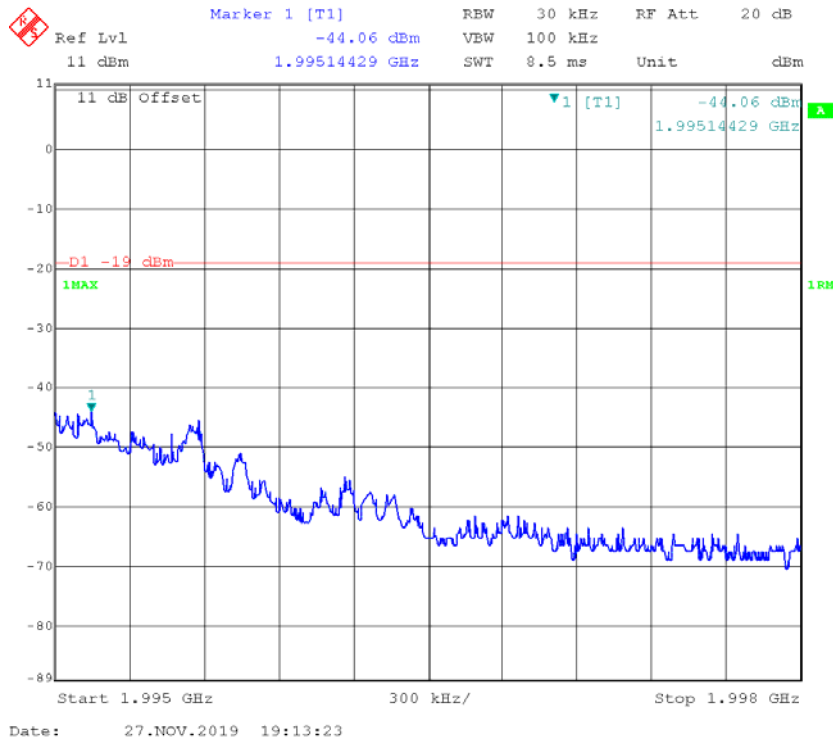

CDMA Right Side Above AGC

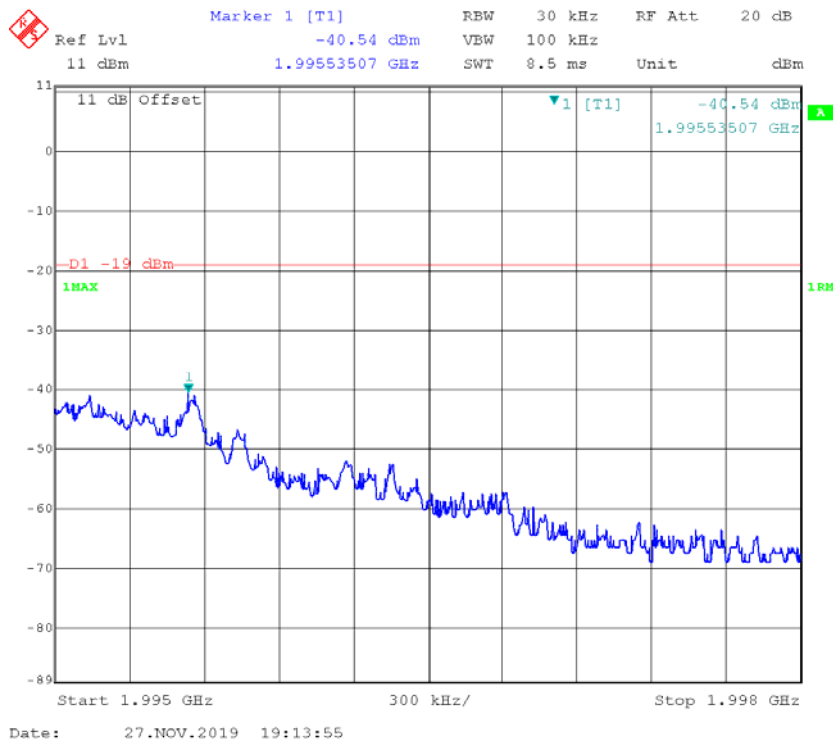

GSM Left Side Pre-AGC



GSM Left Side Above AGC



GSM Right Side Pre-AGC



GSM Right Side Above AGC

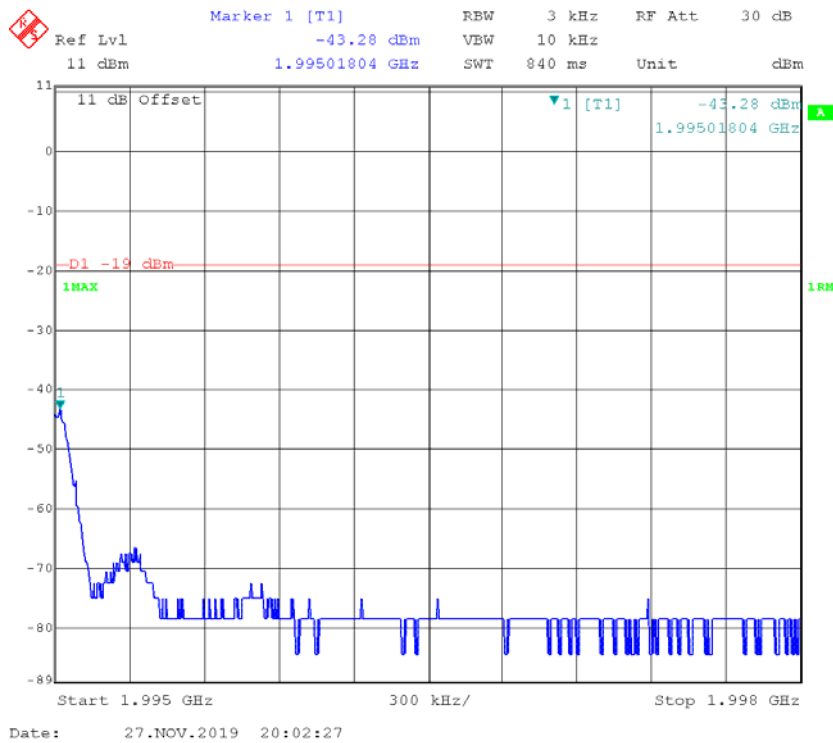

LTE Left Side Pre-AGC

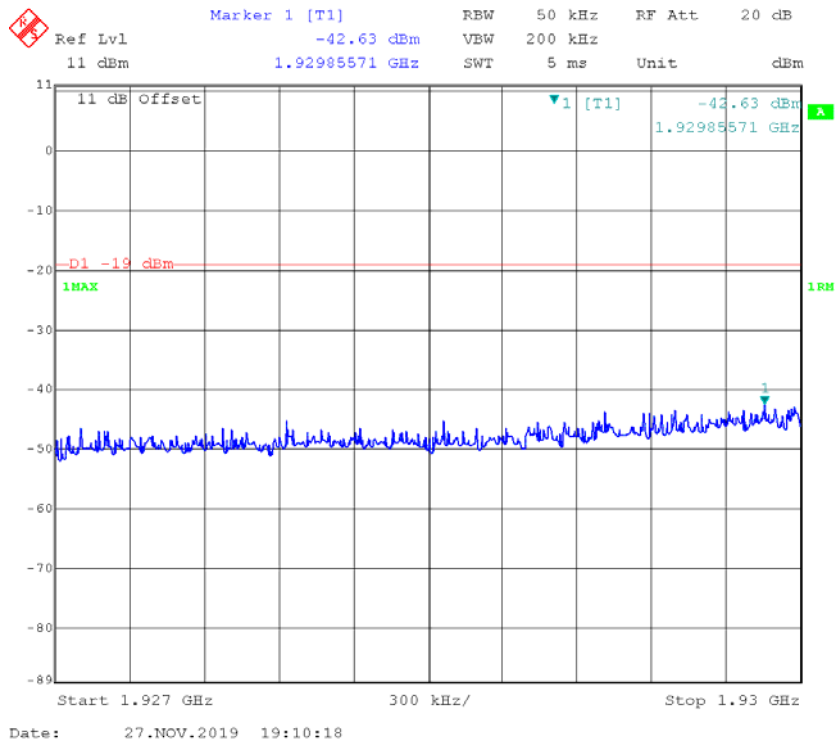

LTE Left Side Above AGC

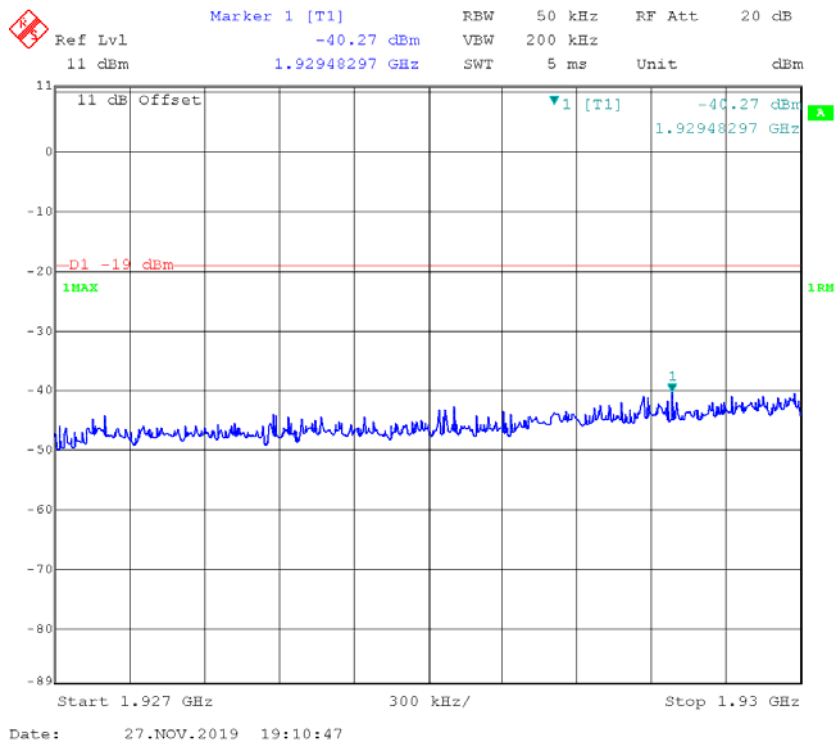

LTE Right Side Pre-AGC

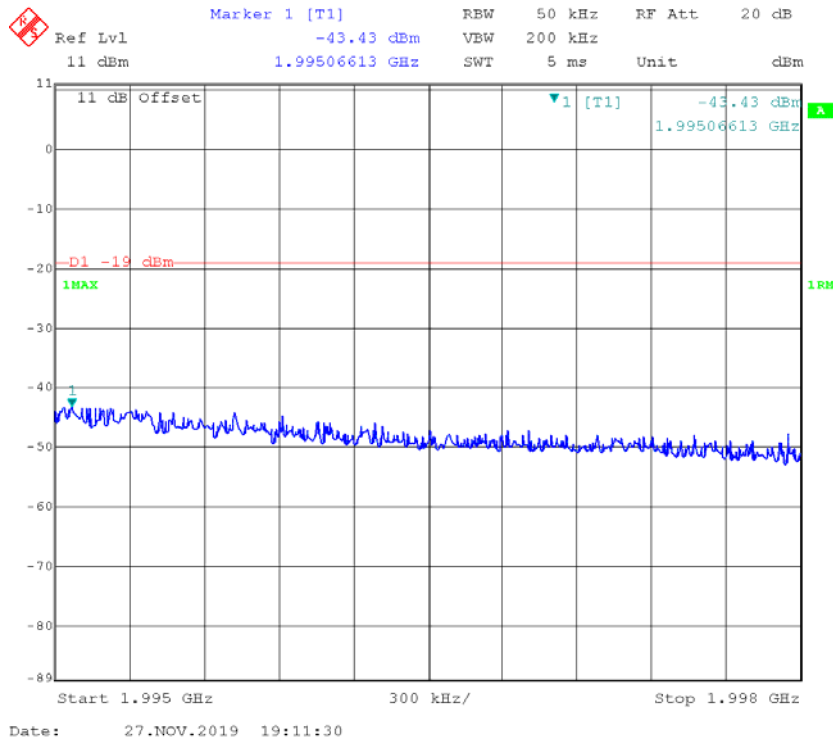

LTE Right Side Above AGC

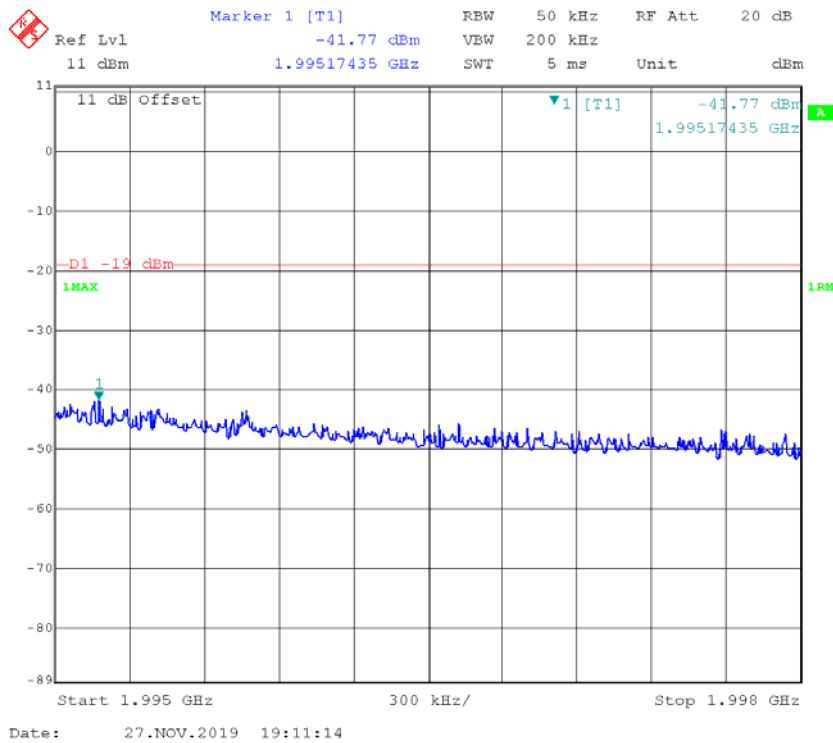

§ 20.21(e)(8)(i)(A), § 20.21(e)(8)(i)(H) & §20.21(e)(4) - NOISE LIMITS

Applicable Standards

According to § 20.21(e)(8)(i)(A) Noise Limits; § 20.21(e)(8)(i)(H) Transmit Power Off Mode (uplink and downlink noise power); §20.21(e)(4) Self-monitoring.

Test Procedure

Maximum transmitter noise power level

- a) Connect the EUT to the test equipment as shown in **Figure 3**. Begin with the uplink output connected to the spectrum analyzer. When measuring downlink noise, connect the downlink output to the spectrum analyzer.
- b) Set the spectrum analyzer RBW to 1 MHz with the VBW $\geq 3 \times$ RBW.
- c) Select the power averaging (RMS) detector and trace average over at least 100 traces.
- d) Set the center frequency of the spectrum analyzer to the center of the CMRS band under test with the span $\geq 2 \times$ the CMRS band.
- e) Measure the maximum transmitter noise power level.
- f) Save the spectrum analyzer plot as necessary for inclusion in the final test report.
- g) Repeat 7.7b) to 7.7f) for all operational uplink and downlink bands.
- h) Connect the EUT to the test equipment as shown in **Figure 4** for uplink. Affirm the coupled path of the RF coupler is connected to the spectrum analyzer.
- i) Configure the signal generator for 4.1 MHz AWGN operation.
- j) Set the spectrum analyzer RBW for 1 MHz with the VBW $\geq 3 \times$ RBW with a power averaging (rms) detector with at least 100 trace averages.
- k) Set the center frequency of the spectrum analyzer to the center of the CMRS band under test with the span $\geq 2 \times$ the CMRS band. This shall include all spectrum blocks in the particular CMRS band under test (see Annex A).
- l) For uplink noise measurements, set the spectrum analyzer center frequency for the uplink band under test and tune the signal generator to the center of the paired downlink band.
- m) Measure the maximum transmitter noise power level when varying the downlink signal generator output level from -90 dBm to -20 dBm, as measured at the input port, in 1 dB steps inside the RSSI-dependent region and in 10 dB steps outside the RSSI-dependent region. Report the six values closest to the limit with at least two points within the RSSI-dependent region of the limit. See noise limit in Annex D.
- n) Repeat 7.7.1h) through 7.7.1m) for all operational uplink.

Variable uplink noise timing

Variable uplink noise timing is to be measured as follows.

- a) Set the spectrum analyzer to the uplink frequency to be measured.
- b) Set the span to 0 Hz with a sweep time of 10 seconds.
- c) Set the power level of signal generator 1 to the lowest level of the RSSI-dependent noise.
- d) Select MAX HOLD and increase the power level of signal generator 1 by 10 dB for mobile boosters and 20 dB for fixed boosters.
- e) Confirm that the uplink noise decreases to the specified level within 1 second for mobile devices and 3 seconds for fixed devices
- f) Repeat 7.7.2a) to 7.7.2e) for all operational uplink bands.
- g) Include plots and summary table in test report.

Note: Some signal boosters will require a signal generator input because they will not operate unless a signal is received at the input terminals. If this is the case, connect a second signal generator and cycle the RF output to simulate this function.

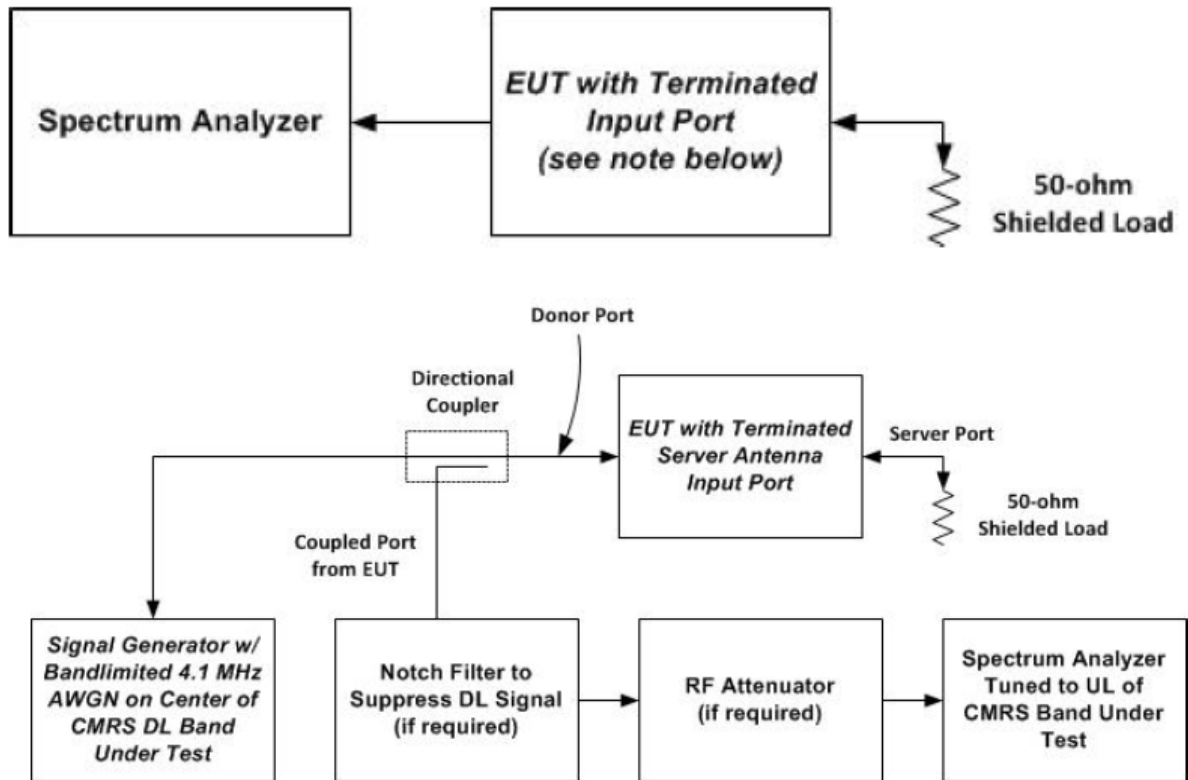

Test Data

Environmental Conditions

Temperature:	25.9~26.5°C
Relative Humidity:	42~49 %
ATM Pressure:	101.2 kPa

The testing was performed by Blake Yang from 2019-11-26 to 2019-11-27.

Test Result: Compliance. Please refer to following table.

Maximum Noise:

Mode	Operation Bands	Measured Value	Limit	Result
		dBm/MHz	dBm/MHz	
Uplink	Lower 700	-53.77	-45.51	Compliance
	Upper 700	-51.22	-44.64	Compliance
	Cellular	-50.96	-44.05	Compliance
	AWS	-54.34	-37.73	Compliance
	PCS	-51.98	-37.01	Compliance
Downlink	Lower 700	-48.60	-45.51	Compliance
	Upper 700	-49.63	-44.64	Compliance
	Cellular	-53.38	-44.05	Compliance
	AWS	-56.31	-37.73	Compliance
	PCS	-54.56	-37.01	Compliance

Note: Fixed booster maximum noise power shall not exceed $-102.5 \text{ dBm/MHz} + 20 \text{ Log}_{10}(\text{Frequency})$, where Frequency is the uplink mid-band frequency of the supported spectrum bands in MHz.

Uplink:

Lower 700MHz Band

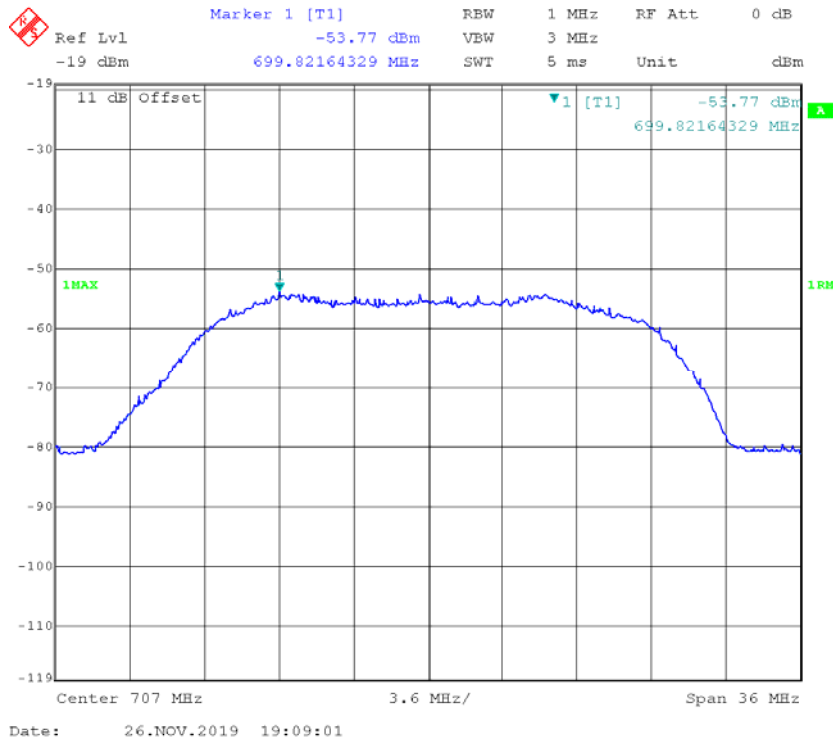

Upper 700MHz Band

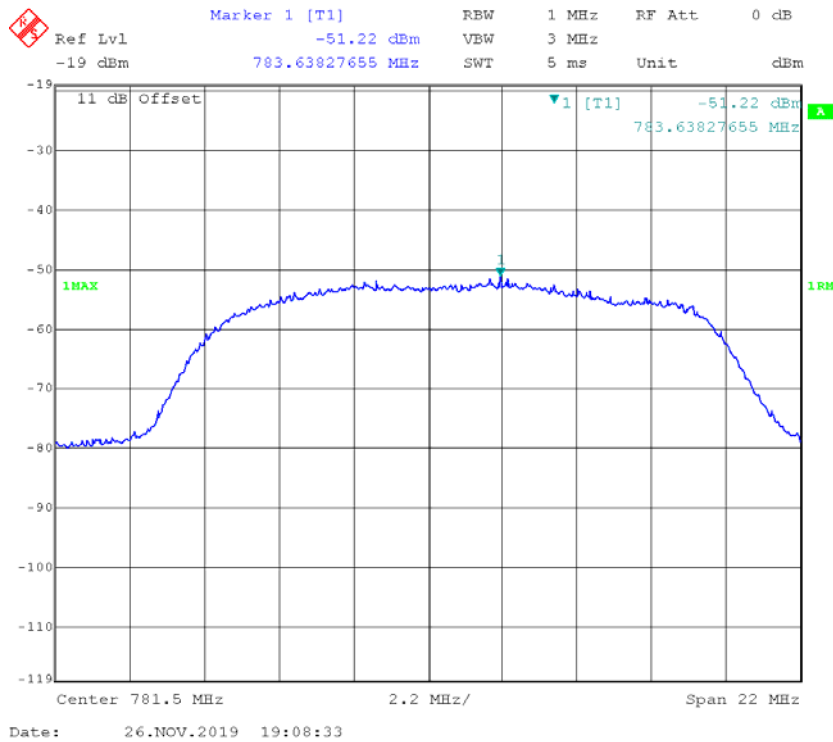

Cellular Band

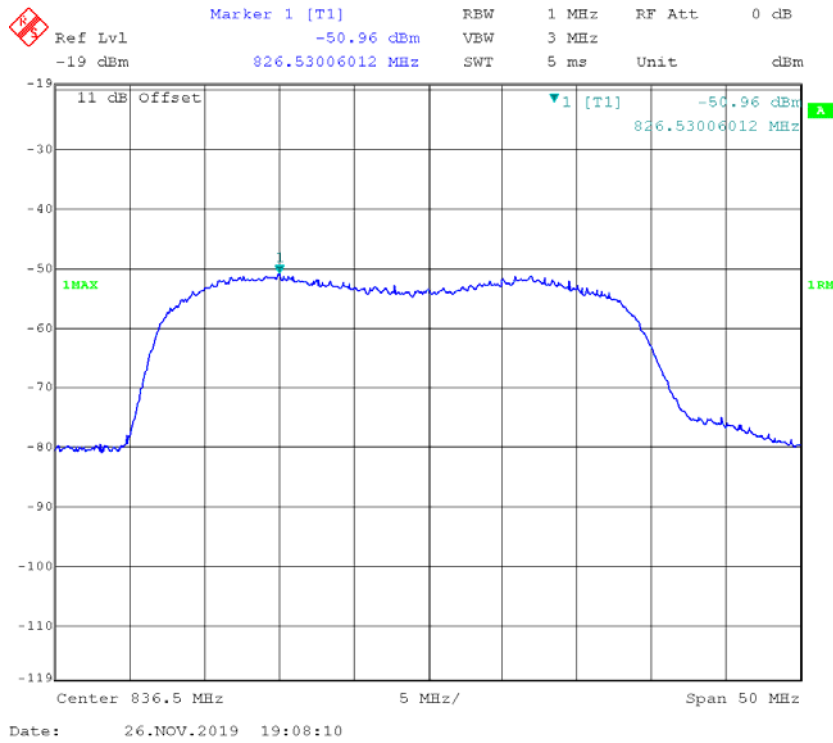

AWS Band



PCS Band

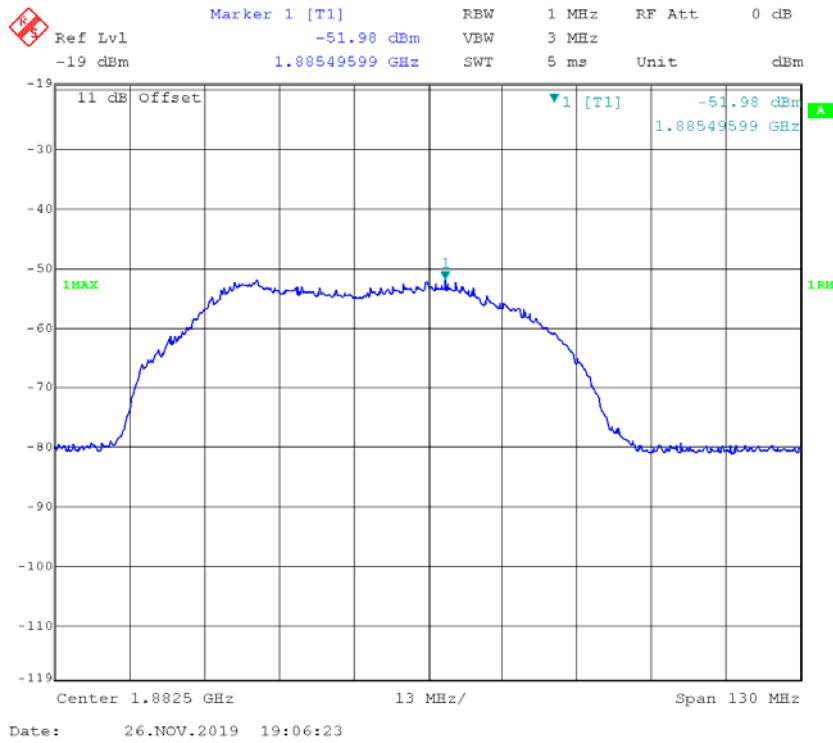

Downlink:

Lower 700MHz Band

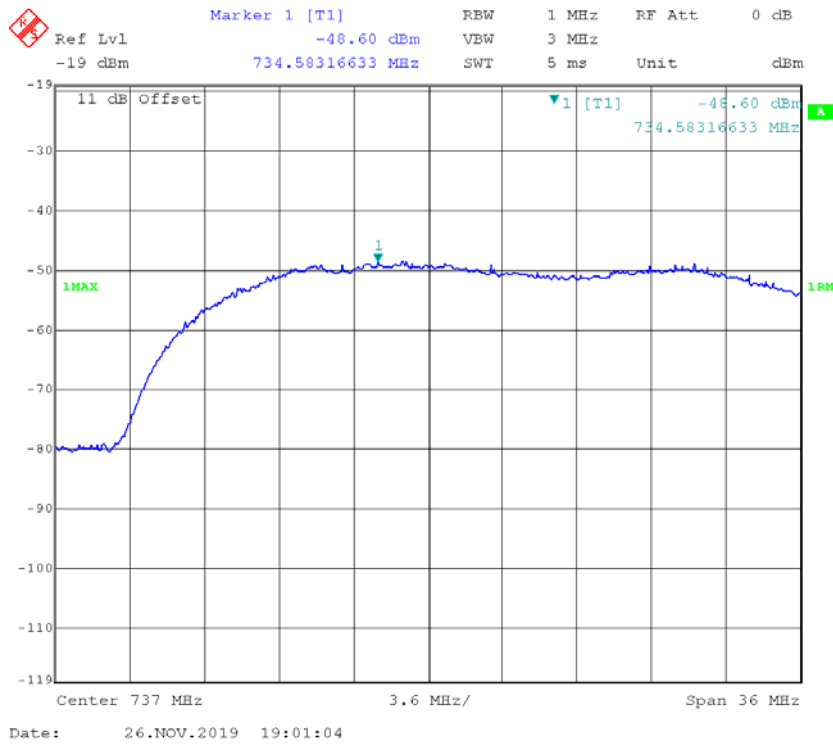

Upper 700MHz Band

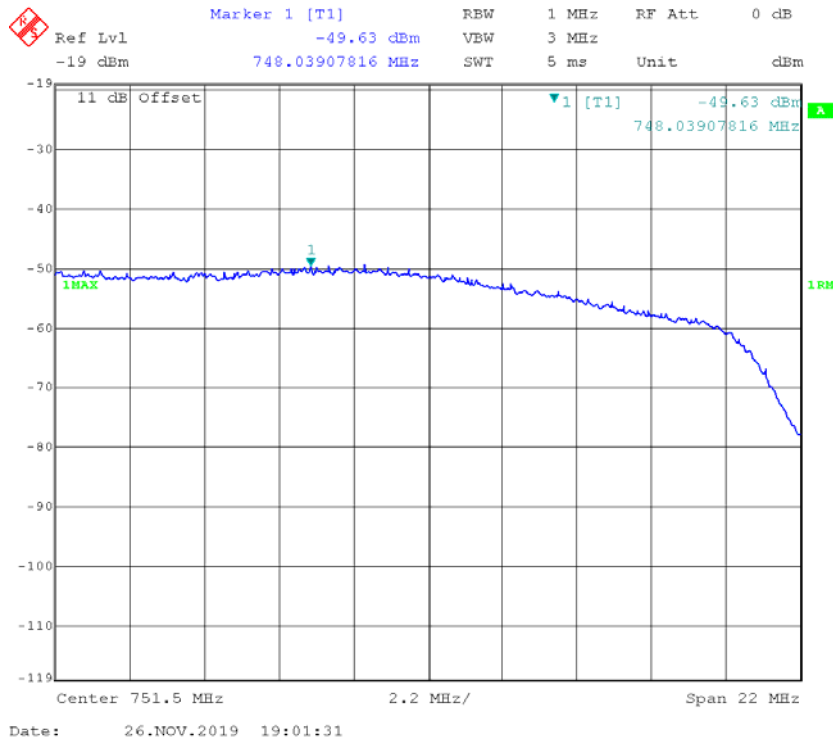

Cellular Band



AWS Band

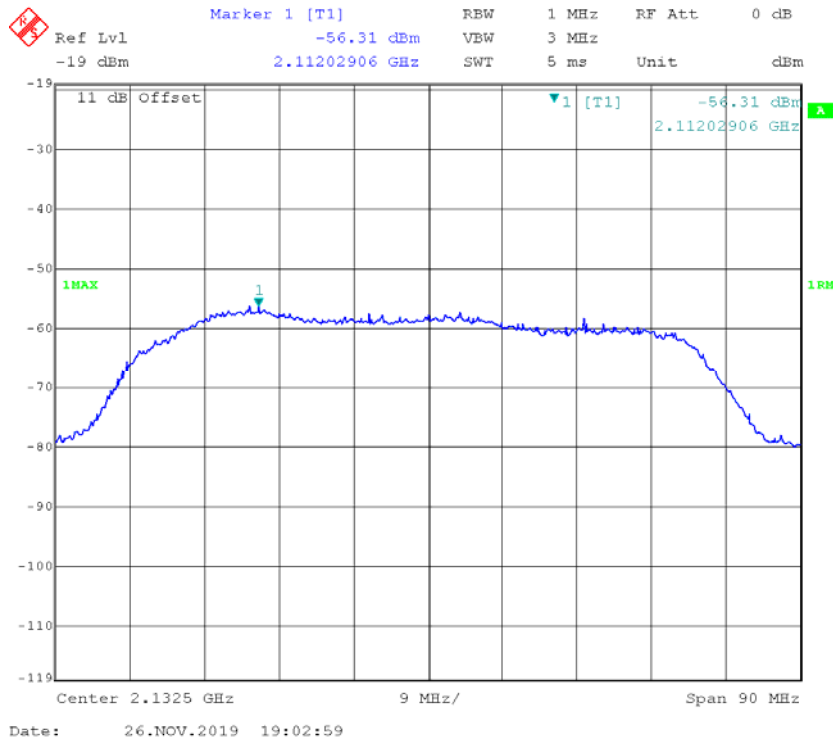

PCS Band

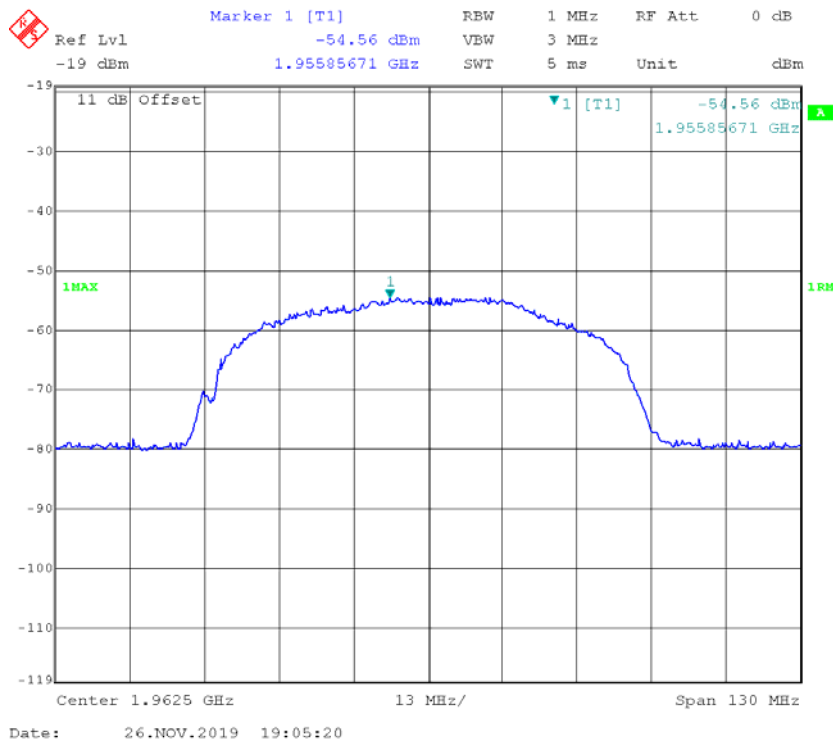

Variable uplink Noise limit test result:

Operation Bands	RSSI	Measured Value	Limit	Results
	dBm	dBm/MHz	dBm/MHz	
Lower 700	-80	-57.63	-45.51	Compliance
	-70	-58.32	-45.51	Compliance
	-60	-58.64	-45.51	Compliance
	-53	-59.87	-50.00	Compliance
	-52	-60.52	-51.00	Compliance
	-51	-61.54	-52.00	Compliance
Upper 700	-80	-55.94	-44.64	Compliance
	-70	-56.36	-44.64	Compliance
	-60	-57.32	-44.64	Compliance
	-52	-60.35	-51.00	Compliance
	-51	-61.25	-52.00	Compliance
	-50	-62.41	-53.00	Compliance
Cellular	-80	-54.94	-44.05	Compliance
	-70	-55.36	-44.05	Compliance
	-60	-56.87	-44.05	Compliance
	-54	-58.96	-49.00	Compliance
	-53	-60.14	-50.00	Compliance
	-52	-61.36	-51.00	Compliance
AWS	-80	-56.63	-37.73	Compliance
	-70	-57.25	-37.73	Compliance
	-60	-58.17	-37.73	Compliance
	-53	-60.36	-50.00	Compliance
	-52	-61.74	-51.00	Compliance
	-51	-62.44	-52.00	Compliance
PCS	-80	-55.47	-37.01	Compliance
	-70	-56.43	-37.01	Compliance
	-60	-57.18	-37.01	Compliance
	-52	-60.41	-51.00	Compliance
	-51	-62.36	-52.00	Compliance
	-50	-63.74	-53.00	Compliance

According to KDB 935210 D03 Signal Booster Measurements v04r03 Annex D, the Variable uplink Noise limit is -103 dBm – RSSI in RSSI-Dependent Region, out of RSSI-Dependent Region, it is -102.5 dBm/MHz + 20 Log10 (Frequency).

Variable Uplink Noise Timing:

Operating Band	Measured Value	Limit	Results
	s	s	
LOWER 700	0.34	3	Compliance
UPPER 700	0.18	3	Compliance
Cellular	0.22	3	Compliance
AWS	0.26	3	Compliance
PCS	0.32	3	Compliance

Note: The uplink noise decreases to the specified level within 1 second for mobile devices and 3 seconds for fixed devices.

Lower 700MHz Band

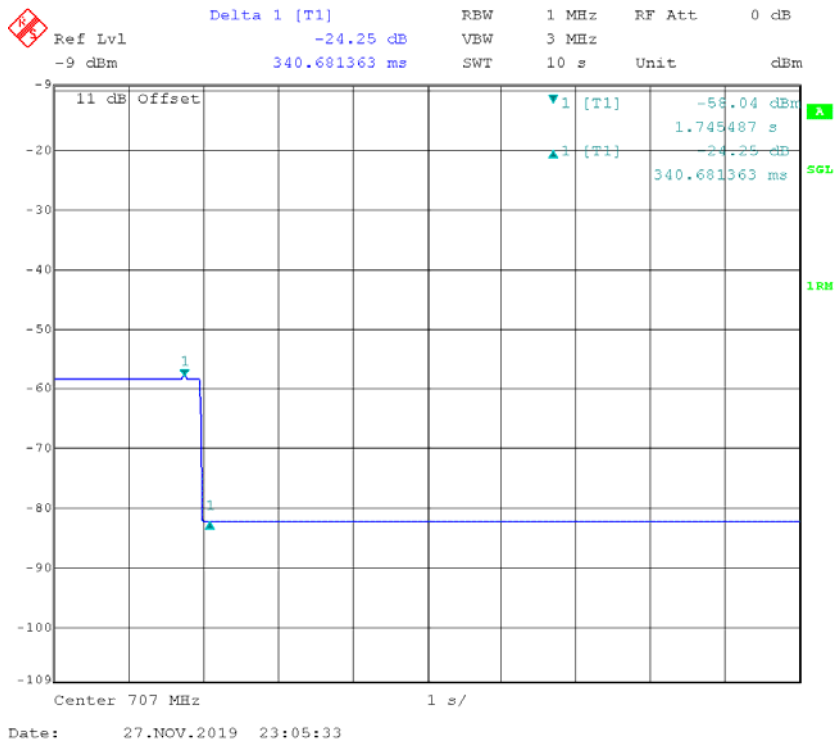

Upper 700MHz Band

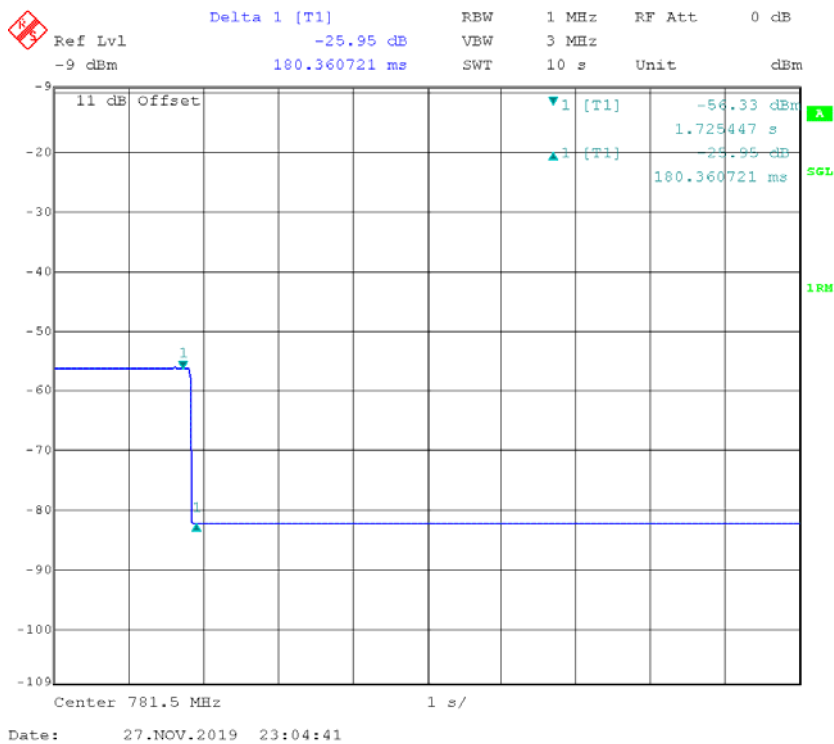

Cellular Band

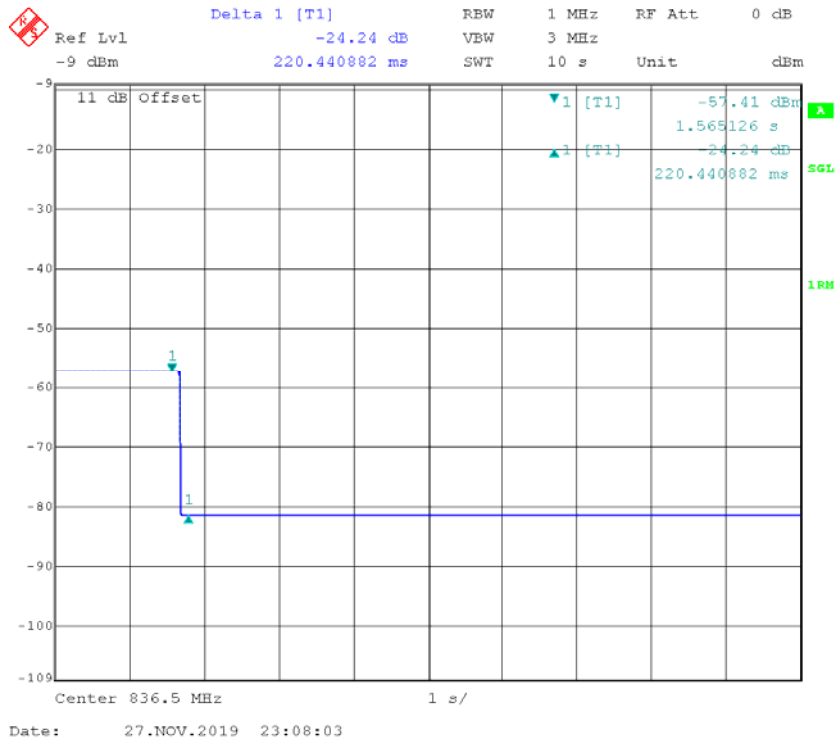

AWS Band

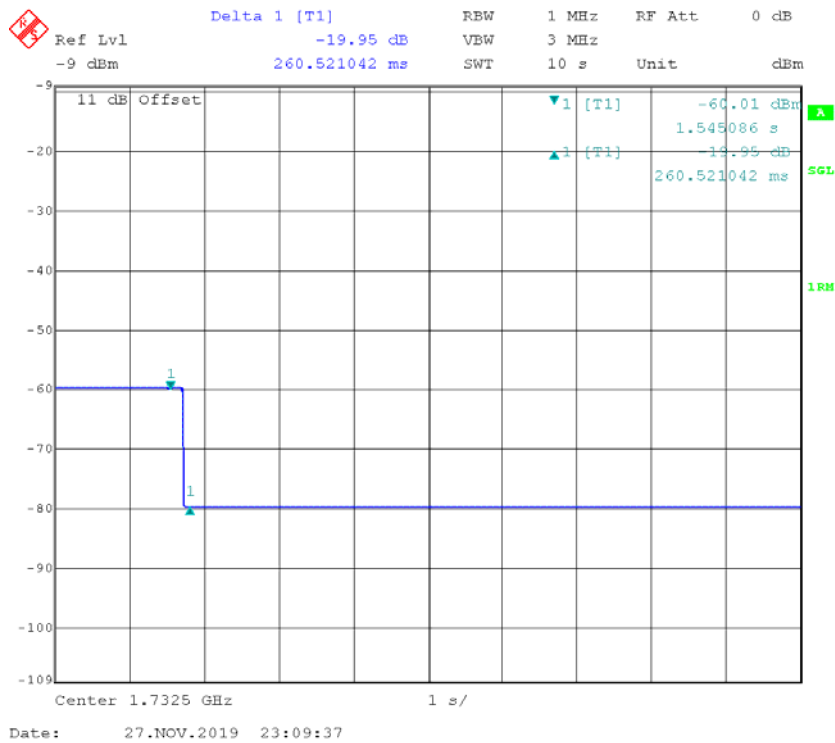

PCS Band

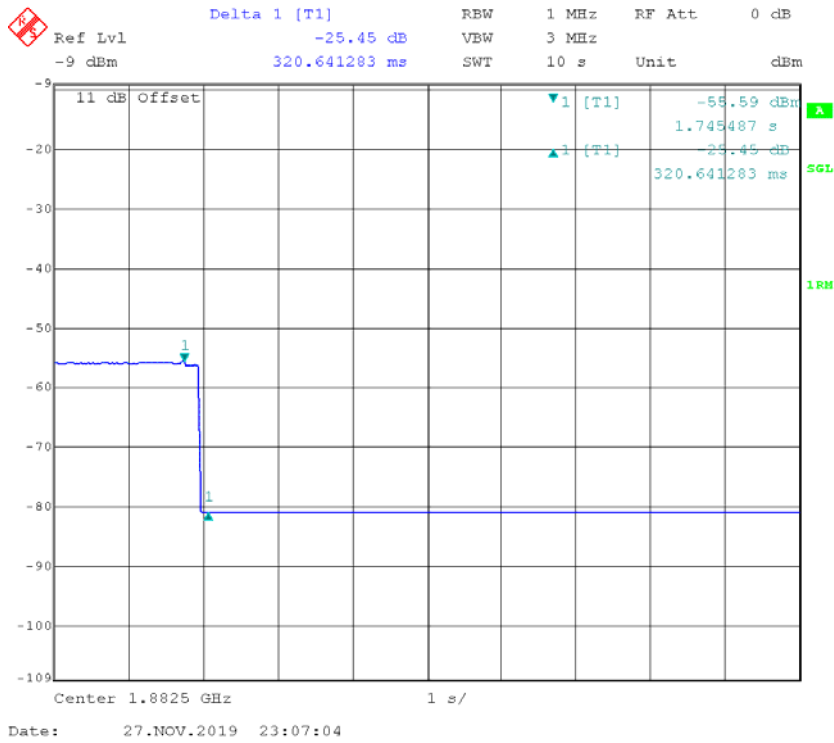

§ 20.21(e)(8)(i)(I) & §20.21(e)(4) - UPLINK INACTIVITY

Applicable Standards

According to § 20.21(e)(8)(i)(I) Uplink Inactivity & §20.21(e)(4); §20.21(e)(4) Self-monitoring.

Test Procedure

This measurement procedure is intended to demonstrate compliance to the uplink inactivity requirements specified for wideband consumer signal boosters in § 20.21(e)(8)(i)(I).

- a) Connect the EUT to the test equipment as shown in **Figure 3** with the uplink output connected to the spectrum analyzer.
- b) Select the RMS power averaging detector.
- c) Set the spectrum analyzer RBW for 1 MHz with the $VBW \geq 3 \times RBW$.
- d) Set the center frequency of the spectrum analyzer to the center of the uplink operational band.
- e) Set the span for 0 Hz with a single sweep time for a minimum of 700 seconds.
- f) Start to capture a new trace using MAX HOLD.
- g) After approximately 15 seconds turn on the EUT power.
- h) Once the full spectrum analyzer trace is complete place a MARKER on the leading edge of the pulse and use the DELTA MARKER METHOD to measure the time until the uplink becomes inactive.
- i) Affirm that the noise level for the squelched signal is below the uplink inactivity noise power limit, as specified by the rules.
- j) Capture the plot for inclusion in the test report.
- k) Measure noise using procedures in 7.7.1a) to 7.7.1f).
- l) Repeat 7.8d) through 7.8k) for all operational uplink bands.

Note: Some signal boosters will require a signal generator input because they will not operate unless a signal is received at the input terminals. If this is the case, connect a signal generator and cycle the RF output to simulate this function.

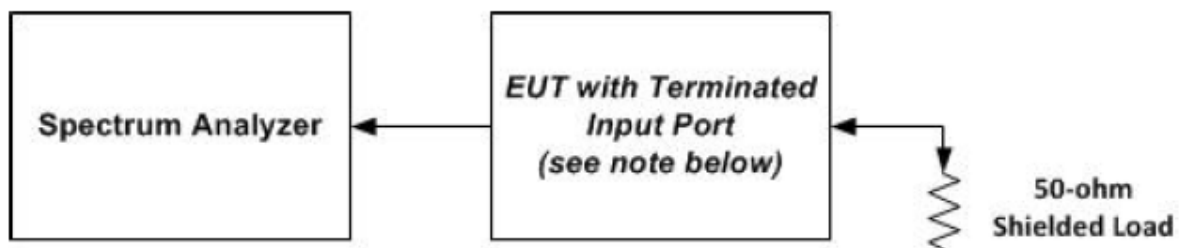

Test Data

Environmental Conditions

Temperature:	25.9~26.5 °C
Relative Humidity:	42~49 %
ATM Pressure:	101.2 kPa

The testing was performed by Blake Yang on 2019-11-26 and 2019-11-27.

Test Result: Compliance. Please refer to following table.

Operation Band	Measured value	Limit	Result
	s	s	
LOWER 700	297.39	300	Compliance
UPPER 700	297.39		Compliance
Cellular	295.99		Compliance
AWS	297.39		Compliance
PCS	295.99		Compliance

Note: When the consumer booster is not serving an active device connection after 5 minutes the uplink noise power not exceed -70 dBm/MHz.

Lower 700MHz Band

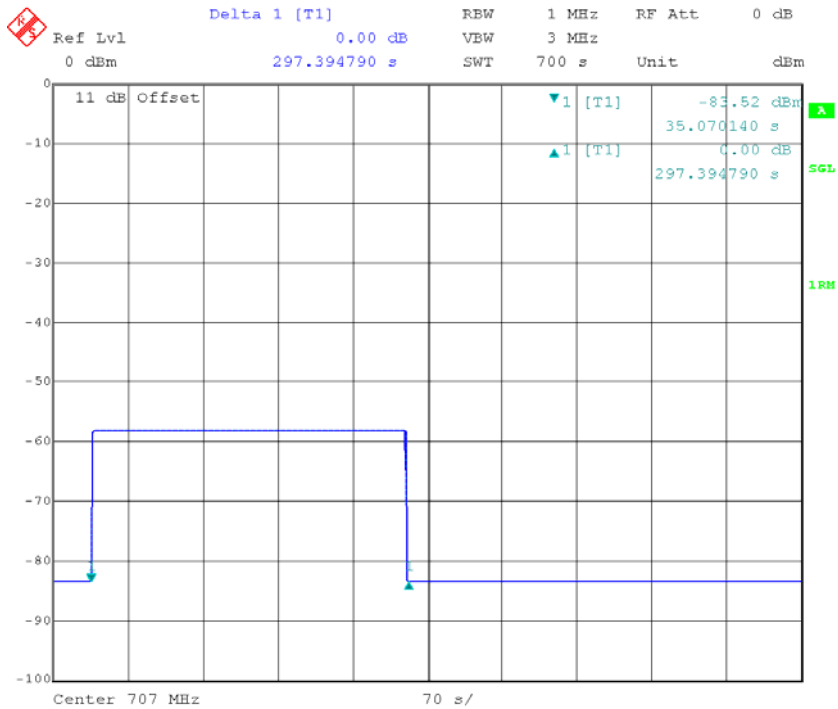

Date: 26.NOV.2019 23:33:31

Upper 700MHz Band

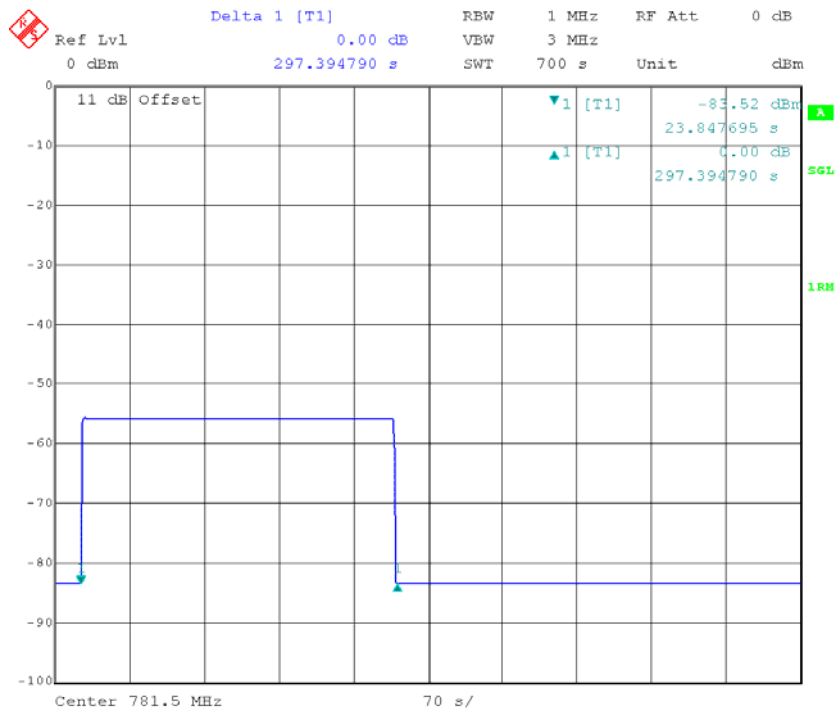

Date: 26.NOV.2019 23:45:55

Cellular Band

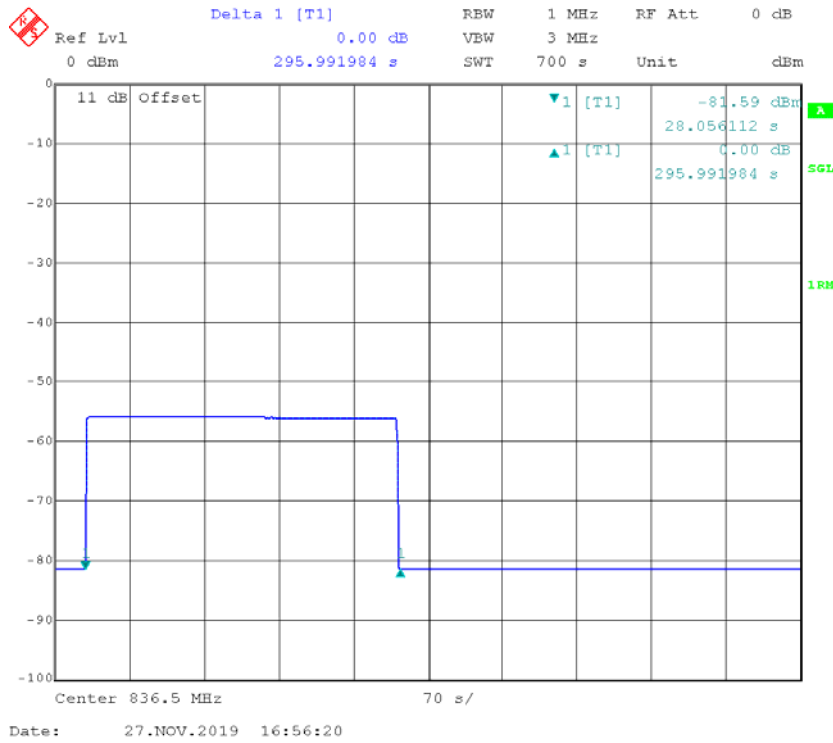

AWS Band

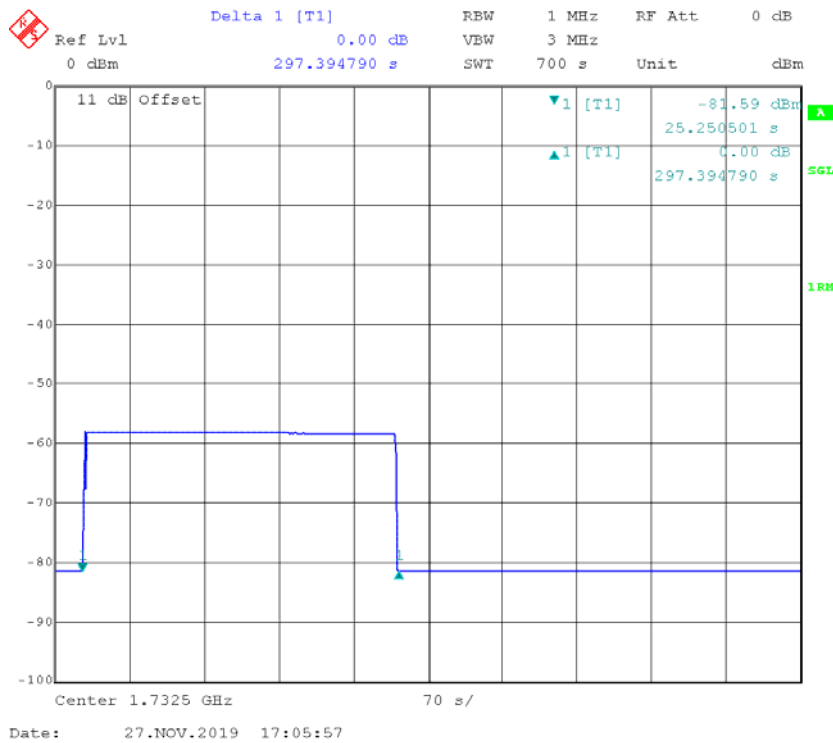

PCS Band

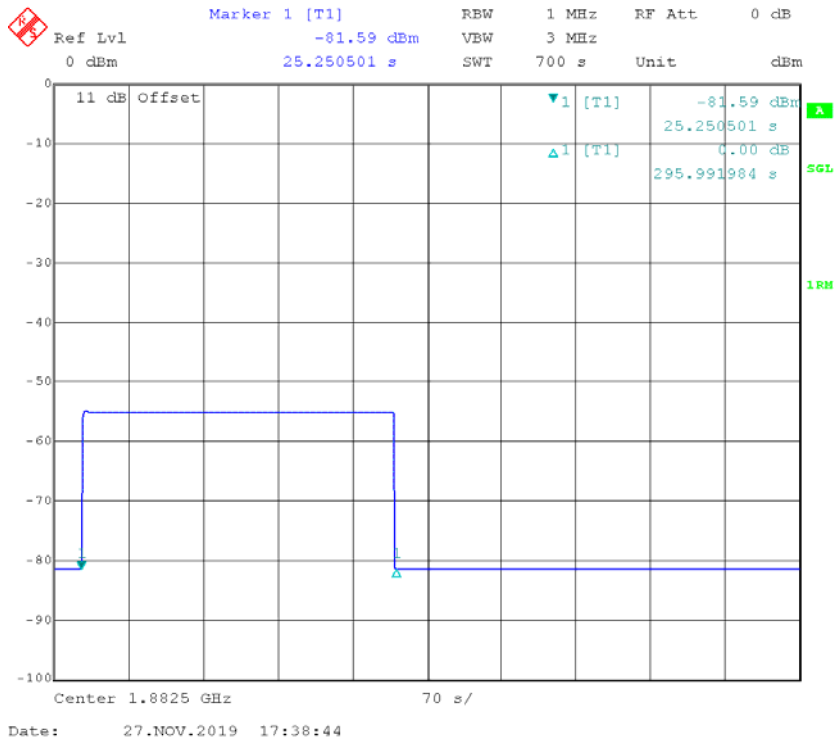

§ 20.21(e)(8)(i)(C)(1) & § 20.21(e)(8)(i)(H) - VARIABLE BOOSTER GAIN

Applicable Standards

Rule paragraph(s): § 20.21(e)(8)(i)(C)(1) *Booster Gain Limits* (variable gain); § 20.21(e)(8)(i)(H) *Transmit Power Off Mode* (uplink gain).

Test Procedure

Maximum gain

This procedure shall be used to demonstrate compliance to the booster gain limits specified for wideband consumer signal boosters in § 20.21(e)(8)(i)(C) or § 20.21(e)(8)(i)(H). The variable booster gain limits are expressed as a function of RSSI and MSCL. The RSSI is varied over a range of values as specified within the procedure. Refer to Annex B of this document for guidance on determining the applicable MSCL value.

- a) Connect the EUT to the test equipment as shown in **Figure 5** with the uplink output connected to signal generator 1. Confirm that the coupled path of the RF coupler is connected to the spectrum analyzer.
- b) Configure downlink signal generator 1 for AWGN operation with a 99% occupied bandwidth of 4.1 MHz tuned to the center of the operational band.
- c) Set the power level and frequency of signal generator 2 to a value 5 dB below the AGC level determined from 7.2. The signal type is AWGN with a 99% OBW of 4.1 MHz.
- d) Set RBW = 100 kHz.
- e) Set VBW \geq 300 kHz.
- f) Select the CHANNEL POWER measurement mode.
- g) Select the RMS (power averaging) detector.
- h) Ensure that the number of measurement points per sweep $\geq (2 \times \text{span})/\text{RBW}$.
- i) Sweep time = auto couple or as necessary (but no less than auto couple value).
- j) Trace average at least 10 traces in power averaging (i.e., RMS) mode.
- k) Measure the maximum channel power and compute maximum gain when varying the signal generator 1 output to a level from -90 dBm to -20 dBm as measured at the input port in 1 dB steps inside the RSSI-dependent region and 10 dB steps outside the RSSI-dependent region and report the six values closest to the limit, including at least two points from within the RSSI-dependent region of operation. See gain limit in charts in Annex D for uplink gain requirements. Additionally, document that the EUT provides equivalent uplink and downlink gain, and when operating in shutoff mode the uplink and downlink gain is within the transmit power off mode gain limits.
- l) Repeat 7.9.1b) to 7.9.1k) for all operational uplink bands.

Variable uplink gain timing

Variable uplink gain timing is to be measured as follows.

- a) Set the spectrum analyzer to the uplink frequency to be measured.
- b) Set the span to 0 Hz with a sweep time of 10 seconds.
- c) Set the power level of signal generator 1 to the lowest level of the RSSI-dependent gain.
- d) Select MAX HOLD and increase the power level of signal generator 1 by 10 dB for mobile boosters and 20 dB for fixed indoor boosters. Signal generator 2 remains same, as described in 7.9.1c).
- e) Confirm that the uplink gain decreases to the specified levels within 1 second for mobile devices and 3 seconds for fixed devices.
- f) Repeat 7.9.2a) to 7.9.2e) for all operational uplink bands.

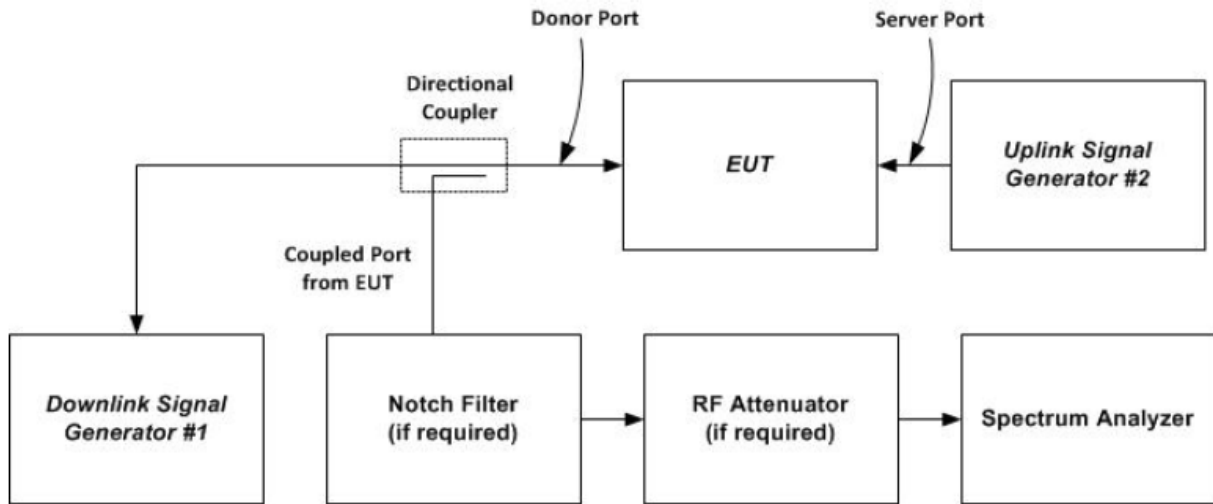

Figure 5 – Variable gain instrumentation test setup

Test Data

Environmental Conditions

Temperature:	25.2 °C
Relative Humidity:	40 %
ATM Pressure:	102.5 kPa

The testing was performed by Blake Yang on 2019-11-29.

Test Result: Compliance. Please refer to following table.

MSCL calculation:

Omni Antenna:

Operation Bands	Frequency	Distance	Path Loss	Indoor Antenna Gain	Indoor Cable Loss	Polarity Loss	MSCL
	MHz						
Lower 700MHz	707	1.5	33.01	3	0.8	3.01	33.82
Upper 700MHz	781.5	1.5	33.88	3	0.8	3.01	34.69
Cellular	836.5	1.5	34.47	3	0.8	3.01	35.28
AWS	1732.5	1.5	40.80	3	1.4	3.01	42.21
PCS	1882.5	1.5	41.52	3	1.4	3.01	42.93

Note:

Path loss=20logf+20logd-27.5

Polarity loss=20log(1/sin(45))=3.01

d=1.5m, please refer to the user manual

Panel Antenna:

Operation Bands	Frequency	Distance	Path Loss	Indoor Antenna Gain	Indoor Cable Loss	Polarity Loss	MSCL
	MHz	m	dB	(dBi)	(dB)	(dB)	
Lower 700MHz	707	1	29.49	7	0.8	3.01	26.30
Upper 700MHz	781.5	1	30.36	7	0.8	3.01	27.17
Cellular	836.5	1	30.95	7	0.8	3.01	27.76
AWS	1732.5	1	37.27	9	1.4	3.01	32.68
PCS	1882.5	1	37.99	9	1.4	3.01	33.40

Note:

Path loss=20logf+20logd-27.5

Polarity loss=20log(1/sin(45))=3.01

d=1m, please refer to the user manual

Variable booster gain:

Operation Bands	RSSI	P _{in}	P _{out}	MSCL	Measured Value	Limit	Result
	dBm	dBm	dBm	dB	dB	dB	
LOWER 700	-70	-38.73	8.45	26.3	47.18	62.30	Compliance
	-60	-38.73	6.14	26.3	44.87	52.30	Compliance
	-50	-38.73	1.46	26.3	40.19	42.30	Compliance
	-43	-38.73	-5.21	26.3	33.52	35.30	Compliance
	-42	-38.73	-6.56	26.3	32.17	34.30	Compliance
	-41	-38.73	-7.65	26.3	31.08	33.30	Compliance
UPPER 700	-70	-37.52	9.51	27.17	47.03	63.17	Compliance
	-60	-37.52	8.63	27.17	46.15	53.17	Compliance
	-50	-37.52	3.04	27.17	40.56	43.17	Compliance
	-45	-37.52	-1.53	27.17	35.99	38.17	Compliance
	-44	-37.52	-2.41	27.17	35.11	37.17	Compliance
	-43	-37.52	-3.25	27.17	34.27	36.17	Compliance
Cellular	-70	-37.86	7.53	27.76	45.39	63.76	Compliance
	-60	-37.86	6.42	27.76	44.28	53.76	Compliance
	-50	-37.86	3.43	27.76	41.29	43.76	Compliance
	-47	-37.86	-0.52	27.76	37.34	40.76	Compliance
	-46	-37.86	-1.45	27.76	36.41	39.76	Compliance
	-45	-37.86	-2.58	27.76	35.28	38.76	Compliance
AWS	-70	-40.47	9.43	32.68	49.90	68.68	Compliance
	-60	-40.47	8.52	32.68	48.99	58.68	Compliance
	-50	-40.47	4.64	32.68	45.11	48.68	Compliance
	-40	-40.47	-1.56	32.68	36.91	38.68	Compliance
	-39	-40.47	-2.43	32.68	37.04	37.68	Compliance
	-38	-40.47	-3.81	32.68	36.66	36.68	Compliance
PCS	-70	-40.25	8.94	33.4	49.19	69.40	Compliance
	-60	-40.25	7.52	33.4	47.77	59.40	Compliance
	-50	-40.25	6.53	33.4	46.78	49.40	Compliance
	-41	-40.25	-0.58	33.4	39.67	40.40	Compliance
	-40	-40.25	-1.63	33.4	38.62	39.40	Compliance
	-39	-40.25	-2.78	33.4	37.47	38.40	Compliance

Note: Variable booster gain Limit: -34 dB-RSSI + MSCL.

The minimum MSCL was used for limit calculation.

Variable gain timing:

Operation Bands	Measured value	Limit	Results
MHz	s	s	
LOWER 700	0.24	3	Compliance
UPPER 700	0.18		Compliance
Cellular	0.22		Compliance
AWS	0.28		Compliance
PCS	0.24		Compliance

Lower 700MHz Band

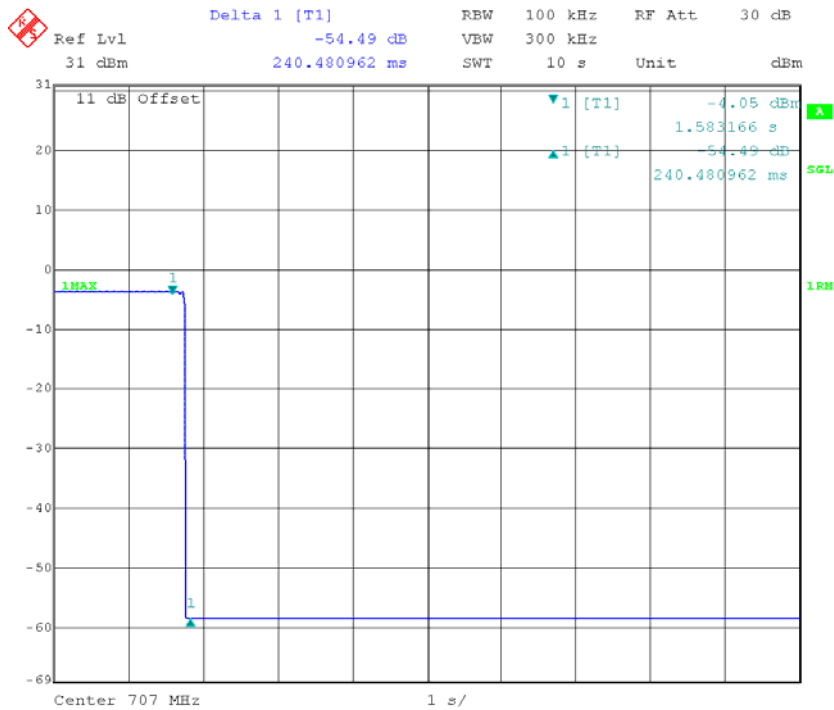

Upper 700MHz Band

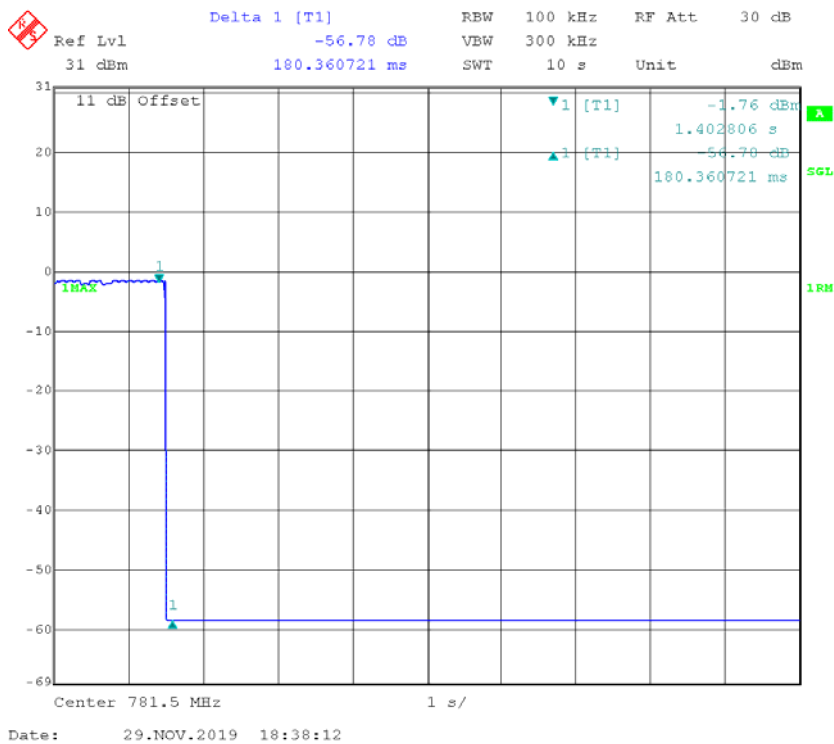

Cellular Band

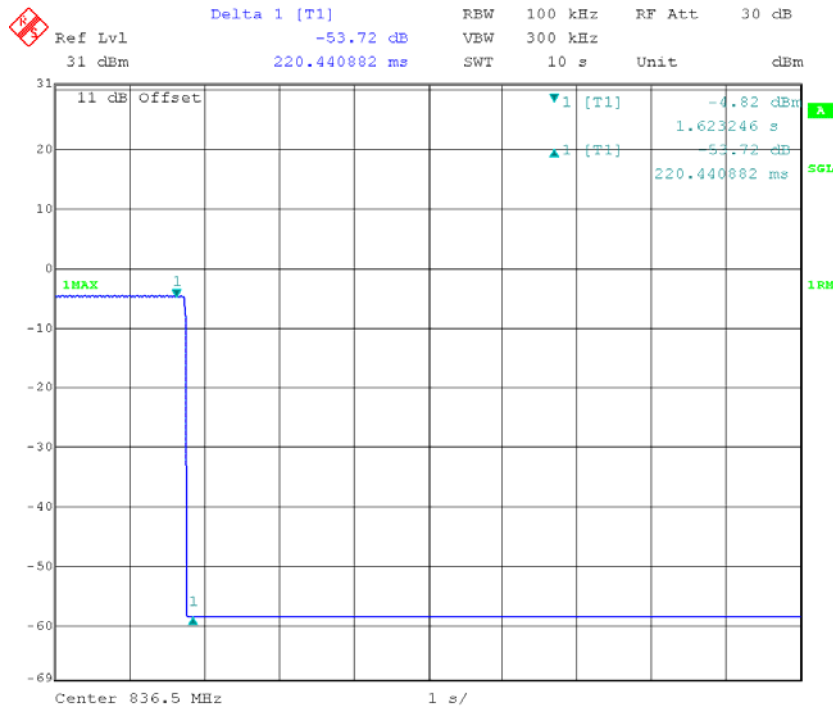

Date: 29.NOV.2019 18:44:41

AWS Band



Date: 29.NOV.2019 18:46:38

PCS Band

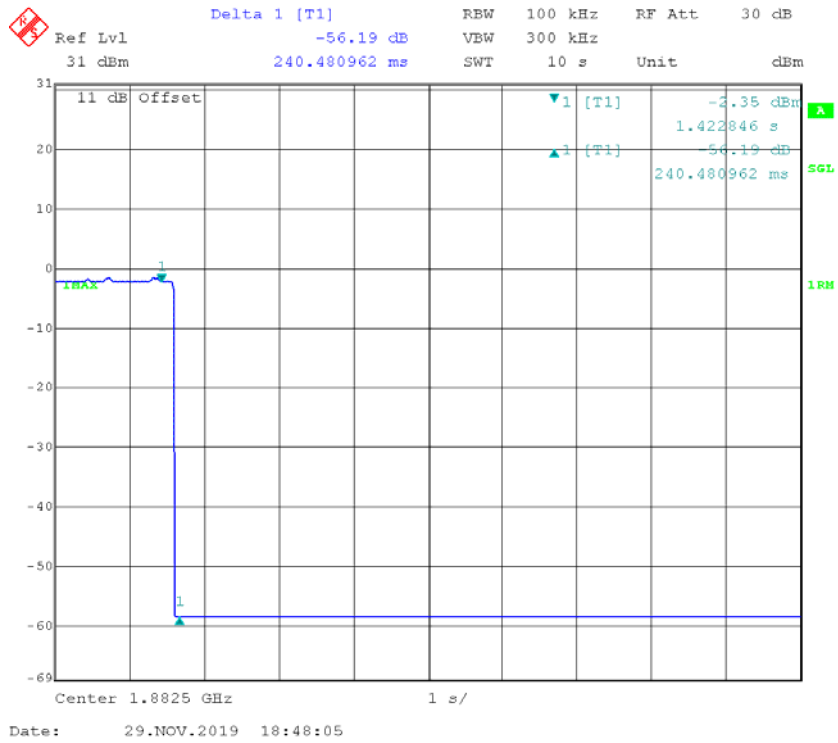

§ 2.1049 - OCCUPIED BANDWIDTH

Applicable Standards

According to § 2.1049 Measurements required: Occupied bandwidth.

Test Procedure

This measurement is required to compare the uniformity of the output signal relative to the input signal and to satisfy the requirements of § 2.1049.

- a) Connect the test equipment as shown in **Figure 6** to measure the characteristics of the test signals produced by the signal generator.
- b) Set VBW to $\geq 3 \times \text{RBW}$.
- c) Set the center frequency of the spectrum analyzer to the center of the operational band. The span will be adjusted for each modulation type and occupied bandwidth as necessary for accurately viewing the signals.
- d) Set the signal generator for power level to match the values obtained in 7.2.
- e) Set the signal generator modulation type for GSM with a PRBS pattern and allow the trace on the signal generator to stabilize adjusting the span as necessary.
- f) Set the spectrum analyzer RBW for 1% to 5% of the emissions bandwidth.
- g) Capture the spectrum analyzer trace for inclusion in the test report.
- h) Repeat 7.10c) to 7.10g) for CDMA and W-CDMA modulation adjusting the span as necessary for all uplink and downlink operational bands. AWGN or LTE may be used in place of W-CDMA, as an option.
- i) Connect the test equipment as shown in **Figure 1**. Begin with the uplink output connected to the spectrum analyzer.
- j) Repeat 7.10c) to 7.10h) in this new configuration.

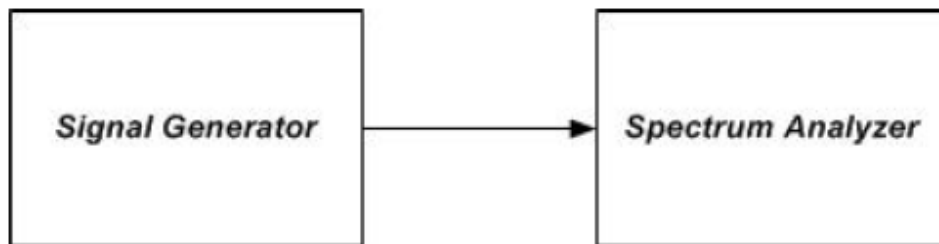

Figure 6 – Occupied bandwidth instrumentation test setup

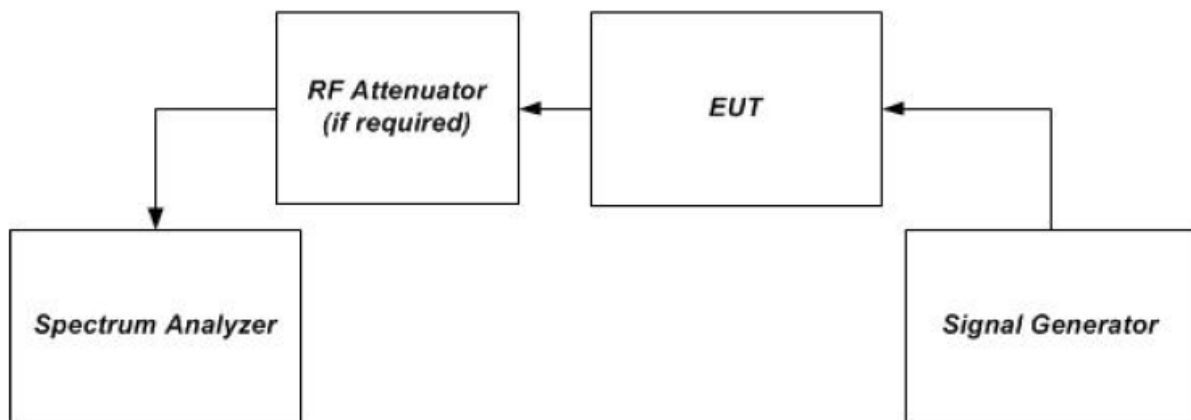

Figure 1 – Band verification test instrumentation setup

Test Data

Environmental Conditions

Temperature:	26.5 °C
Relative Humidity:	49 %
ATM Pressure:	101.2 kPa

The testing was performed by Blake Yang on 2019-11-26.

Test Result: Compliance. Please refer to following table.

Input-versus-output signal comparison

Mode	Operation Band	Signal type	Input	Output	Results
			MHz	MHz	
Uplink	Lower 700	CDMA	1.281	1.275	Compliance
		GSM	0.244	0.246	Compliance
		WCDMA	4.188	4.168	Compliance
	Upper 700	CDMA	1.275	1.289	Compliance
		GSM	0.244	0.244	Compliance
		WCDMA	4.188	4.228	Compliance
	Cellular	CDMA	1.281	1.281	Compliance
		GSM	0.244	0.246	Compliance
		WCDMA	4.148	4.188	Compliance
	AWS	CDMA	1.281	1.281	Compliance
		GSM	0.244	0.246	Compliance
		WCDMA	4.188	4.188	Compliance
	PCS	CDMA	1.281	1.281	Compliance
		GSM	0.244	0.246	Compliance
		WCDMA	4.188	4.188	Compliance
Downlink	Lower 700	CDMA	1.275	1.281	Compliance
		GSM	0.244	0.246	Compliance
		WCDMA	4.208	4.168	Compliance
	Upper 700	CDMA	1.281	1.281	Compliance
		GSM	0.244	0.244	Compliance
		WCDMA	4.208	4.188	Compliance
	Cellular	CDMA	1.287	1.281	Compliance
		GSM	0.248	0.246	Compliance
		WCDMA	4.188	4.188	Compliance
	AWS	CDMA	1.281	1.281	Compliance
		GSM	0.244	0.244	Compliance
		WCDMA	4.228	4.188	Compliance
	PCS	CDMA	1.287	1.275	Compliance
		GSM	0.248	0.244	Compliance
		WCDMA	4.188	4.208	Compliance

**Uplink:
Lower 700 Band:**

GSM Input

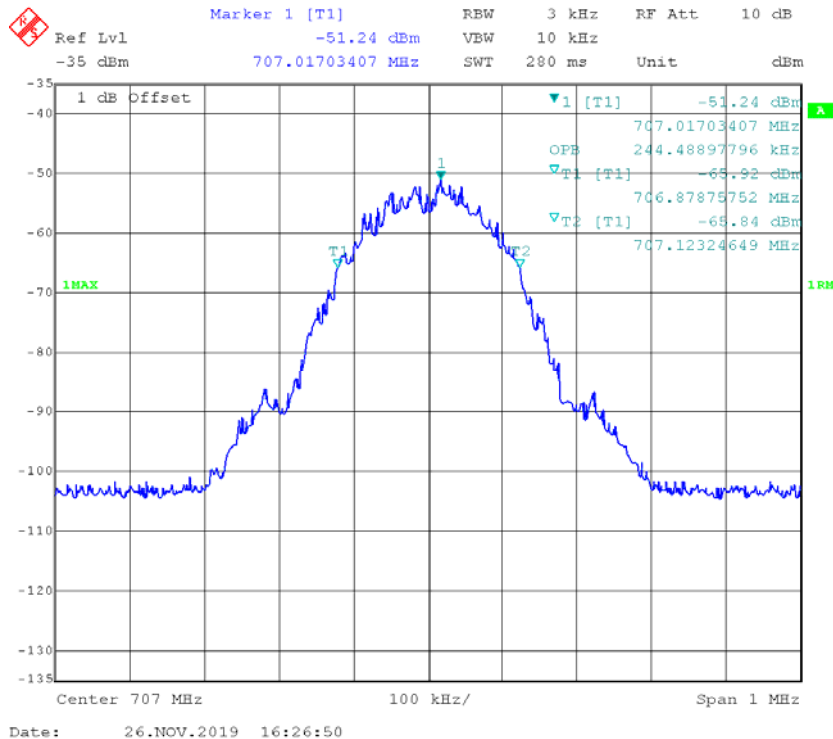

GSM Output

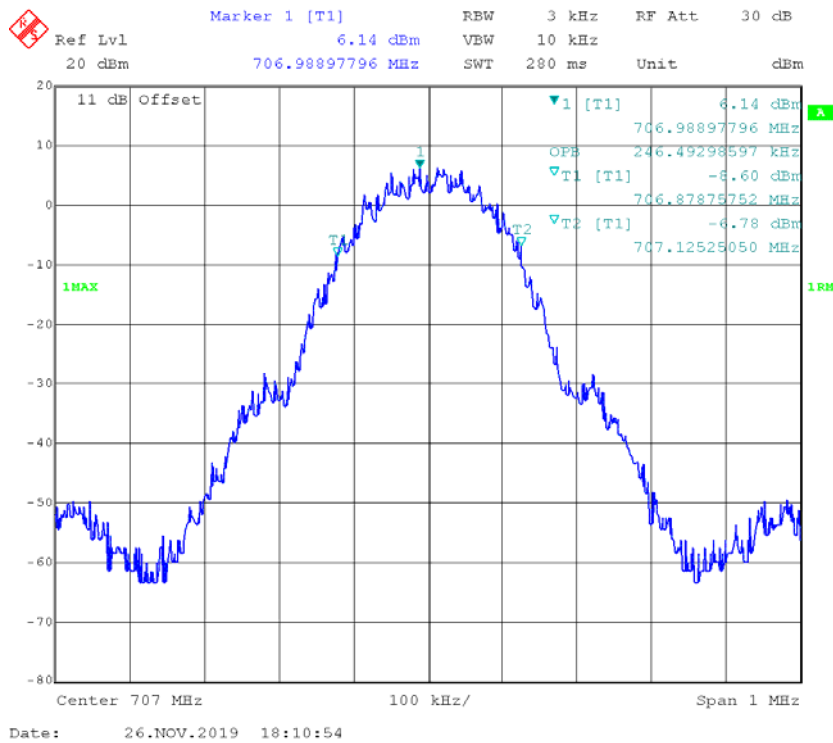

CDMA Input

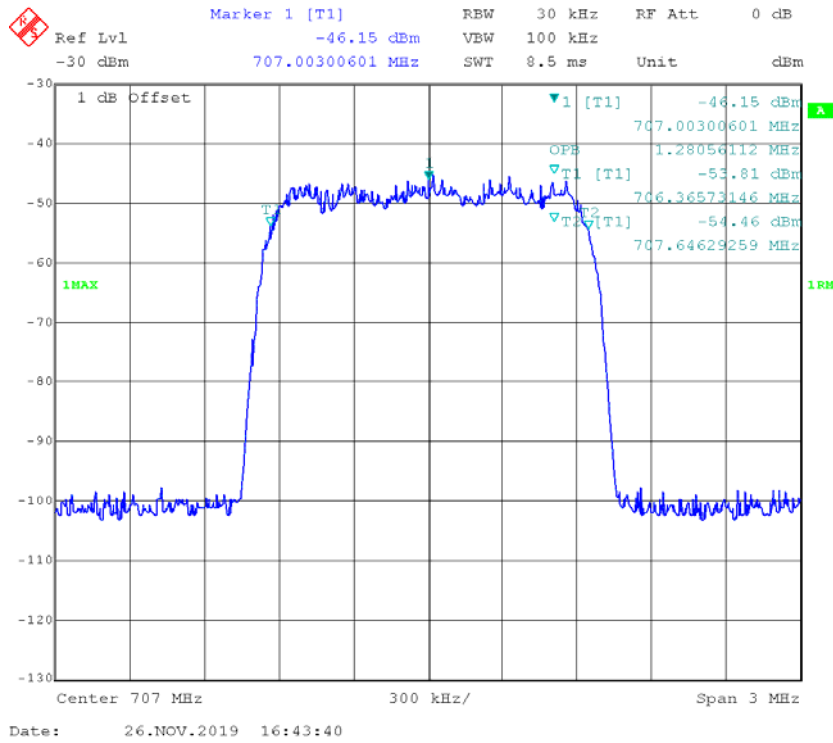

CDMA Output

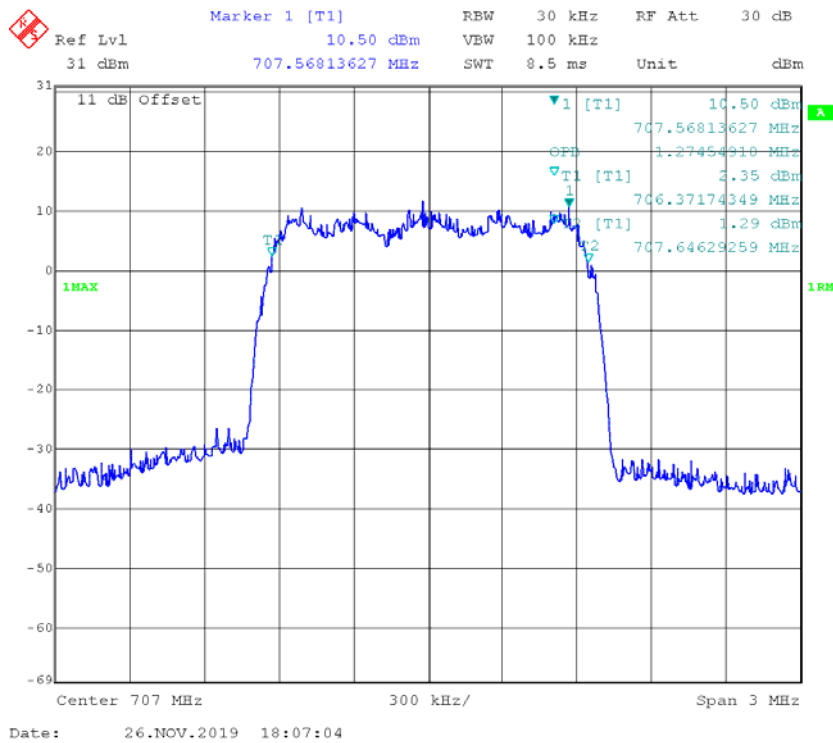

WCDMA Input

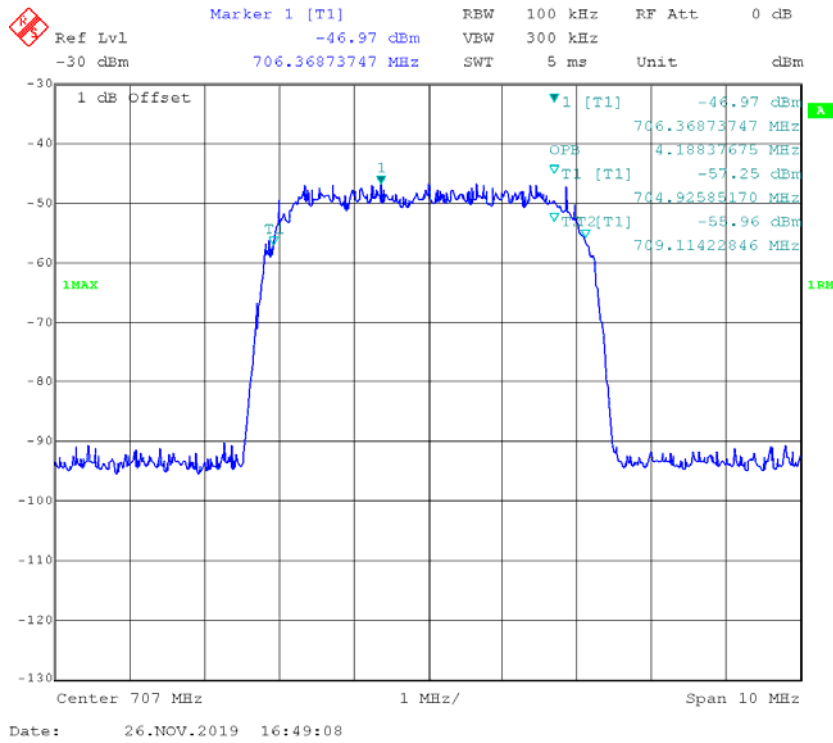

WCDMA Output

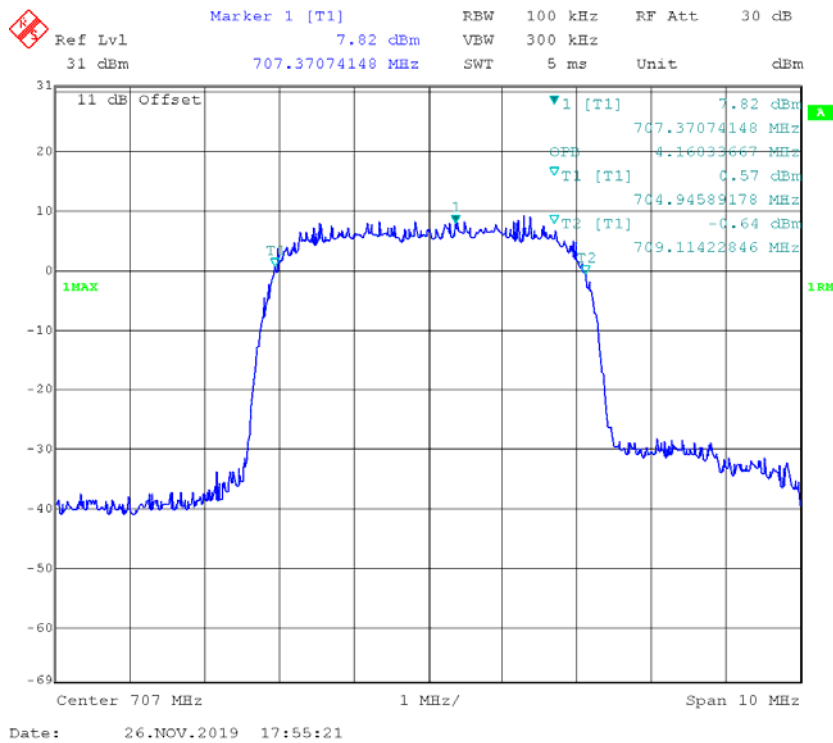

Upper 700 Band:

GSM Input

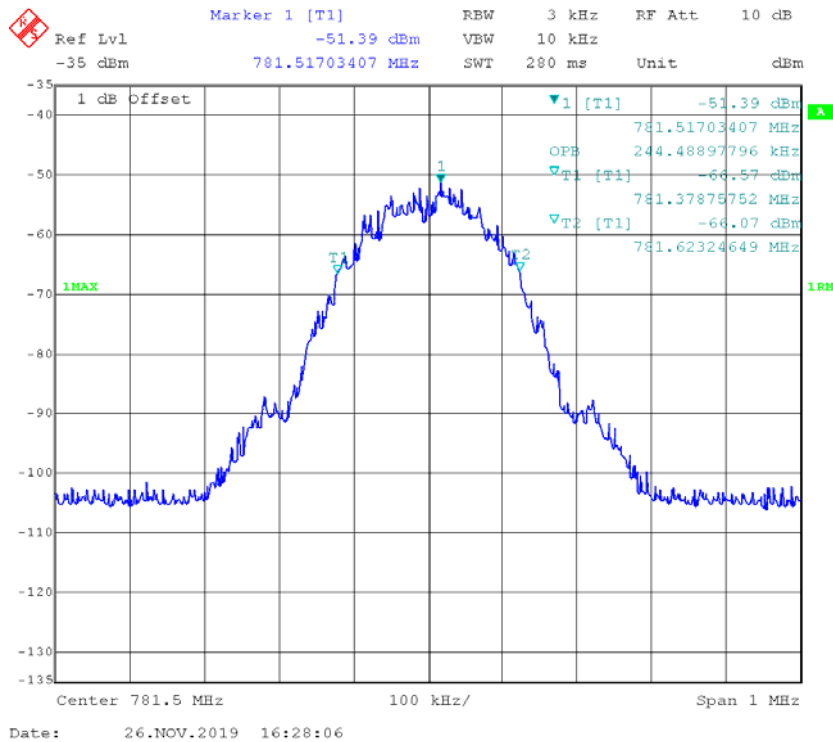

GSM Output

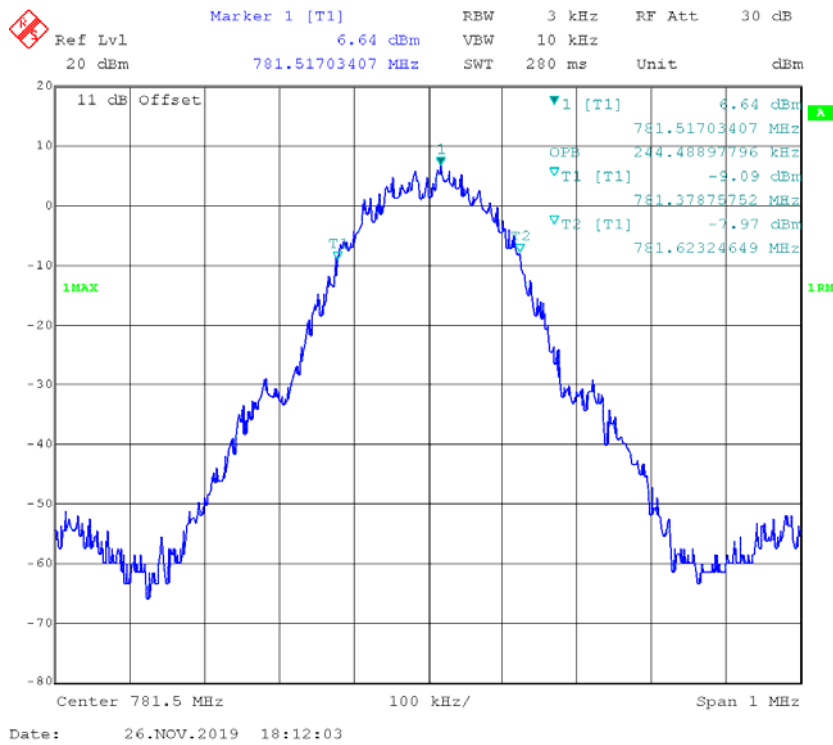

CDMA Input

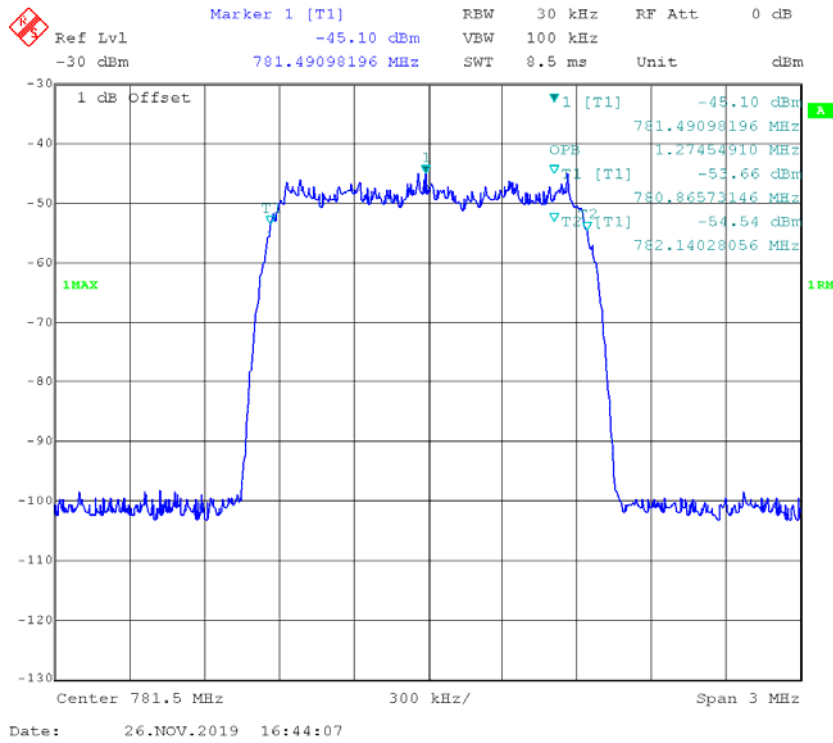

CDMA Output

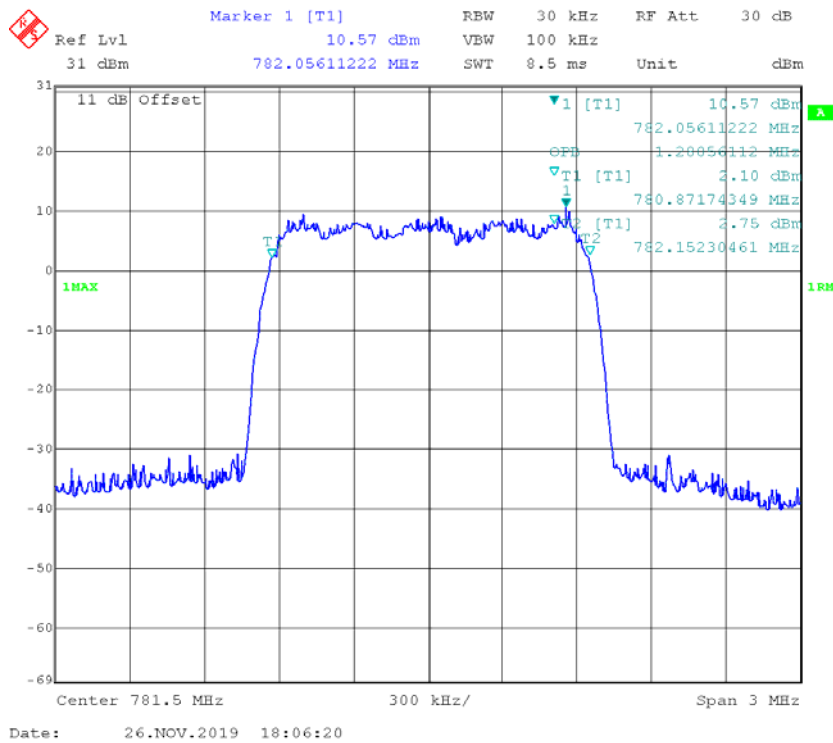

WCDMA Input

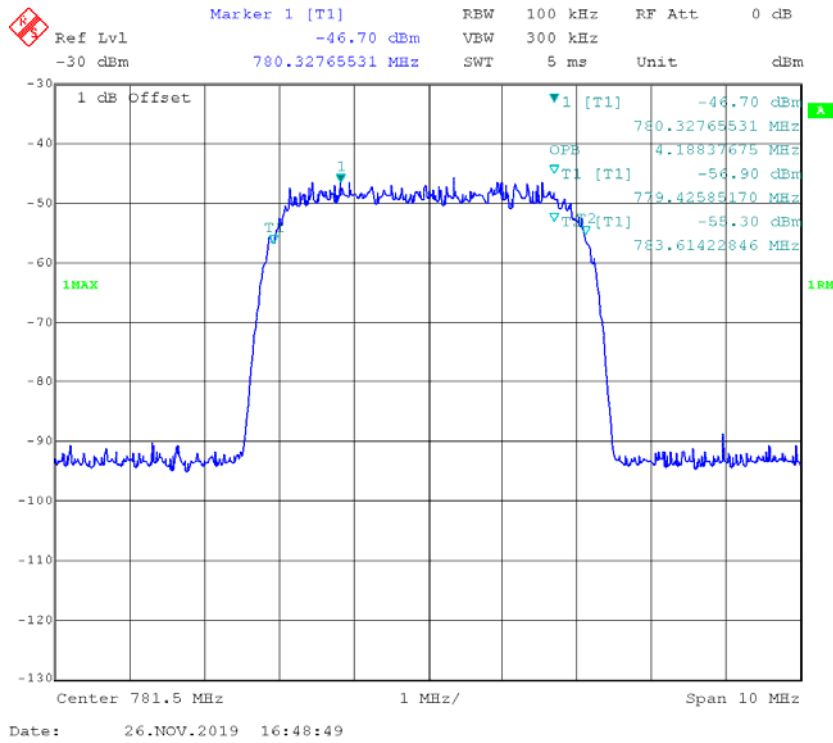

WCDMA Output

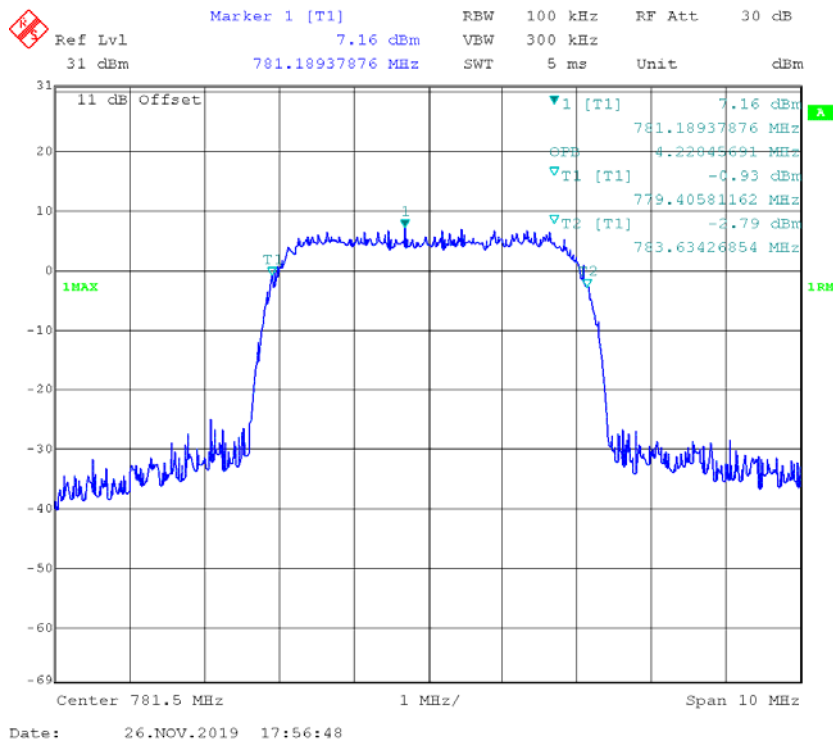

Cellular Band:

GSM Input

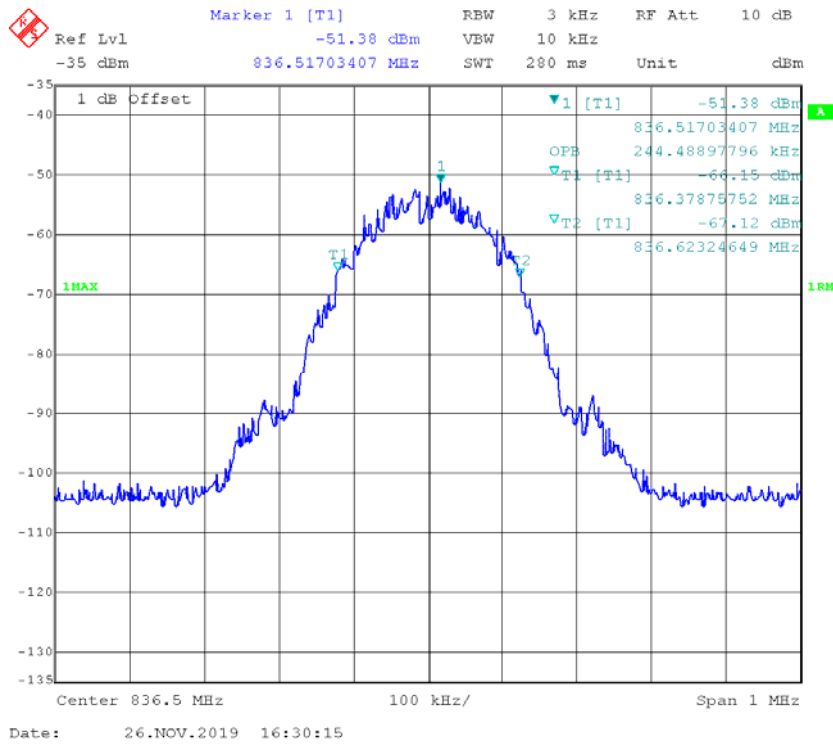

GSM Output

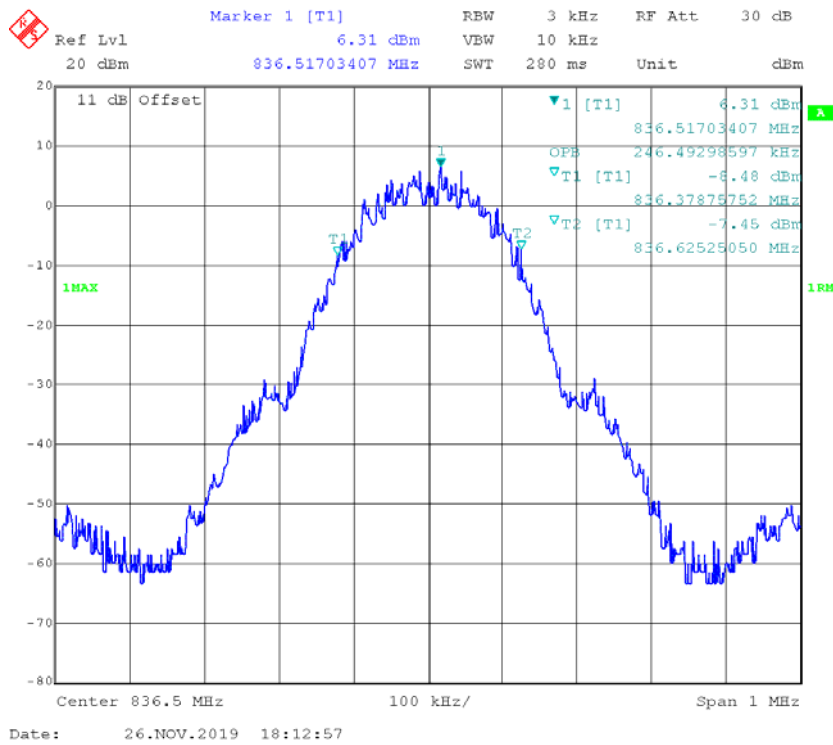

CDMA Input

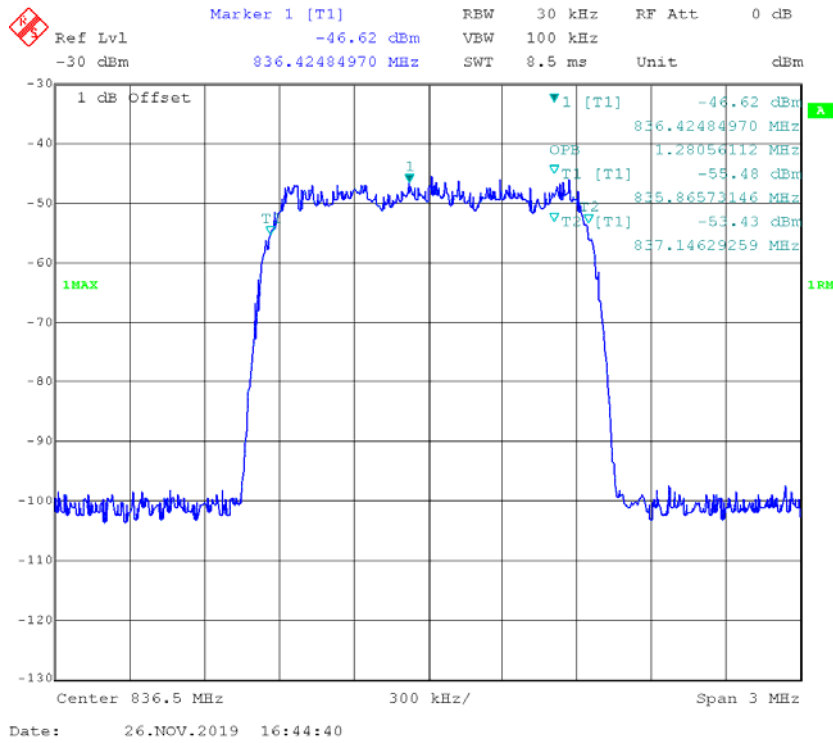

CDMA Output

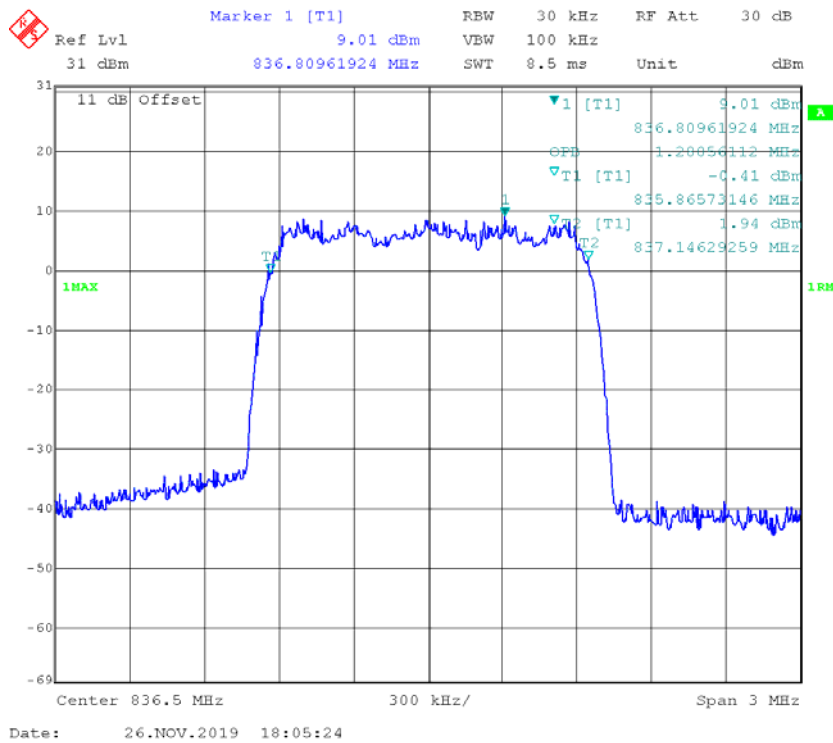

WCDMA Input

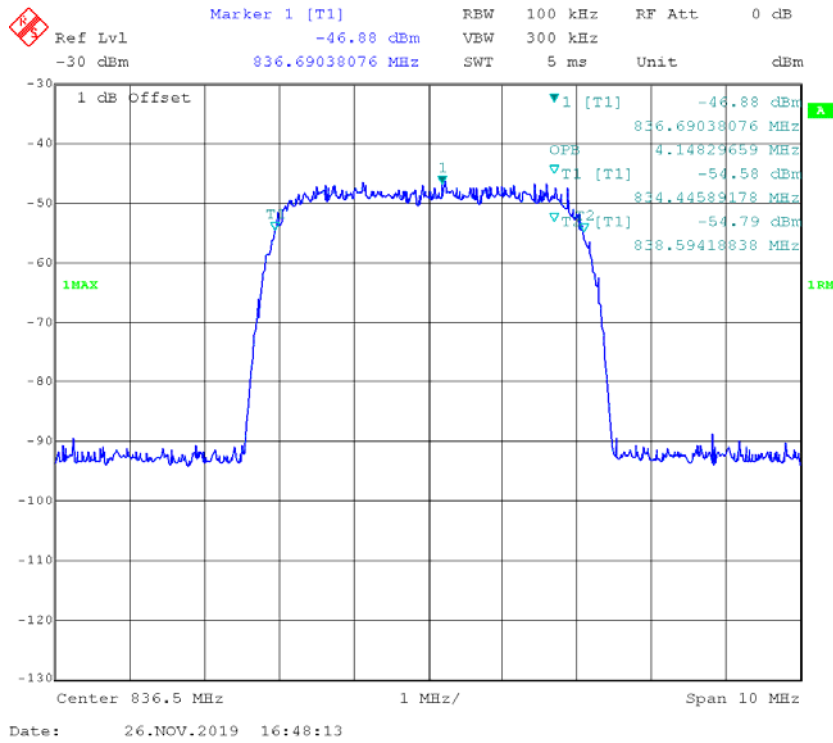

WCDMA Output

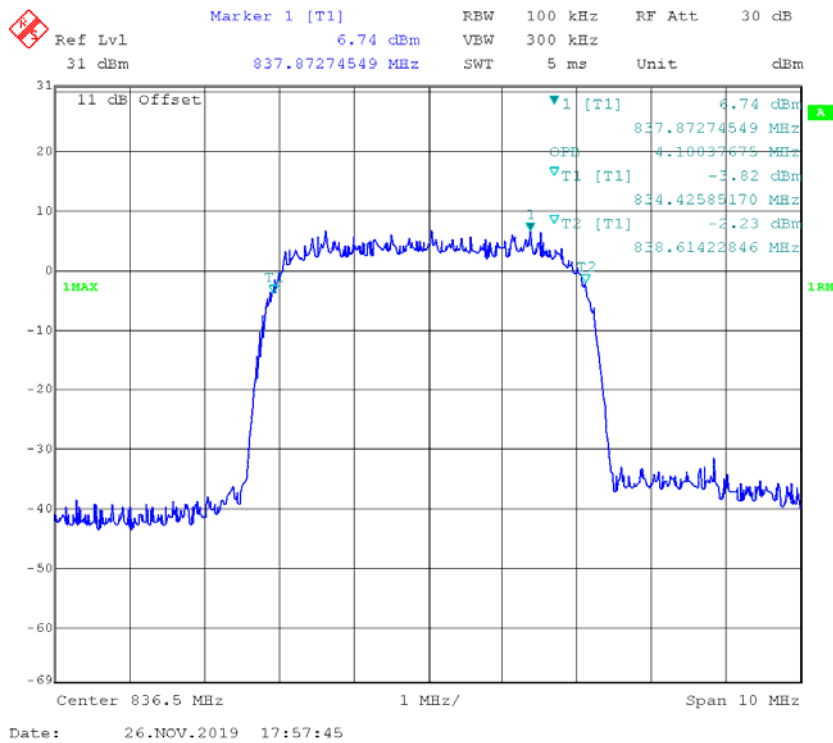

AWS Band:

GSM Input

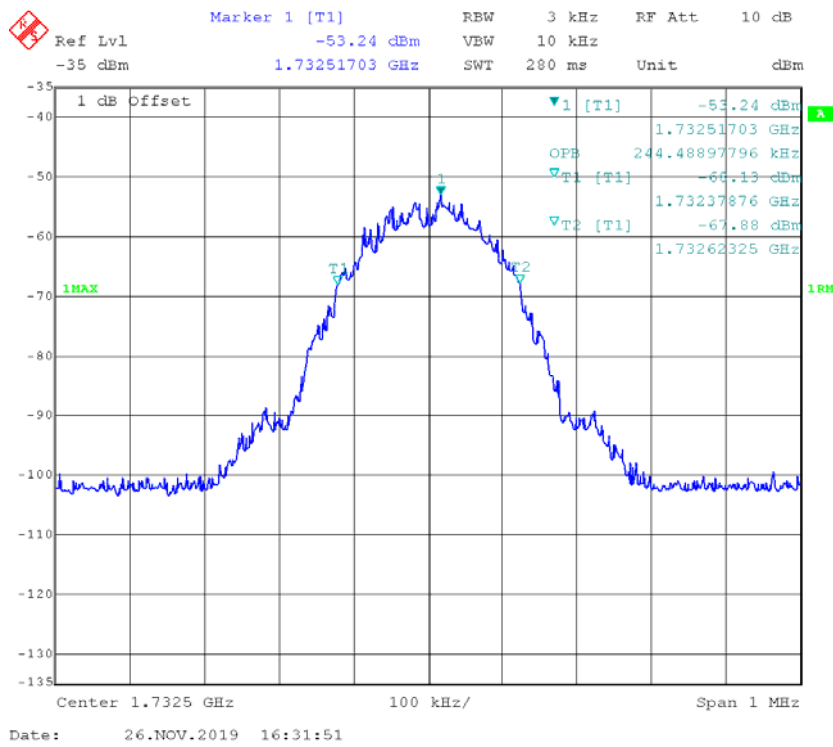

GSM Output

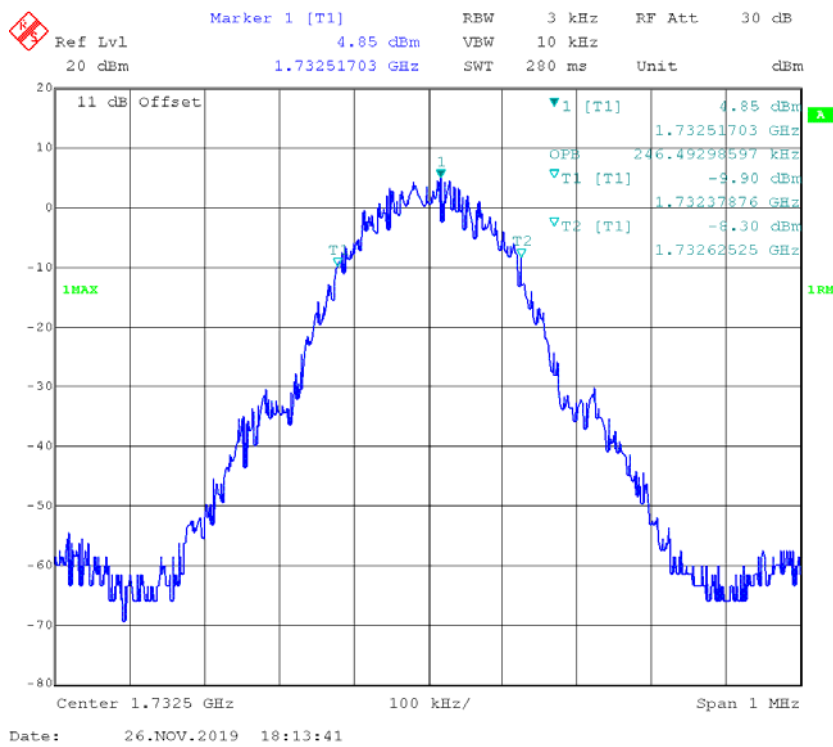

CDMA Input

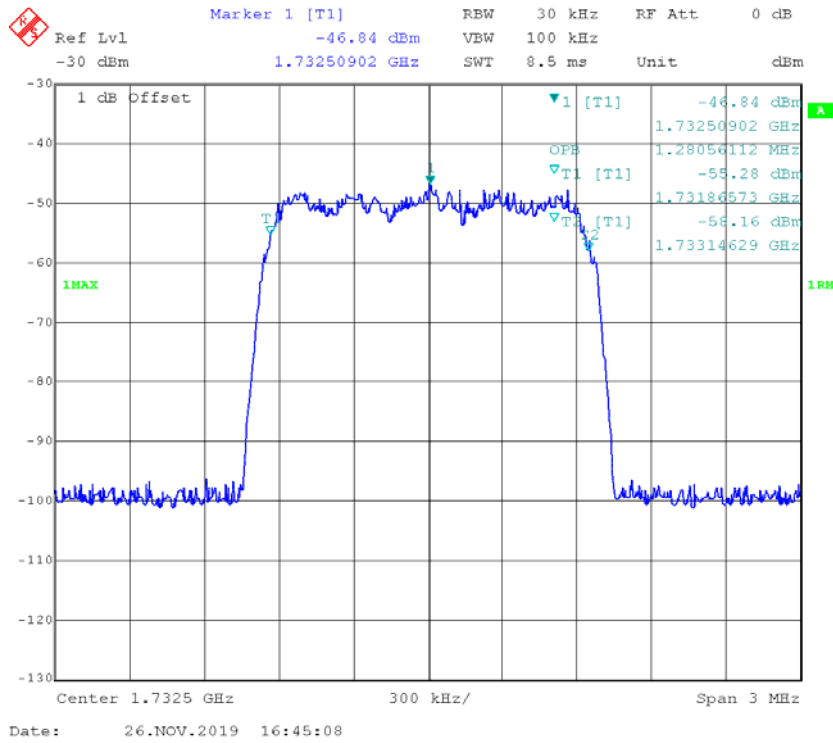

CDMA Output

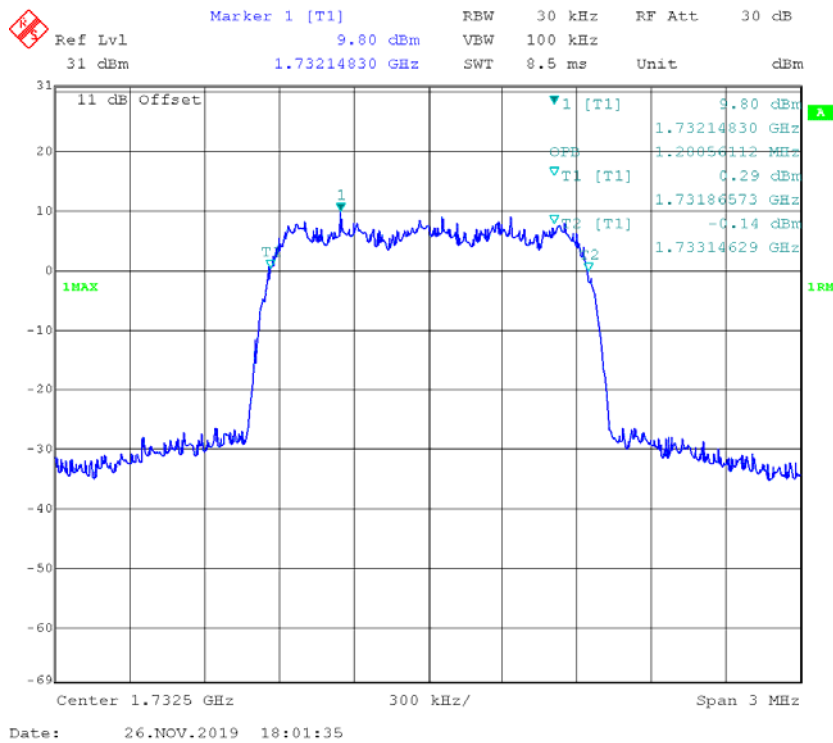

WCDMA Input

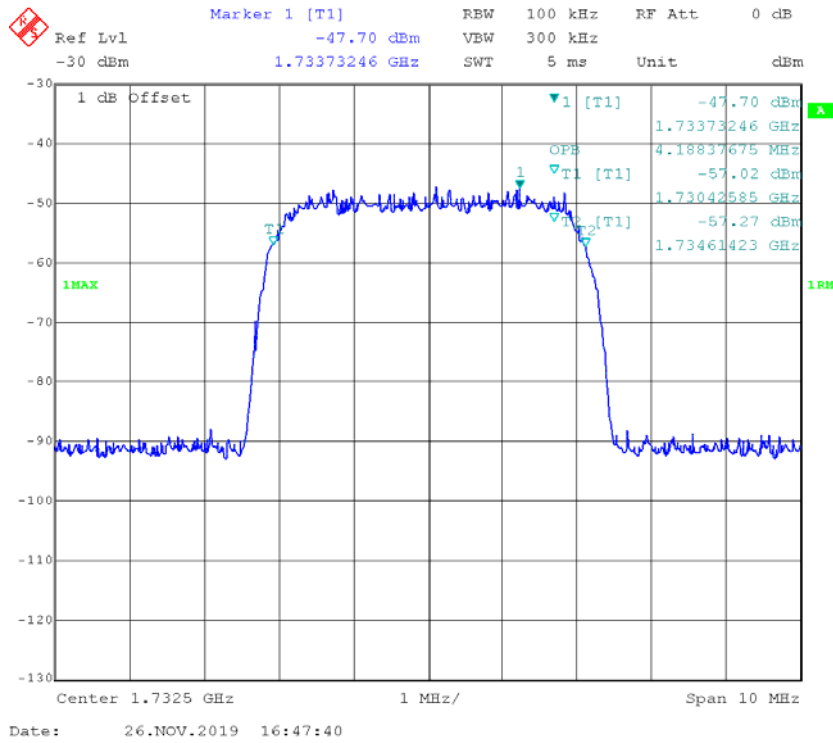

WCDMA Output

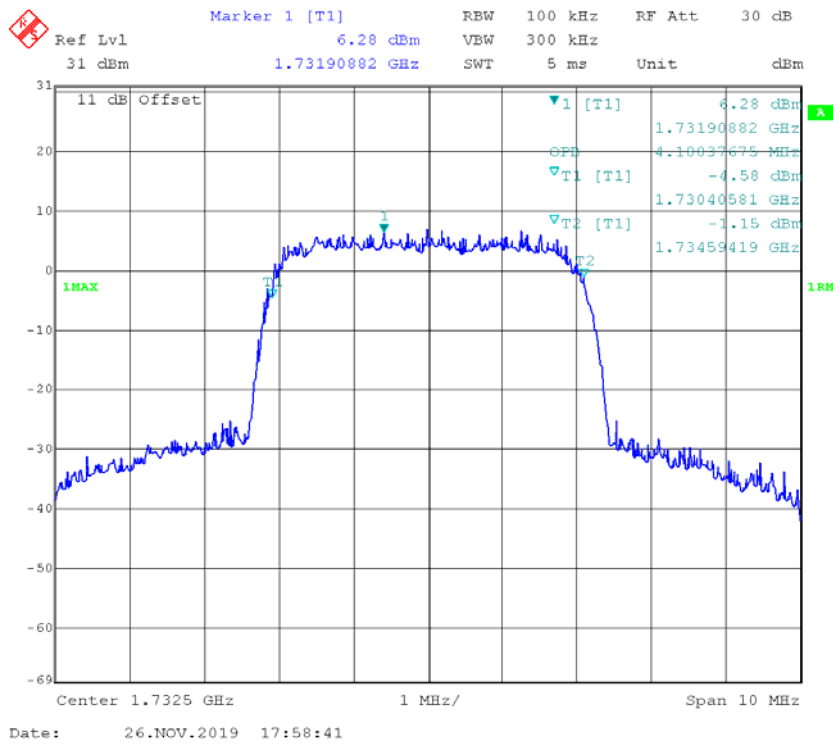

PCS Band:

GSM Input

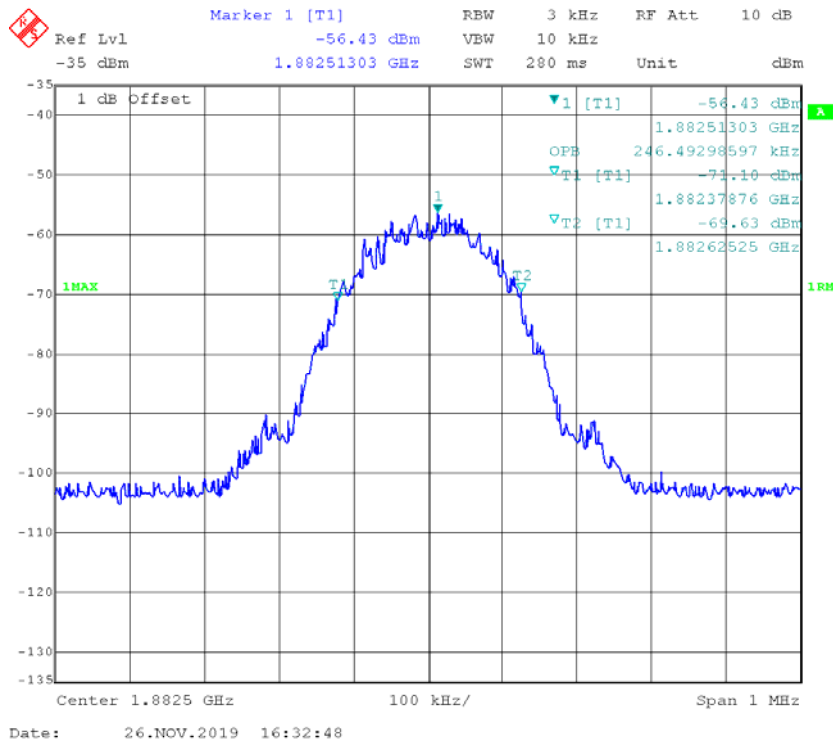

GSM Output

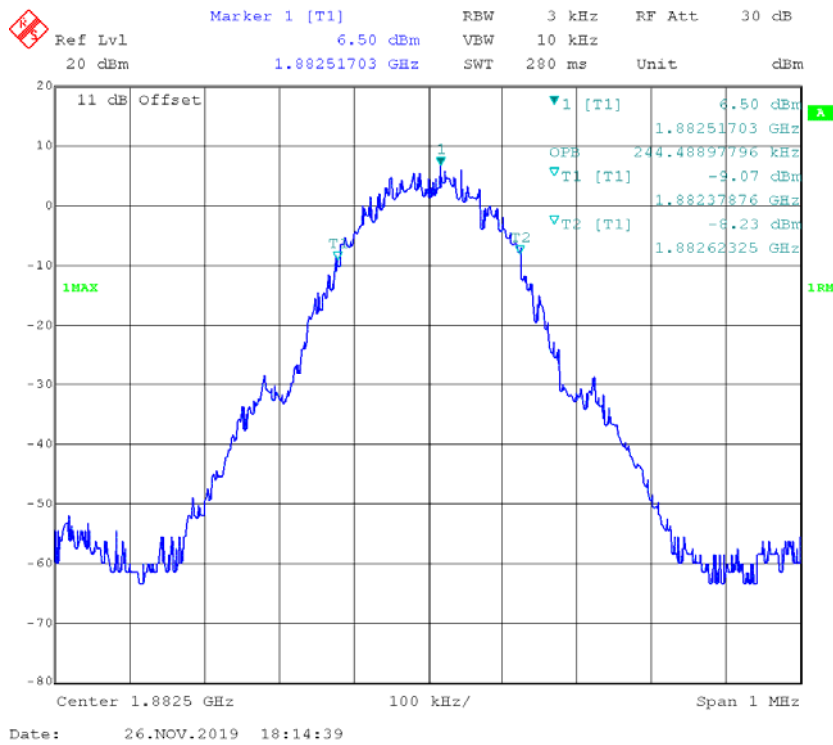

CDMA Input

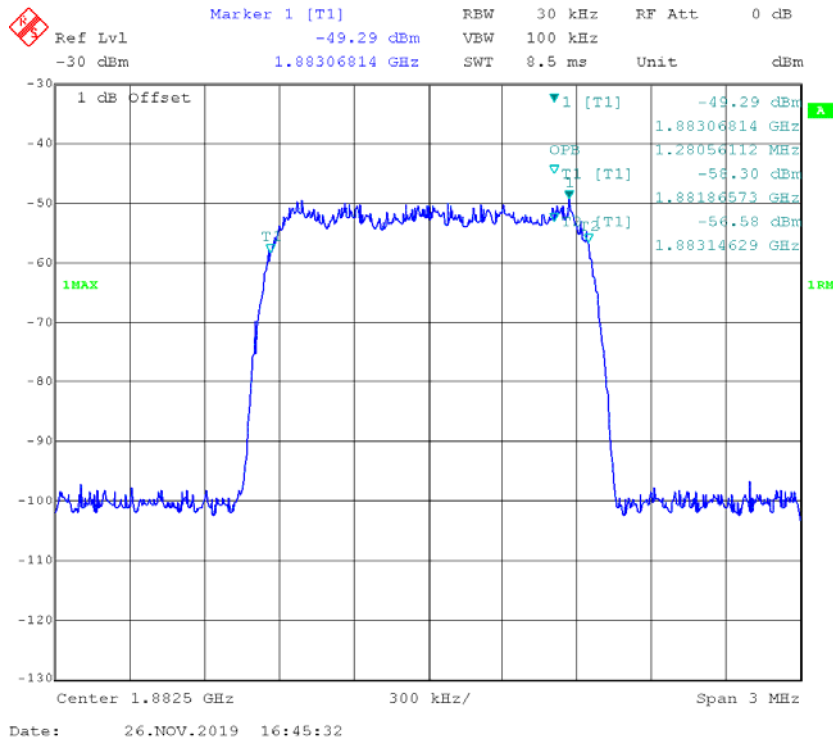

CDMA Output

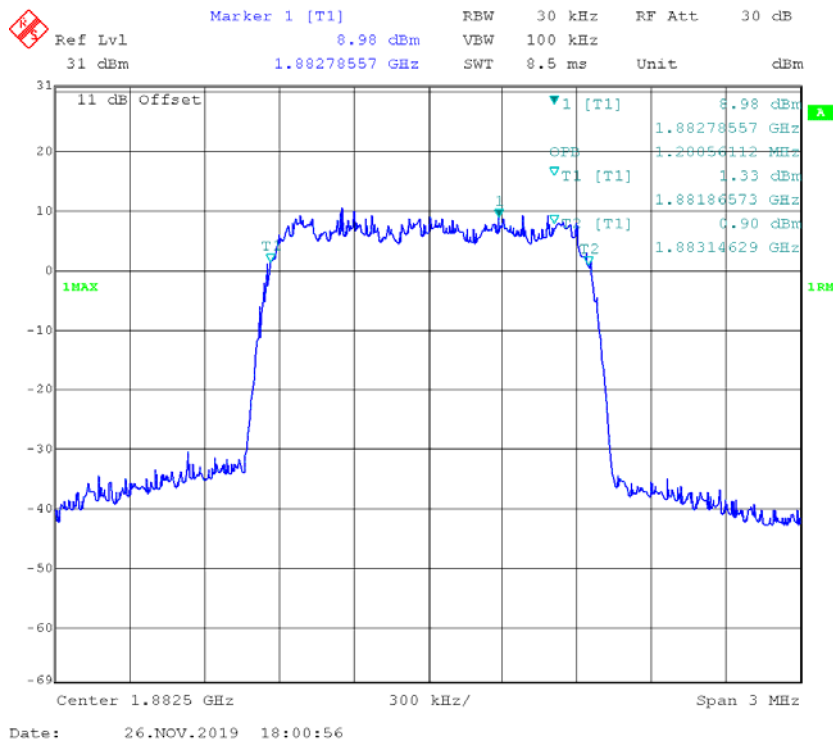

WCDMA Input

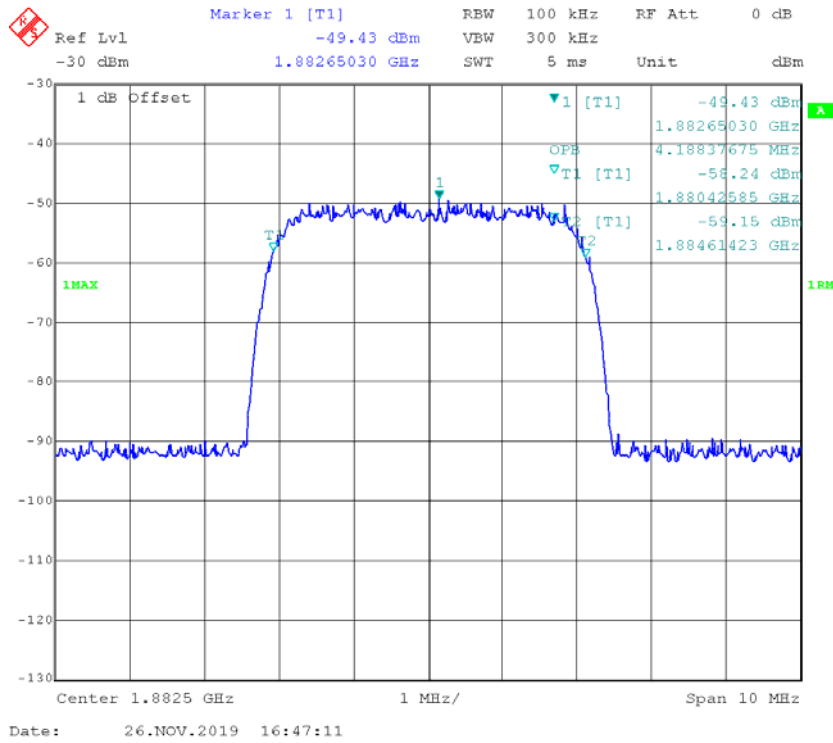

WCDMA Output

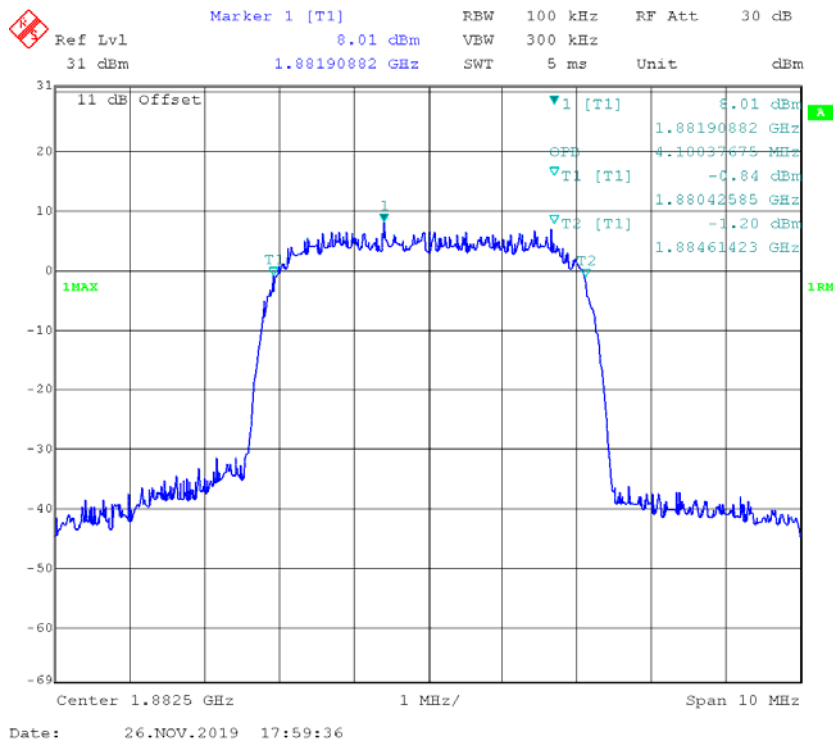

**Downlink:
Lower 700 Band:**

GSM Input

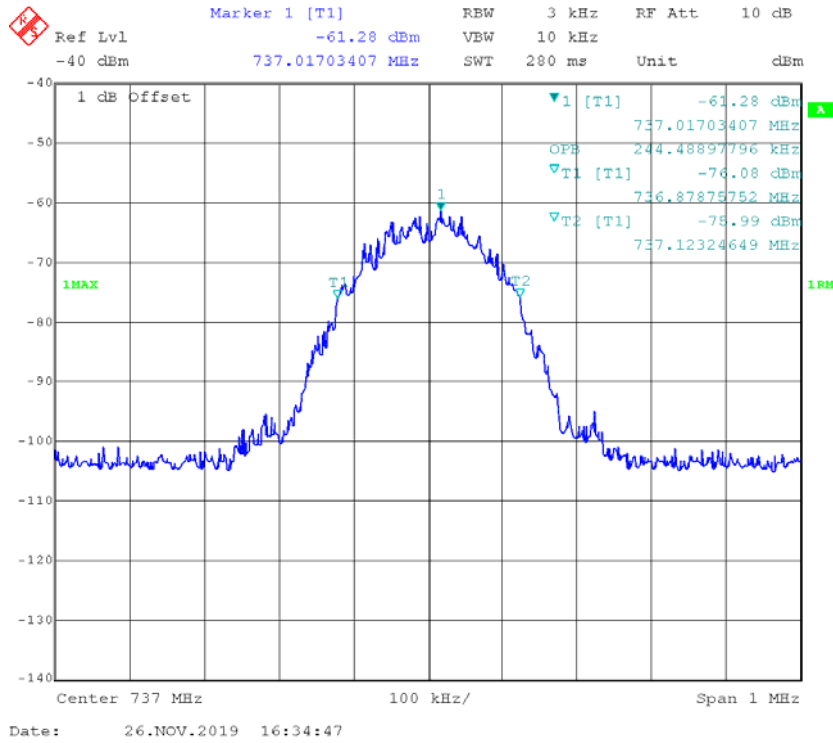

GSM Output

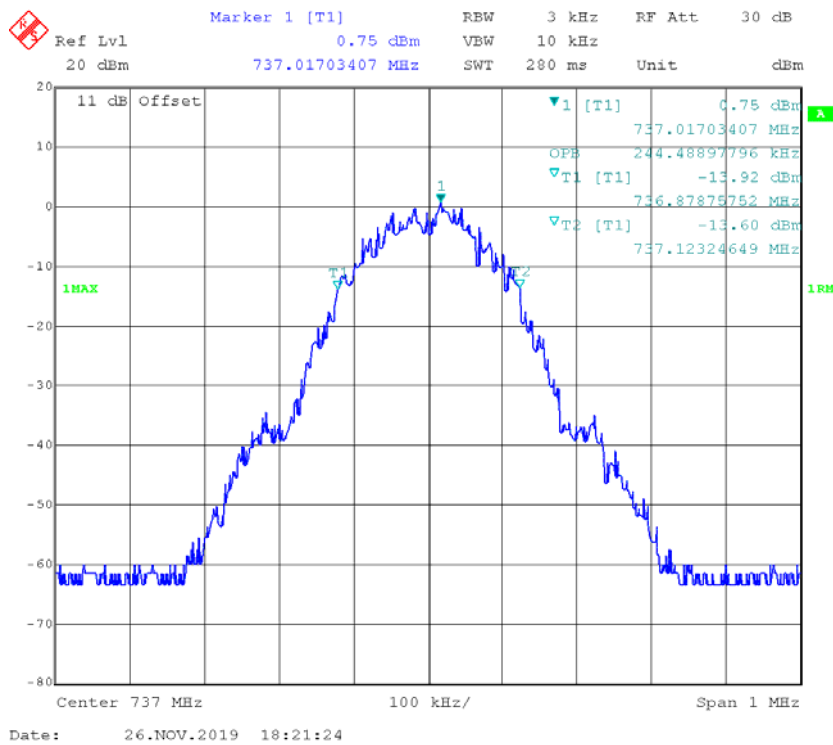

CDMA Input

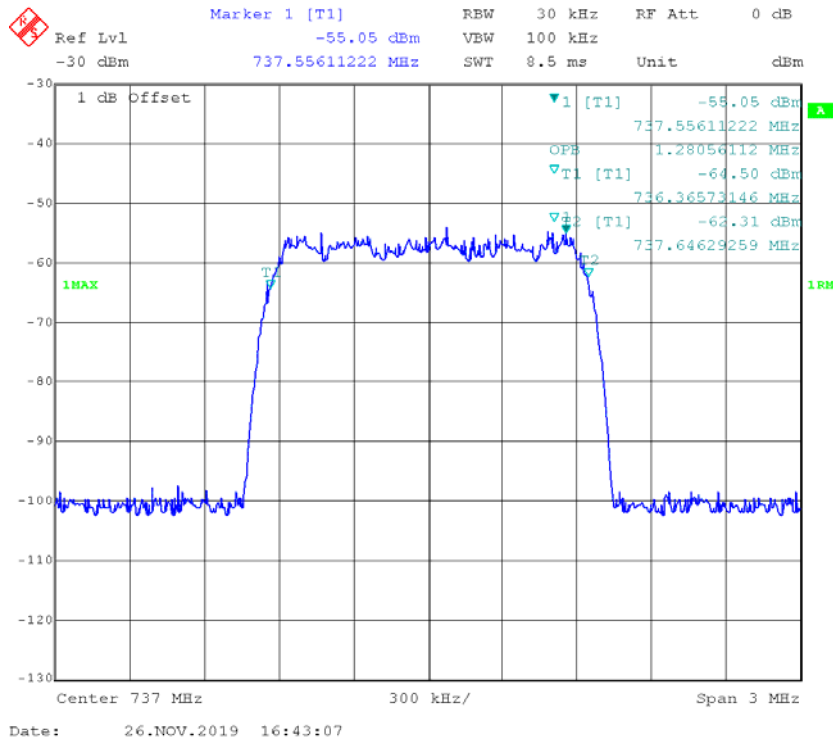

CDMA Output

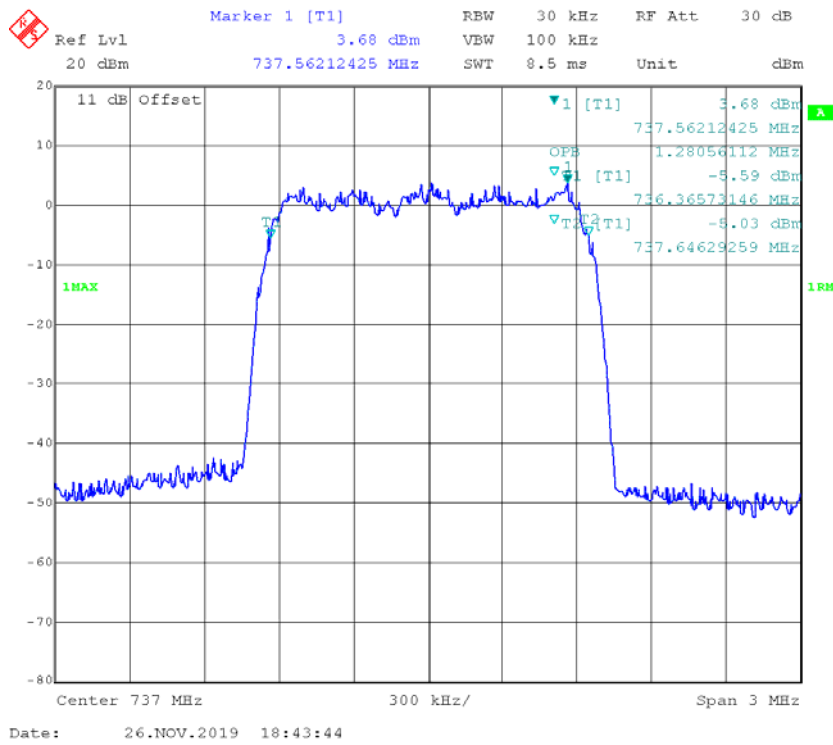

WCDMA Input

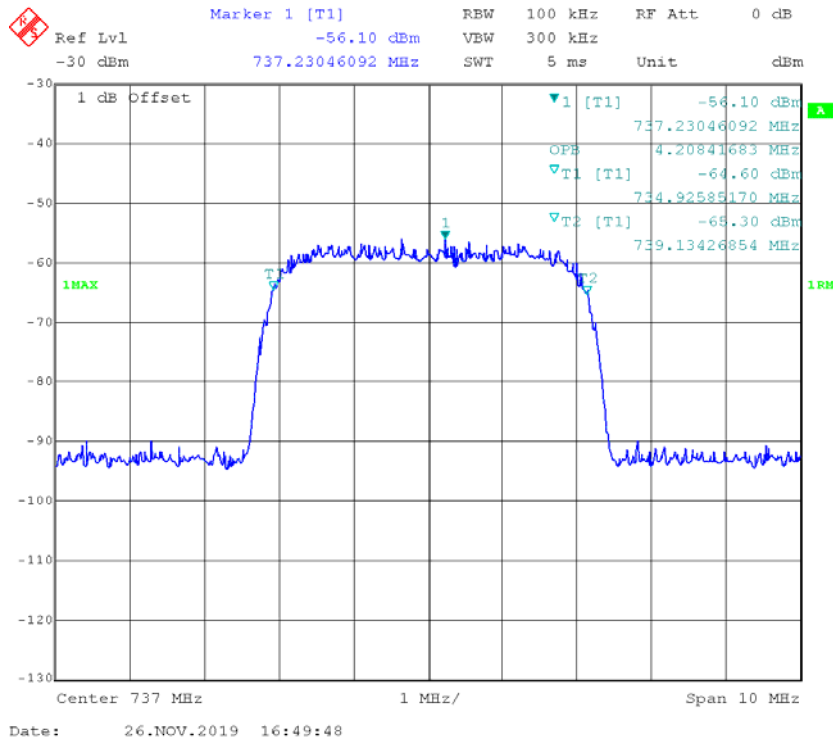

WCDMA Output

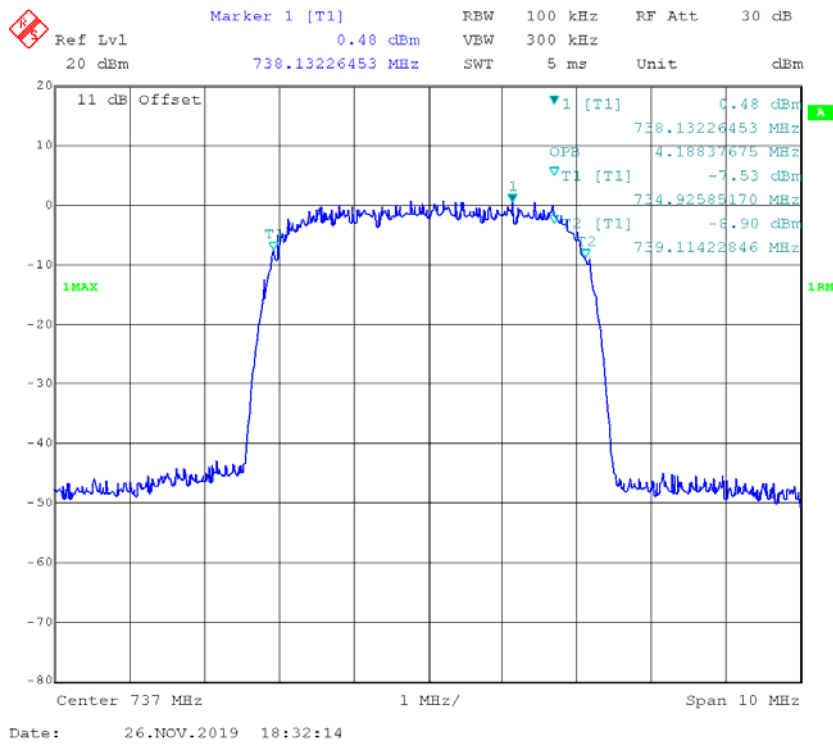

Upper 700 Band:

GSM Input

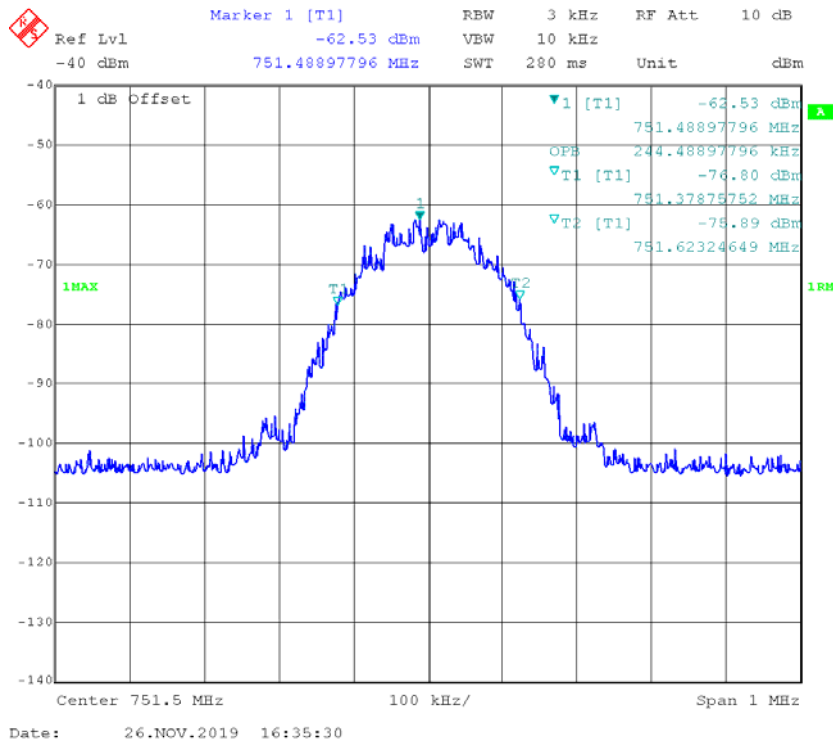

GSM Output

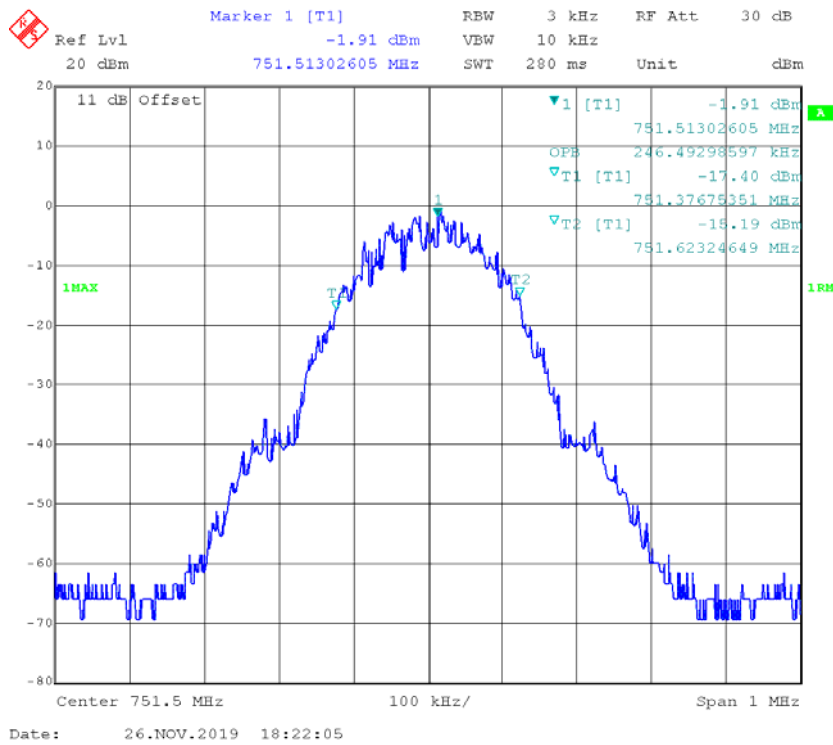

CDMA Input

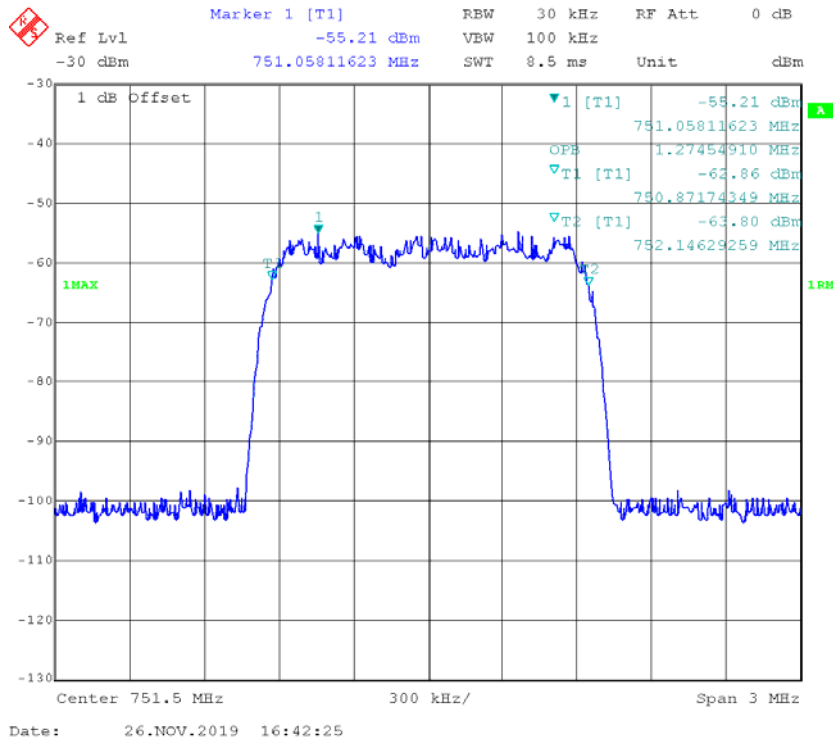

CDMA Output

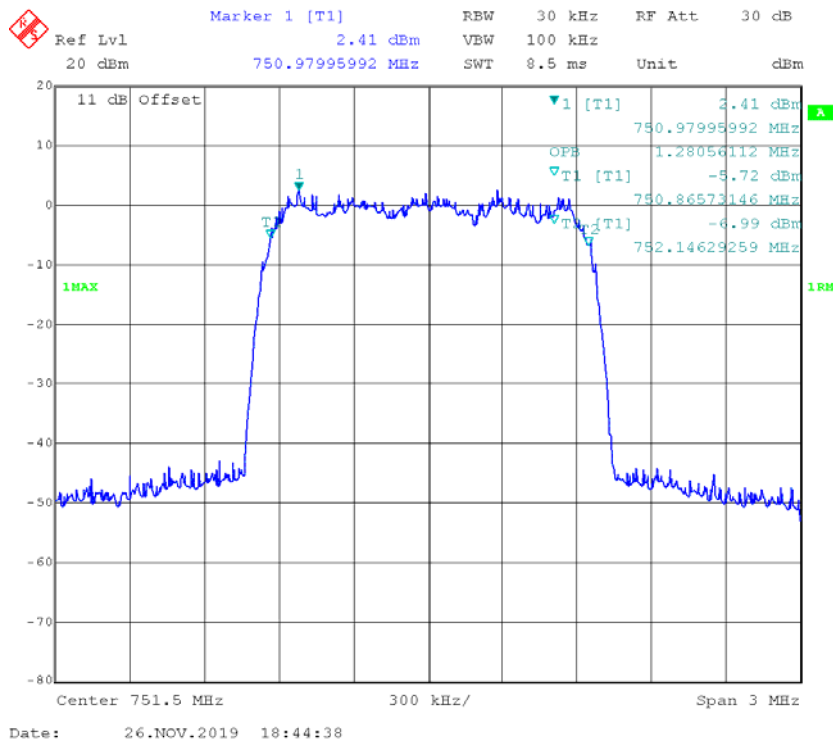

WCDMA Input

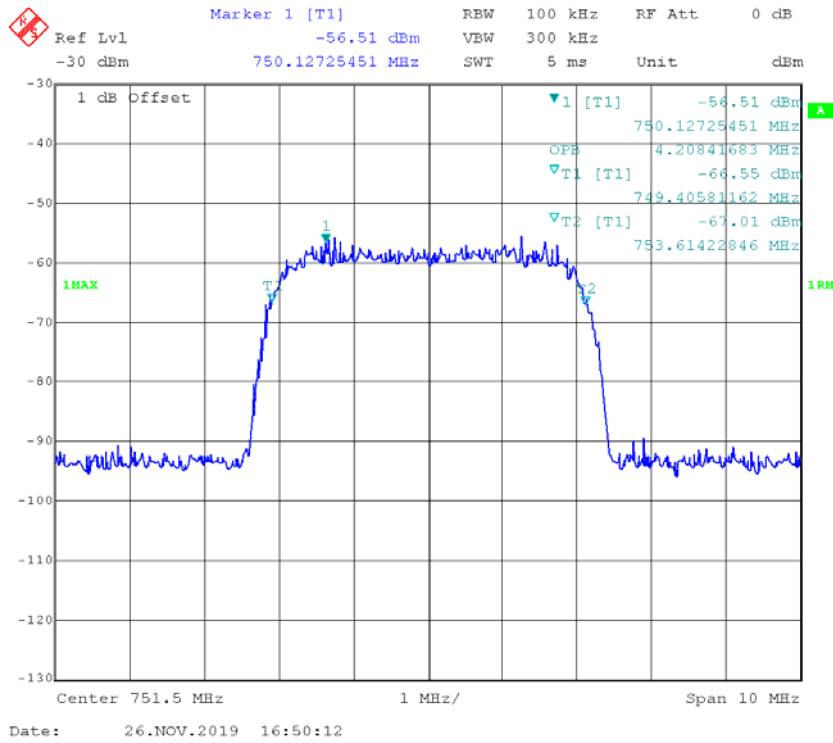

WCDMA Output

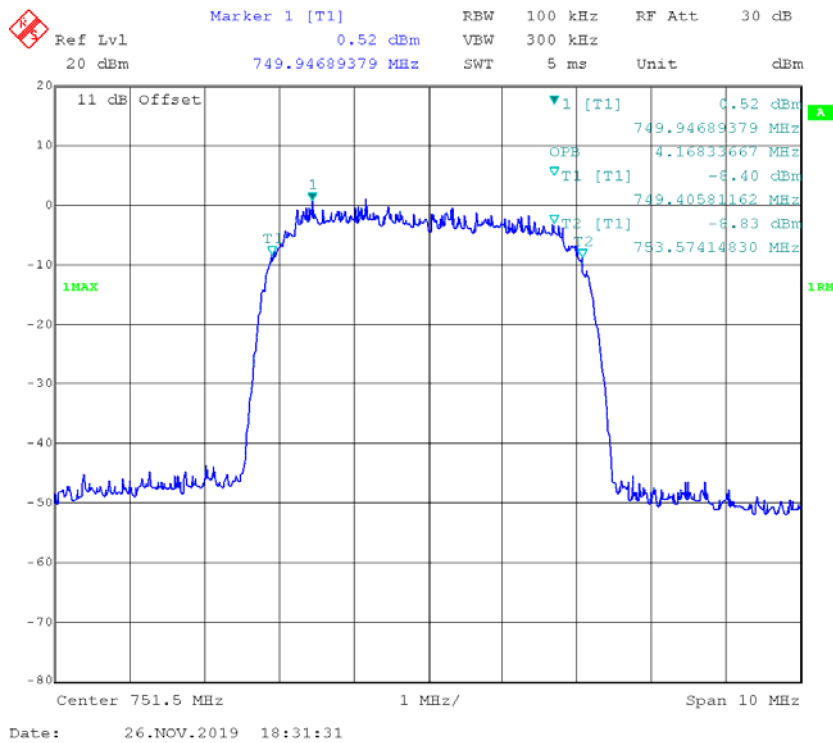

Cellular Band:

GSM Input

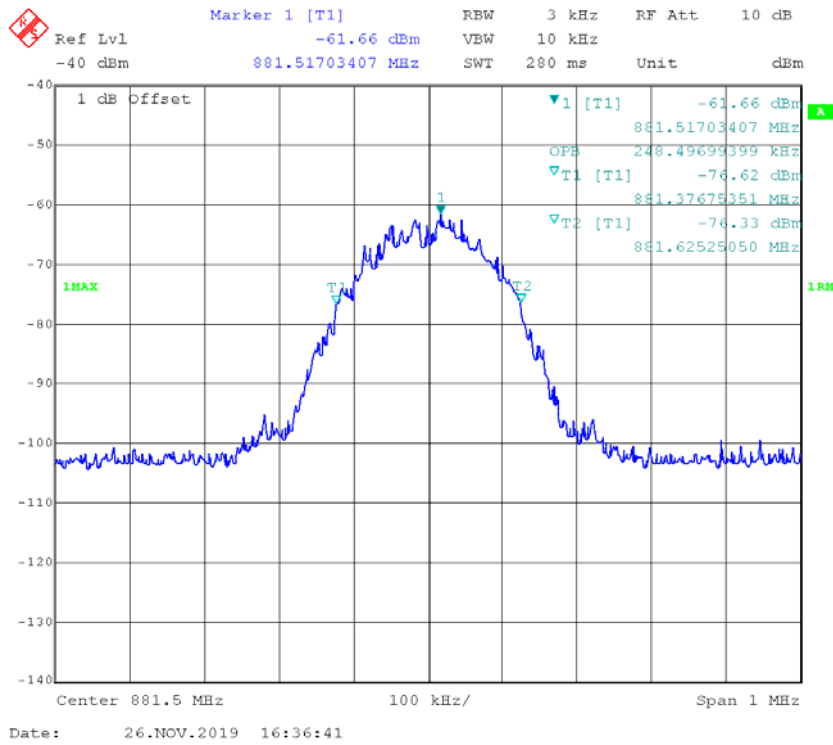

GSM Output

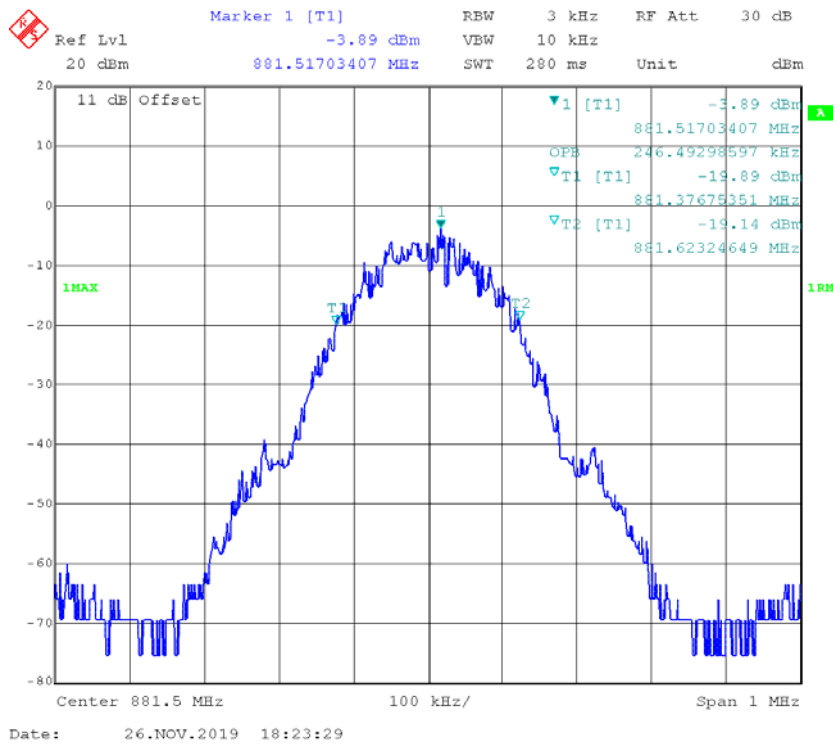

CDMA Input

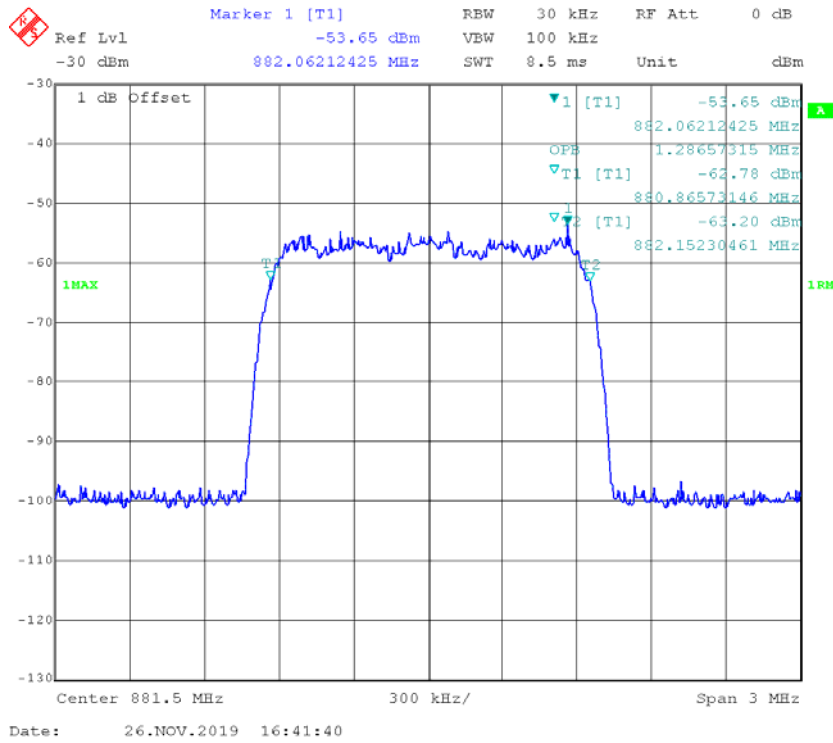

CDMA Output

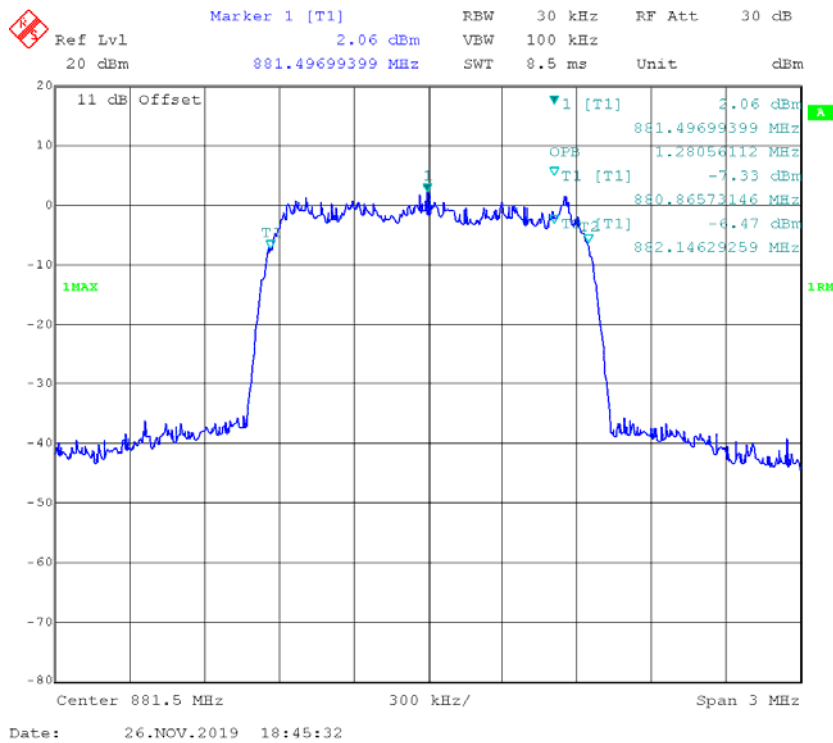

WCDMA Input

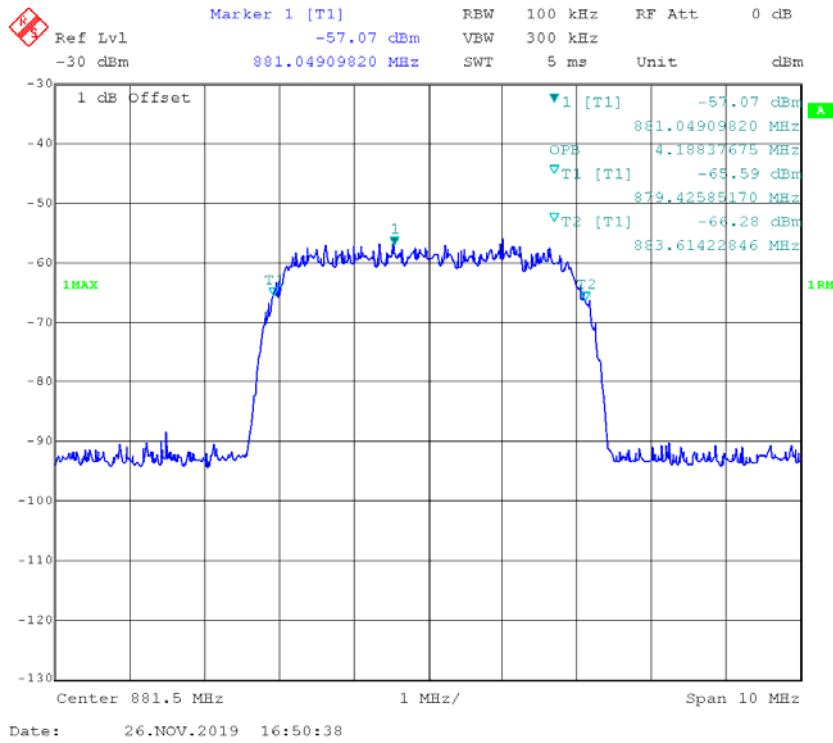

WCDMA Output

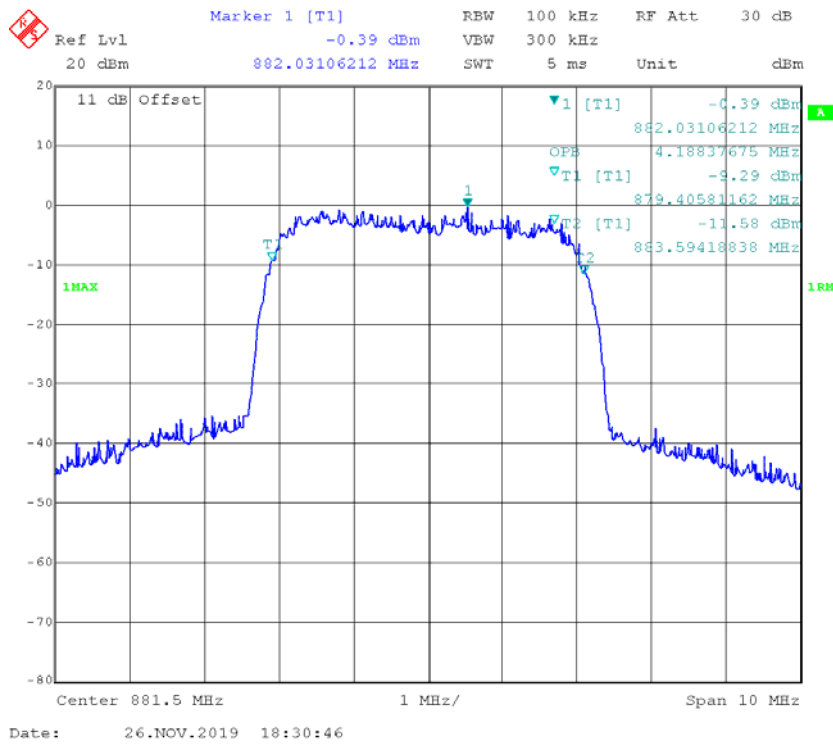

AWS Band:

GSM Input

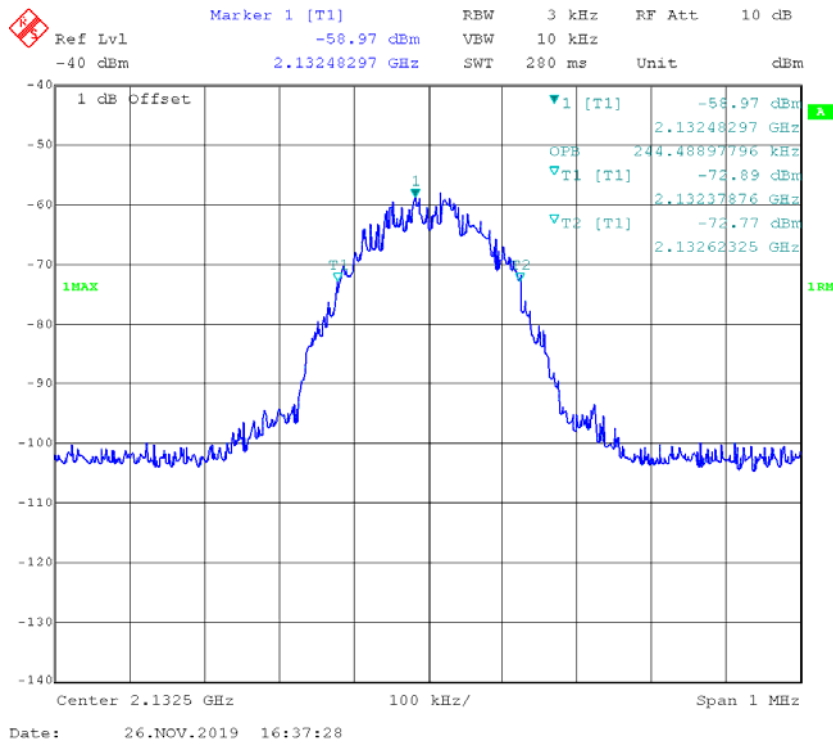

GSM Output

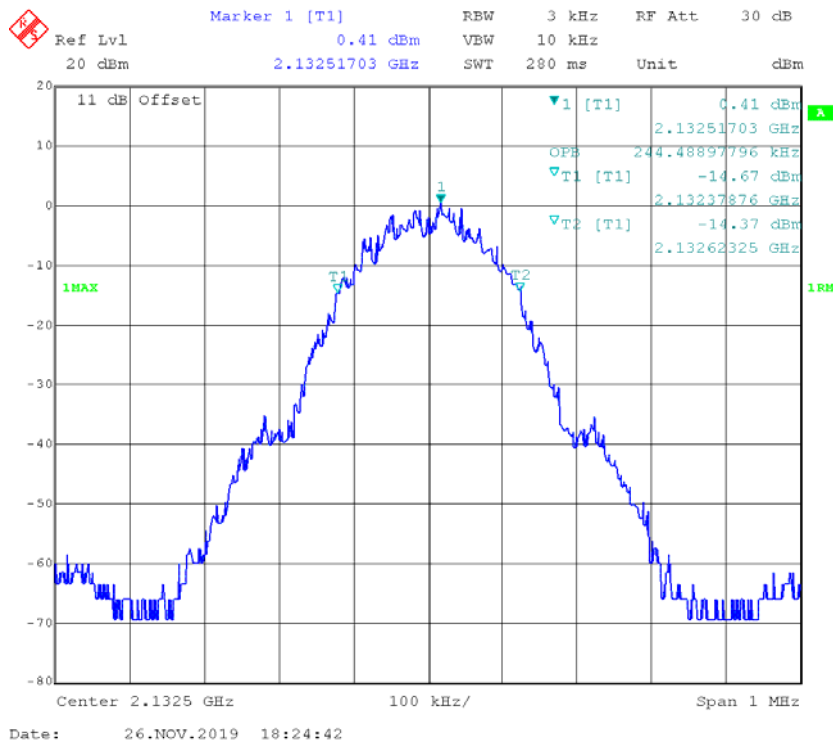

CDMA Input

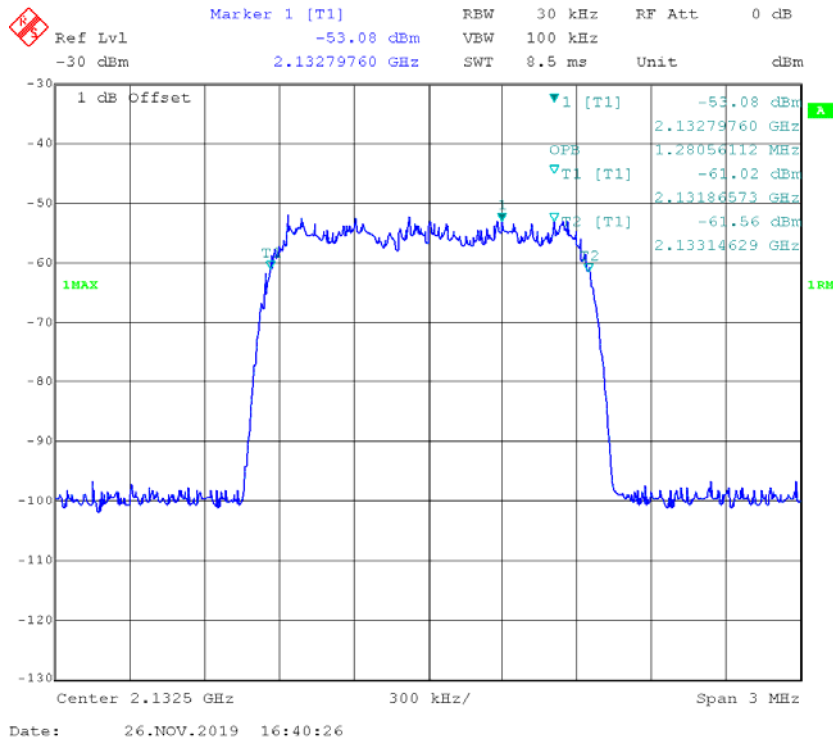

CDMA Output

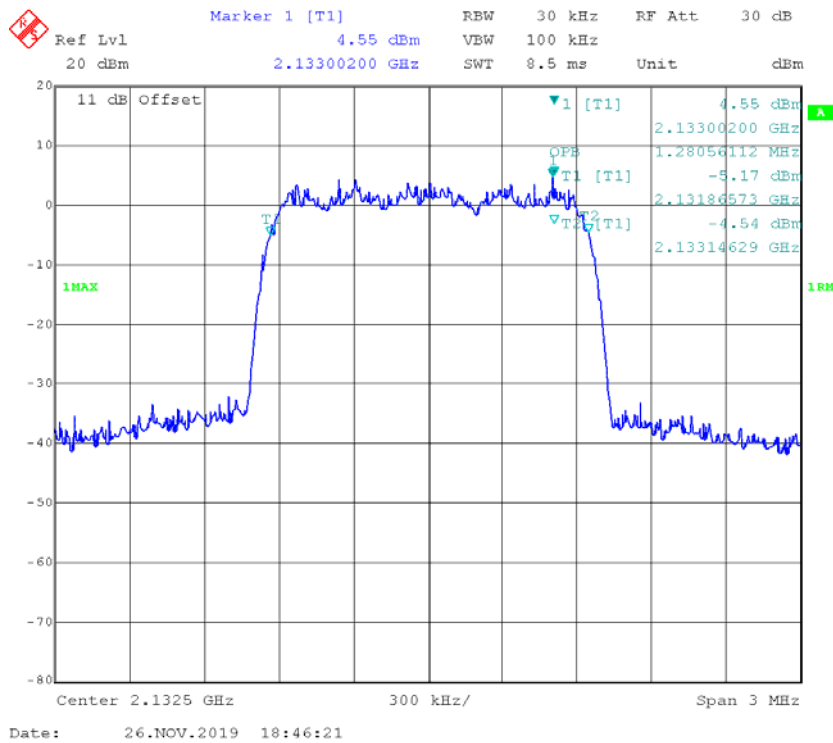

WCDMA Input

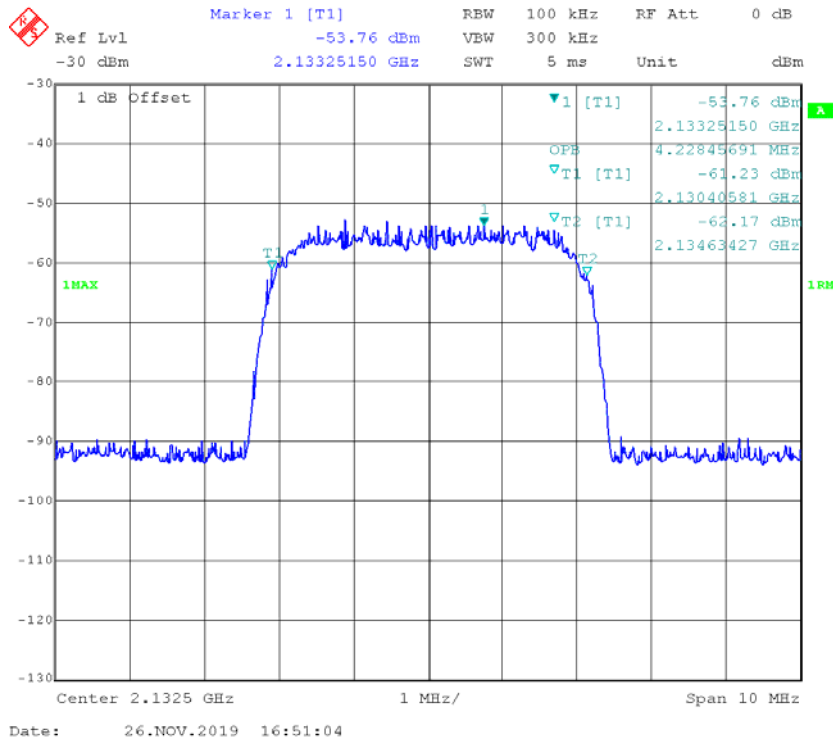

WCDMA Output

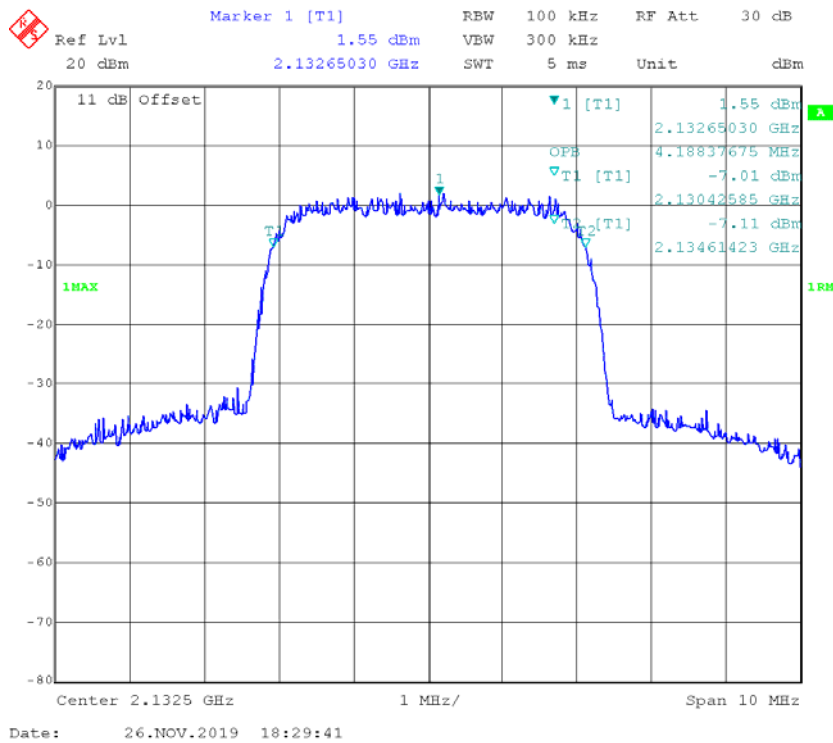

PCS Band:

GSM Input

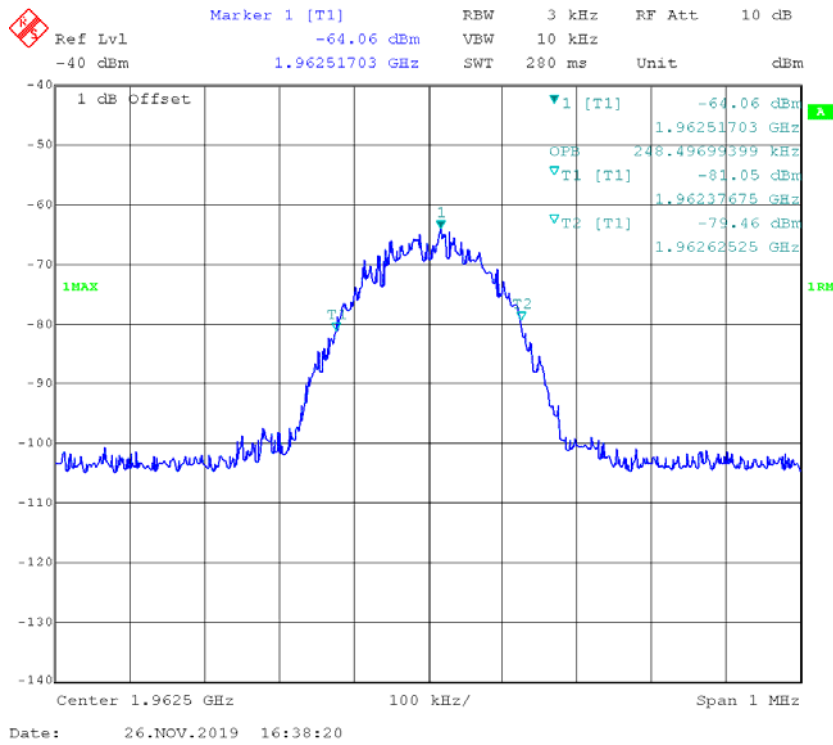

GSM Output

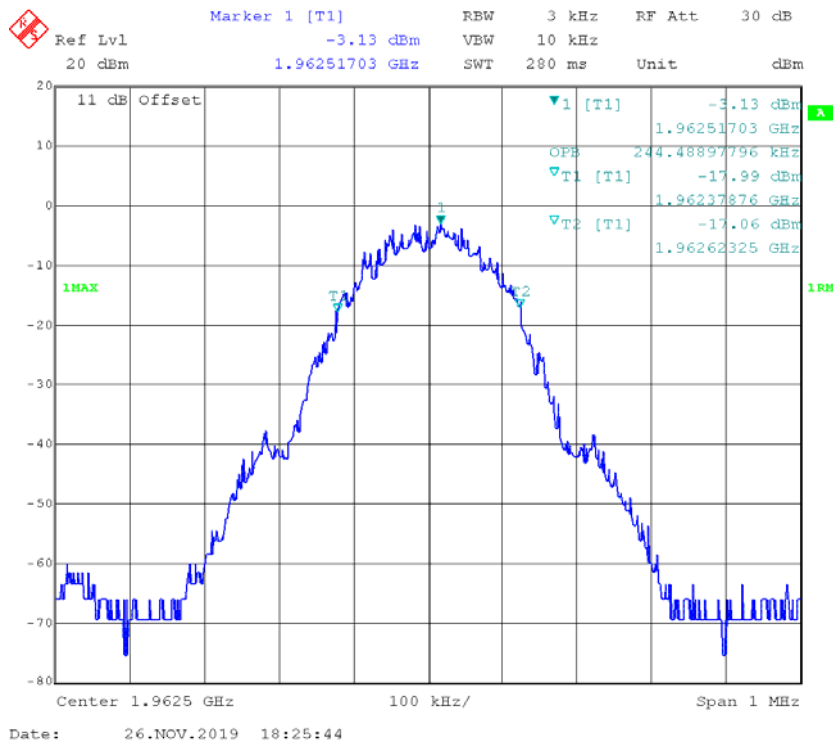

CDMA Input

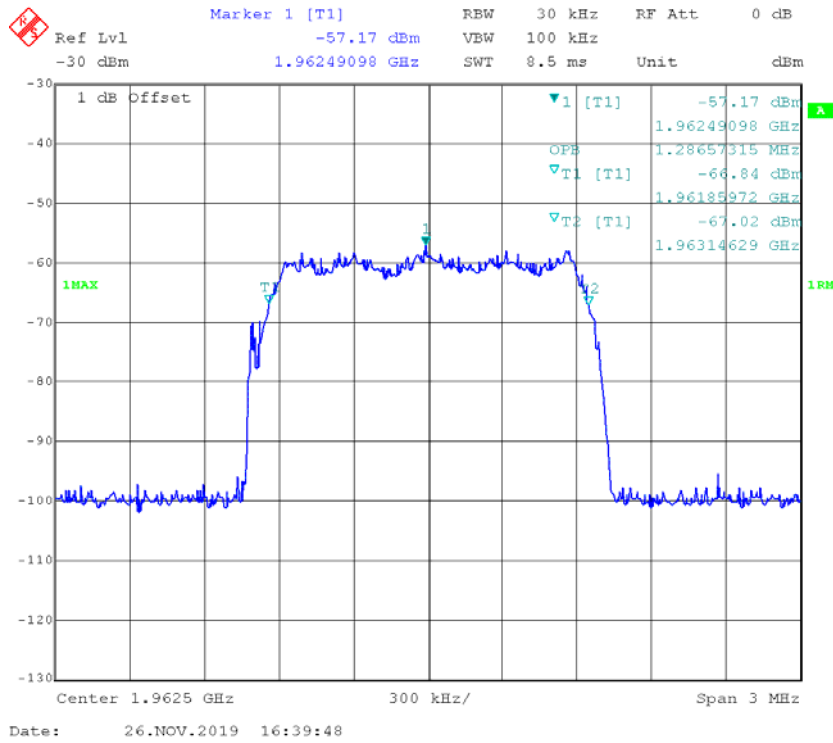

CDMA Output

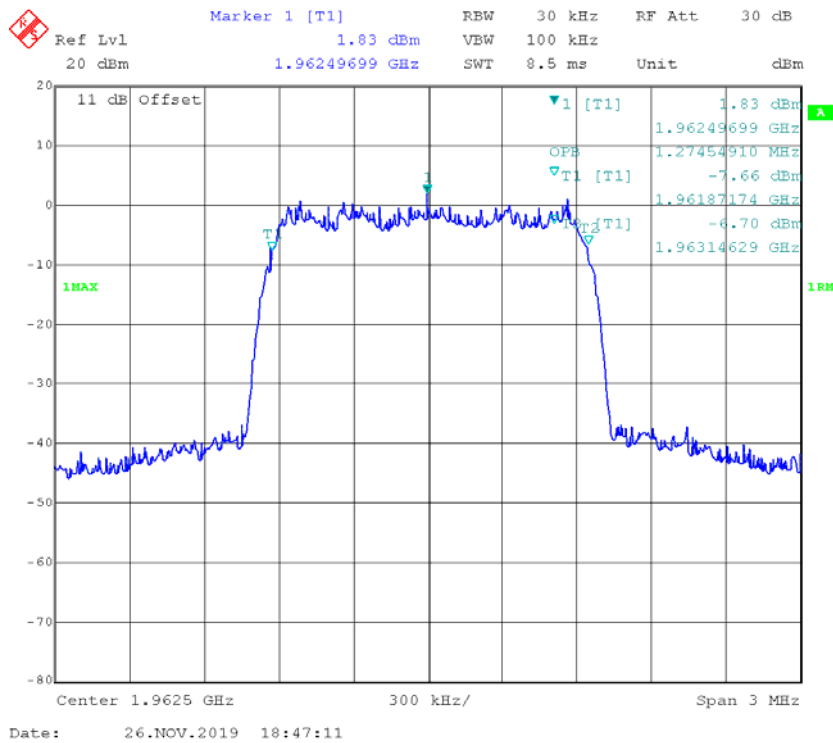

WCDMA Input

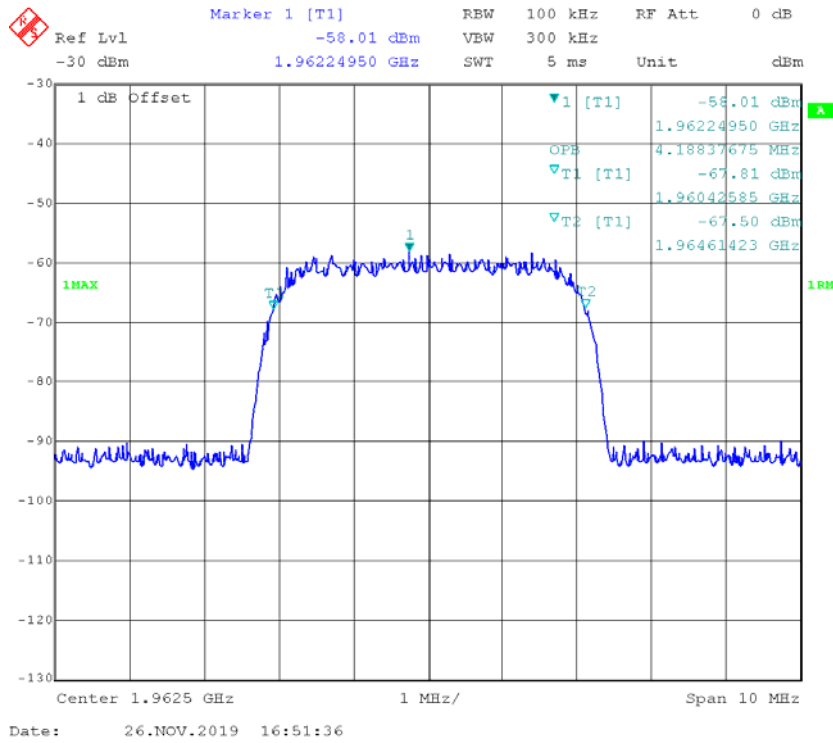

WCDMA Output

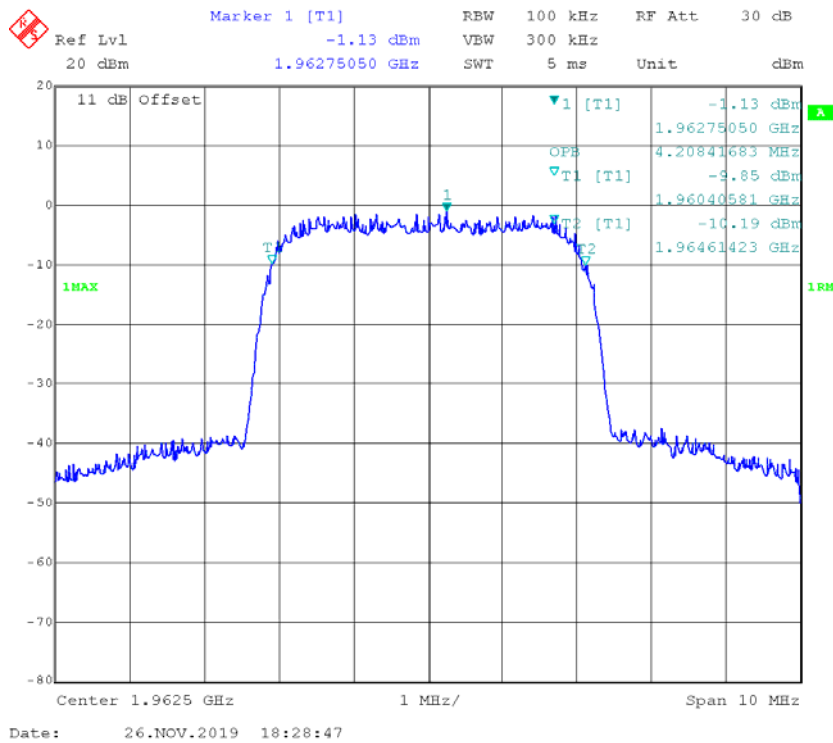

§ 20.21(e)(8)(ii)(A) & §20.21(e)(4) - OSCILLATION DETECTION

Applicable Standards

Rule paragraph(s): § 20.21(e)(8)(ii)(A) Anti-Oscillation, §20.21(e)(4) Self-monitoring

For this measurement two EUTs will be permitted, one operating in a normal mode and the second operating in a test mode that is capable of disabling the uplink inactivity squelching and or a reduction of the time between restarts to 5 seconds. This will greatly decrease the test time required.

NOTE — Consumer boosters certified as direct connection mobile boosters having gain of less than or equal to 15 dB are exempt from compliance to testing procedures in 7.11.3 and 7.11.4.

Test Procedure

According to KDB 935210 D03 Signal Booster Measurements v04r03, §7.11.2 Oscillation restart tests and §7.11.3 Test procedure for measuring oscillation mitigation or shutdown

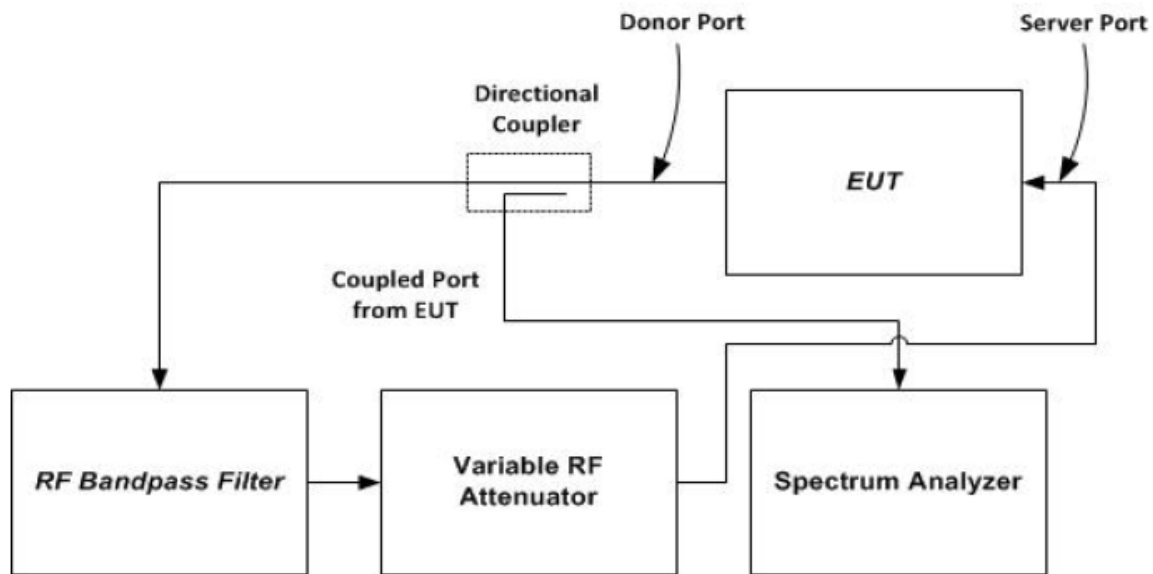

Figure 7 – Oscillation detection instrumentation test setup

Test Data

Environmental Conditions

Temperature:	25.9 °C
Relative Humidity:	45 %
ATM Pressure:	101.4 kPa

The testing was performed by Blake Yang on 2019-11-28.

Test Result: Compliance. Please refer to following table.

Oscillation Restart Time:

Mode	Operation Bands	Detection Time (s)		Power level dBm	Between restart time (s)		Number of restart		Result		
		Reading	Limit		Reading	Limit	Reading	Limit			
Uplink	Lower 700	0.271	≤0.3	22.76	≥60	63.85	5	≤5	Compliance		
	Upper 700	0.271		21.03					64.13	5	Compliance
	Cellular	0.271		21.95					63.79	5	Compliance
	AWS	0.271		18.74					64.46	5	Compliance
	PCS	0.271		15.82					63.30	5	Compliance
Downlink	Lower 700	0.271	≤1	22.81	≥60	62.94	5	≤5	Compliance		
	Upper 700	0.271		21.42					62.28	5	Compliance
	Cellular	0.271		21.99					62.46	5	Compliance
	AWS	0.271		15.13					62.81	5	Compliance
	PCS	0.271		14.67					62.47	5	Compliance

Oscillation restart tests:

Uplink:

Lower 700MHz Band

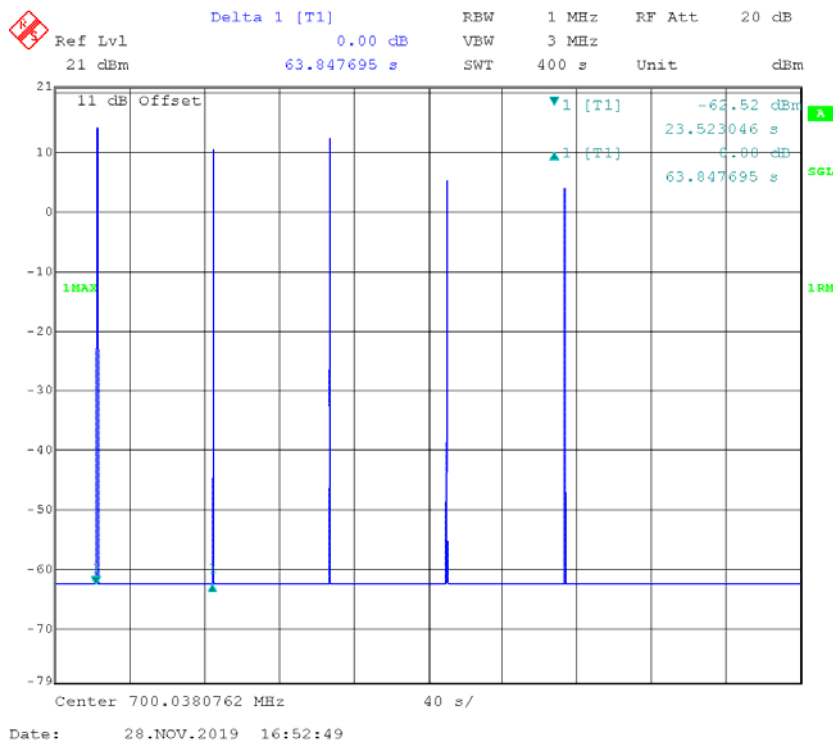
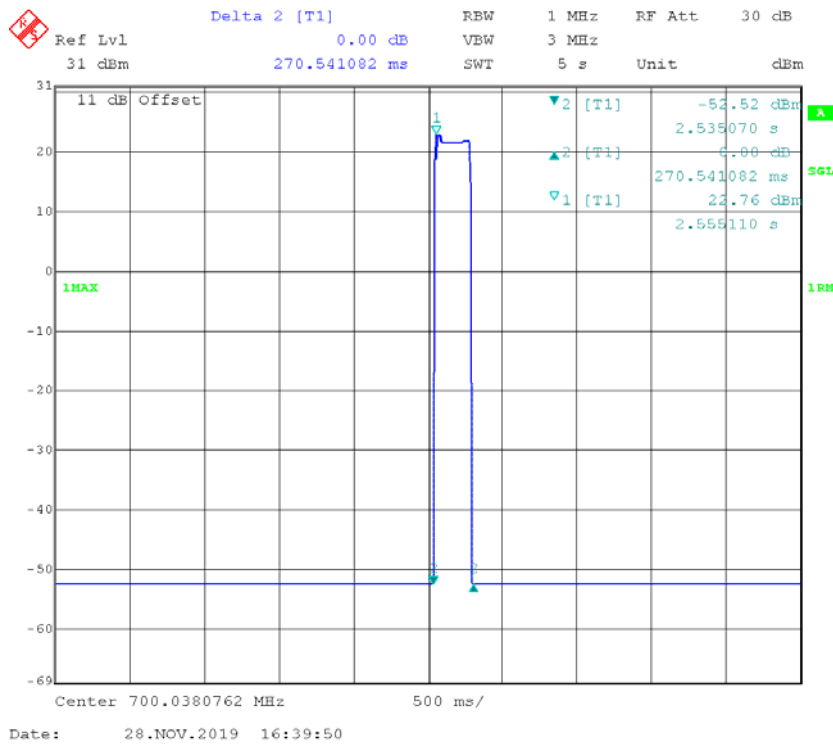

Upper 700MHz Band

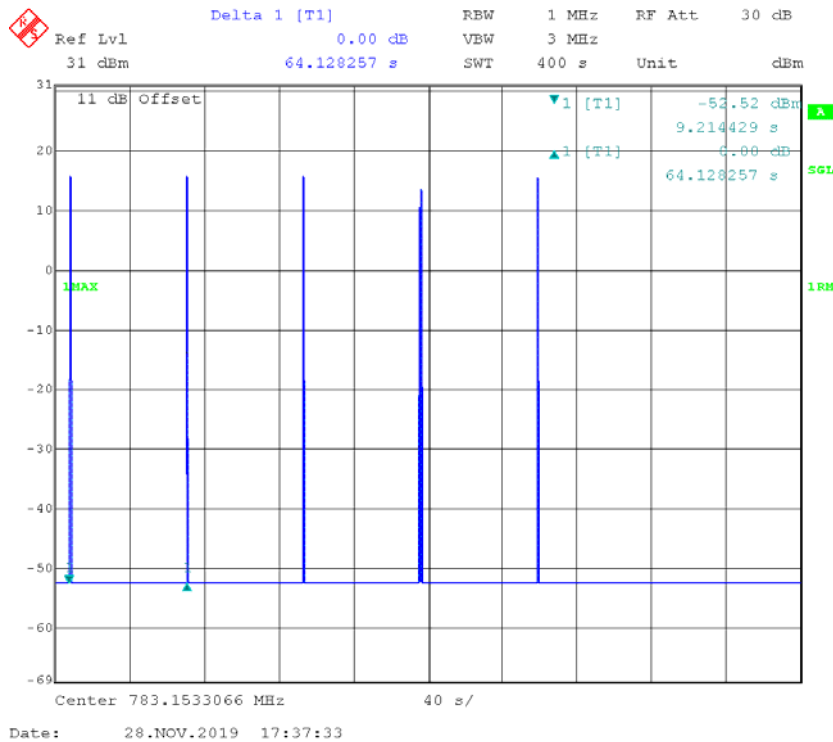
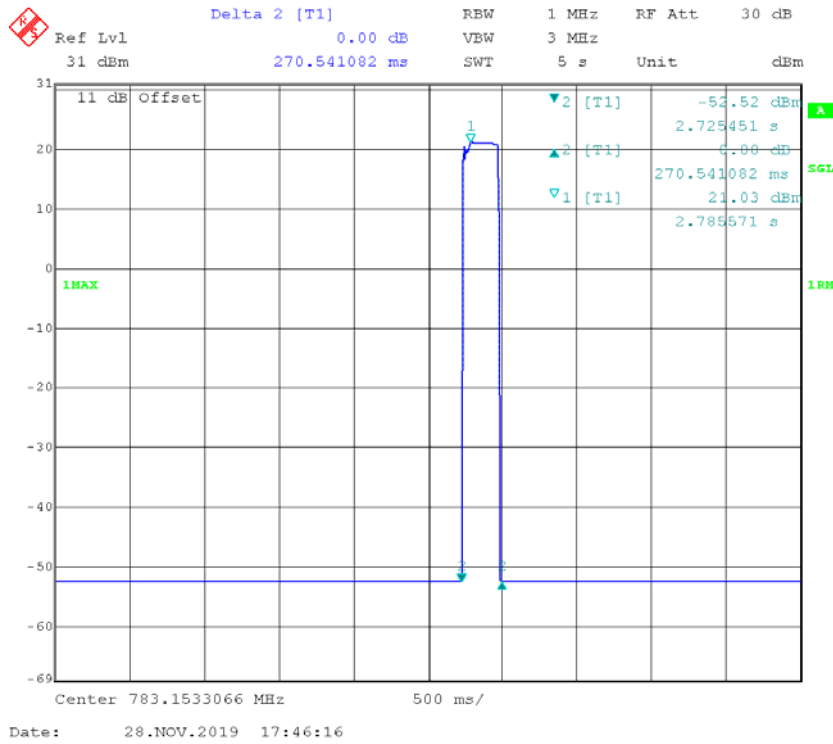

Cellular Band

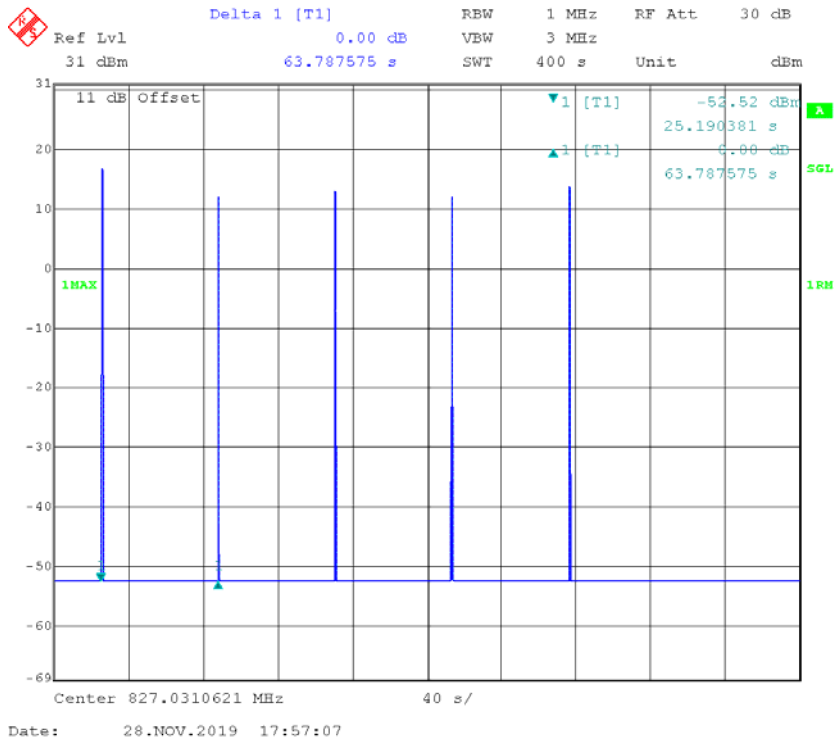
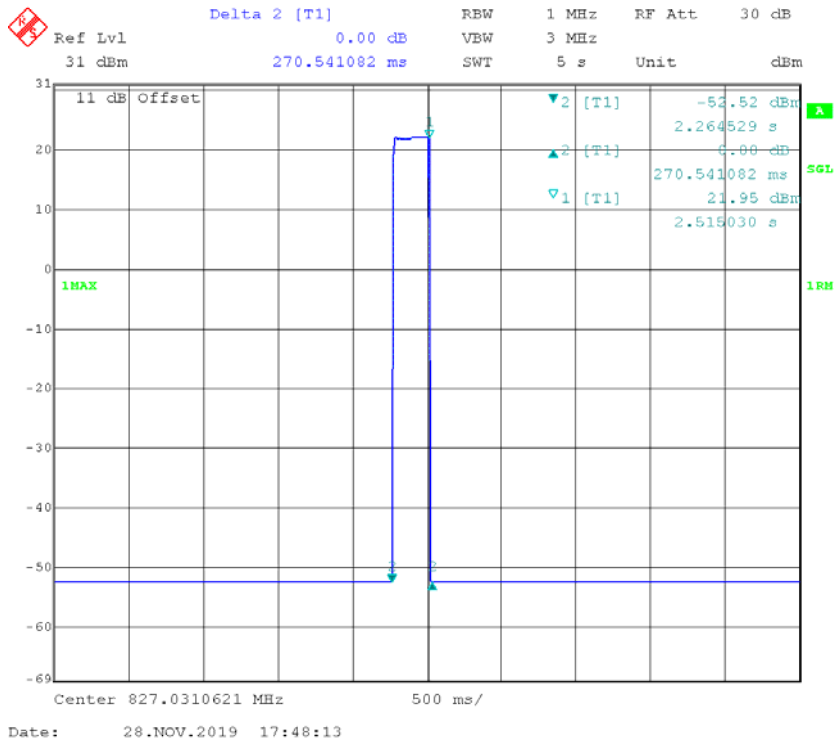

AWS Band

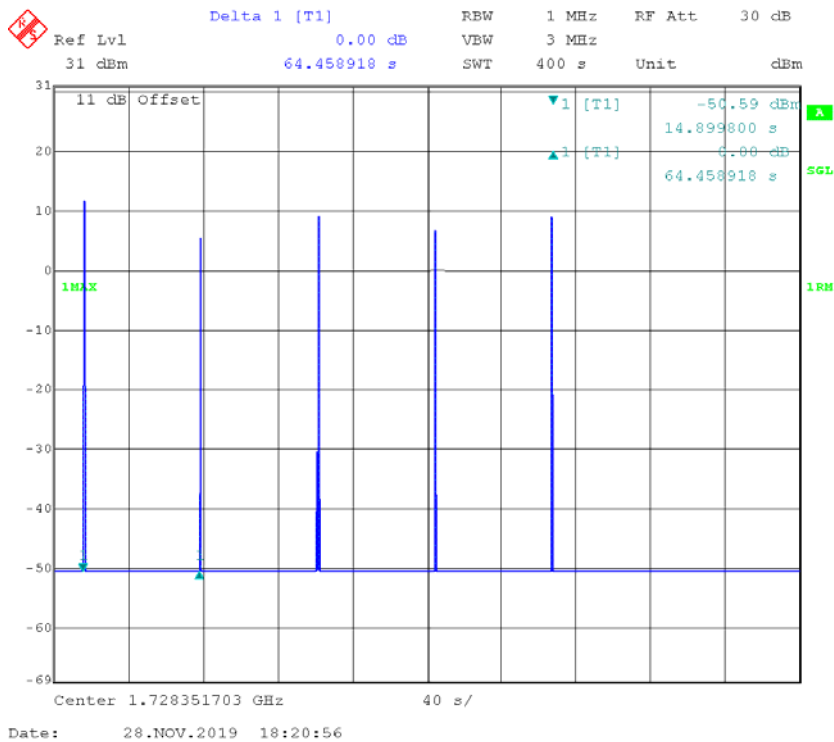
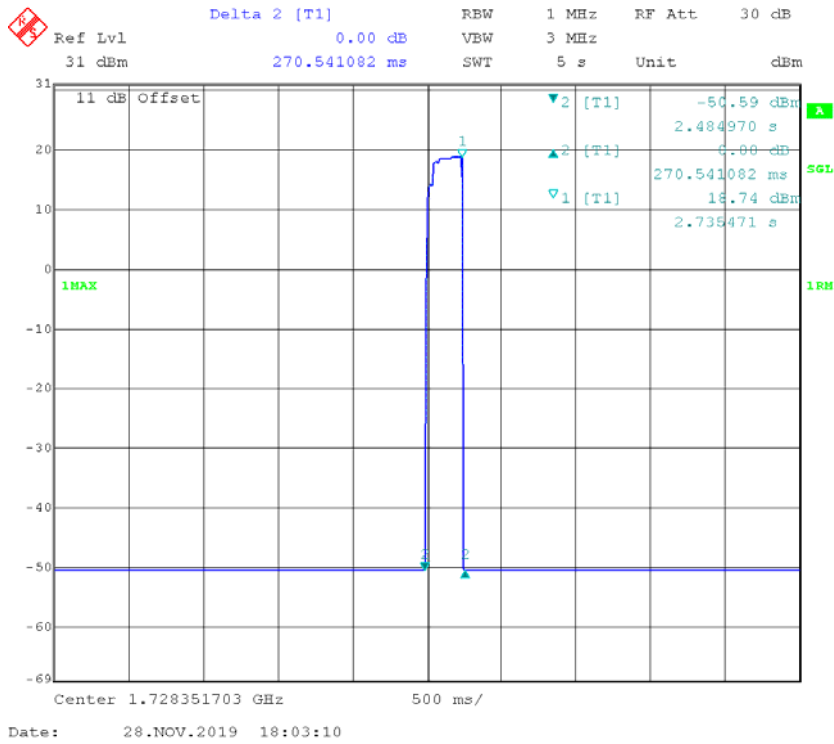

PCS Band

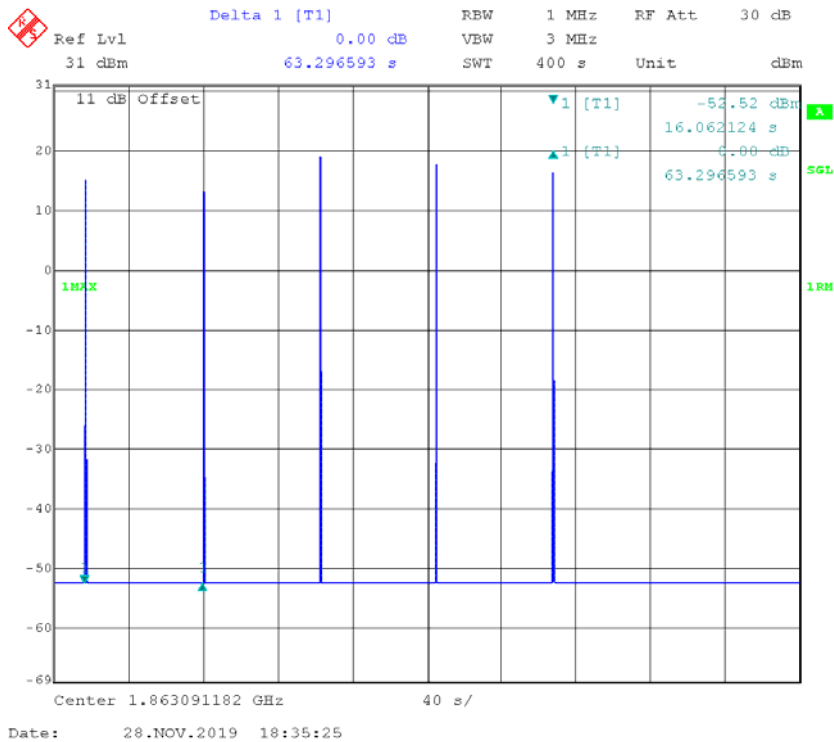
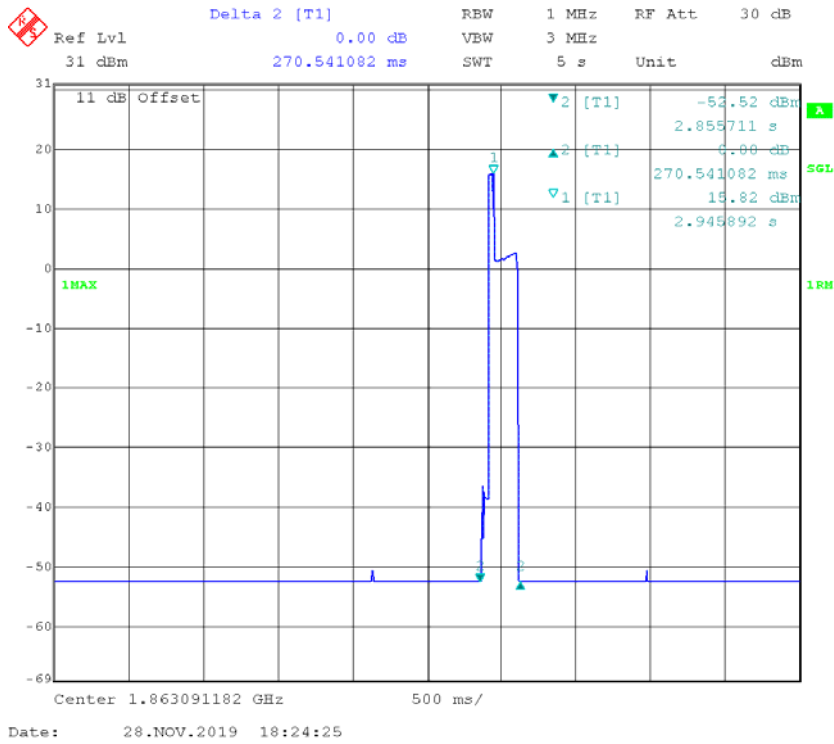

Downlink:

Lower 700MHz Band

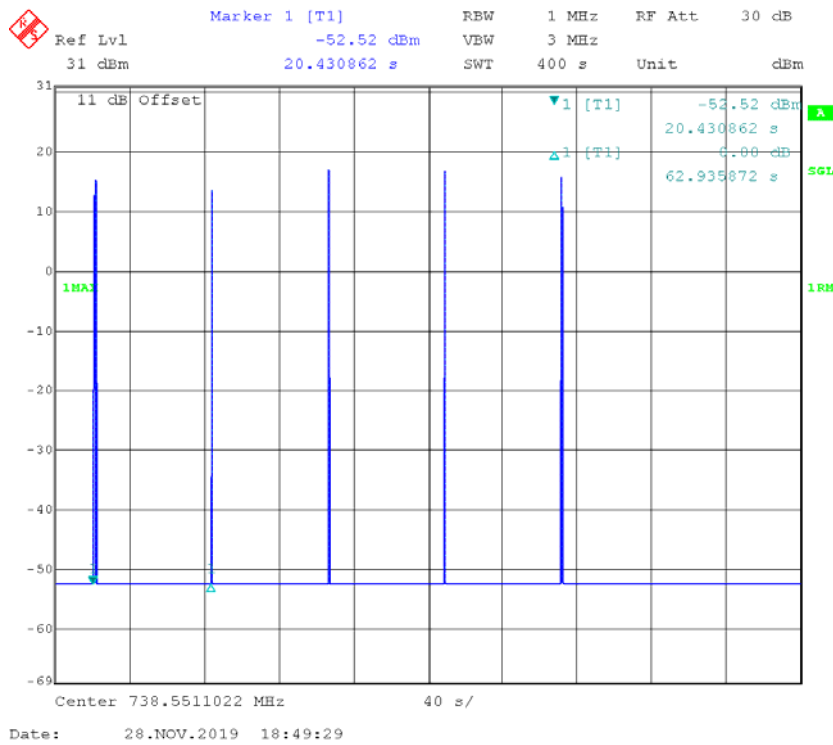
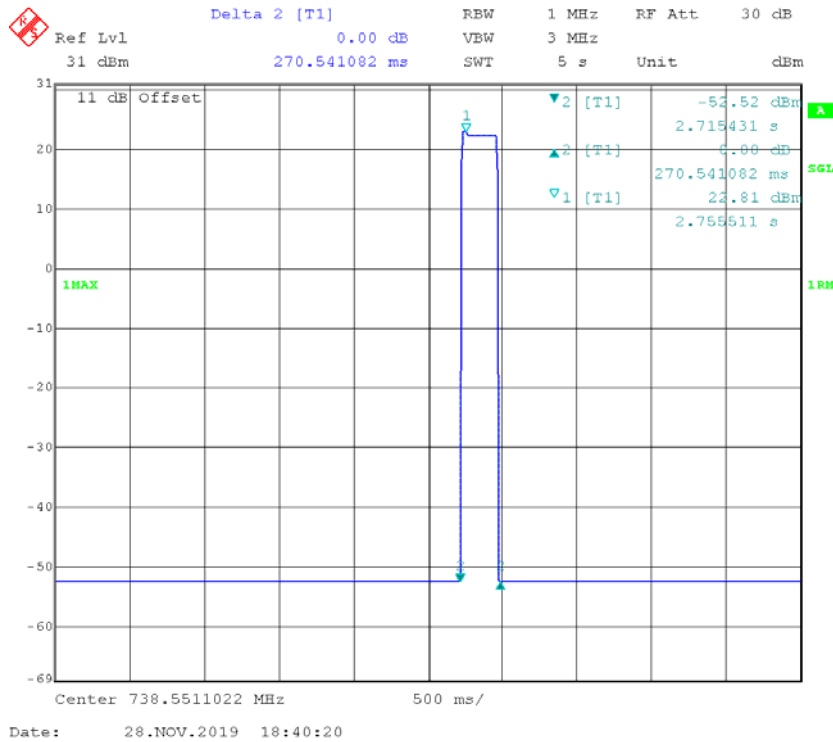

Upper 700MHz Band

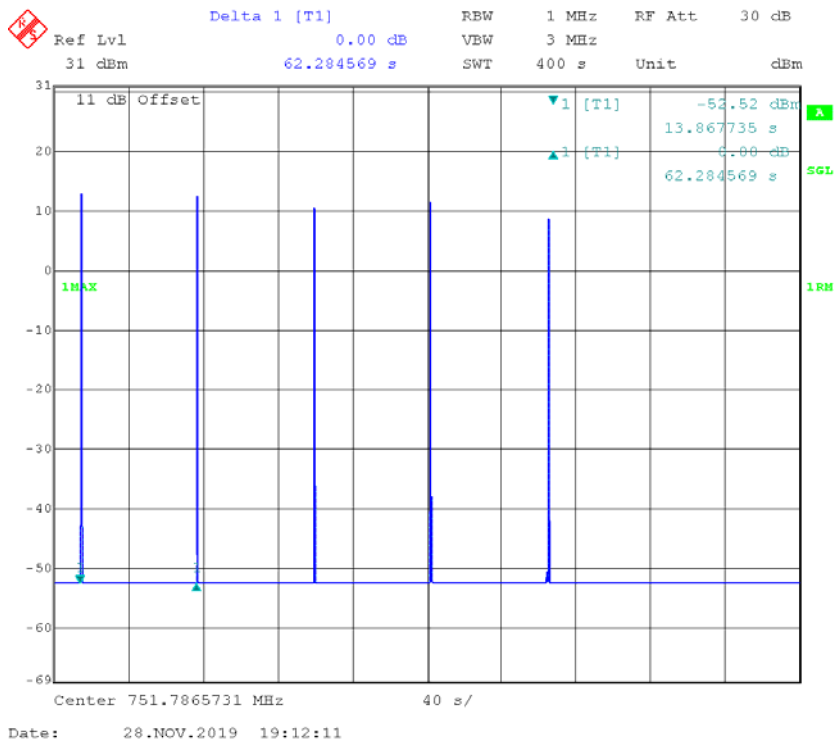
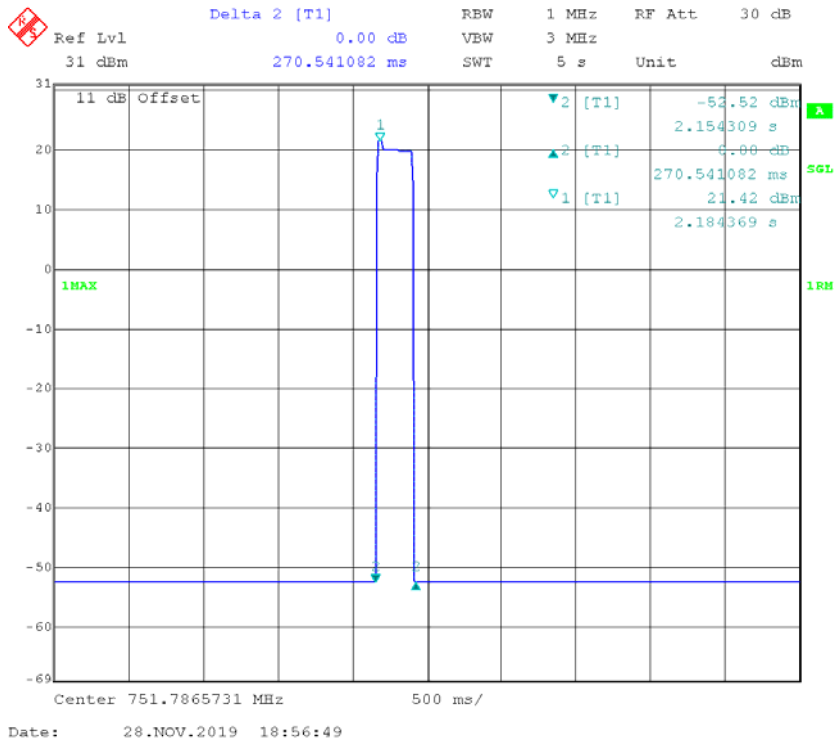

Cellular Band

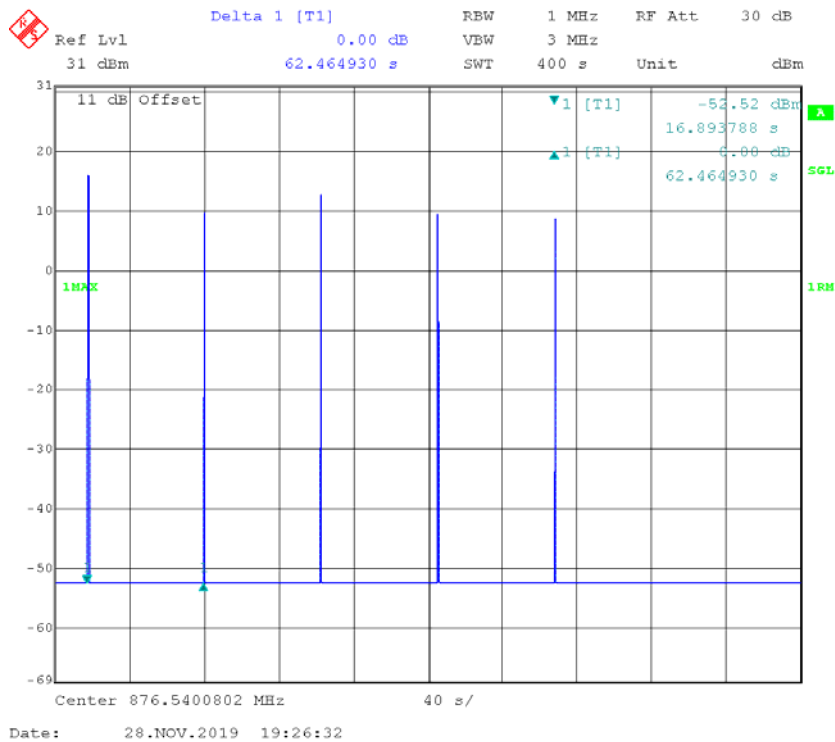
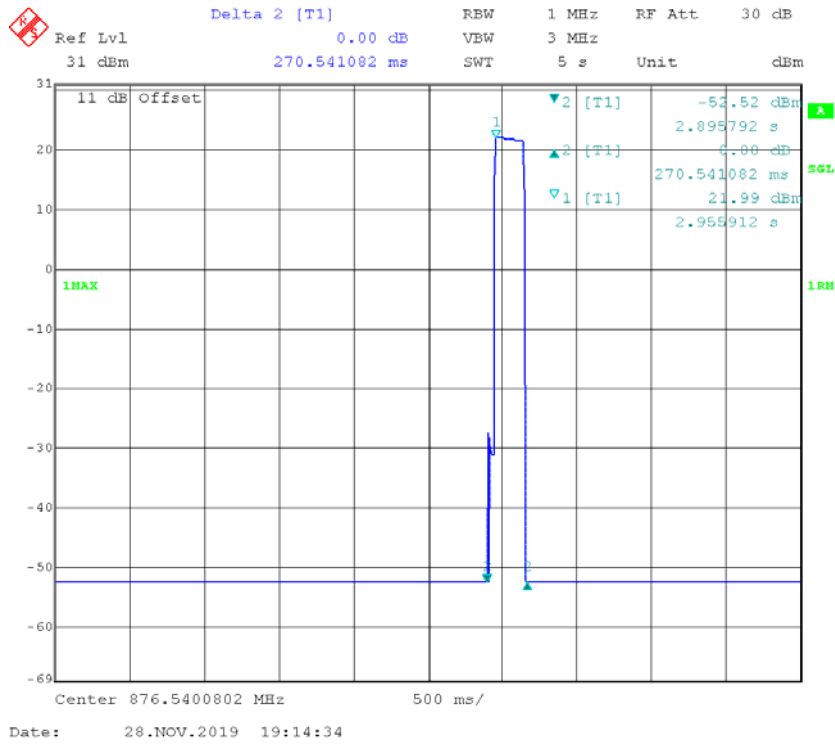

AWS Band

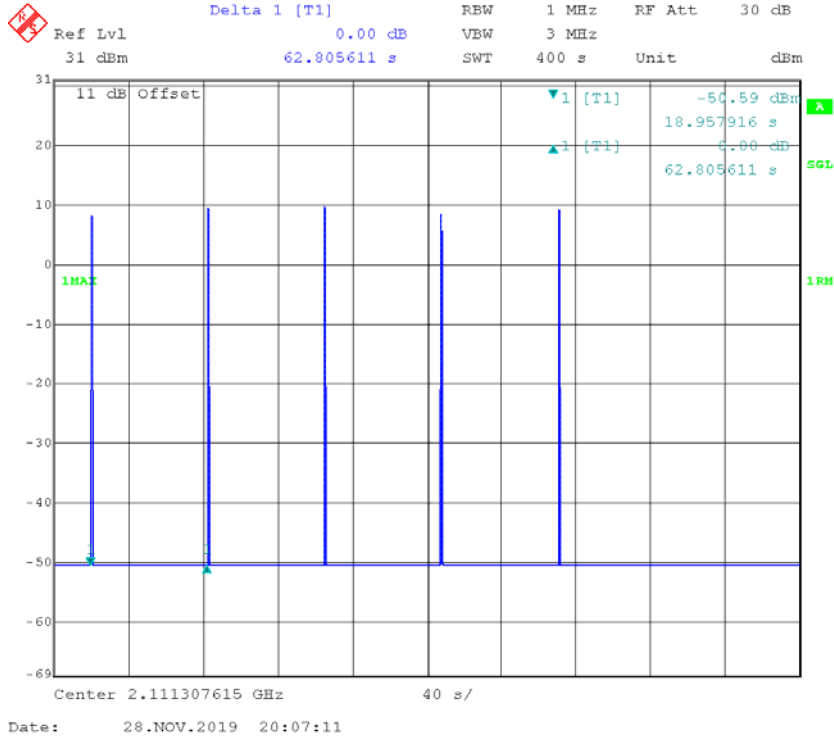
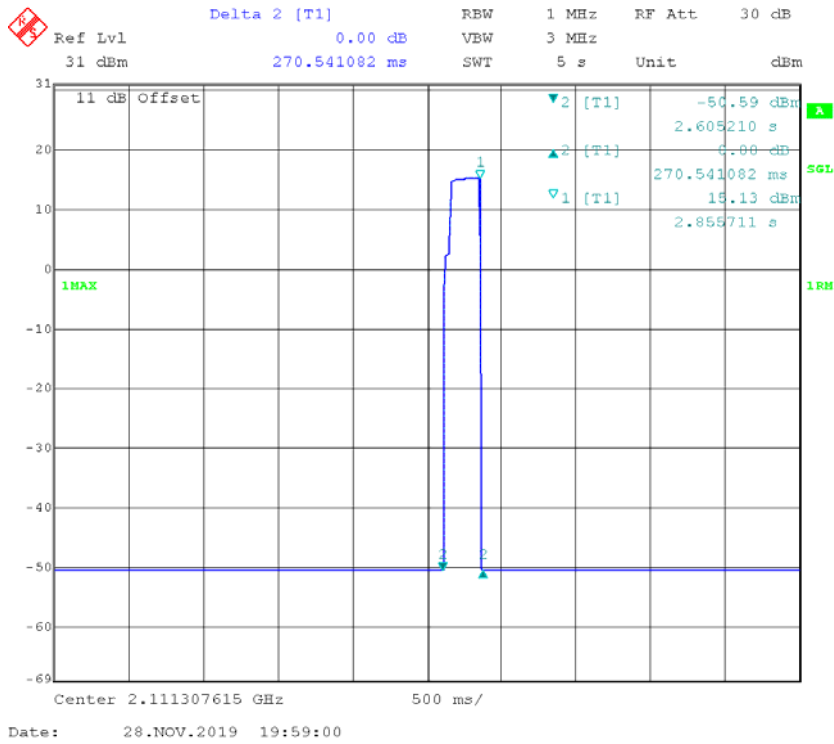

PCS Band

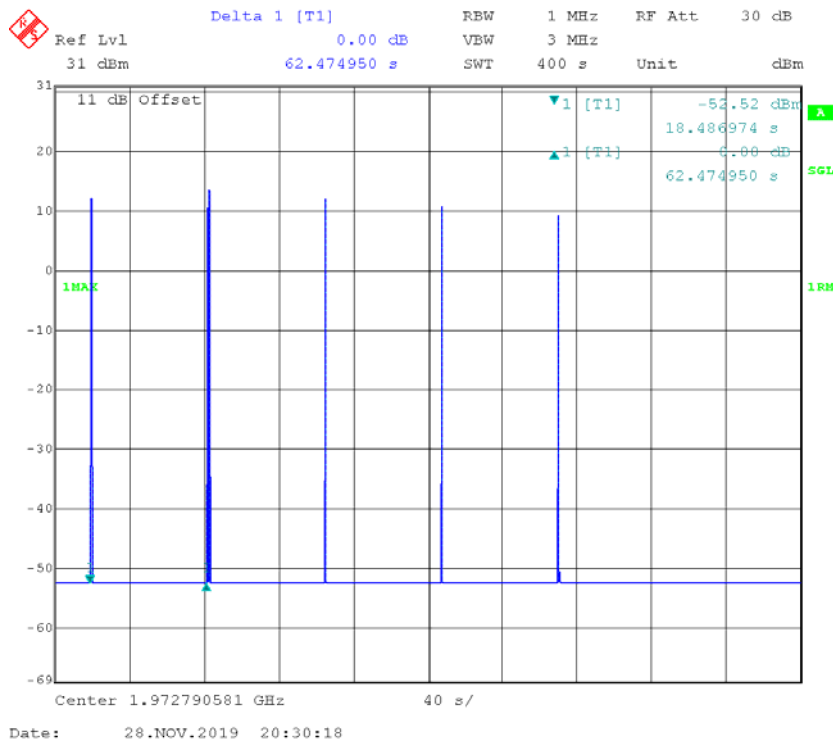
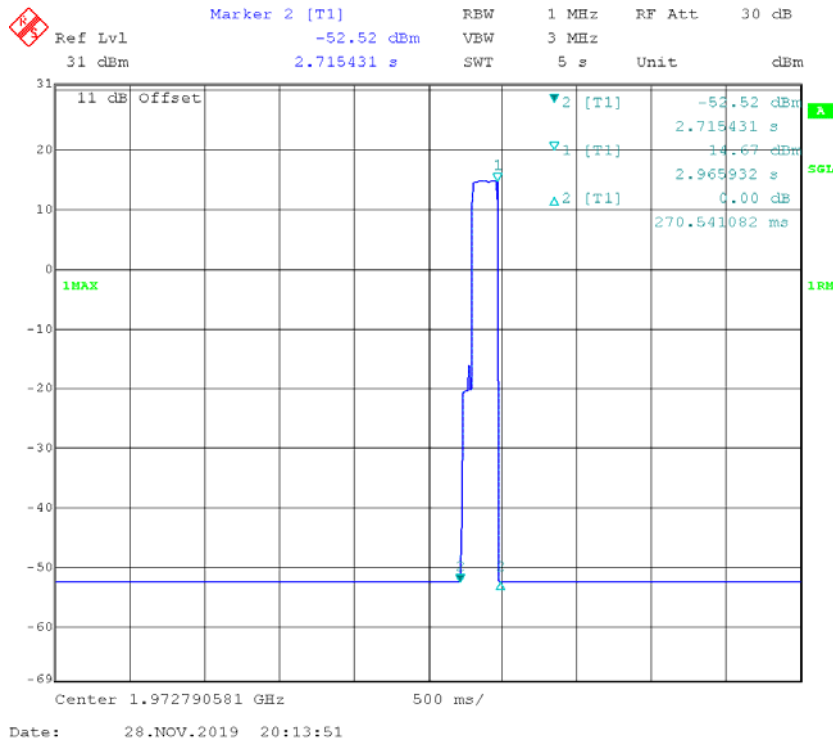

Oscillation Mitigation or Shutdown:

Mode	Operation Band	Max gain dB	Isolation dB	Difference dB	Limit dB	Result
Uplink	PCS	56.97	+5	7.44	12	Compliance
			+4	8.16	12	Compliance
			+3	9.25	12	Compliance
			+2	9.21	12	Compliance
			+1	10.3	12	Compliance
			+0	11.55	12	Compliance
			-1	/	12	Compliance
			-2	/	12	Compliance
			-3	/	12	Compliance
			-4	/	12	Compliance
	-5	/	12	Compliance		
	AWS	55.19	+5	7.5	12	Compliance
			+4	8.09	12	Compliance
			+3	8.92	12	Compliance
			+2	9.93	12	Compliance
			+1	10.84	12	Compliance
			+0	11.36	12	Compliance
			-1	/	12	Compliance
			-2	/	12	Compliance
			-3	/	12	Compliance
			-4	/	12	Compliance
	-5	/	12	Compliance		
	Cellular	56.65	+5	8.75	12	Compliance
			+4	8.66	12	Compliance
			+3	9.6	12	Compliance
			+2	9.78	12	Compliance
			+1	10.8	12	Compliance
			+0	11.34	12	Compliance
			-1	/	12	Compliance
			-2	/	12	Compliance
			-3	/	12	Compliance
			-4	/	12	Compliance
	-5	/	12	Compliance		
	Lower 700	57.97	+5	8.95	12	Compliance
			+4	9.03	12	Compliance
			+3	9.4	12	Compliance
+2			9.8	12	Compliance	
+1			10.86	12	Compliance	
+0			11.72	12	Compliance	
-1			/	12	Compliance	
-2			/	12	Compliance	
-3			/	12	Compliance	
-4			/	12	Compliance	
-5	/	12	Compliance			

Mode	Operation Band	Max gain	Isolation	Difference	Limit	Result
		dB	dB	dB	dB	
Uplink	Upper 700	57.82	+5	8.7	12	Compliance
			+4	9.39	12	Compliance
			+3	9.82	12	Compliance
			+2	10.65	12	Compliance
			+1	10.72	12	Compliance
			+0	11.49	12	Compliance
			-1	/	12	Compliance
			-2	/	12	Compliance
			-3	/	12	Compliance
			-4	/	12	Compliance
Downlink	PCS	53.72	+5	7.32	12	Compliance
			+4	7.33	12	Compliance
			+3	7.97	12	Compliance
			+2	8.50	12	Compliance
			+1	10.05	12	Compliance
			+0	11.23	12	Compliance
			-1	/	12	Compliance
			-2	/	12	Compliance
			-3	/	12	Compliance
			-4	/	12	Compliance
	-5	/	12	Compliance		
	AWS	54.14	+5	6.02	12	Compliance
			+4	6.19	12	Compliance
			+3	6.24	12	Compliance
			+2	6.02	12	Compliance
			+1	6.46	12	Compliance
			+0	6.56	12	Compliance
			-1	/	12	Compliance
			-2	/	12	Compliance
			-3	/	12	Compliance
			-4	/	12	Compliance
	-5	/	12	Compliance		
	Cellular	53.99	+5	8.82	12	Compliance
			+4	8.5	12	Compliance
			+3	8.83	12	Compliance
			+2	9.27	12	Compliance
			+1	10.34	12	Compliance
			+0	11.61	12	Compliance
			-1	/	12	Compliance
			-2	/	12	Compliance
-3			/	12	Compliance	
-4			/	12	Compliance	
-5	/	12	Compliance			

Mode	Operation Band	Max gain	Isolation	Difference	Limit	Result
		dB	dB	dB	dB	
Downlink	Lower 700	56.34	+5	7.87	12	Compliance
			+4	8.79	12	Compliance
			+3	8.82	12	Compliance
			+2	9.8	12	Compliance
			+1	11.1	12	Compliance
			+0	11.2	12	Compliance
			-1	/	12	Compliance*
			-2	/	12	Compliance*
			-3	/	12	Compliance*
			-4	/	12	Compliance*
	Upper 700	56.39	+5	10.05	12	Compliance
			+4	10.2	12	Compliance
			+3	10.18	12	Compliance
			+2	10.85	12	Compliance
			+1	11.28	12	Compliance
			+0	11.75	12	Compliance
			-1	/	12	Compliance
			-2	/	12	Compliance
			-3	/	12	Compliance
			-4	/	12	Compliance
-5	/	12	Compliance			

§2.1051- SPURIOUS EMISSIONS AT ANTENNA TERMINALS

Applicable Standards

FCC §2.1051 *Measurements required: Spurious emissions at antenna terminals.*

§20.21(e)(8)(i)(E): Booster out of band emissions (OOBE) shall be at least 6 dB below the FCC's mobile emission limits for the supported bands of operation. Compliance to OOBE limits will utilize high peak-to-average CMRS signal types.

§22.917 (a) Out of band emissions. The power of any emission outside of the authorized operating frequency ranges must be attenuated below the transmitting power (P) by a factor of at least $43 + 10 \log(P)$ dB.

§24.238 (a) Out of band emissions. The power of any emission outside of the authorized operating frequency ranges must be attenuated below the transmitting power (P) by a factor of at least $43 + 10 \log(P)$ dB.

§27.53: the power of any emission shall be attenuated outside the band below the transmitter power (P) by at least $43 + 10 \log(P)$ dB;

Test Procedure

The following procedures shall be used to demonstrate compliance to the applicable conducted spurious emissions limits as per § 2.1051.

Note: *For frequencies below 1 GHz, an RBW of 1 MHz may be used in a preliminary measurement. If non-compliant emissions are detected, a final measurement shall be made with a 100 kHz RBW. Additionally, a peak detector may also be used for the preliminary measurement. If non-compliant emissions are detected then a final measurement of these emissions shall be made with the power averaging (RMS) detector.*

- a) Connect the EUT to the test equipment as shown in **Figure 1**. Begin with the uplink output connected to the spectrum analyzer.
- b) Configure the signal generator for AWGN with a 99% occupied bandwidth of 4.1 MHz with a center frequency corresponding to the center of the CMRS band under test.
- c) Set the signal generator amplitude to the level determined in the power measurement procedure in 7.2.
- d) Turn on the signal generator RF output and measure the spurious emission power levels with an appropriate measurement instrument as follows.
 - 1) Set RBW = measurement bandwidth specified in the applicable rule section for the operational frequency band under consideration (see Annex A for relevant cross-references). Note that many of the individual rule sections permit the use of a narrower RBW (typically $\geq 1\%$ of the emission bandwidth) to enhance measurement accuracy, but the result must then be integrated over the specified measurement bandwidth.
 - 2) Set VBW = $3 \times$ RBW.
 - 3) Select the power averaging (RMS) detector. (See above note regarding the use of a peak detector for preliminary measurements.)
 - 4) Sweep time = auto-couple.
 - 5) Set the analyzer start frequency to the lowest radio frequency signal generated in the equipment, without going below 9 kHz, and the stop frequency to the lower band/block edge frequency minus 100 kHz or 1 MHz, as specified in the applicable rule part. Note that the number of measurement points in each sweep

must be $\geq (2 \times \text{span/RBW})$ which may require that the measurement range defined by the start and stop frequencies above be subdivided, depending on the available number of measurement points provided by the spectrum analyzer. Trace average at least 10 traces in power averaging (i.e., RMS) mode.

6) Use the peak marker function to identify the highest amplitude level over each measured frequency range. Record the frequency and amplitude and capture a plot for inclusion in the test report.

7) Reset the analyzer start frequency to the upper band/block edge frequency plus 100 kHz or 1 MHz, as specified in the applicable rule part, and the analyzer stop frequency to $10 \times$ the highest frequency of the fundamental emission. Note that the number of measurement points in each sweep must be $\geq (2 \times \text{span/RBW})$ which may require that the measurement range defined by the start and stop frequencies above be subdivided, depending on the available number of measurement points provided by the spectrum analyzer.

8) Use the peak marker function to identify the highest amplitude level over each of the measured frequency ranges. Record the frequency and amplitude and capture a plot for inclusion in the test report.

e) Repeat 7.6b) through 7.6d) for each supported frequency band of operation.

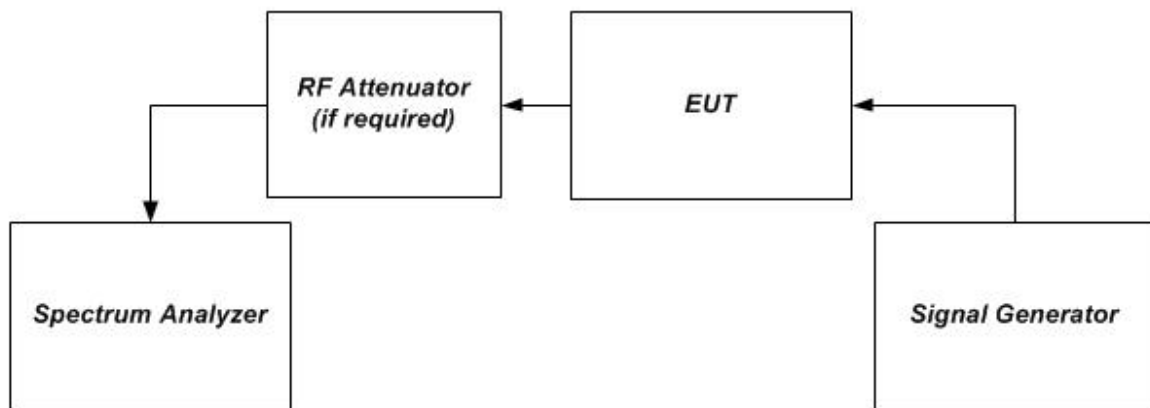

Figure 1 – Band verification test instrumentation setup

Test Data

Environmental Conditions

Temperature:	25.9°C
Relative Humidity:	42 %
ATM Pressure:	101.2 kPa

The testing was performed by Blake Yang on 2019-11-27.

Test Mode: Transmitting, please refer to the following plots.

Test Result: Compliance.

Uplink:

Lower 700MHz Band

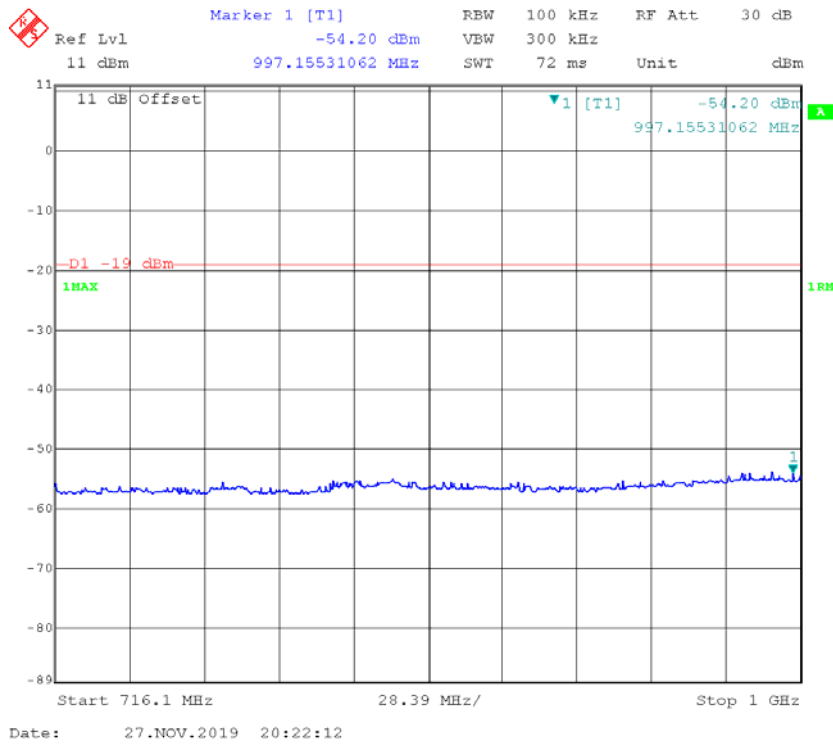
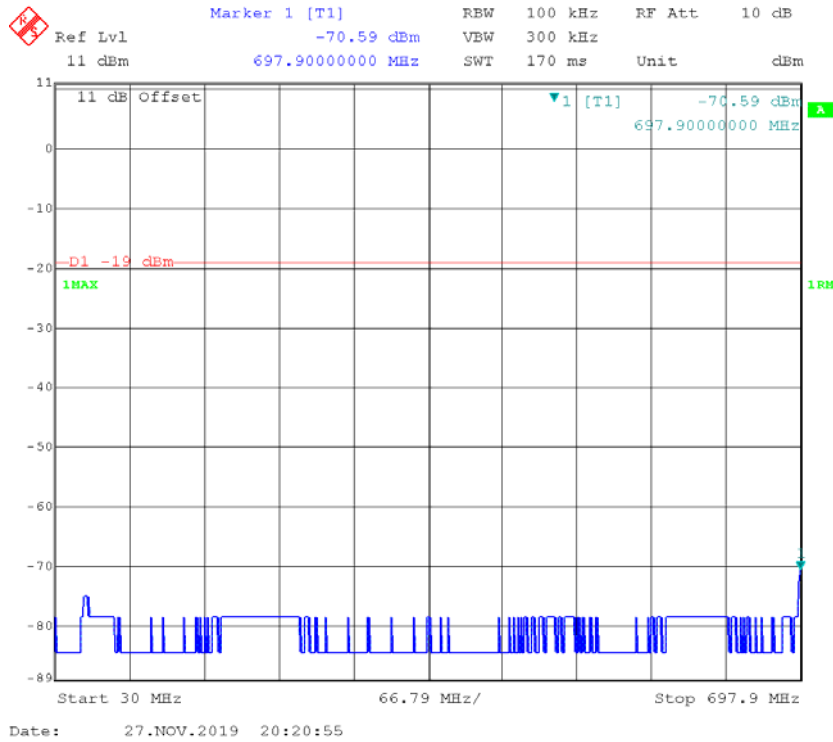

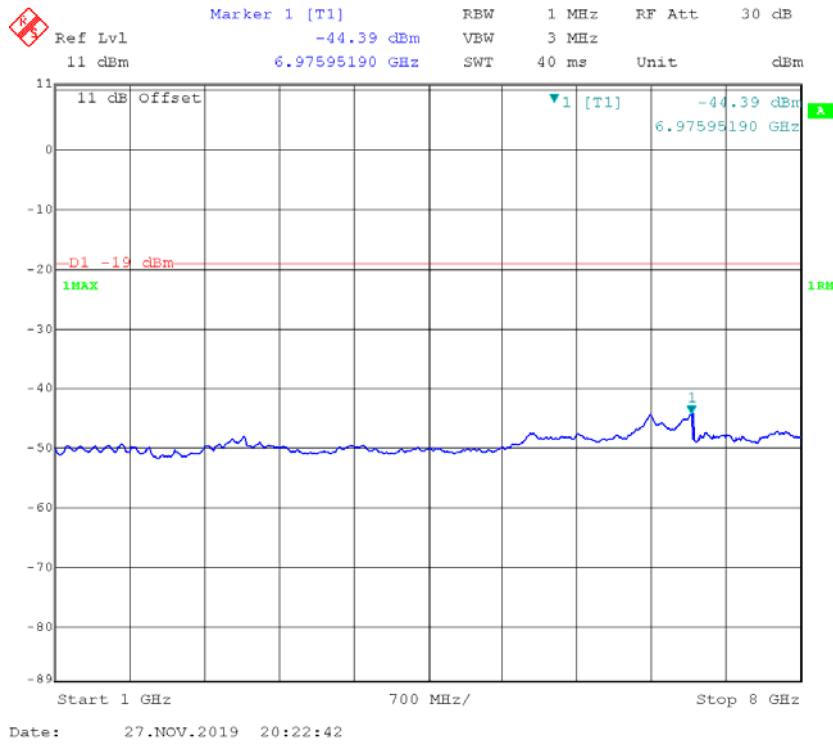

Upper 700MHz Band

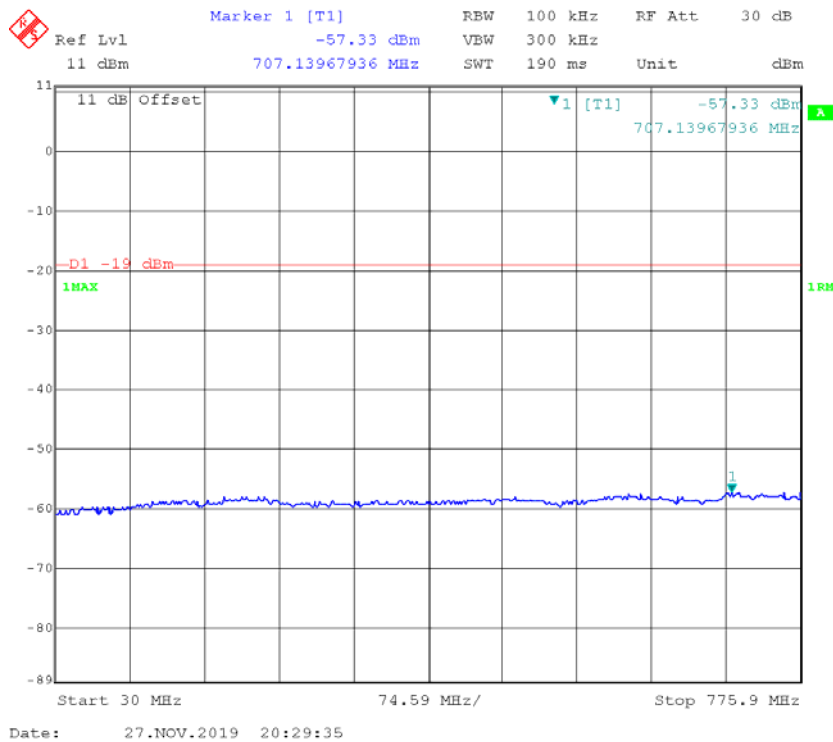

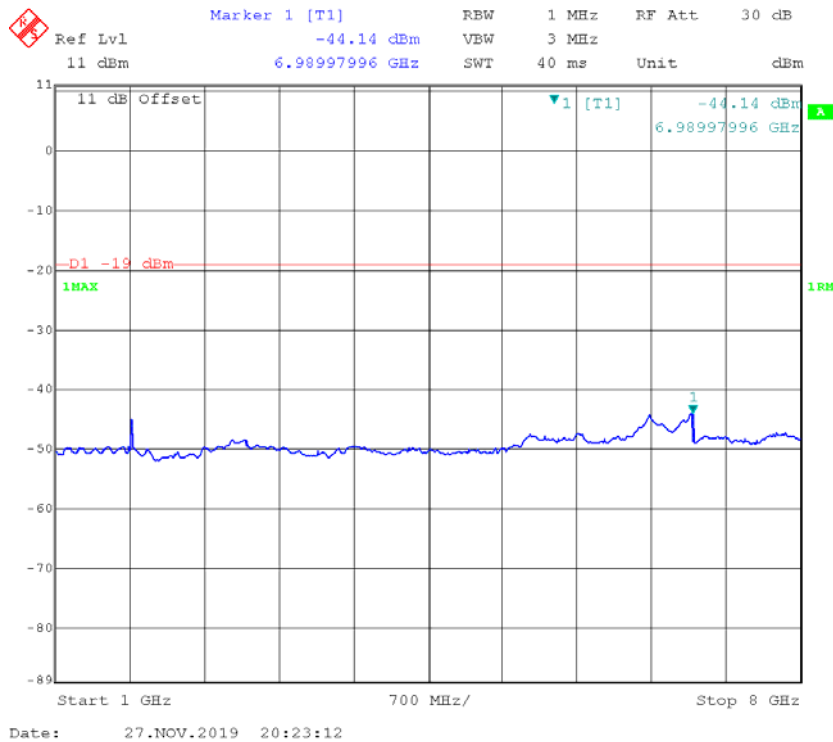
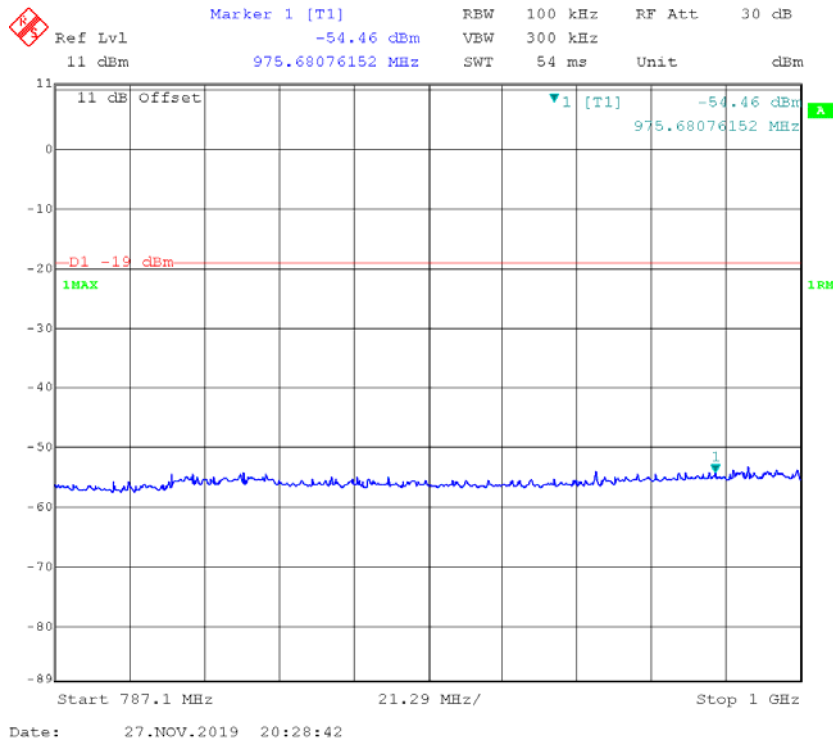

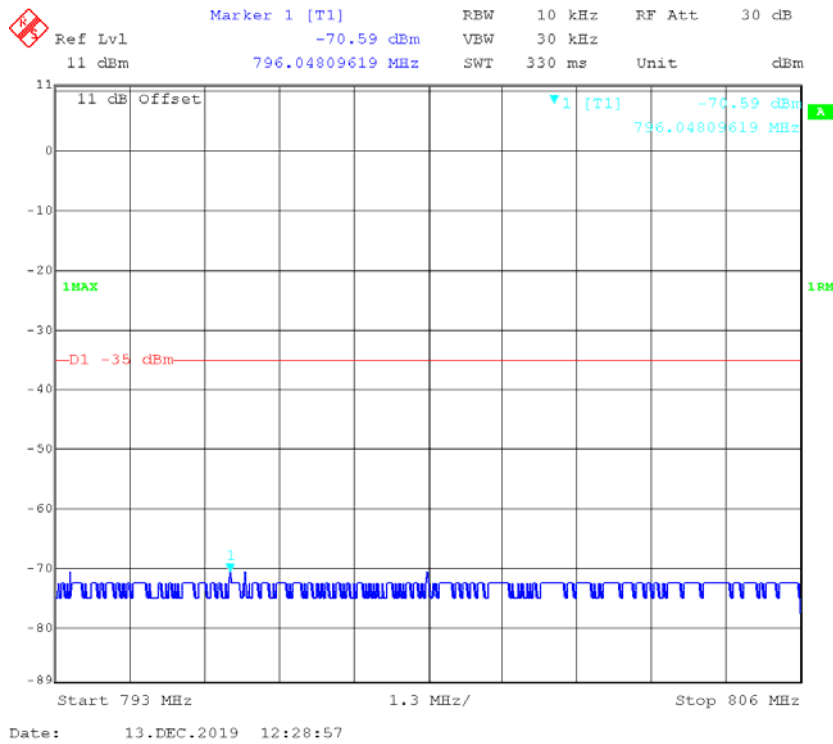
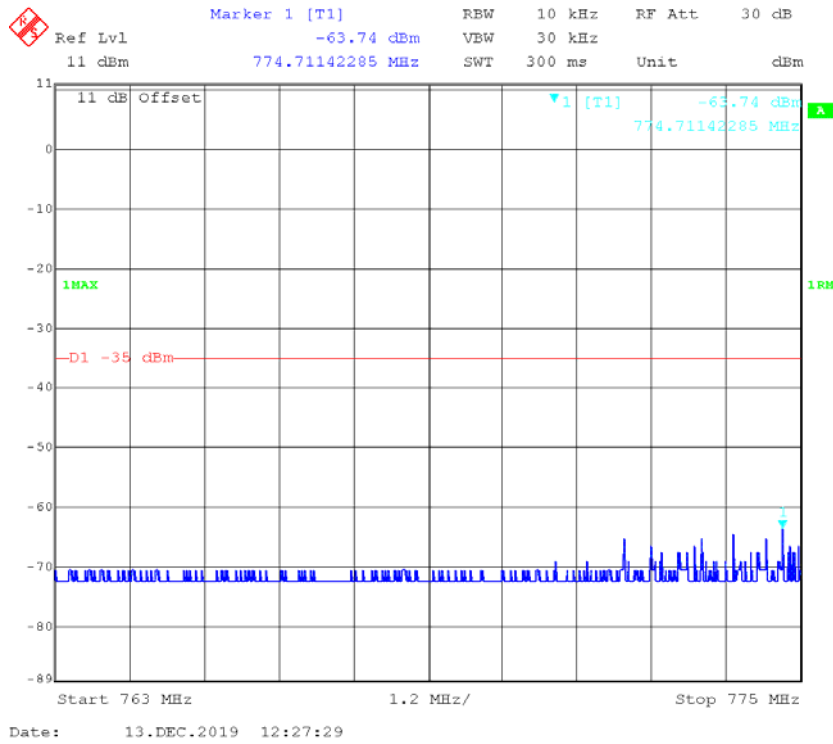

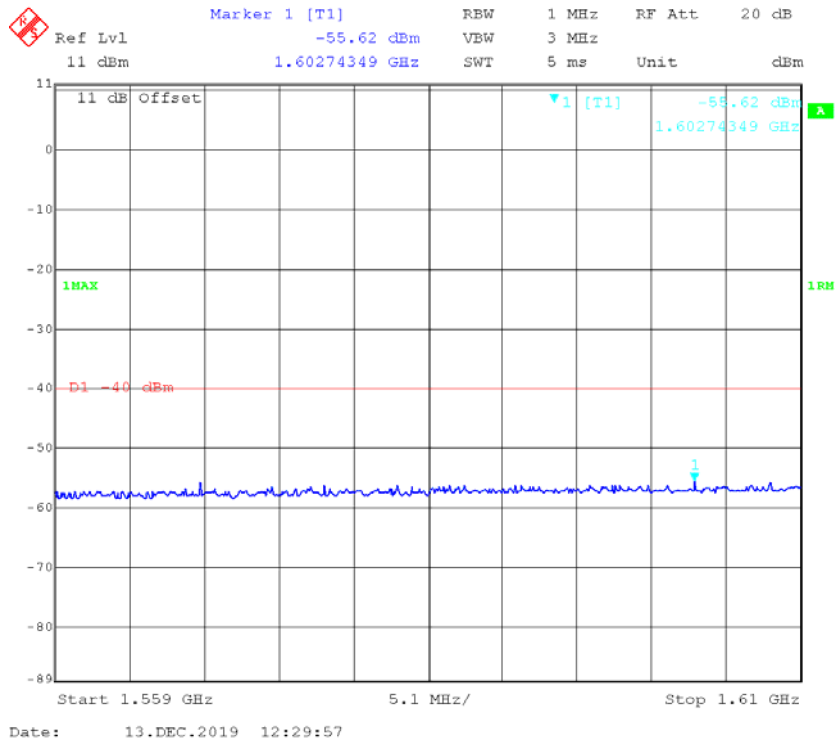

Cellular Band

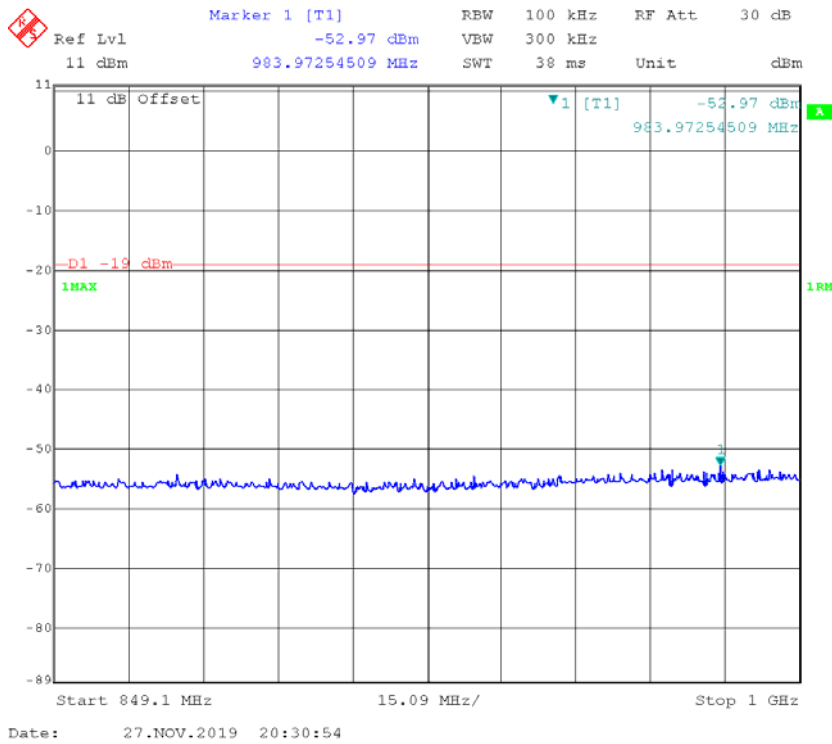
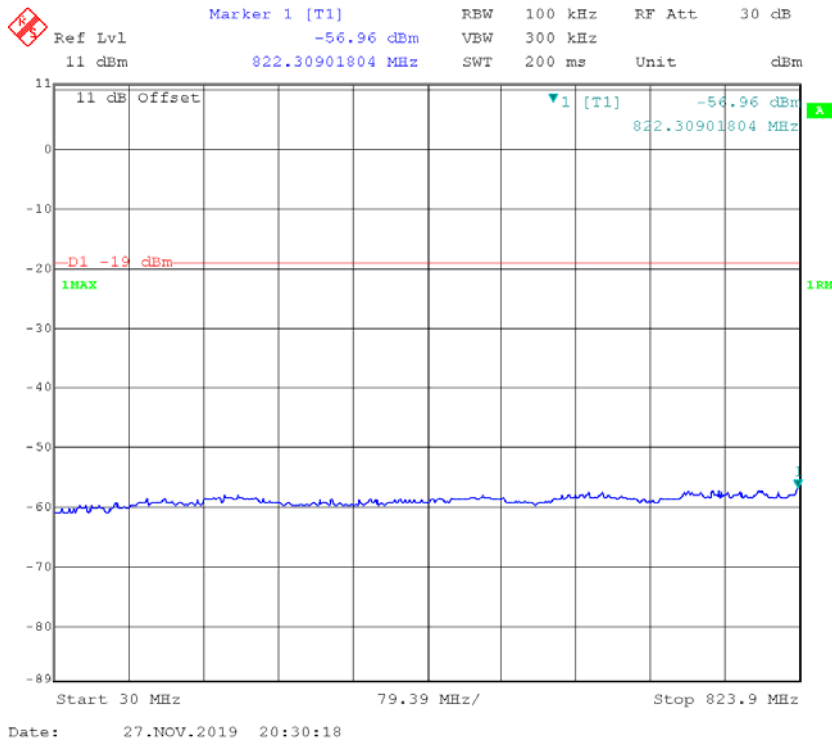

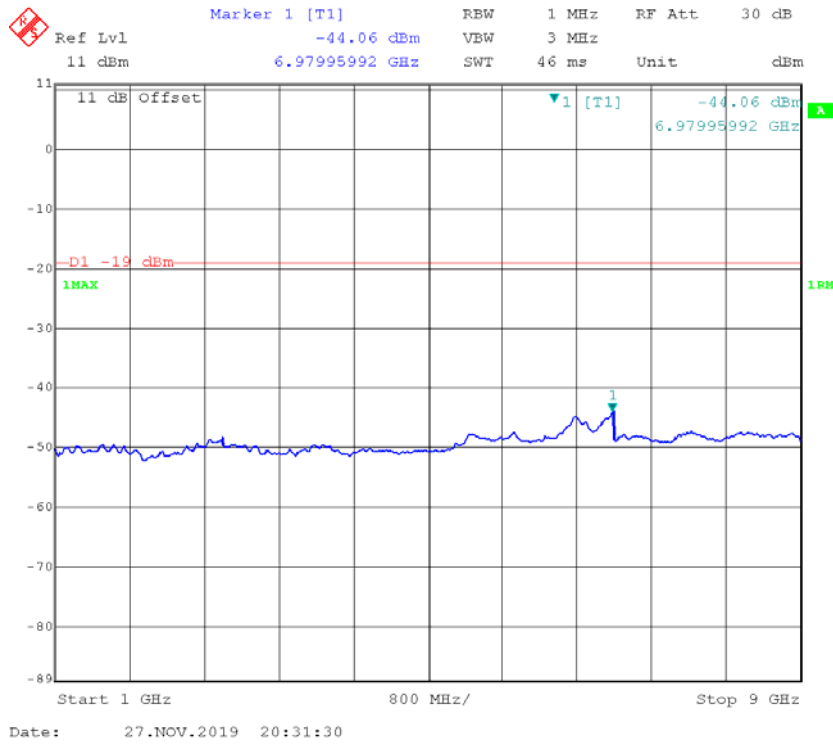

AWS Band

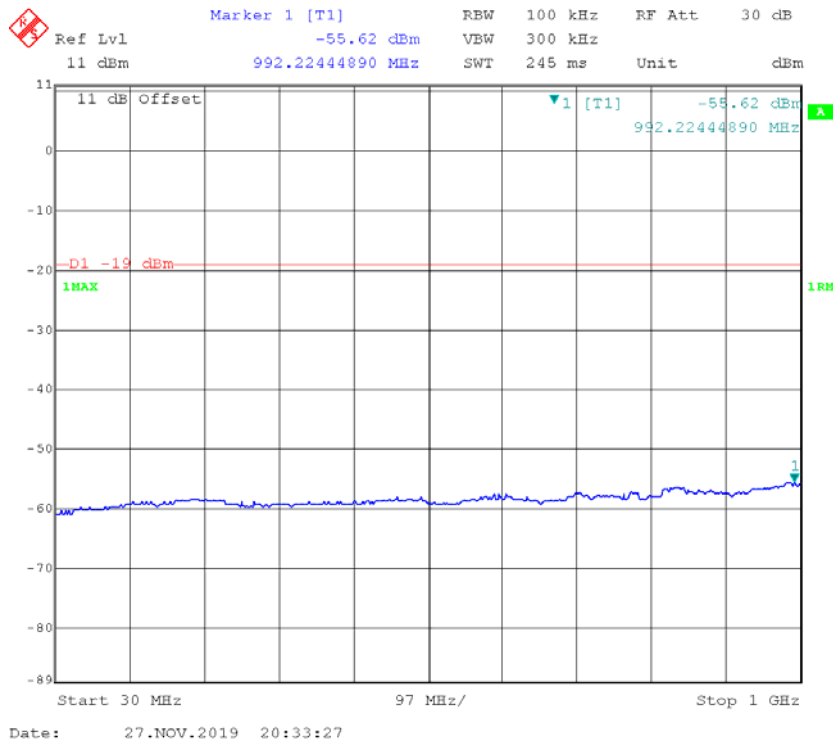

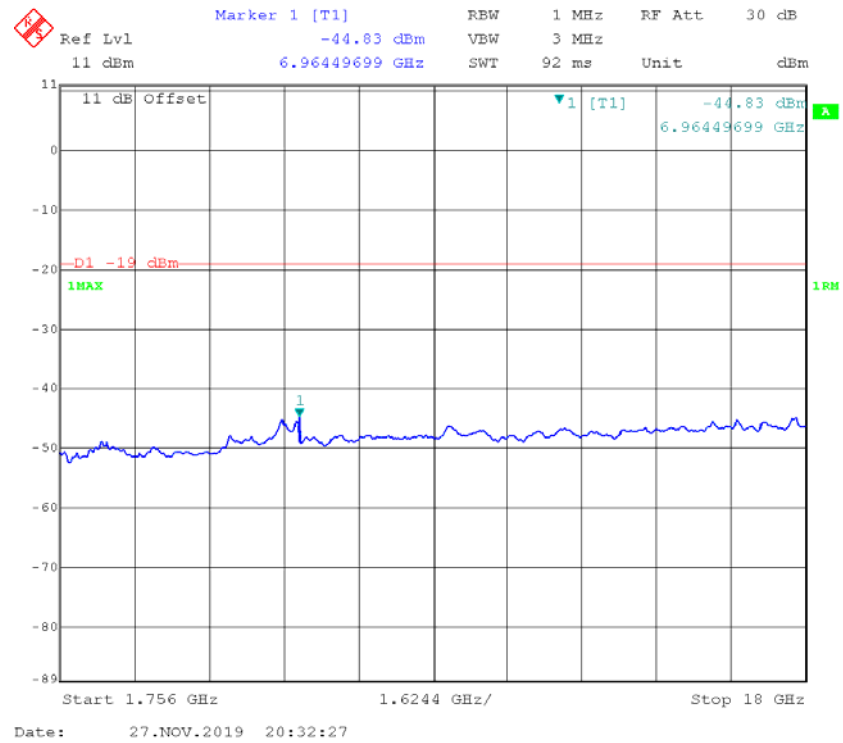
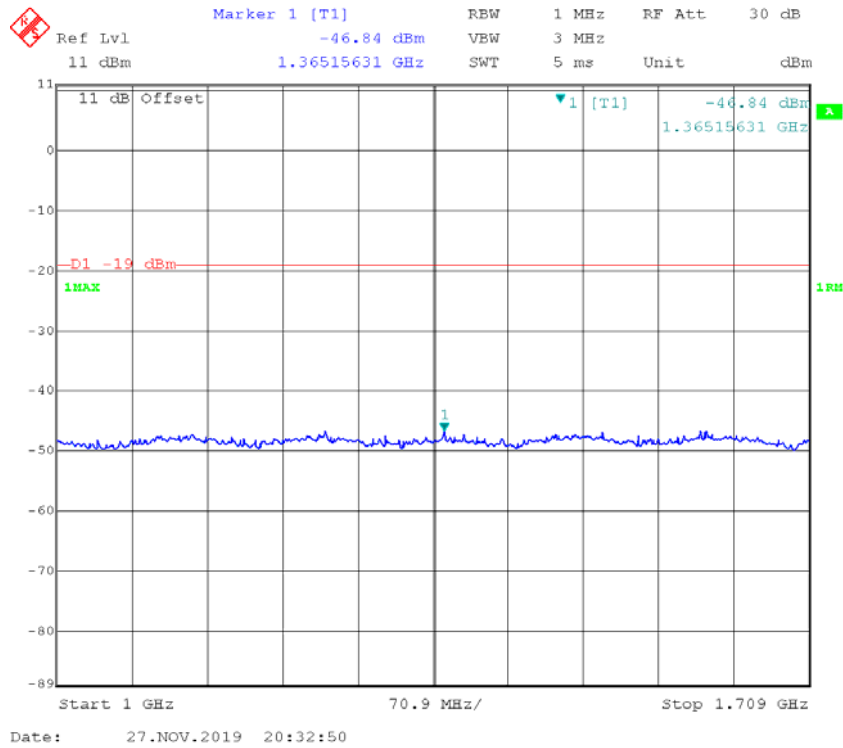

PCS Band

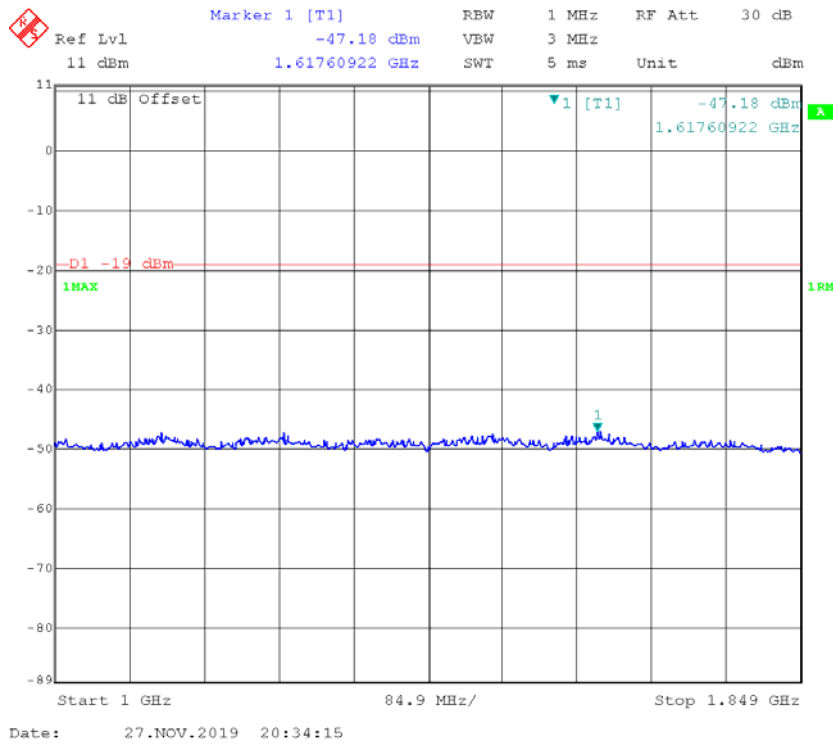
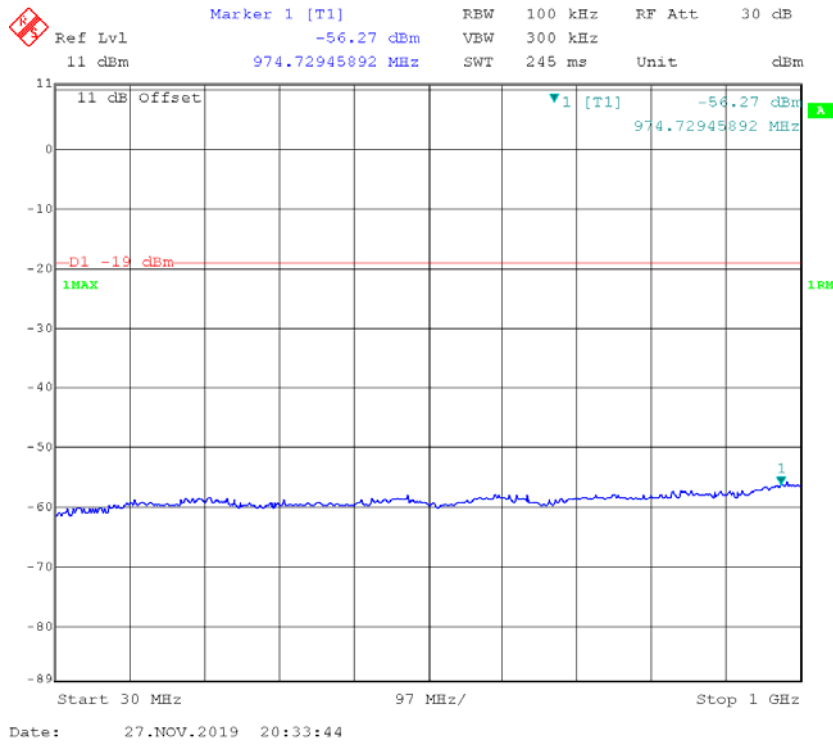

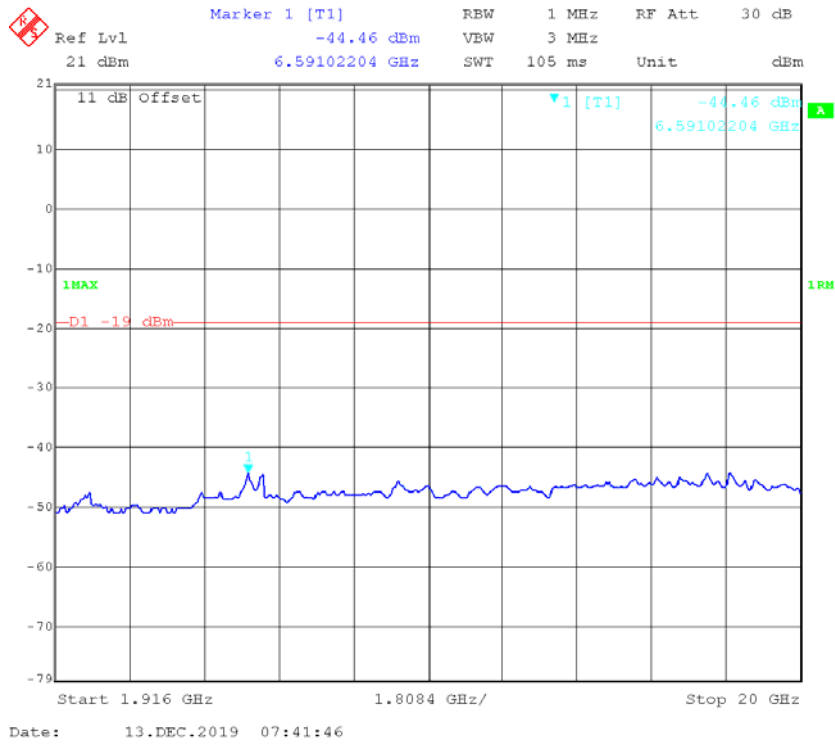

Downlink:

Lower 700MHz Band

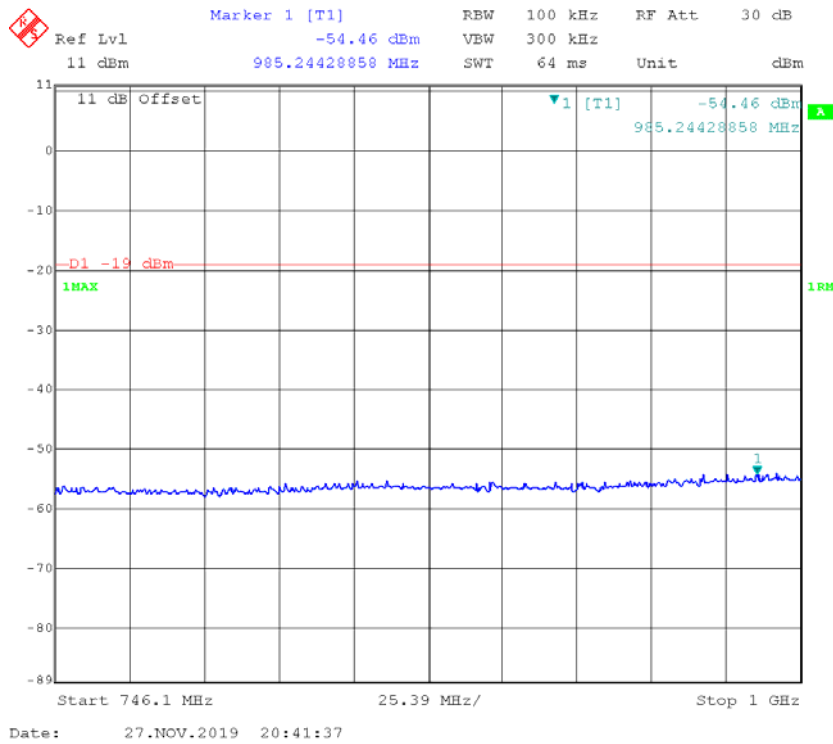
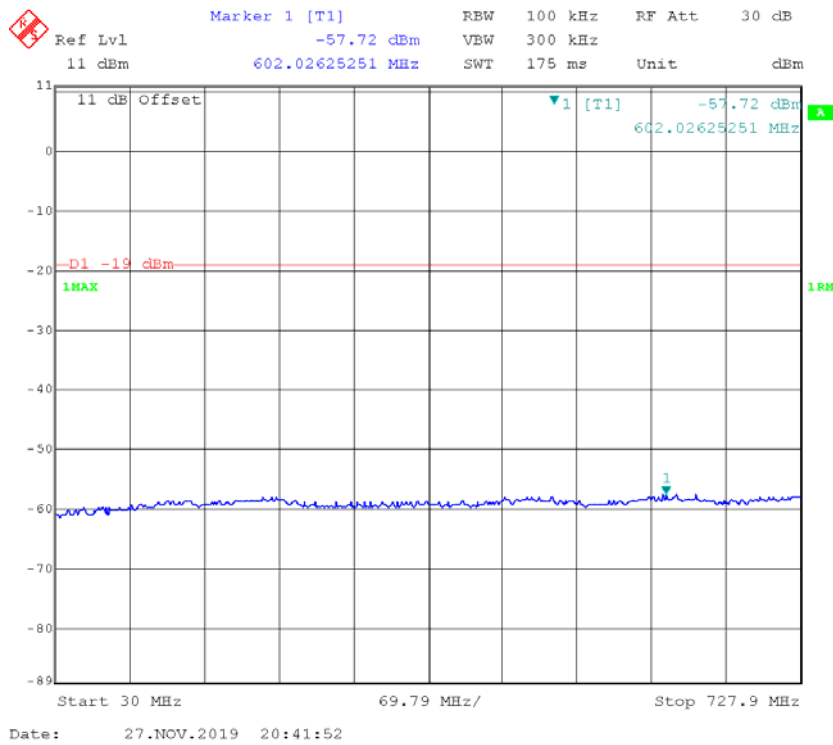

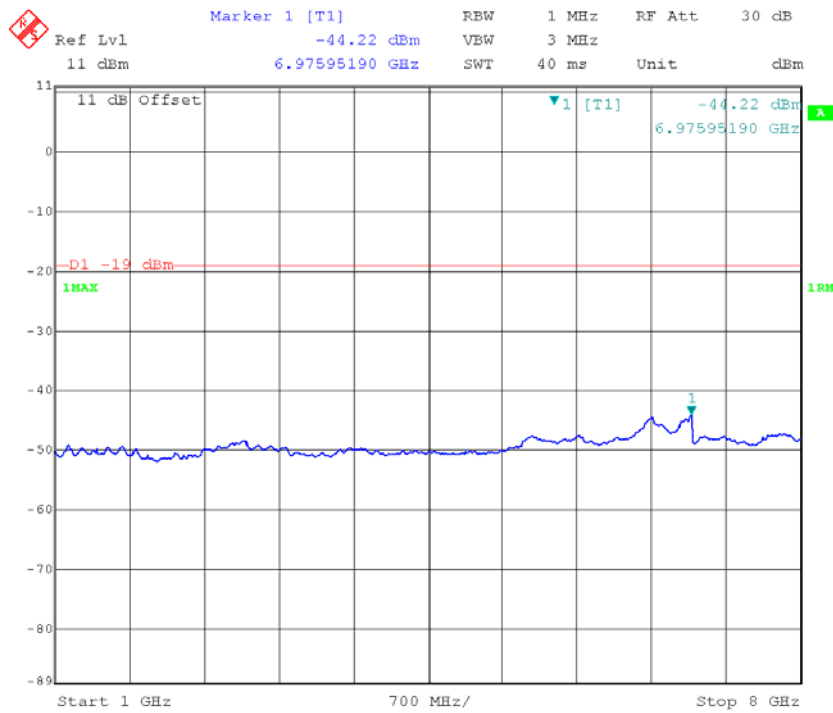

Date: 27.NOV.2019 20:42:23

Upper 700MHz Band

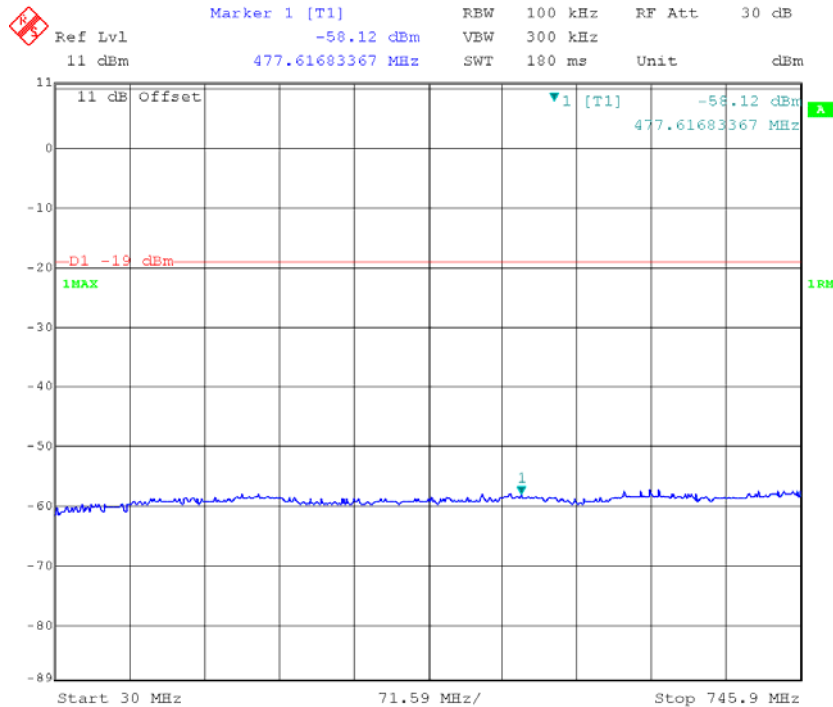

Date: 27.NOV.2019 20:42:06

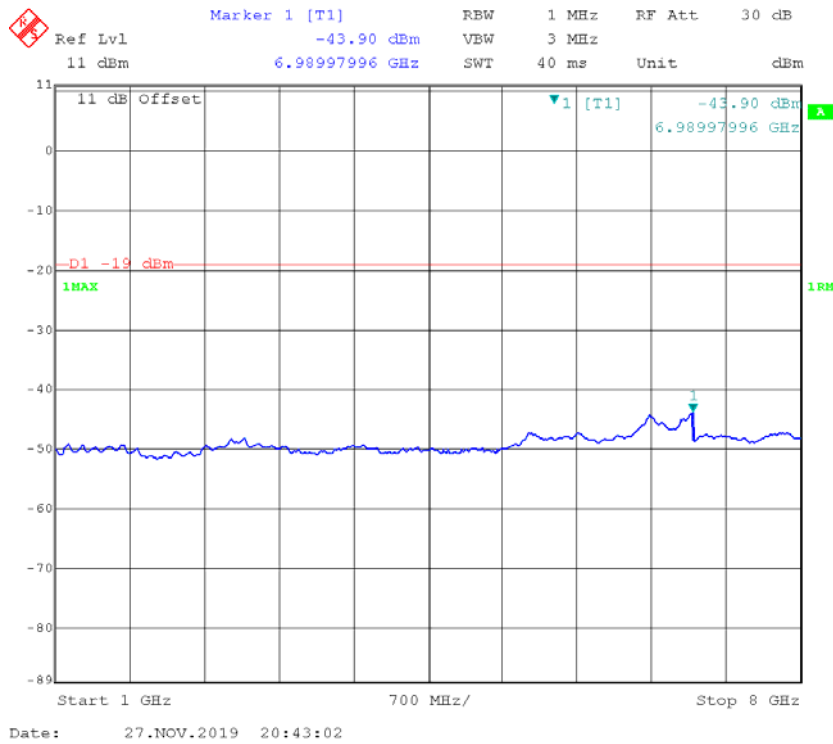
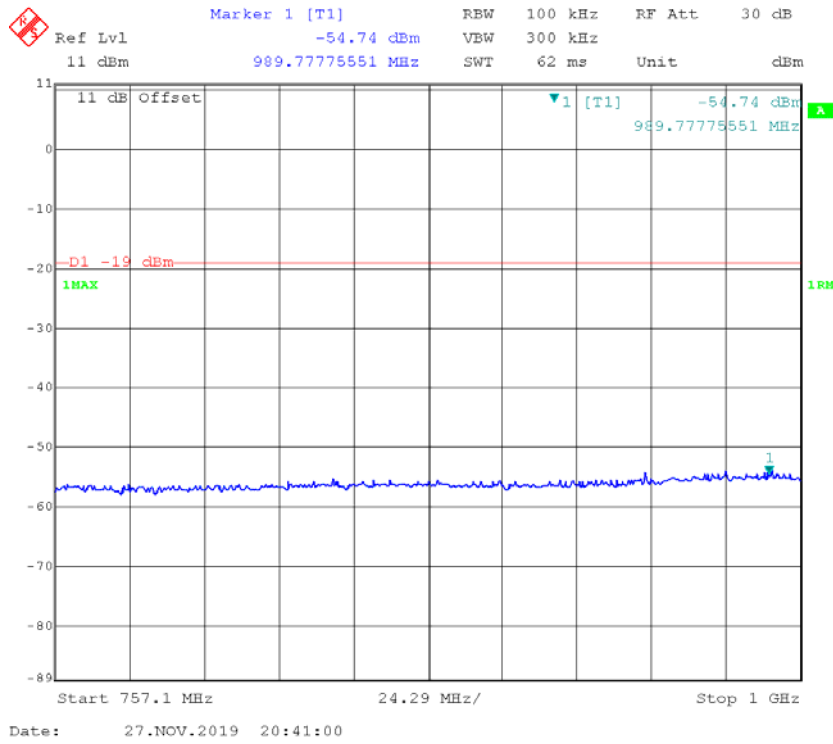

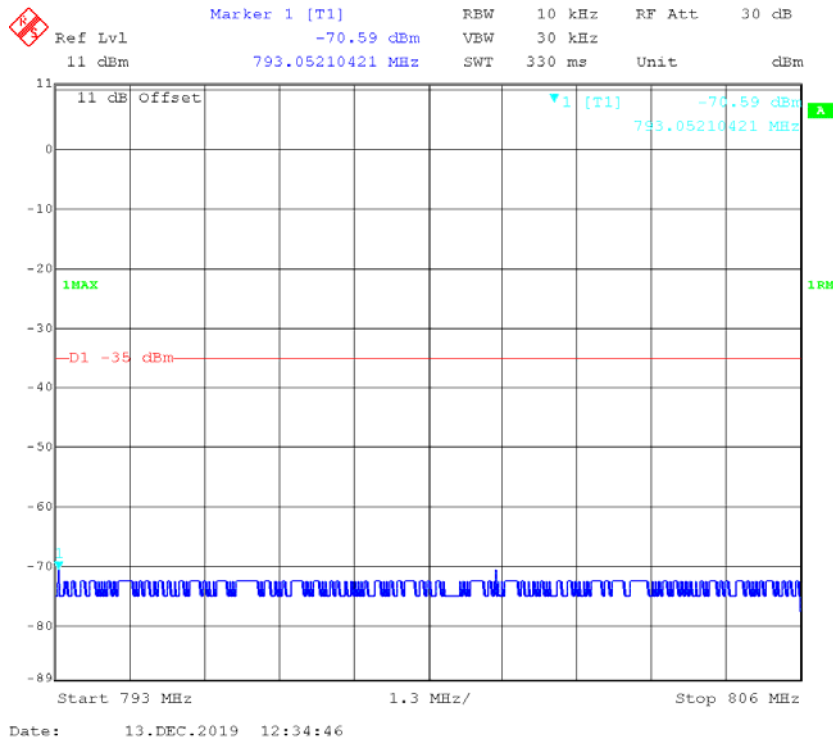
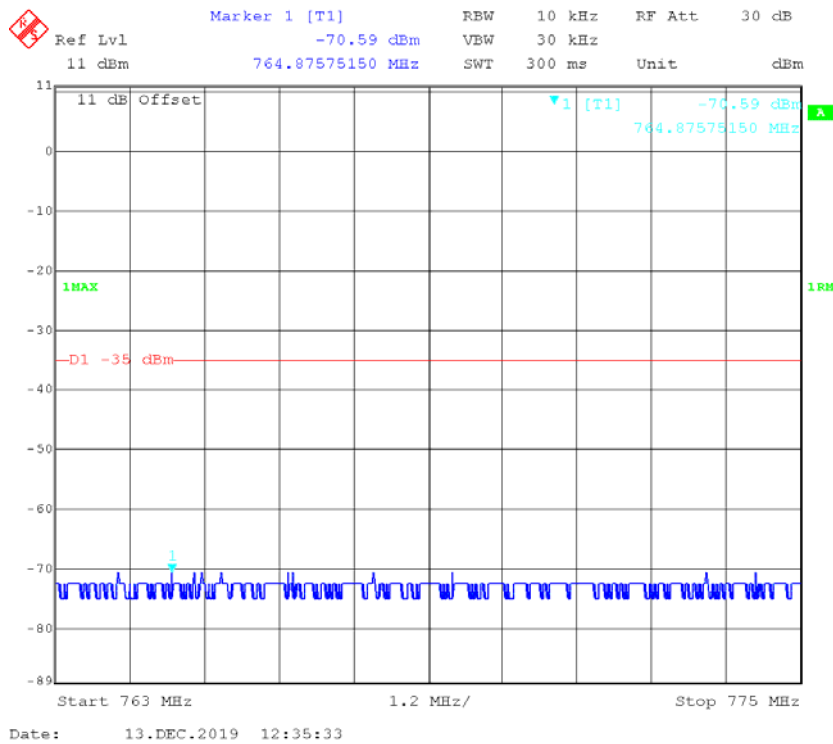

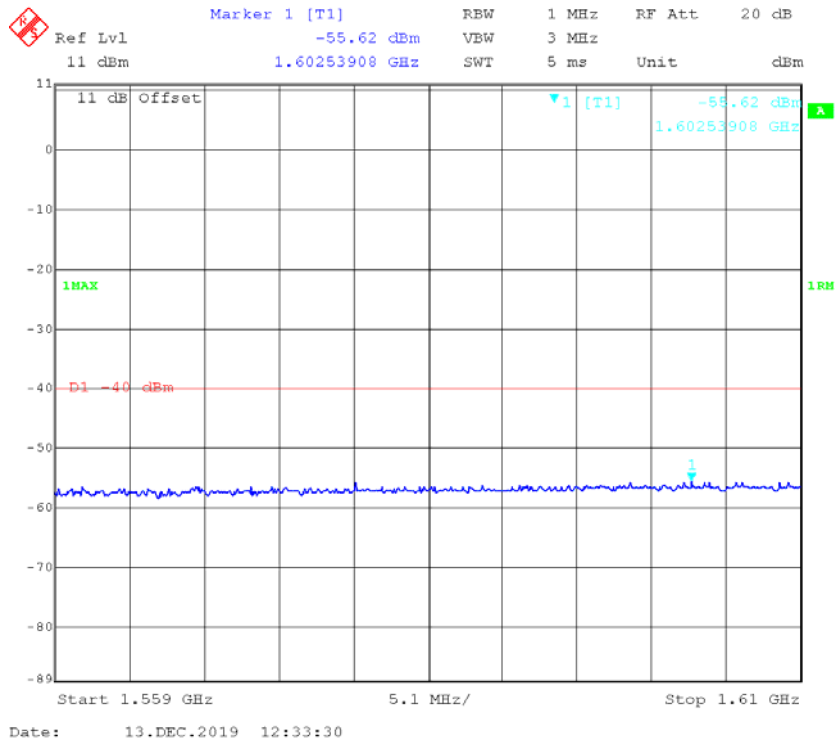

Cellular Band

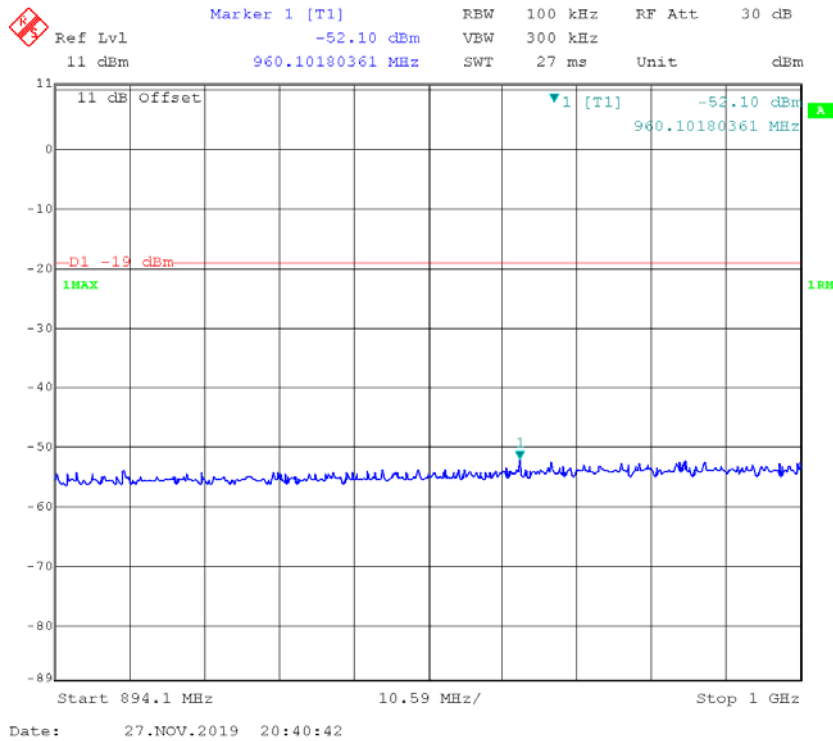
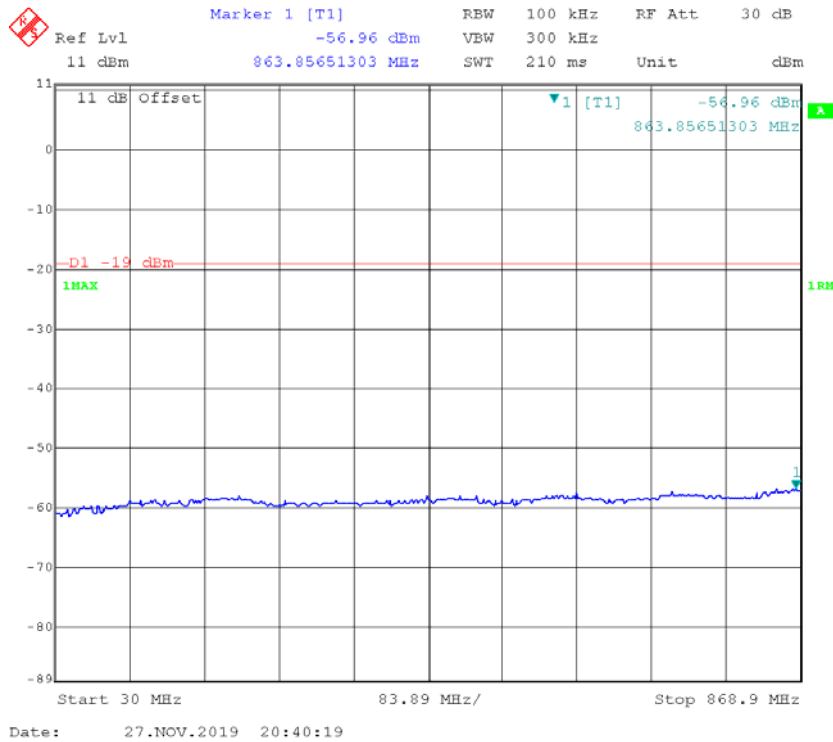

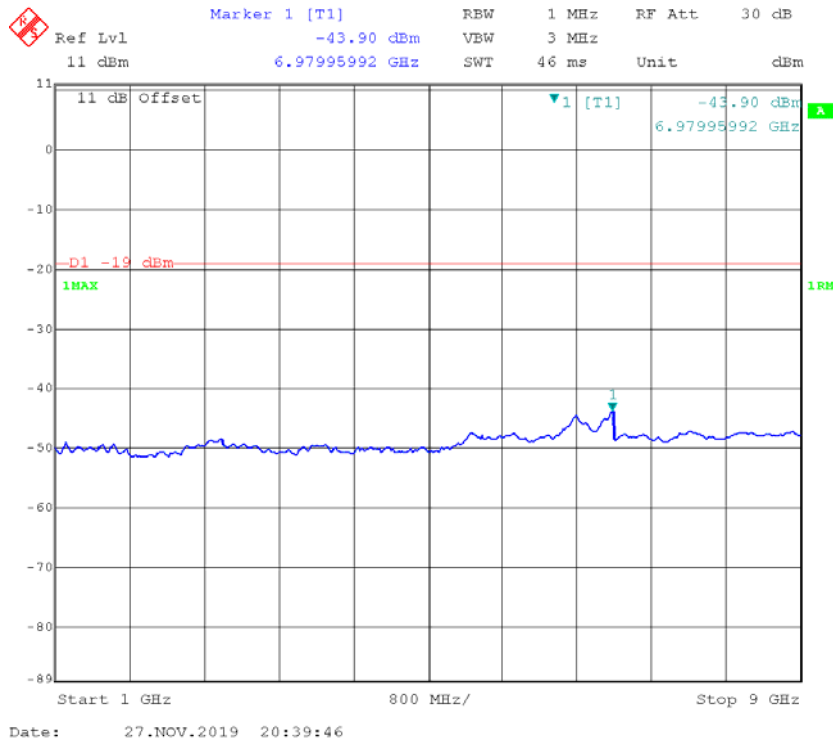

AWS Band

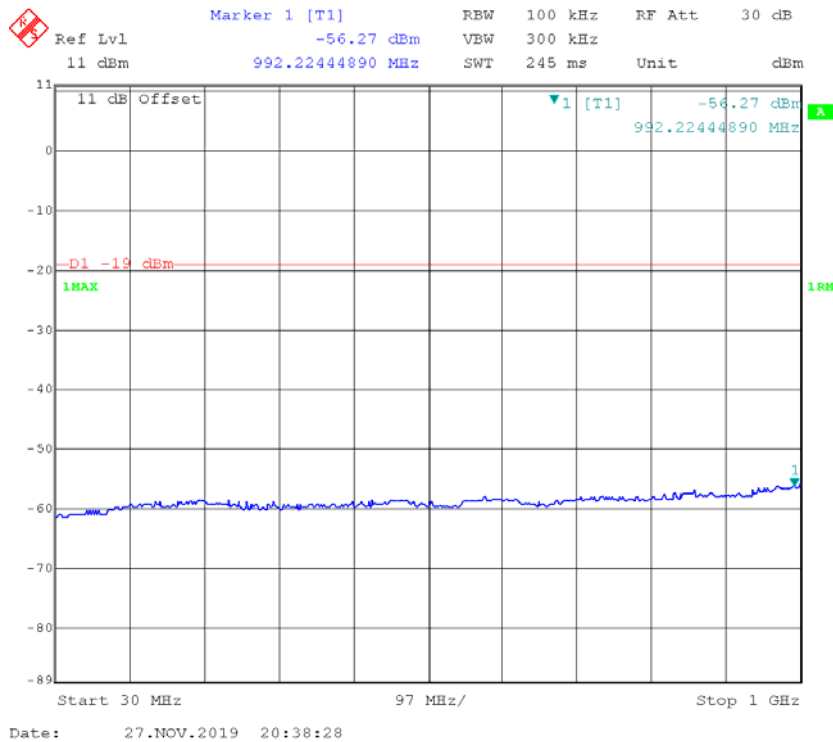

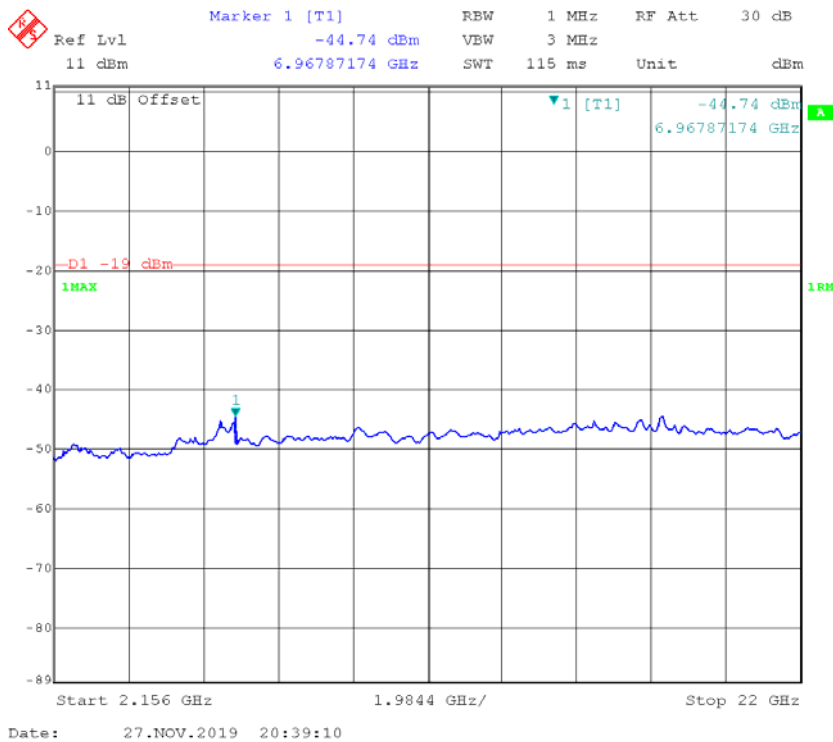
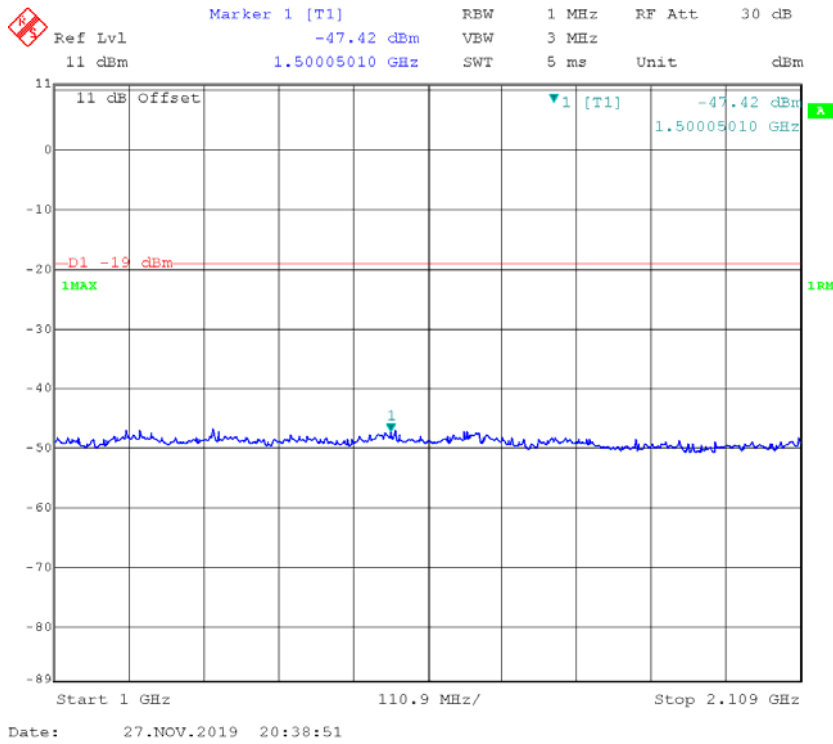

PCS Band

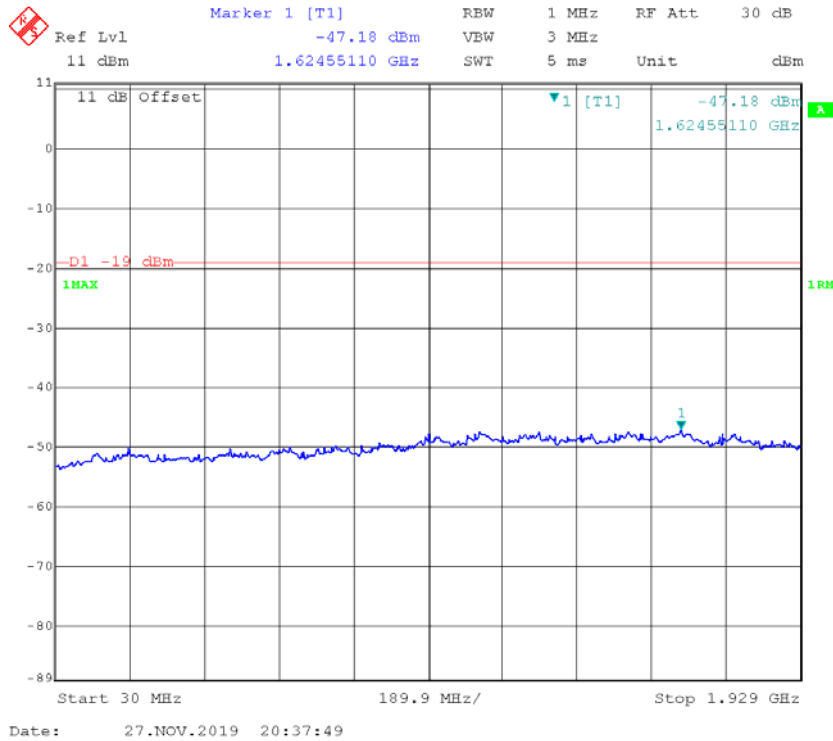
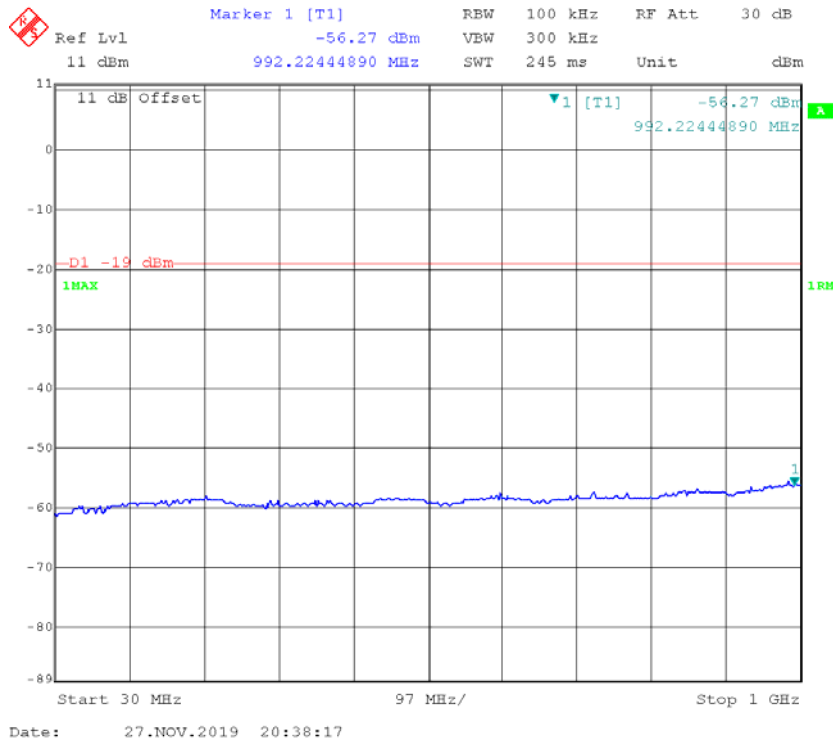

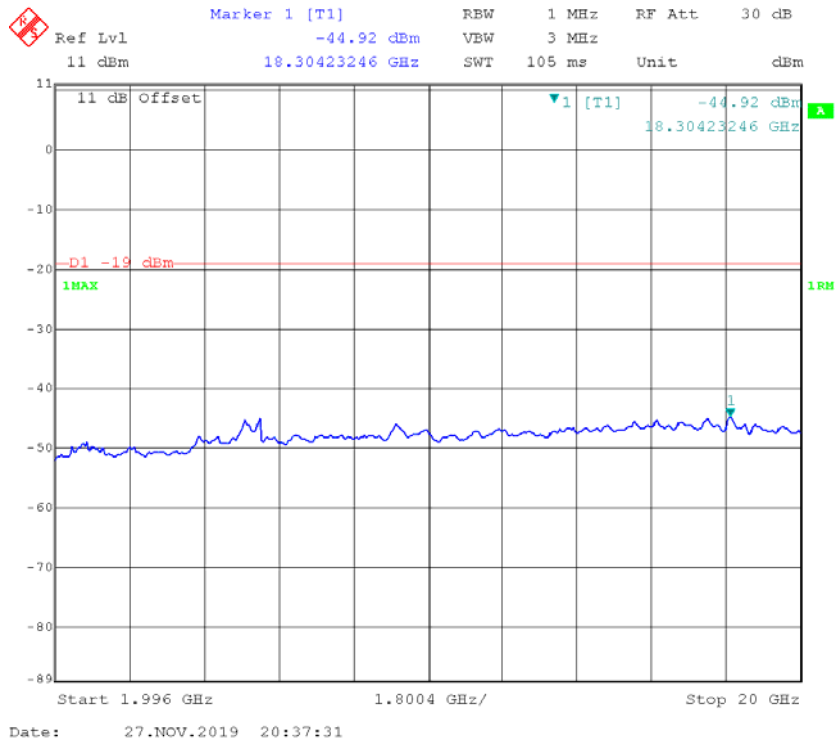

§ 2.1053 - RADIATED SPURIOUS EMISSIONS

Applicable Standards

§ 2.1053 *Measurements required: Field strength of spurious radiation.*

Test Procedure

This procedure is intended to satisfy the requirements specified in § 2.1053. The applicable limits are those specified for mobile emissions in the rule part appropriate to the band of operation (see Annex A).

- Place the EUT on an OATS or semi-anechoic chamber turntable 3 m from the receiving antenna.
- Connect the EUT to the test equipment as shown in **Figure 10** beginning with the uplink output.
- Set the signal generator to produce a CW signal with the frequency set to the center of the operational band under test and the power level set at P_{IN} as determined from 7.2.
- Measure the radiated spurious emissions from the EUT from lowest to the highest frequencies as specified in § 2.1057. Maximize the radiated emissions by utilizing the procedures described in Clause 8 of ANSI C63.4-2014.
- Capture the peak emissions plots using a peak detector with Max-Hold for inclusion in the test report. Tabular data is acceptable in lieu of spectrum analyzer plots.
- Repeat 7.12c) through 7.12e) for all operational bands.

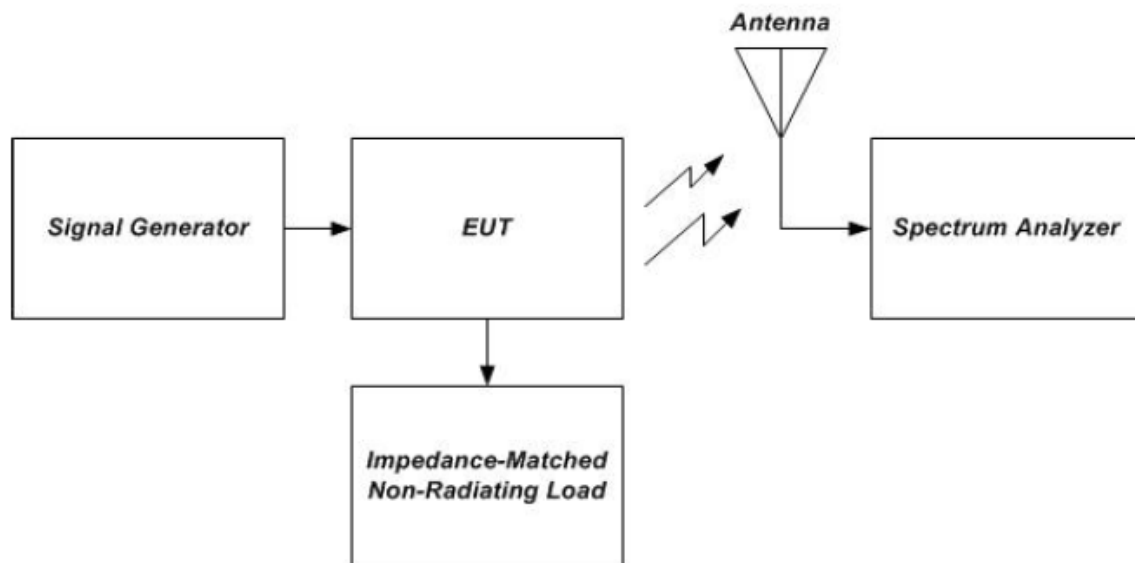

Figure 10 – Radiated spurious emissions test instrumentation setup

Test Data

Environmental Conditions

Temperature:	23.4~24.2 °C
Relative Humidity:	40~43 %
ATM Pressure:	101.1 kPa

The testing was performed by Tyler Pan and Lucy Lu on 2019-12-03.

Test Result: Compliance. Please refer to following table.

Test Mode: Transmitting

Uplink:

Frequency (MHz)	Polar (H / V)	Receiver Reading (dBµV)	Substituted Method			Absolute Level (dBm)	Limit (dBm)	Margin (dB)
			Substituted Level (dBm)	Antenna Gain (dBd/dBi)	Cable Loss(dB)			
Lower 700MHz Band, Test Frequency 707 MHz								
1200.00	H	40.02	-62.96	7.30	1.09	-56.75	-19.00	37.75
1200.00	V	40.78	-63.30	7.30	1.09	-57.09	-19.00	38.09
1599.00	H	40.44	-64.20	10.09	0.69	-54.80	-19.00	35.80
1599.00	V	42.46	-62.78	10.09	0.69	-53.38	-19.00	34.38
1414.00	H	36.45	-67.14	9.07	1.22	-59.29	-19.00	40.29
1414.00	V	36.15	-67.97	9.07	1.22	-60.12	-19.00	41.12
2121.00	H	36.22	-65.80	11.27	1.11	-55.64	-19.00	36.64
2121.00	V	36.78	-65.21	11.27	1.11	-55.05	-19.00	36.05
433.60	H	42.26	-62.36	0.00	0.64	-63.00	-19.00	44.00
541.70	V	42.78	-63.70	0.00	0.73	-64.43	-19.00	45.43
Upper 700MHz Band, Test Frequency 781.5 MHz								
1914.00	H	39.56	-63.26	11.83	1.04	-52.47	-19.00	33.47
1914.00	V	38.77	-64.37	11.83	1.04	-53.58	-19.00	34.58
1563.00	H	36.45	-68.27	9.88	0.93	-59.32	-46.00	13.32
1563.00	V	35.87	-69.26	9.88	0.93	-60.31	-46.00	14.31
2344.50	H	36.28	-66.01	11.69	1.26	-55.58	-19.00	36.58
2344.50	V	37.52	-64.80	11.69	1.26	-54.37	-19.00	35.37
371.80	H	47.07	-58.82	0.00	0.58	-59.40	-19.00	40.40
540.30	V	39.99	-66.52	0.00	0.73	-67.25	-19.00	48.25
Cellular Band, Test Frequency 836.5 MHz								
1673.00	H	37.12	-66.82	10.61	0.73	-56.94	-19.00	37.94
1673.00	V	36.45	-68.09	10.61	0.73	-58.21	-19.00	39.21
2509.50	H	36.88	-66.03	13.11	1.25	-54.17	-19.00	35.17
2509.50	V	36.84	-66.10	13.11	1.25	-54.24	-19.00	35.24
2498.00	H	39.54	-63.35	13.08	1.24	-51.51	-19.00	32.51
2498.00	V	40.67	-62.23	13.08	1.24	-50.39	-19.00	31.39
388.70	H	40.66	-64.58	0.00	0.60	-65.18	-19.00	46.18
559.90	V	44.44	-61.70	0.00	0.74	-62.44	-19.00	43.44
AWS Band, Test Frequency 1732.5 MHz								
3465.00	H	39.55	-59.64	13.91	1.62	-47.35	-19.00	28.35
3465.00	V	35.24	-63.98	13.91	1.62	-51.69	-19.00	32.69
5197.50	H	35.68	-59.01	14.00	1.52	-46.53	-19.00	27.53
5197.50	V	36.87	-57.89	14.00	1.52	-45.41	-19.00	26.41
435.40	H	41.89	-62.71	0.00	0.65	-63.36	-19.00	44.36
430.80	V	40.93	-66.96	0.00	0.64	-67.60	-19.00	48.60

Frequency (MHz)	Polar (H / V)	Receiver Reading (dBµV)	Substituted Method			Absolute Level (dBm)	Limit (dBm)	Margin (dB)
			Substituted Level (dBm)	Antenna Gain (dBd/dBi)	Cable Loss(dB)			
PCS Band, Test Frequency 1882.5MHz								
1220.00	H	46.36	-56.78	7.50	1.11	-50.39	-19.00	31.39
1221.00	V	45.27	-58.94	7.51	1.11	-52.54	-19.00	33.54
2279.00	H	40.62	-61.47	11.12	1.21	-51.56	-19.00	32.56
2280.00	V	40.12	-61.87	11.12	1.21	-51.96	-19.00	32.96
2490.00	H	41.55	-61.31	13.02	1.25	-49.54	-19.00	30.54
2491.00	V	41.23	-61.65	13.03	1.24	-49.86	-19.00	30.86
1440.00	H	46.27	-57.70	9.20	1.26	-49.76	-19.00	30.76
1441.00	V	45.83	-58.55	9.21	1.26	-50.60	-19.00	31.60
3765.00	H	35.84	-61.77	13.74	1.62	-49.65	-19.00	30.65
3765.00	V	36.81	-60.65	13.74	1.62	-48.53	-19.00	29.53
5647.50	H	36.48	-57.16	14.01	1.31	-44.46	-19.00	25.46
5647.50	V	35.22	-58.30	14.01	1.31	-45.60	-19.00	26.60
471.50	H	39.98	-64.42	0.00	0.68	-65.10	-19.00	46.10
544.50	V	40.87	-65.56	0.00	0.73	-66.29	-19.00	47.29

Downlink:

Frequency (MHz)	Polar (H / V)	Receiver Reading (dBµV)	Substituted Method			Absolute Level (dBm)	Limit (dBm)	Margin (dB)
			Substituted Level (dBm)	Antenna Gain (dBd/dBi)	Cable Loss(dB)			
Lower 700MHz Band, Test Frequency 737MHz								
1200.00	H	40.02	-62.96	7.30	1.09	-56.75	-19.00	37.75
1200.00	V	40.78	-63.30	7.30	1.09	-57.09	-19.00	38.09
1599.00	H	40.44	-64.20	10.09	0.69	-54.80	-46.00	8.8
1599.00	V	42.46	-62.78	10.09	0.69	-53.38	-46.00	7.38
2650.00	H	41.98	-60.50	13.15	1.28	-48.63	-19.00	29.63
2650.00	V	39.45	-63.23	13.15	1.28	-51.36	-19.00	32.36
1474.00	H	36.12	-68.35	9.37	1.31	-60.29	-19.00	41.29
1474.00	V	36.58	-68.12	9.37	1.31	-60.06	-19.00	41.06
2211.00	H	35.68	-66.21	10.84	1.15	-56.52	-19.00	37.52
2211.00	V	35.94	-65.84	10.84	1.15	-56.15	-19.00	37.15
544.50	H	39.50	-63.80	0.00	0.73	-64.53	-19.00	45.53
371.80	V	45.11	-63.57	0.00	0.58	-64.15	-19.00	45.15

Frequency (MHz)	Polar (H / V)	Receiver Reading (dBµV)	Substituted Method			Absolute Level (dBm)	Limit (dBm)	Margin (dB)
			Substituted Level (dBm)	Antenna Gain (dBd/dBi)	Cable Loss (dB)			
Upper 700MHz Band, Test Frequency 751.5MHz								
2498.00	H	39.27	-63.62	13.08	1.24	-51.78	-19.00	31.78
2498.00	V	38.74	-64.16	13.08	1.24	-52.32	-19.00	32.32
1502.20	H	36.87	-67.98	9.51	1.34	-59.81	-19.00	39.81
1502.20	V	37.45	-67.51	9.51	1.34	-59.34	-19.00	39.34
2253.30	H	35.87	-66.14	11.01	1.19	-56.32	-19.00	36.32
2253.30	V	35.61	-66.30	11.01	1.19	-56.48	-19.00	36.48
371.80	H	43.46	-62.43	0.00	0.58	-63.01	-19.00	43.01
310.10	V	42.09	-67.71	0.00	0.53	-68.24	-19.00	48.24
Cellular Band, Test Frequency 881.5MHz								
2498.00	H	38.55	-64.34	13.08	1.24	-52.50	-19.00	33.50
2498.00	V	38.24	-64.66	13.08	1.24	-52.82	-19.00	33.82
1763.00	H	36.45	-67.61	10.99	0.71	-57.33	-19.00	38.33
1763.00	V	36.78	-67.88	10.99	0.71	-57.60	-19.00	38.60
2644.50	H	35.87	-66.67	13.16	1.28	-54.79	-19.00	35.79
2644.50	V	36.16	-66.59	13.16	1.28	-54.71	-19.00	35.71
540.00	H	39.60	-63.79	0.00	0.73	-64.52	-19.00	45.52
433.60	V	41.70	-66.16	0.00	0.64	-66.80	-19.00	47.80
AWS Band, Test Frequency 2132.5MHz								
1199.00	H	37.88	-65.11	7.30	1.09	-58.90	-19.00	39.90
1199.00	V	37.64	-66.44	7.30	1.09	-60.23	-19.00	41.23
2490.00	H	39.09	-63.77	13.02	1.25	-52.00	-19.00	33.00
2490.00	V	38.63	-64.25	13.02	1.25	-52.48	-19.00	33.48
4265.00	H	35.78	-61.92	13.94	1.04	-49.02	-19.00	30.02
4265.00	V	36.44	-61.27	13.94	1.04	-48.37	-19.00	29.37
314.30	H	43.68	-64.41	0.00	0.53	-64.94	-19.00	45.94
443.40	V	41.57	-66.21	0.00	0.65	-66.86	-19.00	47.86
PCS Band, Test Frequency 1962.5MHz								
2490.00	H	39.56	-63.30	13.02	1.25	-51.53	-19.00	32.53
2490.00	V	39.13	-63.75	13.02	1.25	-51.98	-19.00	32.98
3925.00	H	35.78	-61.07	13.55	1.50	-49.02	-19.00	30.02
3925.00	V	36.45	-60.36	13.55	1.50	-48.31	-19.00	29.31
5887.50	H	37.12	-55.23	14.01	1.75	-42.97	-19.00	23.97
5887.50	V	36.22	-56.20	14.01	1.75	-43.94	-19.00	24.94
336.70	H	39.57	-67.66	0.00	0.55	-68.21	-19.00	49.21
444.80	V	41.84	-65.92	0.00	0.65	-66.57	-19.00	47.57

Note:

- 1) Absolute Level = Substituted Level - Cable loss + Antenna Gain
- 2) Margin = Limit- Absolute Level
- 3) The unit of antenna gain is dBd for frequency below 1GHz and is dBi for frequency above 1GHz.

******* END OF REPORT *******