



313 West 12800 South, Suite 311
Draper, UT 84020
(801) 260-4040

Test Report

Certification

FCC ID	2AJAC-TSSA1200
Equipment Under Test	TS-SA1-200
Test Report Serial No	V070357_02
Date of Test	October 5, 2023
Report Issue Date	October 5, 2023

Test Specifications:	Applicant:
FCC Part 15, Subpart E FCC KDB 905462 D02 UNII DFS Compliance Procedures New Rules v02 FCC KDB 905462 D03 UNII Clients Without Radar Detection New Rules v01r02	Snap One LLC 1800 Continental Blvd., Suite 200-300 Charlotte NC 28273 U.S.A.



Certification of Engineering Report

This report has been prepared by VPI Laboratories, Inc. to document compliance of the device described below with the requirements of Federal Communications Commission (FCC) Part 15, Subpart E. This report may be reproduced in full. Partial reproduction of this report may only be made with the written consent of the laboratory. The results in this report apply only to the sample tested.

Applicant	Snap One LLC
Manufacturer	Snap One LLC
Brand Name	Snap One
Model Number	TS-SA1-200
FCC ID	2AJAC-TSSA1200

On this 5th day of October 2023, I, individually and for VPI Laboratories, Inc., certify that the statements made in this engineering report are true, complete, and correct to the best of my knowledge, and are made in good faith.

Although NVLAP has accredited the VPI Laboratories, Inc. EMC testing facilities, this report must not be used to claim product certification, approval, or endorsement by NVLAP, NIST, or any agency of the federal government.

VPI Laboratories, Inc.



Tested by: Benjamin N. Antczak



Reviewed by: Jason Stewart

Revision History		
Revision	Description	Date
01	Original Report Release	October 5, 2023
02	Removing Photographs from Report	December 29, 2023

Table of Contents

1	Client Information.....	5
1.1	Applicant.....	5
1.2	Manufacturer.....	5
2	Equipment Under Test (EUT).....	6
2.1	Identification of EUT.....	6
2.2	Description of EUT.....	6
2.3	EUT and Support Equipment.....	6
2.4	Interface Ports on EUT.....	7
2.5	Modification Incorporated/Special Accessories on EUT.....	7
2.6	Deviation from Test Standard.....	7
2.7	Scope of This Report.....	7
2.8	Test Specification.....	8
2.9	Methods & Procedures.....	8
2.10	Test Procedure.....	9
3	Operation of EUT During Testing.....	10
3.1	Operating Environment.....	10
3.2	Operating Modes.....	10
3.3	EUT Exercise Software.....	10
4	Summary of Test Results.....	11
4.1	FCC Part 15, Subpart E.....	11
4.2	Result.....	11
5	Measurements, Examinations and Derived Results.....	12
5.1	General Comments.....	12
6	Test Procedures and Test Equipment.....	16
6.1	Direct Connection at the Antenna Port Test.....	16
6.2	Equipment Calibration.....	17
6.3	Measurement Uncertainty.....	17
7	Photographs.....	18

1 Client Information

1.1 Applicant

Company Name	Snap One LLC 1800 Continental Blvd., Suite 200-300 Charlotte NC 28273 U.S.A.
Contact Name	Roger Midgley
Title	Sr. Regulatory Compliance Engineer

1.2 Manufacturer

Company Name	Snap One LLC 1800 Continental Blvd., Suite 200-300 Charlotte NC 28273 U.S.A.
Contact Name	Roger Midgley
Title	Sr. Regulatory Compliance Engineer

2 Equipment Under Test (EUT)

2.1 Identification of EUT

Brand Name	Snap One
Model Number	TS-SA1-200
Serial Number	ST232200250316F230
Dimensions (cm)	22 x 22 x 7

2.2 Description of EUT

The TS-SA1-200 uses the 2.4 GHz ISM band and the 5 GHz UNII bands.

2.2.1 Modes of Operation

EUT is able to operate within the UNII-2 bands (5.25 – 5.35 GHz and 5.47 – 5.725 GHz) as a Client device only. Client devices are not able to directly communicate with each other (mesh) with or without association with a “Master” AP device.

2.2.2 DFS Capabilities

EUT utilizes DFS but cannot operate in a master operational mode. As a Client only device, compliance requirements for channel move time and non-occupancy is applicable.

2.3 EUT and Support Equipment

The EUT and support equipment used during the test are listed below.

Brand Name Model Number Serial Number	Description	Name of Interface Ports / Interface Cables
BN: Snap One MN: TS-SA1-200 (Note 1) SN: ST232200250316F230 MAC: 000FFF0C41BB	Streaming Amplifier with Wireless Capabilities	Antenna Port to Test System See Section 2.4
BN: Panasonic MN: CF-31 SN: 3DTYB38805	“Control Subnet” Laptop PC	LAN / Ethernet Cat 5e
BN: Lenovo MN: T460s SN: PC-0C3DZW	“Wireless Subnet” Laptop PC	LAN / Ethernet Cat 5e to “Wireless Subnet” Router
BN: Linksys MN: EA8300 SN: 21P10M25A07785	DFS Capable AP FCC ID: Q87-EA8300 (“Wireless Subnet” Router)	Antenna Port Connection to Test System LAN / Ethernet Cat 5e to “Wireless Subnet” PC

Brand Name Model Number Serial Number	Description	Name of Interface Ports / Interface Cables
BN: Netgear MN: R7000 SN: 44214877A4B41	Ethernet Subnet for EUT and Control Laptop ("Control Subnet" Router)	Network / Ethernet Cat 5e to "Control Subnet" PC Network/ Ethernet Cat5e to EUT

Notes: (1) EUT

(2) Interface port connected to EUT (See Section 2.4)

The support equipment listed above was not modified in order to achieve compliance with this standard.

2.4 Interface Ports on EUT

Name of Ports	No. of Ports Fitted to EUT	Cable Description/Length
Network	1	Ethernet Cat 5e to "Control Subnet" Router / 1m

2.5 Modification Incorporated/Special Accessories on EUT

There were no modifications or special accessories required to comply with the specification.

2.6 Deviation from Test Standard

There were no deviations from the test specification.

2.7 Scope of This Report

This report covers the circuitry of the devices subject to DFS requirements of FCC Part 15, Subpart E. with operation in the 5250 MHz to 5725 MHz frequency band. Circuitry for UNII bands were found to be compliant in VPI Laboratories, Inc. reports V070354, V070355, and V070356.

VPI The circuitry of the device is additionally subject to, and found to be compliant with, FCC Part 15 Subparts C. Compliance with Subpart C is covered in VPI Laboratories, Inc. report V070353.

3 Test Specification, Methods and Procedures

3.1 Test Specification

Title	KDB 789033 Guidelines for Compliance Testing of Unlicensed National Information Infrastructure (U-NII) Devices Part 15, Subpart E KDB 905462 D02 UNII DFS Compliance Procedures New Rules v02
Purpose of Test	The tests were performed to demonstrate initial compliance

3.2 Methods & Procedures

3.2.1.1 Radar Detection Function of Dynamic Frequency Selection

UNII devices that operate with any part of their 26 dB emission bandwidth in the UNII-2 bands must employ a DFS radar detection mechanism to avoid co-channel operation with radar systems. Upon detection of radar signals, the channel must be flagged as containing a radar system and must not be utilized for at least 30 minutes (“Non-occupancy Period”).

The DFS detection threshold is -64 dBm for devices with a maximum e.i.r.p. between 200 mW and 1 W. Devices for which e.i.r.p. is less than 200 mW and for which maximum power spectral density is less than 10 dBm per 1 MHz band shall have a DFS threshold of -62 dBm.

Radar signals must be detected at 100 percent of the device’s emission bandwidth. DFS detection threshold is the received power averaged over 1µs and referenced to a 0 dBi antenna.

Some standards such as IEEE 801.11.ax allow wideband transmissions that are “notched” or “punctured” upon radar detection (e.g., 160 MHz wideband transmissions wherein a 20 MHz portion of the bandwidth is not utilized). For such transmission schemes, the remaining emissions of the notched signal shall not bleed into the notch (i.e., 26 dB or 99% bandwidth is outside the notch). Channel closing and moving times must be met when notches are utilized.

3.2.2 Operational Modes and DFS Requirements

UNII devices can operate as a Master device or a Client device. The classification of the UNII device determines which DFS requirements are applicable. All Master devices must have radar detection capabilities, while Client devices are classified as either Client With Radar Detection or Client Without Radar Detection.

All DFS devices, Master or Client, must fulfil the Channel Move Time requirement, forcing all transmissions to cease operating on a channel within 10 seconds of detecting a radar signal. Transmissions may continue with normal traffic for a maximum of 200 ms after the detection of radar, but only control and management signals may exist after 200 ms to assist in the vacating of the occupied channel. Control and management signals are not allowed after 10 seconds.

Only DFS devices operating as a master device must fulfil the Channel Availability Check time requirement. Master devices must check if there are radar signals already operating on a channel before initiating transmission (or changing channels). If no radar signals are detected above the DFS detection threshold within 60 seconds, the channel may be utilized. Initial channel selection may be either randomly selected or manually selected.

Devices classified as Client With Radar Detection is not responsible for Channel Availability Check times, but must observe the Non-Occupancy Period, the DFS Detection Threshold, and the UNII Detection Bandwidth requirements prior to the use of a DFS channel. During normal operations, Clients With Radar Detection shall comply with the same requirements as Master Devices. Clients Without Radar Detection are only responsible for Channel Closing Transmission Time and Channel Move Time requirements.

3.3 Test Procedure

VPI Laboratories, Inc. is accredited by National Voluntary Laboratory Accreditation Program (NVLAP); NVLAP Lab Code: 100272-0, which is effective until September 30, 2024. VPI Laboratories, Inc. carries FCC Accreditation Designation Number US5263. VPI Laboratories main office is located at 313 W 12800 S, Suite 311, Draper, UT 84020. The testing was performed according to the procedures in ANSI C63.10-2013, KDB 789033, KDB 905462, and 47 CFR Part 15.

4 Operation of EUT During Testing

4.1 Operating Environment

Power Supply	3.3 VDC from host device
--------------	--------------------------

4.2 Operating Modes

EUT and Master Device were set to operate in N-mode on UNII2 Channel 100 (5500 MHz). EUT is a Client Without Radar Detection and only capable of operation at 20 MHz bandwidth. Direct connect test setup described in Section 7.2 of KDB 905462 D02 for Client with Injection at Master was utilized:

7.2.2 Setup for Client with injection at the Master

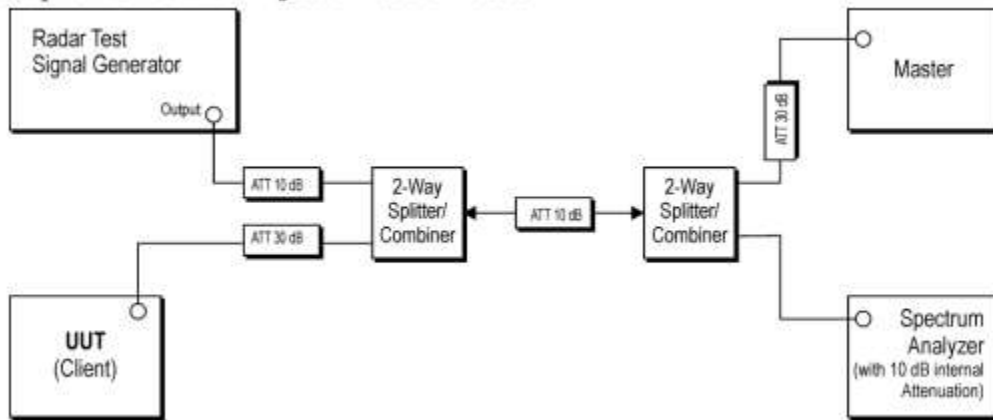

Figure 1: Test Setup for Radar Injection at the Master Device (KDB 905462 D02 v02, p.16)

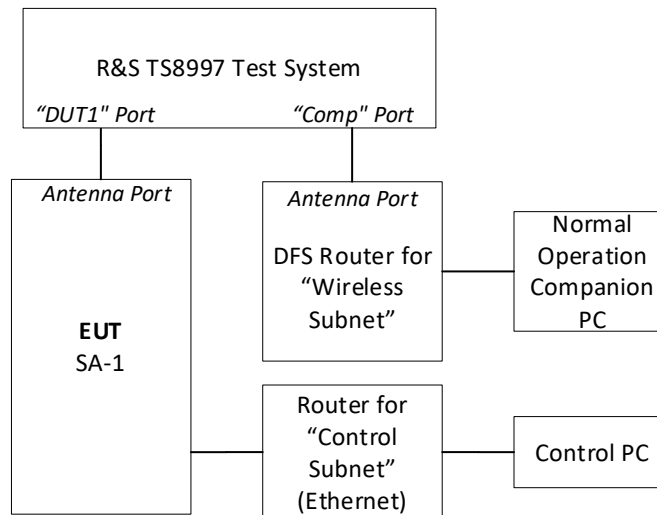

Figure 2: EUT and DFS Router Configuration

4.3 EUT Exercise Software

Control4 firmware was used to exercise and control the transmitter for testing.

5 Summary of Test Results

5.1 FCC Part 15, Subpart E

5.1.1 UNII-2 Transmit Power Control and Dynamic Frequency Selection Tests

Section	Environmental Phenomena	Result
15.407(h)(1)	Transmit Power Control	Note 1
15.407(h)(2)	DFS Radar Detection Threshold	Note 2
15.407(h)(2)(ii)	DFS Channel Availability Check Time	Note 2
15.407(h)(2)(iii)	DFS Channel Closing Transmission Time	Complied
15.407(h)(2)(iii)	DFS Channel Move Time	Complied
15.407(h)(2)(iv)	DFS Non-Occupancy Period	Complied

Note 1: EUT transmission levels do not require TPC in the evaluated configuration.

Note 2: EUT is a Client Without Radar Detection and this requirement is not applicable.

5.2 Result

In the configuration tested, the EUT complied with the requirements of the specification.

6 Measurements, Examinations and Derived Results

6.1 General Comments

This section contains the test results only. Details of the test methods used and a list of the test equipment used during the measurements can be found in Section 7 of this report.

6.1.1 §15.407(h)(1) TPC

Based upon the conducted output power measurements, EUT does not require a transmit power control mechanism to operate in the UNII-2 band in the configuration tested.

Result

In the configurations tested the EUT complied with the requirements of the specification.

6.1.2 §15.407(h)(2) DFS

DFS was tested in N-Mode, transmitting on channel 100 (5500 MHz). EUT is a Client Without Radar Detection and operates only with a Bandwidth of 20 MHz. EUT was tested with a Linksys EA8300 Router (FCC ID: Q87-EA8300) as the Master Device. EUT successfully responded to Master Device's CSA and changed channels to 104 (5520 MHz).

6.1.3 Radar Detection

EUT does not operate as a Master device in the UNII-2 Band and cannot detect radar in the configurations tested.

Result

In the configurations tested the EUT complied with the requirements of the specification.

6.1.4 Master Device Channel Availability Check Time

EUT does not operate as a master device in the UNII-2 Band and cannot detect radar in the configurations tested.

Result

In the configurations tested the EUT complied with the requirements of the specification.

6.1.5 Channel Closing Transmission Time and Channel Move Time

EUT was set for continuous UDP traffic via iperf. Upon receiving a clear channel command from a Master device, EUT cleared transmissions within 10 seconds. No transmission by the EUT was detected on 5500 MHz after the Move Time.

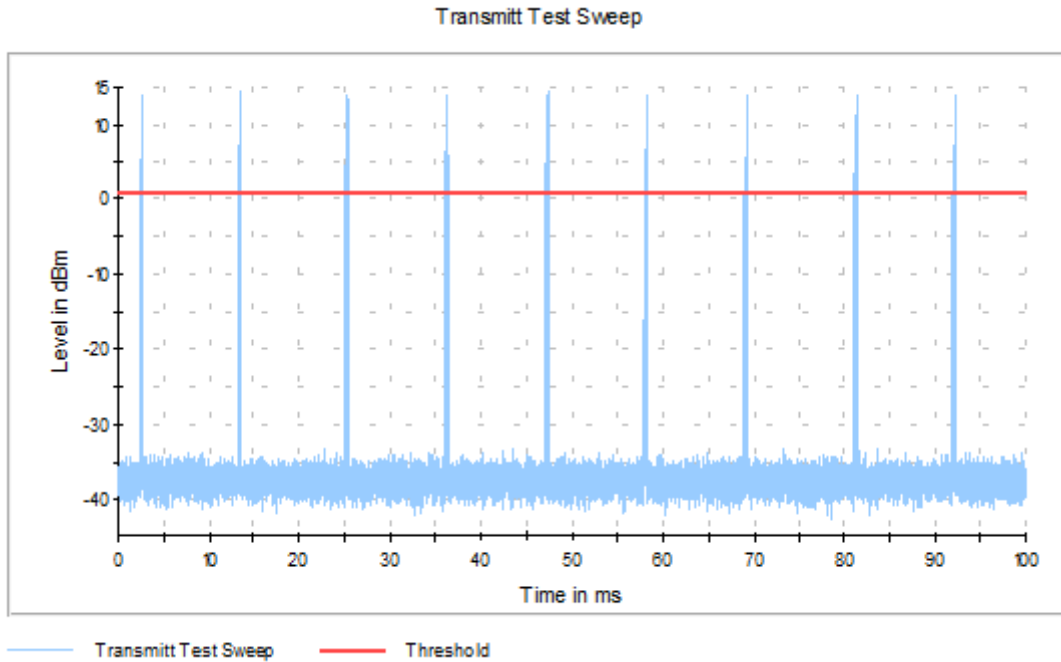

Graph 1: Normal Operation Before Radar Ping on Channel 100

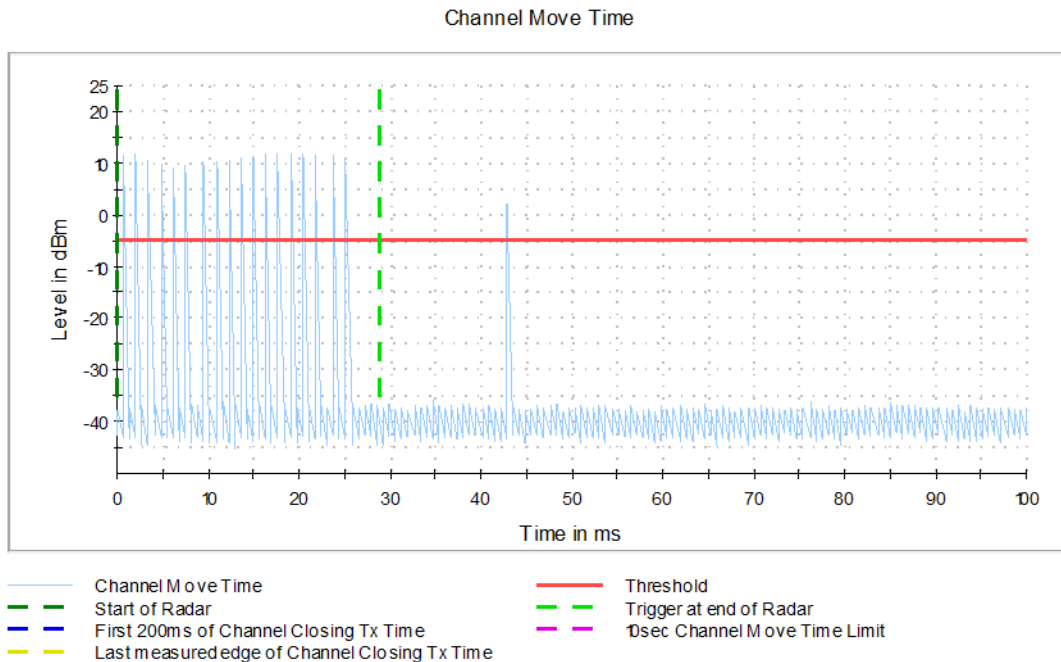

Graph 2: EUT Channel 100 Channel Close Time and Channel Move Time

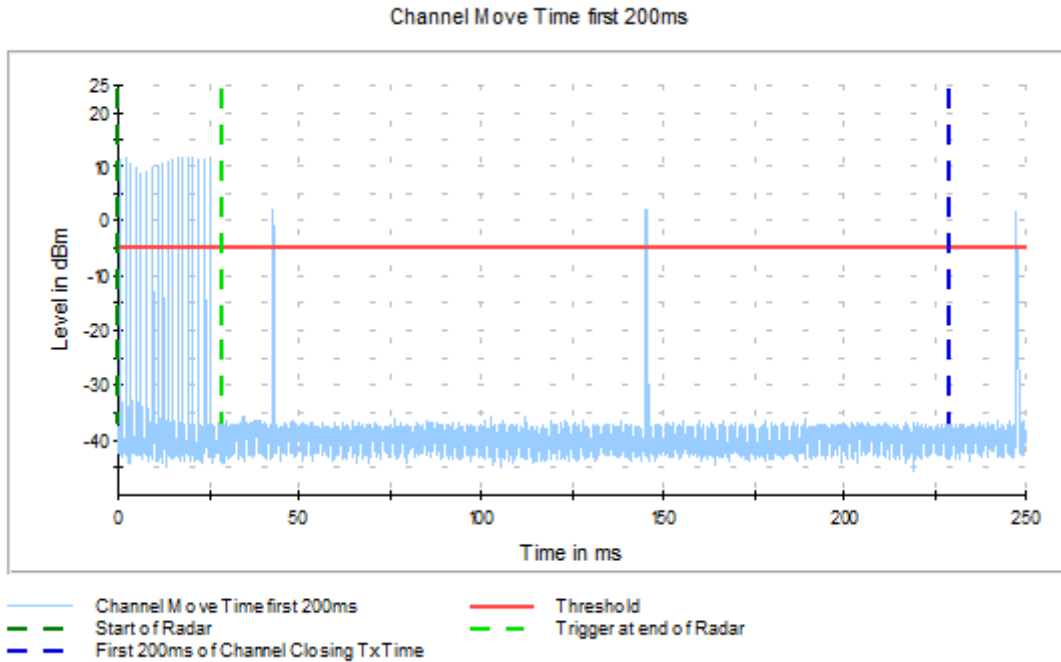

Graph 3: EUT Channel 56 First 200 ms (Channel Closing Tx Time)

6.1.6 Channel Non-Occupancy Period

Upon receiving Clear Channel command, EUT only transmitted on Channel 104 for 30 minutes.

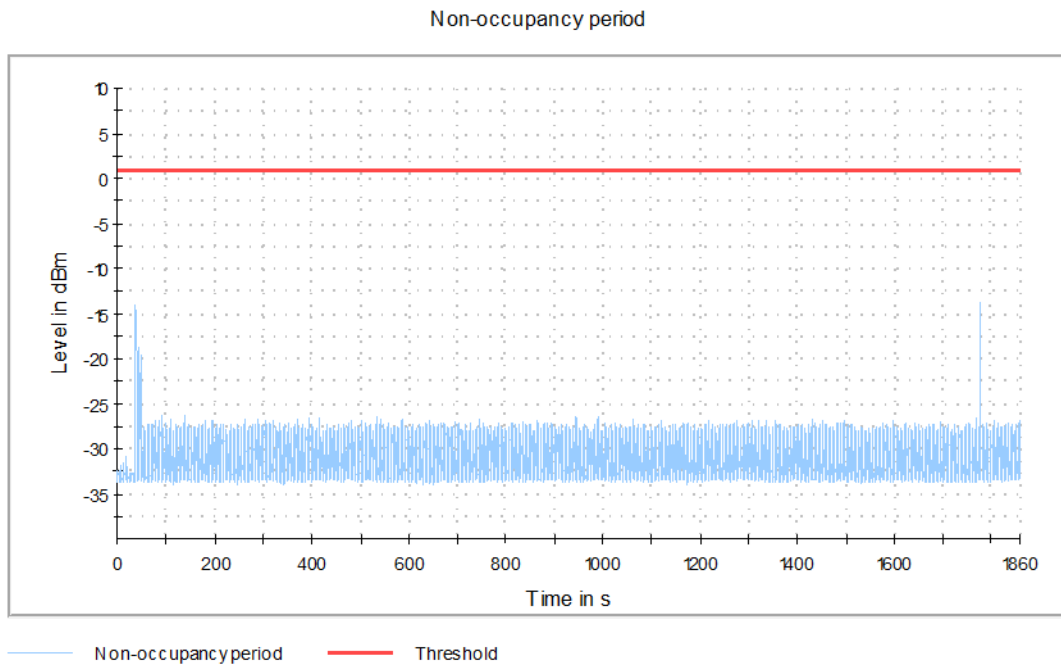

Graph 4: EUT Channel 56 Non-Occupancy Period of 30 minutes.

Result

In the configurations tested the EUT complied with the requirements of the specification.

7 Test Procedures and Test Equipment

7.1 Direct Connection at the Antenna Port Test

Type of Equipment	Manufacturer	Model Number	Asset Number	Date of Last Calibration	Due Date of Calibration
Spectrum Analyzer	Rohde & Schwarz	FSU40	V044352	03/08/2022	03/08/2024
Signal Generator	Rohde & Schwarz	SMB100A	V044485	04/03/2023	04/03/2024
Vector Signal Generator	Rohde & Schwarz	SMBV100A	V044217	03/08/2022	03/08/2024
40GHz Switch Extension	Rohde & Schwarz	OSP-150	V044486	09/25/2023	09/25/2025
40GHz Switch Base Unite	Rohde & Schwarz	OSP-120	V044487	03/23/2022	04/30/2024

Table 1: List of equipment used for conducted emissions testing at antenna ports.

7.1.1 Test Configuration Block Diagram

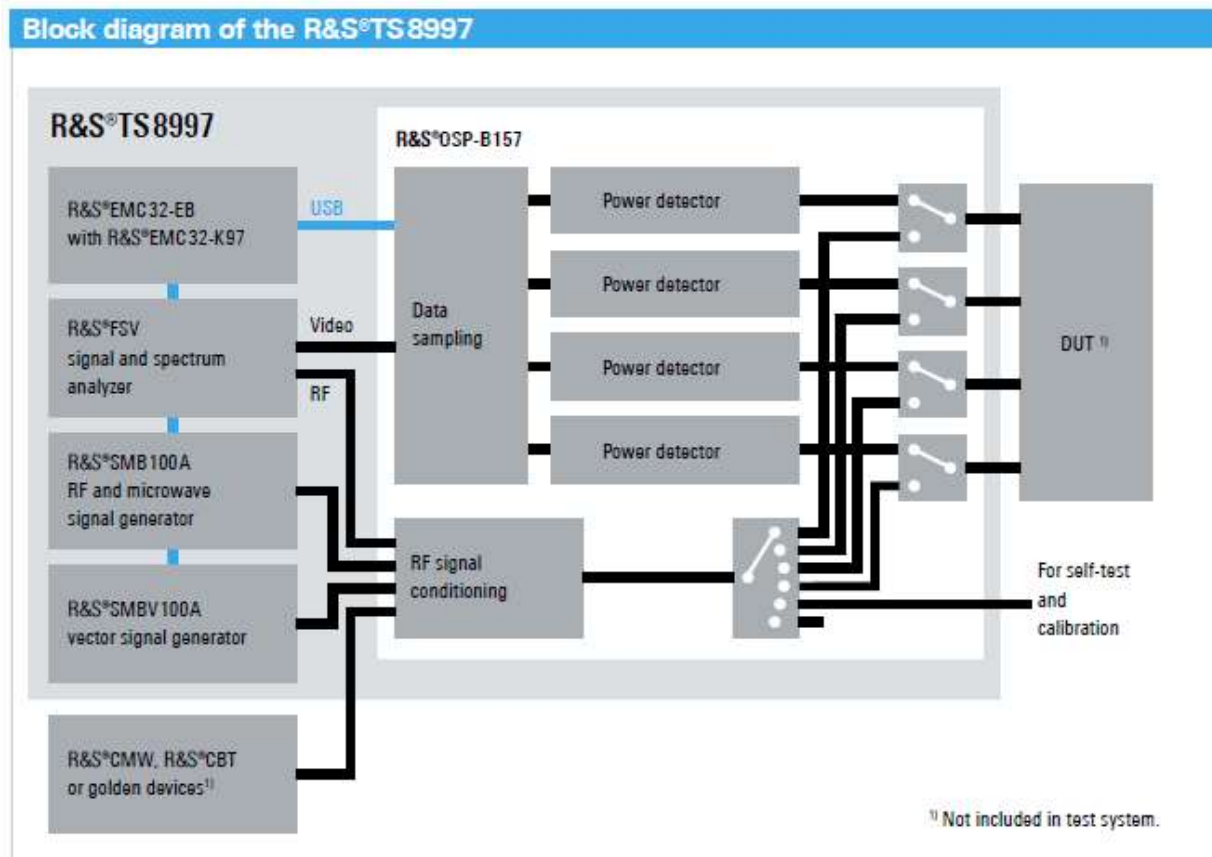

Figure 5: Direct Connection at the Antenna Port Test

7.2 Equipment Calibration

All applicable equipment is calibrated using either an independent calibration laboratory or VPI Laboratories, Inc. personnel at intervals defined in ANSI C63.4:2014 following outlined calibration procedures. All measurement instrumentation is traceable to the National Institute of Standards and Technology (NIST). Supporting documentation relative to tractability is on file and is available for examination upon request.

7.3 Measurement Uncertainty

Test	Uncertainty (\pm dB)	Confidence (%)
Conducted Emissions	2.8	95

8 Photographs

Photographs are contained in an external appendix.

--- End of Report ---