



AN-X20-AP-I

Wi-Fi 6 Wireless Access Point

Quick Start Guide



Welcome to Araknis Networks™

Thank you for choosing an Araknis™ Wi-Fi 6 Wireless Access Point (WAP). With circular housing, an easy mounting system, convenient PoE power, and the latest Wi-Fi 6 wireless technologies, these products are ideal as staples in both residential and commercial applications.

Features

- 802.11AX WiFi-6 Certified
- Sleek circular design
- 1 x 2.5 Gigabit LAN port w/PoE-IN
- 1 x Gigabit LAN port (data only)
- AN-520-AP-I/AN-520-AP-I-1: 2x2 dual-band 802.11AX 3000Mbps
- OvrC enabled

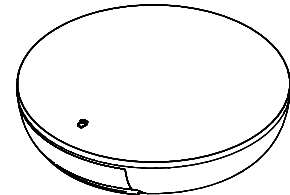

AN-520-AP-I
AN-520-AP-I-1

Step 1: Unbox

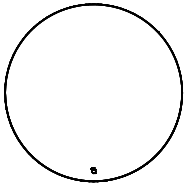

Wireless Access Point
(WAP)

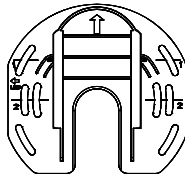

Mounting Bracket

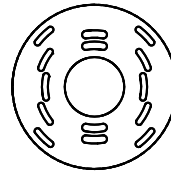

Tile Ceiling Backing Plate

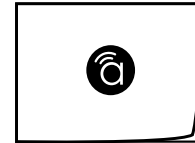

Quick Start Guide

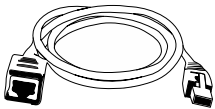

Male-to-Female
Category Jumper Cable



Tile Ceiling
Mounting Hardware

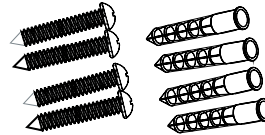

Drywall
Mounting Hardware

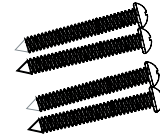

Wood Surface
Mounting Hardware

Note: This manual uses the 820 WAP for illustrative purposes throughout.

Step 2: Install

How to Remove the Cable Bay Cover

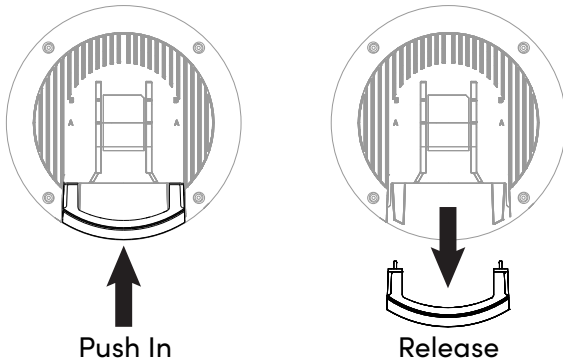

Ceiling Mount

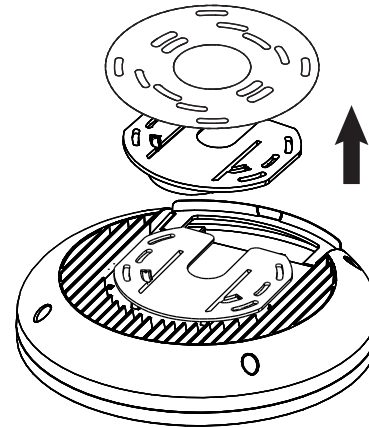

Note: Use the ceiling back plate on top of acoustic ceiling tiles to prevent the mounting nuts from pulling through.

Position the Ceiling Mount

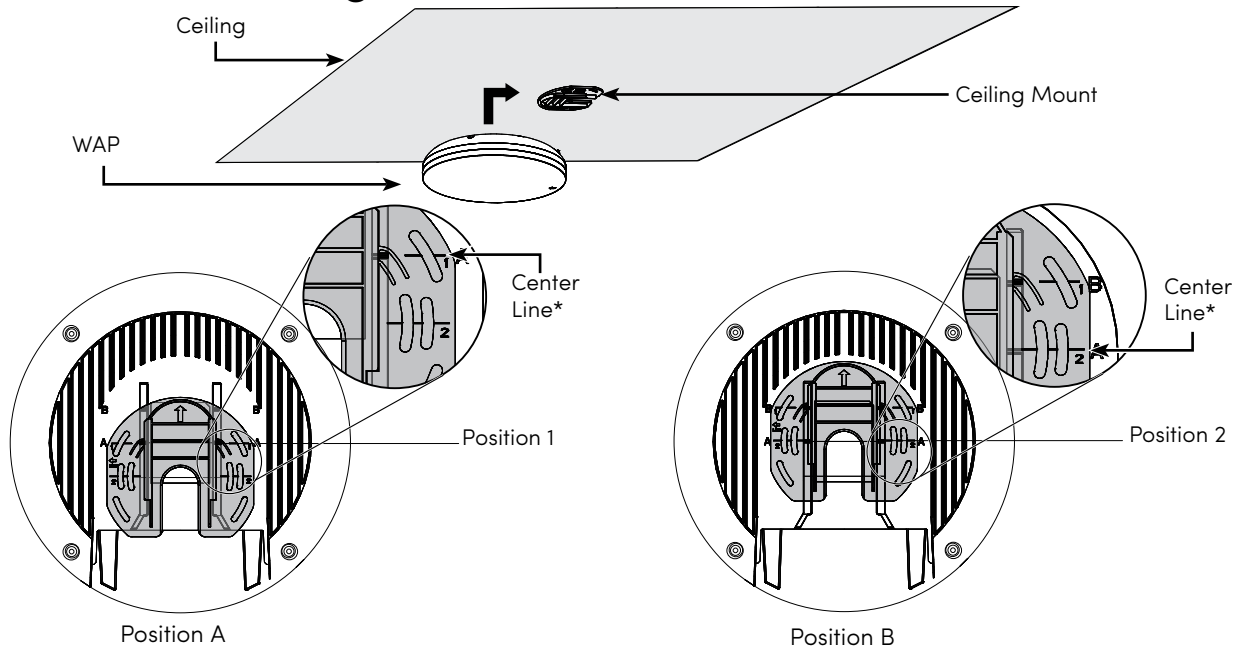

* Center line of the bracket is not necessarily the center line of the WAP when installed. Use the above guide to understand the center line of the WAP when installing the bracket.

Recommended use of the Jumper Cable

You can mount your access point to the electrical box in one of two positions, shown below. These options are provided to provide cable bend relief for cables of different lengths and thicknesses. **Illustrations do not reflect pre-install steps. Run the wire or jumper prior to connecting the access point.**

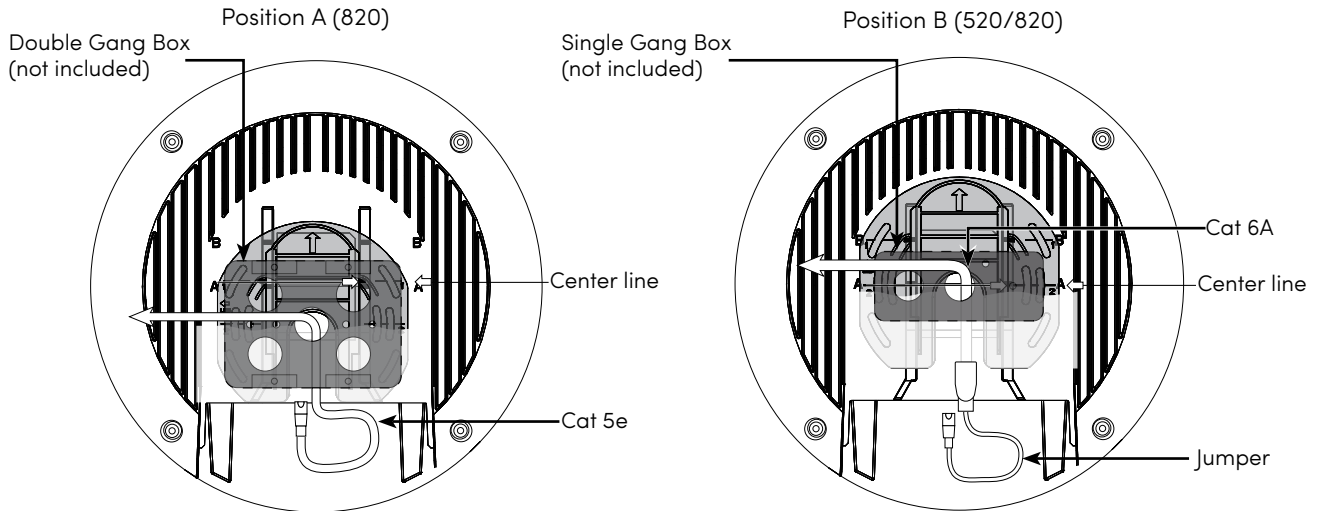

Note: Jumper is needed when using Cat 6A in Position B.

Step 3: Connect

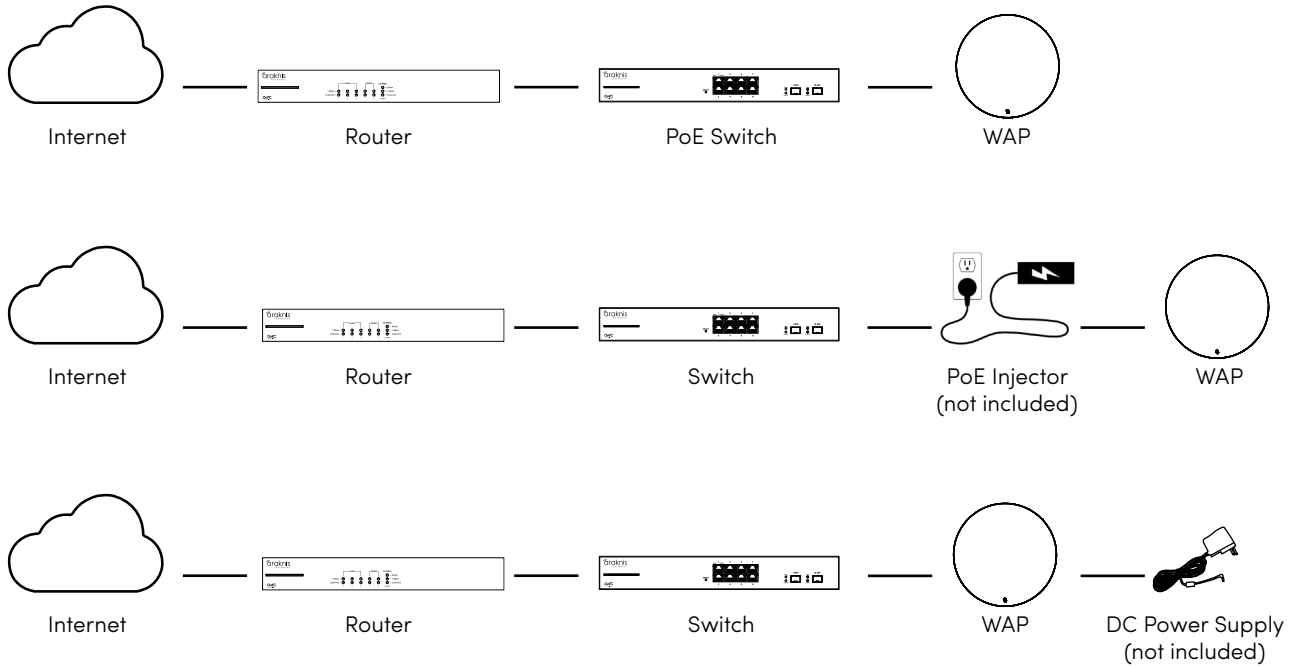

Step 4: Operation

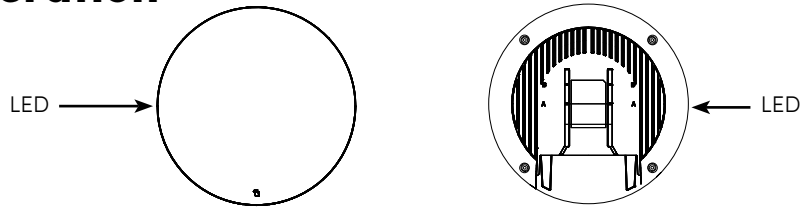

LED States

AP State	LED State	Description
Operational States	No LED	The AP is not powered on
	Solid White	The AP is in a startup process at the uboot stage
	Blinking White	The AP is in a startup process at the kernel stage
	Solid Blue	The AP started correctly and is running in an operational state
	Blinking Blue	The AP is operating but is underpowered
	Solid Red	The AP is non-functional
Error States	Blinking Orange	The AP is not connected to the internet
	Blinking Green	The AP is performing a firmware update
	Solid Orange	The AP failed a firmware update and needs to be recovered

Reset Procedures

The reset button can be found in the WAP's cable bay.

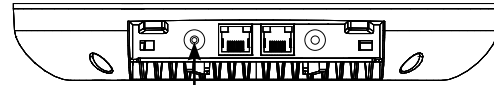

Reset Button

Reset Password UI Toggle	Reset Button Action	LED State	Description
Reset Password UI Toggle Enabled	Reset button held for 1-9 seconds	Blinking Green	The AP restarts
	Reset button held for 10-19 seconds	Blinking Orange	Only the username and password are reset
	Reset button held for more than 20 seconds	Blinking Red	The AP is set to factory defaults
Reset Password UI Toggle Disabled	Reset button held for 1-19 seconds	Blinking Green	The AP restarts
	Reset button held for more than 20 seconds	Blinking Red	The AP is set to factory defaults

Step 5: Configuration

Araknis WAPs can be configured through OvrC or the local interface. The local interface is accessible using OvrC's webconnect feature, typing the WAP's DHCP address into your browser's address bar, or using the WAP's default IP address.

Configuration Through OvrC

OvrC gives you Wi-Fi management, remote device management, real-time notifications, and intuitive customer management, right from your computer or mobile device. Setup is plug-and-play, with no port forwarding or DDNS address required. **To add this device to your OvrC account:**

1. Connect the WAP to the Internet
2. Log Into OvrC (www.ovrc.com)
3. Add the Device (MAC address and Service Tag numbers needed for authentication)

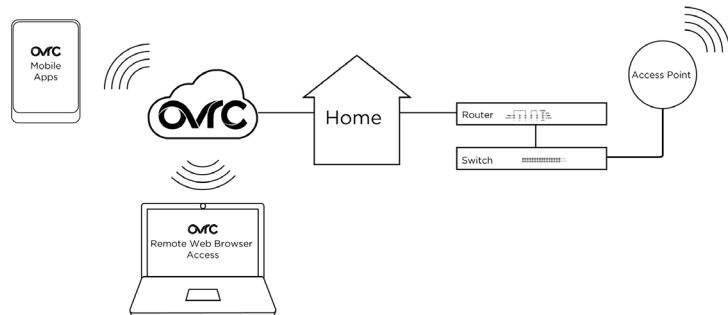

Logging in to the Local Interface

1. Log into the WAP using the default credentials:

Username	araknis
Password	araknis

2. You must update the password after initial login.



The screenshot shows the login page for Araknis Networks. On the left is a dark blue vertical bar with the white logo 'araknis NETWORKS'. To the right, there is a white login form with two text input fields labeled 'Username' and 'Password'. Below these fields is a green rectangular button with the text 'Log In' in white.

Pro Tip: Strong passwords are long and unrelated to the client's public details. For example, *thepeppero-nipizzas* is stronger and easier to remember than *P@ssword* or *thesmiths*.

Saving and Applying Changes

1. Click the **Save** button after applying changes to a page. This holds the new settings in the Apply Changes field.
2. After all desired changes have been made, click the flashing **Apply Changes** button, at the bottom of the left menu, to review the new settings. Click **Apply** to make the changes or **Revert** to cancel the changes.

Note: Settings take affect after the progress bar completes 100%.

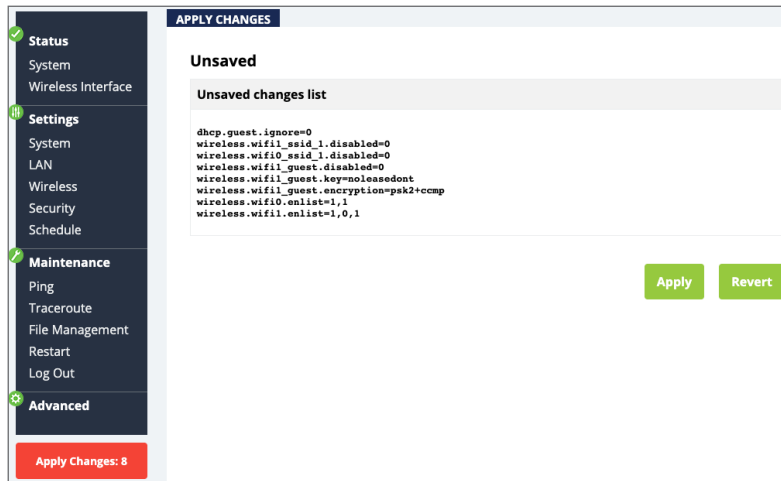

The screenshot displays the Araknis Networks web interface. On the left is a dark sidebar menu with categories: Status (checked), Settings (flashing), Maintenance (checked), and Advanced (plus icon). A red button at the bottom of the sidebar reads 'Apply Changes: 8'. The main content area is titled 'APPLY CHANGES' and contains an 'Unsaved' section with a list of configuration parameters:

```
dhcp.guest.ignore=0
wireless.wifi1 ssid.1.disabled=0
wireless.wifi0 ssid.1.disabled=0
wireless.wifi1.guest.disabled=0
wireless.wifi1.guest.key=noleasedont
wireless.wifi1.guest.encryption=psk2+ccmp
wireless.wifi0.enlist=1,1
wireless.wifi1.enlist=1,0,1
```

At the bottom right of the 'Unsaved' section are two green buttons: 'Apply' and 'Revert'.

Other Access Methods: DHCP IP Address

The WAP is configured to DHCP by default so that the DHCP server can assign an IP address when the WAP is connected to the network (the DHCP server is usually the router). This address can be used for accessing the web interface.

Use one of these methods to find the IP address of the WAP:

- Check the device list in OvrC
- Check the client table on your router
- Use a network scanner (e.g. Fing) to scan the network. The Araknis WAP manufacturer field displays **SnapAV**
- See the highlighted field in the Fing screenshot to the right for an example of an Araknis device being identified

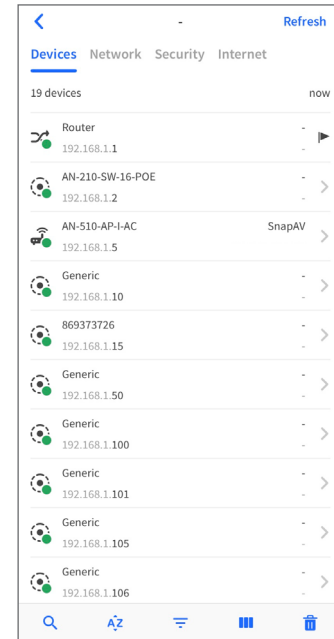

Other Access Methods: Default IP Address

If the WAP is not given an IP address on the network, or needs to be accessed while not connected to a network, you can configure your computer's network connection to access the WAP using the default IP address, **192.168.20.253**.

Windows 10 screenshots shown for reference.

1. Connect your PC to the WAP using an Ethernet cable.
2. Open the Control Panel and click **Network and Internet**.
3. Click **Network and Sharing Center**.

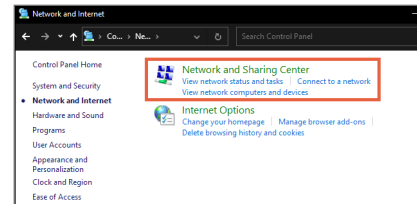
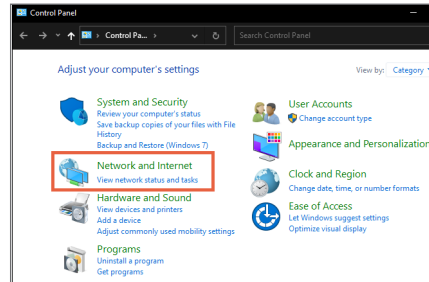
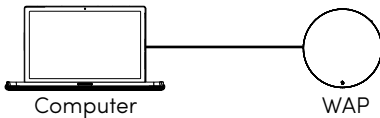

Windows 10 screenshots shown for reference.

4. Click **Change adapter settings**.

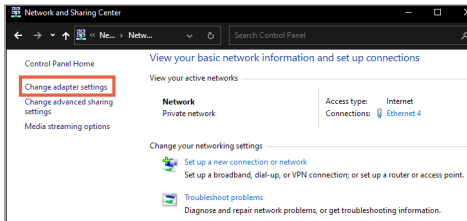

5. Right-click the icon for the wired network connection, then left-click **Properties**.

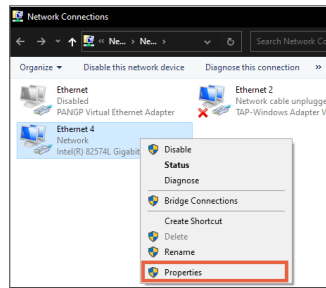

6. Select **Internet Protocol Version 4 (TCP/IPv4)**, then click **Properties**.

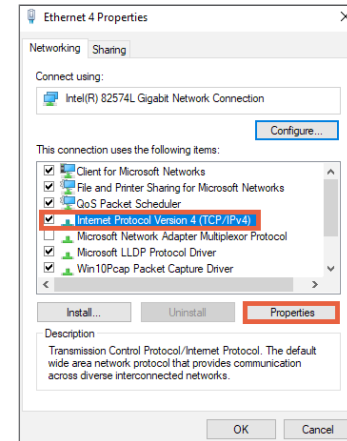

Windows 10 screenshots shown for reference.

7. In the **General** tab, click **Use the following IP address:** and enter the IP address and subnet mask, then click **OK**.

IP Address	192.168.20.2
Subnet Mask	255.255.255.0

8. Open a browser and navigate to **http://192.168.20.253/**. Log in using the default credentials:

Username	araknis
Password	araknis

9. Set the IPv4 Properties back to **Obtain an IP address automatically**, then click **OK**.

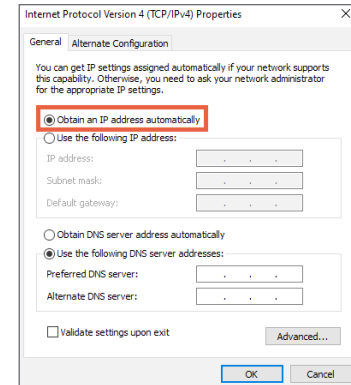
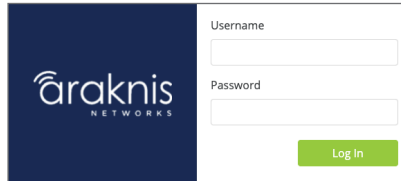
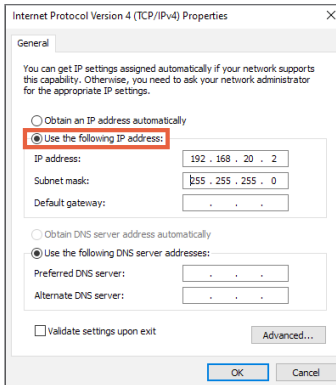

Technical Support

For chat and telephone, visit tech.control4.com/s/contactsupport • Email: TechSupport@SnapOne.com. Visit tech.control4.com for discussions, instructional videos, news, and more.

Warranty and Legal Notices

Find details of the product's Limited Warranty at snapone.com/legal/ or request a paper copy from Customer Service at 866.424.4489. Find other legal resources, such as regulatory notices and patent and safety information, at snapone.com/legal/.

Copyright ©2022, Snap One, LLC. All rights reserved. Snap One its respective logos are registered trademarks or trademarks of Snap One, LLC (formerly known as Wirepath Home Systems, LLC), in the United States and/or other countries. 4Store, 4Sight, Control4, Control4 My Home, SnapAV, Araknis Networks, and OvrC are also registered trademarks or trademarks of Snap One, LLC. Other names and brands may be claimed as the property of their respective owners. Snap One makes no claim that the information contained herein covers all installation scenarios and contingencies, or product use risks. Information within this specification subject to change without notice. All specifications subject to change without notice.

Version 220113

Part # 200-blah-blah

18

Electrical Safety Advisory
Sécurité électrique consultatif

Important Safety Instructions

Consignes de sécurité importantes

Read the safety instructions before using this product.

Lisez les consignes de sécurité avant d'utiliser ce produit.

1. Read these instructions.
Lisez ces instructions.
2. Keep these instructions.
Conservez ces instructions.
3. Heed all warnings.
Respectez tous les avertissements.
4. Follow all instructions.
Suivez toutes les instructions.
5. Do not use this apparatus near water.
Ne pas utiliser cet appareil près de l'eau.
6. Clean only with dry cloth.
Nettoyez-le uniquement avec un chiffon sec.
7. Do not block any ventilation openings. Install in accordance with the manufacturer's instructions.
Ne pas bloquer les ouvertures de ventilation. Installer conformément aux instructions du fabricant.
8. Do not install near any heat sources such as radiators, heat registers, stoves, or other apparatus (including amplifiers) that produce heat.
Ne pas installer près de sources de chaleur telles que des radiateurs, registres de chaleur, poêles, ou autres appareils (incluant les amplificateurs) qui produisent de la chaleur.
9. Only use attachments/accessories specified by the manufacturer.
Utilisez uniquement des fixations / accessoires spécifiés par le fabricant.
10. Use only with the cart, stand, tripod, bracket, or table specified by the manufacturer, or sold with the apparatus. When a cart is used, use caution when moving the cart/apparatus combination to avoid injury from tip-over.
Utilisez uniquement avec le chariot, le socle, le trépied, le support ou la table spécifiés par le fabricant ou vendu avec l'appareil. Lorsque vous utilisez un chariot, soyez prudent lorsque vous déplacez l'ensemble chariot / appareil pour éviter des blessures dues au renversement.



11. Refer all servicing to qualified service personnel. Servicing is required when the apparatus has been damaged in any way, such as power-supply cord or plug is damaged, liquid has been spilled or objects have fallen into the apparatus, the apparatus has been exposed to rain or moisture, does not operate normally, or has been dropped.

Confiez toutes les réparations à un personnel qualifié. Une réparation est nécessaire lorsque l'appareil a été endommagé de quelque façon que ce soit le cordon d'alimentation ou la fiche est endommagé, du liquide a été renversé ou si des objets sont tombés dans l'appareil, l'appareil a été exposé à la pluie ou à l'humidité, ne fonctionne pas normalement, ou s'il est tombé.

12. Protect the power cord from being walked on or pinched particularly at plugs, convenience receptacles, and the point where they exit from the apparatus.

Protégez le cordon d'alimentation ne soit piétiné ou pincé, en particulier au niveau des fiches, des prises et au point où il sort de l'appareil.

13. This equipment uses AC power which can be subjected to electrical surges, typically lightning transients which are very destructive to customer terminal equipment connected to AC power sources. The warranty for this equipment does not cover damage caused by electrical surge or lightning transients. To reduce the risk of this equipment becoming damaged it is suggested that the customer consider installing a surge arrester. Unplug this apparatus during lightning storms or when unused for long periods of time.

Cet équipement utilise la puissance AC qui peuvent être soumis à des surtensions électriques, la foudre généralement transitoires qui sont très destructives envers les équipements terminaux connectés à des sources d'alimentation CA. La garantie de cet appareil ne couvre pas les dommages causés par les surtensions électriques ou transitoires de foudre. Pour réduire le risque de cet équipement devient endommagé, il est suggéré que le client envisager l'installation d'un limiteur de surtension. Débranchez cet appareil pendant les orages ou lorsqu'il n'est pas utilisé pendant de longues périodes de temps.

14. To completely disconnect unit power from the AC mains, remove the power cord from the appliance coupler and/or turn off the circuit breaker. To reconnect power, turn on the circuit breaker following all safety instructions and guidelines. The circuit breaker shall remain readily accessible.

Pour débrancher complètement l'alimentation secteur du réseau secteur, retirez le cordon d'alimentation du coupleur de l'appareil et / ou éteignez le disjoncteur. Pour reconnecter l'alimentation, allumez le disjoncteur en suivant toutes les consignes et consignes de sécurité. Le disjoncteur doit être facilement accessible.

15. This product relies on the buildings installation for short-circuit (overcurrent) protection. Ensure that the protective device is rated not greater than: 20A.

Ce produit repose sur l'installation des bâtiments pour les courts-circuits (surintensité) de protection. Assurez-vous que le dispositif de protection est assignée ne dépassant pas: 20A.

16. **WARNING – Power Sources, Grounding, Polarization**

This product requires a properly grounded outlet for safety. This plug is designed to be inserted into a NEMA 5-15 (three-prong grounded) outlet only. Do not force the plug into an outlet that is not designed to accept it. Never dismantle the plug or alter the power cord, and do not attempt to defeat the grounding feature by using a 3-to-2 prong adapter. If you have a question about grounding, consult your local power company or qualified electrician.

If a rooftop device such as a satellite dish connect to the product, ensure that the devices' wires are also properly grounded.

The bonding point can be used to provide a common ground to other equipment. This bonding point can accommodate minimum 12 AWG wire and should be connected using the required hardware specified by the other bonding point. Please use termination for your equipment in accordance with the applicable local agency requirements.

AVERTISSEMENT - Sources d'alimentation, mise à la terre, polarisation

Ce produit nécessite une prise correctement mise à la terre pour des raisons de sécurité. Cette fiche est conçue pour être insérée dans une prise NEMA 5-15 (trois broches mise à la terre) uniquement. Ne forcez pas la fiche dans une prise qui n'est pas conçue pour l'accepter. Ne démontez jamais la fiche ou ne modifiez pas le cordon d'alimentation, et n'essayez pas de désactiver la fonction de mise à la terre en utilisant un adaptateur 3 à 2 broches. Si vous avez une question sur la mise à la terre, consultez votre compagnie d'électricité locale ou un électricien qualifié.

Si un appareil sur le toit tel qu'une antenne parabolique se connecte au produit, assurez-vous que les fils des appareils sont également correctement mis à la terre.

Le point de liaison peut être utilisé pour fournir une masse commune à d'autres équipements. Ce point de connexion peut accueillir un fil de 12 AWG minimum et doit être connecté à l'aide du matériel requis spécifié par l'autre point de connexion. Veuillez utiliser une terminaison pour votre équipement conformément aux exigences des agences locales applicables.

17. Notice – For indoor use only, Internal components are not sealed from the environment. The device can only be used in a fixed location such as a telecommunication center, or a dedicated computer room. When you install the device, ensure that the protective earthing connection of the socket-outlet is verified by a skilled person. Suitable for installation in information technology rooms in accordance with Article 645 of the National Electrical Code and NFP 75.

Avis – Pour une utilisation en intérieur uniquement, les composants internes ne sont pas scellés de l'environnement. L'appareil ne peut être utilisé que dans un lieu fixe tel qu'un centre de télécommunication, ou une salle informatique dédiée. Lors de l'installation de l'appareil, assurez-vous que la mise à la terre de protection de la prise de courant est vérifiée par une personne qualifiée. Convient pour une installation dans des salles informatiques conformément à l'article 645 du Code national de l'électricité et NFP 75.

18. This product can interfere with electrical equipment such as tape recorders, TV sets, radios, computers, and microwave ovens if placed in close proximity.

Ce produit peut interférer avec des appareils électriques tels que les magnétophones, téléviseurs, radios, ordinateurs et fours à micro-ondes si placés à proximité.

19. Never push objects of any kind into this product through cabinet slots as they may touch dangerous voltage points or short out parts that could result in fire or electric shock.

N'introduisez jamais d'objets d'aucune sorte dans ce produit à travers les fentes du boîtier car ils pourraient toucher des points de tension dangereux ou court-circuiter des pièces qui pourraient entraîner un incendie ou un choc électrique.

20. **WARNING** – No user serviceable parts inside. If the product is not operating properly, do not remove any part of the unit (cover, etc.) for repair. Unplug the unit and consult the warranty section of the owner's manual.

AVERTISSEMENT – Aucune pièce réparable par l'utilisateur à l'intérieur. Si le produit ne fonctionne pas correctement, ne retirez aucune pièce de l'appareil (couvercle, etc.) pour réparation. Débranchez l'appareil et consultez la section de garantie du manuel du propriétaire.

21. **CAUTION:** As with all batteries, there is a risk of explosion or personal injury if the battery is replaced by an incorrect type. Dispose of used battery according to the instructions of the battery manufacturer and applicable environmental guidelines. Do not open, puncture or incinerate the battery, or expose it to conducting materials, moisture, liquid, fire or heat above 54° C or 130° F.

ATTENTION: Comme avec toutes les batteries, il ya un risque d'explosion ou de blessure si la batterie est remplacée par un type incorrect. Éliminez les batteries usagées selon les instructions du fabricant de la batterie et applicables des directives environnementales. Ne pas ouvrir, percer ou incinérer la batterie, ou de l'exposer à des matériaux conducteurs, de l'humidité, du liquide, un incendie ou une température supérieure à 54 ° C ou 130 ° F.

22. PoE considered a Network Environment 0 per IEC TR62101, and thus the interconnected ITE circuits may be considered ES1. The installation instructions clearly state that the ITE is to be connected only to PoE networks without routing to the outside plant.

PoE considéré comme un environnement de réseau 0 selon IEC TR62101 et, par conséquent, les circuits ITE interconnectés peuvent être considérés comme ES1. Les instructions d'installation indiquent clairement que l'ITE doit être connecté uniquement aux réseaux PoE sans acheminement vers l'installation externe.



The lightning flash and arrow head within the triangle is a warning sign alerting you of dangerous voltage inside the product
L'éclair et la flèche dans le triangle est un signe d'alerte pour vous avertir d'une tension dangereuse à l'intérieur du produit



Caution: To reduce the risk of electric shock, do not remove cover (or back). No user serviceable parts inside. Refer servicing to qualified service personnel.

Attention: Pour réduire le risque de choc électrique, ne pas retirer le couvercle (ou l'arrière). Aucune pièce réparable par l'utilisateur. Confiez l'entretien à un personnel qualifié.



The exclamation point within the triangle is a warning sign alerting you of important instructions accompanying the product.

Le point d'exclamation dans un triangle est un signe d'avertissement vous signale des instructions importantes accompagnant le produit.

See marking on bottom / back of product

Voir le marquage sur les bas / dos du produit



Warning!: To reduce the risk of electrical shock, do not expose this apparatus to rain or moisture

AVERTISSEMENT! Pour réduire le risque de choc électrique, n'exposez pas cet appareil à la pluie ou à l'humidité.

Save these instructions
Conservez ces instructions

USA & Canada Compliance

FCC Part 15, Subpart B Unintentional Emissions Interference Statement

This equipment has been tested and found to comply with the limits for a Class B digital device, pursuant to Part 15 of the FCC rules. These limits are designed to provide reasonable protection against harmful interference when the equipment is operated in a residential installation. This equipment generates uses and can radiate radio frequency energy and, if not installed and used in accordance with the instructions, may cause harmful interference to radio communications. However, there is no guarantee that interference will not occur in a particular installation. If this equipment does cause harmful interference to radio or television reception, which can be determined by turning the equipment off and on, the user is encouraged to try to correct the interference by one or more of the following measures:

- Reorient or relocate the receiving antenna.
- Increase the separation between the equipment and receiver.
- Connect the equipment into an outlet on a circuit different from that to which the receiver is connected.
- Consult the dealer or an experienced radio/TV technician for help.

This device complies with part 15 of the FCC rules. Operation is subject to the following two conditions: (1) This device may not cause harmful interference, and (2) this device must accept any interference received, including interference that may cause undesired operation.

IMPORTANT! Any changes or modifications not expressly approved by the party responsible for compliance could void the user's authority to operate this equipment.

Innovation Science and Economic Development (ISED) Unintentional Emissions Interference Statement

CAN ICES-3 (B)/NMB-3(B)

This device contains licence-exempt transmitter(s)/receiver(s) that comply with Innovation, Science and Economic Development Canada's licence-exempt RSS(s). Operation is subject to the following two conditions:

- (1) This device may not cause interference
- (2) This device must accept any interference, including interference that may cause undesired operation of the device

L'émetteur/récepteur exempt de licence contenu dans le présent appareil est conforme aux CNR d'Innovation, Sciences et Développement économique Canada applicables aux appareils radio exempts de licence. L'exploitation est autorisée aux deux conditions suivantes :

- (1) L'appareil ne doit pas produire de brouillage;
- (2) L'appareil doit accepter tout brouillage radioélectrique subi, même si le brouillage est susceptible d'en compromettre le fonctionnement.

FCC Part 15, Subpart C / RSS-247 Intentional Emissions Interference Statement

Compliance of this equipment is confirmed by the following certification numbers that are placed on the equipment:



Notice: The term “FCC ID:” and “IC:” before the certification number signifies that FCC and Industry Canada technical specifications were met.

FCC ID: 2AJAC-AN520API
IC: 7848A-AN520API

This equipment must be installed by qualified professionals or contractors in accordance with FCC Part 15.203 & IC RSS-247, Antenna Requirements. Do not use any antenna other than the one provided with the unit.

Professional installation instruction

Please be advised that due to the unique function supplied by this product, the device is intended for use with our interactive entertainment software and licensed third-party only. The product will be distributed through controlled distribution channel and installed by trained professional and will not be sold directly to the general public through retail store.

1. Installation personal

This product is designed for specific application and needs to be installed by a qualified personal who has RF and related rule knowledge. The general user shall not attempt to install or change the setting.

2. Installation location

The product shall be installed at a location where the radiating antenna can be kept 20cm from nearby person in normal operation condition to meet regulatory RF exposure requirement.

3. Installation procedure

Please refer to user’s manual for the detail.

4. Warning

Please carefully select the installation position and make sure that the final output power does not exceed the limit set force in relevant rules. The violation of the rule could lead to serious federal penalty.

Caution:

(i) the device for operation in the band 5150–5250 MHz is only for indoor use to reduce the potential for harmful interference to co-channel mobile satellite systems;

(ii) for devices with detachable antenna(s), the maximum antenna gain permitted for devices in the bands 5250-5350 MHz and 5470-5725 MHz shall be such that the equipment still complies with the e.i.r.p. limit;

(iii) for devices with detachable antenna(s), the maximum antenna gain permitted for devices in the band 5725-5850 MHz shall be such that the equipment still complies with the e.i.r.p. limits as appropriate

Operations in the 5.25-5.35GHz band are restricted to indoor usage only.

Avertissement:

(i) les dispositifs fonctionnant dans la bande de 5 150 à 5 250 MHz sont réservés uniquement pour une utilisation à l'intérieur afin de réduire les risques de brouillage préjudiciable aux systèmes de satellites mobiles utilisant les mêmes canaux;

(ii) pour les dispositifs munis d'antennes amovibles, le gain maximal d'antenne permis pour les dispositifs utilisant les bandes de 5 250 à 5 350 MHz et de 5 470 à 5 725 MHz doit être conforme à la limite de la p.i.r.e;

(iii) pour les dispositifs munis d'antennes amovibles, le gain maximal d'antenne permis (pour les dispositifs utilisant la bande de 5 725 à 5 850 MHz) doit être conforme à la limite de la p.i.r.e. spécifiée, selon le cas;

Les opérations dans la bande de 5.25-5.35GHz sont limités à un usage intérieur seulement.

FCC Partie 15, sous-partie C / RSS-247 Déclaration volontaire des émissions interférences

Conformité de cet appareil est confirmé par les chiffres de certification suivants qui sont placés sur l'équipement:

Avis: Le terme «FCC ID:" et "IC:" devant le numéro de certification signifie que les spécifications techniques de la FCC et d'Industrie Canada ont été respectées.

FCC ID: 2AJAC-AN520API
IC: 7848A-AN520API

Cet équipement doit être installé par des professionnels qualifiés ou entrepreneurs conformément aux normes FCC partie 15.203 & IC RSS-247, Exigences d'antenne. Ne pas utiliser une antenne autre que celui fourni avec l'appareil.

Cet émetteur ne doit pas être localisé ou fonctionner avec d'autres antennes ou transmetteurs. Les opérations dans la bande 5.15-5.25GHz sont limitées à l'utilisation à l'intérieur seulement.

Instructions d'installation professionnelle

Veillez noter que l'appareil étant dédié à une fonction unique, il doit être utilisé avec notre logiciel propriétaire de divertissement interactif. Ce produit sera proposé par un réseau de distribution contrôlé et installé par des professionnels; il ne sera pas proposé au grand public par le réseau de la grande distribution.

1. Installation

Ce produit est destiné à un usage spécifique et doit être installé par un personnel qualifié maîtrisant les radiofréquences et les règles s'y rapportant. L'installation et les réglages ne doivent pas être modifiés par l'utilisateur final.

2. Emplacement d'installation

En usage normal, afin de respecter les exigences réglementaires concernant l'exposition aux radiofréquences, ce produit doit être installé de façon à respecter une distance de 20 cm entre l'antenne émettrice et les personnes.

3. Procédure d'installation

Consulter le manuel d'utilisation.

4. Avertissement

Choisir avec soin la position d'installation et s'assurer que la puissance de sortie ne dépasse pas les limites en vigueur. La violation de cette règle peut conduire à de sérieuses pénalités fédérales.

Avertissement:

(i) les dispositifs fonctionnant dans la bande 5150-5250 MHz sont réservés uniquement pour une utilisation à l'intérieur afin de réduire les risques de brouillage préjudiciable aux systèmes de satellites mobiles utilisant les mêmes canaux;

(ii) le gain maximal d'antenne permis (pour les dispositifs utilisant la bande de 5725 à 5850 MHz) doit être conforme à la limite de la p.i.r.e. spécifiée pour l'exploitation point à point et l'exploitation non point à point, selon le cas;

(iii) De plus, les utilisateurs devraient aussi être avisés que les utilisateurs de radars de haute puissance sont désignés utilisateurs principaux (c.-à-d., qu'ils ont la priorité) pour les bandes 5650-5850 MHz et que ces radars pourraient causer du brouillage et/ou des dommages aux dispositifs LAN-EL.

RF Radiation Exposure Statement

This equipment complies with FCC RF and Canada radiation exposure limits set forth for an uncontrolled environment. This equipment should be installed and operated with a minimum distance of 20 centimeters between the radiator and your body or nearby persons.

This transmitter must not be co-located or operating in conjunction with any other antenna or transmitter.

Country Code selection feature to be disabled for products marketed to the US/CANADA.

Déclaration d'exposition aux radiations RF

Cet équipement est conforme aux limites d'exposition aux rayonnements RF et IC de la FCC définies pour un environnement non contrôlé. Cet équipement doit être installé et utilisé avec une distance minimale de 20 centimètres entre le radiateur et votre corps ou des personnes proches.

Cet émetteur ne doit pas être co-localisé ou fonctionner en conjonction avec une autre antenne ou un autre émetteur.

La fonction de sélection du code de pays doit être désactivée pour les produits commercialisés aux États-Unis.

Europe Compliance

Compliance of this equipment is confirmed by the following logo that is placed on the product ID label that is placed on the bottom of the equipment. The full text of the EU Declaration of Conformity (DoC) is available on the regulatory webpage:



This product can be put into service in all of the EU member states, European Free Trade Association (EFTA) and EU candidate countries without any restriction.



BE	BG	CZ	DK
DE	EE	IE	EL
ES	FR	HR	IT
CY	LV	LT	LU
HU	MT	NL	AT
PL	PT	RO	SI
SK	FI	SE	UK
IS	LI	NO	CH
MK	AL	RS	TR

The frequency and maximum transmitted power in EU are listed as below:

2412~2472MHz : 19.35 dBm

5180~5240MHz : 22.44 dBm

5260~5320MHz : 22.47 dBm

5500~5700MHz : 29.10 dBm

WLAN 5GHz:

Operations in the 5.15-5.35GHz band are restricted to indoor usage only.

United Kingdom (UK) Compliance

Compliance of this equipment is confirmed by the following logo that is placed on the product ID label that is placed on the bottom of the equipment. The full text of the UK Declaration of Conformity (DoC) is available on the regulatory webpage:



Recycling

Snap One understands that a commitment to the environment is essential for a health life and sustainable growth for future generations. We are committed to supporting the environmental standards, laws, and directives that have been put in place by various communities and countries that deal with concerns for the environment. This commitment is represented by combining technological innovation with sound environmental business decisions.

WEEE Compliance

Snap One is committed to meeting all requirements of the Waste Electrical and Electronic Equipment (WEEE) directive (2012/19/EC). The WEEE directive requires the manufacturers of electrical and electronic equipment who sell in EU countries: (1) label their equipment to notify

customers that it needs to be recycled, and (2) provide a way for their products to be appropriately disposed of or recycled at the end of their product lifespan. For collection or recycling of Snap One products, please contact your local Snap One representative or dealer.



Australia & New Zealand Compliance

Compliance of this equipment is confirmed by the following logo that is placed on the product ID label that is placed on the bottom of the equipment.



About this Document

Copyright © 2021 Snap One All rights reserved.