

5.2G

B Antenna

802.11a 5180MHz



802.11n(HT20) 5180MHz



802.11a 5200MHz

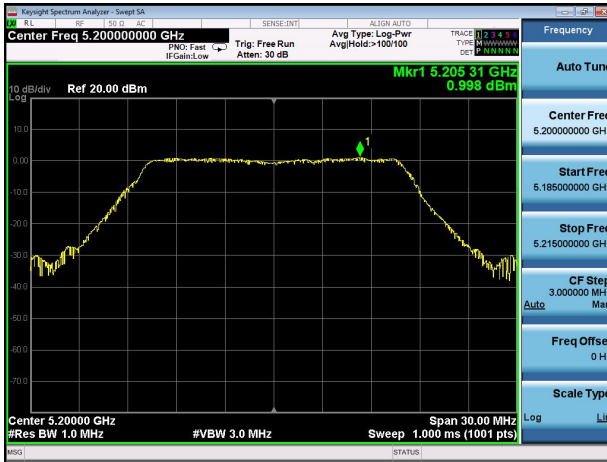

802.11n(HT20) 5200MHz

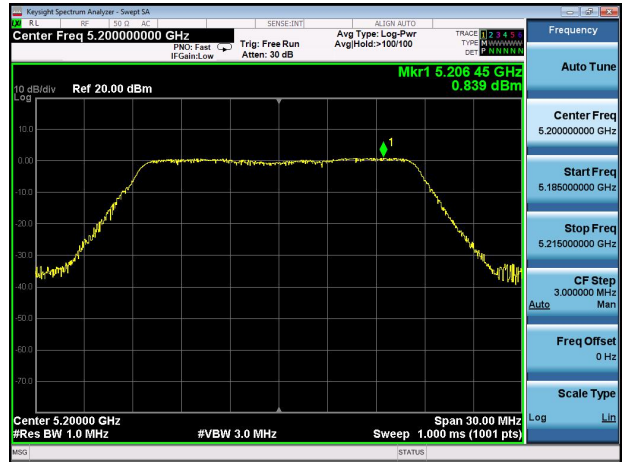

802.11a 5240MHz



802.11n(HT20) 5240MHz

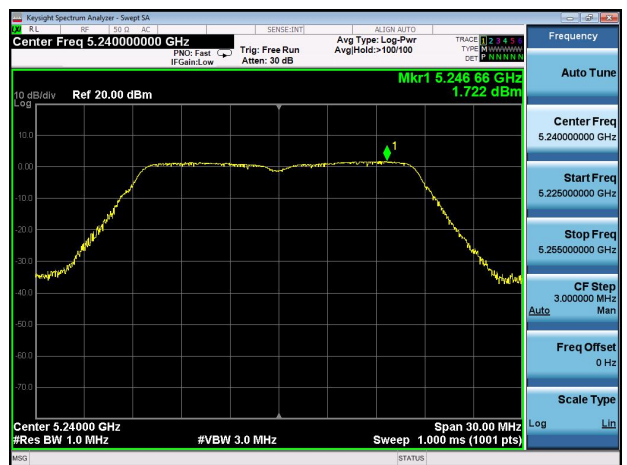

802.11n (HT40) 5190MHz



802.11n (HT40) 5230MHz



5.8G

A Antenna

802.11a 5745MHz



802.11n(HT20) 5745MHz

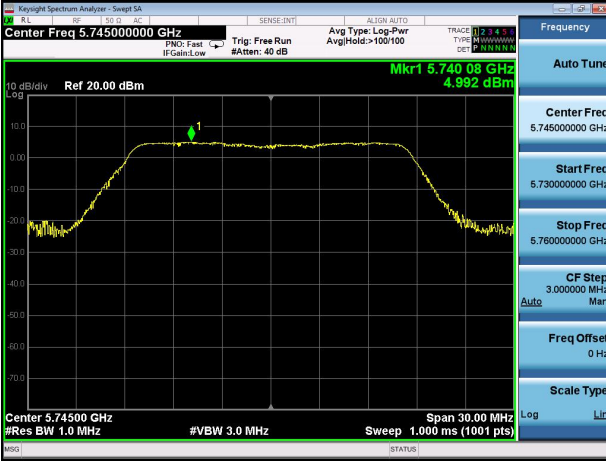

802.11a 5785MHz



802.11n(HT20) 5785MHz

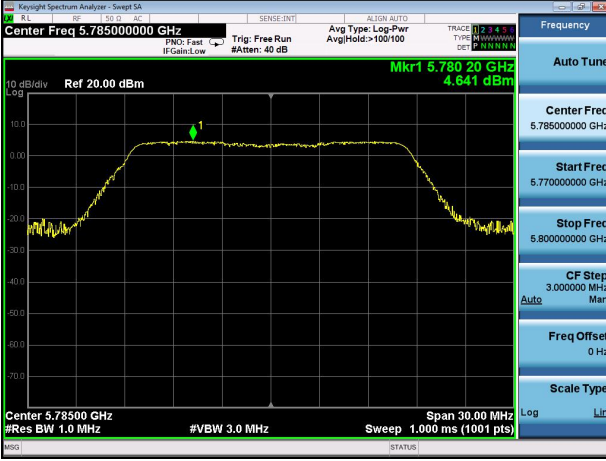

802.11a 5825MHz



802.11n(HT20) 5825MHz



802.11n (HT40) 5755MHz



802.11n (HT40) 5795MHz



5.8G

B Antenna

802.11a 5745MHz

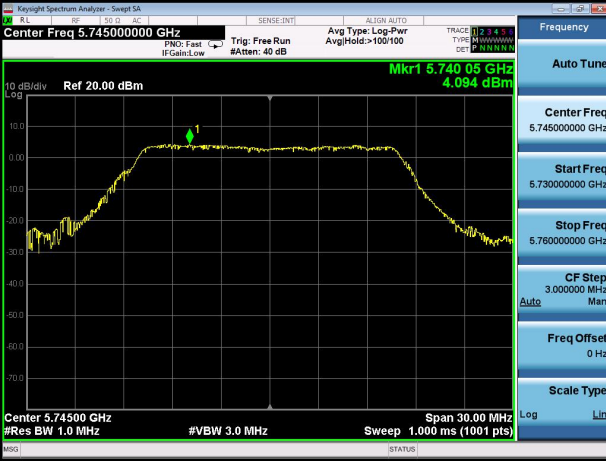

802.11n(HT20) 5745MHz



802.11a 5785MHz



802.11n(HT20) 5785MHz



802.11a 5825MHz



802.11n(HT20) 5825MHz



802.11n (HT40) 5755MHz



802.11n (HT40) 5795MHz



10. FREQUENCY STABILITY TEST

10.1. Limit

According to §15.407(g), manufacturers of U-NII devices are responsible for ensuring frequency stability such that an emission is maintained within the band of operation under all conditions of normal operation as specified in the user's manual.

10.2. Test Configuration

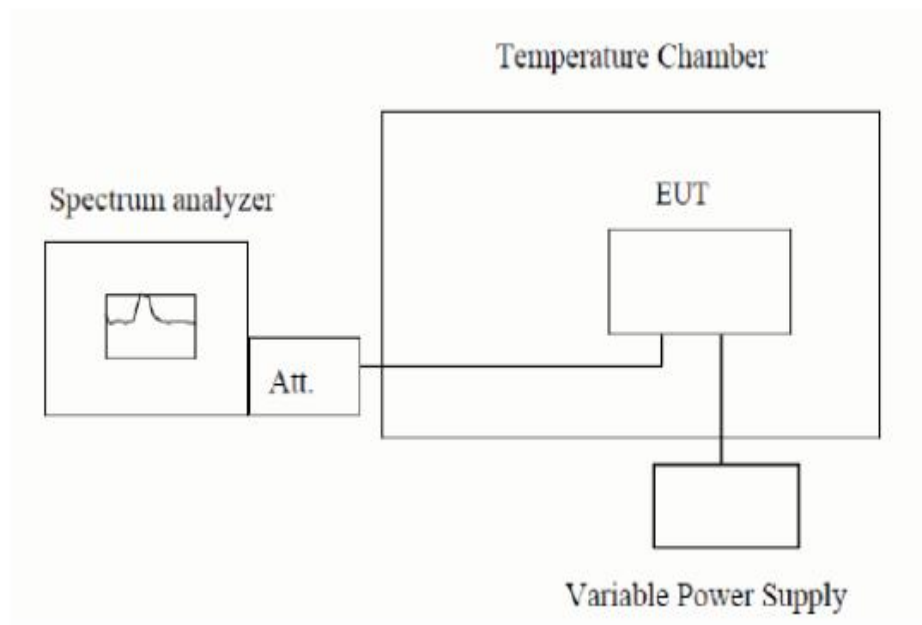

10.3. Test Procedure

1. The transmitter output (antenna port) was connected to the spectrum analyzer.
2. EUT have transmitted absence of modulation signal and fixed channelize.
3. Set the spectrum analyzer span to view the entire absence of modulation emissions bandwidth.
4. Set RBW = 10 kHz, VBW = 10 kHz with peak detector and max hold settings.
5. f_c is declaring of channel frequency. Then the frequency error formula is $(f_c - f) / f_c \times 10^6$ ppm and the limit is less than ± 20 ppm (IEEE 802.11 specification).
6. The test extreme voltage is to change the primary supply voltage from 85 to 115 percent of the nominal value
7. Extreme temperature rule is $-30^\circ\text{C} \sim 50^\circ\text{C}$.

10.4. Test result

Measurement Data : (the worst model was 802.11a)

Frequency Stability under Temperature

Operating Frequency: 5180 MHz				
Environment Temperature(oC)	Voltage(V)	Measured Frequency(MHz)	Test Result (MHz)	Max. Deviation (ppm)
50	120	5180	5180.0548	10.579
40	120	5180	5180.0652	12.587
30	120	5180	5180.0519	10.019
20	120	5180	5180.0542	10.463
10	120	5180	5180.0516	9.961
0	120	5180	5180.0653	12.606
-10	120	5180	5180.0545	10.521
-20	120	5180	5180.0672	12.973
-30	120	5180	5180.0548	10.579

Frequency Stability under Voltage

Operating Frequency: 5180 MHz			
DC Voltage(V)	Measured Frequency(MHz)	Test Result(MHz)	Max. Deviation(ppm)
108	5180	5180.0547	10.560
120	5180	5180.0519	10.019
132	5180	5180.0526	10.154

Frequency Stability under Temperature

Operating Frequency: 5200 MHz				
Environment Temperature(oC)	Voltage(V)	Measured Frequency(MHz)	Test Result (MHz)	Max. Deviation (ppm)
50	120	5200	5200.0612	11.769
40	120	5200	5200.0598	11.500
30	120	5200	5200.0586	11.269
20	120	5200	5200.0576	11.077
10	120	5200	5200.0563	10.827
0	120	5200	5200.0543	10.442
-10	120	5200	5200.0601	11.558
-20	120	5200	5200.0594	11.423
-30	120	5200	5200.0585	11.250

Frequency Stability under Voltage

Operating Frequency: 5200 MHz			
DC Voltage(V)	Measured Frequency(MHz)	Test Result(MHz)	Max. Deviation(ppm)
108	5200	5200.0488	9.385
120	5200	5200.0501	9.635
132	5200	5200.0531	10.212

Frequency Stability under Temperature

Operating Frequency: 5240 MHz				
Environment Temperature(oC)	Voltage(V)	Measured Frequency(MHz)	Test Result (MHz)	Max. Deviation (ppm)
50	120	5240	5240.0618	11.794
40	120	5240	5240.0598	11.412
30	120	5240	5240.0576	10.992
20	120	5240	5240.0582	11.107
10	120	5240	5240.0585	11.164
0	120	5240	5240.0607	11.584
-10	120	5240	5240.0623	11.889
-20	120	5240	5240.0605	11.546
-30	120	5240	5240.0597	11.393

Frequency Stability under Voltage

Operating Frequency: 5240 MHz			
DC Voltage(V)	Measured Frequency(MHz)	Test Result(MHz)	Max. Deviation(ppm)
108	5240	5240.0523	9.981
120	5240	5240.0497	9.485
132	5240	5240.0513	9.790

11. ANTENNA REQUIREMENTS

11.1.Limits

For intentional device, according to FCC 47 CFR Section 15.203, an intentional radiator shall be designed to ensure that no antenna other than that furnished by the responsible party shall be used with the device. And according to FCC 47 CFR Section 15.247 (b), if transmitting antennas of directional gain greater than 6dBi are used, the power shall be reduced by the amount in dB that the directional gain of the antenna exceeds 6dBi.

11.2.Result

The antenna used for this product is internal antenna and that no antenna other than that furnished by the responsible party shall be used with the device, the maximum peak gain of the transmit antenna is only 2.35dBi.

12. PHOTOGRAPHS OF TEST SET-UP

Conducted Emission



Radiated Emission Test

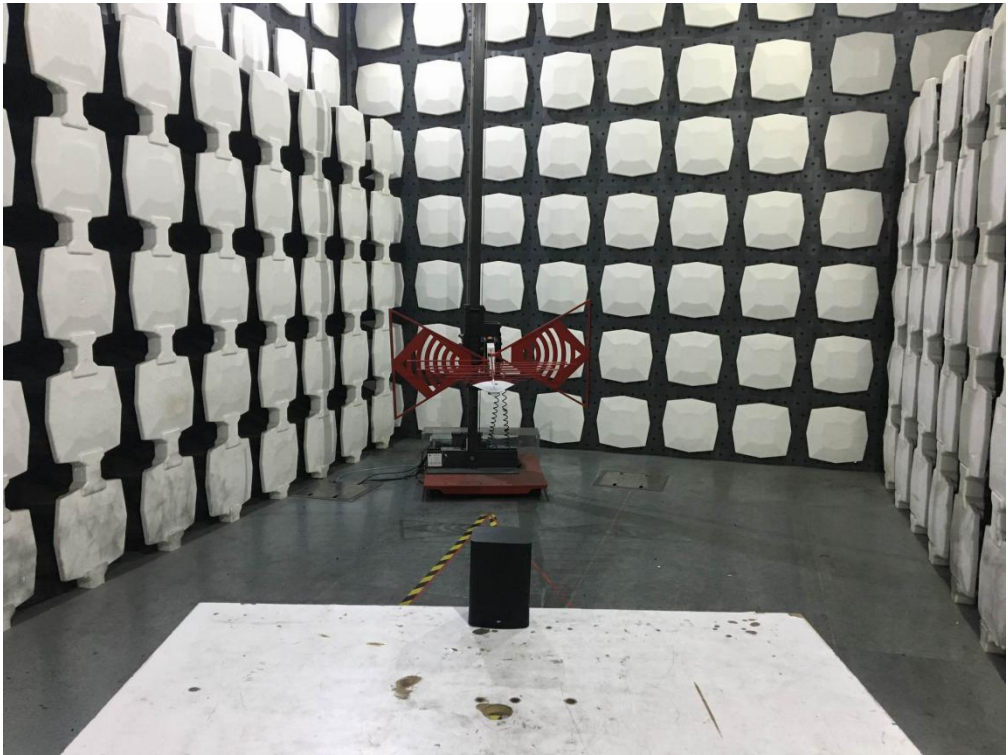

13. PHOTOGRAPHS OF THE EUT

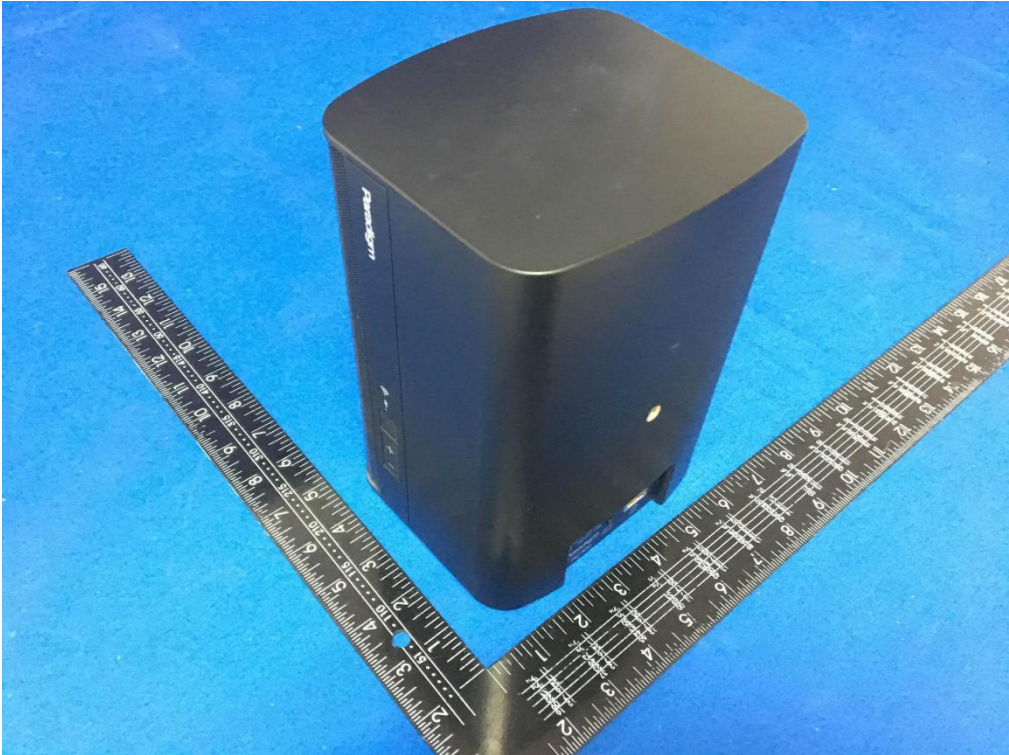
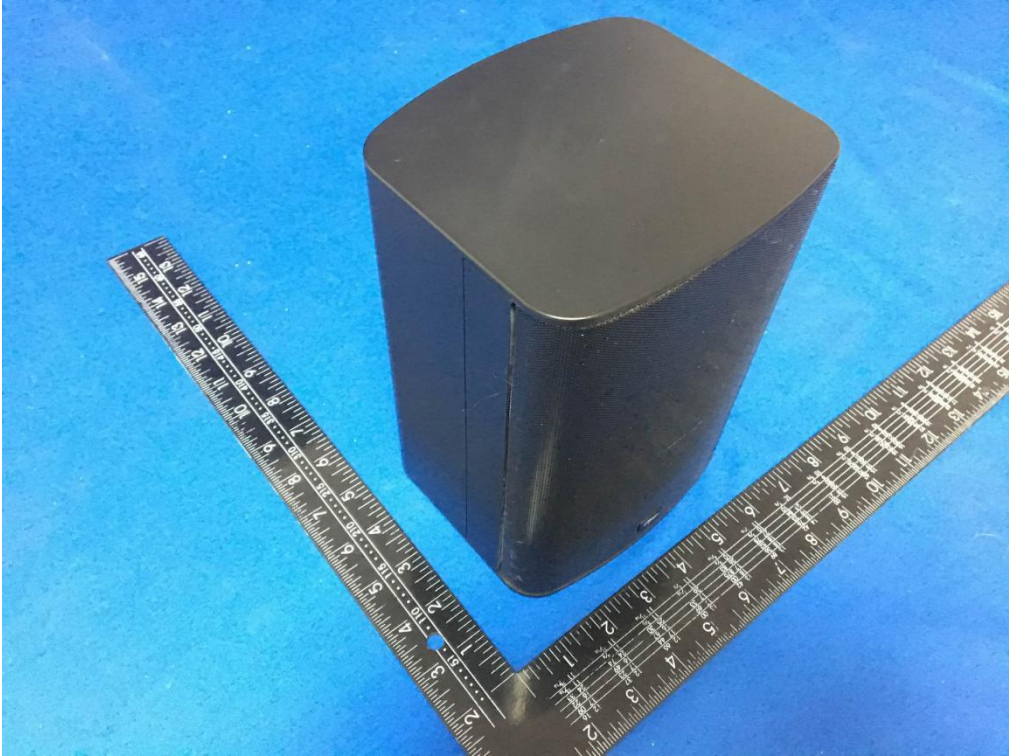



*** the end of report ***