

FCC Test Report

Product Name	STREAMING SOUNDBAR
Model No	AU-SNDBR-2.0-BLK
FCC ID.	2AJAAAUSNDBR20BLK

Applicant	DONGGUAN MEILOON ACOUSTIC EQUIPMENTS CO., LTD.
Address	77, Yuanlin Road, Fenghuanggang Ind. Estate, Tangxia Town, Guangdong Province, Dongguan City, 523727, China

Date of Receipt	Aug. 30, 2018
Issue Date	Dec. 20, 2018
Report No.	1880389R-RFUSP72V00-B
Report Version	V1.0



The test results relate only to the samples tested.

The test results shown in the test report are traceable to the national/international standard through the calibration report of the equipment and evaluated measurement uncertainty herein.

This report must not be used to claim product endorsement by TAF or any agency of the government.

The test report shall not be reproduced without the written approval of DEKRA Testing and Certification Co., Ltd.

Test Report

Issue Date: Dec. 20, 2018

Report No.: 1880389R-RFUSP72V00-B



Product Name	STREAMING SOUNDBAR
Applicant	DONGGUAN MEILOON ACOUSTIC EQUIPMENTS CO., LTD.
Address	77, Yuanlin Road, Fenghuanggang Ind. Estate, Tangxia Town, Guangdong Province, Dongguan City, 523727, China
Manufacturer	Wirepath Home Systems, LLC – doing business as SnapAV
Model No.	AU-SNDBR-2.0-BLK
FCC ID.	2AJAAAUSNDBR20BLK
EUT Rated Voltage	AC 100-240V, 50/60Hz
EUT Test Voltage	AC 120V/60Hz
Trade Name	AUTONOMIC
Applicable Standard	FCC CFR Title 47 Part 15 Subpart C: 2016 ANSI C63.4: 2014, ANSI C63.10: 2013 KDB 558074 D01 DTS Meas Guidance v05
Test Result	Complied

Documented By :

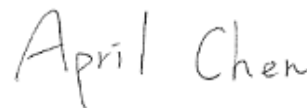

(Senior Adm. Specialist / April Chen)

Tested By :



(Engineer / Sam Hsu)

Approved By :



(Director / Vincent Lin)

TABLE OF CONTENTS

Description	Page
1. GENERAL INFORMATION	5
1.1. EUT Description.....	5
1.2. Operational Description	7
1.3. Tested System Details.....	8
1.4. Configuration of Tested System	8
1.5. EUT Exercise Software	9
1.6. Test Facility	10
1.7. List of Test Equipment	11
2. Conducted Emission.....	12
2.1. Test Setup	12
2.2. Limits	13
2.3. Test Procedure	13
2.4. Uncertainty	13
2.5. Test Result of Conducted Emission.....	14
3. Peak Power Output	20
3.1. Test Setup	20
3.2. Limits	20
3.3. Test Procedure	20
3.4. Uncertainty	20
3.5. Test Result of Peak Power Output.....	21
4. Radiated Emission.....	25
4.1. Test Setup	25
4.2. Limits	26
4.3. Test Procedure	27
4.4. Uncertainty	28
4.5. Test Result of Radiated Emission.....	29
5. RF antenna conducted test.....	69
5.1. Test Setup	69
5.2. Limits	69
5.3. Test Procedure	69
5.4. Uncertainty	69
5.5. Test Result of RF antenna conducted test.....	70
6. Band Edge	74
6.1. Test Setup	74
6.2. Limits	74
6.3. Test Procedure	74
6.4. Uncertainty	75
6.5. Test Result of Band Edge	76
7. 6dB Bandwidth	92
7.1. Test Setup	92
7.2. Limits	92

7.3.	Test Procedure	92
7.4.	Uncertainty	92
7.5.	Test Result of 6dB Bandwidth.....	93
8.	Power Density	101
8.1.	Test Setup	101
8.2.	Limits	101
8.3.	Test Procedure	101
8.4.	Uncertainty	101
8.5.	Test Result of Power Density	102
9.	Duty Cycle	110
9.1.	Test Setup	110
9.2.	Test Procedure	110
9.3.	Uncertainty	110
9.4.	Test Result of Duty Cycle.....	111
10.	EMI Reduction Method During Compliance Testing	114
Attachment 1: EUT Test Photographs		
Attachment 2: EUT Detailed Photographs		

1. GENERAL INFORMATION

1.1. EUT Description

Product Name	STREAMING SOUNDBAR
Trade Name	AUTONOMIC
Model No.	AU-SNDBR-2.0-BLK
FCC ID.	2AJAAAUSNDBR20BLK
Frequency Range	2412-2462MHz for 802.11b/g/n-20BW, 2422-2452MHz for 802.11n-40BW
Number of Channels	802.11b/g/n-20MHz: 11, n-40MHz: 7
Data Speed	802.11b: 1-11Mbps, 802.11g: 6-54Mbps, 802.11n: up to 150Mbps
Type of Modulation	802.11b:DSSS (DBPSK, DQPSK, CCK) 802.11g/n:OFDM (BPSK, QPSK, 16QAM, 64QAM)
Antenna Type	PIFA Antenna
Antenna Gain	Refer to the table "Antenna List"
Channel Control	Auto
RCA Cable	Non-shielded,1.5m
Fiber Cable	Non-shielded,1.5m
Power Adapter #1	MFR: Dongguan Dongsong Electronic Co., Ltd, M/N: DYS602-240250-15714A Input: AC 100-240V~50-60Hz 1.5A MAX Output: 24.0V $\overline{=}$ 2.5A Cable out: Non-Shielded, 1.8m with one ferrite core bonded. Power cord: Non-Shielded, 1.8m.
Power Adapter #2	MFR: EPS, M/N: F150602-A Input: AC 100-240V~1.8A 50-60Hz Output: 24V $\overline{=}$ 2.5A Cable out: Non-Shielded, 1.8m with one ferrite core bonded. Power cord: Non-Shielded, 1.8m.

Antenna List

No.	Manufacturer	Part No.	Antenna Type	Peak Gain
1	Taiwan Anjie	AJDP1J-B0019	PIFA	3.6 dBi for 2.4 GHz

Note:

1. The antenna of EUT conforms to FCC 15.203.

802.11b/g/n-20MHz Center Frequency of Each Channel:

Channel	Frequency	Channel	Frequency	Channel	Frequency	Channel	Frequency
Channel 01:	2412 MHz	Channel 02:	2417 MHz	Channel 03:	2422 MHz	Channel 04:	2427 MHz
Channel 05:	2432 MHz	Channel 06:	2437 MHz	Channel 07:	2442 MHz	Channel 08:	2447 MHz
Channel 09:	2452 MHz	Channel 10:	2457 MHz	Channel 11:	2462 MHz		

802.11n-40MHz Center Frequency of Each Channel:

Channel	Frequency	Channel	Frequency	Channel	Frequency	Channel	Frequency
Channel 03:	2422 MHz	Channel 04:	2427 MHz	Channel 05:	2432 MHz	Channel 06:	2437 MHz
Channel 07:	2442 MHz	Channel 08:	2447 MHz	Channel 09:	2452 MHz		

Note:

1. The EUT is a STREAMING SOUNDBAR with a built-in WLAN, Bluetooth and 5.8GHz transceiver transceiver, this report for WLAN.
2. Regarding to the operation frequency, the lowest, middle and highest frequency are selected to perform the test.
3. Lowest and highest data rates are tested in each mode. Only worst case is shown in the report. (802.11b is 1Mbps 、802.11g is 6Mbps 、802.11n(20M-BW) is 7.2Mbps and 802.11n(40M-BW) is 15Mbps)
4. These tests are conducted on a sample for the purpose of demonstrating compliance of 802.11b/g/n transmitter with Part 15 Subpart C Paragraph 15.247 of spread spectrum devices.
5. The radiation measurements are performed in X, Y, Z axis positioning. Only the worst case is shown in the report.

Test Mode:	Mode 1: Transmit (802.11b 1Mbps)
	Mode 2: Transmit (802.11g 6Mbps)
	Mode 3: Transmit (802.11n MCS0 7.2Mbps 20M-BW)
	Mode 4: Transmit (802.11n MCS0 15Mbps 40M-BW)

1.3. Tested System Details

The types for all equipment, plus descriptions of all cables used in the tested system (including inserted cards) are:

Product	Manufacturer	Model No.	Serial No.	Power Cord
1 Notebook PC	DELL	Latitude 5580	2HRD7H2	Non-Shielded, 0.8m
2 LED Monitor	ViewSonic	VX2257-mhd	UFY163502150	Non-Shielded, 1.8m
3 DVD PLAYER	Pioneer	DV-600AV	GJKD006463LS	Non-Shielded, 1.8m
4 IR	N/A	N/A	N/A	N/A
5 Mouse	Logitech	M-SBM96B	810-000439	N/A
6 Remote Control	N/A	N/A	N/A	N/A

Signal Cable Type	Signal cable Description
A LAN Cable	Non-Shielded, 0.7m
B HDMI Cable	Non-Shielded, 1.8m
C Signal Cable	Non-Shielded, 1.8m
D IR Cable	Non-Shielded, 1.8m
E Mouse Cable	Shielded, 1.8m
E Fiber Cable	Non-Shielded, 1.5m
F RCA Cable	Non-Shielded, 1.5m

1.4. Configuration of Tested System

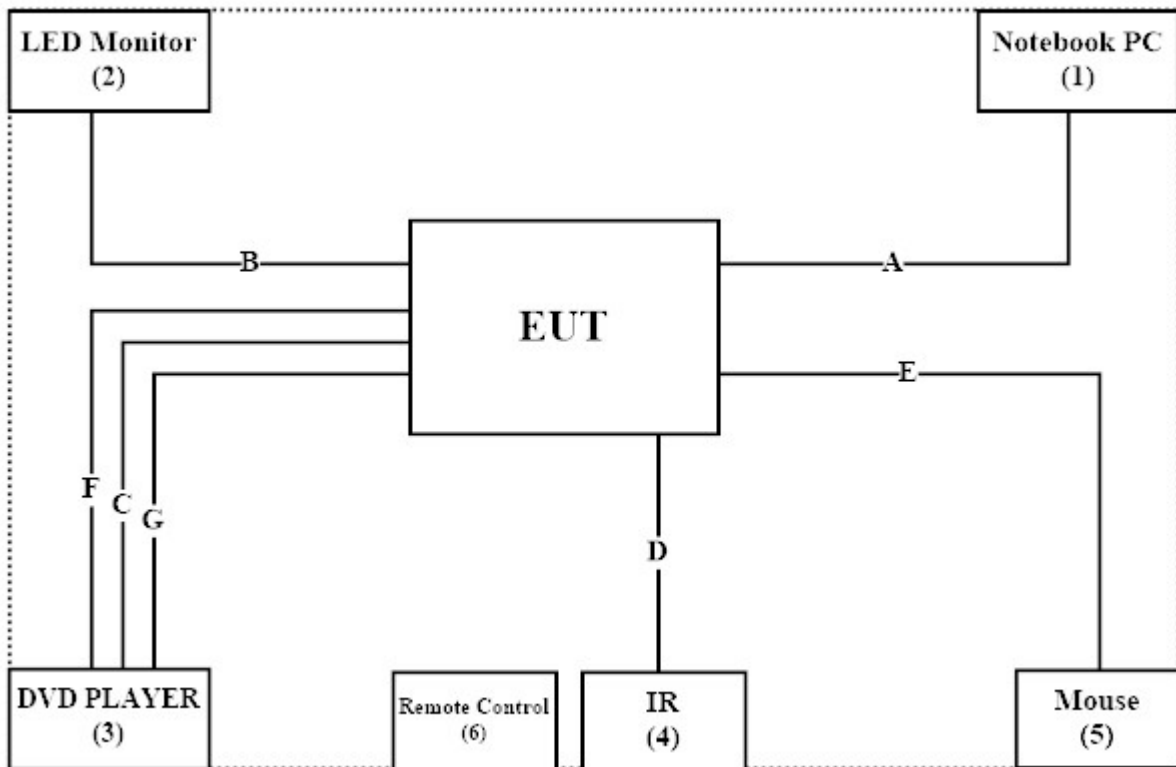

1.5. EUT Exercise Software

1. Setup the EUT as shown in Section 1.4.
2. Execute software “LINUX ” on the EUT.
3. Configure the test mode, the test channel, and the data rate.
4. Press “OK” to start the continuous Transmit.
5. Verify that the EUT works properly.

1.6. Test Facility

Ambient conditions in the laboratory:

Items	Required (IEC 68-1)	Actual
Temperature (°C)	15-35	20-35
Humidity (%RH)	25-75	50-65
Barometric pressure (mbar)	860-1060	950-1000

The related certificate for our laboratories about the test site and management system can be downloaded from DEKRA Testing and Certification Co., Ltd. Web Site:

<http://www.dekra.com.tw/english/about/certificates.aspx?bval=5>

The address and introduction of DEKRA Testing and Certification Co., Ltd. laboratories can be founded in our Web site: http://www.dekra.com.tw/index_en.aspx

Site Description: Accredited by TAF
Accredited Number: 3023

Site Name: DEKRA Testing and Certification Co., Ltd
Site Address: No.5-22, Ruishukeng, Linkou Dist., New Taipei City 24451,
Taiwan, R.O.C.
TEL : 886-2-8601-3788 / FAX : 886-2-8601-3789
E-Mail : info.tw@dekra.com

FCC Accreditation Number: TW3023

1.7. List of Test Equipment

For Conducted measurements /CB3/SR8

	Equipment	Manufacturer	Model No.	Serial No.	Cali. Date	Due. Date
	Temperature Chamber	WIT GROUP	TH-1S-B	EQ-201-00146	2018/02/12	2019/02/11
X	Spectrum Analyzer	Agilent	N9010A	MY53470892	2018/09/27	2019/09/26
X	Peak Power Analyzer	Keysight	8990B	MY51000410	2018/08/01	2019/07/31
X	Wideband Power Sensor	Keysight	N1923A	MY56080003	2018/07/25	2019/07/24
X	Wideband Power Sensor	Keysight	N1923A	MY56080004	2018/07/25	2019/07/24
X	EMI Test Receiver	R&S	ESCS 30	100369	2018/11/19	2019/11/18
X	LISN	R&S	ESH3-Z5	836679/017	2018/02/09	2019/02/08
X	LISN	R&S	ENV216	100097	2018/02/09	2019/02/08
X	Coaxial Cable	DEKRA	RG 400	LC018-RG	2018/06/21	2019/06/20

For Radiated measurements /Site3/CB8

	Equipment	Manufacturer	Model No.	Serial No.	Cali. Date	Due. Date
X	Spectrum Analyzer	R&S	FSP40	100170	2018/03/12	2019/03/11
X	Loop Antenna	Teseq	HLA6121	37133	2018/10/13	2019/10/12
X	Bilog Antenna	Schaffner Chase	CBL6112B	2707	2018/06/24	2019/06/23
X	Coaxial Cable	DEKRA	RG 214	LC003-RG	2018/06/14	2019/06/13
X	Pre-Amplifier	Jet-Power	JPA-10M1G33	170101000330010	2018/06/14	2019/06/13
X	Horn Antenna	ETS-Lindgren	3117	00135205	2018/05/03	2019/05/02
X	Horn Antenna	SCHWARZBECK	9120D	576	2018/11/30	2019/11/29
X	Pre-Amplifier	EMCI	EMC012630SE	980210	2018/04/10	2019/04/09
X	Horn Antenna	Com-Power	AH-840	101043	2018/01/09	2019/01/08
X	Amplifier + Cable	EMCI	EMC184045SE	980370	2018/03/21	2019/03/20
X	Filter	MICRO-TRONICS	BRM50702	G270	2018/08/06	2019/08/05
X	Filter	MICRO-TRONICS	BRM50716	G196	2018/08/06	2019/08/05

Note:

1. All equipments are calibrated every one year.
2. The test instruments marked with "X" are used to measure the final test results.
3. Test Software version :QuieTek EMI 2.0 V2.1.113.

2. Conducted Emission

2.1. Test Setup

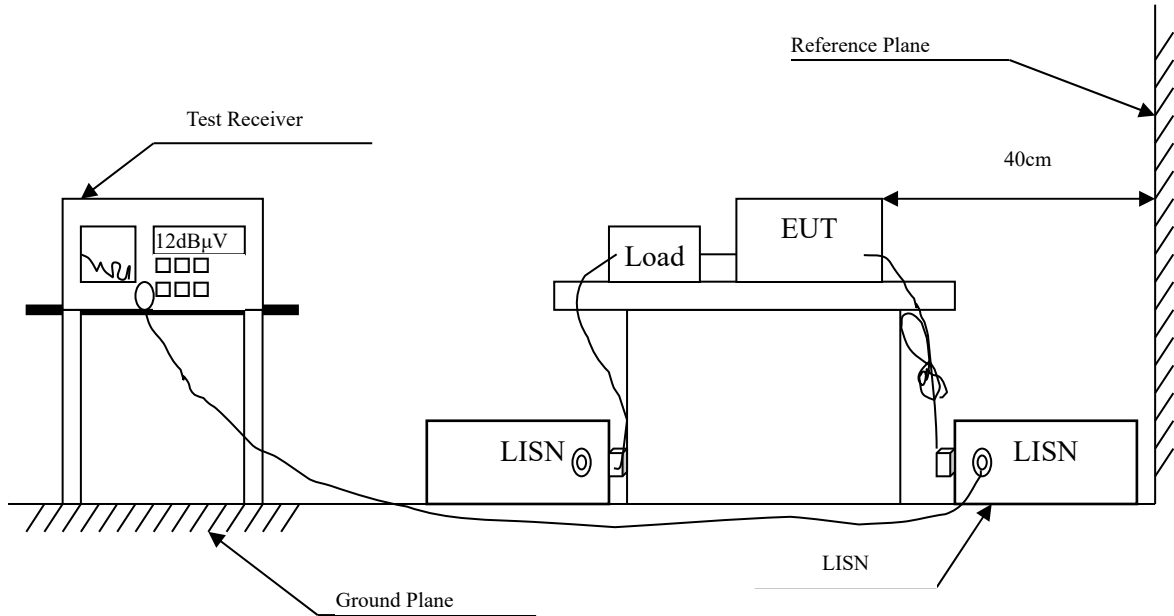

2.2. Limits

FCC Part 15 Subpart C Paragraph 15.207 (dB μ V) Limit		
Frequency MHz	Limits	
	QP	AVG
0.15 - 0.50	66-56	56-46
0.50-5.0	56	46
5.0 - 30	60	50

2.3. Test Procedure

The EUT and simulators are connected to the main power through a line impedance stabilization network (L.I.S.N.). This provides a 50 ohm /50uH coupling impedance for the measuring equipment. The peripheral devices are also connected to the main power through a LISN that provides a 50ohm /50uH coupling impedance with 50ohm termination. (Please refers to the block diagram of the test setup and photographs.)

Both sides of A.C. line are checked for maximum conducted interference. In order to find the maximum emission, the relative positions of equipment and all of the interface cables must be changed according to ANSI C63.4: 2014 on conducted measurement.

Conducted emissions were investigated over the frequency range from 0.15MHz to 30MHz using a receiver bandwidth of 9kHz.

2.4. Uncertainty

± 2.26 dB

2.5. Test Result of Conducted Emission

Product : STREAMING SOUNDBAR
 Test Item : Conducted Emission Test
 Power Line : Line 1
 Test Date : 2018/11/15
 Test Mode : Mode 4: Transmit (802.11n MCS0 15Mbps 40M-BW) (2437MHz) (DYS602-240250-15714A)

Frequency MHz	Correct Factor dB	Reading Level dB μ V	Measurement Level dB μ V	Margin dB	Limit dB μ V
Line 1					
Quasi-Peak					
0.189	9.737	28.900	38.637	-26.249	64.886
0.209	9.738	25.400	35.138	-29.176	64.314
0.349	9.744	31.300	41.044	-19.270	60.314
1.399	9.797	20.000	29.797	-26.203	56.000
8.498	10.033	27.720	37.753	-22.247	60.000
14.619	10.156	18.380	28.536	-31.464	60.000
Average					
0.189	9.737	15.450	25.187	-29.699	54.886
0.209	9.738	12.290	22.028	-32.286	54.314
0.349	9.744	24.000	33.744	-16.570	50.314
1.399	9.797	12.460	22.257	-23.743	46.000
8.498	10.033	26.170	36.203	-13.797	50.000
14.619	10.156	9.670	19.826	-30.174	50.000

Note:

1. All Reading Levels are Quasi-Peak and average value.
2. "■" means the worst emission level.
3. Measurement Level = Reading Level + Correct Factor

Product : STREAMING SOUNDBAR
 Test Item : Conducted Emission Test
 Power Line : Line 2
 Test Date : 2018/11/15
 Test Mode : Mode 4: Transmit (802.11n MCS0 15Mbps 40M-BW) (2437MHz) (DYS602-240250-15714A)

Frequency MHz	Correct Factor dB	Reading Level dB μ V	Measurement Level dB μ V	Margin dB	Limit dB μ V
Line 2					
Quasi-Peak					
0.162	9.736	33.720	43.456	-22.201	65.657
0.352	9.734	32.000	41.734	-18.495	60.229
2.112	9.826	19.980	29.806	-26.194	56.000
8.502	10.043	27.260	37.303	-22.697	60.000
13.818	10.201	19.850	30.051	-29.949	60.000
22.580	10.418	19.170	29.588	-30.412	60.000
Average					
0.162	9.736	19.680	29.416	-26.241	55.657
0.352	9.734	24.390	34.124	-16.105	50.229
2.112	9.826	12.920	22.746	-23.254	46.000
8.502	10.043	23.540	33.583	-16.417	50.000
13.818	10.201	10.800	21.001	-28.999	50.000
22.580	10.418	18.730	29.148	-20.852	50.000

Note:

1. All Reading Levels are Quasi-Peak and average value.
2. “” means the worst emission level.
3. Measurement Level = Reading Level + Correct Factor

LINE 1

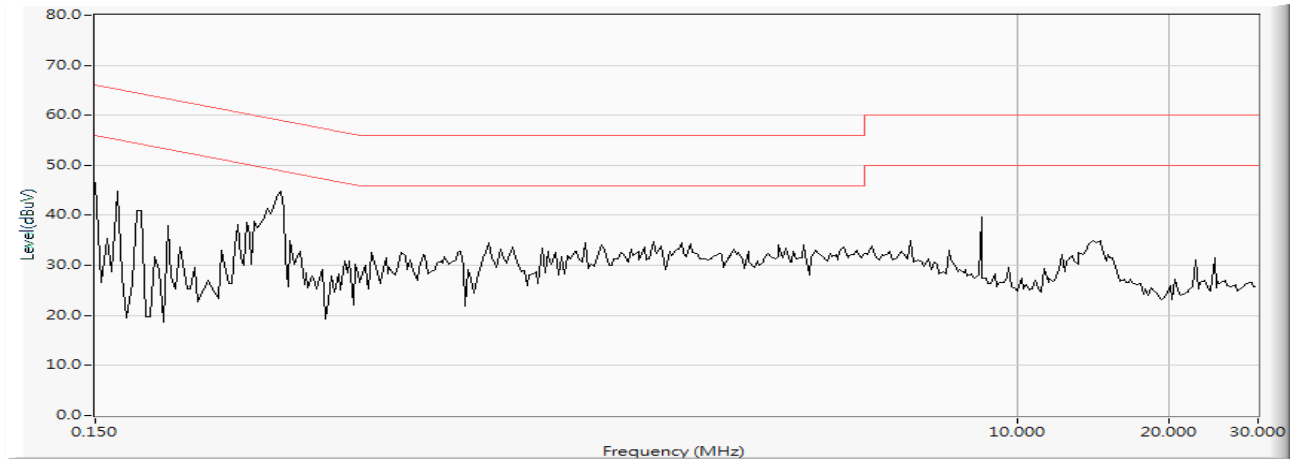

LINE 2

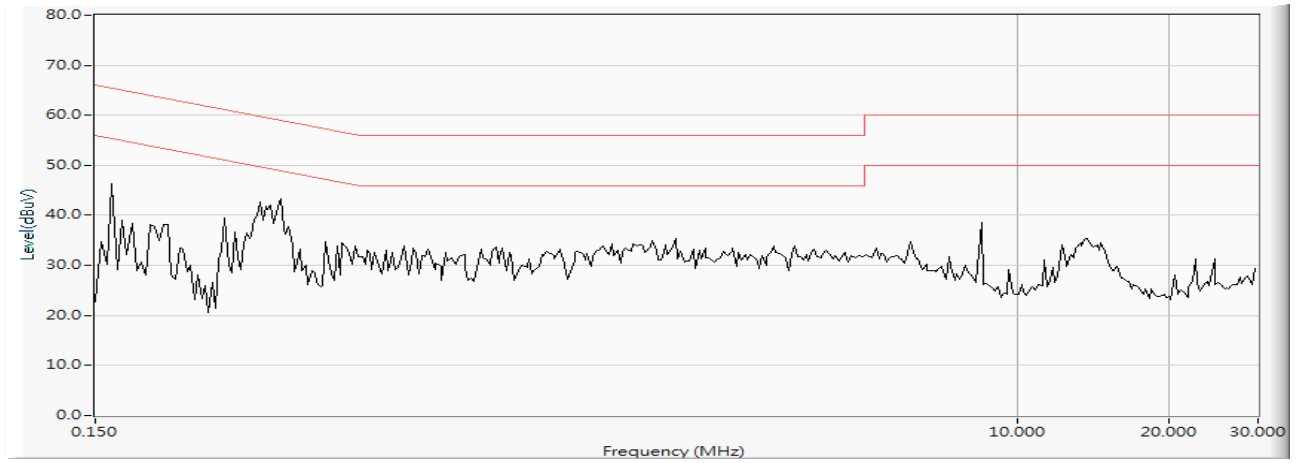

Product : STREAMING SOUNDBAR
 Test Item : Conducted Emission Test
 Power Line : Line 1
 Test Date : 2018/12/19
 Test Mode : Mode 4: Transmit (802.11n MCS0 15Mbps 40M-BW) (2437MHz) (F150602-A)

Frequency MHz	Correct Factor dB	Reading Level dB μ V	Measurement Level dB μ V	Margin dB	Limit dB μ V
Line 1					
Quasi-Peak					
0.166	9.744	36.020	45.764	-19.779	65.543
0.205	9.738	29.780	39.518	-24.911	64.429
0.220	9.739	26.220	35.959	-28.041	64.000
0.259	9.740	21.620	31.360	-31.526	62.886
0.423	9.747	17.360	27.107	-31.093	58.200
0.459	9.748	9.280	19.028	-38.143	57.171
Average					
0.166	9.744	17.680	27.424	-28.119	55.543
0.205	9.738	9.910	19.648	-34.781	54.429
0.220	9.739	6.220	15.959	-38.041	54.000
0.259	9.740	3.370	13.110	-39.776	52.886
0.423	9.747	7.130	16.877	-31.323	48.200
0.459	9.748	0.200	9.948	-37.223	47.171

Note:

4. All Reading Levels are Quasi-Peak and average value.
5. “” means the worst emission level.
6. Measurement Level = Reading Level + Correct Factor

Product : STREAMING SOUNDBAR
 Test Item : Conducted Emission Test
 Power Line : Line 2
 Test Date : 2018/12/19
 Test Mode : Mode 4: Transmit (802.11n MCS0 15Mbps 40M-BW) (2437MHz) (F150602-A)

Frequency MHz	Correct Factor dB	Reading Level dB μ V	Measurement Level dB μ V	Margin dB	Limit dB μ V
Line 2					
Quasi-Peak					
0.154	9.738	37.620	47.358	-18.528	65.886
0.170	9.737	34.180	43.917	-21.512	65.429
0.216	9.738	28.960	38.698	-25.416	64.114
0.236	9.739	24.940	34.679	-28.864	63.543
0.271	9.741	22.540	32.281	-30.262	62.543
0.431	9.737	15.760	25.497	-32.474	57.971
Average					
0.154	9.738	16.750	26.488	-29.398	55.886
0.170	9.737	14.250	23.987	-31.442	55.429
0.216	9.738	9.740	19.478	-34.636	54.114
0.236	9.739	6.130	15.869	-37.674	53.543
0.271	9.741	5.060	14.801	-37.742	52.543
0.431	9.737	4.230	13.967	-34.004	47.971

Note:

4. All Reading Levels are Quasi-Peak and average value.
5. “█” means the worst emission level.
6. Measurement Level = Reading Level + Correct Factor

LINE 1

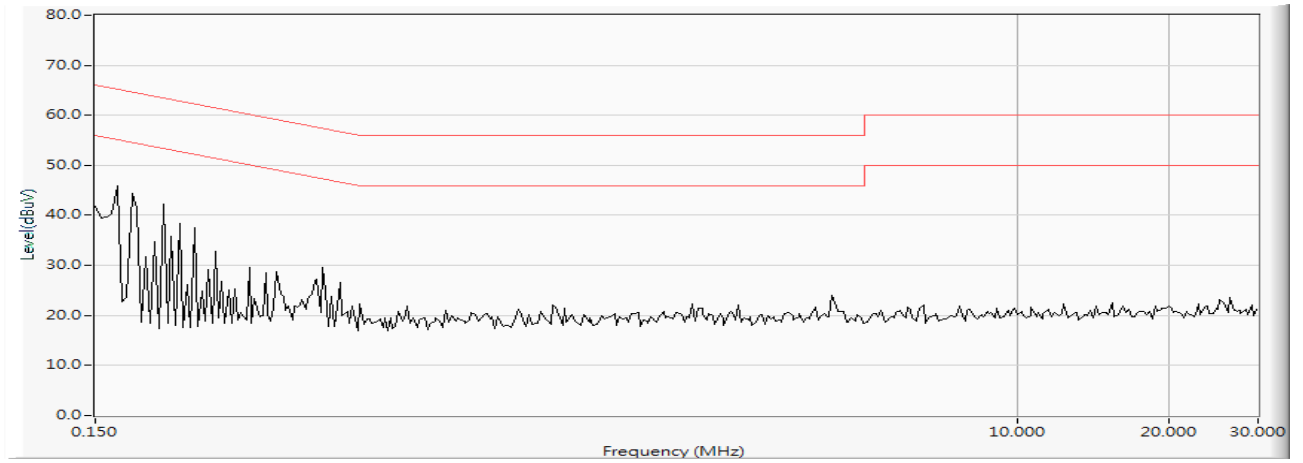

LINE 2

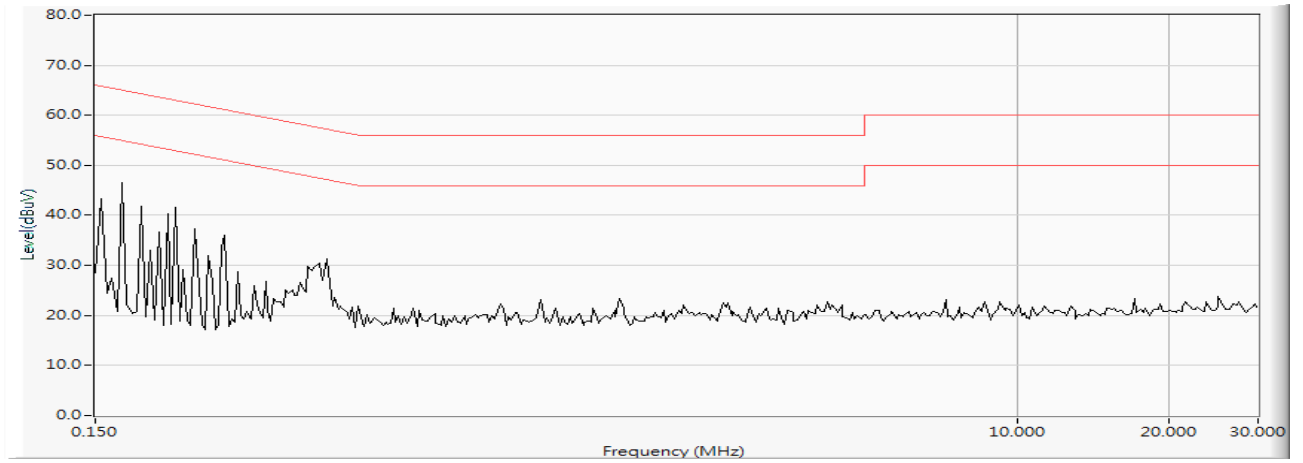

3. Peak Power Output

3.1. Test Setup

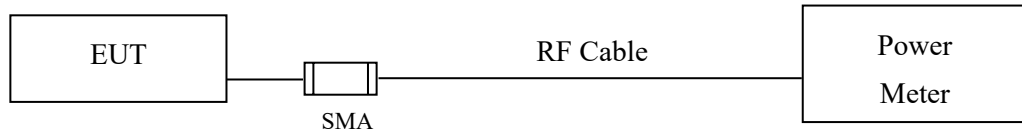

3.2. Limits

The maximum peak power shall be less 1 Watt.

3.3. Test Procedure

Tested according to DTS test procedure of KDB 558074 for compliance to FCC 47CFR 15.247 requirements. The maximum peak conducted output power using KDB 558074 section 9.1.3 PKPM1 Peak power meter method.

3.4. Uncertainty

± 1.19 dB

3.5. Test Result of Peak Power Output

Product : STREAMING SOUNDBAR
 Test Item : Peak Power Output Data
 Test Site : No.3 OATS
 Test Date : 2018/10/30
 Test Mode : Mode 1: Transmit (802.11b 1Mbps)

Channel No	Frequency (MHz)	Average Power For different Data Rate (Mbps)				Peak Power	Required Limit	Result
		1	2	5.5	11	1		
		Measurement Level (dBm)						
01	2412	13.67	--	--	--	16.71	<30dBm	Pass
06	2437	14.57	14.51	14.42	14.35	17.61	<30dBm	Pass
11	2462	15.2	--	--	--	18.39	<30dBm	Pass

Note: Peak Power Output Value = Reading value on power meter + cable loss

Product : STREAMING SOUNDBAR
 Test Item : Peak Power Output Data
 Test Site : No.3 OATS
 Test Date : 2018/10/30
 Test Mode : Mode 2: Transmit (802.11g 6Mbps)

Channel No	Frequency (MHz)	Average Power For different Data Rate (Mbps)								Peak Power	Required Limit	Result
		6	9	12	18	24	36	48	54			
		Measurement Level (dBm)										
01	2412	13.5	--	--	--	--	--	--	--	19.99	<30dBm	Pass
06	2437	14.02	13.95	13.89	13.81	13.75	13.68	13.6	13.52	20.68	<30dBm	Pass
11	2462	14.32	--	--	--	--	--	--	--	21.33	<30dBm	Pass

Note: Peak Power Output Value = Reading value on power meter + cable loss

Product : STREAMING SOUNDBAR
 Test Item : Peak Power Output Data
 Test Site : No.3 OATS
 Test Date : 2018/10/30
 Test Mode : Mode 3: Transmit (802.11n MCS0 7.2Mbps 20M-BW)

Channel No	Frequency (MHz)	Average Power For different Data Rate (Mbps)								Peak Power	Required Limit	Result
		7.2	14.4	21.7	28.9	43.3	57.8	65	72.2			
		Measurement Level (dBm)										
01	2412	11.49	--	--	--	--	--	--	--	19.41	<30dBm	Pass
06	2437	12.27	12.21	12.13	12.06	11.98	11.91	11.85	11.77	20.02	<30dBm	Pass
11	2462	12.5	--	--	--	--	--	--	--	20.51	<30dBm	Pass

Note: Peak Power Output Value = Reading value on power meter + cable loss

Product : STREAMING SOUNDBAR
 Test Item : Peak Power Output Data
 Test Site : No.3 OATS
 Test Date : 2018/10/30
 Test Mode : Mode 4: Transmit (802.11n MCS0 15Mbps 40M-BW)

Channel No	Frequency (MHz)	Average Power For different Data Rate (Mbps)								Peak Power	Required Limit	Result
		15	30	45	60	90	120	135	150			
		Measurement Level (dBm)										
03	2422	10.68	--	--	--	--	--	--	--	18.73	<30dBm	Pass
06	2437	10.91	10.85	10.77	10.71	10.62	10.58	10.5	10.44	18.68	<30dBm	Pass
09	2452	11.41	--	--	--	--	--	--	--	19.45	<30dBm	Pass

Note: Peak Power Output Value = Reading value on power meter + cable loss

4. Radiated Emission

4.1. Test Setup

Radiated Emission Under 30MHz

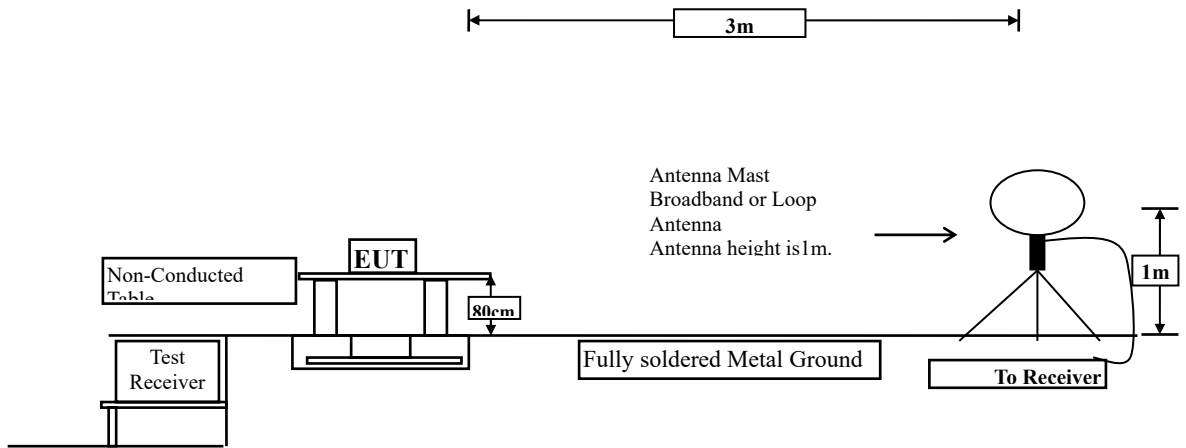

Radiated Emission Below 1GHz

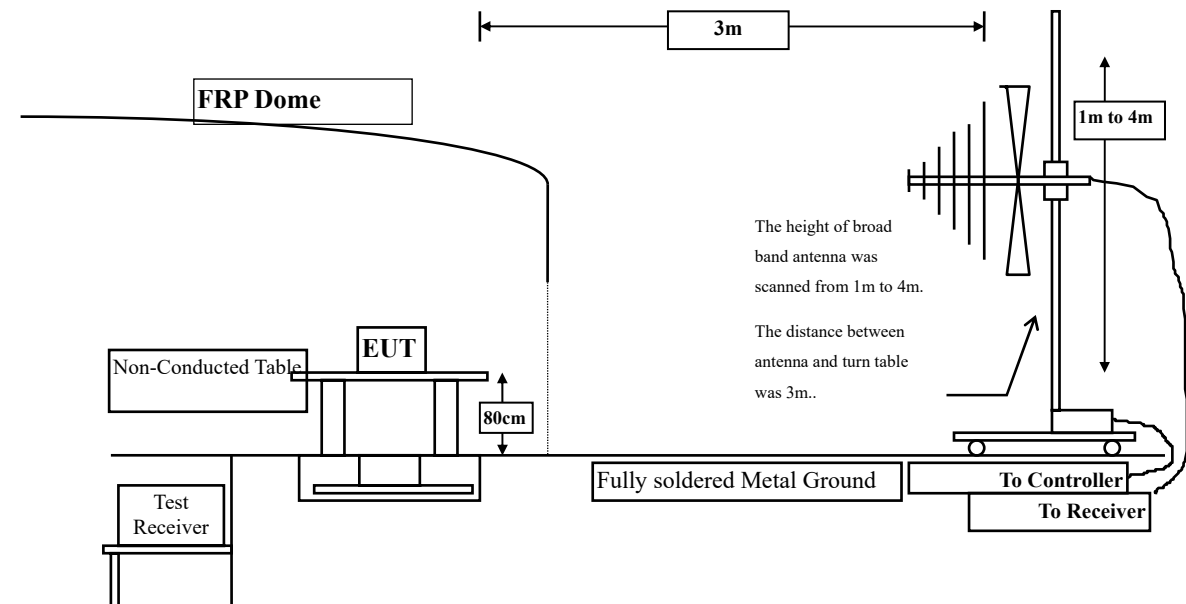

Radiated Emission Above 1GHz

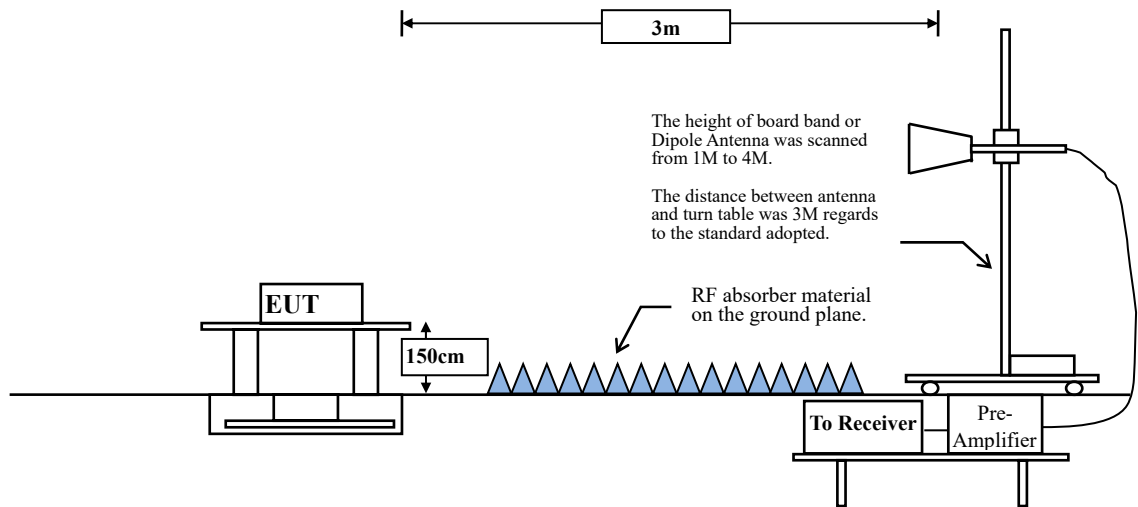

4.2. Limits

Emissions radiated outside of the specified frequency bands, except for harmonics, shall be attenuated by at least 20dB below the level of the fundamental or to the general radiated emission limits in paragraph 15.209, whichever is the lesser attenuation.

FCC Part 15 Subpart C Paragraph 15.209(a) Limits		
Frequency MHz	Field strength (microvolts/meter)	Measurement distance (meter)
0.009-0.490	2400/F(kHz)	300
0.490-1.705	24000/F(kHz)	30
1.705-30	30	30
30-88	100	3
88-216	150	3
216-960	200	3
Above 960	500	3

Remarks: E field strength (dBμV/m) = 20 log E field strength (uV/m)

4.3. Test Procedure

The EUT was setup according to ANSI C63.10: 2013 and tested according to DTS test procedure of KDB558074 for compliance to FCC 47CFR 15.247 requirements.

Measuring the frequency range below 1GHz, the EUT is placed on a turn table which is 0.8 meter above ground, when measuring the frequency range above 1GHz, the EUT is placed on a turn table which is 1.5 meter above ground.

The turn table is rotated 360 degrees to determine the position of the maximum emission level.

The EUT was positioned such that the distance from antenna to the EUT was 3 meters.

The antenna is scanned between 1 meter and 4 meters to find out the maximum emission level. This is repeated for both horizontal and vertical polarization of the antenna. In order to find the maximum emission, all of the interface cables were manipulated according to ANSI C63.10: 2013 on radiated measurement.

The resolution bandwidth below 30MHz setting on the field strength meter is 9kHz and 30MHz~1GHz is 120kHz and above 1GHz is 1MHz.

Radiated emission measurements below 30MHz are made using Loop Antenna and 30MHz~1GHz are made using broadband Bilog antenna and above 1GHz are made using Horn Antennas.

The measurement is divided into the Preliminary Measurement and the Final Measurement.

The suspected frequencies are searched for in Preliminary Measurement with the measurement antenna kept pointed at the source of the emission both in azimuth and elevation, with the polarization of the antenna oriented for maximum response. The antenna is pointed at an angle towards the source of the emission, and the EUT is rotated in both height and polarization to maximize the measured emission. The emission is kept within the illumination area of the 3 dB bandwidth of the antenna.

The worst radiated emission is measured in the Open Area Test Site on the Final Measurement.

The measurement frequency range from 9kHz - 10th Harmonic of fundamental was investigated.

RBW and VBW Parameter setting:

According to KDB 558074 section 12.2.4. Peak power measurement procedure

RBW = as specified in Table 1.

$VBW \geq 3 \times RBW$.

Table 1 —RBW as a function of frequency

Frequency	RBW
9-150 kHz	200-300 Hz
0.15-30 MHz	9-10 kHz
30-1000 MHz	100-120 kHz
> 1000 MHz	1 MHz

According to KDB 558074 section 12.2.5. Average power measurement procedure

RBW = 1MHz.

VBW = 10Hz, when duty cycle $\geq 98 \%$

$VBW \geq 1/T$, when duty cycle $< 98 \%$

(T refers to the minimum transmission duration over which the transmitter is on and is transmitting at its maximum power control level for the tested mode of operation.)

2.4GHz band	Duty Cycle (%)	T (ms)	1/T (Hz)	VBW (Hz)
802.11b	89.46	0.8400	1190	2kHz
802.11g	63.51	0.1768	5656	6kHz
802.11n20	61.60	0.1644	6083	7kHz
802.11n40	49.29	0.1000	10000	10kHz

Note: Duty Cycle Refer to Section 9

4.4. Uncertainty

± 4.08 dB above 1GHz

± 4.22 dB below 1GHz

4.5. Test Result of Radiated Emission

Product : STREAMING SOUNDBAR
Test Item : Harmonic Radiated Emission Data
Test Site : No.3 OATS
Test Date : 2018/11/01
Test Mode : Mode 1: Transmit (802.11b 1Mbps) (2412MHz)

Horizontal:

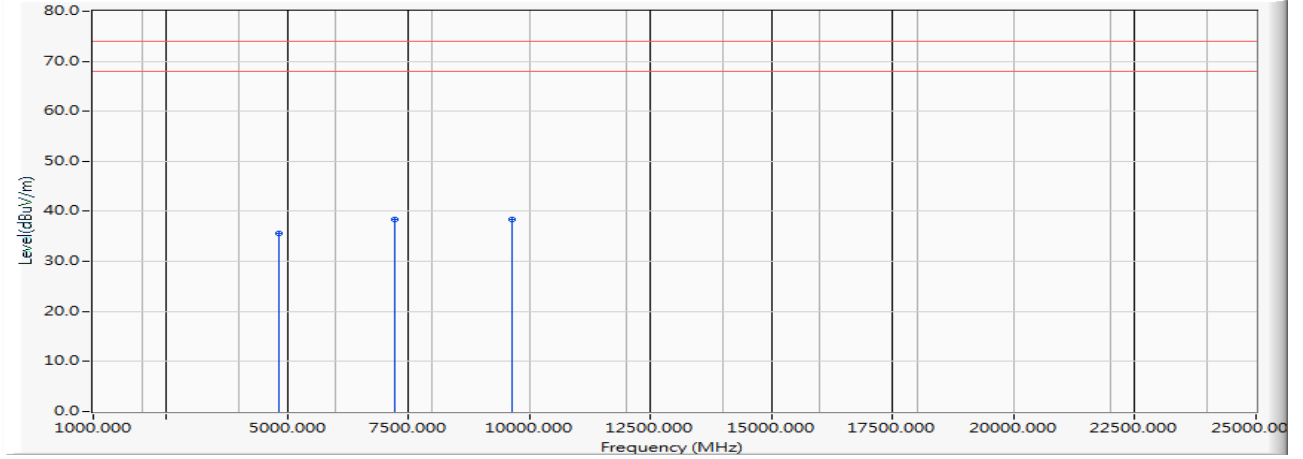

Vertical:

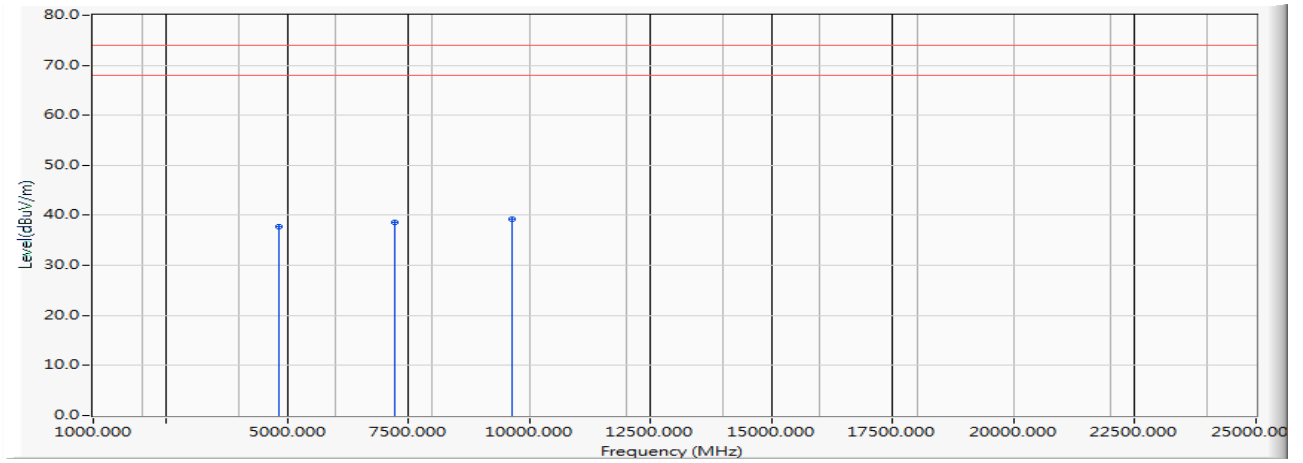

Frequency MHz	Correct Factor dB	Reading Level dB μ V	Measurement Level dB μ V/m	Margin dB	Limit dB μ V/m
Horizontal					
Peak Detector:					
4824.000	6.858	28.740	35.598	-38.402	74.000
7236.000	11.502	26.954	38.456	-35.544	74.000
9648.000	14.752	23.570	38.323	-35.677	74.000
Average Detector:					
--					
Vertical					
Peak Detector:					
4824.000	6.858	30.920	37.778	-36.222	74.000
7236.000	11.502	27.111	38.613	-35.387	74.000
9648.000	14.752	24.545	39.298	-34.702	74.000
Average Detector:					
--					

Note:

1. All Readings below 1GHz are Quasi-Peak, above 1GHz are performed with peak and/or average measurements as necessary.
2. Measurement Level = Reading Level + Correct Factor.
3. Correct Factor = Antenna factor + Cable loss – Amplifier gain.
4. The average measurement was not performed when the peak measured data under the limit of average detection.
5. The emission levels of other frequencies are very lower than the limit and not show in test report.

Product : STREAMING SOUNDBAR
Test Item : Harmonic Radiated Emission Data
Test Site : No.3 OATS
Test Date : 2018/11/01
Test Mode : Mode 1: Transmit (802.11b 1Mbps) (2437 MHz)

Horizontal:

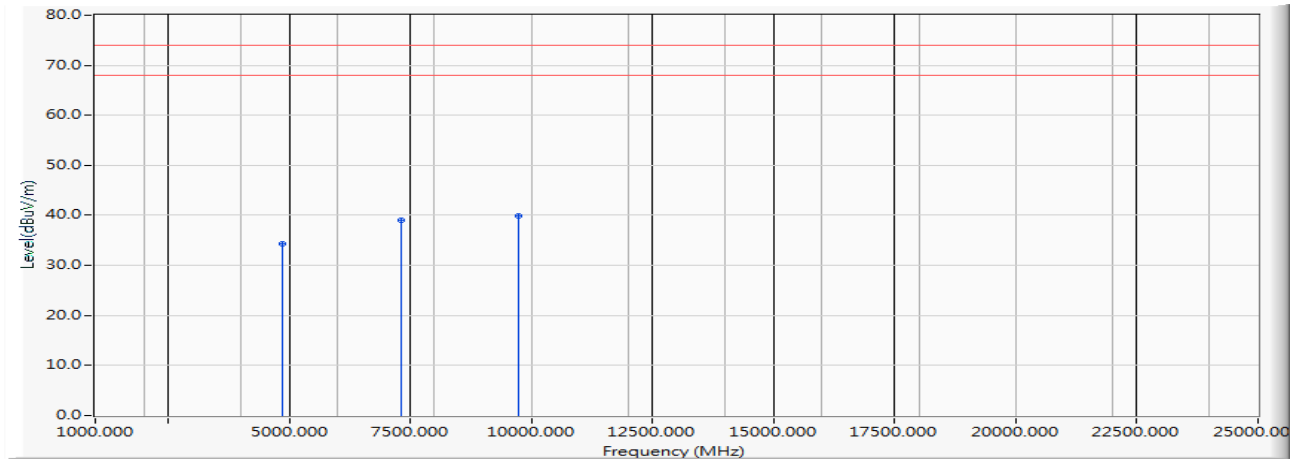

Vertical:

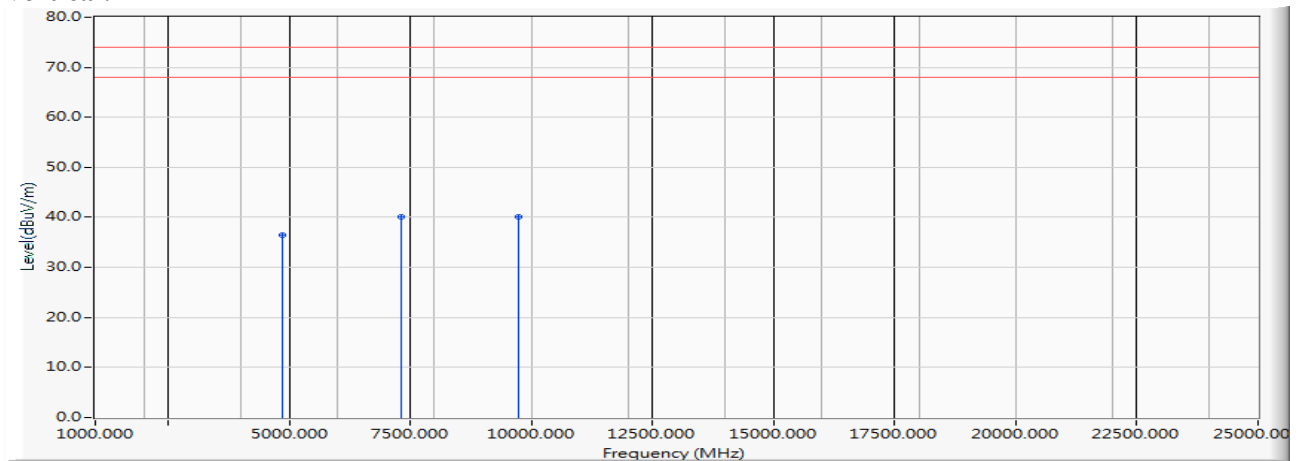

Frequency MHz	Correct Factor dB	Reading Level dB μ V	Measurement Level dB μ V/m	Margin dB	Limit dB μ V/m
Horizontal					
Peak Detector:					
4874.000	6.921	27.454	34.375	-39.625	74.000
7311.000	11.462	27.484	38.946	-35.054	74.000
9748.000	15.194	24.651	39.845	-34.155	74.000
Average Detector:					
--					
Vertical					
Peak Detector:					
4874.000	6.921	29.522	36.443	-37.557	74.000
7311.000	11.462	28.746	40.208	-33.792	74.000
9748.000	15.194	24.819	40.013	-33.987	74.000
Average Detector:					
--					

Note:

1. All Readings below 1GHz are Quasi-Peak, above 1GHz are performed with peak and/or average measurements as necessary.
2. Measurement Level = Reading Level + Correct Factor.
3. Correct Factor = Antenna factor + Cable loss – Amplifier gain.
4. The average measurement was not performed when the peak measured data under the limit of average detection.
5. The emission levels of other frequencies are very lower than the limit and not show in test report.

Product : STREAMING SOUNDBAR
Test Item : Harmonic Radiated Emission Data
Test Site : No.3 OATS
Test Date : 2018/11/01
Test Mode : Mode 1: Transmit (802.11b 1Mbps) (2462 MHz)

Horizontal:

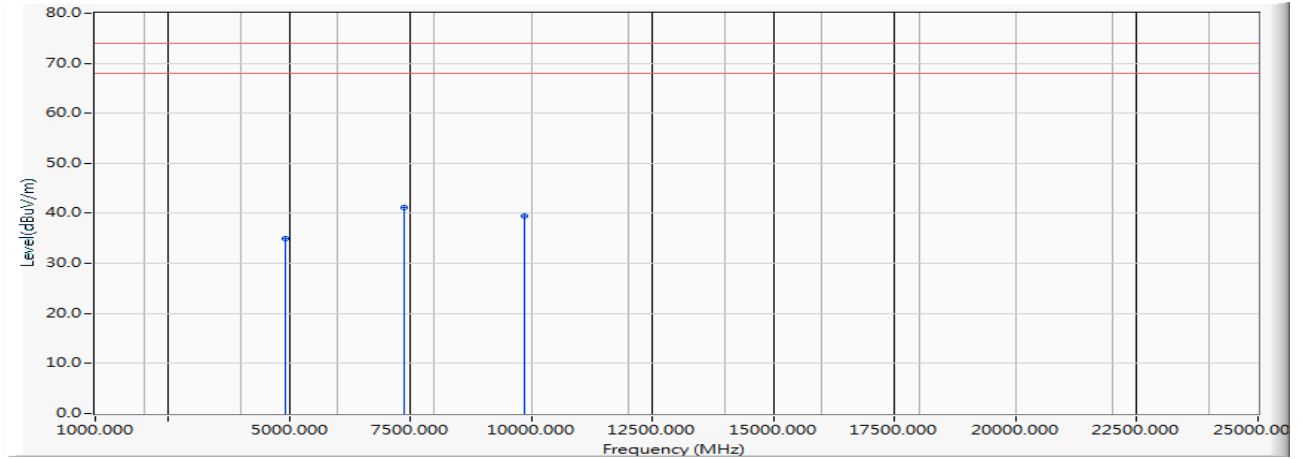

Vertical:

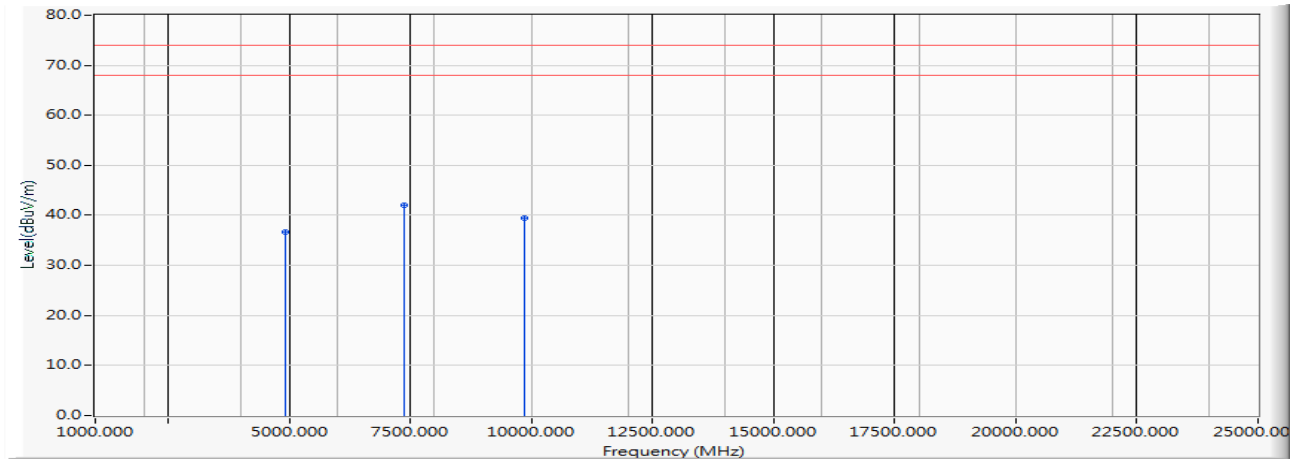

Frequency MHz	Correct Factor dB	Reading Level dB μ V	Measurement Level dB μ V/m	Margin dB	Limit dB μ V/m
Horizontal					
Peak Detector:					
4924.000	6.982	27.871	34.853	-39.147	74.000
7386.000	11.436	29.699	41.135	-32.865	74.000
9848.000	15.087	24.326	39.413	-34.587	74.000
Average Detector:					
--					
Vertical					
Peak Detector:					
4924.000	6.982	29.642	36.624	-37.376	74.000
7386.000	11.436	30.508	41.944	-32.056	74.000
9848.000	15.087	24.311	39.398	-34.602	74.000
Average Detector:					
--					

Note:

1. All Readings below 1GHz are Quasi-Peak, above 1GHz are performed with peak and/or average measurements as necessary.
2. Measurement Level = Reading Level + Correct Factor.
3. Correct Factor = Antenna factor + Cable loss – Amplifier gain.
4. The average measurement was not performed when the peak measured data under the limit of average detection.
5. The emission levels of other frequencies are very lower than the limit and not show in test report.

Product : STREAMING SOUNDBAR
Test Item : Harmonic Radiated Emission Data
Test Site : No.3 OATS
Test Date : 2018/11/01
Test Mode : Mode 2: Transmit (802.11g 6Mbps) (2412MHz)

Horizontal:

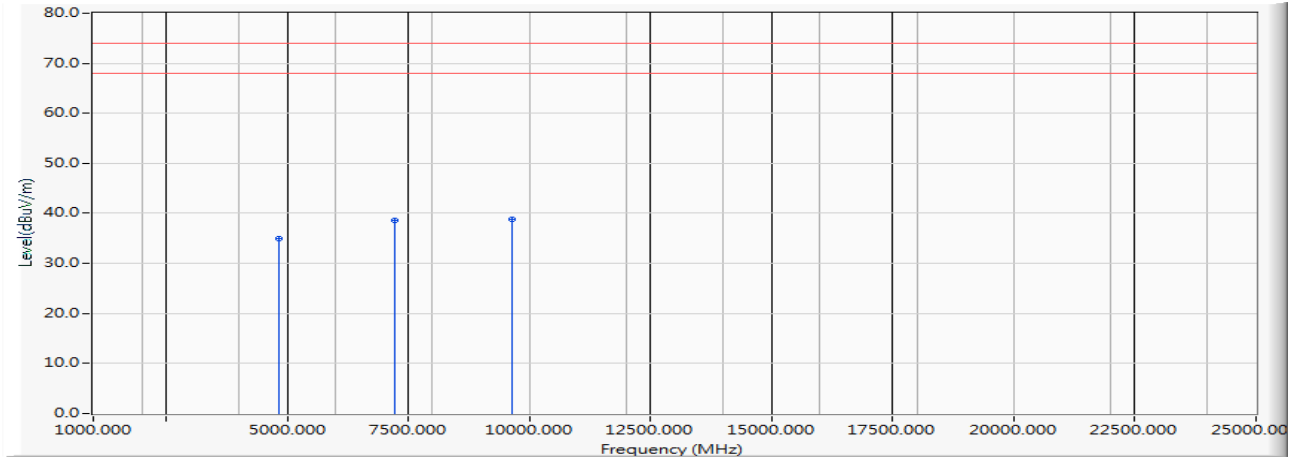

Vertical:

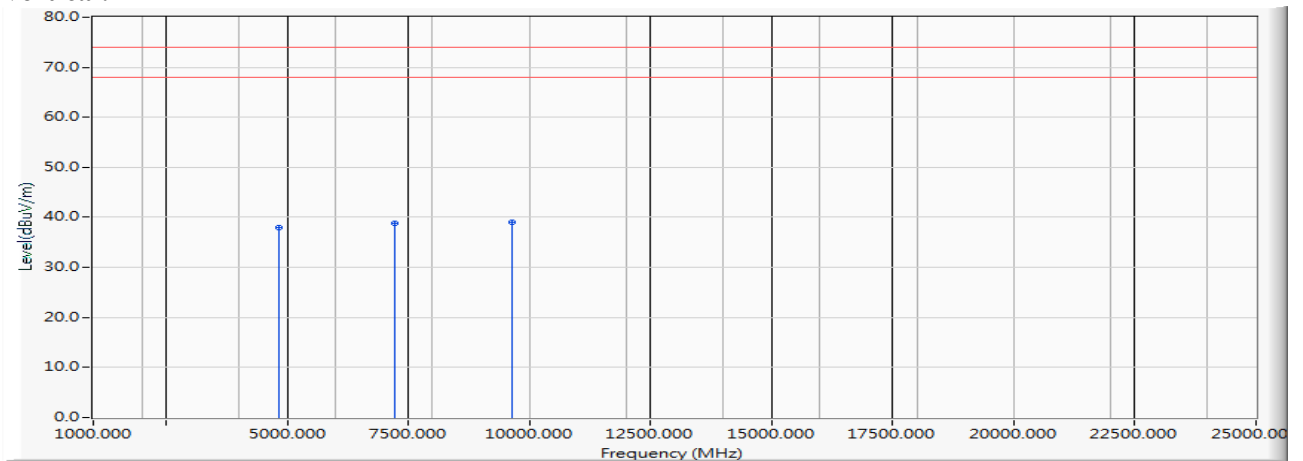

Frequency MHz	Correct Factor dB	Reading Level dB μ V	Measurement Level dB μ V/m	Margin dB	Limit dB μ V/m
Horizontal					
Peak Detector:					
4824.000	6.858	28.063	34.921	-39.079	74.000
7236.000	11.502	27.056	38.558	-35.442	74.000
9648.000	14.752	23.990	38.743	-35.257	74.000
Average Detector:					
--					
Vertical					
Peak Detector:					
4824.000	6.858	31.178	38.036	-35.964	74.000
7236.000	11.502	27.268	38.770	-35.230	74.000
9648.000	14.752	24.332	39.085	-34.915	74.000
Average Detector:					
--					

Note:

1. All Readings below 1GHz are Quasi-Peak, above 1GHz are performed with peak and/or average measurements as necessary.
2. Measurement Level = Reading Level + Correct Factor.
3. Correct Factor = Antenna factor + Cable loss – Amplifier gain.
4. The average measurement was not performed when the peak measured data under the limit of average detection.
5. The emission levels of other frequencies are very lower than the limit and not show in test report.

Product : STREAMING SOUNDBAR
Test Item : Harmonic Radiated Emission Data
Test Site : No.3 OATS
Test Date : 2018/11/01
Test Mode : Mode 2: Transmit (802.11g 6Mbps) (2437 MHz)

Horizontal:

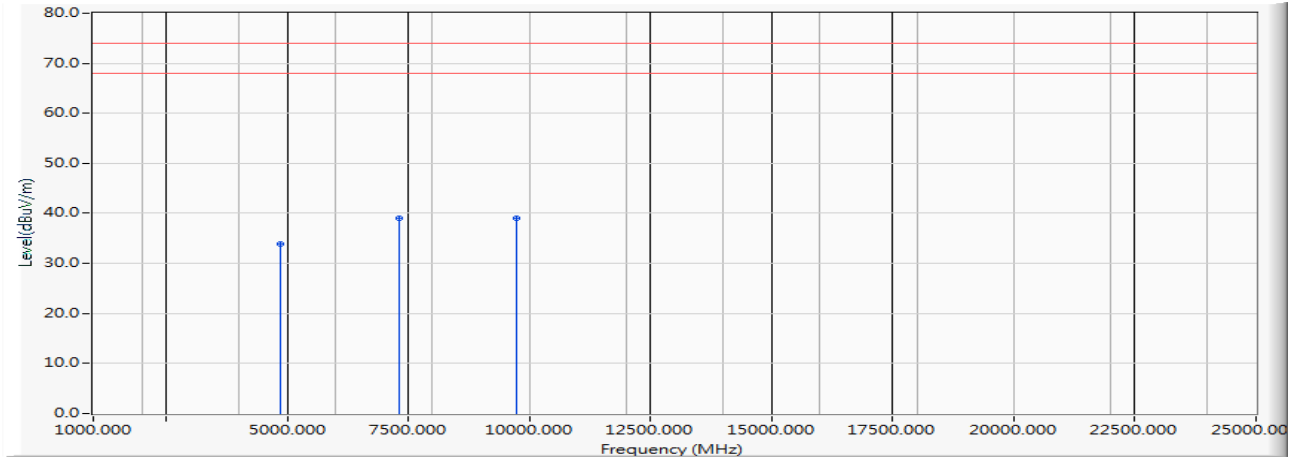

Vertical:

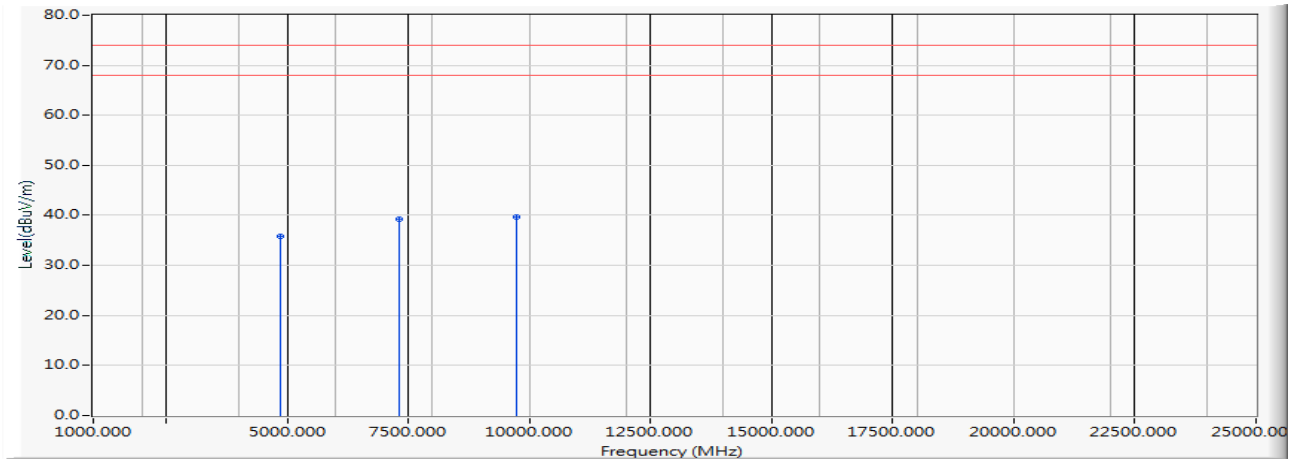

Frequency MHz	Correct Factor dB	Reading Level dB μ V	Measurement Level dB μ V/m	Margin dB	Limit dB μ V/m
Horizontal					
Peak Detector:					
4874.000	6.921	26.899	33.820	-40.180	74.000
7311.000	11.462	27.658	39.120	-34.880	74.000
9748.000	15.194	23.764	38.958	-35.042	74.000
Average Detector:					
--					
Vertical					
Peak Detector:					
4874.000	6.921	28.796	35.717	-38.283	74.000
7311.000	11.462	27.692	39.154	-34.846	74.000
9748.000	15.194	24.415	39.609	-34.391	74.000
Average Detector:					
--					

Note:

1. All Readings below 1GHz are Quasi-Peak, above 1GHz are performed with peak and/or average measurements as necessary.
2. Measurement Level = Reading Level + Correct Factor.
3. Correct Factor = Antenna factor + Cable loss – Amplifier gain.
4. The average measurement was not performed when the peak measured data under the limit of average detection.
5. The emission levels of other frequencies are very lower than the limit and not show in test report.

Product : STREAMING SOUNDBAR
Test Item : Harmonic Radiated Emission Data
Test Site : No.3 OATS
Test Date : 2018/11/01
Test Mode : Mode 2: Transmit (802.11g 6Mbps) (2462 MHz)

Horizontal:

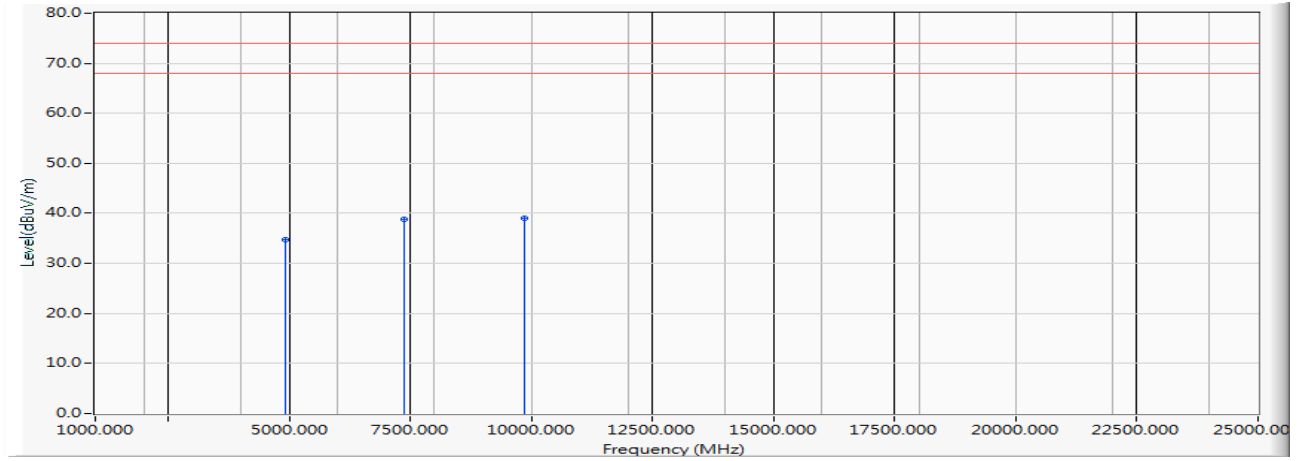

Vertical:

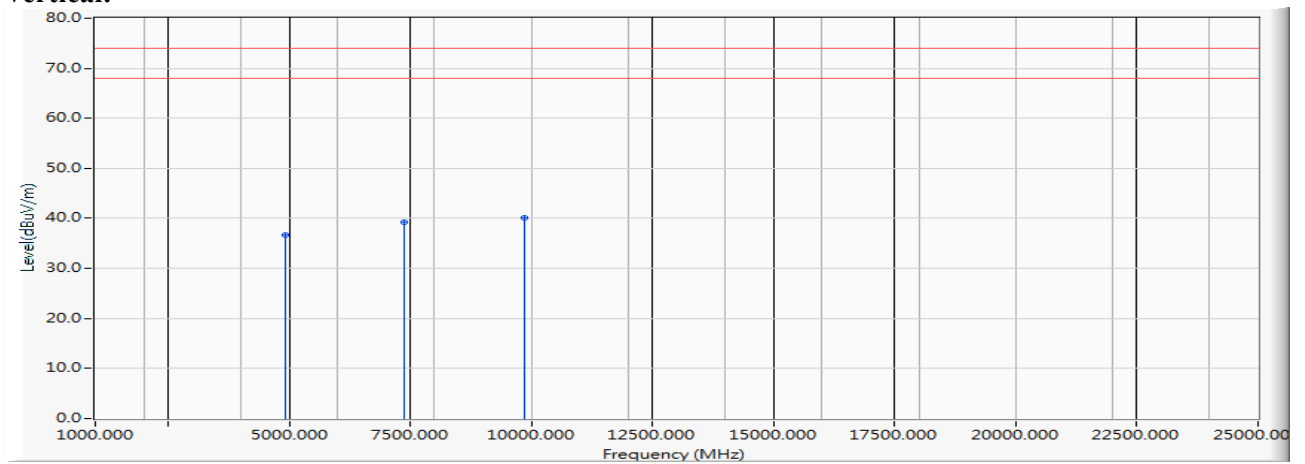

Frequency MHz	Correct Factor dB	Reading Level dB μ V	Measurement Level dB μ V/m	Margin dB	Limit dB μ V/m
Horizontal					
Peak Detector:					
4924.000	6.982	27.671	34.653	-39.347	74.000
7386.000	11.436	27.315	38.751	-35.249	74.000
9848.000	15.087	24.019	39.106	-34.894	74.000
Average Detector:					
--					
Vertical					
Peak Detector:					
4924.000	6.982	29.594	36.576	-37.424	74.000
7386.000	11.436	27.817	39.253	-34.747	74.000
9848.000	15.087	24.988	40.075	-33.925	74.000
Average Detector:					
--					

Note:

1. All Readings below 1GHz are Quasi-Peak, above 1GHz are performed with peak and/or average measurements as necessary.
2. Measurement Level = Reading Level + Correct Factor.
3. Correct Factor = Antenna factor + Cable loss – Amplifier gain.
4. The average measurement was not performed when the peak measured data under the limit of average detection.
5. The emission levels of other frequencies are very lower than the limit and not show in test report.

Product : STREAMING SOUNDBAR
Test Item : Harmonic Radiated Emission Data
Test Site : No.3 OATS
Test Date : 2018/11/01
Test Mode : Mode 3: Transmit (802.11n MCS0 7.2Mbps 20M-BW)(2412MHz)

Horizontal:

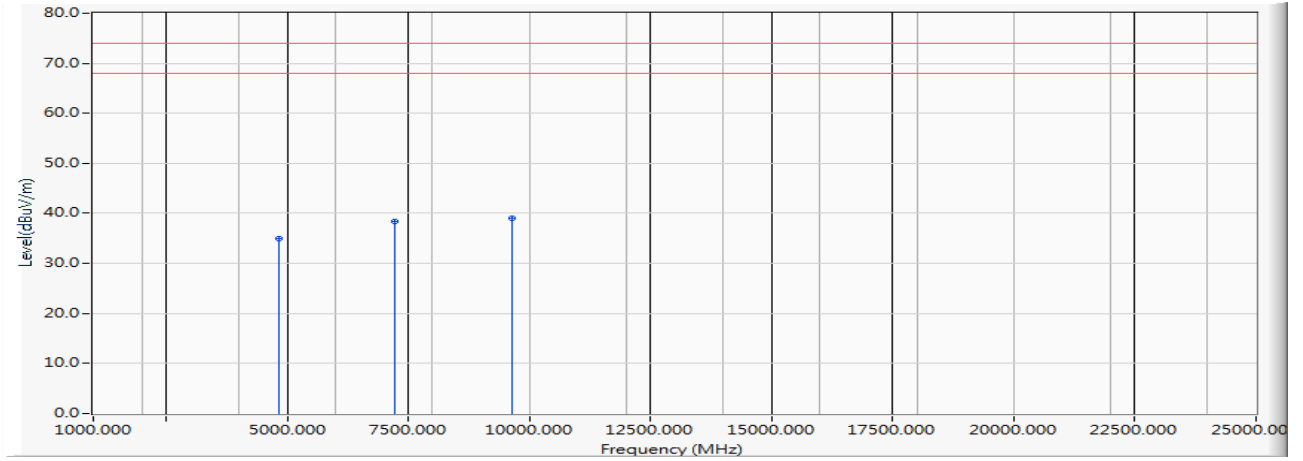

Vertical:

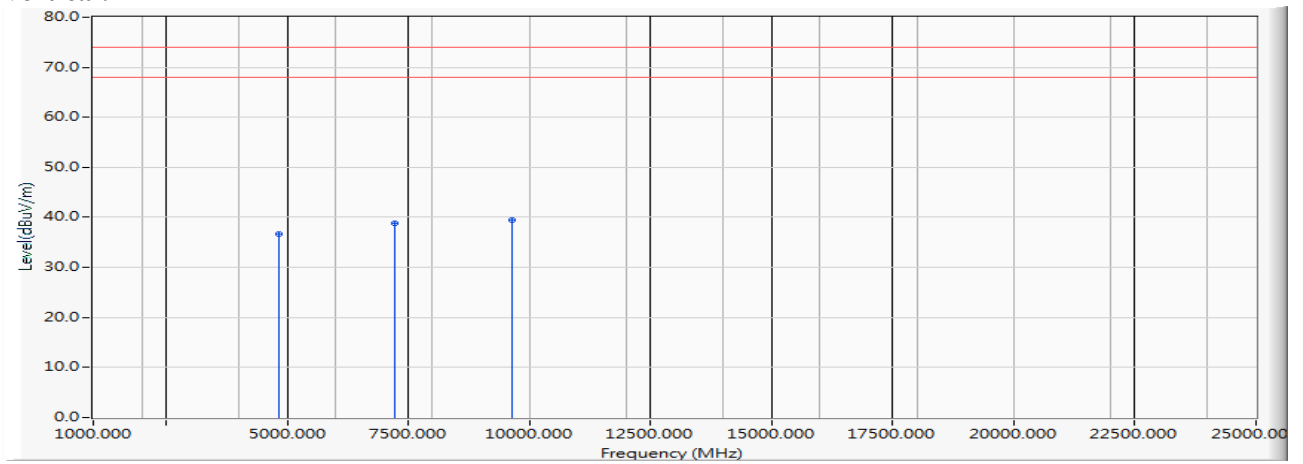

Frequency MHz	Correct Factor dB	Reading Level dB μ V	Measurement Level dB μ V/m	Margin dB	Limit dB μ V/m
Horizontal					
Peak Detector:					
4824.000	6.858	28.200	35.058	-38.942	74.000
7236.000	11.502	26.859	38.361	-35.639	74.000
9648.000	14.752	24.207	38.960	-35.040	74.000
Average Detector:					
--					
Vertical					
Peak Detector:					
4824.000	6.858	29.786	36.644	-37.356	74.000
7236.000	11.502	27.257	38.759	-35.241	74.000
9648.000	14.752	24.624	39.377	-34.623	74.000
Average Detector:					
--					

Note:

1. All Readings below 1GHz are Quasi-Peak, above 1GHz are performed with peak and/or average measurements as necessary.
2. Measurement Level = Reading Level + Correct Factor.
3. Correct Factor = Antenna factor + Cable loss – Amplifier gain.
4. The average measurement was not performed when the peak measured data under the limit of average detection.
5. The emission levels of other frequencies are very lower than the limit and not show in test report.

Product : STREAMING SOUNDBAR
Test Item : Harmonic Radiated Emission Data
Test Site : No.3 OATS
Test Date : 2018/11/01
Test Mode : Mode 3: Transmit (802.11n MCS0 7.2Mbps 20M-BW) (2437 MHz)

Horizontal:

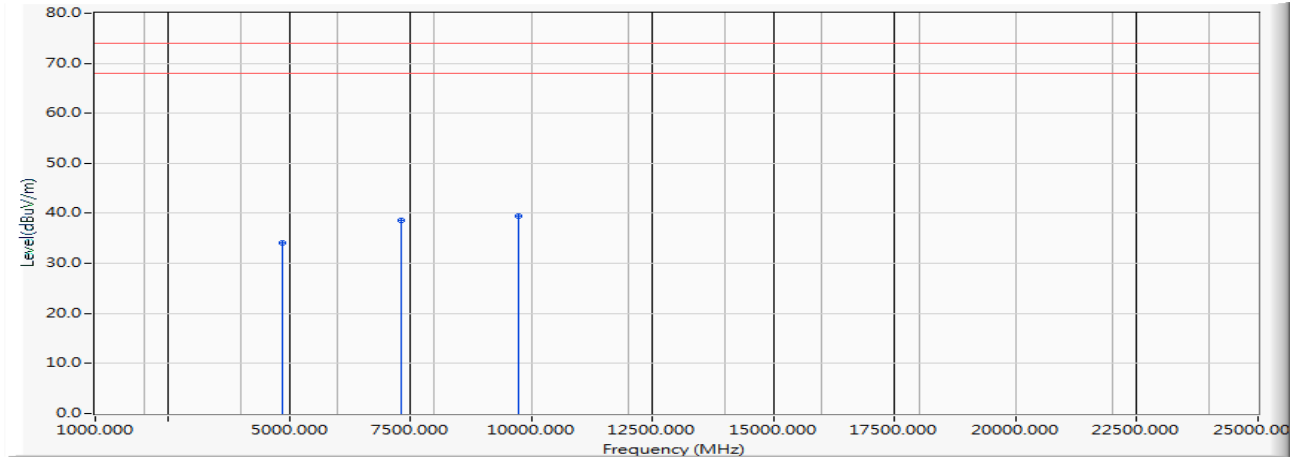

Vertical:

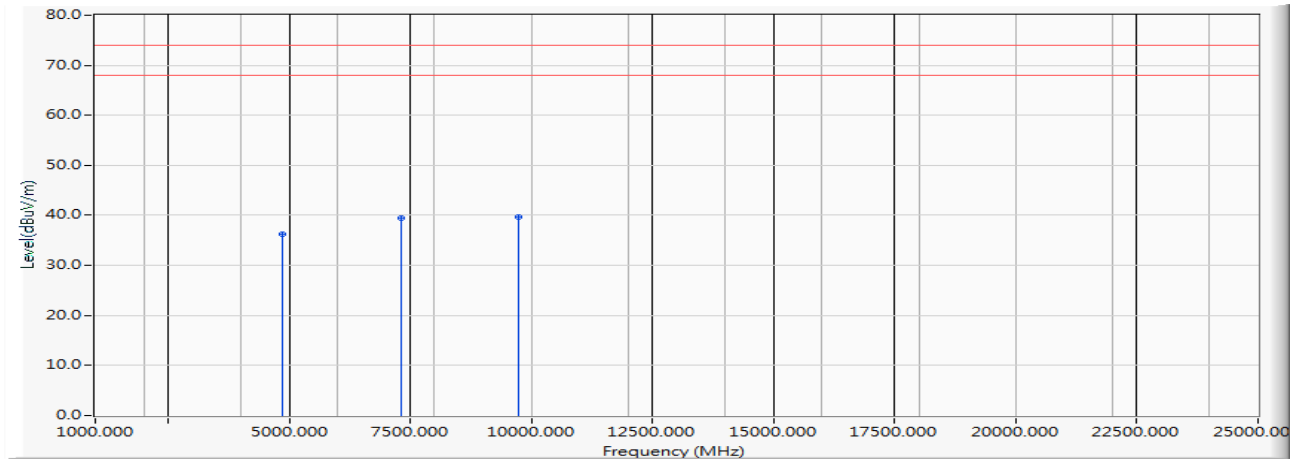

Frequency MHz	Correct Factor dB	Reading Level dB μ V	Measurement Level dB μ V/m	Margin dB	Limit dB μ V/m
Horizontal					
Peak Detector:					
4874.000	6.921	27.267	34.188	-39.812	74.000
7311.000	11.462	27.130	38.592	-35.408	74.000
9748.000	15.194	24.209	39.403	-34.597	74.000
Average Detector:					
--					
Vertical					
Peak Detector:					
4874.000	6.921	29.367	36.288	-37.712	74.000
7311.000	11.462	27.995	39.457	-34.543	74.000
9748.000	15.194	24.522	39.716	-34.284	74.000
Average Detector:					
--					

Note:

1. All Readings below 1GHz are Quasi-Peak, above 1GHz are performed with peak and/or average measurements as necessary.
2. Measurement Level = Reading Level + Correct Factor.
3. Correct Factor = Antenna factor + Cable loss – Amplifier gain.
4. The average measurement was not performed when the peak measured data under the limit of average detection.
5. The emission levels of other frequencies are very lower than the limit and not show in test report.

Product : STREAMING SOUNDBAR
Test Item : Harmonic Radiated Emission Data
Test Site : No.3 OATS
Test Date : 2018/11/01
Test Mode : Mode 3: Transmit (802.11n MCS0 7.2Mbps 20M-BW) (2462 MHz)

Horizontal:

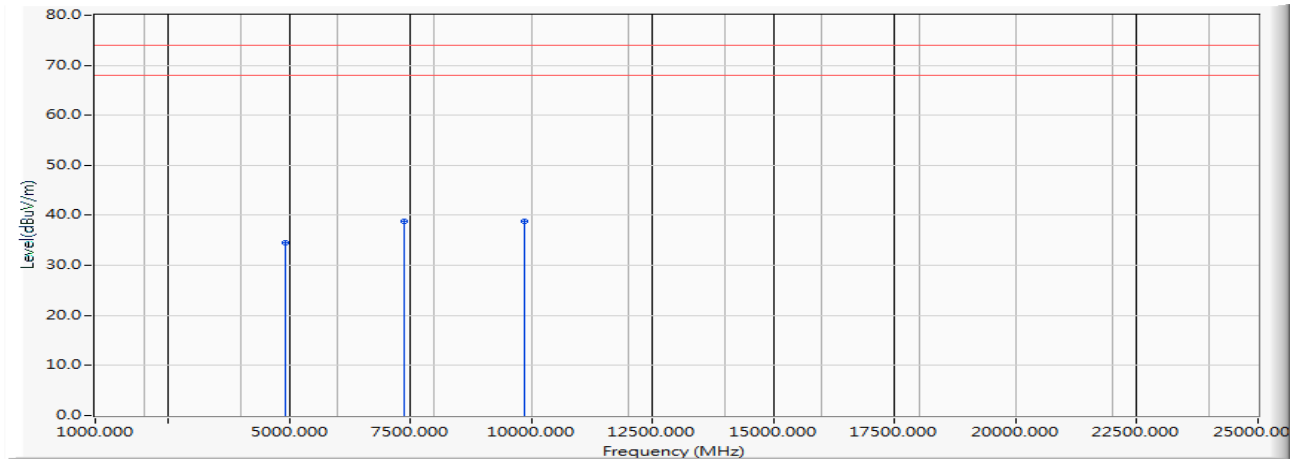

Vertical:

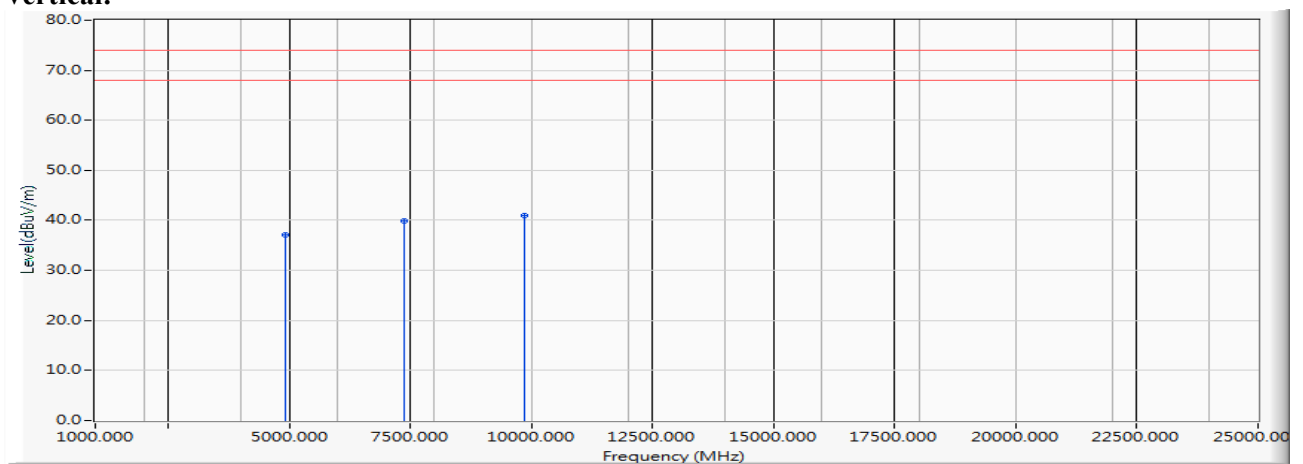

Frequency MHz	Correct Factor dB	Reading Level dB μ V	Measurement Level dB μ V/m	Margin dB	Limit dB μ V/m
Horizontal					
Peak Detector:					
4924.000	6.982	27.487	34.469	-39.531	74.000
7386.000	11.436	27.387	38.823	-35.177	74.000
9848.000	15.087	23.750	38.837	-35.163	74.000
Average Detector:					
--					
Vertical					
Peak Detector:					
4924.000	6.982	30.089	37.071	-36.929	74.000
7386.000	11.436	28.525	39.961	-34.039	74.000
9848.000	15.087	25.876	40.963	-33.037	74.000
Average Detector:					
--					

Note:

1. All Readings below 1GHz are Quasi-Peak, above 1GHz are performed with peak and/or average measurements as necessary.
2. Measurement Level = Reading Level + Correct Factor.
3. Correct Factor = Antenna factor + Cable loss – Amplifier gain.
4. The average measurement was not performed when the peak measured data under the limit of average detection.
5. The emission levels of other frequencies are very lower than the limit and not show in test report.

Product : STREAMING SOUNDBAR
Test Item : Harmonic Radiated Emission Data
Test Site : No.3 OATS
Test Date : 2018/11/01
Test Mode : Mode 4: Transmit (802.11n MCS0 15Mbps 40M-BW)(2422MHz)

Horizontal:

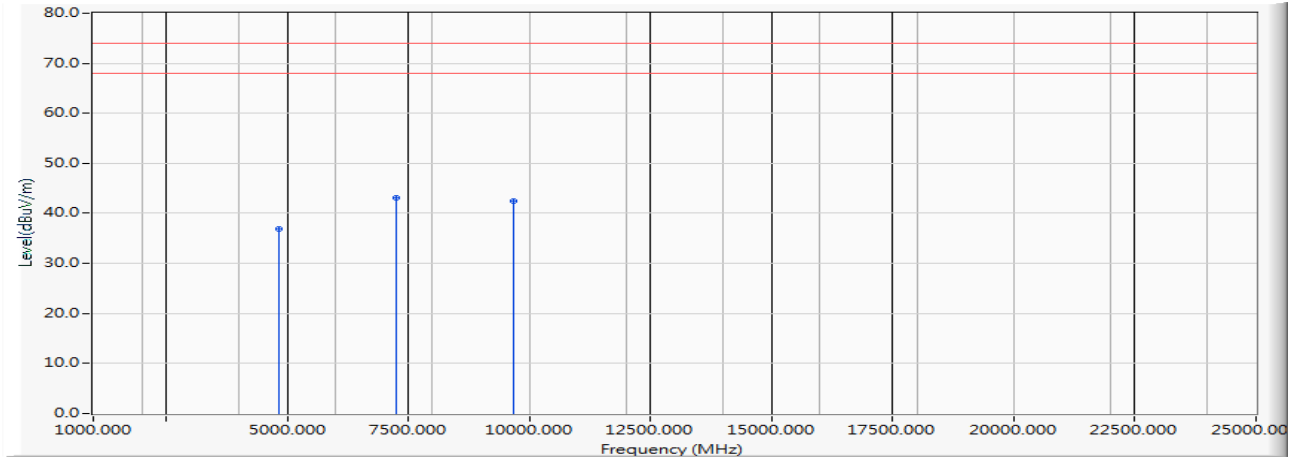

Vertical:

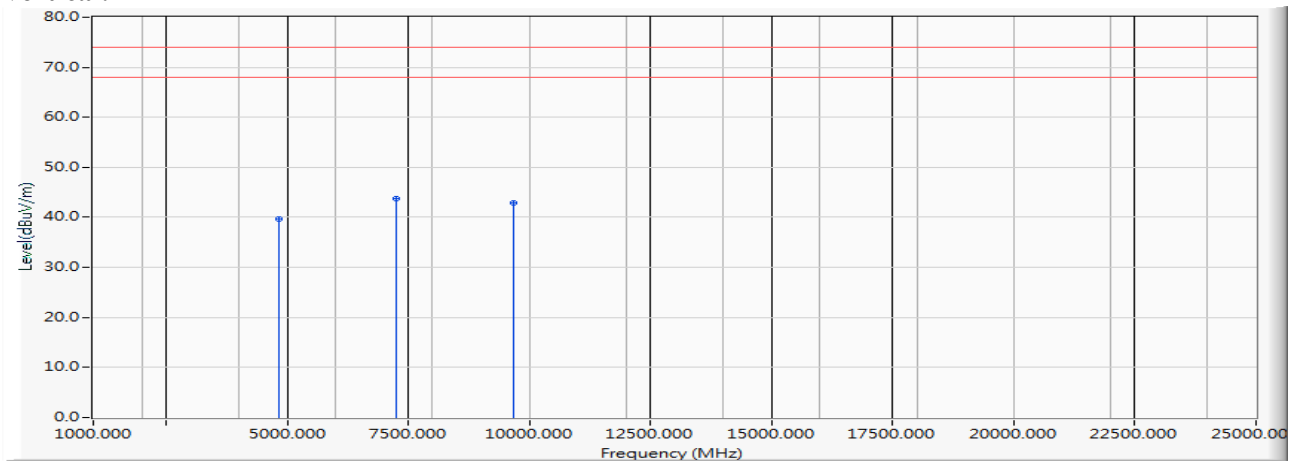

Frequency MHz	Correct Factor dB	Reading Level dB μ V	Measurement Level dB μ V/m	Margin dB	Limit dB μ V/m
Horizontal					
Peak Detector:					
4844.000	6.891	30.073	36.964	-37.036	74.000
7266.000	11.410	31.598	43.009	-30.991	74.000
9688.000	14.884	27.593	42.477	-31.523	74.000
Average Detector:					
--					
Vertical					
Peak Detector:					
4844.000	6.891	32.869	39.760	-34.240	74.000
7266.000	11.410	32.258	43.669	-30.331	74.000
9688.000	14.884	28.006	42.890	-31.110	74.000

Average Detector:

--

Note:

1. All Readings below 1GHz are Quasi-Peak, above 1GHz are performed with peak and/or average measurements as necessary.
2. Measurement Level = Reading Level + Correct Factor.
3. Correct Factor = Antenna factor + Cable loss – Amplifier gain.
4. The average measurement was not performed when the peak measured data under the limit of average detection.
5. The emission levels of other frequencies are very lower than the limit and not show in test report.

Product : STREAMING SOUNDBAR
Test Item : Harmonic Radiated Emission Data
Test Site : No.3 OATS
Test Date : 2018/11/01
Test Mode : Mode 4: Transmit (802.11n MCS0 15Mbps 40M-BW) (2437 MHz)

Horizontal:

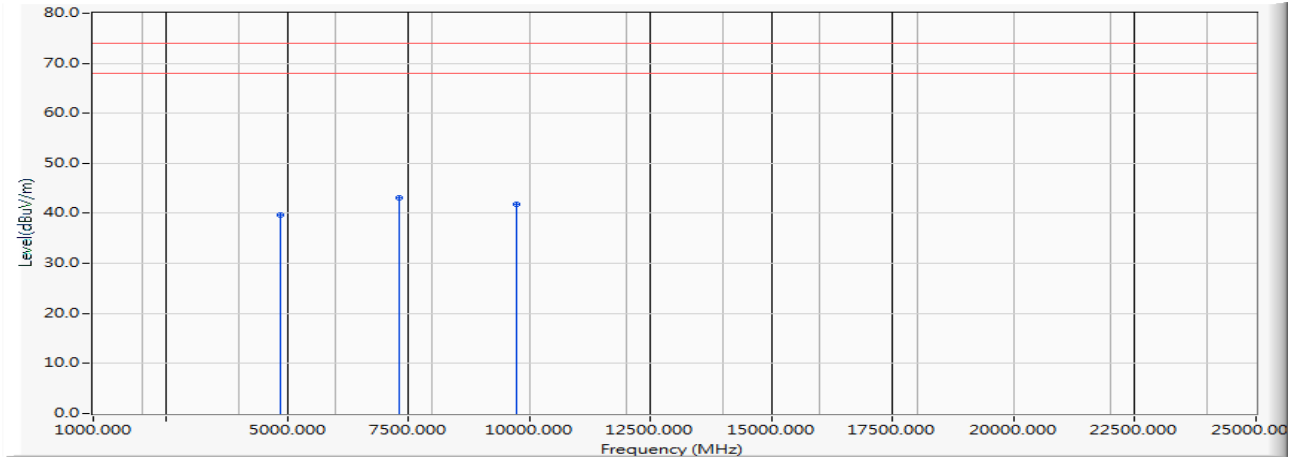

Vertical:

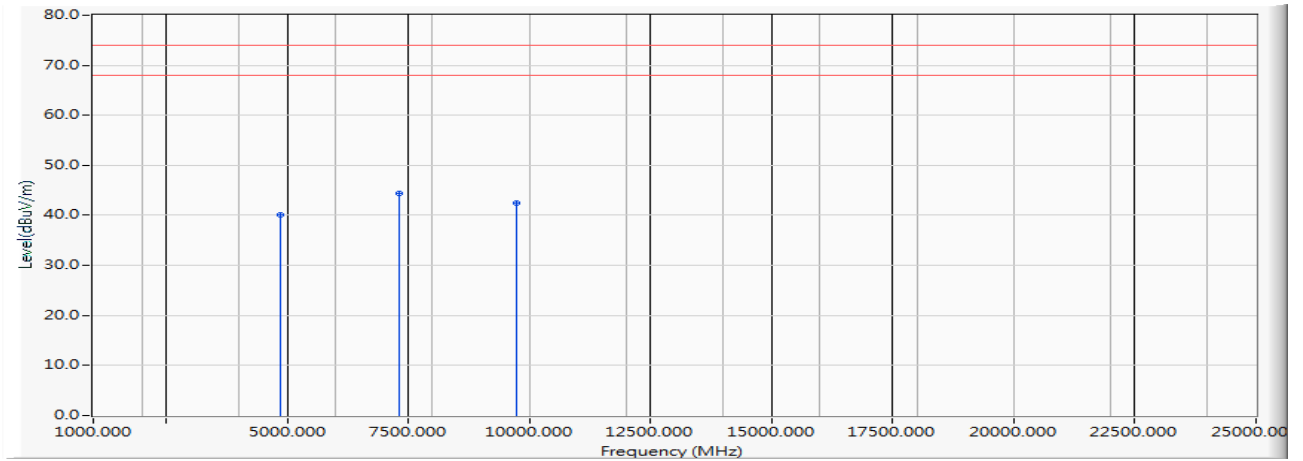

Frequency MHz	Correct Factor dB	Reading Level dB μ V	Measurement Level dB μ V/m	Margin dB	Limit dB μ V/m
Horizontal					
Peak Detector:					
4874.000	6.921	32.701	39.622	-34.378	74.000
7311.000	11.462	31.664	43.126	-30.874	74.000
9748.000	15.194	26.590	41.784	-32.216	74.000
Average Detector:					
--					
Vertical					
Peak Detector:					
4874.000	6.921	33.291	40.212	-33.788	74.000
7311.000	11.462	32.829	44.291	-29.709	74.000
9748.000	15.194	27.181	42.375	-31.625	74.000
Average Detector:					
--					

Note:

1. All Readings below 1GHz are Quasi-Peak, above 1GHz are performed with peak and/or average measurements as necessary.
2. Measurement Level = Reading Level + Correct Factor.
3. Correct Factor = Antenna factor + Cable loss – Amplifier gain.
4. The average measurement was not performed when the peak measured data under the limit of average detection.
5. The emission levels of other frequencies are very lower than the limit and not show in test report.

Product : STREAMING SOUNDBAR
Test Item : Harmonic Radiated Emission Data
Test Site : No.3 OATS
Test Date : 2018/11/01
Test Mode : Mode 4: Transmit (802.11n MCS0 15Mbps 40M-BW)(2452 MHz)

Horizontal:

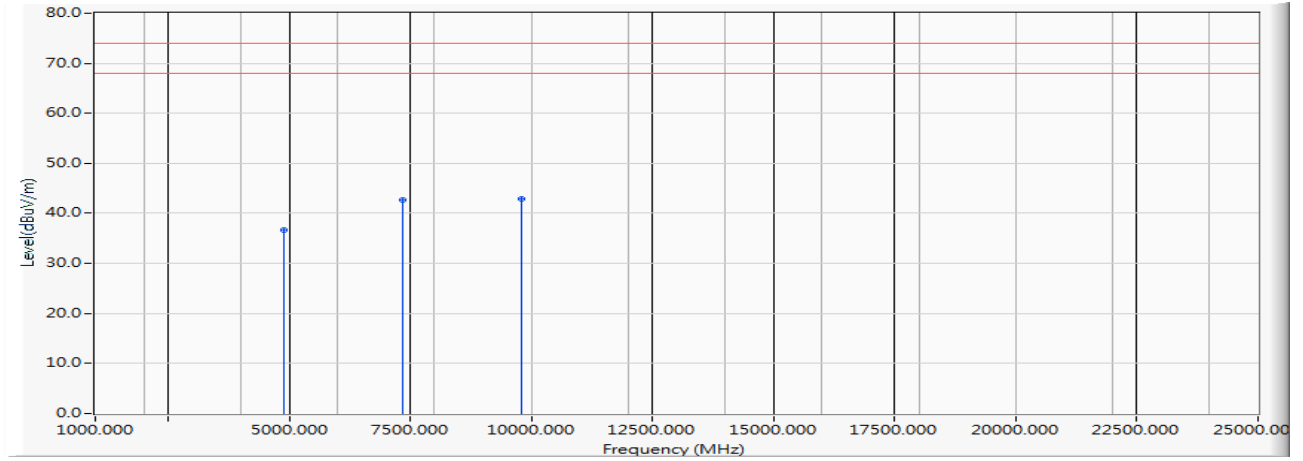

Vertical:

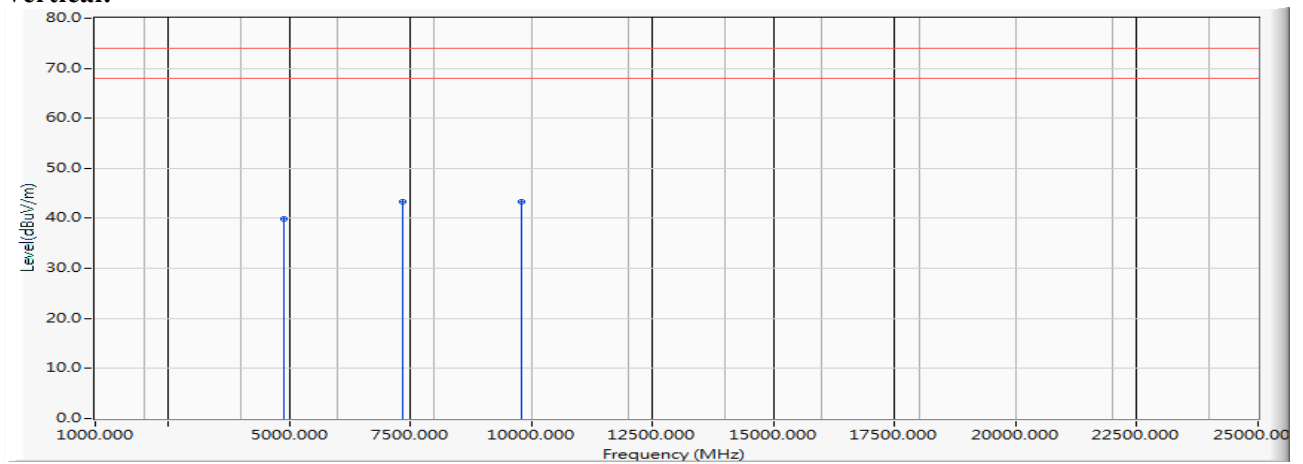

Frequency MHz	Correct Factor dB	Reading Level dB μ V	Measurement Level dB μ V/m	Margin dB	Limit dB μ V/m
Horizontal					
Peak Detector:					
4904.000	6.965	29.710	36.675	-37.325	74.000
7356.000	11.345	31.398	42.743	-31.257	74.000
9808.000	14.971	27.973	42.944	-31.056	74.000
Average Detector:					
--					
Vertical					
Peak Detector:					
4904.000	6.965	32.946	39.911	-34.089	74.000
7356.000	11.345	32.048	43.393	-30.607	74.000
9808.000	14.971	28.369	43.340	-30.660	74.000
Average Detector:					
--					

Note:

1. All Readings below 1GHz are Quasi-Peak, above 1GHz are performed with peak and/or average measurements as necessary.
2. Measurement Level = Reading Level + Correct Factor.
3. Correct Factor = Antenna factor + Cable loss – Amplifier gain.
4. The average measurement was not performed when the peak measured data under the limit of average detection.
5. The emission levels of other frequencies are very lower than the limit and not show in test report.

Product : STREAMING SOUNDBAR
 Test Item : General Radiated Emission Data
 Test Site : No.3 OATS
 Test Date : 2018/11/14
 Test Mode : Mode 1: Transmit (802.11b 1Mbps)(2437 MHz) (DYS602-240250-15714A)

Horizontal:

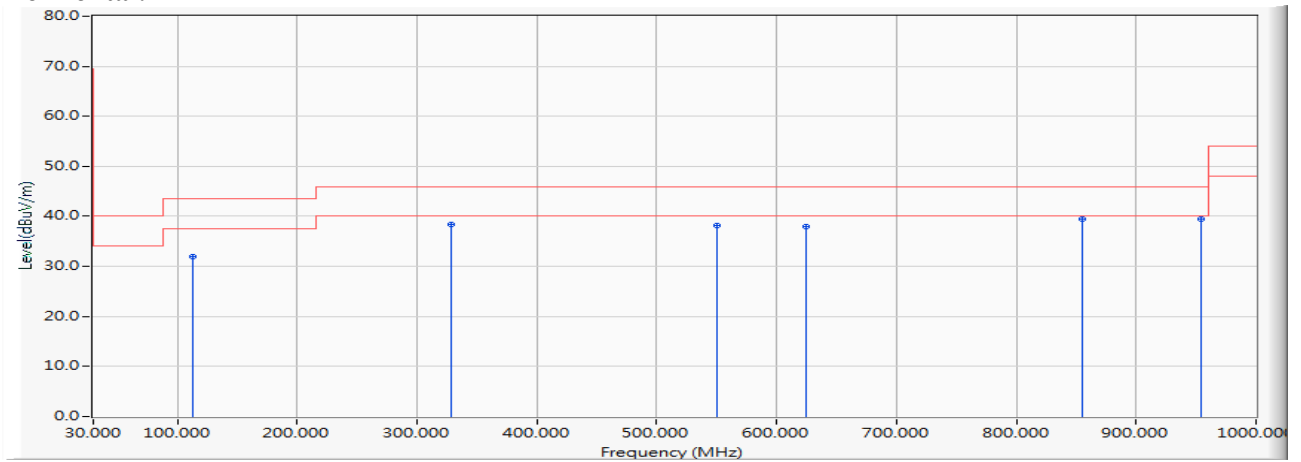

Vertical:

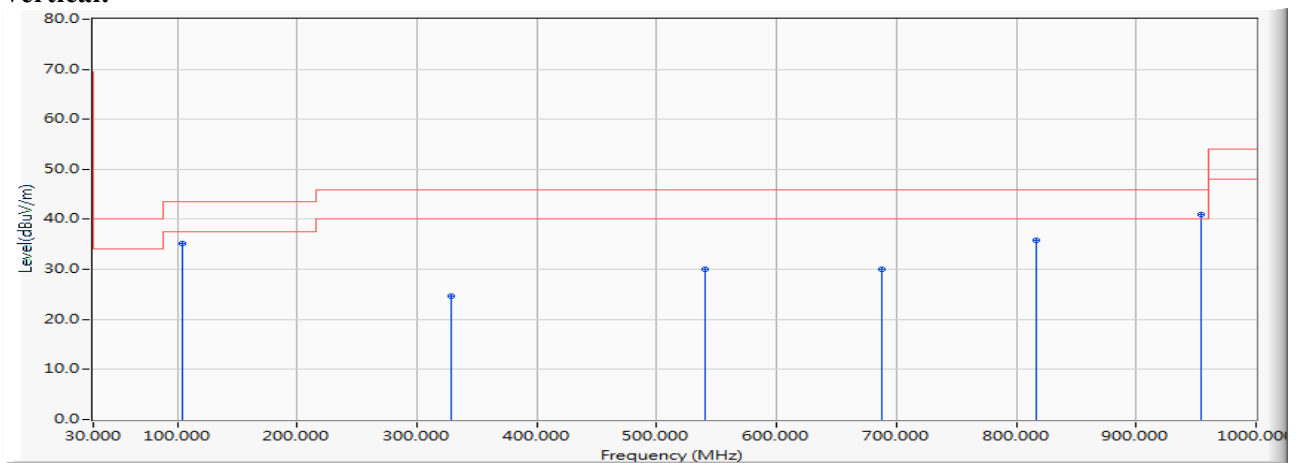

Frequency MHz	Correct Factor dB	Reading Level dB μ V	Measurement Level dB μ V/m	Margin dB	Limit dB μ V/m
Horizontal					
112.942	-13.215	45.151	31.936	-11.564	43.500
328.029	-7.275	45.667	38.392	-7.608	46.000
550.145	0.358	37.726	38.083	-7.917	46.000
624.652	3.103	34.861	37.964	-8.036	46.000
855.203	3.477	35.888	39.365	-6.635	46.000
953.609	6.997	32.532	39.529	-6.471	46.000
Vertical					
104.507	-13.703	48.876	35.173	-8.327	43.500
328.029	-7.275	31.857	24.582	-21.418	46.000
540.304	-0.793	30.786	29.993	-16.007	46.000
687.913	-3.059	33.146	30.087	-15.913	46.000
817.246	3.744	32.072	35.816	-10.184	46.000
953.609	6.997	34.006	41.003	-4.997	46.000

Note:

1. All Readings below 1GHz are Quasi-Peak, above 1GHz are performed with peak and/or average measurements as necessary.
2. Measurement Level = Reading Level + Correct Factor.
3. Correct Factor = Antenna factor + Cable loss – Amplifier gain.
4. The emission levels of other frequencies are very lower than the limit and not show in test report.
5. No emission found between lowest internal used/generated frequency to 30MHz.

Product : STREAMING SOUNDBAR
Test Item : General Radiated Emission Data
Test Site : No.3 OATS
Test Date : 2018/11/14
Test Mode : Mode 2: Transmit (802.11g 6Mbps)(2437 MHz) (DYS602-240250-15714A)

Horizontal:

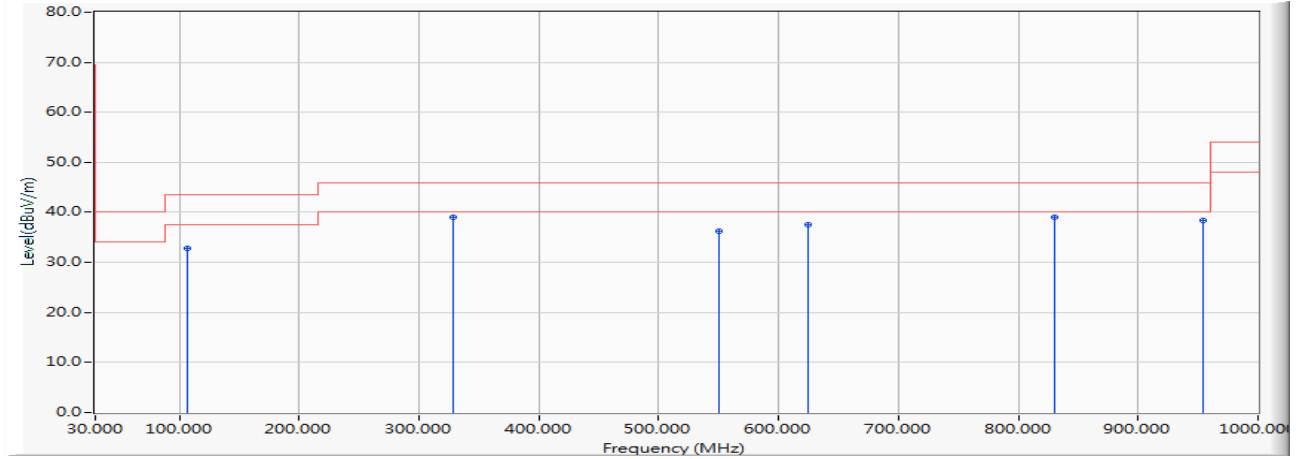

Vertical:

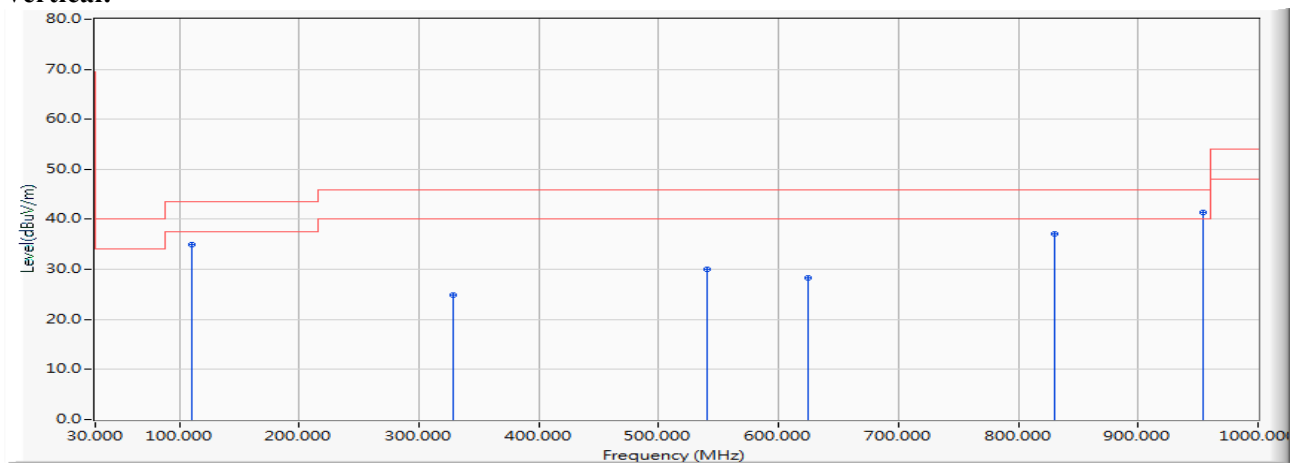

Frequency MHz	Correct Factor dB	Reading Level dB μ V	Measurement Level dB μ V/m	Margin dB	Limit dB μ V/m
Horizontal					
107.319	-13.870	46.733	32.864	-10.636	43.500
328.029	-7.275	46.274	38.999	-7.001	46.000
550.145	0.358	35.835	36.192	-9.808	46.000
624.652	3.103	34.427	37.530	-8.470	46.000
829.899	3.548	35.564	39.112	-6.888	46.000
953.609	6.997	31.384	38.381	-7.619	46.000
Vertical					
110.130	-13.932	48.870	34.937	-8.563	43.500
328.029	-7.275	32.195	24.920	-21.080	46.000
540.304	-0.793	30.892	30.099	-15.901	46.000
624.652	3.103	25.124	28.227	-17.773	46.000
829.899	3.548	33.492	37.040	-8.960	46.000
953.609	6.997	34.293	41.290	-4.710	46.000

Note:

1. All Readings below 1GHz are Quasi-Peak, above 1GHz are performed with peak and/or average measurements as necessary.
2. Measurement Level = Reading Level + Correct Factor.
3. Correct Factor = Antenna factor + Cable loss – Amplifier gain.
4. The emission levels of other frequencies are very lower than the limit and not show in test report.
5. No emission found between lowest internal used/generated frequency to 30MHz.

Product : STREAMING SOUNDBAR
 Test Item : General Radiated Emission Data
 Test Site : No.3 OATS
 Test Date : 2018/11/14
 Test Mode : Mode 3: Transmit (802.11n MCS0 7.2Mbps 20M-BW)(2437 MHz)
 (DYS602-240250-15714A)

Horizontal:

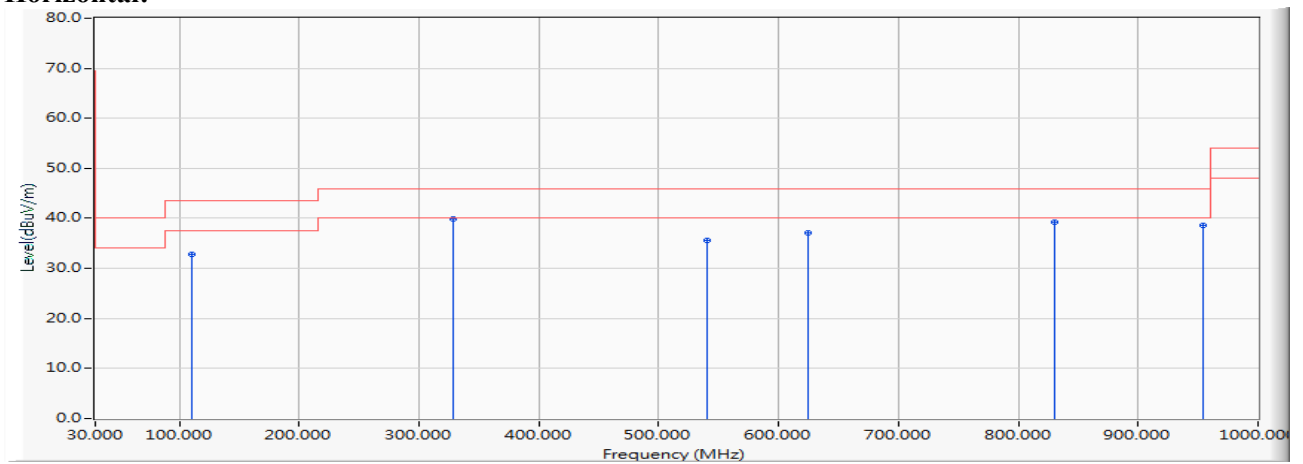

Vertical:

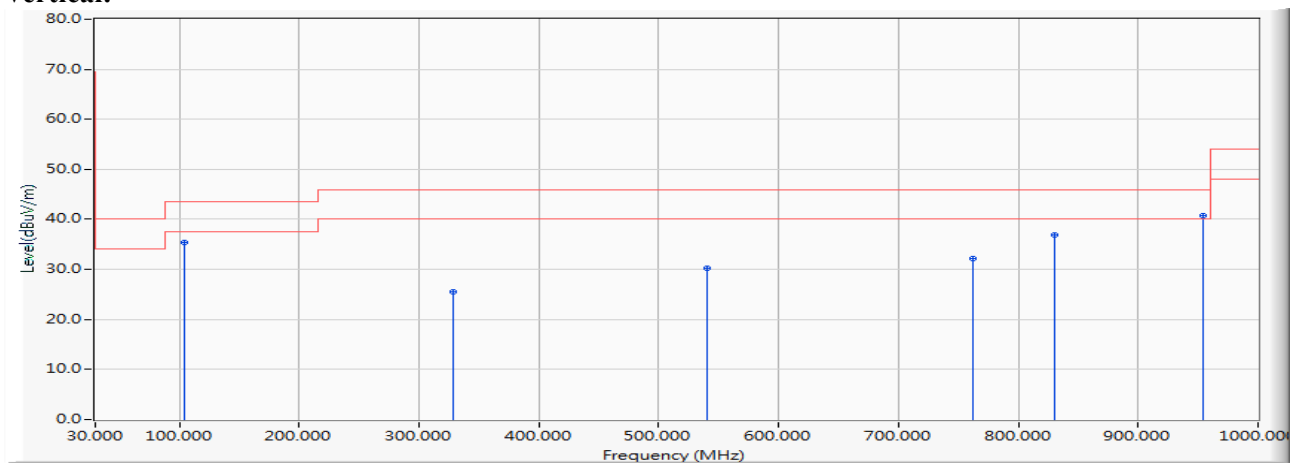

Frequency MHz	Correct Factor dB	Reading Level dB μ V	Measurement Level dB μ V/m	Margin dB	Limit dB μ V/m
Horizontal					
110.130	-13.932	46.852	32.919	-10.581	43.500
328.029	-7.275	47.240	39.965	-6.035	46.000
540.304	-0.793	36.312	35.519	-10.481	46.000
624.652	3.103	34.017	37.120	-8.880	46.000
829.899	3.548	35.662	39.210	-6.790	46.000
953.609	6.997	31.576	38.573	-7.427	46.000
Vertical					
104.507	-13.703	49.038	35.335	-8.165	43.500
328.029	-7.275	32.904	25.629	-20.371	46.000
540.304	-0.793	31.112	30.319	-15.681	46.000
762.420	2.747	29.337	32.083	-13.917	46.000
829.899	3.548	33.419	36.967	-9.033	46.000
953.609	6.997	33.806	40.803	-5.197	46.000

Note:

1. All Readings below 1GHz are Quasi-Peak, above 1GHz are performed with peak and/or average measurements as necessary.
2. Measurement Level = Reading Level + Correct Factor.
3. Correct Factor = Antenna factor + Cable loss – Amplifier gain.
4. The emission levels of other frequencies are very lower than the limit and not show in test report.
5. No emission found between lowest internal used/generated frequency to 30MHz.

Product : STREAMING SOUNDBAR
Test Item : General Radiated Emission Data
Test Site : No.3 OATS
Test Date : 2018/12/07
Test Mode : Mode 4: Transmit (802.11n MCS0 15Mbps 40M-BW)(2437 MHz)
(DYS602-240250-15714A)

Horizontal:

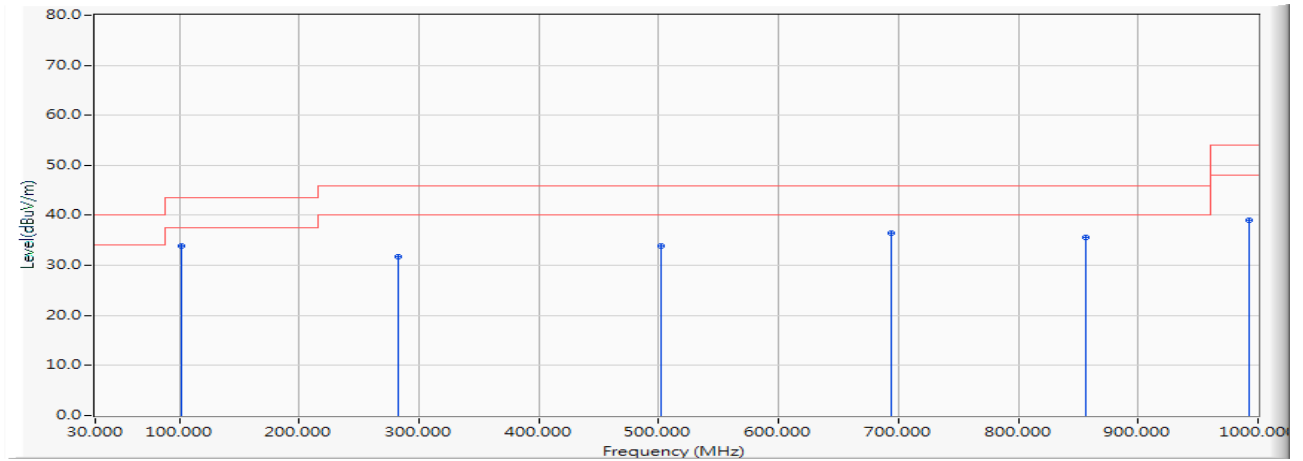

Vertical:

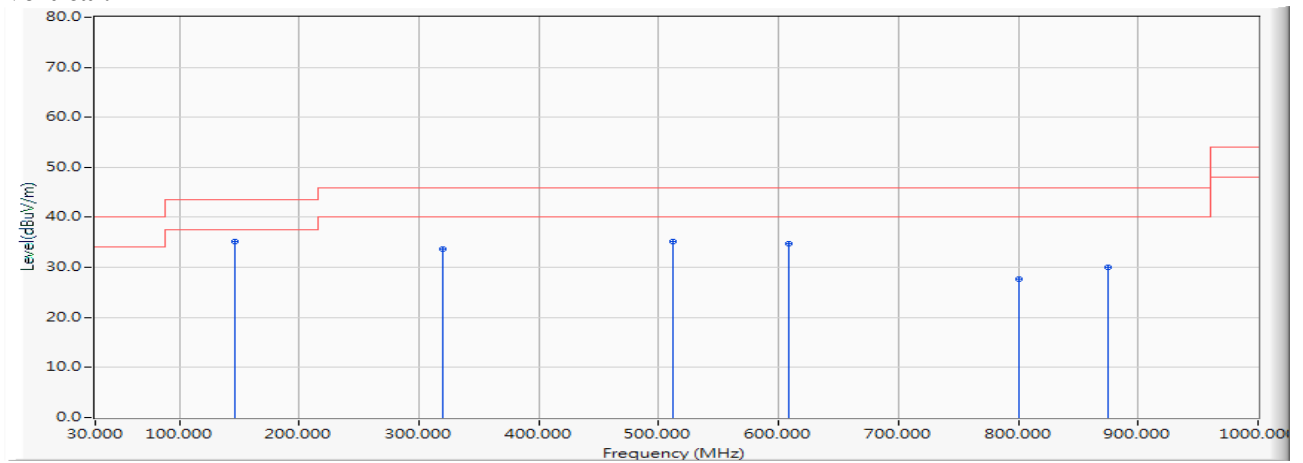

Frequency MHz	Correct Factor dB	Reading Level dB μ V	Measurement Level dB μ V/m	Margin dB	Limit dB μ V/m
Horizontal					
101.780	-13.541	47.464	33.923	-9.577	43.500
282.200	-6.288	38.105	31.817	-14.183	46.000
501.420	-2.498	36.360	33.862	-12.138	46.000
693.480	-3.034	39.471	36.437	-9.563	46.000
856.440	3.470	32.085	35.555	-10.445	46.000
992.240	9.862	29.134	38.996	-15.004	54.000
Vertical					
146.400	-3.222	38.471	35.249	-8.251	43.500
320.030	-7.342	41.098	33.756	-12.244	46.000
512.090	-1.219	36.300	35.081	-10.919	46.000
608.120	3.297	31.345	34.642	-11.358	46.000
800.180	3.354	24.227	27.581	-18.419	46.000
874.870	4.821	25.275	30.096	-15.904	46.000

Note:

1. All Readings below 1GHz are Quasi-Peak, above 1GHz are performed with peak and/or average measurements as necessary.
2. Measurement Level = Reading Level + Correct Factor.
3. Correct Factor = Antenna factor + Cable loss – Amplifier gain.
4. The emission levels of other frequencies are very lower than the limit and not show in test report.
5. No emission found between lowest internal used/generated frequency to 30MHz.

Product : STREAMING SOUNDBAR
 Test Item : General Radiated Emission Data
 Test Site : No.3 OATS
 Test Date : 2018/12/20
 Test Mode : Mode 1: Transmit (802.11b 1Mbps)(2437 MHz) (F150602-A)

Horizontal:

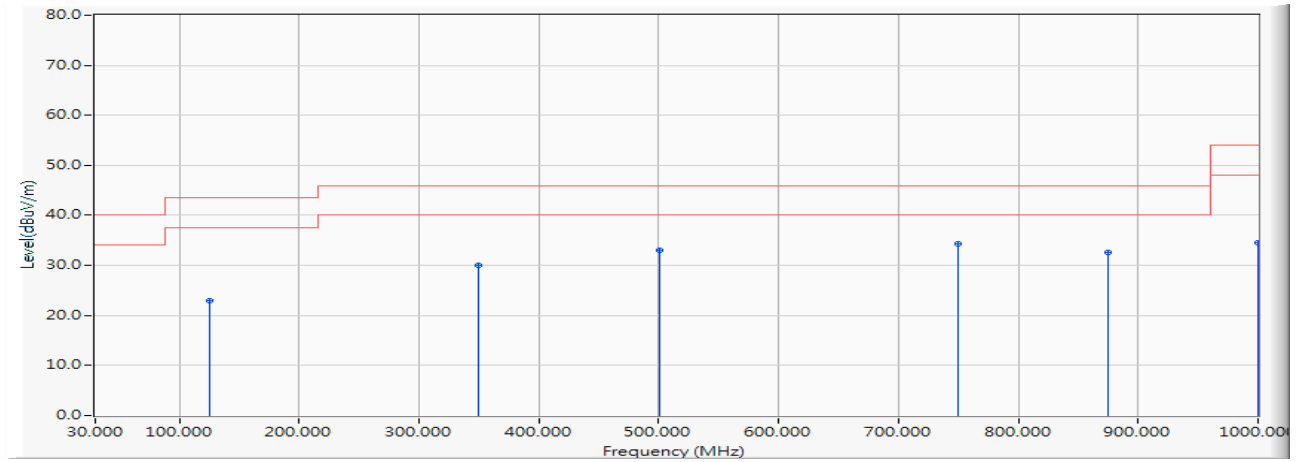

Vertical:

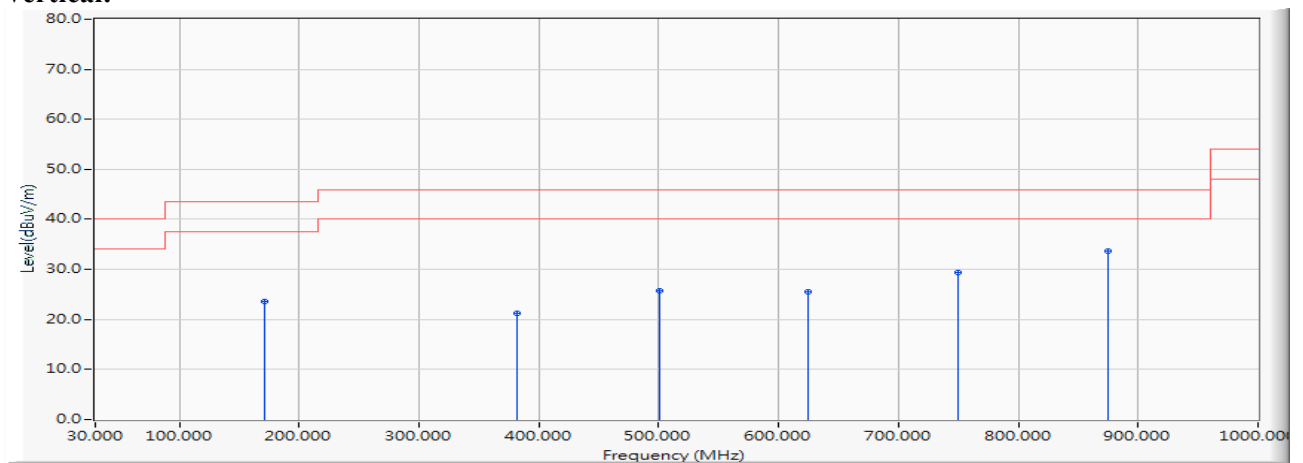

Frequency MHz	Correct Factor dB	Reading Level dB μ V	Measurement Level dB μ V/m	Margin dB	Limit dB μ V/m
Horizontal					
125.060	-8.411	31.365	22.954	-20.546	43.500
350.100	-7.089	37.038	29.949	-16.051	46.000
500.450	-2.601	35.626	33.025	-12.975	46.000
749.740	2.843	31.580	34.423	-11.577	46.000
874.870	4.821	27.760	32.581	-13.419	46.000
1000.000	9.639	24.891	34.530	-19.470	54.000
Vertical					
171.620	-3.762	27.336	23.574	-19.926	43.500
382.110	-5.750	26.953	21.203	-24.797	46.000
500.450	-2.601	28.249	25.648	-20.352	46.000
624.610	3.104	22.521	25.625	-20.375	46.000
749.740	2.843	26.468	29.311	-16.689	46.000
874.870	4.821	28.776	33.597	-12.403	46.000

Note:

1. All Readings below 1GHz are Quasi-Peak, above 1GHz are performed with peak and/or average measurements as necessary.
2. Measurement Level = Reading Level + Correct Factor.
3. Correct Factor = Antenna factor + Cable loss – Amplifier gain.
4. The emission levels of other frequencies are very lower than the limit and not show in test report.
5. No emission found between lowest internal used/generated frequency to 30MHz.

Product : STREAMING SOUNDBAR
Test Item : General Radiated Emission Data
Test Site : No.3 OATS
Test Date : 2018/12/20
Test Mode : Mode 2: Transmit (802.11g 6Mbps)(2437 MHz) (F150602-A)

Horizontal:

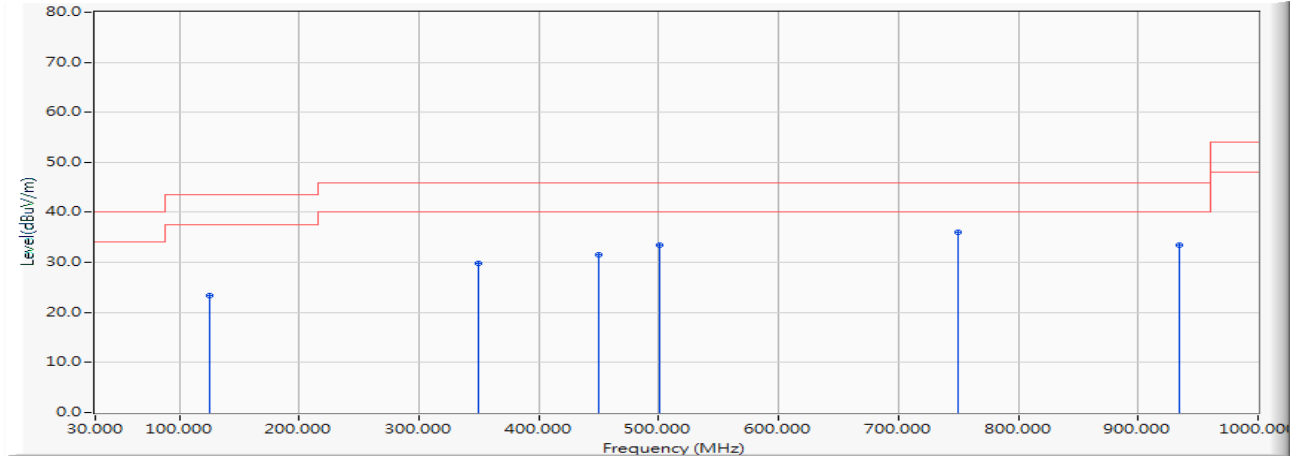

Vertical:

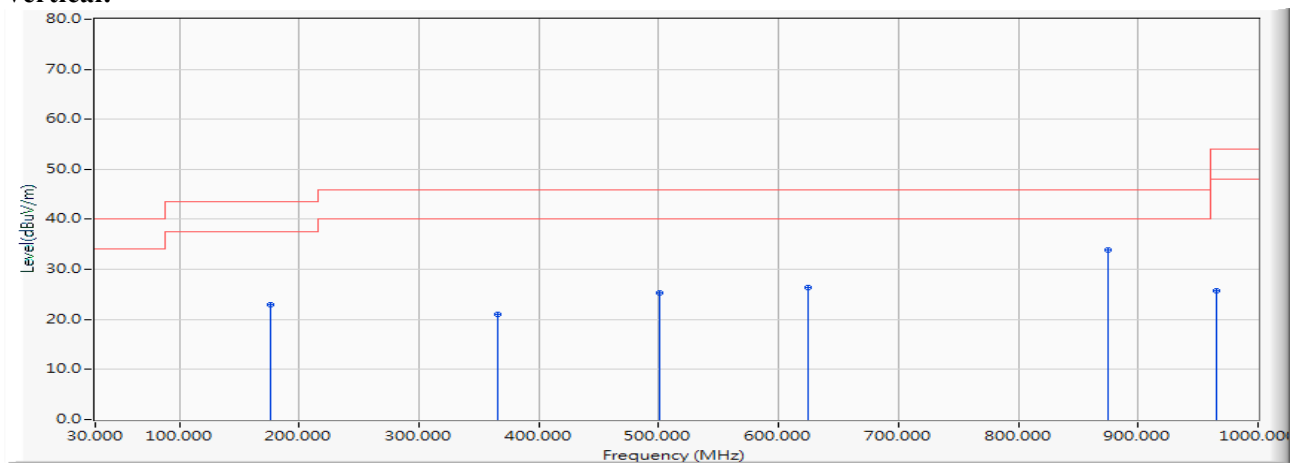

Frequency MHz	Correct Factor dB	Reading Level dB μ V	Measurement Level dB μ V/m	Margin dB	Limit dB μ V/m
Horizontal					
125.060	-8.411	31.857	23.446	-20.054	43.500
350.100	-7.089	36.868	29.779	-16.221	46.000
450.010	-4.251	35.760	31.509	-14.491	46.000
500.450	-2.601	36.069	33.468	-12.532	46.000
749.740	2.843	33.284	36.127	-9.873	46.000
934.040	6.785	26.733	33.518	-12.482	46.000
Vertical					
176.470	-4.185	27.055	22.870	-20.630	43.500
365.620	-6.363	27.306	20.943	-25.057	46.000
500.450	-2.601	27.849	25.248	-20.752	46.000
624.610	3.104	23.233	26.337	-19.663	46.000
874.870	4.821	29.083	33.904	-12.096	46.000
965.080	7.681	18.048	25.729	-28.271	54.000

Note:

1. All Readings below 1GHz are Quasi-Peak, above 1GHz are performed with peak and/or average measurements as necessary.
2. Measurement Level = Reading Level + Correct Factor.
3. Correct Factor = Antenna factor + Cable loss – Amplifier gain.
4. The emission levels of other frequencies are very lower than the limit and not show in test report.
5. No emission found between lowest internal used/generated frequency to 30MHz.

Product : STREAMING SOUNDBAR
Test Item : General Radiated Emission Data
Test Site : No.3 OATS
Test Date : 2018/12/20
Test Mode : Mode 3: Transmit (802.11n MCS0 7.2Mbps 20M-BW)(2437 MHz) (F150602-A)

Horizontal:

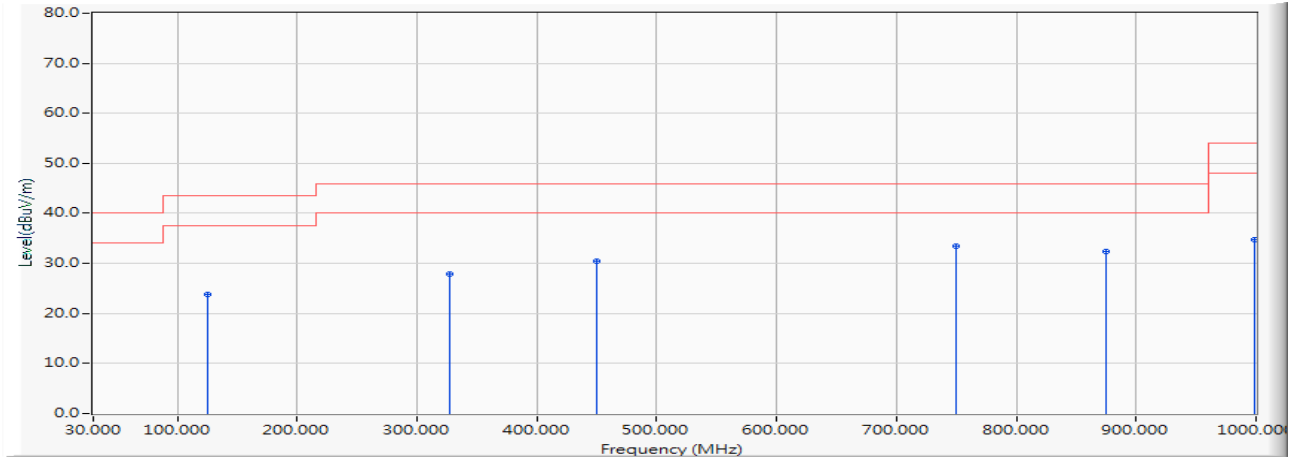

Vertical:

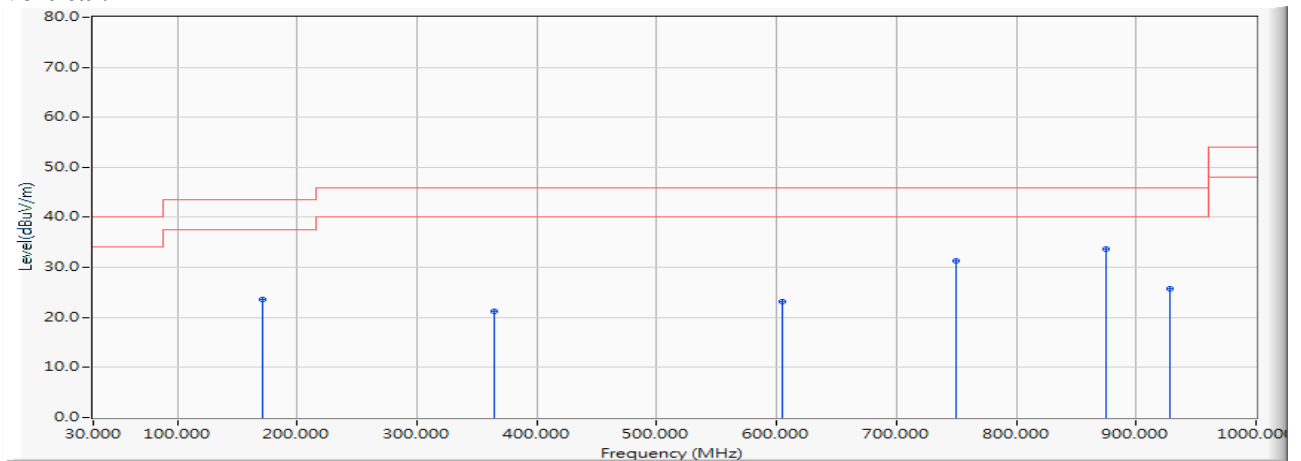

Frequency MHz	Correct Factor dB	Reading Level dB μ V	Measurement Level dB μ V/m	Margin dB	Limit dB μ V/m
Horizontal					
125.060	-8.411	32.111	23.700	-19.800	43.500
327.790	-7.276	35.141	27.865	-18.135	46.000
450.010	-4.251	34.703	30.452	-15.548	46.000
749.740	2.843	30.509	33.352	-12.648	46.000
874.870	4.821	27.537	32.358	-13.642	46.000
999.030	9.667	25.018	34.685	-19.315	54.000
Vertical					
171.620	-3.762	27.331	23.569	-19.931	43.500
364.650	-6.406	27.537	21.131	-24.869	46.000
605.210	3.340	19.724	23.064	-22.936	46.000
749.740	2.843	28.403	31.246	-14.754	46.000
874.870	4.821	28.929	33.750	-12.250	46.000
928.220	6.680	19.163	25.843	-20.157	46.000

Note:

1. All Readings below 1GHz are Quasi-Peak, above 1GHz are performed with peak and/or average measurements as necessary.
2. Measurement Level = Reading Level + Correct Factor.
3. Correct Factor = Antenna factor + Cable loss – Amplifier gain.
4. The emission levels of other frequencies are very lower than the limit and not show in test report.
5. No emission found between lowest internal used/generated frequency to 30MHz.

Product : STREAMING SOUNDBAR
Test Item : General Radiated Emission Data
Test Site : No.3 OATS
Test Date : 2018/12/20
Test Mode : Mode 4: Transmit (802.11n MCS0 15Mbps 40M-BW)(2437 MHz) (F150602-A)

Horizontal:

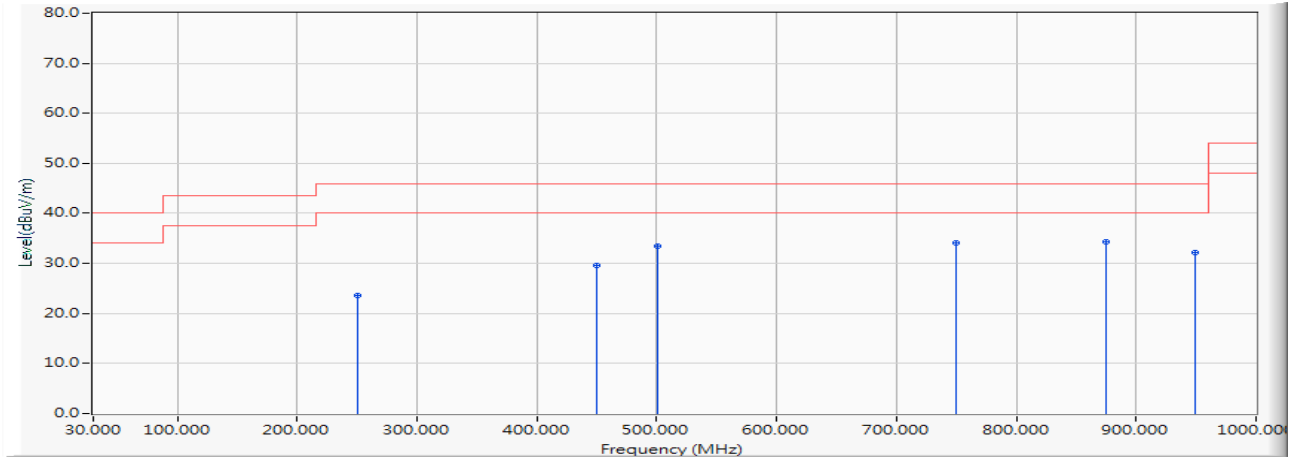

Vertical:

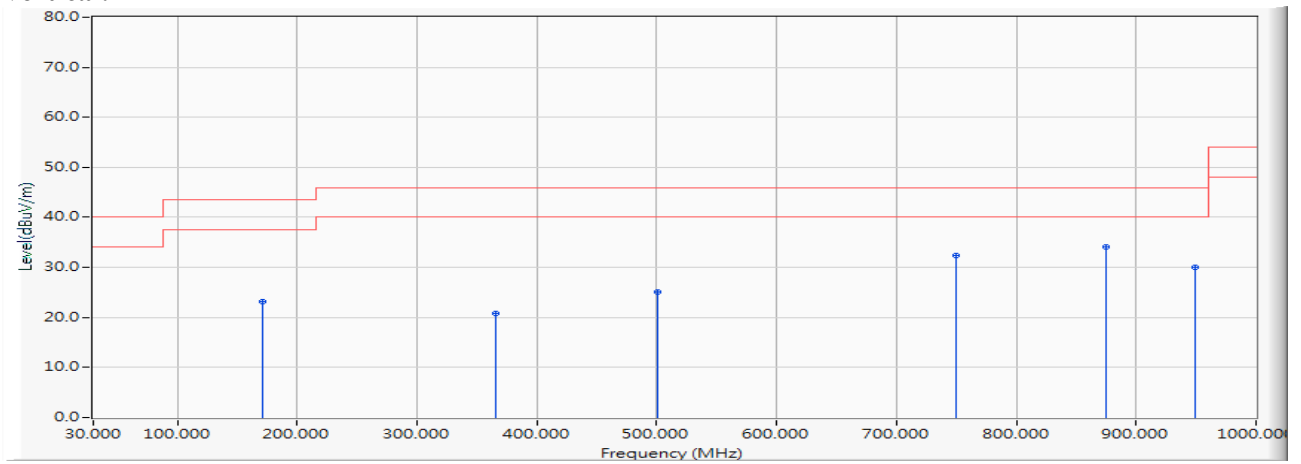

Frequency MHz	Correct Factor dB	Reading Level dB μ V	Measurement Level dB μ V/m	Margin dB	Limit dB μ V/m
Horizontal					
250.190	-6.410	29.992	23.582	-22.418	46.000
450.010	-4.251	33.777	29.526	-16.474	46.000
500.450	-2.601	36.158	33.557	-12.443	46.000
749.740	2.843	31.226	34.069	-11.931	46.000
874.870	4.821	29.567	34.388	-11.612	46.000
949.560	7.085	25.186	32.271	-13.729	46.000
Vertical					
171.620	-3.762	26.846	23.084	-20.416	43.500
365.620	-6.363	27.082	20.719	-25.281	46.000
500.450	-2.601	27.737	25.136	-20.864	46.000
749.740	2.843	29.454	32.297	-13.703	46.000
874.870	4.821	29.265	34.086	-11.914	46.000
949.560	7.085	22.897	29.982	-16.018	46.000

Note:

1. All Readings below 1GHz are Quasi-Peak, above 1GHz are performed with peak and/or average measurements as necessary.
2. Measurement Level = Reading Level + Correct Factor.
3. Correct Factor = Antenna factor + Cable loss – Amplifier gain.
4. The emission levels of other frequencies are very lower than the limit and not show in test report.
5. No emission found between lowest internal used/generated frequency to 30MHz.

5. RF antenna conducted test

5.1. Test Setup

RF antenna Conducted Measurement:

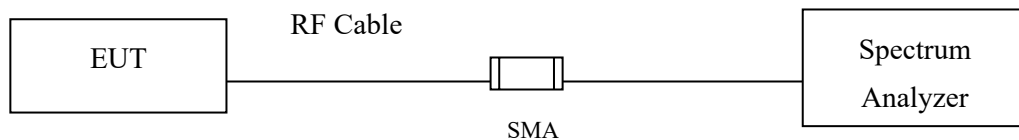

5.2. Limits

In any 100 kHz bandwidth outside the frequency band in which the spread spectrum intentional radiator is operating, the radio frequency power that is produced by the intentional radiator shall be at least 20 dB below that in the 100 kHz bandwidth within the band that contains the highest level of the desired power, based on either an RF conducted or a radiated measurement. Attenuation below the general limits specified in Section 15.209(a) is not required. In addition, radiated emissions which fall in the restricted bands, as defined in Section 15.205(a), must also comply with the radiated emission limits specified in Section 15.209(a) (see Section 15.205(c)).

5.3. Test Procedure

The EUT was tested according to DTS test procedure of KDB558074 for compliance to FCC 47CFR 15.247 requirements.

Set RBW = 100 kHz, Set VBW > RBW, scan up through 10th harmonic.

5.4. Uncertainty

The measurement uncertainty

Conducted is defined as $\pm 1.20\text{dB}$

5.5. Test Result of RF antenna conducted test

Product : STREAMING SOUNDBAR
 Test Item : RF antenna conducted test
 Test Site : No.3 OATS
 Test Date : 2018/10/30
 Test Mode : Mode 1: Transmit (802.11b 1Mbps)

Channel 01 (2412MHz)

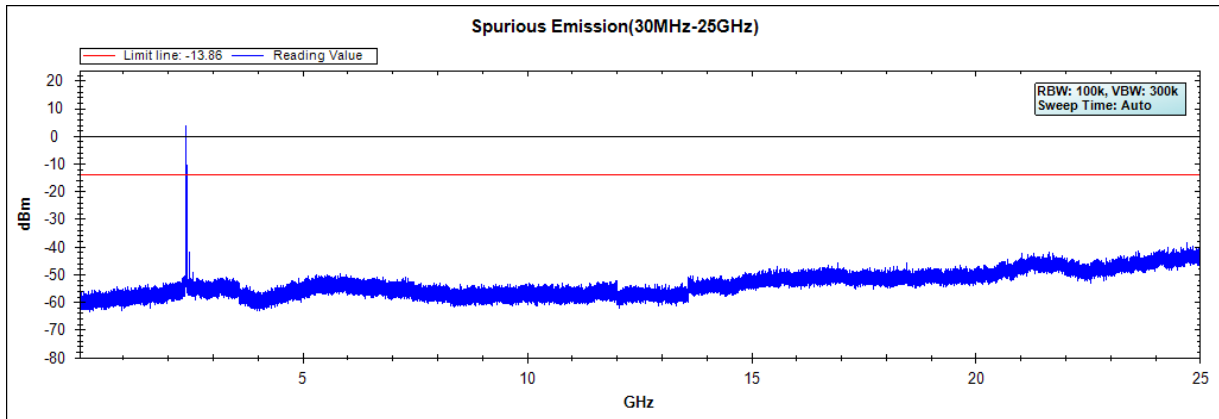

Channel 06 (2437MHz)

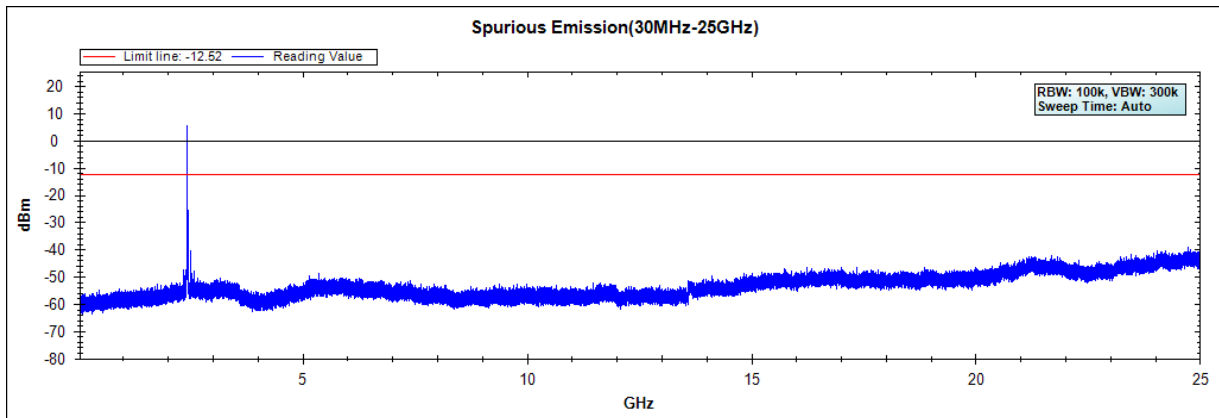

Channel 11 (2462MHz)

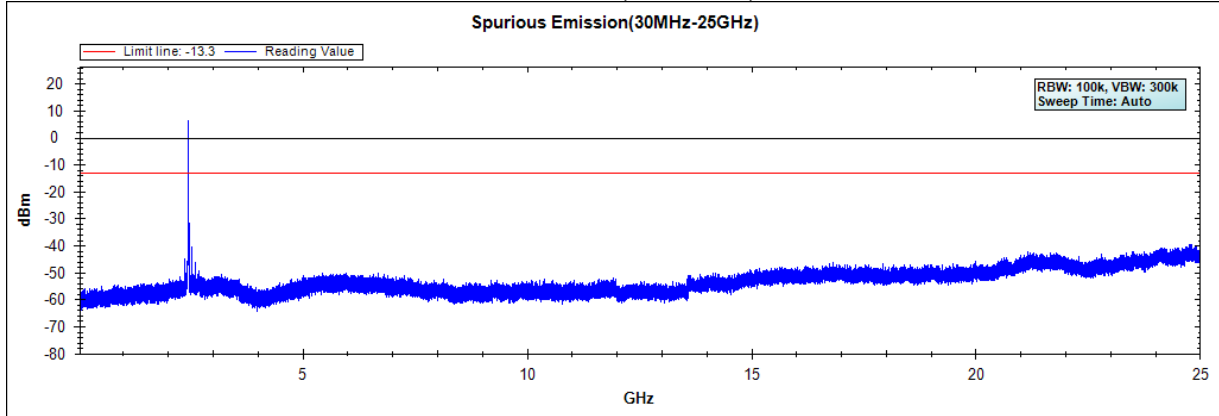

Note: The above test pattern is synthesized by multiple of the frequency range.

Product : STREAMING SOUNDBAR
Test Item : RF Antenna Conducted Spurious
Test Site : No.3 OATS
Test Date : 2018/10/30
Test Mode : Mode 2: Transmit (802.11g 6Mbps)

Channel 01 (2412MHz)

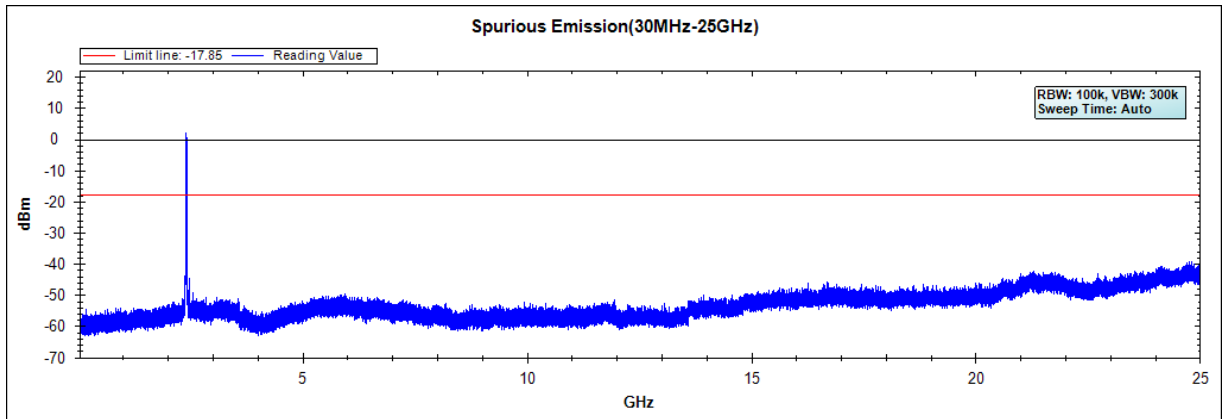

Channel 06 (2437MHz)

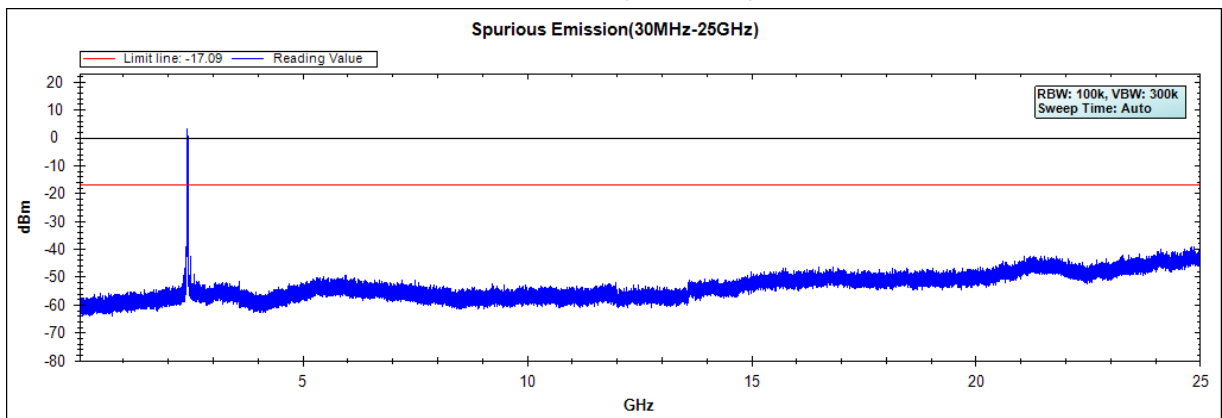

Channel 11 (2462MHz)

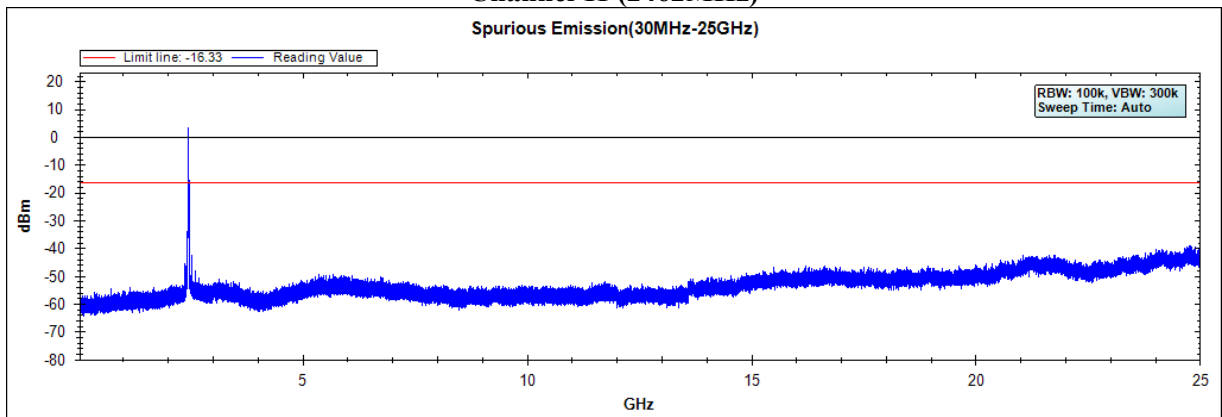

Note: The above test pattern is synthesized by multiple of the frequency range.

Product : STREAMING SOUNDBAR
Test Item : RF Antenna Conducted Spurious
Test Site : No.3 OATS
Test Date : 2018/10/30
Test Mode : Mode 3: Transmit (802.11n MCS0 7.2Mbps 20M-BW)

Channel 01 (2412MHz)

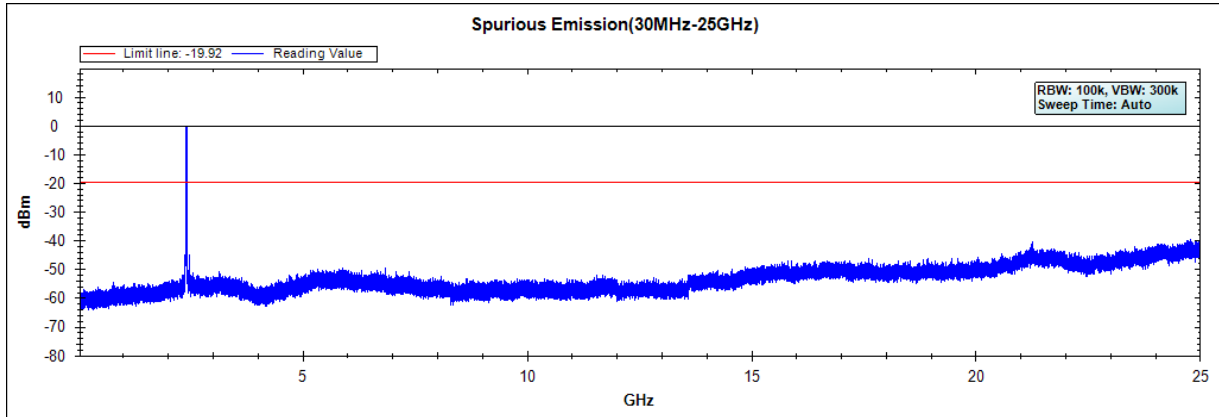

Channel 06 (2437MHz)

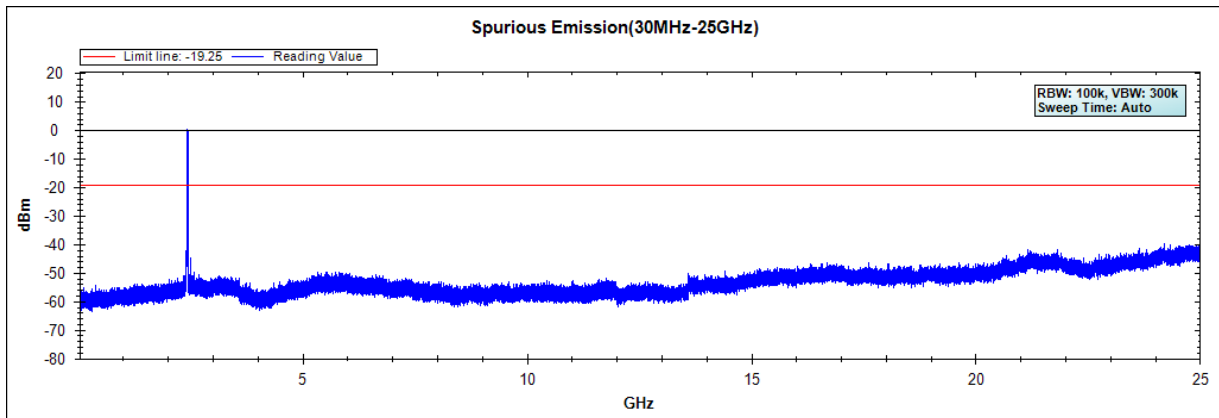

Channel 11 (2462MHz)

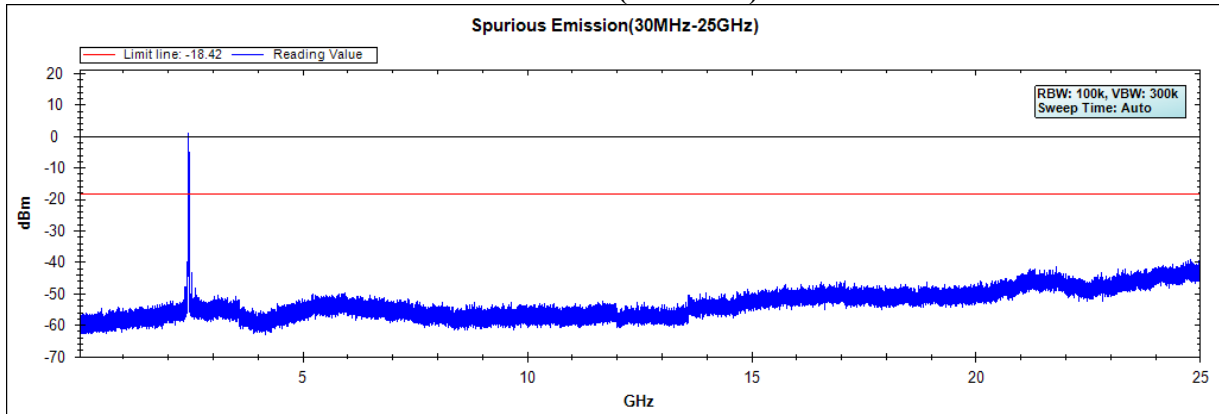

Note: The above test pattern is synthesized by multiple of the frequency range.

Product : STREAMING SOUNDBAR
Test Item : RF Antenna Conducted Spurious
Test Site : No.3 OATS
Test Date : 2018/12/11
Test Mode : Mode 4: Transmit (802.11n MCS0 15Mbps 40M-BW)

Channel 01 (2422MHz)

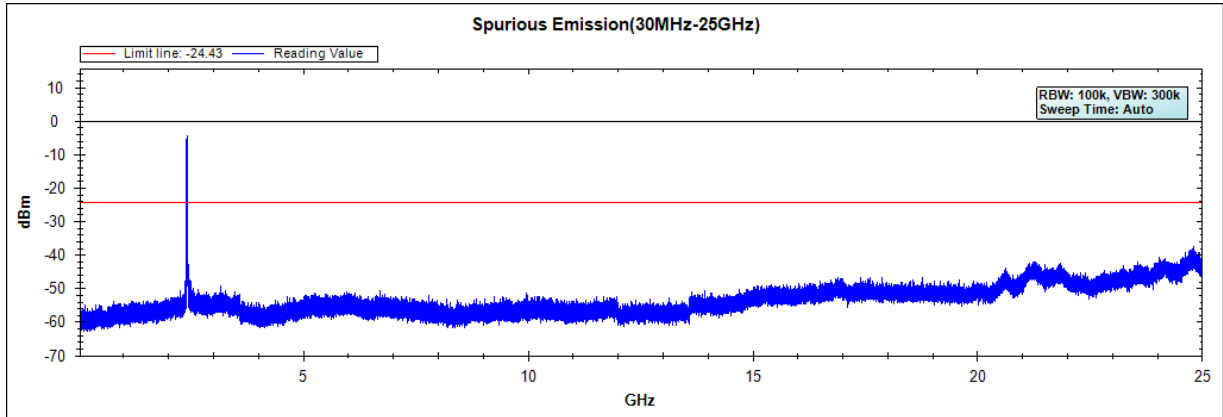

Channel 04 (2437MHz)

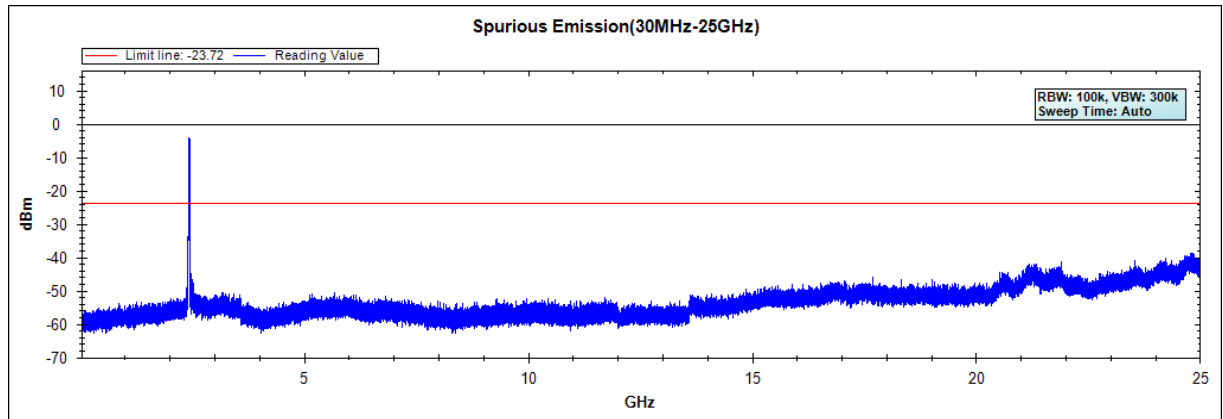

Channel 07 (2452MHz)

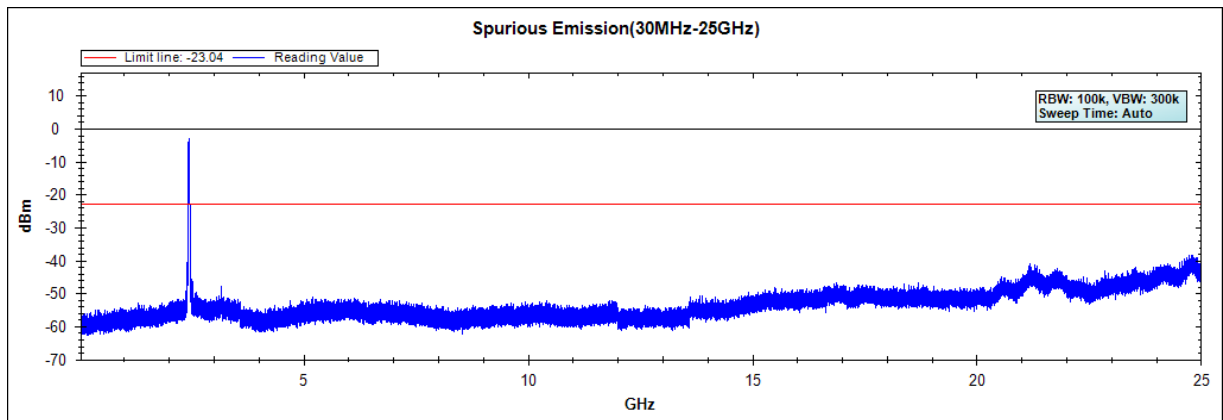

Note: The above test pattern is synthesized by multiple of the frequency range.

6. Band Edge

6.1. Test Setup

RF Radiated Measurement:

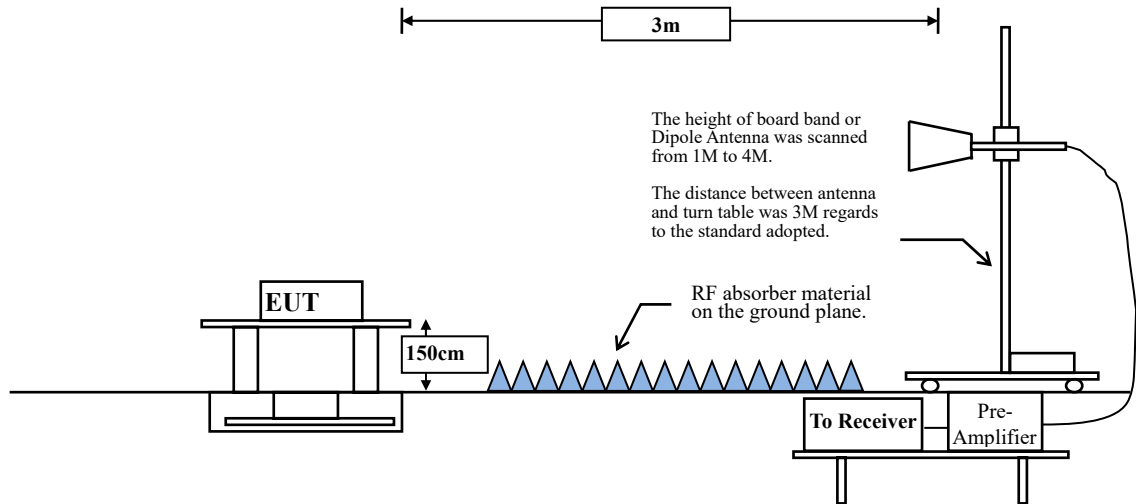

6.2. Limits

Emissions radiated outside of the specified frequency bands, except for harmonics, shall be attenuated by at least 20dB below the level of the fundamental or to the general radiated emission limits in paragraph 15.209, whichever is the lesser attenuation.

6.3. Test Procedure

The EUT was setup according to ANSI C63.10, 2013 and tested according to DTS test procedure of KDB558074 for compliance to FCC 47CFR 15.247 requirements.

The EUT is placed on a turn table which is 1.5 meter above ground. The turn table is rotated 360 degrees to determine the position of the maximum emission level. The EUT was positioned such that the distance from antenna to the EUT was 3 meters.

The antenna is scanned from 1 meter to 4 meters to find out the maximum emission level. This is repeated for both horizontal and vertical polarization of the antenna. In order to find the maximum emission, all of the interface cables were manipulated according to ANSI C63.10:2013 on radiated measurement.

RBW and VBW Parameter setting:

According to KDB 558074 section 12.2.4. Peak power measurement procedure

RBW = as specified in Table 1.

$VBW \geq 3 \times RBW$.

Table 1 —RBW as a function of frequency

Frequency	RBW
9-150 kHz	200-300 Hz
0.15-30 MHz	9-10 kHz
30-1000 MHz	100-120 kHz
> 1000 MHz	1 MHz

According to KDB 558074 section 12.2.5. Average power measurement procedure

RBW = 1MHz.

VBW = 10Hz, when duty cycle $\geq 98 \%$

$VBW \geq 1/T$, when duty cycle $< 98 \%$

(T refers to the minimum transmission duration over which the transmitter is on and is transmitting at its maximum power control level for the tested mode of operation.)

2.4GHz band	Duty Cycle (%)	T (ms)	1/T (Hz)	VBW (Hz)
802.11b	89.46	0.8400	1190	2kHz
802.11g	63.51	0.1768	5656	6kHz
802.11n20	61.60	0.1644	6083	7kHz
802.11n40	49.29	0.1000	10000	10kHz

Note: Duty Cycle Refer to Section 9

6.4. Uncertainty

± 4.08 dB above 1GHz

± 4.22 dB below 1GHz

6.5. Test Result of Band Edge

Product : STREAMING SOUNDBAR
 Test Item : Band Edge Data
 Test Site : No.3 OATS
 Test Date : 2018/10/31
 Test Mode : Mode 1: Transmit (802.11b 1Mbps) (2412MHz)

RF Radiated Measurement (Horizontal):

Channel No.	Frequency (MHz)	Correct Factor (dB)	Reading Level (dBμV)	Emission Level (dBμV/m)	Peak Limit (dBμV/m)	Average Limit (dBμV/m)	Result
01 (Peak)	2375.797	6.412	47.183	53.595	74.00	54.00	Pass
01 (Peak)	2390.000	6.474	44.546	51.021	74.00	54.00	Pass
01 (Peak)	2400.000	6.528	54.881	61.409	--	--	--
01 (Peak)	2410.580	6.593	93.775	100.368	--	--	--
01 (Average)	2376.087	6.413	38.878	45.291	74.00	54.00	Pass
01 (Average)	2390.000	6.474	26.503	32.978	74.00	54.00	Pass
01 (Average)	2400.000	6.528	44.065	50.593	--	--	--
01 (Average)	2411.884	6.602	86.591	93.193	--	--	--

Figure Channel 01: Horizontal (Peak)

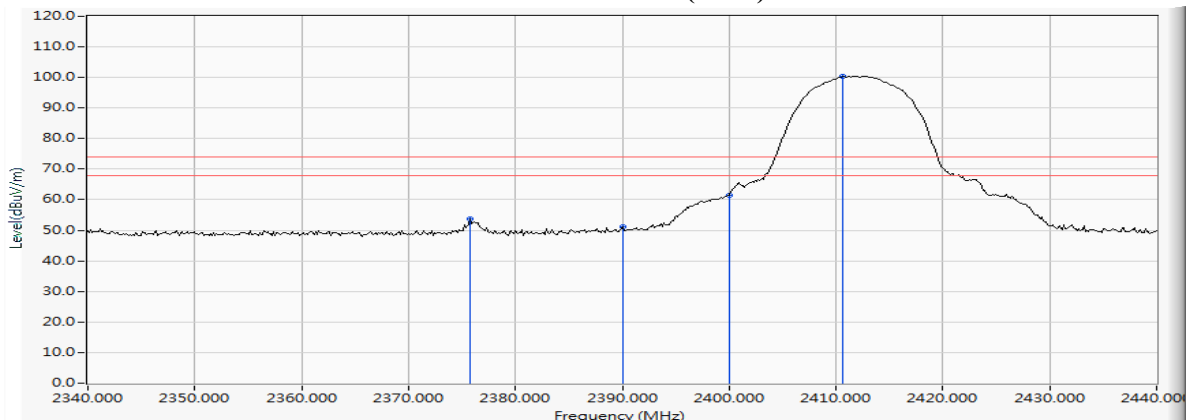
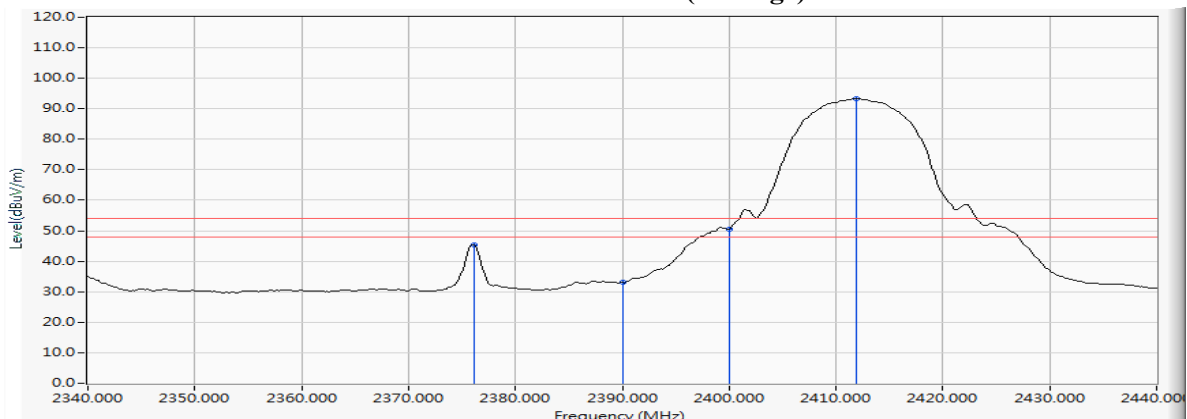

Figure Channel 01: Horizontal (Average)



Note:

1. All readings above 1GHz are performed with peak and/or average measurements as necessary.
2. Measurement Level = Reading Level + Correct Factor.
3. The average measurement was not performed when the peak measured data under the limit of average detection.

Product : STREAMING SOUNDBAR
 Test Item : Band Edge Data
 Test Site : No.3 OATS
 Test Date : 2018/10/31
 Test Mode : Mode 1: Transmit (802.11b 1Mbps) (2412MHz)

RF Radiated Measurement (VERTICAL):

Channel No.	Frequency (MHz)	Correct Factor (dB)	Reading Level (dBμV)	Emission Level (dBμV/m)	Peak Limit (dBμV/m)	Average Limit (dBμV/m)	Result
01 (Peak)	2376.232	5.937	46.663	52.600	74.00	54.00	Pass
01 (Peak)	2390.000	5.880	42.067	47.948	74.00	54.00	Pass
01 (Peak)	2400.000	5.879	55.909	61.788	--	--	--
01 (Peak)	2411.159	5.909	93.870	99.778	--	--	--
01 (Average)	2375.942	5.939	40.633	46.572	74.00	54.00	Pass
01 (Average)	2390.000	5.880	27.889	33.770	74.00	54.00	Pass
01 (Average)	2400.000	5.879	45.487	51.366	--	--	--
01 (Average)	2411.159	5.909	86.932	92.840	--	--	--

Figure Channel 01: VERTICAL (Peak)

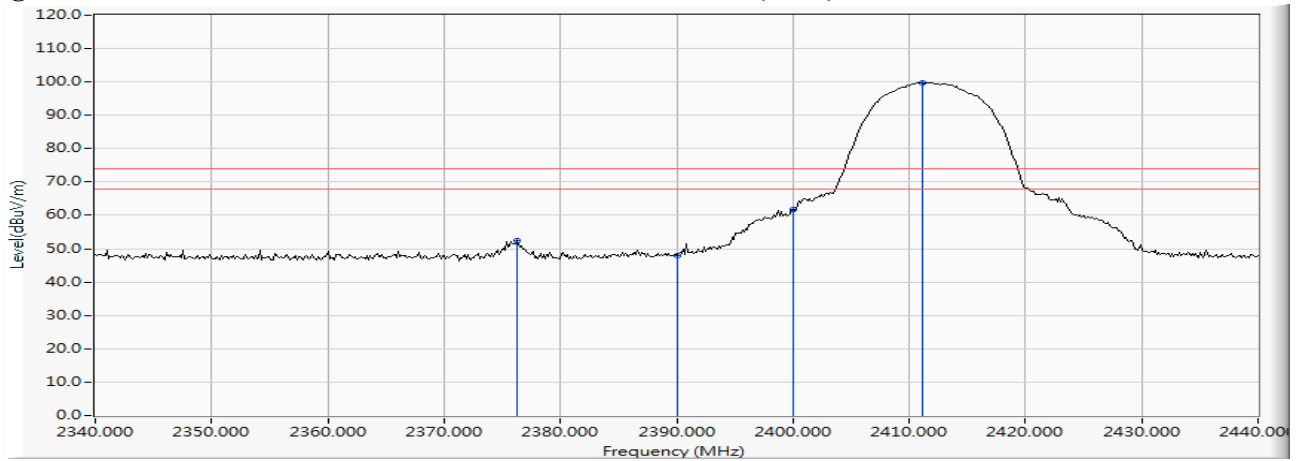
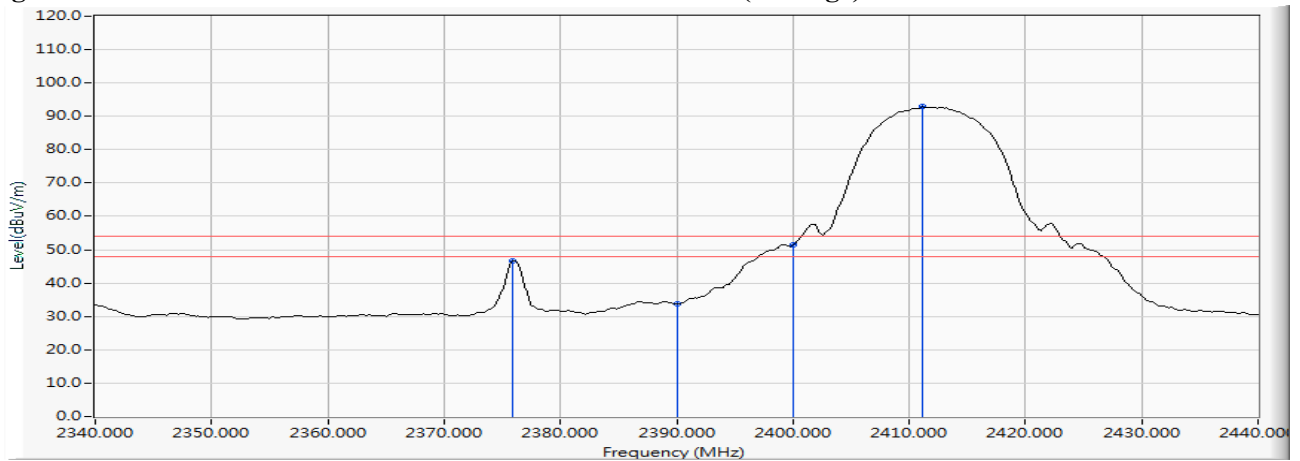

Figure Channel 01: VERTICAL (Average)



Note:

1. All readings above 1GHz are performed with peak and/or average measurements as necessary.
2. Measurement Level = Reading Level + Correct Factor.
3. The average measurement was not performed when the peak measured data under the limit of average detection.

Product : STREAMING SOUNDBAR
 Test Item : Band Edge Data
 Test Site : No.3 OATS
 Test Date : 2018/10/31
 Test Mode : Mode 1: Transmit (802.11b 1Mbps) (2462MHz)

RF Radiated Measurement (Horizontal):

Channel No.	Frequency (MHz)	Correct Factor (dB)	Reading Level (dBμV)	Emission Level (dBμV/m)	Peak Limit (dBμV/m)	Average Limit (dBμV/m)	Result
11 (Peak)	2462.630	6.963	92.493	99.456	--	--	--
11 (Peak)	2483.500	7.110	42.479	49.589	74.00	54.00	Pass
11 (Peak)	2533.065	7.057	48.594	55.651	74.00	54.00	Pass
11 (Average)	2461.761	6.956	85.510	92.467	--	--	--
11 (Average)	2483.500	7.110	26.897	34.007	74.00	54.00	Pass
11 (Average)	2533.500	7.055	38.756	45.811	74.00	54.00	Pass

Figure Channel 11: Horizontal (Peak)

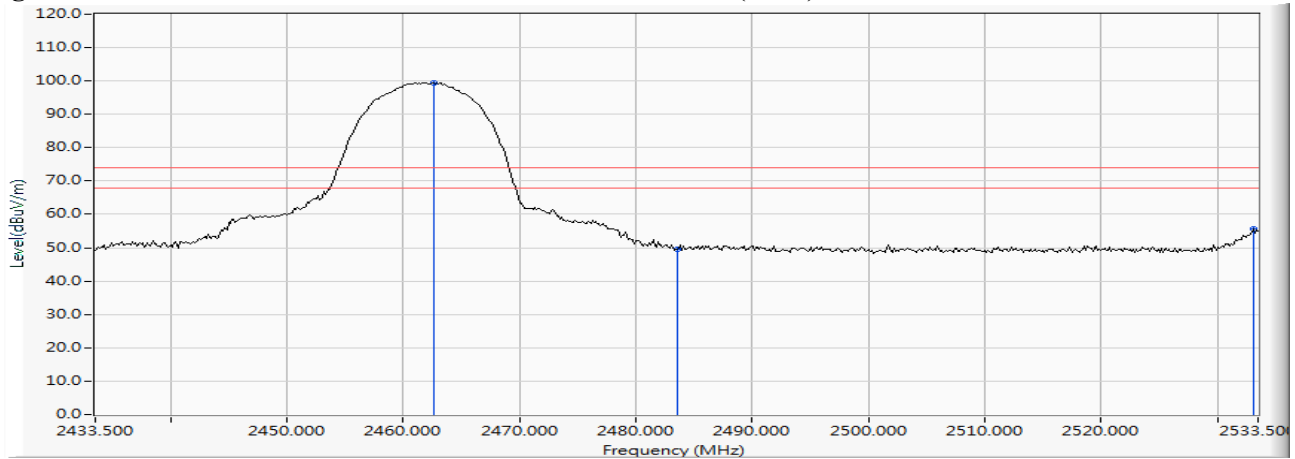
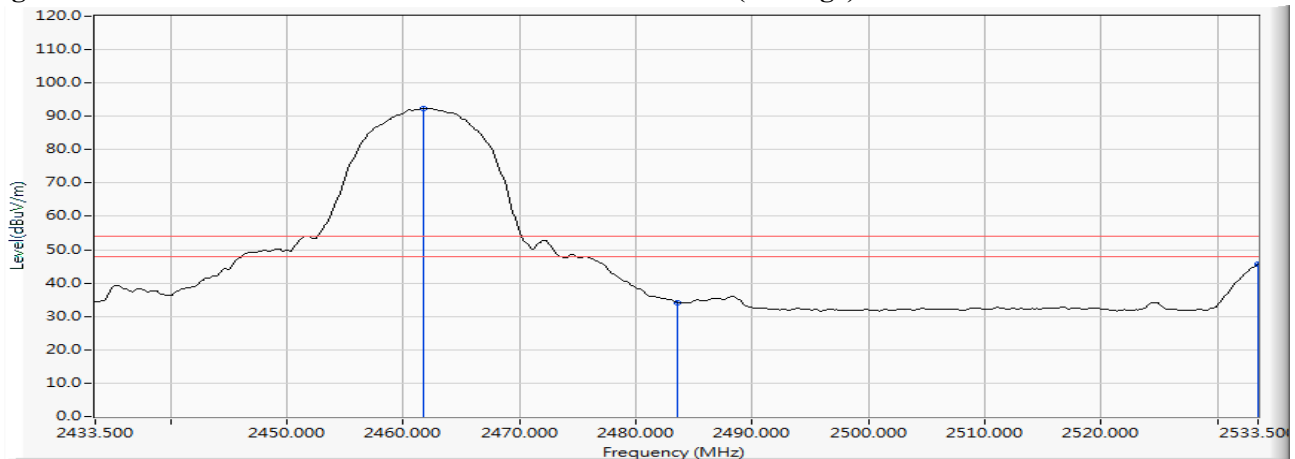

Figure Channel 11: Horizontal (Average)



Note:

1. All readings above 1GHz are performed with peak and/or average measurements as necessary.
2. Measurement Level = Reading Level + Correct Factor.
3. The average measurement was not performed when the peak measured data under the limit of average detection.

Product : STREAMING SOUNDBAR
 Test Item : Band Edge Data
 Test Site : No.3 OATS
 Test Date : 2018/10/31
 Test Mode : Mode 1: Transmit (802.11b 1Mbps) (2462MHz)

RF Radiated Measurement (VERTICAL):

Channel No.	Frequency (MHz)	Correct Factor (dB)	Reading Level (dBμV)	Emission Level (dBμV/m)	Peak Limit (dBμV/m)	Average Limit (dBμV/m)	Result
11 (Peak)	2461.761	6.228	94.923	101.151	--	--	--
11 (Peak)	2483.500	6.363	42.815	49.178	74.00	54.00	Pass
11 (Peak)	2533.210	6.463	45.956	52.419	74.00	54.00	Pass
11 (Average)	2462.630	6.234	88.029	94.262	--	--	--
11 (Average)	2483.500	6.363	27.892	34.255	74.00	54.00	Pass
11 (Average)	2533.500	6.462	34.914	41.376	74.00	54.00	Pass

Figure Channel 11: VERTICAL (Peak)

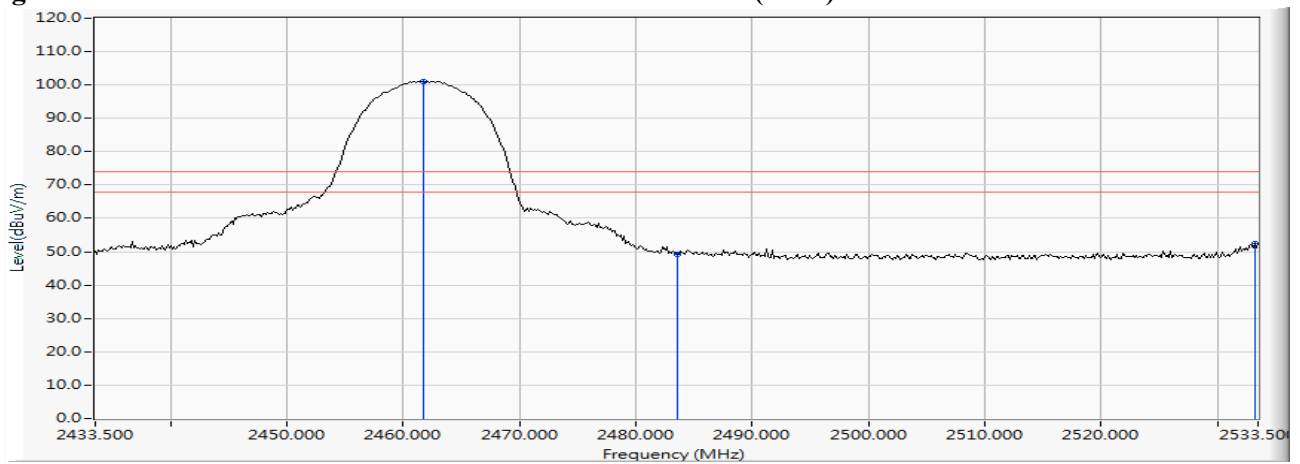
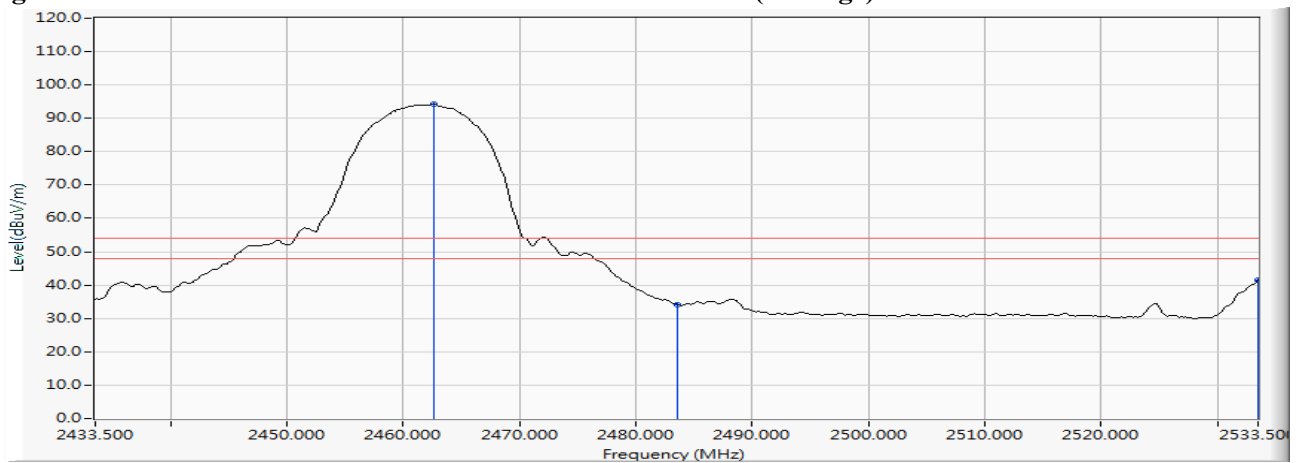

Figure Channel 11: VERTICAL (Average)



Note:

1. All readings above 1GHz are performed with peak and/or average measurements as necessary.
2. Measurement Level = Reading Level + Correct Factor.
3. The average measurement was not performed when the peak measured data under the limit of average detection.

Product : STREAMING SOUNDBAR
 Test Item : Band Edge Data
 Test Site : No.3 OATS
 Test Date : 2018/10/31
 Test Mode : Mode 2: Transmit (802.11g 6Mbps) (2412MHz)

RF Radiated Measurement (Horizontal):

Channel No.	Frequency (MHz)	Correct Factor (dB)	Reading Level (dBμV)	Emission Level (dBμV/m)	Peak Limit (dBμV/m)	Average Limit (dBμV/m)	Result
01 (Peak)	2389.565	6.473	53.459	59.932	74.00	54.00	Pass
01 (Peak)	2390.000	6.474	51.871	58.346	74.00	54.00	Pass
01 (Peak)	2400.000	6.528	63.024	69.552	--	--	--
01 (Peak)	2408.406	6.580	92.329	98.909	--	--	--
01 (Average)	2376.232	6.414	38.522	44.936	74.00	54.00	Pass
01 (Average)	2390.000	6.474	38.520	44.995	74.00	54.00	Pass
01 (Average)	2400.000	6.528	49.910	56.438	--	--	--
01 (Average)	2407.971	6.577	83.800	90.377	--	--	--

Figure Channel 01: Horizontal (Peak)

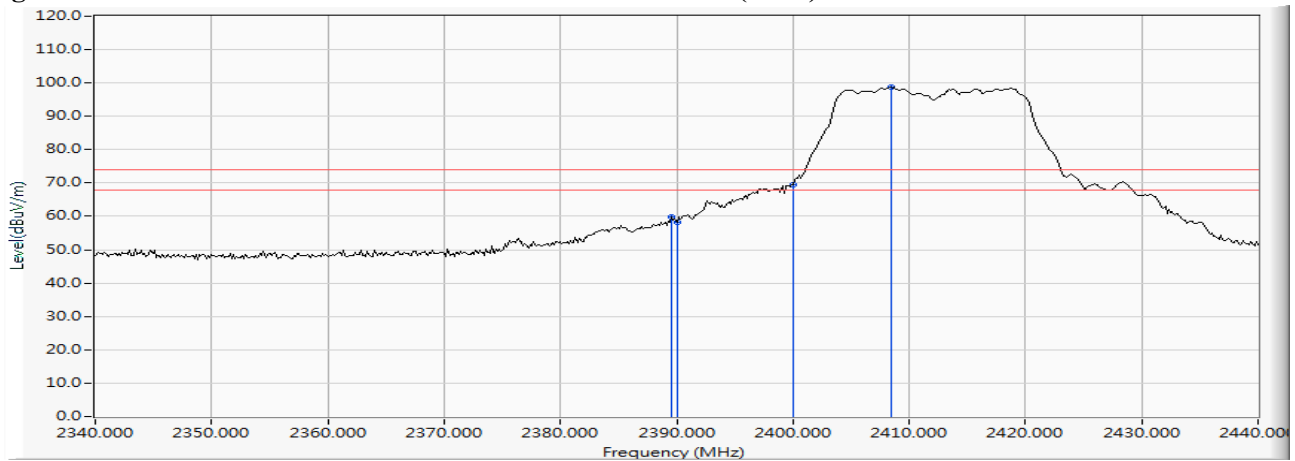
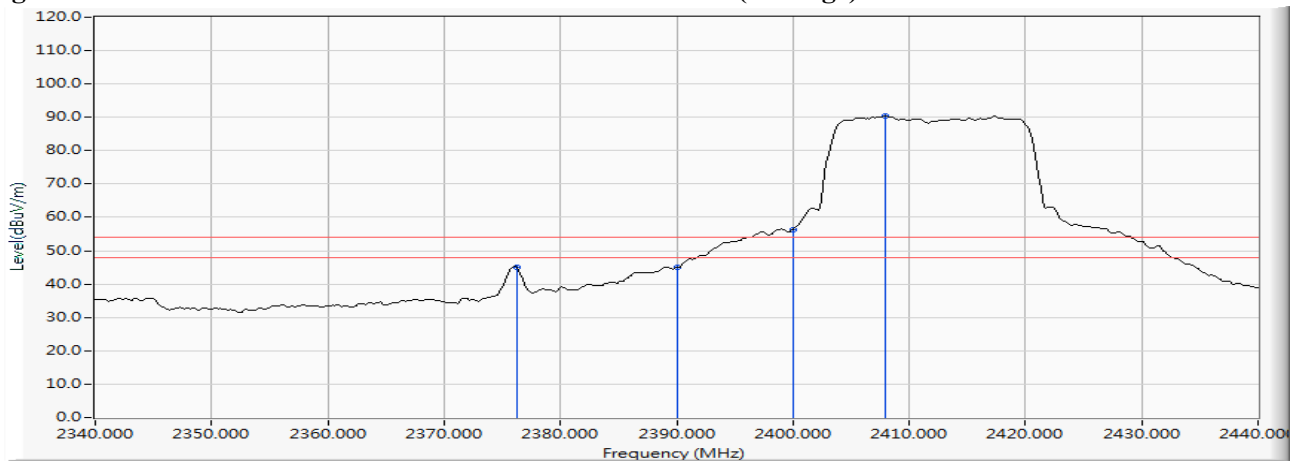

Figure Channel 01: Horizontal (Average)



Note:

1. All readings above 1GHz are performed with peak and/or average measurements as necessary.
2. Measurement Level = Reading Level + Correct Factor.
3. The average measurement was not performed when the peak measured data under the limit of average detection.

Product : STREAMING SOUNDBAR
 Test Item : Band Edge Data
 Test Site : No.3 OATS
 Test Date : 2018/10/31
 Test Mode : Mode 2: Transmit (802.11g 6Mbps) (2412MHz)

RF Radiated Measurement (VERTICAL):

Channel No.	Frequency (MHz)	Correct Factor (dB)	Reading Level (dBμV)	Emission Level (dBμV/m)	Peak Limit (dBμV/m)	Average Limit (dBμV/m)	Result
01 (Peak)	2390.000	5.880	54.931	60.812	74.00	54.00	Pass
01 (Peak)	2400.000	5.879	64.861	70.740	--	--	--
01 (Peak)	2408.406	5.901	92.870	98.771	--	--	--
01 (Average)	2376.087	5.938	40.998	46.936	74.00	54.00	Pass
01 (Average)	2390.000	5.880	40.040	45.921	74.00	54.00	Pass
01 (Average)	2400.000	5.879	50.709	56.588	--	--	--
01 (Average)	2408.406	5.901	84.357	90.258	--	--	--

Figure Channel 01: VERTICAL (Peak)

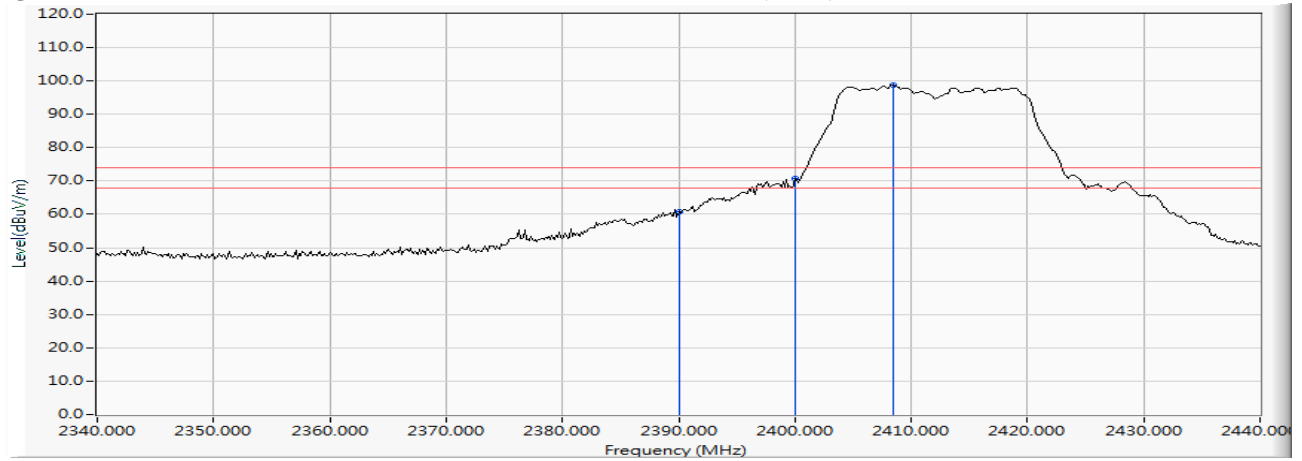
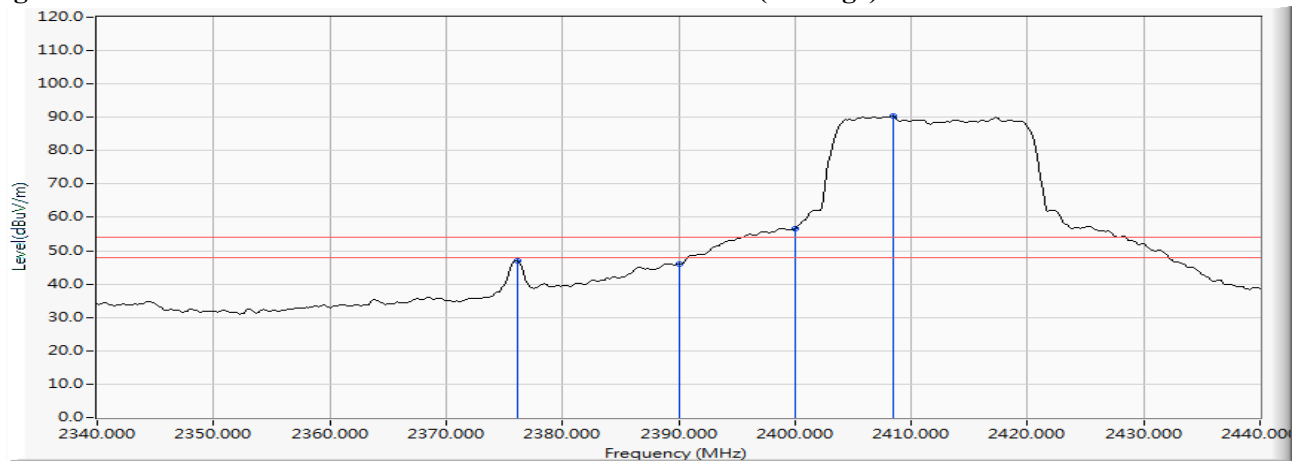

Figure Channel 01: VERTICAL (Average)



Note:

1. All readings above 1GHz are performed with peak and/or average measurements as necessary.
2. Measurement Level = Reading Level + Correct Factor.
3. The average measurement was not performed when the peak measured data under the limit of average detection.

Product : STREAMING SOUNDBAR
 Test Item : Band Edge Data
 Test Site : No.3 OATS
 Test Date : 2018/10/31
 Test Mode : Mode 2: Transmit (802.11g 6Mbps) (2462MHz)

RF Radiated Measurement (Horizontal):

Channel No.	Frequency (MHz)	Correct Factor (dB)	Reading Level (dBμV)	Emission Level (dBμV/m)	Peak Limit (dBμV/m)	Average Limit (dBμV/m)	Result
11 (Peak)	2463.645	6.970	89.955	96.925	--	--	--
11 (Peak)	2483.500	7.110	52.427	59.537	74.00	54.00	Pass
11 (Peak)	2529.442	7.076	48.424	55.500	74.00	54.00	Pass
11 (Average)	2467.268	6.995	81.188	88.183	--	--	--
11 (Average)	2483.500	7.110	36.242	43.352	74.00	54.00	Pass
11 (Average)	2532.775	7.059	37.841	44.900	74.00	54.00	Pass

Figure Channel 11: Horizontal (Peak)

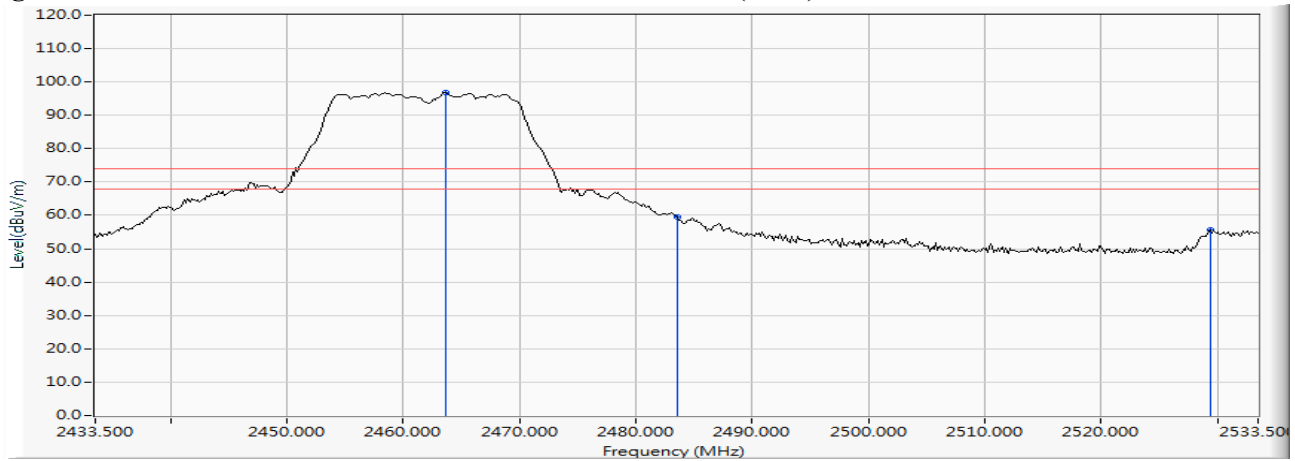
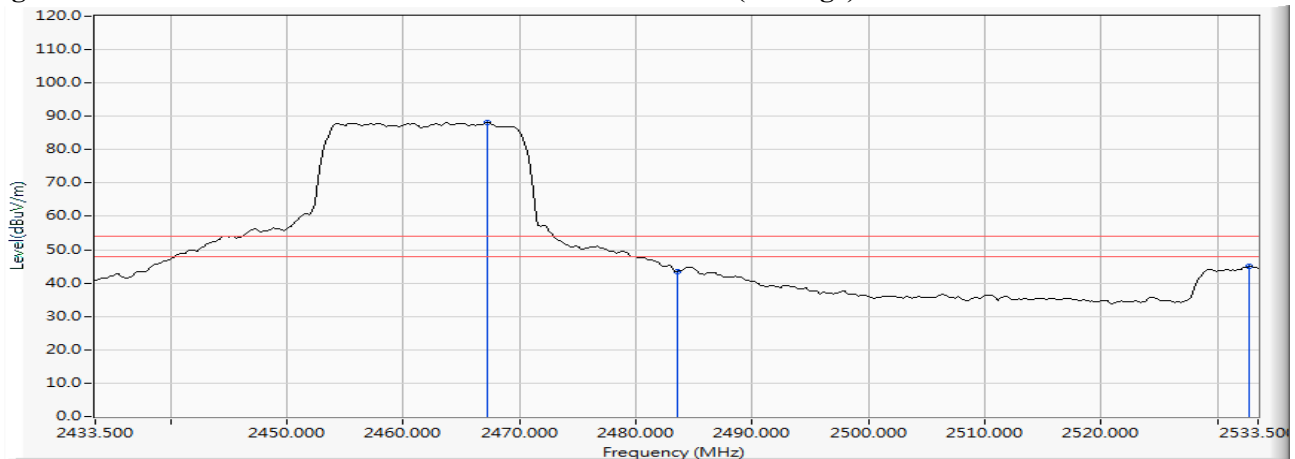

Figure Channel 11: Horizontal (Average)



Note:

1. All readings above 1GHz are performed with peak and/or average measurements as necessary.
2. Measurement Level = Reading Level + Correct Factor.
3. The average measurement was not performed when the peak measured data under the limit of average detection.

Product : STREAMING SOUNDBAR
 Test Item : Band Edge Data
 Test Site : No.3 OATS
 Test Date : 2018/10/31
 Test Mode : Mode 2: Transmit (802.11g 6Mbps) (2462MHz)

RF Radiated Measurement (VERTICAL):

Channel No.	Frequency (MHz)	Correct Factor (dB)	Reading Level (dBμV)	Emission Level (dBμV/m)	Peak Limit (dBμV/m)	Average Limit (dBμV/m)	Result
11 (Peak)	2458.572	6.207	92.271	98.478	--	--	--
11 (Peak)	2483.500	6.363	52.531	58.894	74.00	54.00	Pass
11 (Average)	2464.949	6.248	83.351	89.599	--	--	--
11 (Average)	2483.500	6.363	36.176	42.539	74.00	54.00	Pass

Figure Channel 11: VERTICAL (Peak)

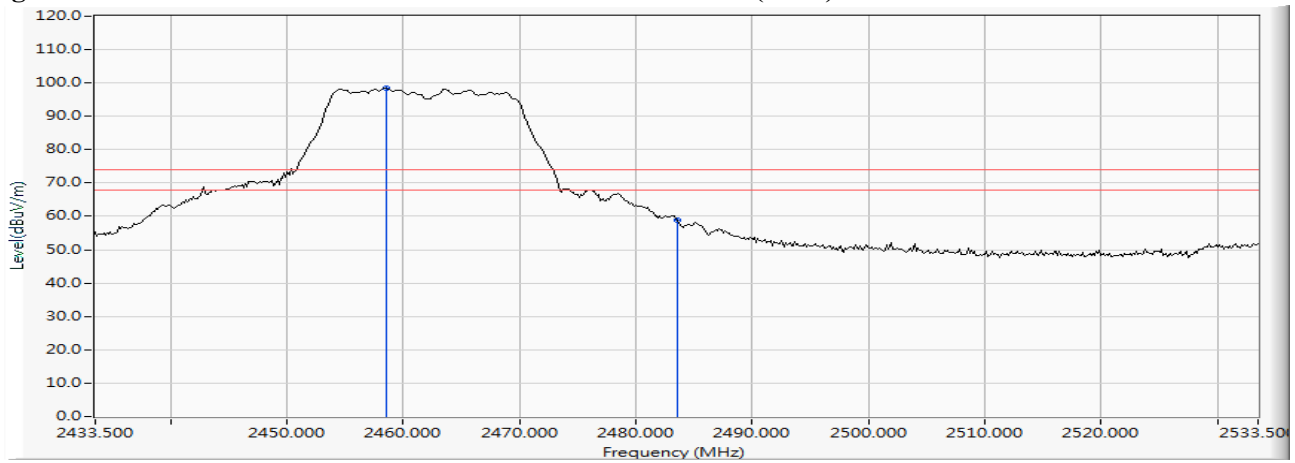
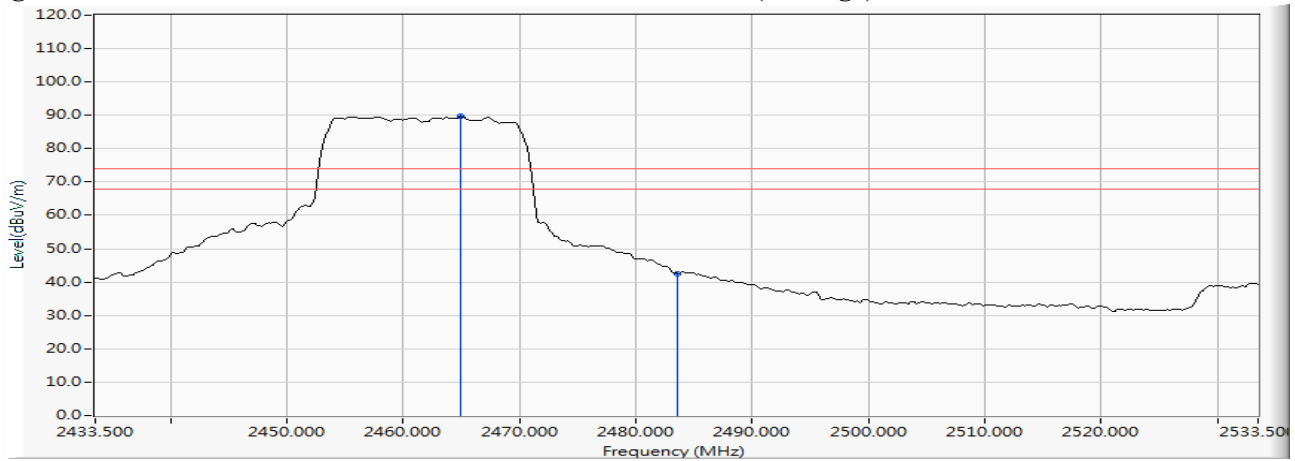

Figure Channel 11: VERTICAL (Average)



Note:

1. All readings above 1GHz are performed with peak and/or average measurements as necessary.
2. Measurement Level = Reading Level + Correct Factor.
3. The average measurement was not performed when the peak measured data under the limit of average detection.

Product : STREAMING SOUNDBAR
 Test Item : Band Edge Data
 Test Site : No.3 OATS
 Test Date : 2018/10/31
 Test Mode : Mode 3: Transmit (802.11n MCS0 7.2Mbps 20M-BW) (2412MHz)

RF Radiated Measurement (Horizontal):

Channel No.	Frequency (MHz)	Correct Factor (dB)	Reading Level (dBμV)	Emission Level (dBμV/m)	Peak Limit (dBμV/m)	Average Limit (dBμV/m)	Result
01 (Peak)	2390.000	6.474	53.505	59.980	74.00	54.00	Pass
01 (Peak)	2398.551	6.520	62.278	68.798	74.00	54.00	Pass
01 (Peak)	2400.000	6.528	60.172	66.700	--	--	--
01 (Peak)	2417.101	6.639	90.973	97.612	--	--	--
01 (Average)	2376.087	6.413	39.056	45.469	74.00	54.00	Pass
01 (Average)	2390.000	6.474	33.732	40.207	74.00	54.00	Pass
01 (Average)	2400.000	6.528	46.172	52.700	--	--	--
01 (Average)	2417.536	6.642	81.551	88.193	--	--	--

Figure Channel 01: Horizontal (Peak)

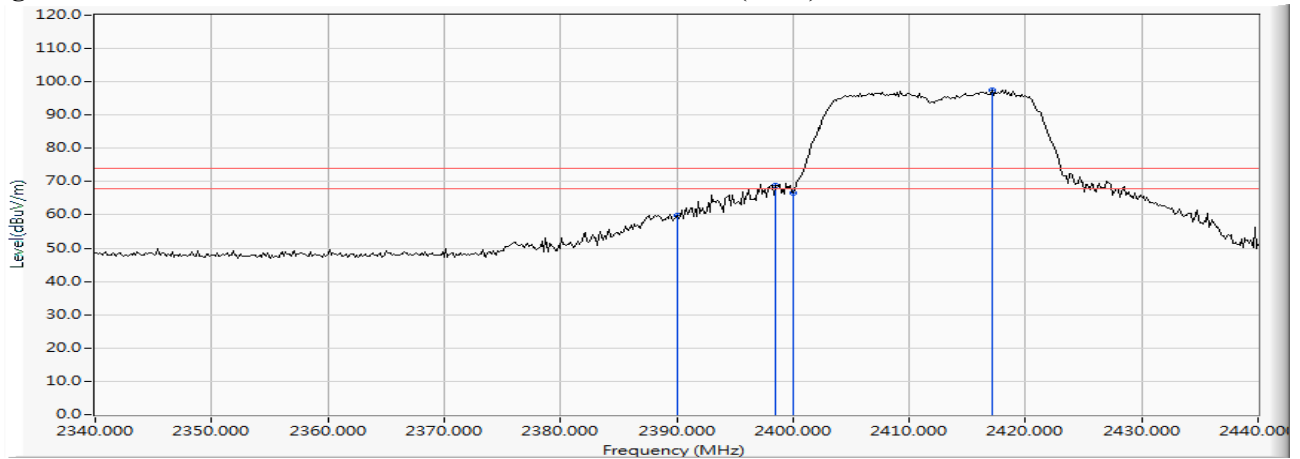
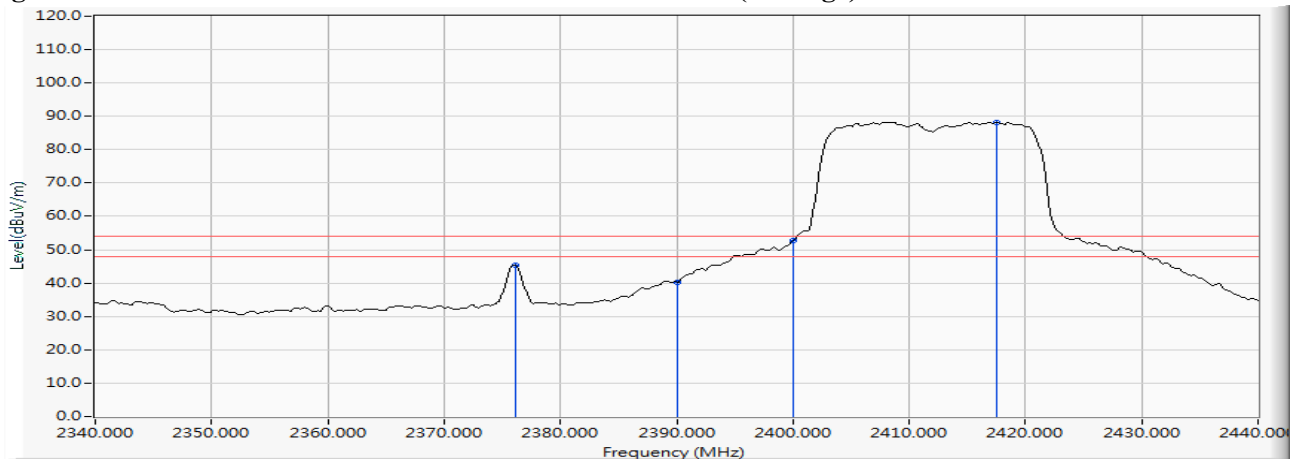

Figure Channel 01: Horizontal (Average)



Note:

1. All readings above 1GHz are performed with peak and/or average measurements as necessary.
2. Measurement Level = Reading Level + Correct Factor.
3. The average measurement was not performed when the peak measured data under the limit of average detection.

Product : STREAMING SOUNDBAR
 Test Item : Band Edge Data
 Test Site : No.3 OATS
 Test Date : 2018/10/31
 Test Mode : Mode 3: Transmit (802.11n MCS0 7.2Mbps 20M-BW) (2412MHz)

RF Radiated Measurement (VERTICAL):

Channel No.	Frequency (MHz)	Correct Factor (dB)	Reading Level (dBμV)	Emission Level (dBμV/m)	Peak Limit (dBμV/m)	Average Limit (dBμV/m)	Result
01 (Peak)	2389.565	5.882	57.414	63.296	74.00	54.00	Pass
01 (Peak)	2390.000	5.880	56.296	62.177	74.00	54.00	Pass
01 (Peak)	2400.000	5.879	65.654	71.533	--	--	--
01 (Peak)	2409.130	5.902	91.272	97.175	--	--	--
01 (Average)	2375.942	5.939	40.253	46.192	74.00	54.00	Pass
01 (Average)	2390.000	5.880	35.691	41.572	74.00	54.00	Pass
01 (Average)	2400.000	5.879	46.964	52.843	--	--	--
01 (Average)	2405.507	5.893	81.986	87.879	--	--	--

Figure Channel 01: VERTICAL (Peak)

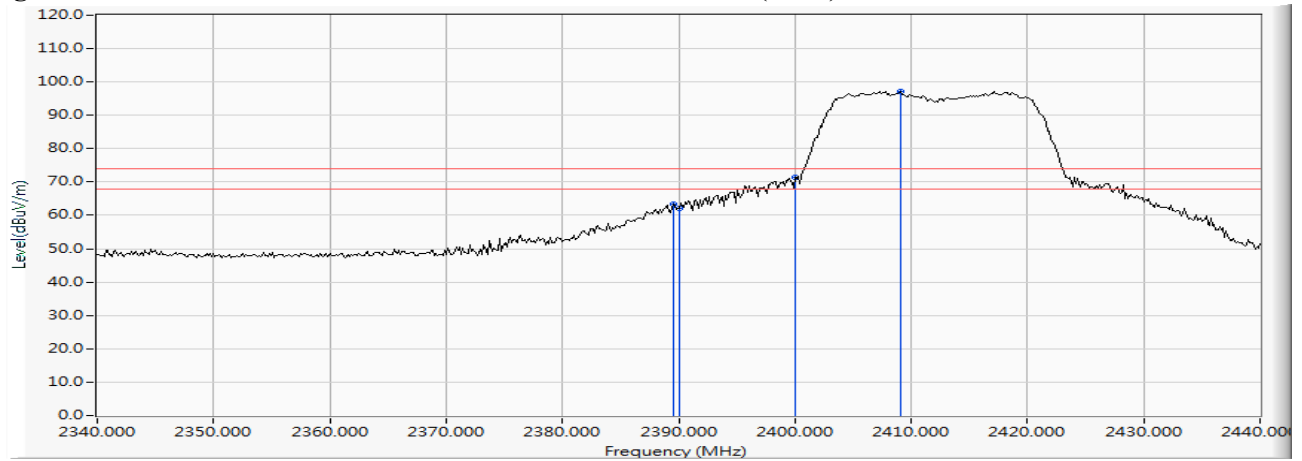
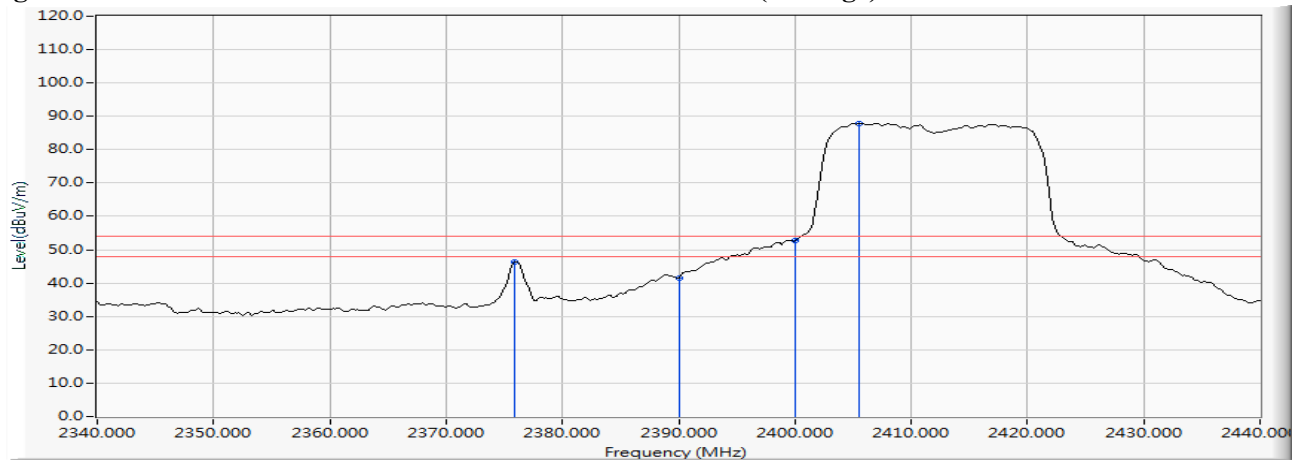

Figure Channel 01: VERTICAL (Average)



Note:

1. All readings above 1GHz are performed with peak and/or average measurements as necessary.
2. Measurement Level = Reading Level + Correct Factor.
3. The average measurement was not performed when the peak measured data under the limit of average detection.

Product : STREAMING SOUNDBAR
 Test Item : Band Edge Data
 Test Site : No.3 OATS
 Test Date : 2018/10/31
 Test Mode : Mode 3: Transmit (802.11n MCS0 7.2Mbps 20M-BW) (2462MHz)

RF Radiated Measurement (Horizontal):

Channel No.	Frequency (MHz)	Correct Factor (dB)	Reading Level (dBμV)	Emission Level (dBμV/m)	Peak Limit (dBμV/m)	Average Limit (dBμV/m)	Result
11 (Peak)	2467.123	6.994	89.155	96.149	--	--	--
11 (Peak)	2483.500	7.110	53.638	60.748	74.00	54.00	Pass
11 (Average)	2466.688	6.991	79.882	86.873	--	--	--
11 (Average)	2483.500	7.110	31.431	38.541	74.00	54.00	Pass
11 (Average)	2532.630	7.060	36.449	43.508	74.00	54.00	Pass

Figure Channel 11: Horizontal (Peak)

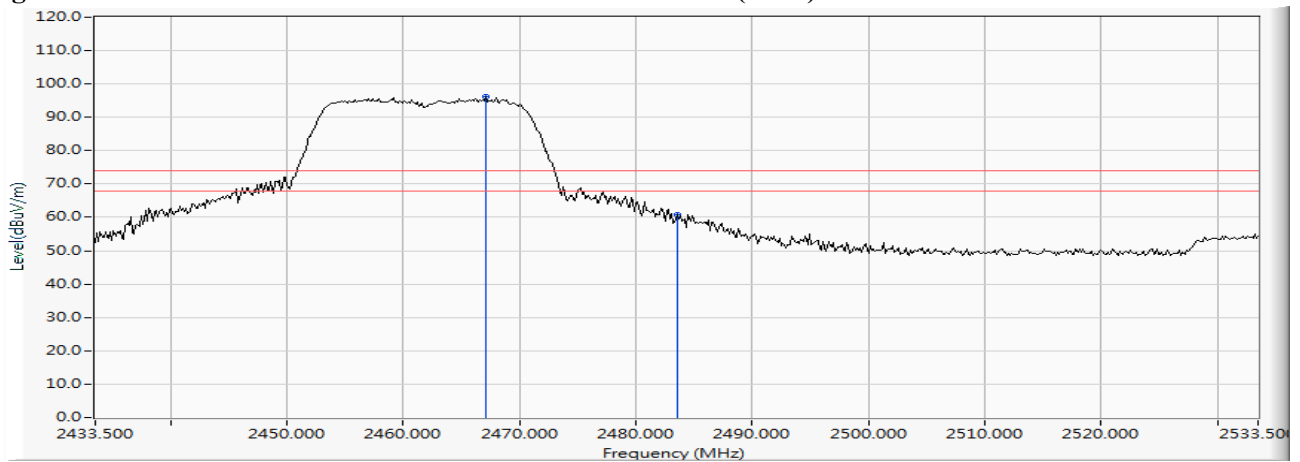
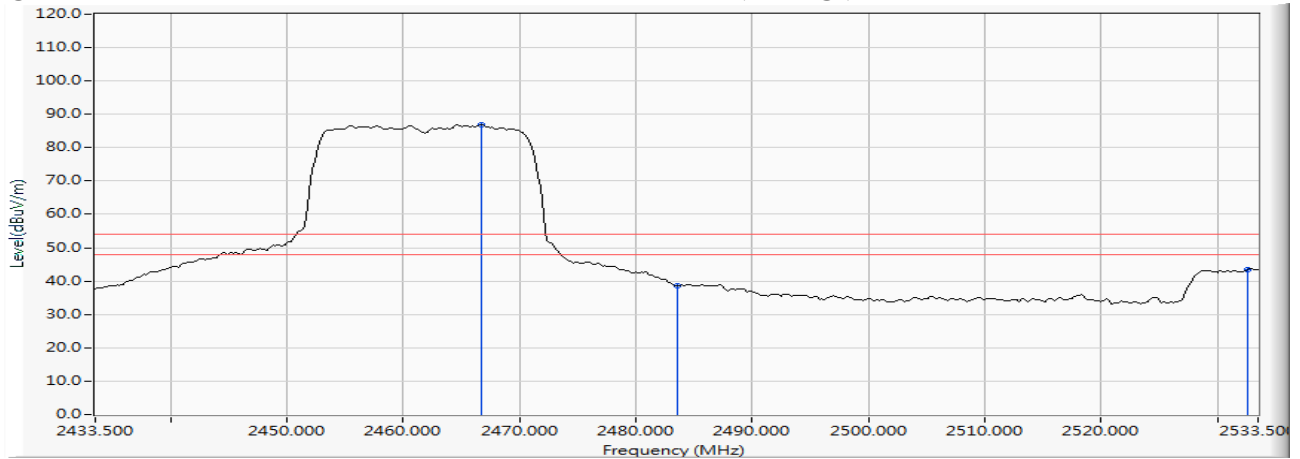

Figure Channel 11: Horizontal (Average)



Note:

1. All readings above 1GHz are performed with peak and/or average measurements as necessary.
2. Measurement Level = Reading Level + Correct Factor.
3. The average measurement was not performed when the peak measured data under the limit of average detection.

Product : STREAMING SOUNDBAR
 Test Item : Band Edge Data
 Test Site : No.3 OATS
 Test Date : 2018/10/31
 Test Mode : Mode 3: Transmit (802.11n MCS0 7.2Mbps 20M-BW) (2462MHz)

RF Radiated Measurement (VERTICAL):

Channel No.	Frequency (MHz)	Correct Factor (dB)	Reading Level (dBμV)	Emission Level (dBμV/m)	Peak Limit (dBμV/m)	Average Limit (dBμV/m)	Result
11 (Peak)	2459.152	6.211	91.513	97.724	--	--	--
11 (Peak)	2483.500	6.363	53.623	59.986	74.00	54.00	Pass
11 (Average)	2457.558	6.201	82.094	88.295	--	--	--
11 (Average)	2483.500	6.363	31.500	37.863	74.00	54.00	Pass
11 (Average)	2532.486	6.463	33.300	39.763	74.00	54.00	Pass

Figure Channel 11: VERTICAL (Peak)

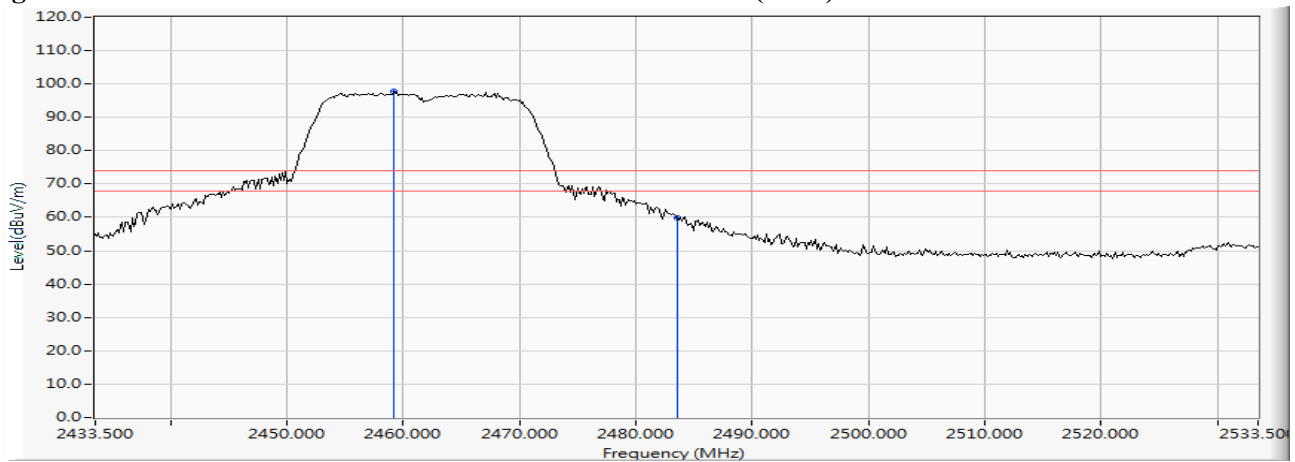
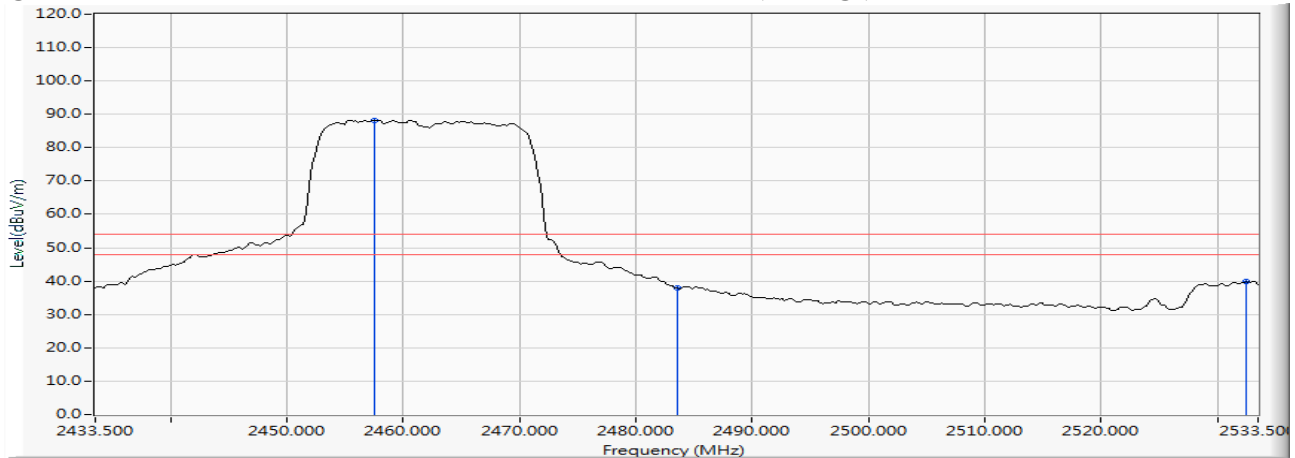

Figure Channel 11: VERTICAL (Average)



Note:

1. All readings above 1GHz are performed with peak and/or average measurements as necessary.
2. Measurement Level = Reading Level + Correct Factor.
3. The average measurement was not performed when the peak measured data under the limit of average detection.

Product : STREAMING SOUNDBAR
 Test Item : Band Edge Data
 Test Site : No.3 OATS
 Test Date : 2018/12/05
 Test Mode : Mode 4: Transmit (802.11n MCS0 15Mbps 40M-BW) (2422MHz)

RF Radiated Measurement (Horizontal):

Channel No.	Frequency (MHz)	Correct Factor (dB)	Reading Level (dBμV)	Emission Level (dBμV/m)	Peak Limit (dBμV/m)	Average Limit (dBμV/m)	Result
03 (Peak)	2390.000	6.474	57.654	64.129	74.00	54.00	Pass
03 (Peak)	2400.000	6.528	63.347	69.875	74.00	54.00	Pass
03 (Peak)	2417.971	6.646	92.473	99.118	--	--	--
03 (Average)	2388.841	6.470	35.647	42.117	74.00	54.00	Pass
03 (Average)	2390.000	6.474	33.734	40.209	74.00	54.00	Pass
03 (Average)	2400.000	6.528	41.918	48.446	--	--	--
03 (Average)	2418.261	6.647	82.961	89.608	--	--	--

Figure Channel 03: Horizontal (Peak)

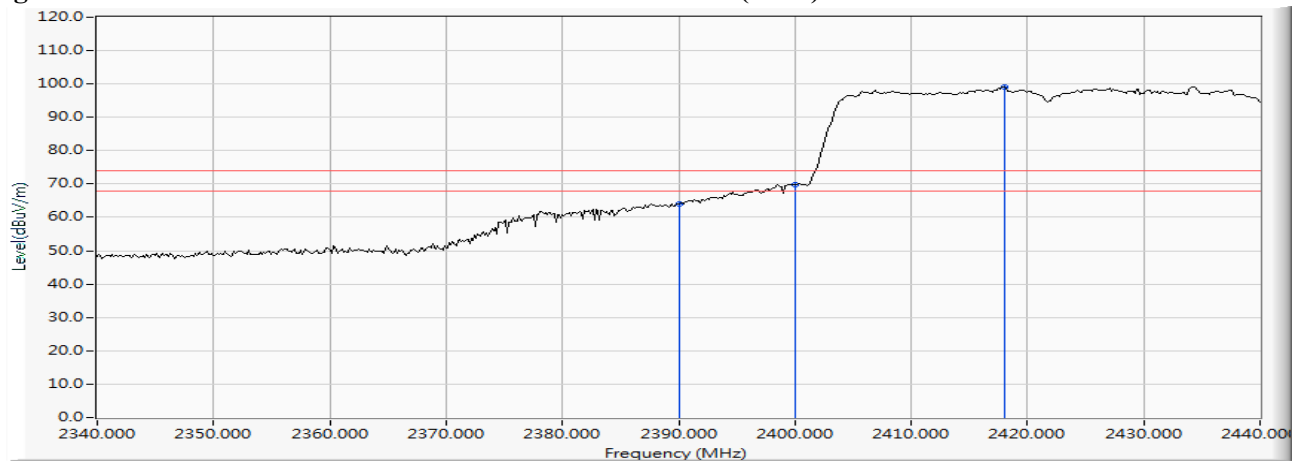
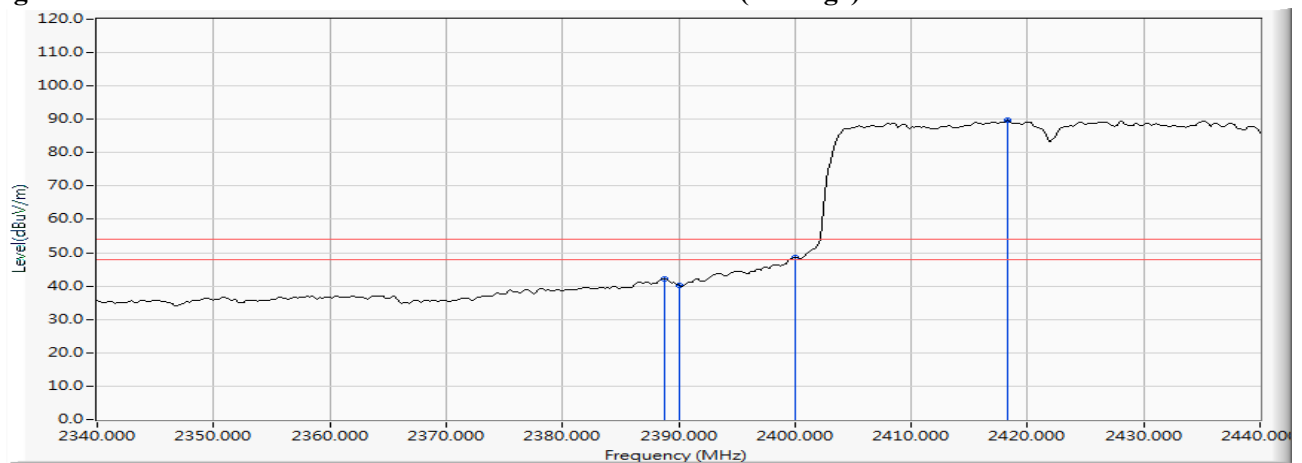

Figure Channel 03: Horizontal (Average)



Note:

1. All readings above 1GHz are performed with peak and/or average measurements as necessary.
2. Measurement Level = Reading Level + Correct Factor.
3. The average measurement was not performed when the peak measured data under the limit of average detection.

Product : STREAMING SOUNDBAR
 Test Item : Band Edge Data
 Test Site : No.3 OATS
 Test Date : 2018/12/05
 Test Mode : Mode 4: Transmit (802.11n MCS0 15Mbps 40M-BW) (2422MHz)

RF Radiated Measurement (VERTICAL):

Channel No.	Frequency (MHz)	Correct Factor (dB)	Reading Level (dBμV)	Emission Level (dBμV/m)	Peak Limit (dBμV/m)	Average Limit (dBμV/m)	Result
03 (Peak)	2387.826	5.889	56.372	62.262	74.00	54.00	Pass
03 (Peak)	2390.000	5.880	55.449	61.330	74.00	54.00	Pass
03 (Peak)	2400.000	5.879	61.027	66.906	--	--	--
03 (Peak)	2434.348	6.054	88.796	94.850	--	--	--
03 (Average)	2385.507	5.900	35.875	41.774	74.00	54.00	Pass
03 (Average)	2390.000	5.880	33.933	39.814	74.00	54.00	Pass
03 (Average)	2400.000	5.879	38.550	44.429	--	--	--
03 (Average)	2407.681	5.898	78.525	84.424	--	--	--

Figure Channel 03: VERTICAL (Peak)

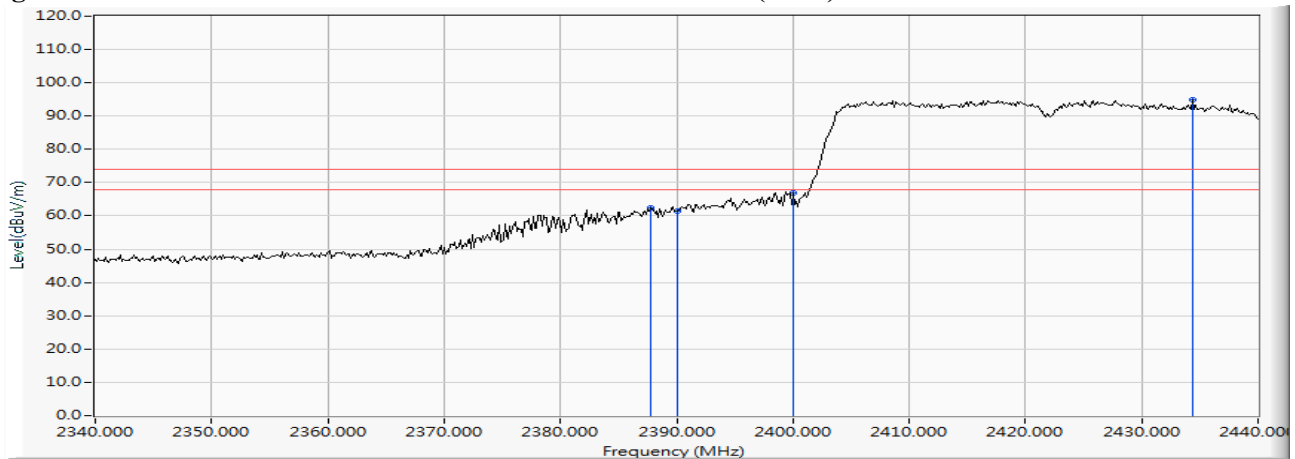
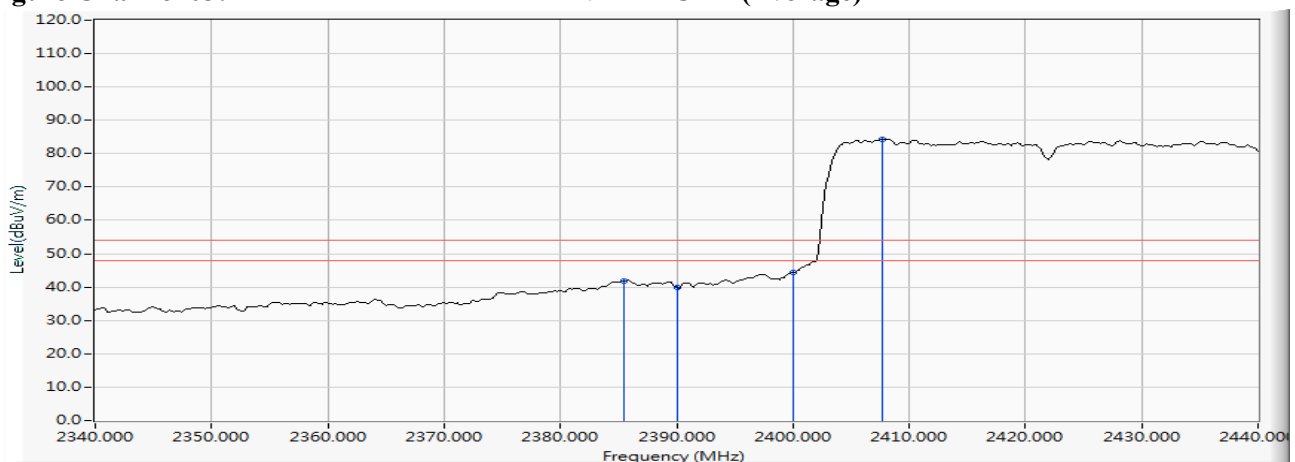

Figure Channel 03: VERTICAL (Average)



Note:

1. All readings above 1GHz are performed with peak and/or average measurements as necessary.
2. Measurement Level = Reading Level + Correct Factor.
3. The average measurement was not performed when the peak measured data under the limit of average detection.

Product : STREAMING SOUNDBAR
 Test Item : Band Edge Data
 Test Site : No.3 OATS
 Test Date : 2018/12/05
 Test Mode : Mode 4: Transmit (802.11n MCS0 15Mbps 40M-BW) (2452MHz)

RF Radiated Measurement (Horizontal):

Channel No.	Frequency (MHz)	Correct Factor (dB)	Reading Level (dBμV)	Emission Level (dBμV/m)	Peak Limit (dBμV/m)	Average Limit (dBμV/m)	Result
09 (Peak)	2464.225	6.974	94.158	101.132	--	--	--
09 (Peak)	2483.500	7.110	60.175	67.285	74.00	54.00	Pass
09 (Average)	2465.094	6.980	84.068	91.048	--	--	--
09 (Average)	2483.500	7.110	38.580	45.690	74.00	54.00	Pass
09 (Average)	2489.152	7.150	42.111	49.261	74.00	54.00	Pass

Figure Channel 09: Horizontal (Peak)

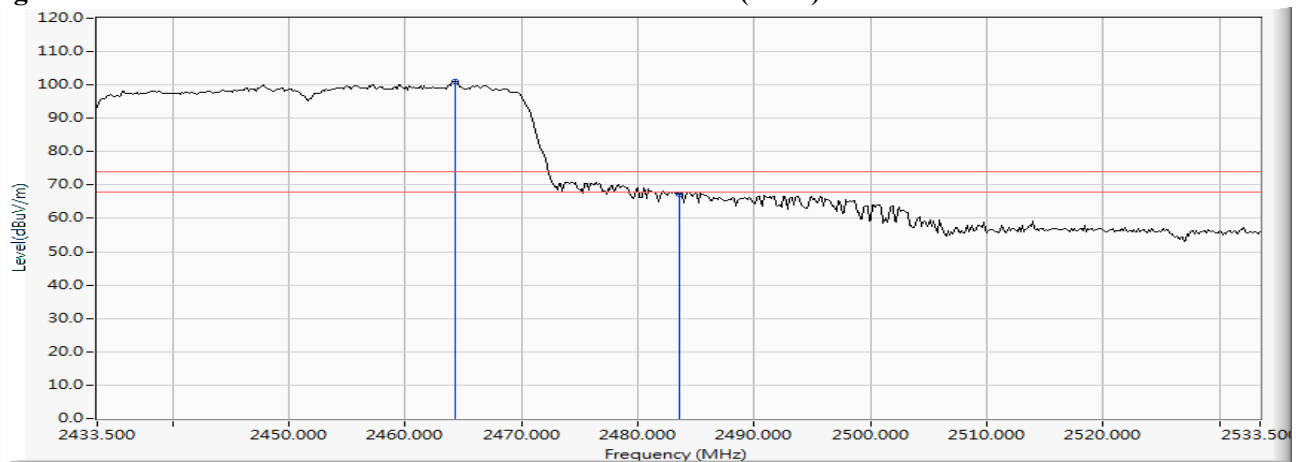
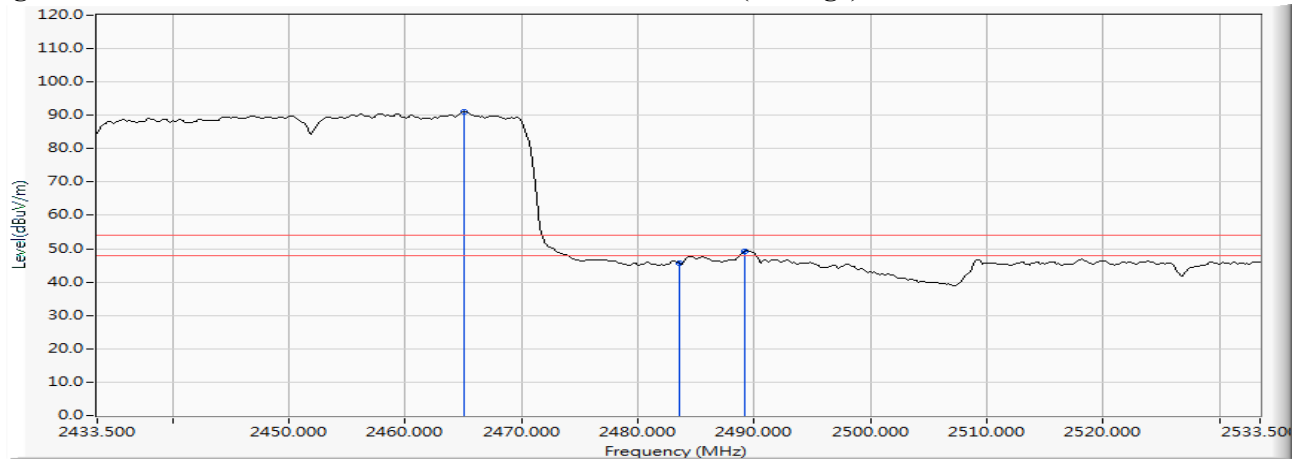

Figure Channel 09: Horizontal (Average)



Note:

1. All readings above 1GHz are performed with peak and/or average measurements as necessary.
2. Measurement Level = Reading Level + Correct Factor.
3. The average measurement was not performed when the peak measured data under the limit of average detection.

Product : STREAMING SOUNDBAR
 Test Item : Band Edge Data
 Test Site : No.3 OATS
 Test Date : 2018/12/05
 Test Mode : Mode 4: Transmit (802.11n MCS0 15Mbps 40M-BW) (2452MHz)

RF Radiated Measurement (VERTICAL):

Channel No.	Frequency (MHz)	Correct Factor (dB)	Reading Level (dBμV)	Emission Level (dBμV/m)	Peak Limit (dBμV/m)	Average Limit (dBμV/m)	Result
09 (Peak)	2464.514	6.245	91.891	98.136	--	--	--
09 (Peak)	2483.500	6.363	56.851	63.214	74.00	54.00	Pass
09 (Peak)	2484.080	6.367	59.828	66.195	74.00	54.00	Pass
09 (Average)	2459.297	6.212	81.725	87.937	--	--	--
09 (Average)	2483.500	6.363	33.834	40.197	74.00	54.00	Pass
09 (Average)	2532.920	6.463	40.538	47.001	74.00	54.00	Pass

Figure Channel 09: VERTICAL (Peak)

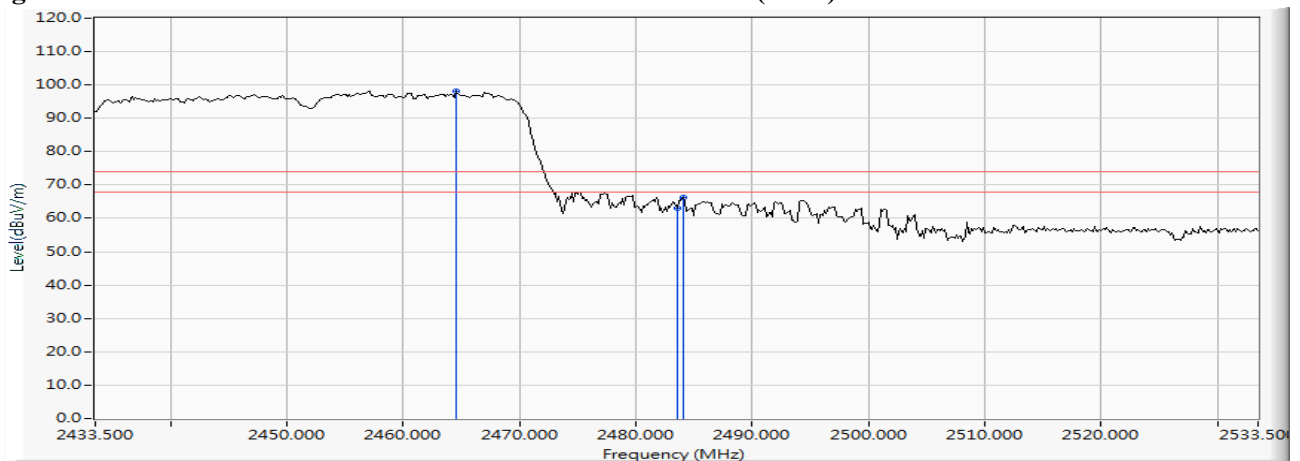
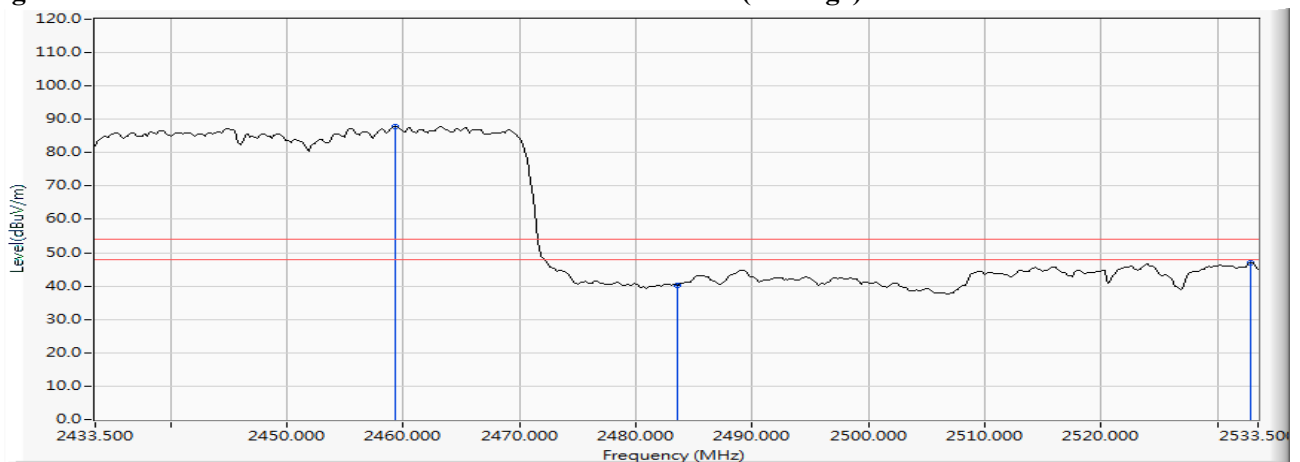

Figure Channel 09: VERTICAL (Average)



Note:

1. All readings above 1GHz are performed with peak and/or average measurements as necessary.
2. Measurement Level = Reading Level + Correct Factor.
3. The average measurement was not performed when the peak measured data under the limit of average detection.

7. 6dB Bandwidth

7.1. Test Setup

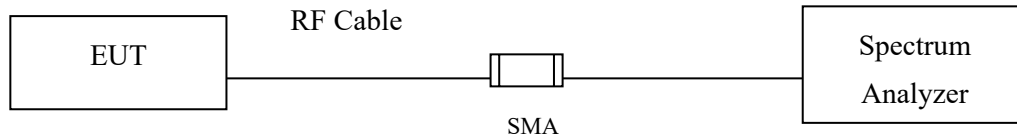

7.2. Limits

The minimum bandwidth shall be at least 500 kHz.

7.3. Test Procedure

The EUT was setup according to ANSI C63.4: 2014; tested according to DTS test procedure of Jan KDB558074 for compliance to FCC 47CFR 15.247 requirements.

7.4. Uncertainty

$\pm 283\text{Hz}$

7.5. Test Result of 6dB Bandwidth

Product : STREAMING SOUNDBAR
 Test Item : 6dB Bandwidth Data
 Test Site : No.3 OATS
 Test Mode : Mode 1: Transmit (802.11b 1Mbps)

Channel No.	Frequency (MHz)	Measurement Level (kHz)	Required Limit (kHz)	Result
01	2412	7600	>500	Pass
06	2437	7600	>500	Pass
11	2462	8150	>500	Pass

Figure Channel 01:

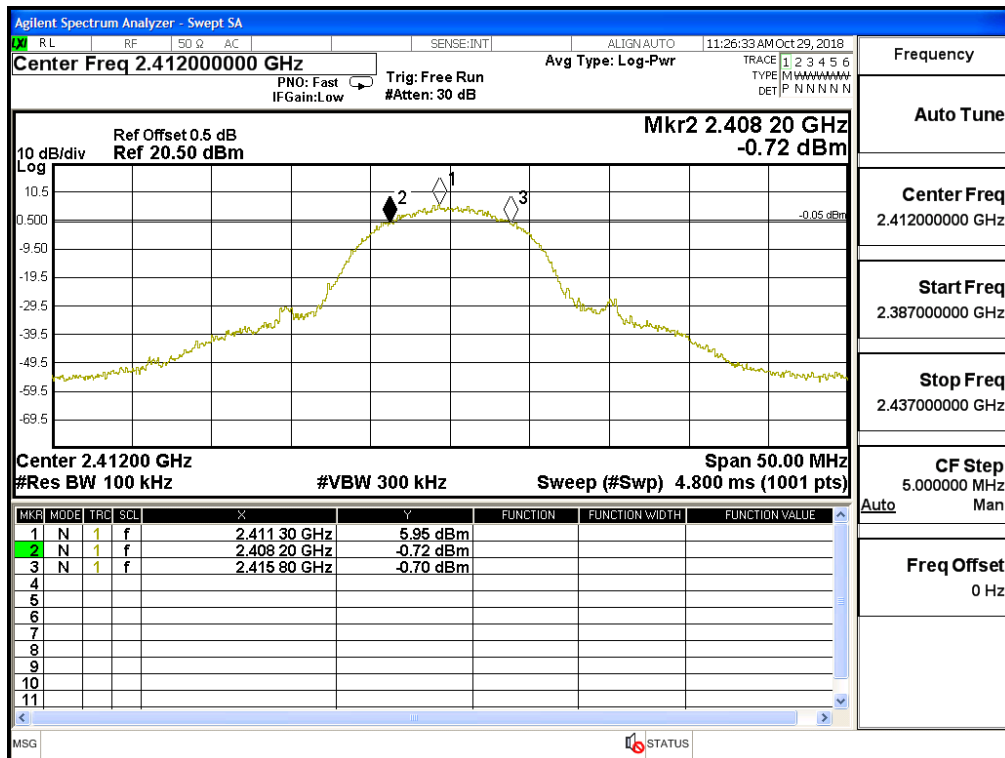

Product : STREAMING SOUNDBAR
 Test Item : 6dB Bandwidth Data
 Test Site : No.3 OATS
 Test Mode : Mode 2: Transmit (802.11g 6Mbps) (2412MHz)

Channel No.	Frequency (MHz)	Measurement Level (kHz)	Required Limit (kHz)	Result
01	2412	16500	>500	Pass
06	2437	16450	>500	Pass
11	2462	16450	>500	Pass

Figure Channel 01:

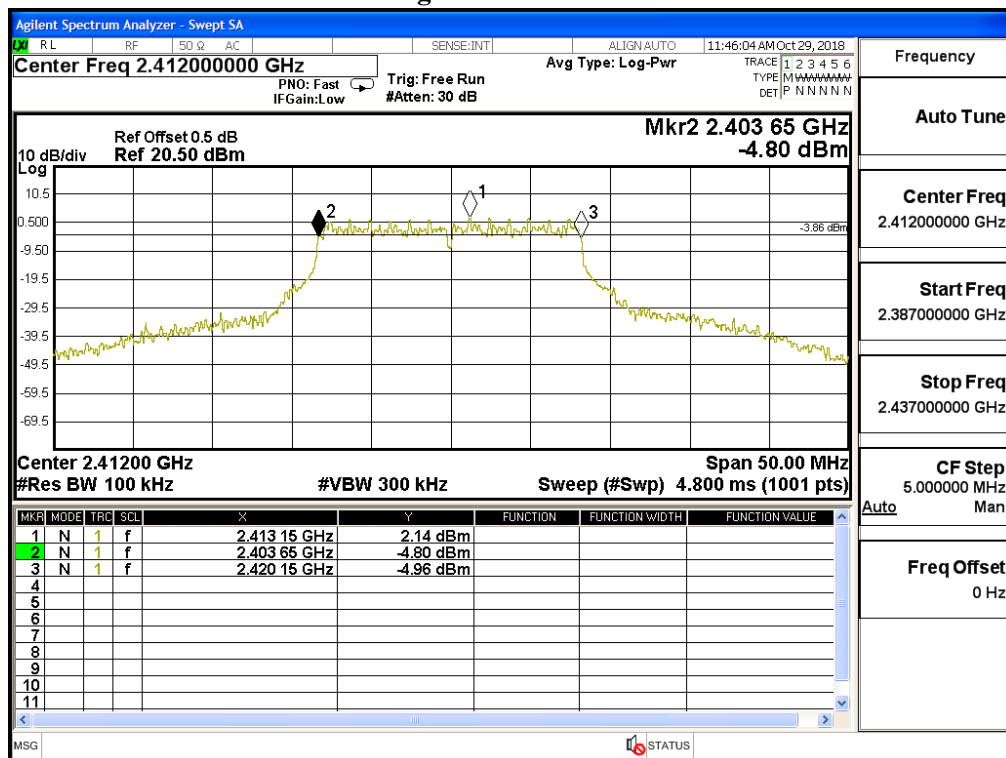

Figure Channel 06:

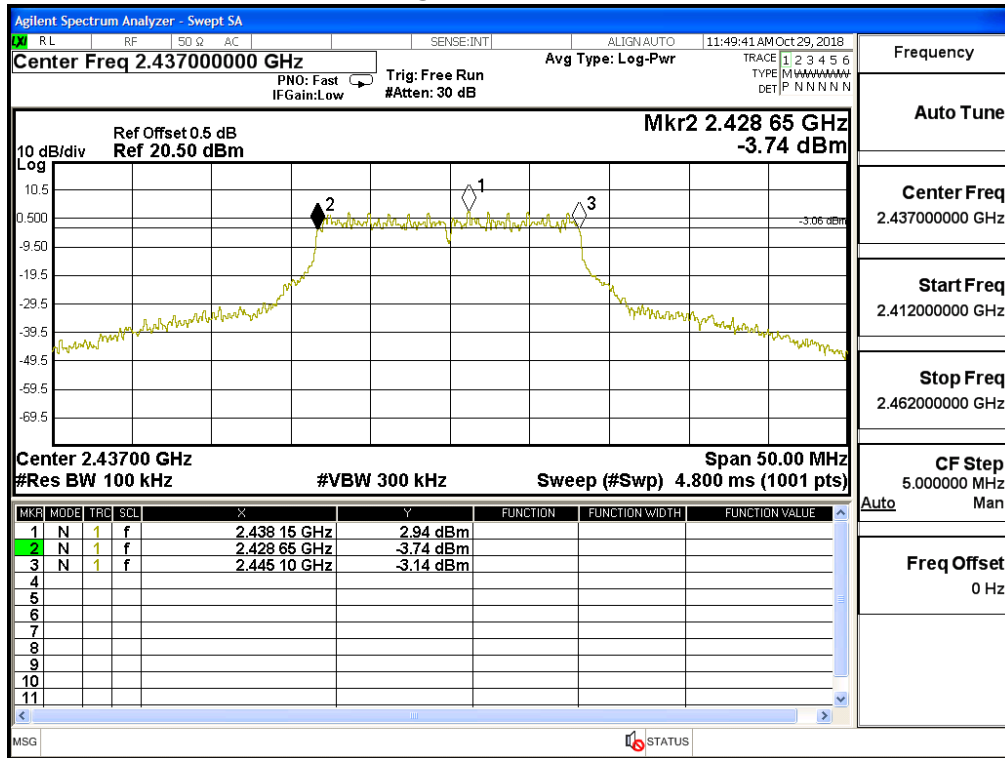

Figure Channel 11:

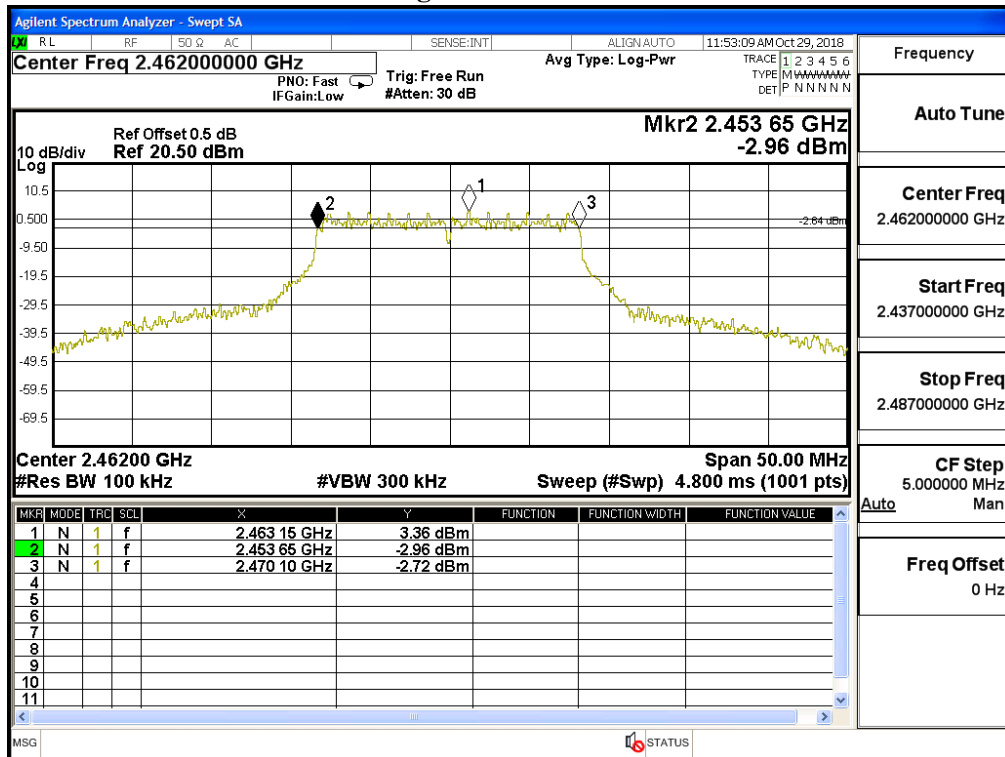

Figure Channel 06:

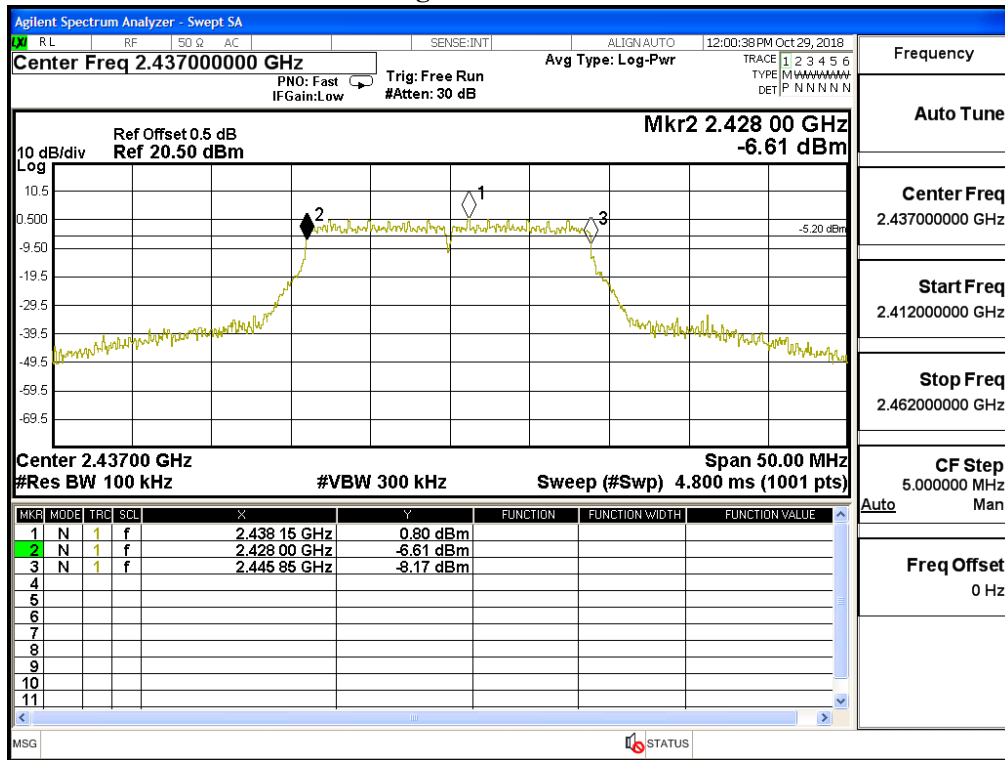
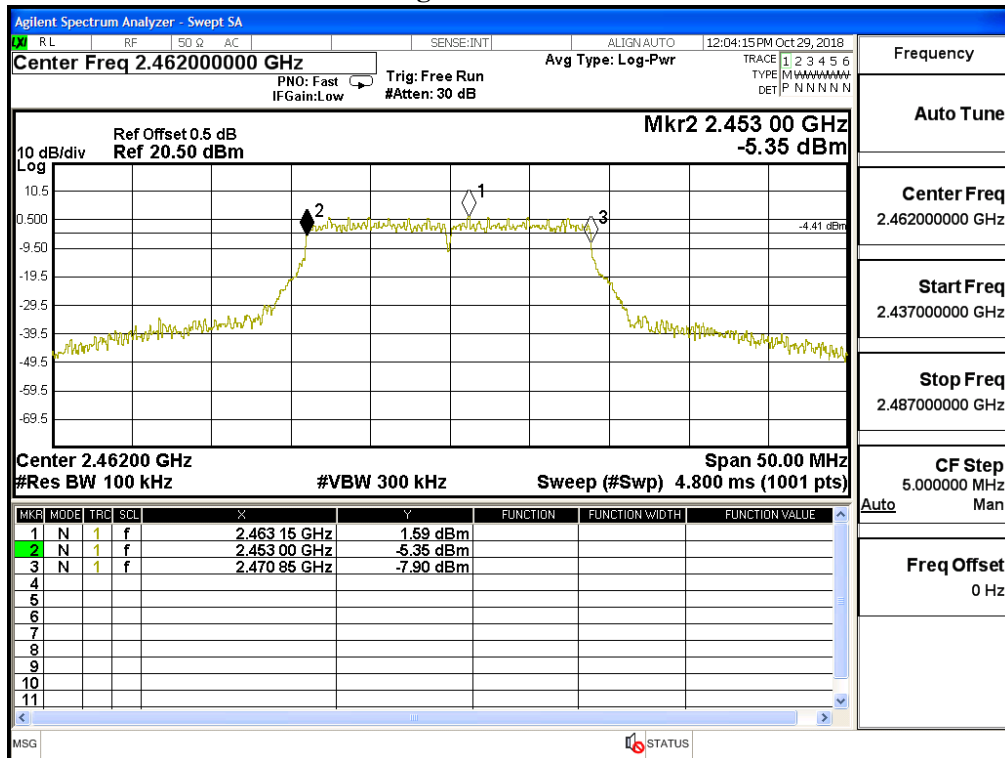

Figure Channel 11:



Product : STREAMING SOUNDBAR
 Test Item : 6dB Bandwidth Data
 Test Site : No.3 OATS
 Test Mode : Mode 4: Transmit (802.11n MCS0 15Mbps 40M-BW)

Channel No.	Frequency (MHz)	Measurement Level (kHz)	Required Limit (kHz)	Result
03	2422	36600	>500	Pass
06	2437	36600	>500	Pass
09	2452	36600	>500	Pass

Figure Channel 03:

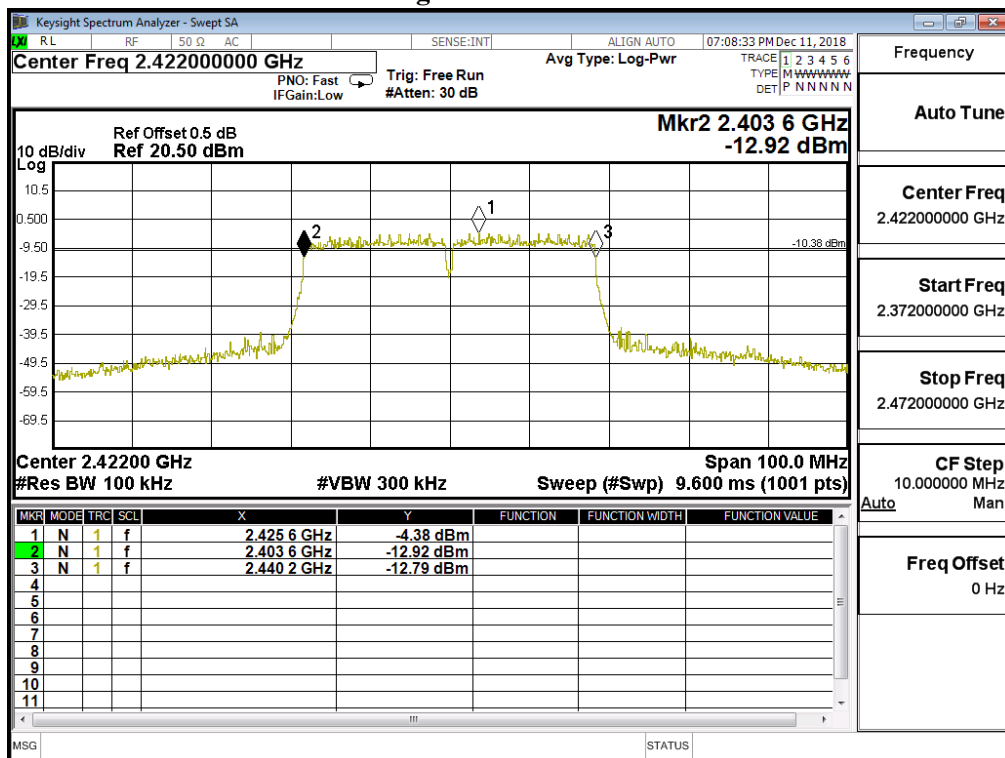

Figure Channel 06:

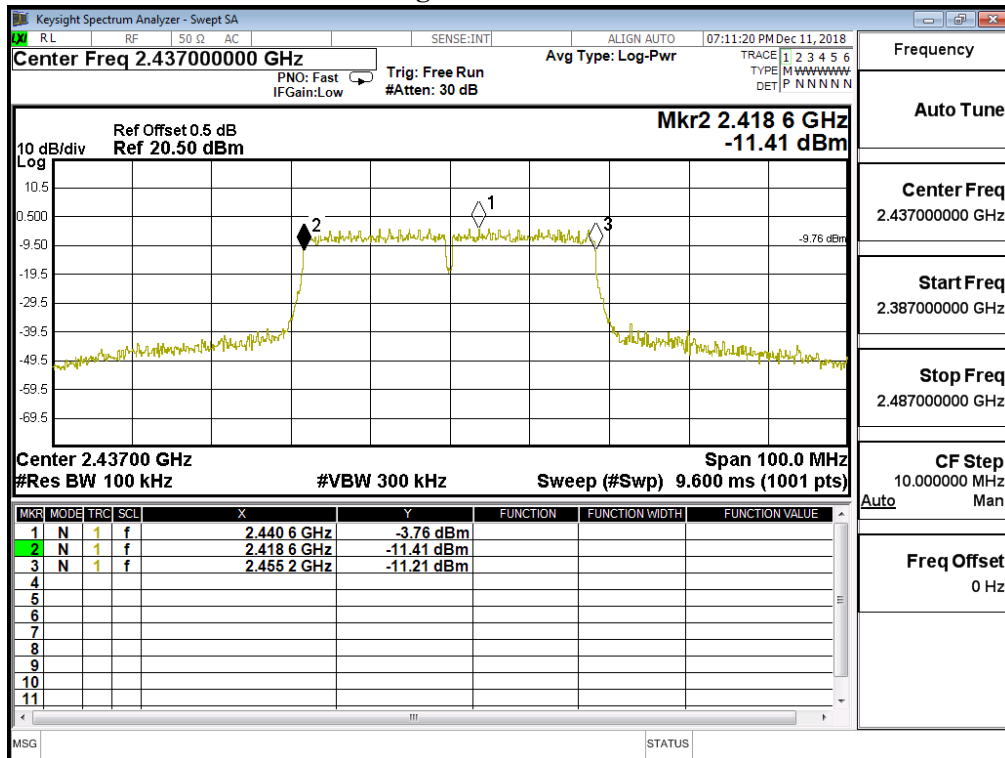
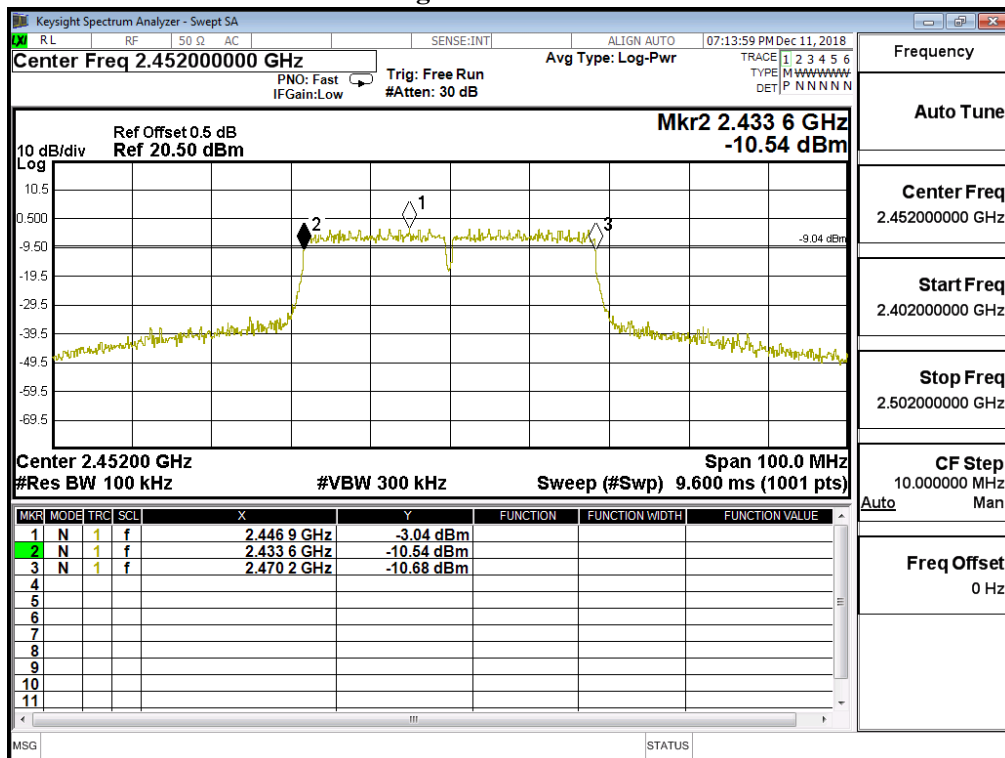
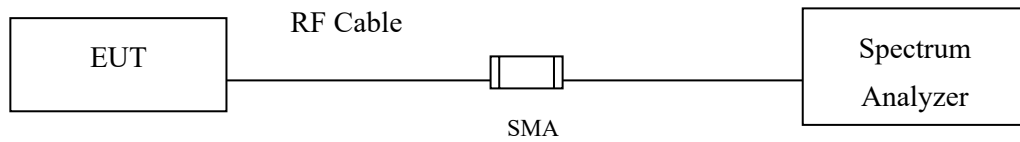

Figure Channel 09:



8. Power Density

8.1. Test Setup



8.2. Limits

The transmitted power density averaged over any 1 second interval shall not be greater +8dBm in any 3kHz bandwidth.

8.3. Test Procedure

The EUT was setup according to ANSI C63.10, 2013; tested according to DTS test procedure of KDB 558074 for compliance to FCC 47CFR 15.247 requirements.

The maximum power spectral density using KDB 558074 section 10.2 PKPSD (peak PSD) method.

8.4. Uncertainty

± 1.20 dB

8.5. Test Result of Power Density

Product : STREAMING SOUNDBAR
 Test Item : Power Density Data
 Test Site : No.3 OATS
 Test Mode : Mode 1: Transmit (802.11b 1Mbps)

Channel No.	Frequency (MHz)	Measure Level (dBm)	Limit (dBm)	Result
01	2412	6.140	≤ 8dBm	Pass
06	2437	7.480	≤ 8dBm	Pass
11	2462	6.690	≤ 8dBm	Pass

Figure Channel 01:

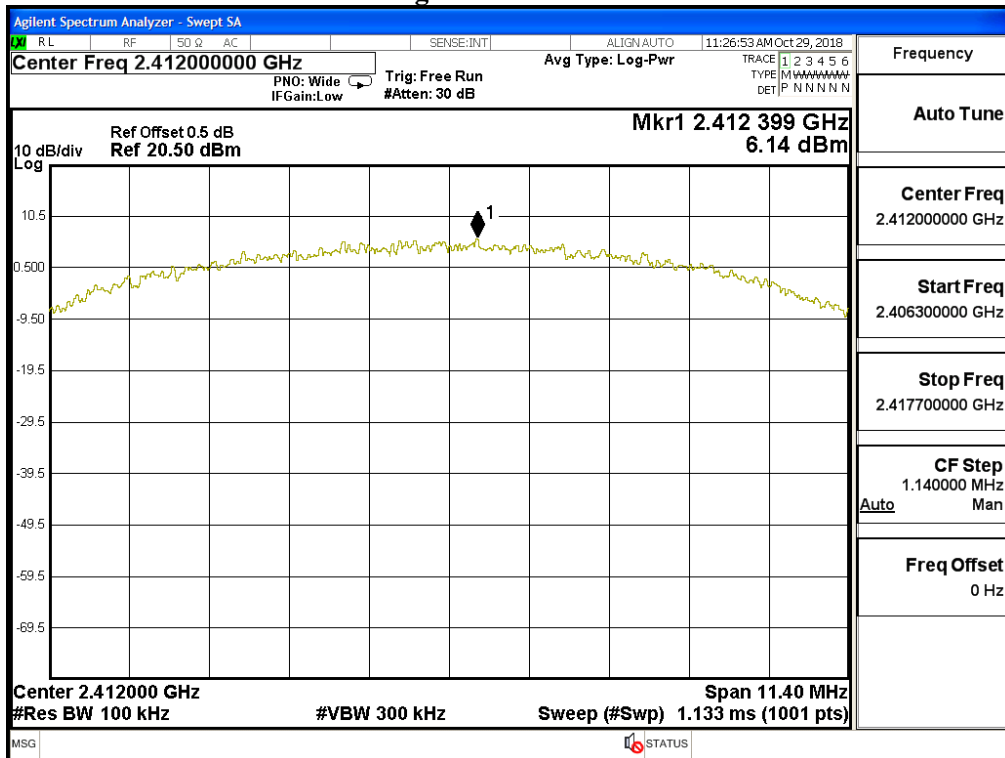

Figure Channel 06:

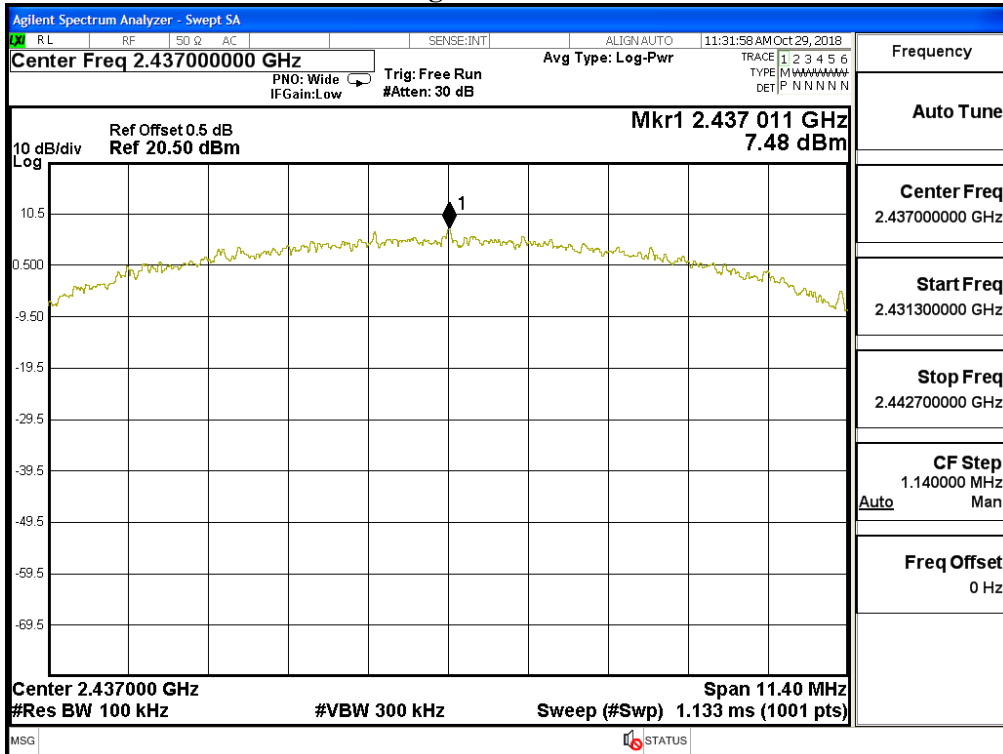
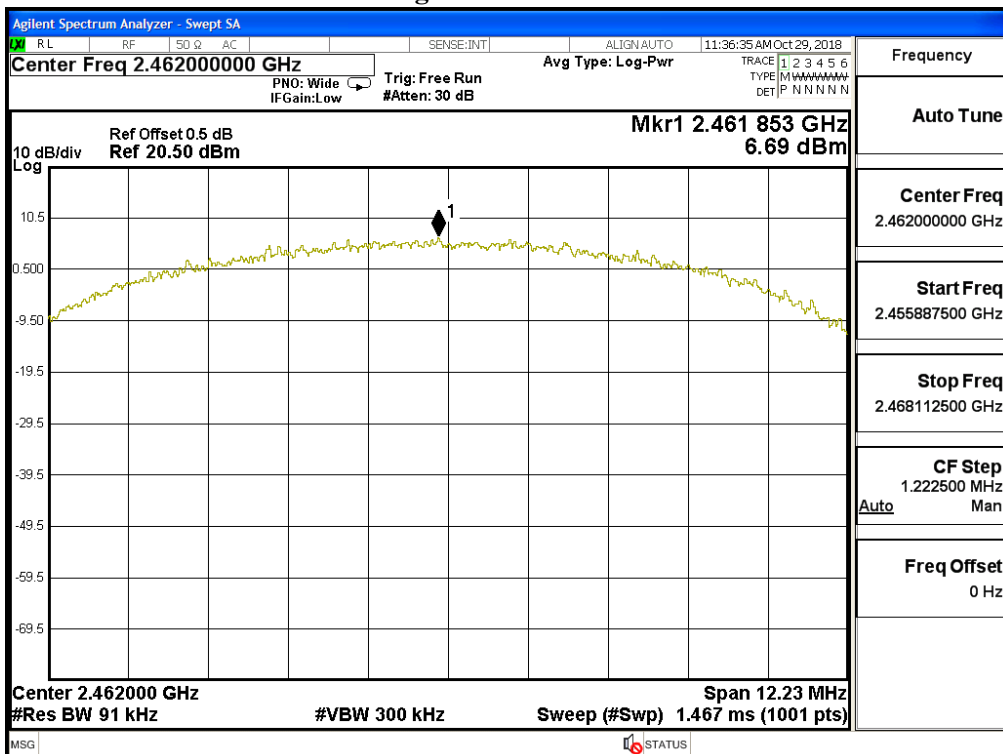

Figure Channel 11:



Product : STREAMING SOUNDBAR
 Test Item : Power Density Data
 Test Site : No.3 OATS
 Test Mode : Mode 2: Transmit (802.11g 6Mbps)

Channel No.	Frequency (MHz)	Measure Level (dBm)	Limit (dBm)	Result
01	2412	2.150	≤ 8dBm	Pass
06	2437	2.900	≤ 8dBm	Pass
11	2462	3.670	≤ 8dBm	Pass

Figure Channel 01:

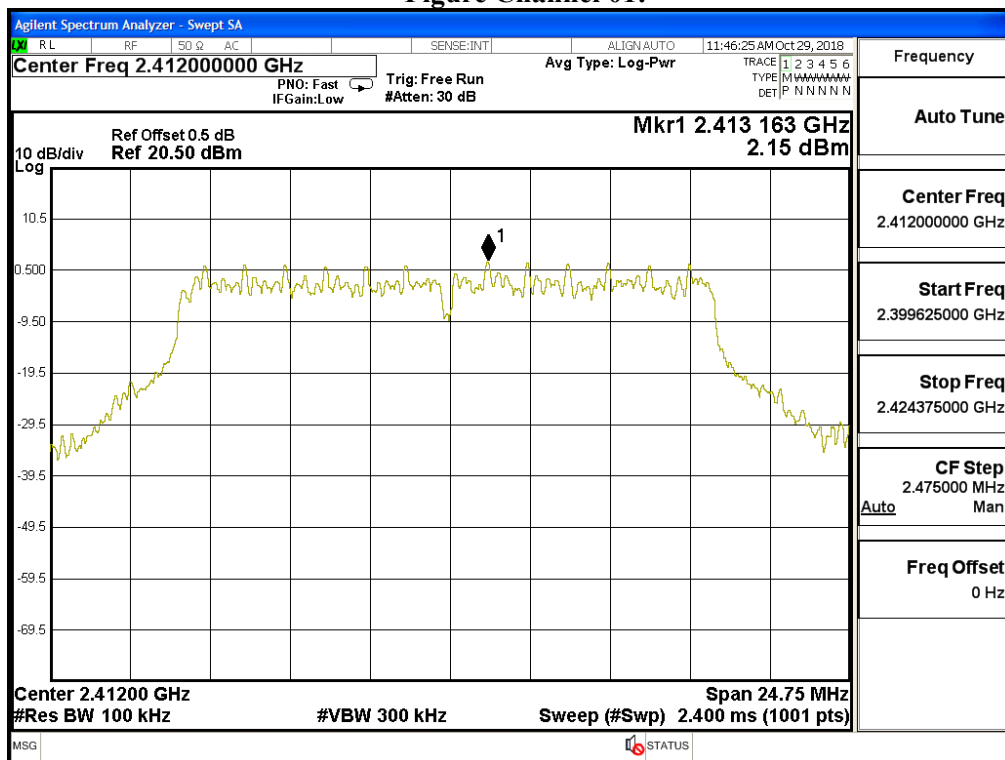

Figure Channel 06:

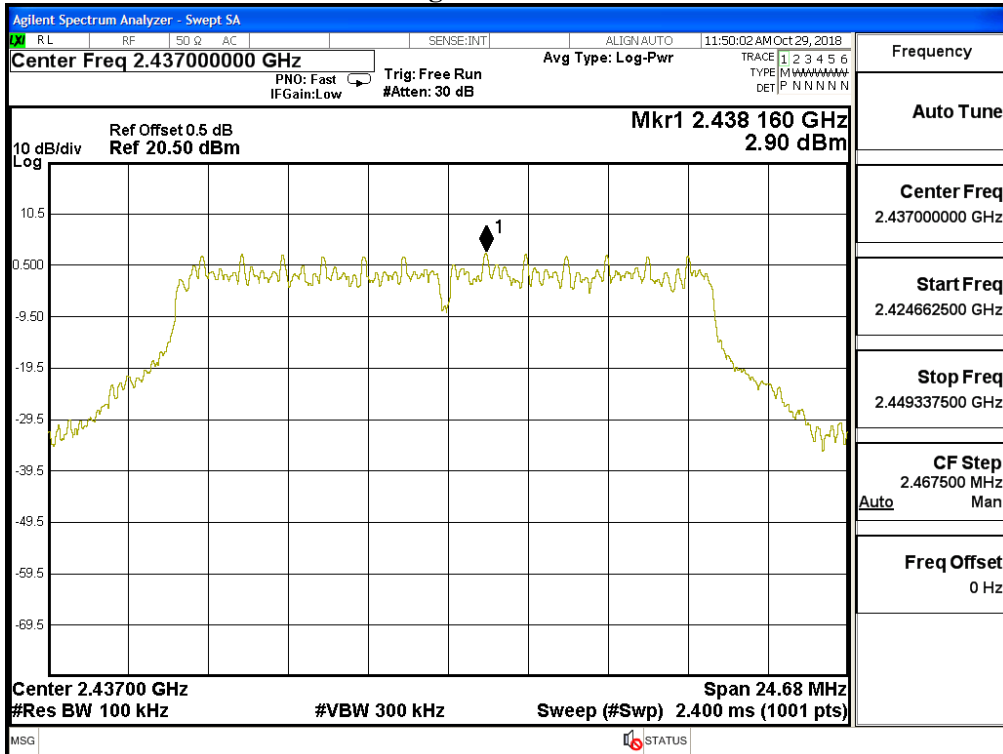
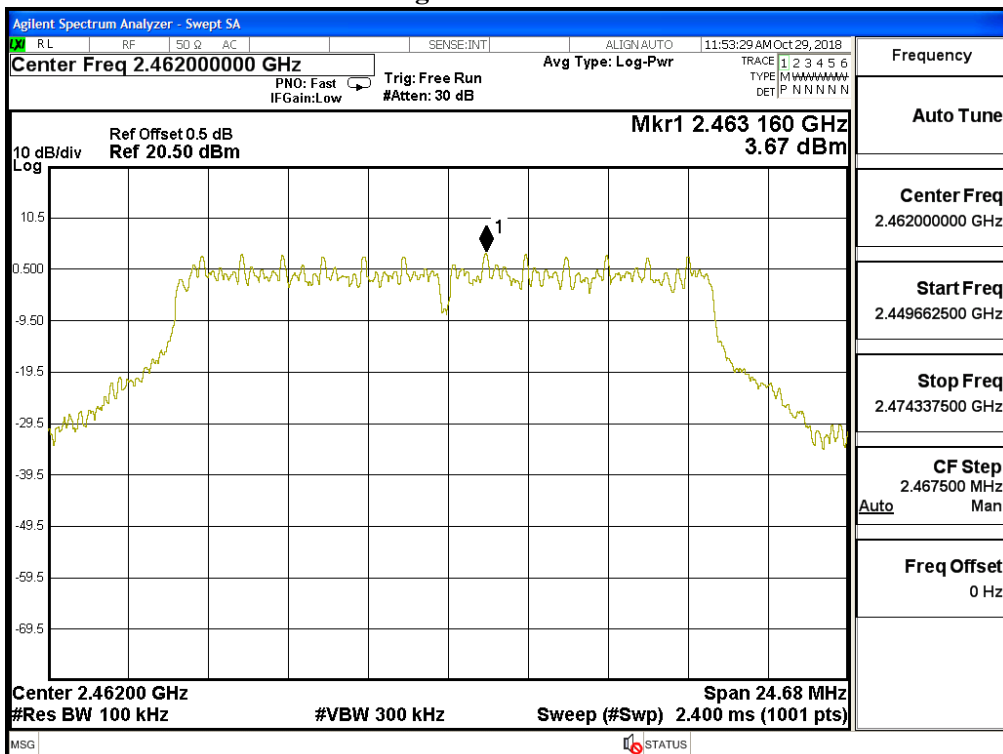

Figure Channel 11:



Product : STREAMING SOUNDBAR
 Test Item : Power Density Data
 Test Site : No.3 OATS
 Test Mode : Mode 3: Transmit (802.11n MCS0 7.2Mbps 20M-BW)

Channel No.	Frequency (MHz)	Measure Level (dBm)	Limit (dBm)	Result
01	2412	0.080	≤ 8dBm	Pass
06	2437	0.750	≤ 8dBm	Pass
11	2462	1.570	≤ 8dBm	Pass

Figure Channel 01:

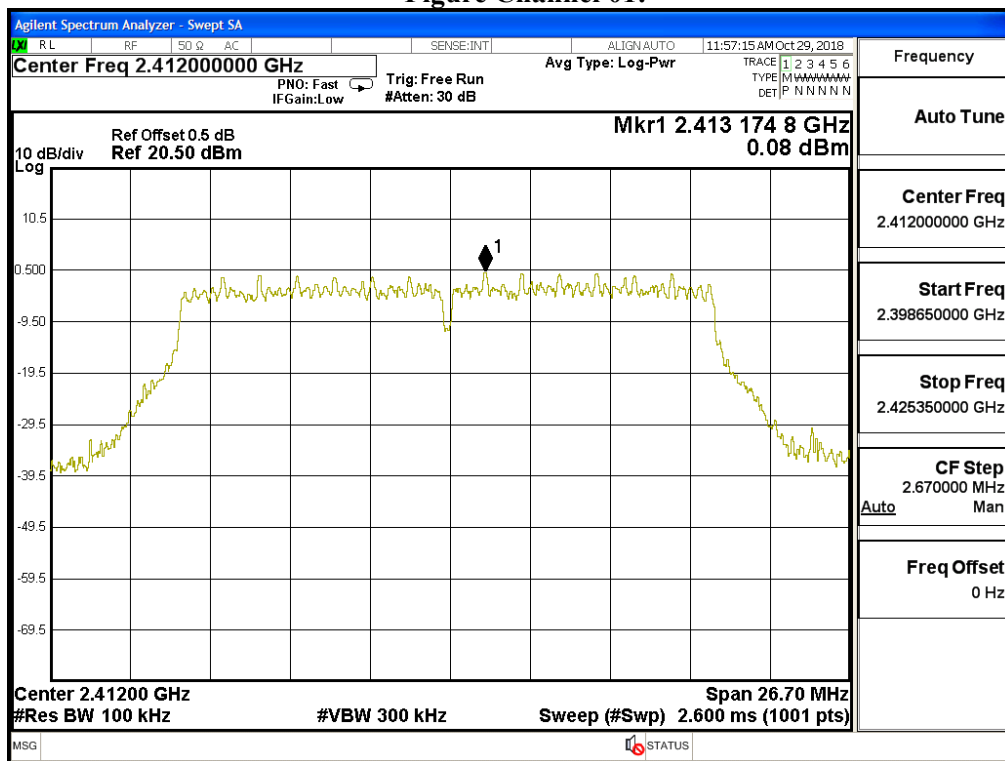

Figure Channel 06:

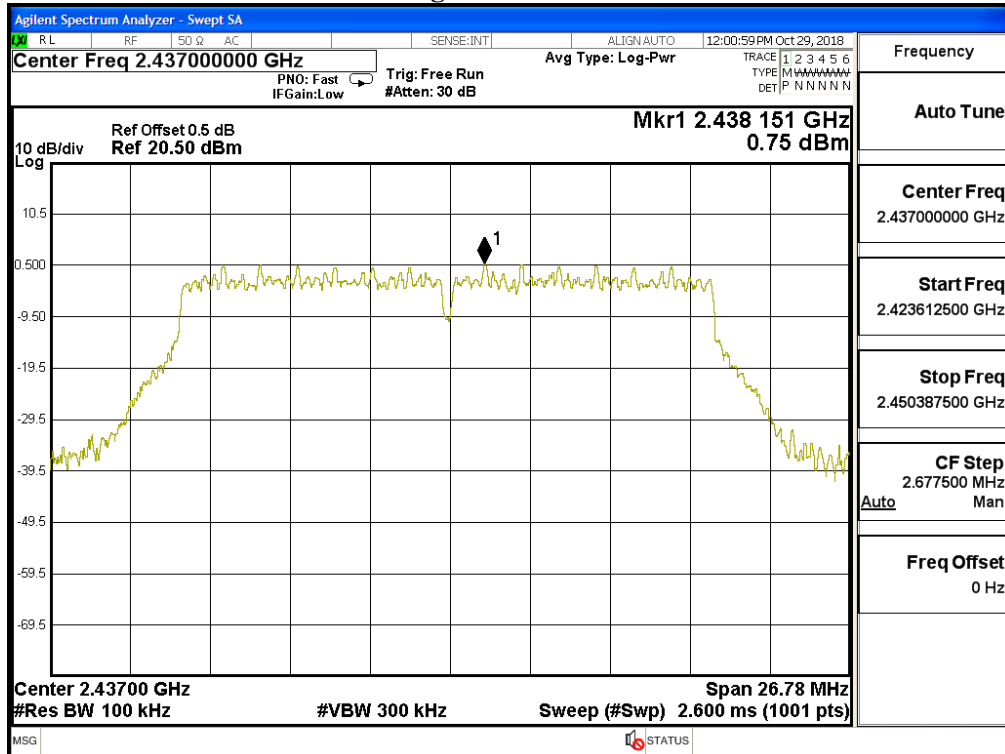
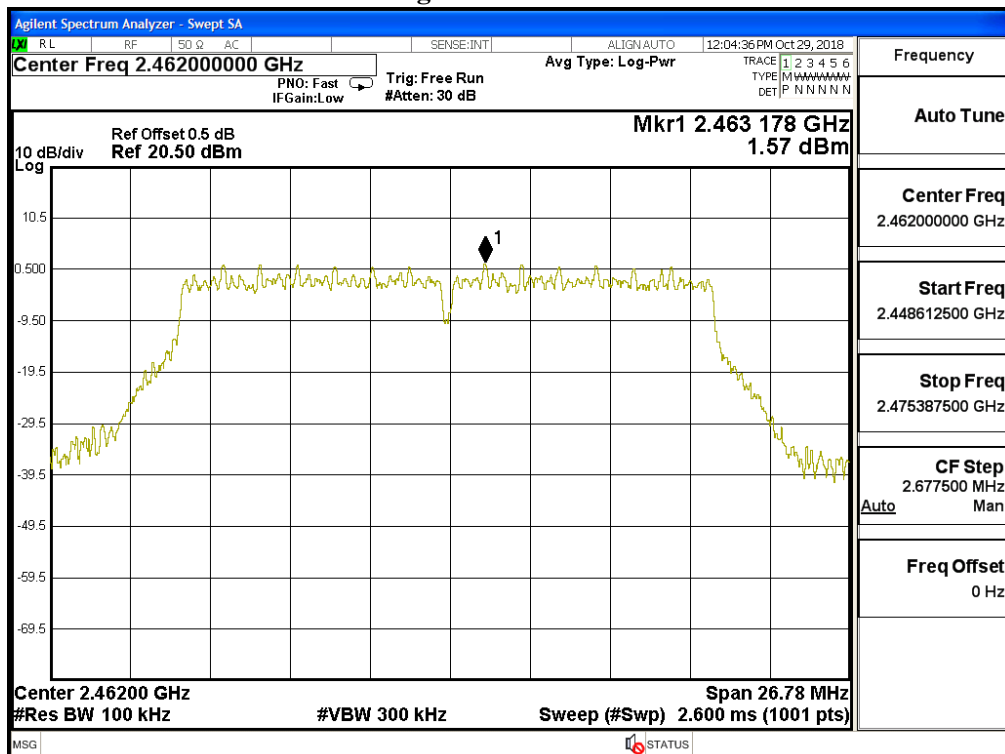

Figure Channel 11:



Product : STREAMING SOUNDBAR
 Test Item : Power Density Data
 Test Site : No.3 OATS
 Test Mode : Mode 4: Transmit (802.11n MCS0 15Mbps 40M-BW)

Channel No.	Frequency (MHz)	Measure Level (dBm)	Limit (dBm)	Result
03	2422	-4.430	≤ 8dBm	Pass
06	2437	-3.720	≤ 8dBm	Pass
09	2452	-3.040	≤ 8dBm	Pass

Figure Channel 03:

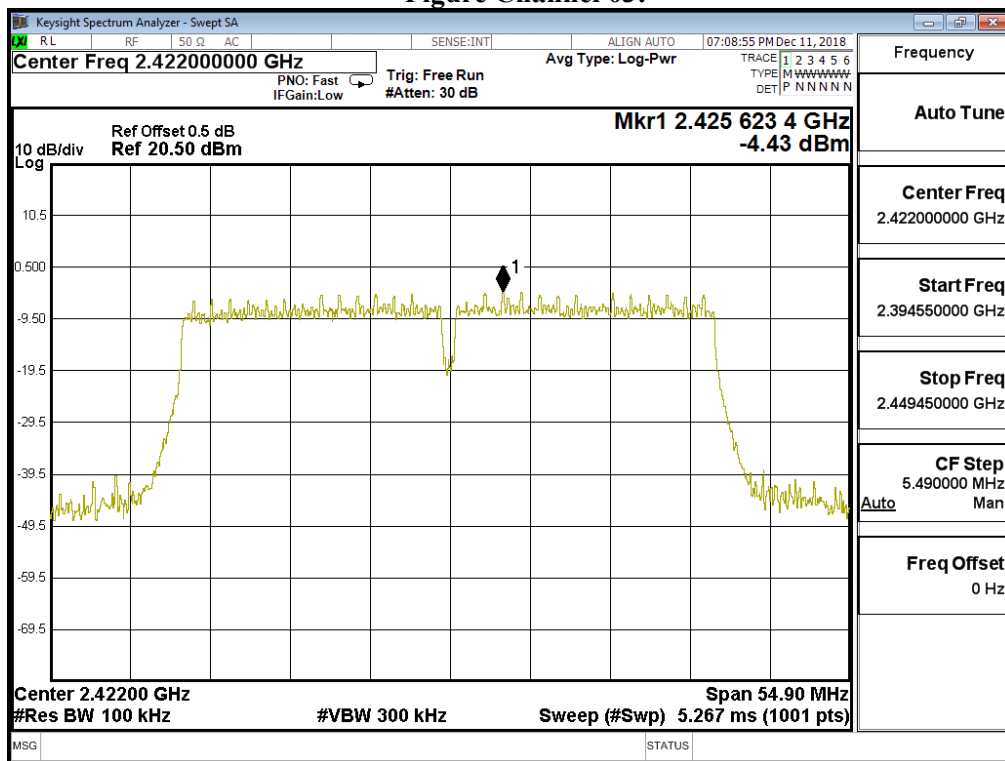

Figure Channel 06:

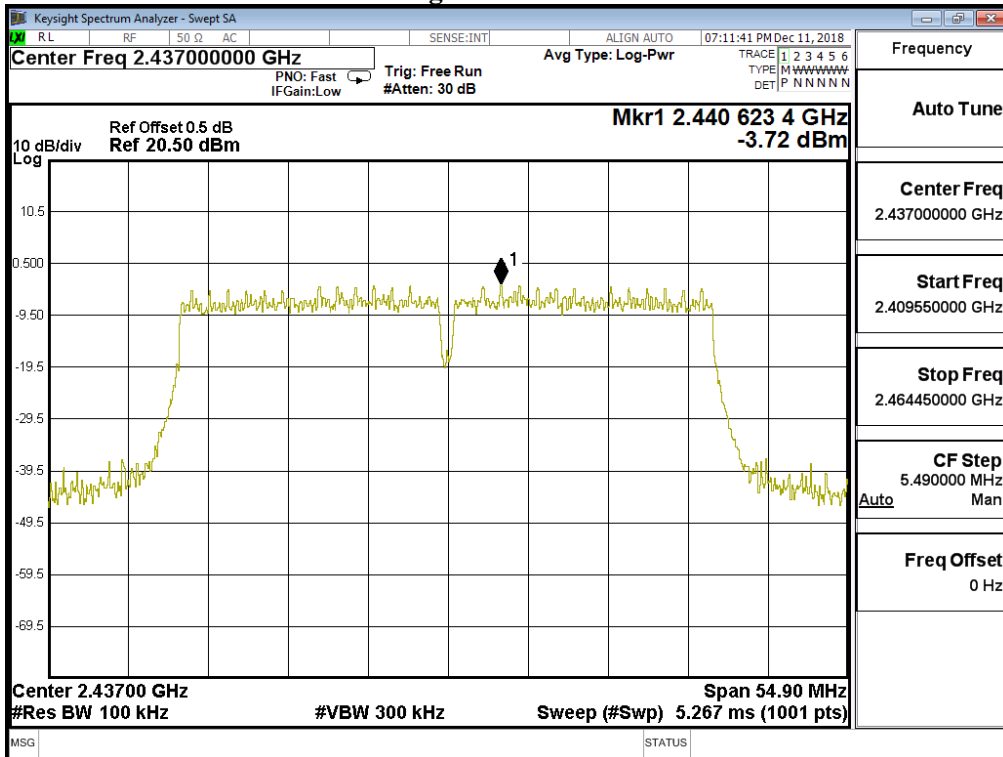
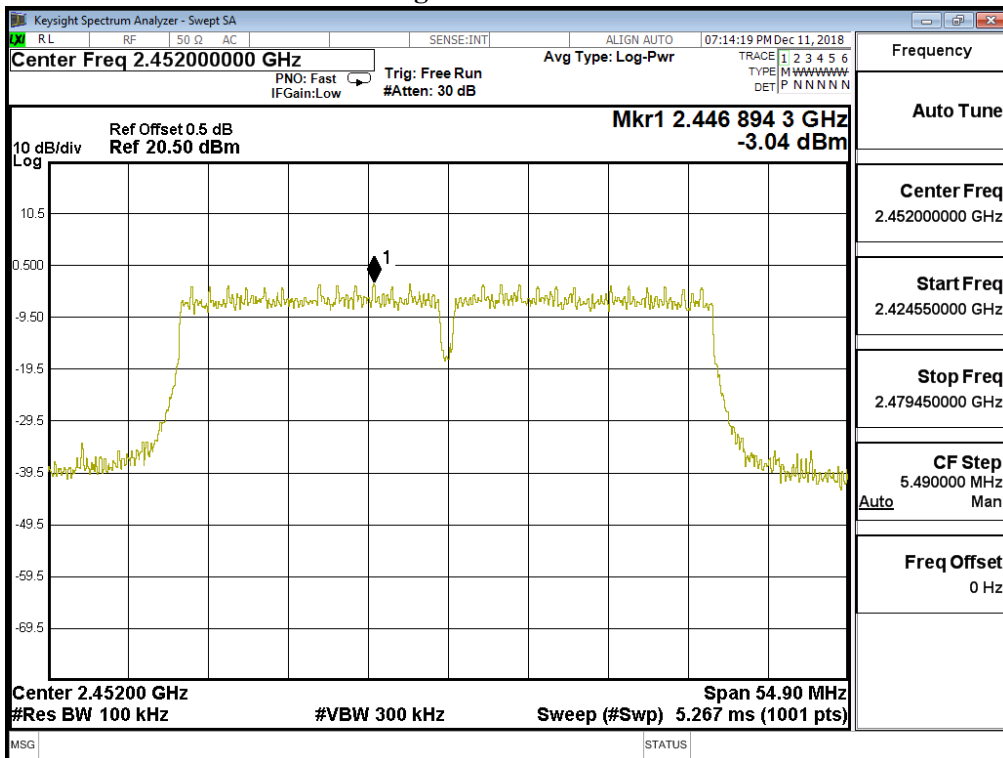
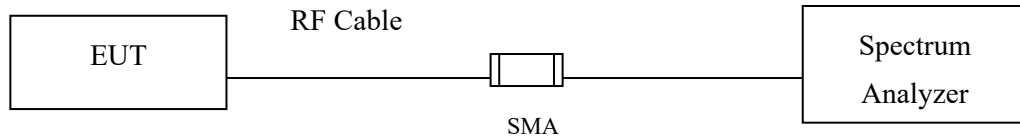

Figure Channel 09:



9. Duty Cycle

9.1. Test Setup



9.2. Test Procedure

The EUT was setup according to ANSI C63.10 2013; tested according to DTS test procedure of KDB558074 for compliance to FCC 47CFR 15.247 requirements.

9.3. Uncertainty

$\pm 2.31\text{msec}$

9.4. Test Result of Duty Cycle

Product : STREAMING SOUNDBAR
 Test Item : Duty Cycle
 Test Mode : Transmit

Duty Cycle Formula:

$$\text{Duty Cycle} = \text{Ton} / (\text{Ton} + \text{Toff})$$

$$\text{Duty Factor} = 10 \text{ Log} (1/\text{Duty Cycle})$$

Results:

2.4GHz band	Ton (ms)	Ton + Toff (ms)	Duty Cycle (%)	Duty Factor (dB)
802.11b	0.8400	0.9390	89.46	0.48
802.11g	0.1768	0.2784	63.51	1.97
802.11n20	0.1644	0.2669	61.60	2.10
802.11n40	0.1000	0.2029	49.29	3.07

802.11b

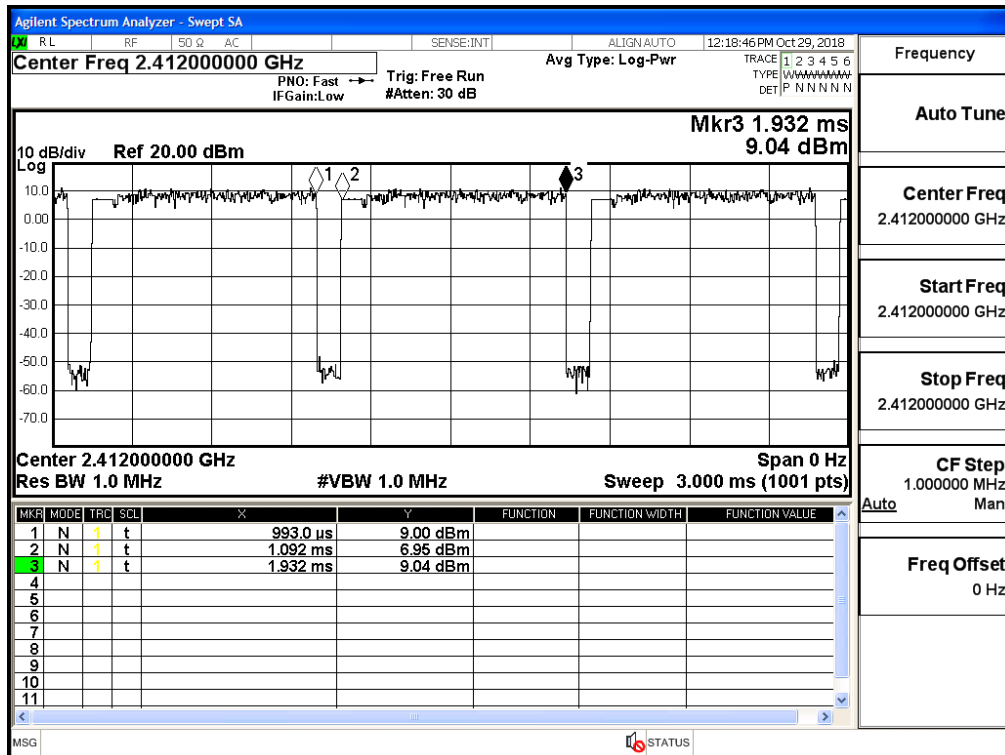

802.11g

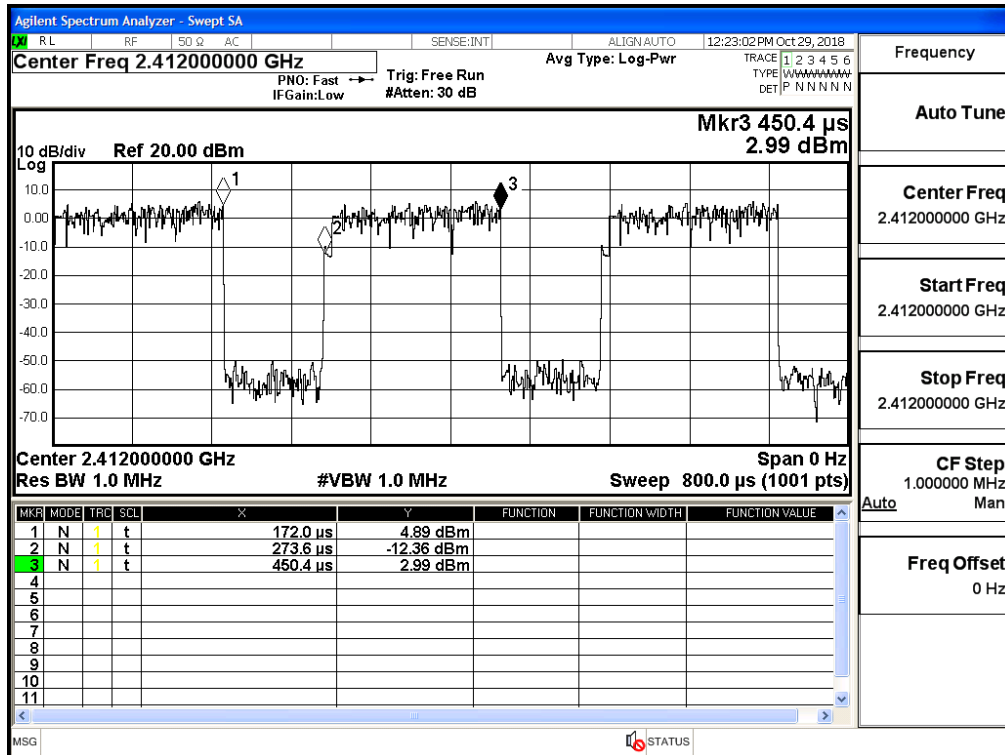

802.11n20

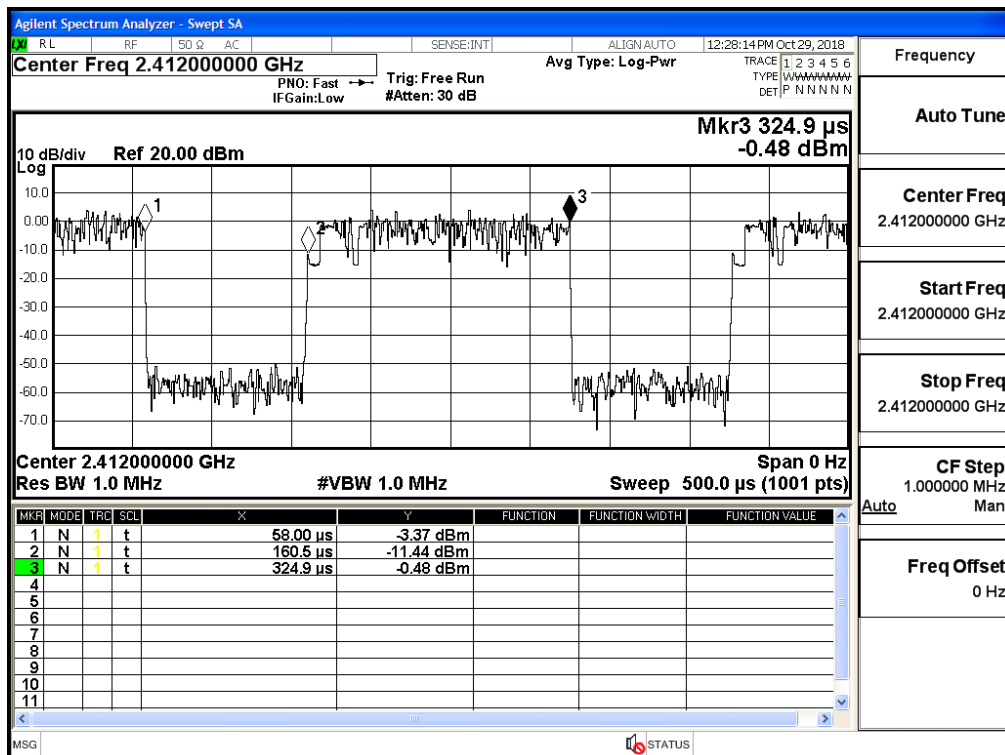

802.11n40

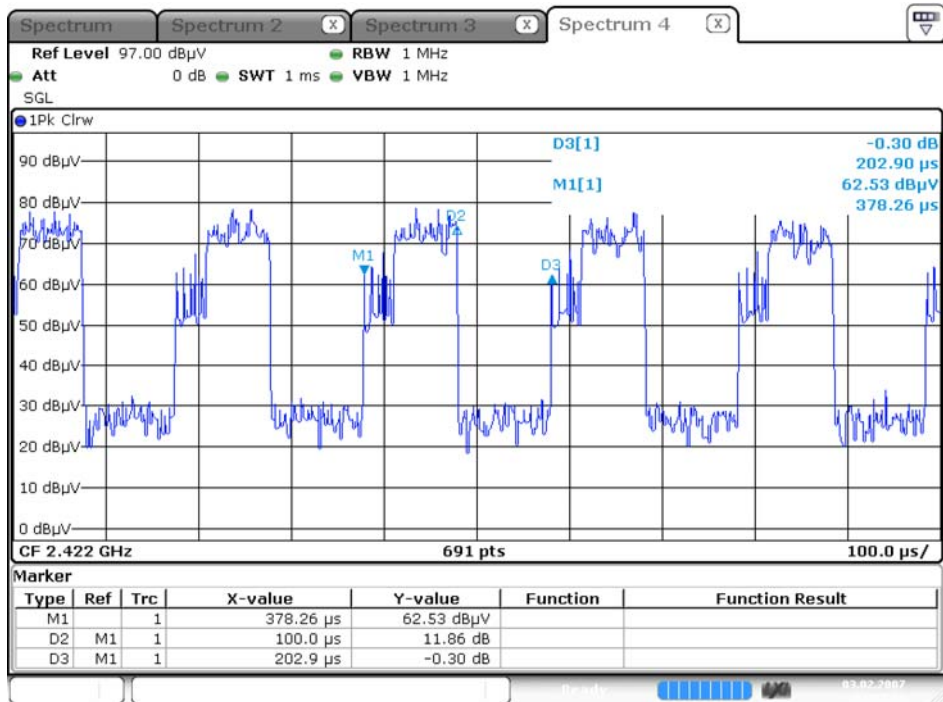

Date: 3.FEB.2007 23:31:23

10. EMI Reduction Method During Compliance Testing

No modification was made during testing.