



RADIO TEST REPORT

Report No: STS1611014F04

Issued for

EMATIC LIMITED

Unit 17, 9/F Tower A, New Mandarin Plaza NO, 14 Science
Museum Rd, TST, Hong Kong

| | |
|-----------------------|-----------------|
| Product Name: | X9 |
| Brand Name: | EXTREM |
| Model Name.: | X9 |
| Series Model: | N/A |
| FCC ID: | 2AJ9Z-X9 |
| Test Standard: | FCC Part 15.247 |

Any reproduction of this document must be done in full. No single part of this document may be reproduced without permission from STS, All Test Data Presented in this report is only applicable to presented Test sample.





TEST RESULT CERTIFICATION

Applicant's name: EMATIC LIMITED
Address: Unit 17, 9/F Tower A, New Mandarin Plaza NO, 14 Science Museum Rd, TST, Hong Kong
Manufacture's Name: EMATIC LIMITED
Address: Unit 17, 9/F Tower A, New Mandarin Plaza NO, 14 Science Museum Rd, TST, Hong Kong

Product description

Product name: X9
Model and/or type reference ..: X9
Serial Model: N/A

Standards: FCC Part15.247

Test procedure..... ANSI C63.10-2013

This device described above has been tested by STS, and the test results show that the equipment under test (EUT) is in compliance with the FCC requirements. And it is applicable only to the tested sample identified in the report.
 This report shall not be reproduced except in full, without the written approval of STS, this document may be altered or revised by STS, personal only, and shall be noted in the revision of the document.

Date of Test.....:

Date (s) of performance of tests: 02 Nov. 2016 ~03 Nov. 2016
Date of Issue.....: 04 Nov. 2016
Test Result: **Pass**

Testing Engineer : 

 (Tony Liu)

Technical Manager : 

 (Vita Li)

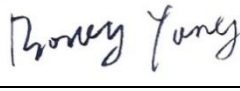
Authorized Signatory : 

 (Bovey Yang)





| Table of Contents | Page |
|---|-----------|
| 1. SUMMARY OF TEST RESULTS | 6 |
| 1.1 TEST FACTORY | 7 |
| 1.2 MEASUREMENT UNCERTAINTY | 7 |
| 2. GENERAL INFORMATION | 8 |
| 2.1 GENERAL DESCRIPTION OF EUT | 8 |
| 2.2 DESCRIPTION OF TEST MODES | 10 |
| 2.3 BLOCK DIGRAM SHOWING THE CONFIGURATION OF SYSTEM TEST | 11 |
| 2.4 DESCRIPTION OF SUPPORT UNITS | 12 |
| 2.5 EQUIPMENTS LIST FOR ALL TEST ITEMS | 13 |
| 3. EMC EMISSION TEST | 14 |
| 3.1 CONDUCTED EMISSION MEASUREMENT | 14 |
| 3.2 RADIATED EMISSION MEASUREMENT | 17 |
| 4. CONDUCTED SPURIOUS EMISSIONS | 29 |
| 4.1 APPLIED PROCEDURES / LIMIT | 29 |
| 4.2 TEST PROCEDURE | 29 |
| 4.3 DEVIATION FROM STANDARD | 29 |
| 4.4 TEST SETUP | 29 |
| 4.5 EUT OPERATION CONDITIONS | 29 |
| 4.6 TEST RESULTS | 30 |
| 5. POWER SPECTRAL DENSITY TEST | 42 |
| 5.1 APPLIED PROCEDURES / LIMIT | 42 |
| 5.2 TEST PROCEDURE | 42 |
| 5.3 DEVIATION FROM STANDARD | 42 |
| 5.4 TEST SETUP | 42 |
| 5.5 EUT OPERATION CONDITIONS | 42 |
| 5.6 TEST RESULTS | 42 |
| 6. BANDWIDTH TEST | 51 |
| 6.1 APPLIED PROCEDURES / LIMIT | 51 |
| 6.2 TEST PROCEDURE | 51 |
| 6.3 DEVIATION FROM STANDARD | 51 |
| 6.4 TEST SETUP | 51 |
| 6.5 EUT OPERATION CONDITIONS | 51 |
| 6.6 TEST RESULTS | 52 |



| Table of Contents | Page |
|--|-----------|
| 7. PEAK OUTPUT POWER TEST | 60 |
| 7.1 APPLIED PROCEDURES / LIMIT | 60 |
| 7.2 TEST PROCEDURE | 60 |
| 7.3 DEVIATION FROM STANDARD | 60 |
| 7.4 TEST SETUP | 60 |
| 7.5 EUT OPERATION CONDITIONS | 60 |
| 7.6 TEST RESULTS | 61 |
| 8. ANTENNA REQUIREMENT | 62 |
| 8.1 STANDARD REQUIREMENT | 62 |
| 8.2 EUT ANTENNA | 62 |
| APPENDIX - PHOTOS OF TEST SETUP | 63 |

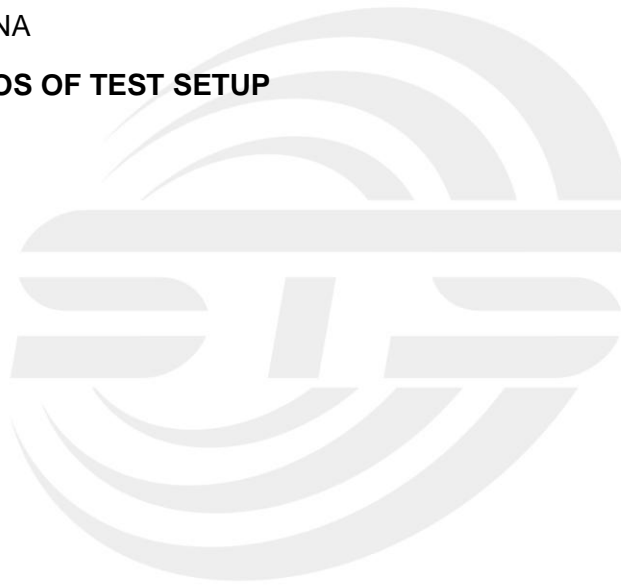



Revision History

| Rev. | Issue Date | Report NO. | Effect Page | Contents |
|------|--------------|---------------|-------------|---------------|
| 00 | 04 Nov. 2016 | STS1611014F04 | ALL | Initial Issue |
| | | | | |





1. SUMMARY OF TEST RESULTS

Test procedures according to the technical standards:
KDB 558074 D01 DTS Meas Guidance v03r05

| FCC Part 15.247, Subpart C | | | |
|----------------------------|---|----------|--------|
| Standard Section | Test Item | Judgment | Remark |
| 15.207 | Conducted Emission | PASS | |
| 15.247 (a)(2) | 6dB Bandwidth | PASS | |
| 15.247 (b)(3) | Output Power | PASS | |
| 15.247 (c) | Radiated Spurious Emission | PASS | |
| 15.247 (d) | Conducted Spurious & Band Edge Emission | PASS | |
| 15.247 (e) | Power Spectral Density | PASS | |
| 15.205 | Radiated Band Edge Emission | PASS | |
| 15.203 | Antenna Requirement | PASS | |

NOTE:

(1) "N/A" denotes test is not applicable in this Test Report



1.1 TEST FACTORY

Shenzhen STS Test Services Co., Ltd.

Add. : 1/F., Building B, Zhuoke Science Park, No.190, Chongqing Road,
Fuyong Street, Bao'an District, Shenzhen, Guangdong, China

CNAS Registration No.: L7649;

FCC Registration No.: 842334; IC Registration No.: 12108A-1

1.2 MEASUREMENT UNCERTAINTY

The reported uncertainty of measurement $y \pm U$, where expanded uncertainty U is based on a standard uncertainty multiplied by a coverage factor of $k=2$, providing a level of confidence of approximately 95 %.

| No. | Item | Uncertainty |
|-----|--|---------------------------|
| 1 | Conducted Emission (9KHz-150KHz) | $\pm 2.88\text{dB}$ |
| 2 | Conducted Emission (150KHz-30MHz) | $\pm 2.67\text{dB}$ |
| 3 | RF power,conducted | $\pm 0.70\text{dB}$ |
| 4 | Spurious emissions,conducted | $\pm 1.19\text{dB}$ |
| 5 | All emissions,radiated(<1G) 30MHz-200MHz | $\pm 2.83\text{dB}$ |
| 6 | All emissions,radiated(<1G) 200MHz-1000MHz | $\pm 2.94\text{dB}$ |
| 7 | All emissions,radiated(>1G) | $\pm 3.03\text{dB}$ |
| 8 | Temperature | $\pm 0.5^{\circ}\text{C}$ |
| 9 | Humidity | $\pm 2\%$ |



2. GENERAL INFORMATION

2.1 GENERAL DESCRIPTION OF EUT

| | | | | | | | | | | | | | |
|-------------------------|---|----------------------|---|------------------|----------------------|-------------------------|---|-------------------|--|----------------------|--------------------|--------------------|---------|
| Equipment | X9 | | | | | | | | | | | | |
| Trade Name | EXTREM | | | | | | | | | | | | |
| Model Name | X9 | | | | | | | | | | | | |
| Serial Model | N/A | | | | | | | | | | | | |
| Model Difference | N/A | | | | | | | | | | | | |
| Product Description | <p>The EUT is a X9</p> <table border="1"><tr><td>Operation Frequency:</td><td>802.11b/g/n 20: 2412~2462 MHz 802.11n 40: 2422~2452MHz</td></tr><tr><td>Modulation Type:</td><td>CCK/OFDM/DBPSK/DAPSK</td></tr><tr><td>Bit Rate of Transmitter</td><td>802.11b:11/5.5/2/1 Mbps 802.11g:54/48/36/24/18/12/9/6Mbps 802.11n(20/40MHz):300/150/144.44/130/ 117/115.56/104/86.67/78/52/6.5Mbps</td></tr><tr><td>Number Of Channel</td><td>802.11b/g/n20: 11CH 802.11n 40: 7CH</td></tr><tr><td>Antenna Designation:</td><td>Please see Note 3.</td></tr><tr><td>Antenna Gain (dBi)</td><td>0.5 dbi</td></tr></table> | Operation Frequency: | 802.11b/g/n 20: 2412~2462 MHz 802.11n 40: 2422~2452MHz | Modulation Type: | CCK/OFDM/DBPSK/DAPSK | Bit Rate of Transmitter | 802.11b:11/5.5/2/1 Mbps 802.11g:54/48/36/24/18/12/9/6Mbps 802.11n(20/40MHz):300/150/144.44/130/ 117/115.56/104/86.67/78/52/6.5Mbps | Number Of Channel | 802.11b/g/n20: 11CH 802.11n 40: 7CH | Antenna Designation: | Please see Note 3. | Antenna Gain (dBi) | 0.5 dbi |
| Operation Frequency: | 802.11b/g/n 20: 2412~2462 MHz 802.11n 40: 2422~2452MHz | | | | | | | | | | | | |
| Modulation Type: | CCK/OFDM/DBPSK/DAPSK | | | | | | | | | | | | |
| Bit Rate of Transmitter | 802.11b:11/5.5/2/1 Mbps 802.11g:54/48/36/24/18/12/9/6Mbps 802.11n(20/40MHz):300/150/144.44/130/ 117/115.56/104/86.67/78/52/6.5Mbps | | | | | | | | | | | | |
| Number Of Channel | 802.11b/g/n20: 11CH 802.11n 40: 7CH | | | | | | | | | | | | |
| Antenna Designation: | Please see Note 3. | | | | | | | | | | | | |
| Antenna Gain (dBi) | 0.5 dbi | | | | | | | | | | | | |
| Channel List | Please refer to the Note 2. | | | | | | | | | | | | |
| Ratings | DC 3.7V from battery | | | | | | | | | | | | |
| Adapter | Input: AC100-240V, 200mA, 50/60 Hz Output: DC 5V, 1000mA | | | | | | | | | | | | |
| Battery | Rated Voltage: 3.7V Capacity : 4200mAh | | | | | | | | | | | | |
| Hardware version number | V1.1 | | | | | | | | | | | | |
| Software version number | MT6582_X9_1.3_04_20160725 | | | | | | | | | | | | |
| Connecting I/O Port(s) | Please refer to the User's Manual | | | | | | | | | | | | |

Note:

- 1 For a more detailed features description, please refer to the manufacturer's specifications or the User's Manual.



2

| Channel List for 802.11b/g/n(20MHz) | | | | | | | |
|-------------------------------------|-----------------|---------|-----------------|---------|-----------------|---------|-----------------|
| Channel | Frequency (MHz) | Channel | Frequency (MHz) | Channel | Frequency (MHz) | Channel | Frequency (MHz) |
| 01 | 2412 | 04 | 2427 | 07 | 2442 | 10 | 2457 |
| 02 | 2417 | 05 | 2432 | 08 | 2447 | 11 | 2462 |
| 03 | 2422 | 06 | 2437 | 09 | 2452 | | |

| Channel List for 802.11n(40MHz) | | | | | | | |
|---------------------------------|-----------------|---------|-----------------|---------|-----------------|---------|-----------------|
| Channel | Frequency (MHz) | Channel | Frequency (MHz) | Channel | Frequency (MHz) | Channel | Frequency (MHz) |
| 03 | 2422 | 06 | 2437 | 09 | 2452 | | |
| 04 | 2427 | 07 | 2442 | | | | |
| 05 | 2432 | 08 | 2447 | | | | |

3 Table for Filed Antenna

| Ant. | Brand | Model Name | Antenna Type | Connector | Gain (dBi) | NOTE |
|------|--------|------------|--------------|-----------|------------|------|
| A | EXTREM | X9 | PIFA Antenna | N/A | 0.5 | N/A |



2.2 DESCRIPTION OF TEST MODES

To investigate the maximum EMI emission characteristics generated from EUT, the test system was pre-scanning tested based on the consideration of following EUT operation mode or test configuration mode which possibly have effect on EMI emission level. Each of these EUT operation mode(s) or test configuration mode(s) mentioned above was evaluated respectively.

| Pretest Mode | Description |
|--------------|----------------------------|
| Mode 1 | Low |
| Mode 2 | Middle |
| Mode 3 | High |
| Mode 4 | Charging + Keeping TX mode |

| For Conducted Emission | |
|------------------------|----------------------------|
| Final Test Mode | Description |
| Mode 4 | Charging + Keeping TX mode |

| For Radiated Emission | |
|-----------------------|----------------------------|
| Final Test Mode | Description |
| Mode 1 | Low |
| Mode 2 | Middle |
| Mode 3 | High |
| Mode 4 | Charging + Keeping TX mode |

Note:

- (1) The measurements are performed at the highest, middle, lowest available channels.
- (2) The measurements are performed at all Bit Rate of Transmitter, the worst data was reported
- (3) We have been tested for all available U.S. voltage and frequencies (For 120V, 50/60Hz and 240V, 50/60Hz) for which the device is capable of operation.

2.3 BLOCK DIGRAM SHOWING THE CONFIGURATION OF SYSTEM TEST

Radiated Spurious Emission Test

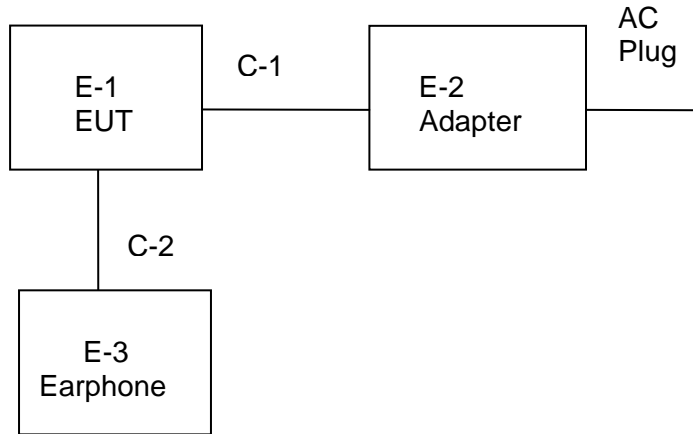

Conducted Emission Test

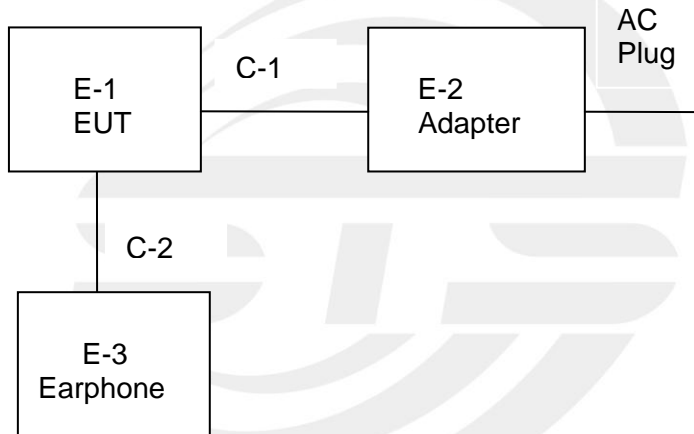



2.4 DESCRIPTION OF SUPPORT UNITS

The EUT has been tested as an independent unit together with other necessary accessories or support units. The following support units or accessories were used to form a representative test configuration during the tests.

| Item | Equipment | Mfr/Brand | Model/Type No. | Series No. | Note |
|------|-----------|-----------|----------------|------------|------|
| E-1 | X9 | EXTREM | X9 | N/A | EUT |
| E-2 | Adapter | N/A | UT-107A-UB22-Y | N/A | EUT |
| E-3 | Earphone | N/A | N/A | N/A | EUT |
| | | | | | |
| | | | | | |
| | | | | | |

| Item | Shielded Type | Ferrite Core | Length | Note |
|------|---------------|--------------|--------|------|
| C-1 | Unshielded | NO | 100cm | N/A |
| C-2 | Unshielded | NO | 120cm | N/A |
| | | | | |
| | | | | |
| | | | | |

Note:

- (1) The support equipment was authorized by Declaration of Confirmation.
- (2) For detachable type I/O cable should be specified the length in cm in 『Length』 column.



2.5 EQUIPMENTS LIST FOR ALL TEST ITEMS

Radiation Test equipment

| Kind of Equipment | Manufacturer | Type No. | Serial No. | Last calibration | Calibrated until |
|-----------------------|--------------|------------------|----------------|------------------|------------------|
| Spectrum Analyzer | Agilent | E4407B | MY50140340 | 2016.10.23 | 2017.10.22 |
| Test Receiver | R&S | ESCI | 101427 | 2016.10.23 | 2017.10.22 |
| Bilog Antenna | TESEQ | CBL6111D | 34678 | 2014.11.24 | 2017.11.23 |
| Horn Antenna | Schwarzbeck | BBHA 9120D(1201) | 9120D-1343 | 2015.03.05 | 2018.03.04 |
| Horn Antenna | Schwarzbeck | BBHA 9170 | 9170-0741 | 2016.03.06 | 2019.03.03 |
| 50Ω Coaxial Switch | Anritsu | MP59B | 6200264416 | 2016.06.06 | 2017.06.05 |
| PreAmplifier | Agilent | 8449B | 60538 | 2016.10.23 | 2017.10.22 |
| Loop Antenna | EMCO | 6502 | 9003-2485 | 2016.03.06 | 2019.03.03 |
| Preamplifier | Agilent | 8449B | 60538 | 2016.10.23 | 2017.10.22 |
| Low frequency cable | EM | R01 | N/A | NCR | NCR |
| High frequency cable | SCHWARZBECK | AK9515H | SN-96286/96287 | NCR | NCR |
| Semi-anechoic chamber | Changling | 966 | N/A | 2016.10.23 | 2017.10.22 |

Conduction Test equipment

| Kind of Equipment | Manufacturer | Type No. | Serial No. | Last calibration | Calibrated until |
|-------------------|--------------|----------|------------|------------------|------------------|
| EMI Test Receiver | R&S | ESPI | 102086 | 2016.10.23 | 2017.10.22 |
| LISN | R&S | ENV216 | 101242 | 2016.10.23 | 2017.10.22 |
| LISN | EMCO | 3810/2NM | 000-23625 | 2016.10.23 | 2017.10.22 |
| Conduction Cable | EM | C01 | N/A | NCR | NCR |
| Shielding Room | Changling | 854 | N/A | 2016.10.23 | 2017.10.22 |

RF Connected Test

| Kind of Equipment | Manufacturer | Type No. | Serial No. | Last calibration | Calibrated until |
|---------------------|--------------|----------|---------------|------------------|------------------|
| USB RF power sensor | DARE | RPR3006W | 15I00041SNO03 | 2016.10.23 | 2017.10.22 |
| Spectrum Analyzer | Agilent | E4407B | MY50140340 | 2016.10.23 | 2017.10.22 |
| Signal Analyzer | Agilent | N9020A | MY49100060 | 2016.10.23 | 2017.10.22 |



3. EMC EMISSION TEST

3.1 CONDUCTED EMISSION MEASUREMENT

3.1.1 POWER LINE CONDUCTED EMISSION LIMITS

Operating frequency band. In case the emission fall within the restricted band specified on Part 15.247&207(a) limit in the table below has to be followed.

| FREQUENCY (MHz) | Class B (dBuV) | | Standard |
|-----------------|----------------|-----------|----------|
| | Quasi-peak | Average | |
| 0.15 -0.5 | 66 - 56 * | 56 - 46 * | CISPR |
| 0.50 -5.0 | 56.00 | 46.00 | CISPR |
| 5.0 -30.0 | 60.00 | 50.00 | CISPR |

| | | | |
|-----------|-----------|-----------|-----|
| 0.15 -0.5 | 66 - 56 * | 56 - 46 * | FCC |
| 0.50 -5.0 | 56.00 | 46.00 | FCC |
| 5.0 -30.0 | 60.00 | 50.00 | FCC |

Note:

- (1) The tighter limit applies at the band edges.
- (2) The limit of " * " marked band means the limitation decreases linearly with the logarithm of the frequency in the range.

The following table is the setting of the receiver



3.1.2 TEST RESULT

| | | | |
|---------------|-----------------------------------|--------------------|--------|
| Temperature: | 26 °C | Relative Humidity: | 54% |
| Pressure: | 1010hPa | Phase: | L |
| Test Voltage: | DC 5V from Adapter AC120V/60Hz | Test Mode: | Mode 4 |

| Frequency (MHz) | Reading (dBuV) | Correct Factor(dB) | Result (dBuV) | Limit (dBuV) | Margin (dB) | Remark |
|-----------------|----------------|--------------------|---------------|--------------|-------------|--------|
| 0.1685 | 50.32 | 10.00 | 60.32 | 65.03 | -4.71 | QP |
| 0.1685 | 30.53 | 10.00 | 40.53 | 55.03 | -14.50 | AVG |
| 0.2540 | 45.07 | 9.95 | 55.02 | 61.63 | -6.61 | QP |
| 0.2540 | 25.60 | 9.95 | 35.55 | 51.63 | -16.08 | AVG |
| 0.4700 | 41.45 | 9.99 | 51.44 | 56.51 | -5.07 | QP |
| 0.4700 | 17.49 | 9.99 | 27.48 | 46.51 | -19.03 | AVG |
| 0.9820 | 41.78 | 9.91 | 51.69 | 56.00 | -4.31 | QP |
| 0.9820 | 21.28 | 9.91 | 31.19 | 46.00 | -14.81 | AVG |
| 2.6340 | 41.44 | 10.00 | 51.44 | 56.00 | -4.56 | QP |
| 2.6340 | 21.34 | 10.00 | 31.34 | 46.00 | -14.66 | AVG |
| 5.8340 | 40.52 | 10.20 | 50.72 | 60.00 | -9.28 | QP |
| 5.8340 | 15.72 | 10.20 | 25.92 | 50.00 | -24.08 | AVG |

Remark:

1. Factor = Antenna Factor + Cable Loss – Pre-amplifier.

100.0 dBuV

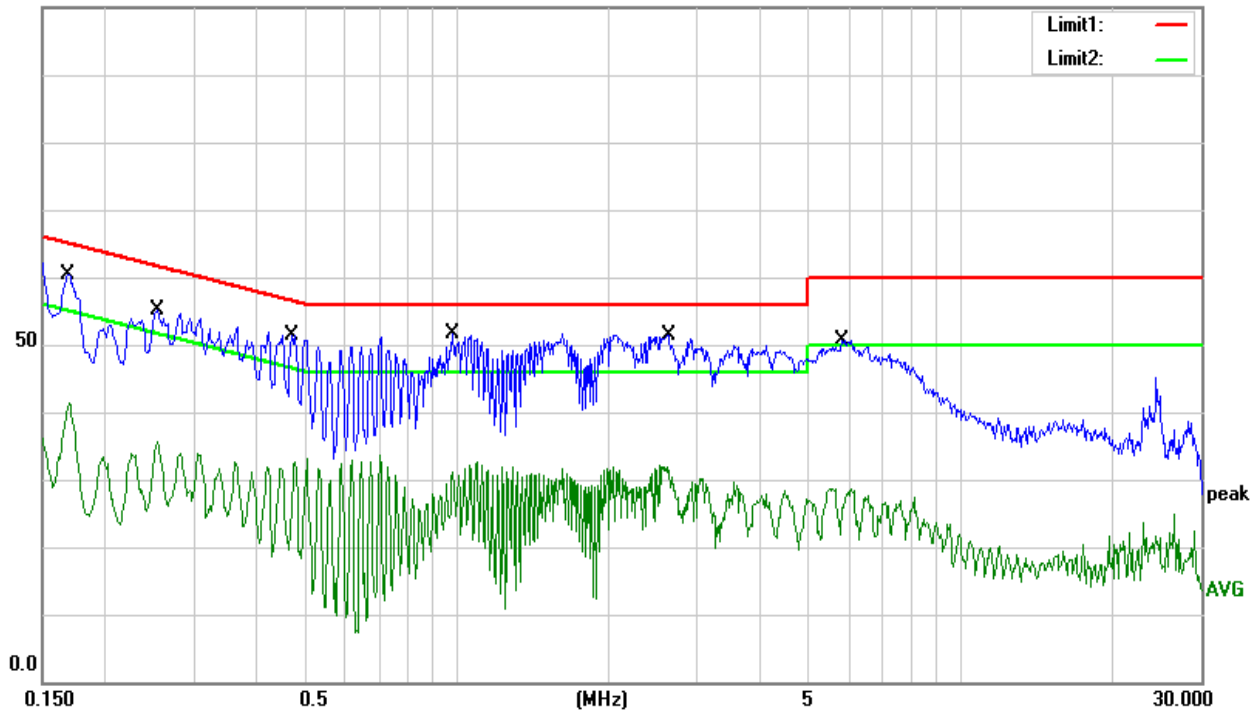



| | | | |
|---------------|-----------------------------------|--------------------|--------|
| Temperature: | 26 °C | Relative Humidity: | 54% |
| Pressure: | 1010hPa | Phase: | N |
| Test Voltage: | DC 5V from Adapter AC120V/60Hz | Test Mode: | Mode 4 |

| Frequency (MHz) | Reading (dBuV) | Correct Factor(dB) | Result (dBuV) | Limit (dBuV) | Margin (dB) | Remark |
|-----------------|----------------|--------------------|---------------|--------------|-------------|--------|
| 0.1700 | 50.95 | 10.00 | 60.95 | 64.96 | -4.01 | QP |
| 0.1700 | 31.78 | 10.00 | 41.78 | 54.96 | -13.18 | AVG |
| 0.3540 | 42.50 | 9.95 | 52.45 | 58.87 | -6.42 | QP |
| 0.3540 | 16.54 | 9.95 | 26.49 | 48.87 | -22.38 | AVG |
| 0.9780 | 40.79 | 10.00 | 50.79 | 56.00 | -5.21 | QP |
| 0.9780 | 20.29 | 10.00 | 30.29 | 46.00 | -15.71 | AVG |
| 2.0740 | 42.79 | 10.00 | 52.79 | 56.00 | -3.21 | QP |
| 2.0740 | 23.05 | 10.00 | 33.05 | 46.00 | -12.95 | AVG |
| 4.1180 | 40.61 | 10.19 | 50.80 | 56.00 | -5.20 | QP |
| 4.1180 | 19.18 | 10.19 | 29.37 | 46.00 | -16.63 | AVG |
| 6.7900 | 38.01 | 10.20 | 48.21 | 60.00 | -11.79 | QP |
| 6.7900 | 12.78 | 10.20 | 22.98 | 50.00 | -27.02 | AVG |

Remark:

1. Factor = Antenna Factor + Cable Loss – Pre-amplifier.

100.0 dBuV

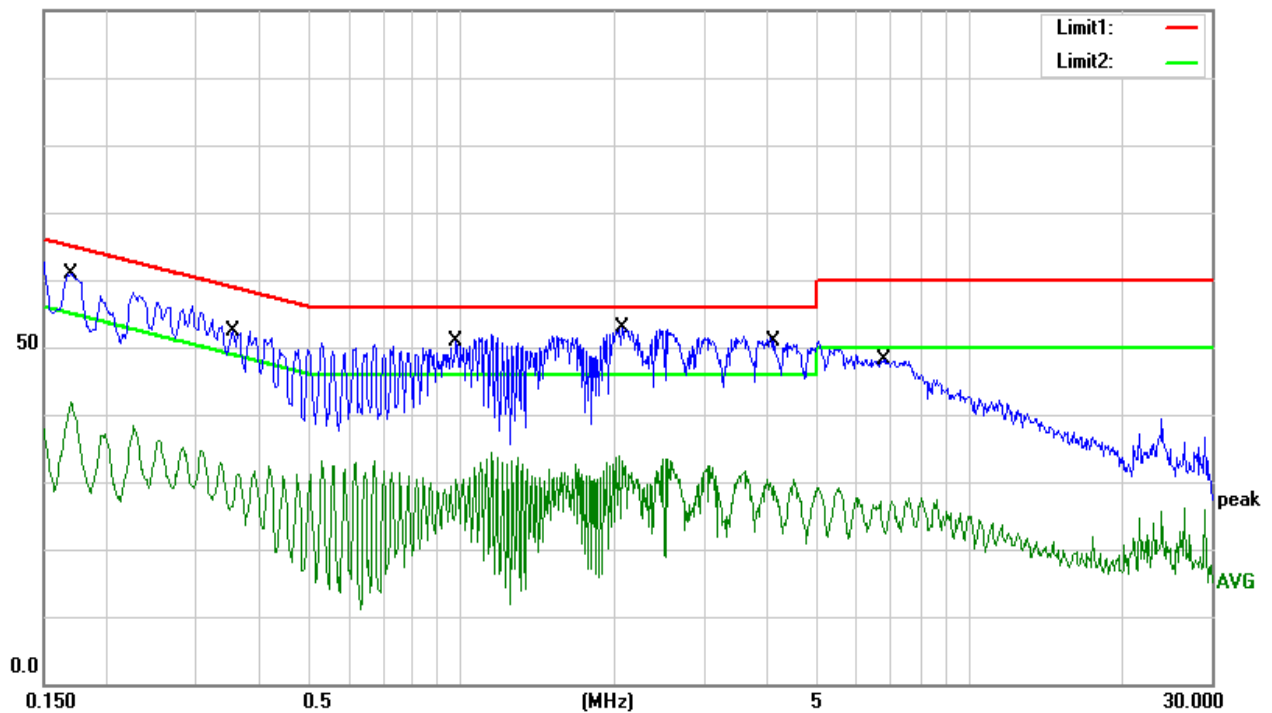



3.2 RADIATED EMISSION MEASUREMENT

3.2.1 RADIATED EMISSION LIMITS

6 dBc in any 100 kHz bandwidth outside the operating frequency band. In case the emission fall within the restricted band specified on Part 15.247&205(a), then the Part 15.247&209(a) limit in the table below has to be followed.

| Frequencies (MHz) | Field Strength (microrvolts/meter) | Measurement Distance (meters) |
|-------------------|------------------------------------|-------------------------------|
| 0.009~0.490 | 2400/F(KHz) | 300 |
| 0.490~1.705 | 24000/F(KHz) | 30 |
| 1.705~30.0 | 30 | 30 |
| 30~88 | 100 | 3 |
| 88~216 | 150 | 3 |
| 216~960 | 200 | 3 |
| Above 960 | 500 | 3 |

LIMITS OF RADIATED EMISSION MEASUREMENT (Above 1000MHz)

| FREQUENCY (MHz) | Class B (dBuV/m) (at 3M) | |
|-----------------|--------------------------|---------|
| | PEAK | AVERAGE |
| Above 1000 | 74 | 54 |

Notes:

- (1) The limit for radiated test was performed according to FCC PART 15C.
- (2) The tighter limit applies at the band edges.
- (3) Emission level (dBuV/m)=20log Emission level (uV/m).

FREQUENCY RANGE OF RADIATED MEASUREMENT (For unintentional radiators)

| Highest frequency generated or Upper frequency of measurement used in the device or on which the device operates or tunes (MHz) | Range (MHz) |
|---|---|
| Below 1.705 | 30 |
| 1.705 – 108 | 1000 |
| 108 – 500 | 2000 |
| 500 – 1000 | 5000 |
| Above 1000 | 5 th harmonic of the highest frequency or 40 GHz, whichever is lower |



| Spectrum Parameter | Setting |
|---------------------------------------|---|
| Attenuation | Auto |
| Detector | Peak |
| Start Frequency | 1000 MHz(Peak/AV) |
| Stop Frequency | 10 th carrier hamonic(Peak/AV) |
| RB / VB (emission in restricted band) | 1 MHz / 1 MHz, AV=3 MHz |

| Receiver Parameter | Setting |
|------------------------|----------------------------------|
| Attenuation | Auto |
| Start ~ Stop Frequency | 9kHz~150kHz / RB 200Hz for QP |
| Start ~ Stop Frequency | 150kHz~30MHz / RB 9kHz for QP |
| Start ~ Stop Frequency | 30MHz~1000MHz / RB 120kHz for QP |

3.2.2 TEST PROCEDURE

- The measuring distance of at 3 m shall be used for measurements at frequency up to 1GHz. For frequencies above 1GHz, any suitable measuring distance may be used.
- The EUT was placed on the top of a rotating table 0.8 meters(above 1GHz is 1.5 m) above the ground at a 3 meter open area test site. The table was rotated 360 degrees to determine the position of the highest radiation.
- The height of the equipment or of the substitution antenna shall be 0.8 m(above 1GHz is 1.5 m); the height of the test antenna shall vary between 1 m to 4 m. Both horizontal and vertical polarizations of the antenna are set to make the measurement.
- The initial step in collecting conducted emission data is a spectrum analyzer peak detector mode pre-scanning the measurement frequency range. Significant peaks are then marked and then Quasi Peak detector mode re-measured.
- If the Peak Mode measured value compliance with and lower than Quasi Peak Mode Limit, the EUT shall be deemed to meet QP Limits and then no additional QP Mode measurement performed.
- For the actual test configuration, please refer to the related Item –EUT Test Photos.

Note:

Both horizontal and vertical antenna polarities were tested and performed pretest to three orthogonal axis. The worst case emissions were reported

3.2.3 TEST SETUP

(A) Radiated Emission Test-Up Frequency Below 30MHz

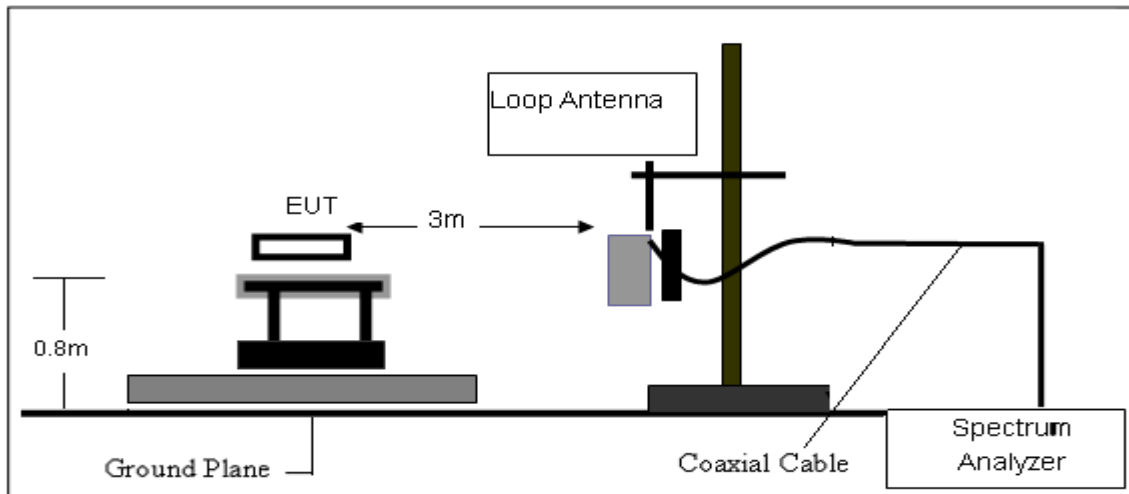

(B) Radiated Emission Test-Up Frequency 30MHz~1GHz

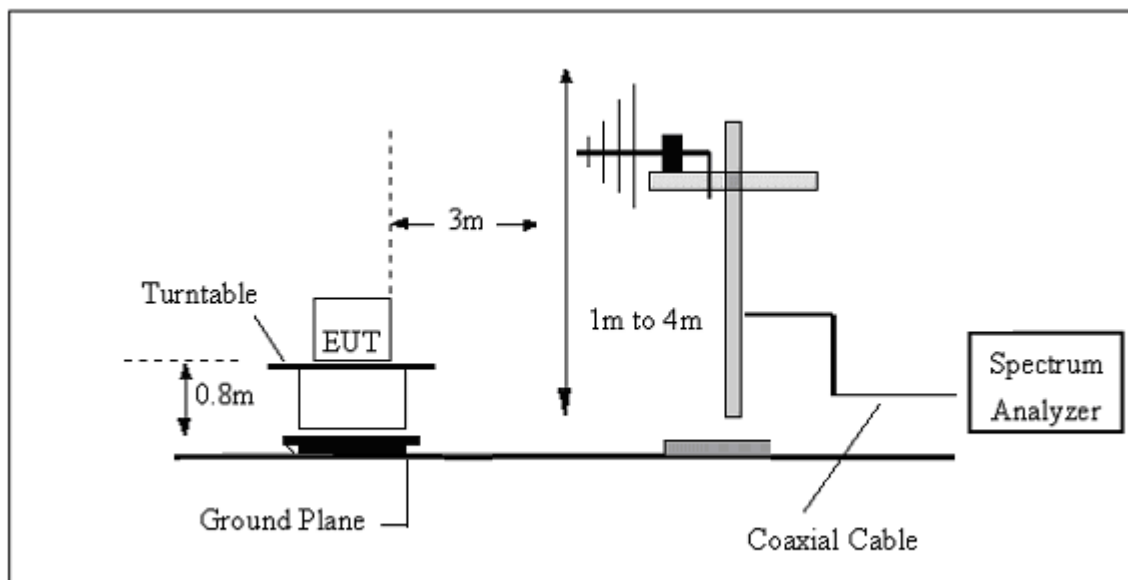

(C) Radiated Emission Test-Up Frequency Above 1GHz

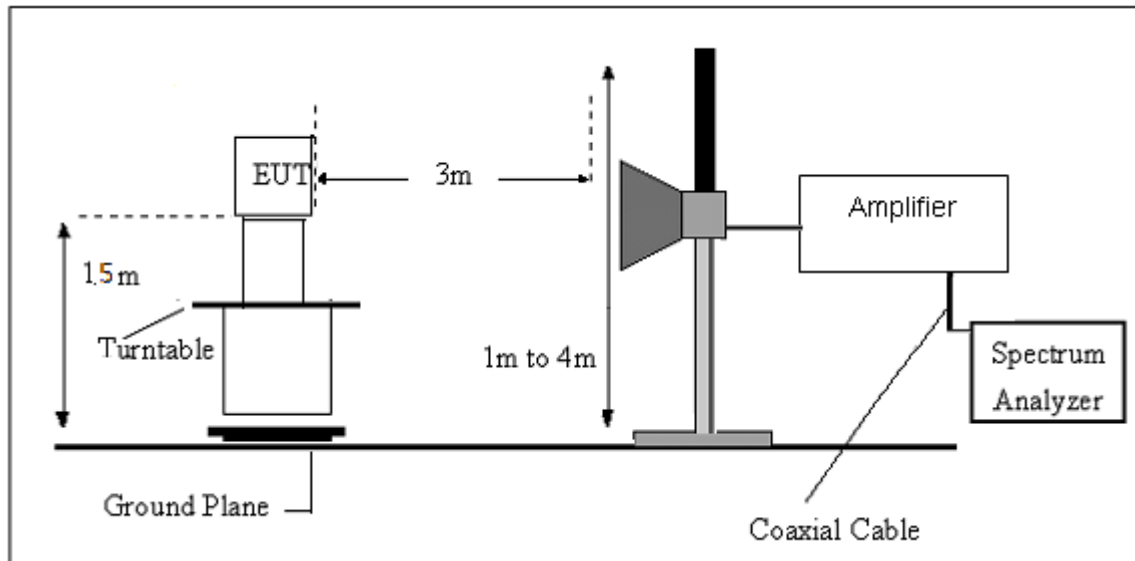

3.2.4 EUT OPERATING CONDITIONS

The EUT tested system was configured as the statements of 2.3 Unless otherwise a special operating condition is specified in the follows during the testing.



3.2.5 TEST RESULT

9KHz-30MHz

| | | | |
|--------------|-----------|--------------------|-----------------------------------|
| Temperature: | 20 °C | Relative Humidity: | 48% |
| Pressure: | 1010 hPa | Test Voltage : | DC 5V from Adapter AC120V/60Hz |
| Test Mode : | Link mode | Polarization : | -- |

| Freq. (MHz) | Reading (dBuV/m) | Limit (dBuV/m) | Margin (dB) | State P/F | Test Result |
|----------------|---------------------|-------------------|----------------|--------------|----------------|
| -- | -- | -- | -- | -- | PASS |
| -- | -- | -- | -- | -- | PASS |

Note:

The amplitude of spurious emissions which are attenuated by more than 20dB below the permissible value has no need to be reported.

Distance extrapolation factor = $40 \log(\text{specific distance}/\text{test distance})$ (dB);

Limit line = specific limits(dBuV) + distance extrapolation factor.



30MHz - 1000MHz

| | | | |
|--------------|----------|--------------------|-----------------------------------|
| Temperature: | 20 °C | Relative Humidity: | 48% |
| Pressure: | 1010 hPa | Test Voltage : | DC 5V from Adapter AC120V/60Hz |
| Test Mode : | Mode 4 | Polarization : | Horizontal |

| Frequency (MHz) | Reading (dBuV) | Correct Factor(dB/m) | Result (dBuV/m) | Limit (dBuV/m) | Margin (dB) | Remark |
|--------------------|-------------------|-------------------------|--------------------|-------------------|----------------|--------|
| 30.2110 | 5.50 | 18.60 | 24.10 | 40.00 | -15.90 | QP |
| 85.2980 | 22.62 | 8.85 | 31.47 | 40.00 | -8.53 | QP |
| 164.9074 | 24.74 | 11.04 | 35.78 | 43.50 | -7.72 | QP |
| 307.8312 | 24.00 | 14.94 | 38.94 | 46.00 | -7.06 | QP |
| 422.0577 | 17.66 | 18.78 | 36.44 | 46.00 | -9.56 | QP |
| 830.4002 | 10.39 | 26.53 | 36.92 | 46.00 | -9.08 | QP |

Remark:

1. Factor = Antenna Factor + Cable Loss – Pre-amplifier.

80.0 dBuV/m

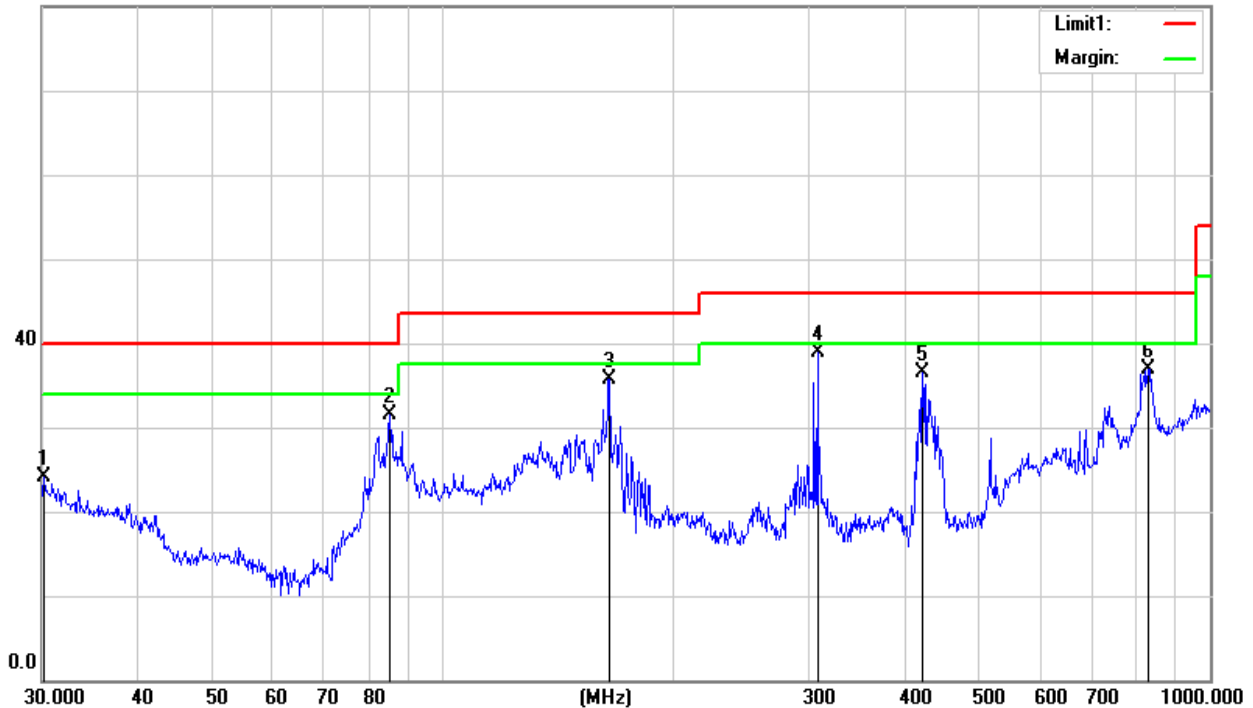



30MHz - 1000MHz

| | | | |
|--------------|----------|--------------------|-----------------------------------|
| Temperature: | 20 °C | Relative Humidity: | 48% |
| Pressure: | 1010 hPa | Test Voltage : | DC 5V from Adapter AC120V/60Hz |
| Test Mode : | Mode 4 | Polarization : | Vertical |

| Frequency (MHz) | Reading (dBuV) | Correct Factor(dB/m) | Result (dBuV/m) | Limit (dBuV/m) | Margin (dB) | Remark |
|--------------------|-------------------|-------------------------|--------------------|-------------------|----------------|--------|
| 39.5756 | 17.76 | 13.69 | 31.45 | 40.00 | -8.55 | QP |
| 82.3590 | 24.70 | 8.32 | 33.02 | 40.00 | -6.98 | QP |
| 164.3301 | 26.63 | 11.11 | 37.74 | 43.50 | -5.76 | QP |
| 304.6100 | 24.16 | 14.83 | 38.99 | 46.00 | -7.01 | QP |
| 423.5403 | 18.96 | 18.77 | 37.73 | 46.00 | -8.27 | QP |
| 827.4933 | 11.05 | 26.23 | 37.28 | 46.00 | -8.72 | QP |

Remark:

1. Factor = Antenna Factor + Cable Loss – Pre-amplifier.

80.0 dBuV/m

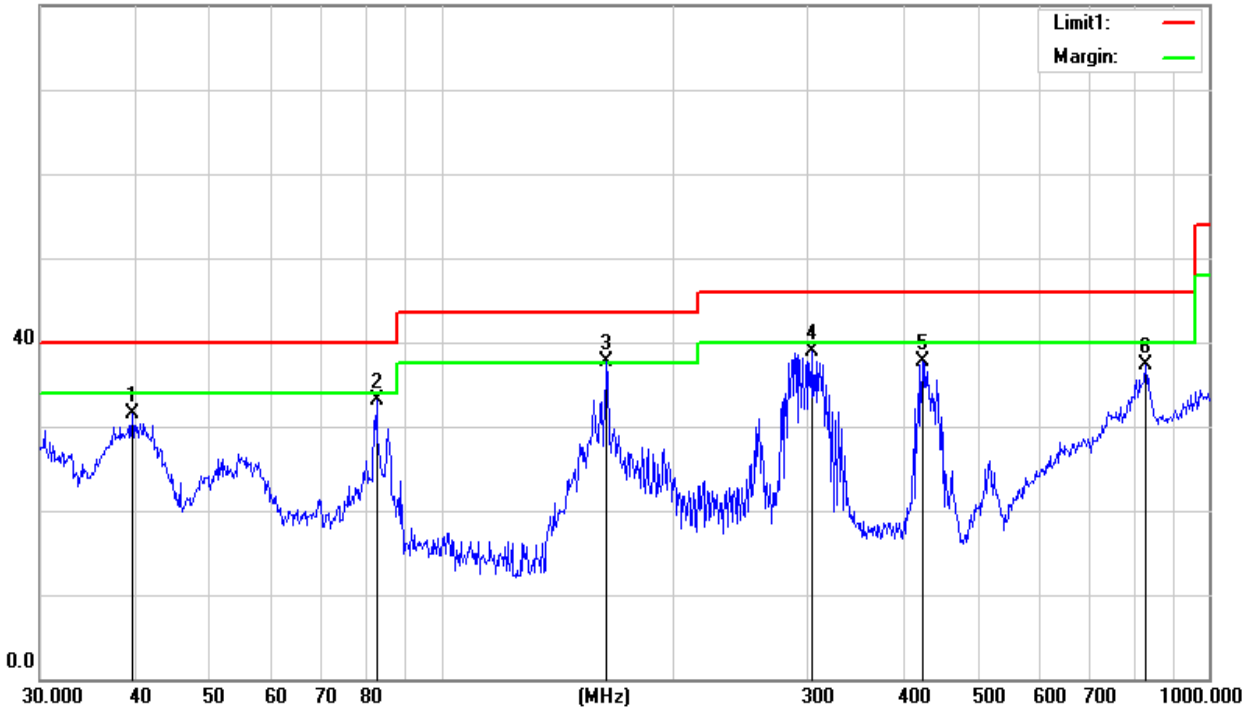



(1000MHz-25GHz)

802.11b Low Channel

| Meter | | Antenna | | Corrected | | Emission | | | | |
|------------------------|---------|-----------|-------|-----------|--------|----------|----------|--------|----------|------------|
| Frequency | Reading | Amplifier | Loss | Factor | Factor | Level | Limits | Margin | Detector | |
| (MHz) | (dBμV) | (dB) | (dB) | (dB/m) | (dB) | (dBμV/m) | (dBμV/m) | (dB) | Type | Comment |
| Low Channel (2412 MHz) | | | | | | | | | | |
| 3265.10 | 49.97 | 44.70 | 6.70 | 28.20 | -9.80 | 40.17 | 74.00 | -33.83 | PK | Vertical |
| 3265.10 | 39.93 | 44.70 | 6.70 | 28.20 | -9.80 | 30.13 | 54.00 | -23.87 | AV | Vertical |
| 3265.06 | 49.94 | 44.70 | 6.70 | 28.20 | -9.80 | 40.14 | 74.00 | -33.86 | PK | Horizontal |
| 3265.06 | 39.94 | 44.70 | 6.70 | 28.20 | -9.80 | 30.14 | 54.00 | -23.86 | AV | Horizontal |
| 4824.78 | 60.26 | 44.20 | 9.04 | 31.60 | -3.56 | 56.70 | 74.00 | -17.30 | PK | Vertical |
| 4824.78 | 50.29 | 44.20 | 9.04 | 31.60 | -3.56 | 46.73 | 54.00 | -7.27 | AV | Vertical |
| 4824.81 | 60.23 | 44.20 | 9.04 | 31.60 | -3.56 | 56.67 | 74.00 | -17.33 | PK | Horizontal |
| 4824.81 | 50.22 | 44.20 | 9.04 | 31.60 | -3.56 | 46.66 | 54.00 | -7.34 | AV | Horizontal |
| 5360.09 | 47.17 | 44.20 | 9.86 | 32.00 | -2.34 | 44.83 | 74.00 | -29.17 | PK | Vertical |
| 5360.09 | 39.13 | 44.20 | 9.86 | 32.00 | -2.34 | 36.79 | 54.00 | -17.21 | AV | Vertical |
| 5360.07 | 47.19 | 44.20 | 9.86 | 32.00 | -2.34 | 44.85 | 74.00 | -29.15 | PK | Horizontal |
| 5360.07 | 39.14 | 44.20 | 9.86 | 32.00 | -2.34 | 36.80 | 54.00 | -17.20 | AV | Horizontal |
| 7236.18 | 52.67 | 43.50 | 11.40 | 35.50 | 3.40 | 56.07 | 74.00 | -17.93 | PK | Vertical |
| 7236.18 | 44.64 | 43.50 | 11.40 | 35.50 | 3.40 | 48.04 | 54.00 | -5.96 | AV | Vertical |
| 7236.16 | 52.62 | 43.50 | 11.40 | 35.50 | 3.40 | 56.02 | 74.00 | -17.98 | PK | Horizontal |
| 7236.16 | 44.62 | 43.50 | 11.40 | 35.50 | 3.40 | 48.02 | 54.00 | -5.98 | AV | Horizontal |
| 11036.22 | 41.92 | 43.60 | 14.30 | 39.50 | 10.20 | 52.12 | 74.00 | -21.88 | PK | Vertical |
| 11036.22 | 31.88 | 43.60 | 14.30 | 39.50 | 10.20 | 42.08 | 54.00 | -11.92 | AV | Vertical |
| 11036.47 | 41.86 | 43.60 | 14.30 | 39.50 | 10.20 | 52.06 | 74.00 | -21.94 | PK | Horizontal |
| 11036.47 | 31.85 | 43.60 | 14.30 | 39.50 | 10.20 | 42.05 | 54.00 | -11.95 | AV | Horizontal |
| 13299.62 | 41.68 | 42.60 | 15.90 | 38.90 | 12.20 | 53.88 | 74.00 | -20.12 | PK | Vertical |
| 13299.62 | 31.76 | 42.60 | 15.90 | 38.90 | 12.20 | 43.96 | 54.00 | -10.04 | AV | Vertical |
| 13299.74 | 41.75 | 42.60 | 15.90 | 38.90 | 12.20 | 53.95 | 74.00 | -20.05 | PK | Horizontal |
| 13299.74 | 30.72 | 42.60 | 15.90 | 38.90 | 12.20 | 42.92 | 54.00 | -11.08 | AV | Horizontal |
| 16000.15 | 41.77 | 42.70 | 18.00 | 37.10 | 12.40 | 54.17 | 74.00 | -19.83 | PK | Vertical |
| 16000.15 | 31.77 | 42.70 | 18.00 | 37.10 | 12.40 | 44.17 | 54.00 | -9.83 | AV | Vertical |
| 16000.04 | 41.77 | 42.70 | 18.00 | 37.10 | 12.40 | 54.17 | 74.00 | -19.83 | PK | Horizontal |
| 16000.04 | 31.02 | 42.70 | 18.00 | 37.10 | 12.40 | 43.42 | 54.00 | -10.58 | AV | Horizontal |
| 17998.14 | 31.90 | 42.70 | 19.40 | 46.50 | 23.20 | 55.10 | 74.00 | -18.90 | PK | Vertical |
| 17998.14 | 21.91 | 42.70 | 19.40 | 46.50 | 23.20 | 45.11 | 54.00 | -8.89 | AV | Vertical |
| 17998.01 | 31.90 | 42.70 | 19.40 | 46.50 | 23.20 | 55.10 | 74.00 | -18.90 | PK | Horizontal |
| 17998.01 | 21.95 | 42.70 | 19.40 | 46.50 | 23.20 | 45.15 | 54.00 | -8.85 | AV | Horizontal |



802.11b Mid Channel

| Frequency (MHz) | Meter | | Loss (dB) | Antenna | | Emission | | Margin (dB) | Detector Type | Comment |
|------------------------|-------------------|-------------------|--------------|------------------|-----------------------------|-------------------|--------------------|----------------|------------------|------------|
| | Reading (dBμV) | Amplifier (dB) | | Factor (dB/m) | Corrected Factor (dB) | Level (dBμV/m) | Limits (dBμV/m) | | | |
| Low Channel (2437 MHz) | | | | | | | | | | |
| 3265.00 | 49.86 | 44.70 | 6.70 | 28.20 | -9.80 | 40.06 | 74.00 | -33.94 | PK | Vertical |
| 3265.00 | 39.83 | 44.70 | 6.70 | 28.20 | -9.80 | 30.03 | 54.00 | -23.97 | AV | Vertical |
| 3264.95 | 49.85 | 44.70 | 6.70 | 28.20 | -9.80 | 40.05 | 74.00 | -33.95 | PK | Horizontal |
| 3264.95 | 39.84 | 44.70 | 6.70 | 28.20 | -9.80 | 30.04 | 54.00 | -23.96 | AV | Horizontal |
| 4874.76 | 60.14 | 44.20 | 9.04 | 31.60 | -3.56 | 56.58 | 74.00 | -17.42 | PK | Vertical |
| 4874.76 | 50.18 | 44.20 | 9.04 | 31.60 | -3.56 | 46.62 | 54.00 | -7.38 | AV | Vertical |
| 4874.70 | 60.17 | 44.20 | 9.04 | 31.60 | -3.56 | 56.61 | 74.00 | -17.39 | PK | Horizontal |
| 4874.70 | 50.14 | 44.20 | 9.04 | 31.60 | -3.56 | 46.58 | 54.00 | -7.42 | AV | Horizontal |
| 5359.97 | 47.06 | 44.20 | 9.86 | 32.00 | -2.34 | 44.72 | 74.00 | -29.28 | PK | Vertical |
| 5359.97 | 39.07 | 44.20 | 9.86 | 32.00 | -2.34 | 36.73 | 54.00 | -17.27 | AV | Vertical |
| 5360.00 | 47.12 | 44.20 | 9.86 | 32.00 | -2.34 | 44.78 | 74.00 | -29.22 | PK | Horizontal |
| 5360.00 | 39.03 | 44.20 | 9.86 | 32.00 | -2.34 | 36.69 | 54.00 | -17.31 | AV | Horizontal |
| 7336.05 | 52.56 | 43.50 | 11.40 | 35.50 | 3.40 | 55.96 | 74.00 | -18.04 | PK | Vertical |
| 7336.05 | 44.54 | 43.50 | 11.40 | 35.50 | 3.40 | 47.94 | 54.00 | -6.06 | AV | Vertical |
| 7336.04 | 52.57 | 43.50 | 11.40 | 35.50 | 3.40 | 55.97 | 74.00 | -18.03 | PK | Horizontal |
| 7336.04 | 44.55 | 43.50 | 11.40 | 35.50 | 3.40 | 47.95 | 54.00 | -6.05 | AV | Horizontal |
| 11036.11 | 41.83 | 43.60 | 14.30 | 39.50 | 10.20 | 52.03 | 74.00 | -21.97 | PK | Vertical |
| 11036.11 | 31.80 | 43.60 | 14.30 | 39.50 | 10.20 | 42.00 | 54.00 | -12.00 | AV | Vertical |
| 11036.11 | 41.83 | 43.60 | 14.30 | 39.50 | 10.20 | 52.03 | 74.00 | -21.97 | PK | Horizontal |
| 11036.11 | 31.83 | 43.60 | 14.30 | 39.50 | 10.20 | 42.03 | 54.00 | -11.97 | AV | Horizontal |
| 13299.71 | 41.62 | 42.60 | 15.90 | 38.90 | 12.20 | 53.82 | 74.00 | -20.18 | PK | Vertical |
| 13299.71 | 31.66 | 42.60 | 15.90 | 38.90 | 12.20 | 43.86 | 54.00 | -10.14 | AV | Vertical |
| 13299.62 | 41.71 | 42.60 | 15.90 | 38.90 | 12.20 | 53.91 | 74.00 | -20.09 | PK | Horizontal |
| 13299.62 | 30.65 | 42.60 | 15.90 | 38.90 | 12.20 | 42.85 | 54.00 | -11.15 | AV | Horizontal |
| 15999.98 | 41.70 | 42.70 | 18.00 | 37.10 | 12.40 | 54.10 | 74.00 | -19.90 | PK | Vertical |
| 15999.98 | 31.65 | 42.70 | 18.00 | 37.10 | 12.40 | 44.05 | 54.00 | -9.95 | AV | Vertical |
| 15999.99 | 41.70 | 42.70 | 18.00 | 37.10 | 12.40 | 54.10 | 74.00 | -19.90 | PK | Horizontal |
| 15999.99 | 30.97 | 42.70 | 18.00 | 37.10 | 12.40 | 43.37 | 54.00 | -10.63 | AV | Horizontal |
| 17998.13 | 31.84 | 42.70 | 19.40 | 46.50 | 23.20 | 55.04 | 74.00 | -18.96 | PK | Vertical |
| 17998.13 | 21.85 | 42.70 | 19.40 | 46.50 | 23.20 | 45.05 | 54.00 | -8.95 | AV | Vertical |
| 17998.00 | 31.86 | 42.70 | 19.40 | 46.50 | 23.20 | 55.06 | 74.00 | -18.94 | PK | Horizontal |
| 17998.00 | 21.85 | 42.70 | 19.40 | 46.50 | 23.20 | 45.05 | 54.00 | -8.95 | AV | Horizontal |



802.11b High Channel

| Meter | | Antenna | | Orrected | Emission | | | | | |
|------------------------|---------|-----------|-------|----------|----------|----------|----------|--------|----------|------------|
| Frequency | Reading | Amplifier | Loss | Factor | Factor | Level | Limits | Margin | Detector | |
| (MHz) | (dBμV) | (dB) | (dB) | (dB/m) | (dB) | (dBμV/m) | (dBμV/m) | (dB) | Type | Comment |
| Low Channel (2462 MHz) | | | | | | | | | | |
| 3265.07 | 49.88 | 44.70 | 6.70 | 28.20 | -9.80 | 40.08 | 74.00 | -33.92 | PK | Vertical |
| 3265.07 | 39.83 | 44.70 | 6.70 | 28.20 | -9.80 | 30.03 | 54.00 | -23.97 | AV | Vertical |
| 3265.04 | 49.81 | 44.70 | 6.70 | 28.20 | -9.80 | 40.01 | 74.00 | -33.99 | PK | Horizontal |
| 3265.04 | 39.88 | 44.70 | 6.70 | 28.20 | -9.80 | 30.08 | 54.00 | -23.92 | AV | Horizontal |
| 4924.82 | 60.14 | 44.20 | 9.04 | 31.60 | -3.56 | 56.58 | 74.00 | -17.42 | PK | Vertical |
| 4924.82 | 50.19 | 44.20 | 9.04 | 31.60 | -3.56 | 46.63 | 54.00 | -7.37 | AV | Vertical |
| 4924.78 | 60.19 | 44.20 | 9.04 | 31.60 | -3.56 | 56.63 | 74.00 | -17.37 | PK | Horizontal |
| 4924.78 | 50.12 | 44.20 | 9.04 | 31.60 | -3.56 | 46.56 | 54.00 | -7.44 | AV | Horizontal |
| 5360.04 | 47.06 | 44.20 | 9.86 | 32.00 | -2.34 | 44.72 | 74.00 | -29.28 | PK | Vertical |
| 5360.04 | 39.07 | 44.20 | 9.86 | 32.00 | -2.34 | 36.73 | 54.00 | -17.27 | AV | Vertical |
| 5360.03 | 47.13 | 44.20 | 9.86 | 32.00 | -2.34 | 44.79 | 74.00 | -29.21 | PK | Horizontal |
| 5360.03 | 39.06 | 44.20 | 9.86 | 32.00 | -2.34 | 36.72 | 54.00 | -17.28 | AV | Horizontal |
| 7386.16 | 52.54 | 43.50 | 11.40 | 35.50 | 3.40 | 55.94 | 74.00 | -18.06 | PK | Vertical |
| 7386.16 | 44.55 | 43.50 | 11.40 | 35.50 | 3.40 | 47.95 | 54.00 | -6.05 | AV | Vertical |
| 7386.20 | 52.60 | 43.50 | 11.40 | 35.50 | 3.40 | 56.00 | 74.00 | -18.00 | PK | Horizontal |
| 7386.20 | 44.53 | 43.50 | 11.40 | 35.50 | 3.40 | 47.93 | 54.00 | -6.07 | AV | Horizontal |
| 11036.21 | 41.84 | 43.60 | 14.30 | 39.50 | 10.20 | 52.04 | 74.00 | -21.96 | PK | Vertical |
| 11036.21 | 31.80 | 43.60 | 14.30 | 39.50 | 10.20 | 42.00 | 54.00 | -12.00 | AV | Vertical |
| 11036.19 | 41.83 | 43.60 | 14.30 | 39.50 | 10.20 | 52.03 | 74.00 | -21.97 | PK | Horizontal |
| 11036.19 | 31.84 | 43.60 | 14.30 | 39.50 | 10.20 | 42.04 | 54.00 | -11.96 | AV | Horizontal |
| 16000.09 | 41.68 | 42.70 | 18.00 | 37.10 | 12.40 | 54.08 | 74.00 | -19.92 | PK | Vertical |
| 16000.09 | 31.68 | 42.70 | 18.00 | 37.10 | 12.40 | 44.08 | 54.00 | -9.92 | AV | Vertical |
| 16000.05 | 41.68 | 42.70 | 18.00 | 37.10 | 12.40 | 54.08 | 74.00 | -19.92 | PK | Horizontal |
| 16000.05 | 30.97 | 42.70 | 18.00 | 37.10 | 12.40 | 43.37 | 54.00 | -10.63 | AV | Horizontal |
| 17998.22 | 31.80 | 42.70 | 19.40 | 46.50 | 23.20 | 55.00 | 74.00 | -19.00 | PK | Vertical |
| 17998.22 | 21.85 | 42.70 | 19.40 | 46.50 | 23.20 | 45.05 | 54.00 | -8.95 | AV | Vertical |
| 17998.09 | 31.84 | 42.70 | 19.40 | 46.50 | 23.20 | 55.04 | 74.00 | -18.96 | PK | Horizontal |
| 17998.09 | 21.86 | 42.70 | 19.40 | 46.50 | 23.20 | 45.06 | 54.00 | -8.94 | AV | Horizontal |

Remark:

- Factor = Antenna Factor + Cable Loss – Pre-amplifier.
- Scan with 802.11b, 802.11g, 802.11n (HT-20), 802.11n (HT-40) the worst case is 802.11b.
 Emission Level = Meter Reading + Factor
 Margin = Limit - Emission Leve
- The frequency emission of peak points that did not show above the forms are at least 20dB below the limit, the frequency emission is mainly from the environment noise.



3.2.6 TEST RESULTS (Band edge)

| Frequency (MHz) | Meter | | Loss (dB) | Antenna | | Emission | | Margin (dB) | Detector | |
|--------------------|-------------------|-------------------|--------------|------------------|-----------------------------|-------------------|--------------------|----------------|----------|------------|
| | Reading (dBμV) | Amplifier (dB) | | Factor (dB/m) | Corrected Factor (dB) | Level (dBμV/m) | Limits (dBμV/m) | | Type | Comment |
| 802.11b | | | | | | | | | | |
| 2400.00 | 69.17 | 43.80 | 4.91 | 25.90 | -12.99 | 56.18 | 74 | -17.82 | PK | Vertical |
| 2400.00 | 54.97 | 43.80 | 4.91 | 25.90 | -12.99 | 41.98 | 54 | -12.02 | AV | Vertical |
| 2400.00 | 70.20 | 43.80 | 4.91 | 25.90 | -12.99 | 57.21 | 74 | -16.79 | PK | Horizontal |
| 2400.00 | 54.16 | 43.80 | 4.91 | 25.90 | -12.99 | 41.17 | 54 | -12.83 | AV | Horizontal |
| 2483.50 | 71.03 | 43.80 | 5.12 | 25.90 | -12.78 | 58.25 | 74 | -15.75 | PK | Vertical |
| 2483.50 | 54.03 | 43.80 | 5.12 | 25.90 | -12.78 | 41.25 | 54 | -12.75 | AV | Vertical |
| 2483.50 | 71.12 | 43.80 | 5.12 | 25.90 | -12.78 | 58.34 | 74 | -15.66 | PK | Horizontal |
| 2483.50 | 54.09 | 43.80 | 5.12 | 25.90 | -12.78 | 41.31 | 54 | -12.69 | AV | Horizontal |
| 802.11g | | | | | | | | | | |
| 2400.00 | 67.95 | 43.80 | 4.91 | 25.90 | -12.99 | 54.96 | 74 | -19.04 | PK | Vertical |
| 2400.00 | 54.08 | 43.80 | 4.91 | 25.90 | -12.99 | 41.09 | 54 | -12.91 | AV | Vertical |
| 2400.00 | 67.15 | 43.80 | 4.91 | 25.90 | -12.99 | 54.16 | 74 | -19.84 | PK | Horizontal |
| 2400.00 | 54.98 | 43.80 | 4.91 | 25.90 | -12.99 | 41.99 | 54 | -12.01 | AV | Horizontal |
| 2483.50 | 67.07 | 43.80 | 5.12 | 25.90 | -12.78 | 54.29 | 74 | -19.71 | PK | Vertical |
| 2483.50 | 54.25 | 43.80 | 5.12 | 25.90 | -12.78 | 41.47 | 54 | -12.53 | AV | Vertical |
| 2483.50 | 67.05 | 43.80 | 5.12 | 25.90 | -12.78 | 54.27 | 74 | -19.73 | PK | Horizontal |
| 2483.50 | 54.14 | 43.80 | 5.12 | 25.90 | -12.78 | 41.36 | 54 | -12.64 | AV | Horizontal |
| 802.11n20 | | | | | | | | | | |
| 2400.00 | 67.10 | 43.80 | 4.91 | 25.90 | -12.99 | 54.11 | 74 | -19.89 | PK | Vertical |
| 2400.00 | 54.06 | 43.80 | 4.91 | 25.90 | -12.99 | 41.07 | 54 | -12.93 | AV | Vertical |
| 2400.00 | 67.06 | 43.80 | 4.91 | 25.90 | -12.99 | 54.07 | 74 | -19.93 | PK | Horizontal |
| 2400.00 | 54.11 | 43.80 | 4.91 | 25.90 | -12.99 | 41.12 | 54 | -12.88 | AV | Horizontal |
| 2483.50 | 67.18 | 43.80 | 5.12 | 25.90 | -12.78 | 54.40 | 74 | -19.60 | PK | Vertical |
| 2483.50 | 54.08 | 43.80 | 5.12 | 25.90 | -12.78 | 41.30 | 54 | -12.70 | AV | Vertical |
| 2483.50 | 67.04 | 43.80 | 5.12 | 25.90 | -12.78 | 54.26 | 74 | -19.74 | PK | Horizontal |
| 2483.50 | 54.01 | 43.80 | 5.12 | 25.90 | -12.78 | 41.23 | 54 | -12.77 | AV | Horizontal |



| Frequency (MHz) | Meter | | | Antenna Factor (dB/m) | Orrected Factor (dB) | Emission | | | | Detector Type | Comment |
|---|-------------------|-------------------|--------------|-----------------------------|----------------------------|-------------------|--------------------|----------------|----|------------------|---------|
| | Reading (dBμV) | Amplifier (dB) | Loss (dB) | | | Level (dBμV/m) | Limits (dBμV/m) | Margin (dB) | | | |
| 802.11n40 | | | | | | | | | | | |
| 2400.00 | 65.03 | 43.80 | 4.91 | 25.90 | -12.99 | 52.04 | 74 | -21.96 | PK | Vertical | |
| 2400.00 | 52.99 | 43.80 | 4.91 | 25.90 | -12.99 | 40.00 | 54 | -14.00 | AV | Vertical | |
| 2400.00 | 64.95 | 43.80 | 4.91 | 25.90 | -12.99 | 51.96 | 74 | -22.04 | PK | Horizontal | |
| 2400.00 | 52.05 | 43.80 | 4.91 | 25.90 | -12.99 | 39.06 | 54 | -14.94 | AV | Horizontal | |
| 2483.50 | 64.09 | 43.80 | 5.12 | 25.90 | -12.78 | 51.31 | 74 | -22.69 | PK | Vertical | |
| 2483.50 | 52.01 | 43.80 | 5.12 | 25.90 | -12.78 | 39.23 | 54 | -14.77 | AV | Vertical | |
| 2483.50 | 64.96 | 43.80 | 5.12 | 25.90 | -12.78 | 52.18 | 74 | -21.82 | PK | Horizontal | |
| 2483.50 | 52.96 | 43.80 | 5.12 | 25.90 | -12.78 | 40.18 | 54 | -13.82 | AV | Horizontal | |
| <p>Remark: Factor = Antenna Factor + Cable Loss – Pre-amplifier. Low measurement frequencies is range from 2310 to 2400 MHz, high measurement frequencies is range from 2483.5 to 2500 MHz. Only show the worst point data of the emissions in the frequency 2310-2400 MHz and 2483.5-2500 MHz.</p> | | | | | | | | | | | |

4. CONDUCTED SPURIOUS EMISSIONS

4.1 APPLIED PROCEDURES / LIMIT

In any 100 kHz bandwidth outside the frequency band in which the spread spectrum or digitally modulated intentional radiator is operating, the radio frequency power that is produced by the intentional radiator shall be at least 20 dB below that in the 100 kHz bandwidth within the band that contains the highest level of the desired power, based on either an RF conducted or a radiated measurement. Attenuation below the general limits specified in Section 15.209(a) is not required. In addition, radiated emissions which fall in the restricted bands, as defined in §15.205(a), must also comply with the radiated emission limits specified in §15.209(a) (see §15.205(c)).

4.2 TEST PROCEDURE

| Spectrum Parameter | Setting |
|---------------------------------------|---------------------------------|
| Detector | Peak |
| Start/Stop Frequency | 30 MHz to 10th carrier harmonic |
| RB / VB (emission in restricted band) | 100 KHz/300 KHz |
| Trace-Mode: | Max hold |

For Band edge

| Spectrum Parameter | Setting |
|---------------------------------------|--|
| Detector | Peak |
| Start/Stop Frequency | Lower Band Edge: 2300 to 2430 MHz Upper Band Edge: 2450 to 2500 MHz |
| RB / VB (emission in restricted band) | 100 KHz/300 KHz |
| Trace-Mode: | Max hold |

4.3 DEVIATION FROM STANDARD

No deviation.

4.4 TEST SETUP

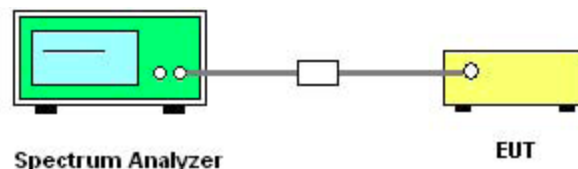

The EUT which is powered by the Battery, is coupled to the Spectrum Analyzer; the RF load attached to the EUT antenna terminal is 50Ohm; the path loss as the factor is calibrated to correct the reading. Make the measurement with the spectrum analyzer's resolution bandwidth (RBW) = 100 kHz. In order to make an accurate measurement, set the span greater than RBW.

4.5 EUT OPERATION CONDITIONS

The EUT tested system was configured as the statements of 2.3 Unless otherwise a special operating condition is specified in the follows during the testing.



4.6 TEST RESULTS

| | | | |
|---------------|-----------------------------|---------------------|---------|
| Temperature : | 25 °C | Relative Humidity : | 60% |
| Pressure : | 1015 hPa | Test Voltage : | DC 3.7V |
| Test Mode : | TX b Mode /CH01, CH06, CH11 | | |

CH 01

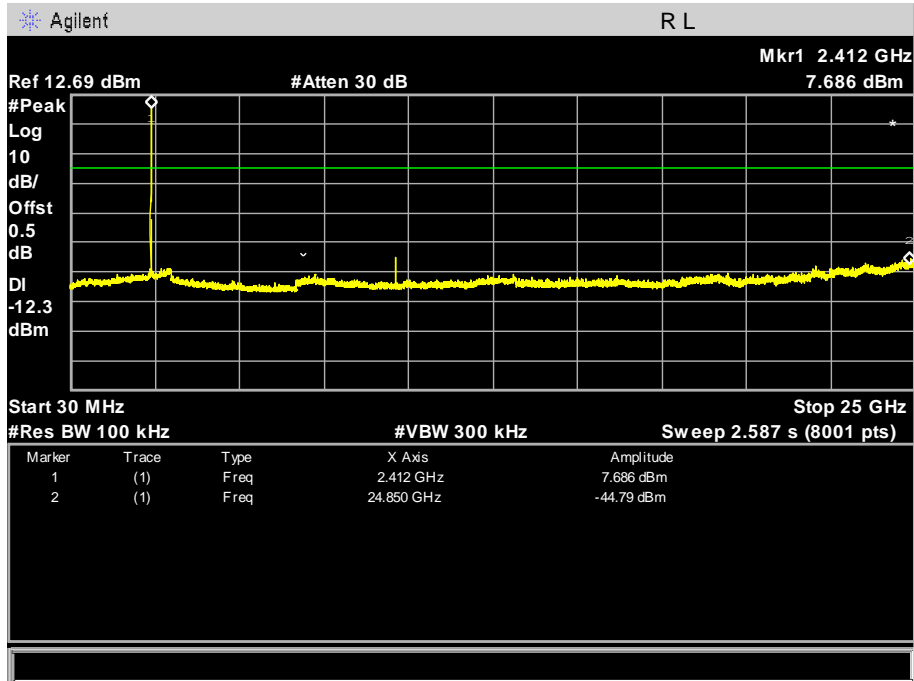



CH 06

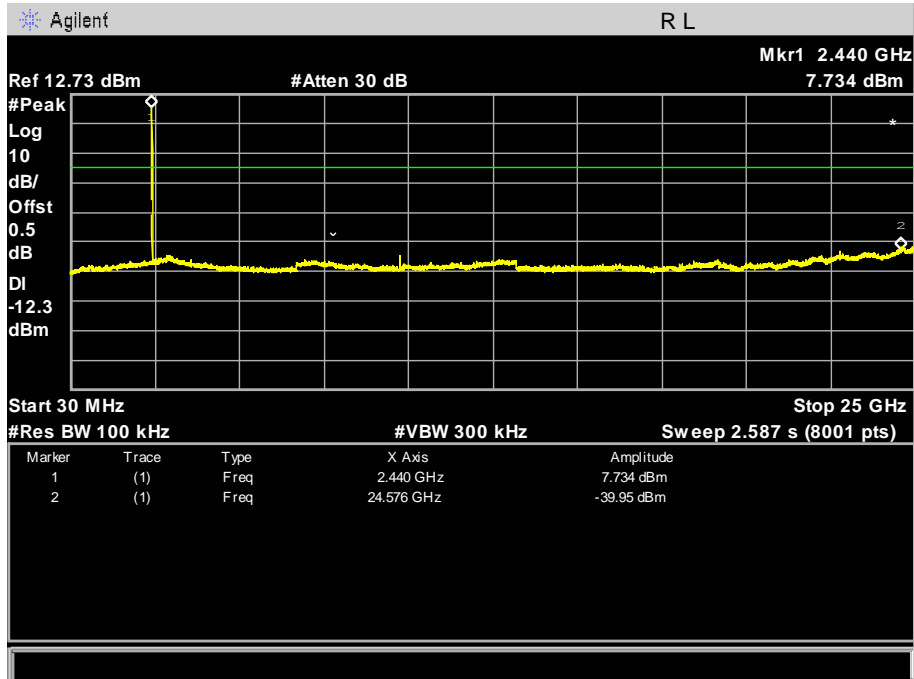

CH 11

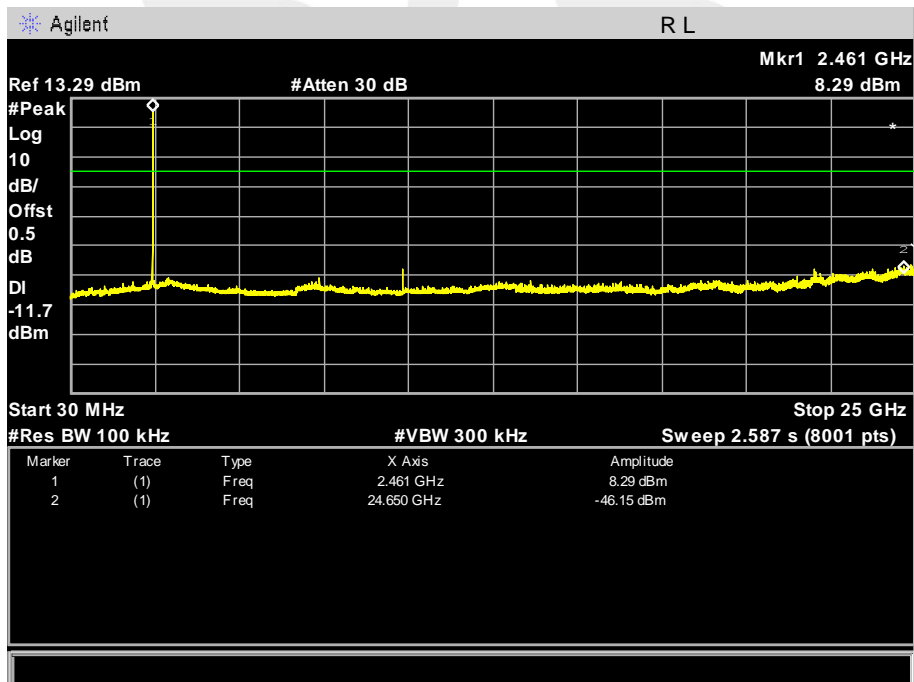



Band edge

CH 01

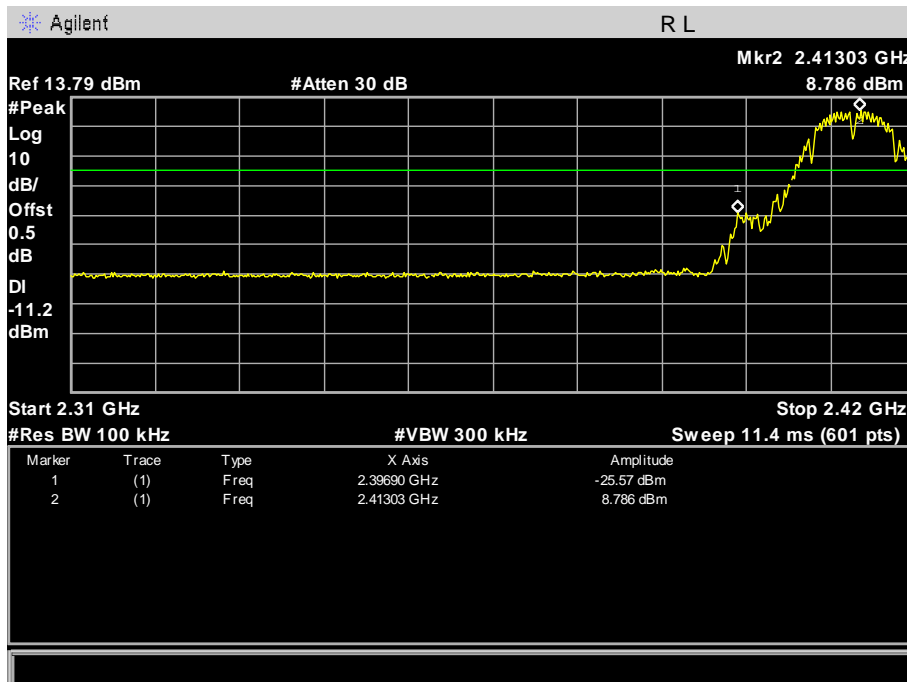

CH 11

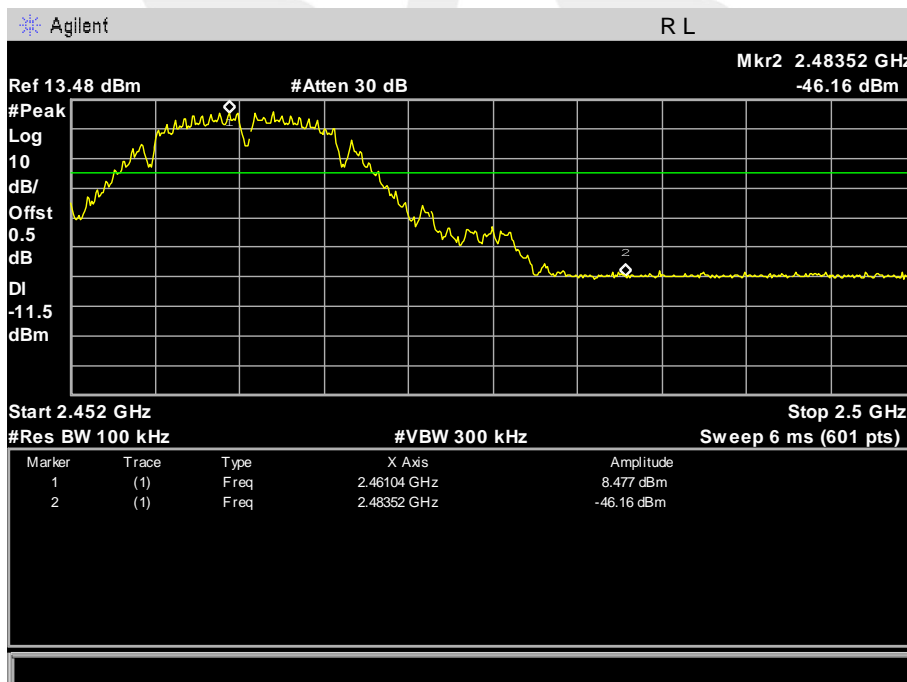



| | | | |
|---------------|-----------------------------|---------------------|---------|
| Temperature : | 25 °C | Relative Humidity : | 60% |
| Pressure : | 1015 hPa | Test Voltage : | DC 3.7V |
| Test Mode : | TX g Mode /CH01, CH06, CH11 | | |

CH 01

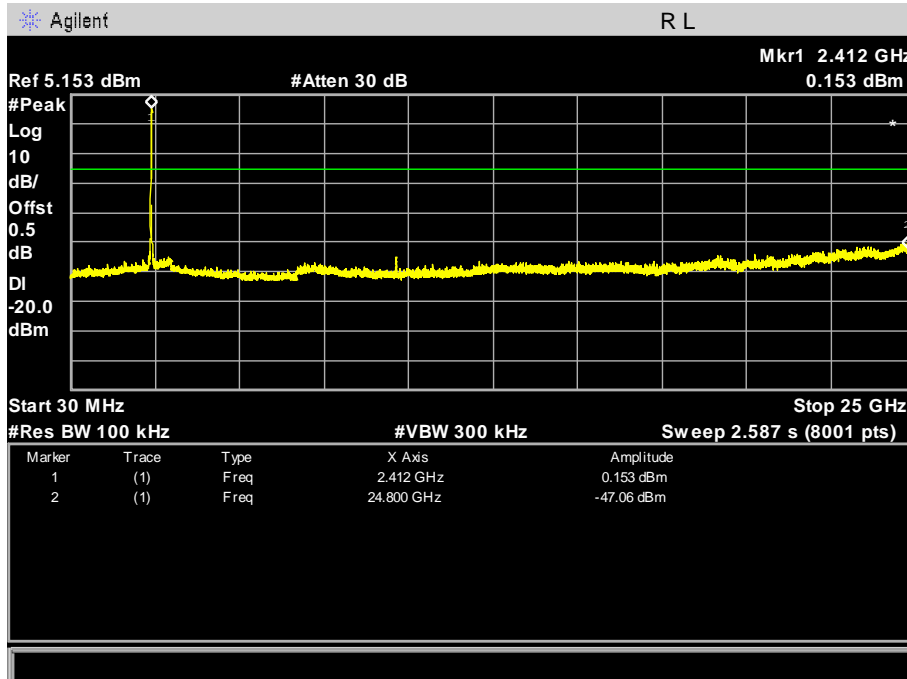

CH06

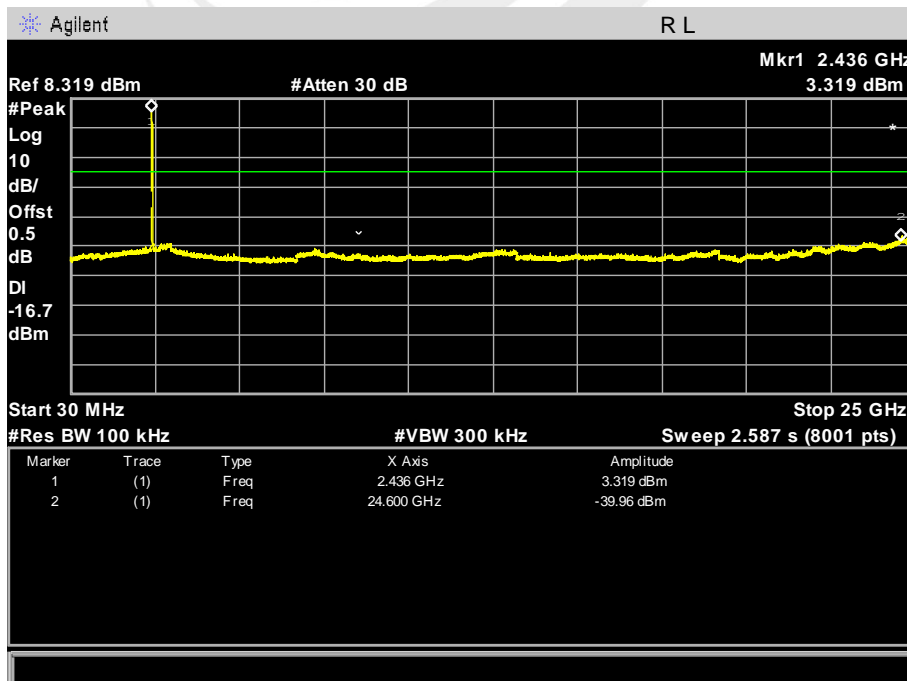



CH 11

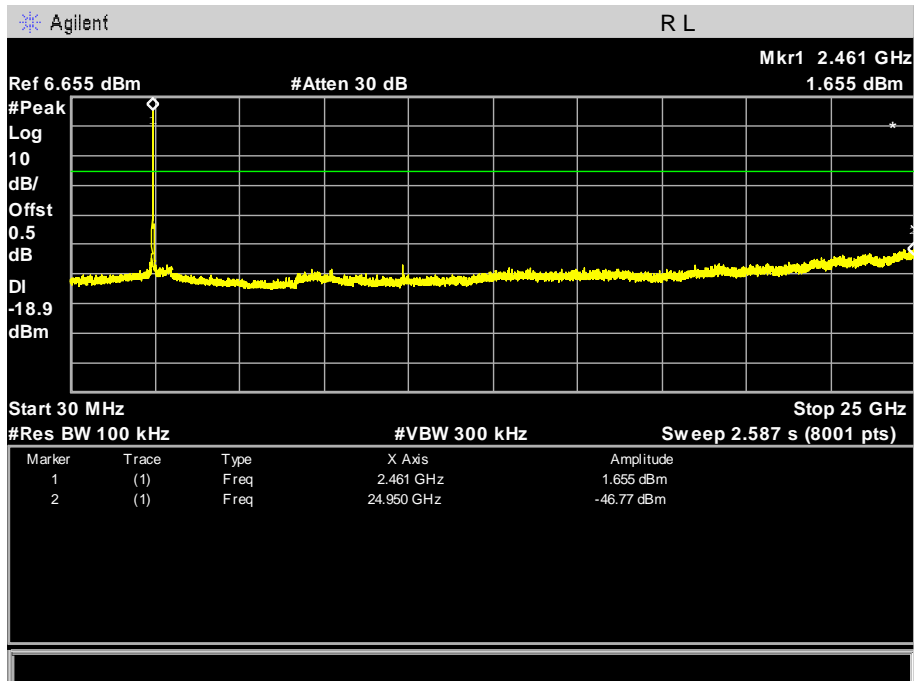



Band edge

CH 01

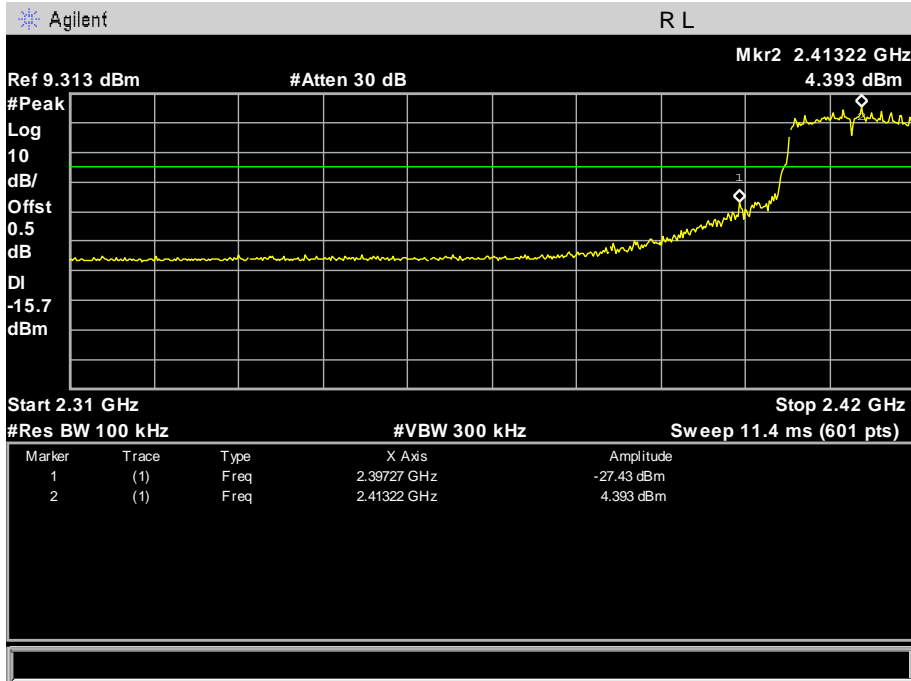

CH11

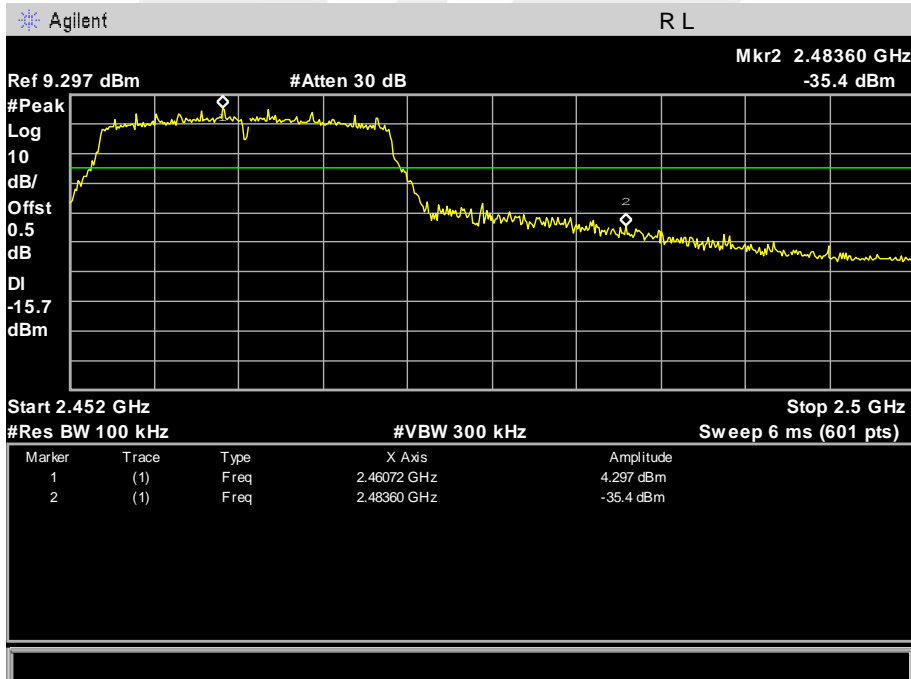



| | | | |
|---------------|----------------------------------|---------------------|---------|
| Temperature : | 25 °C | Relative Humidity : | 60% |
| Pressure : | 1015 hPa | Test Voltage : | DC 3.7V |
| Test Mode : | TX n Mode(20M) /CH01, CH06, CH11 | | |

CH 01

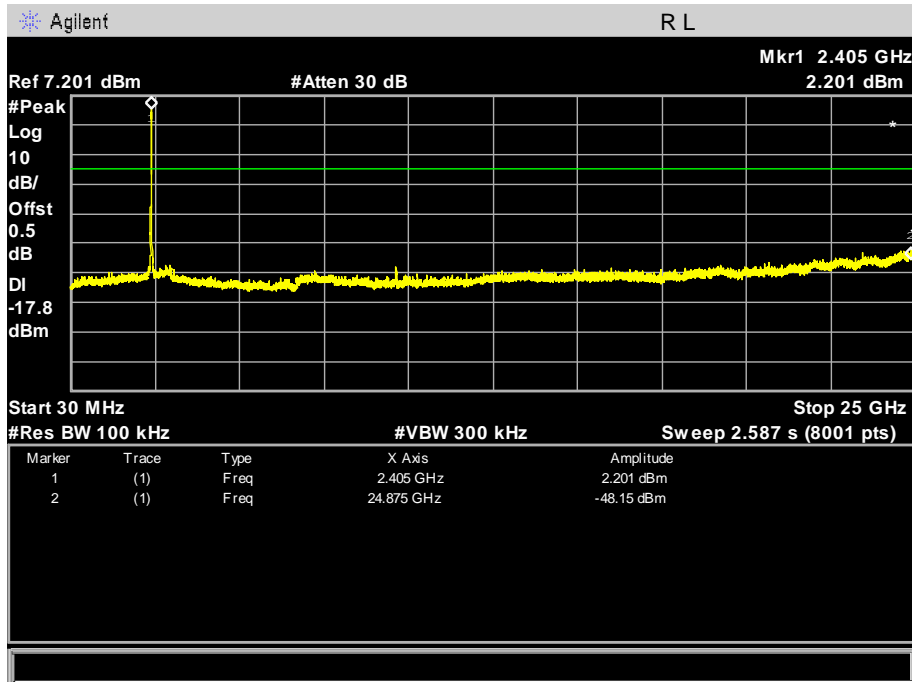

CH 06

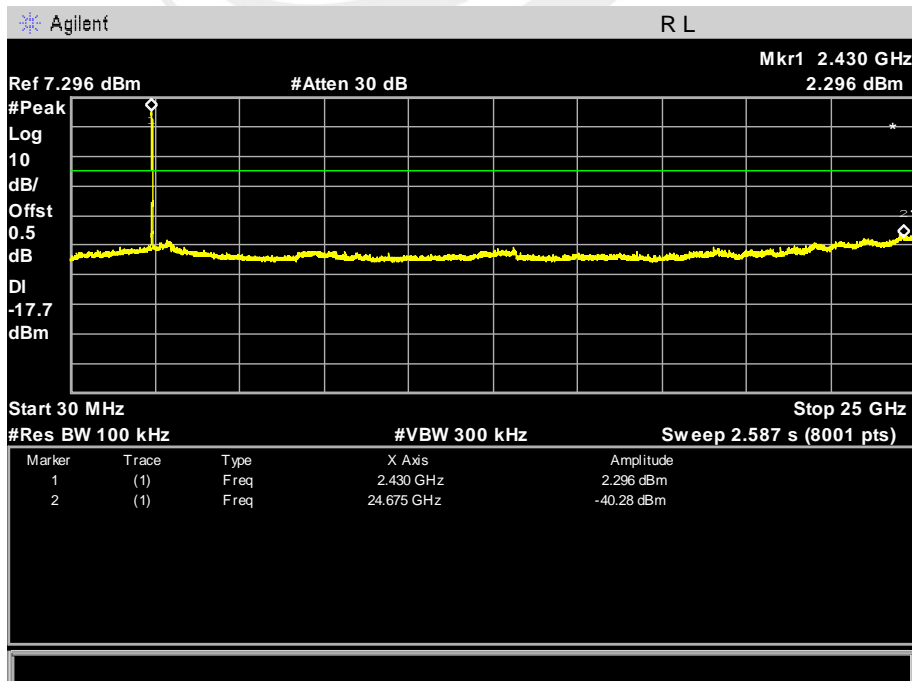



CH 11

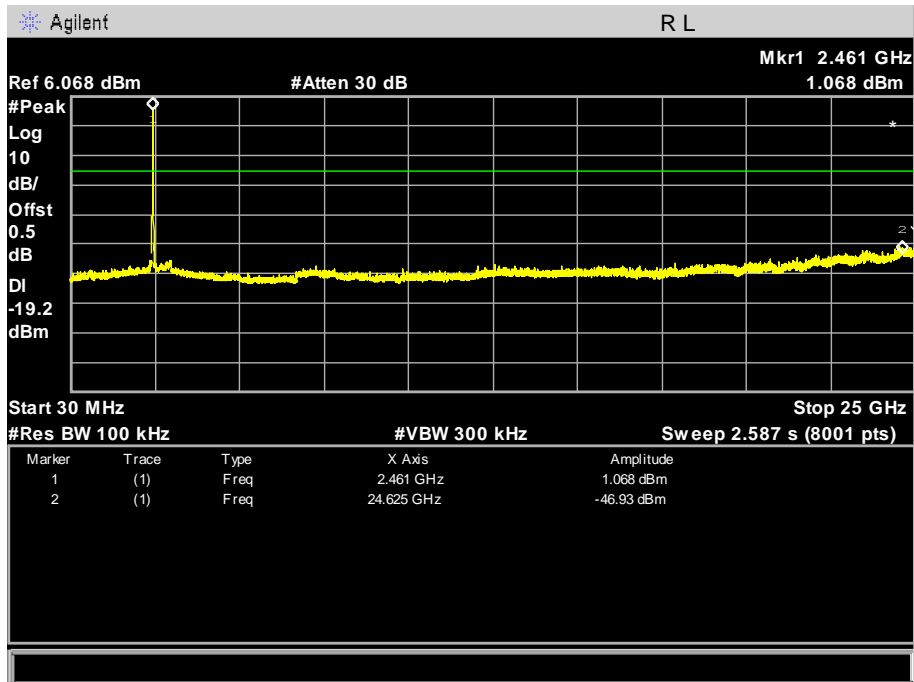



Band edge

CH 01

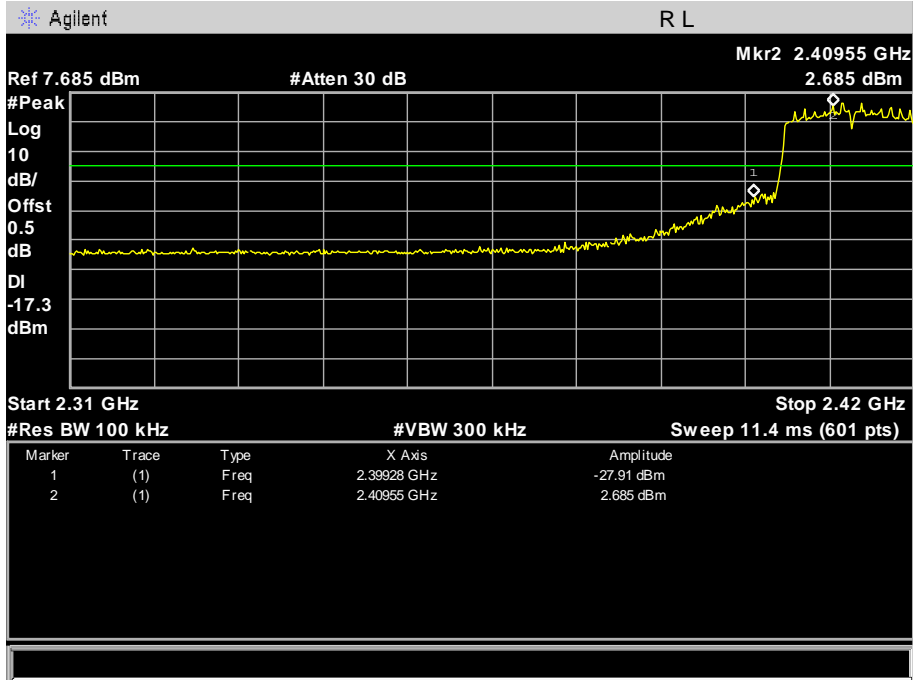

CH 11

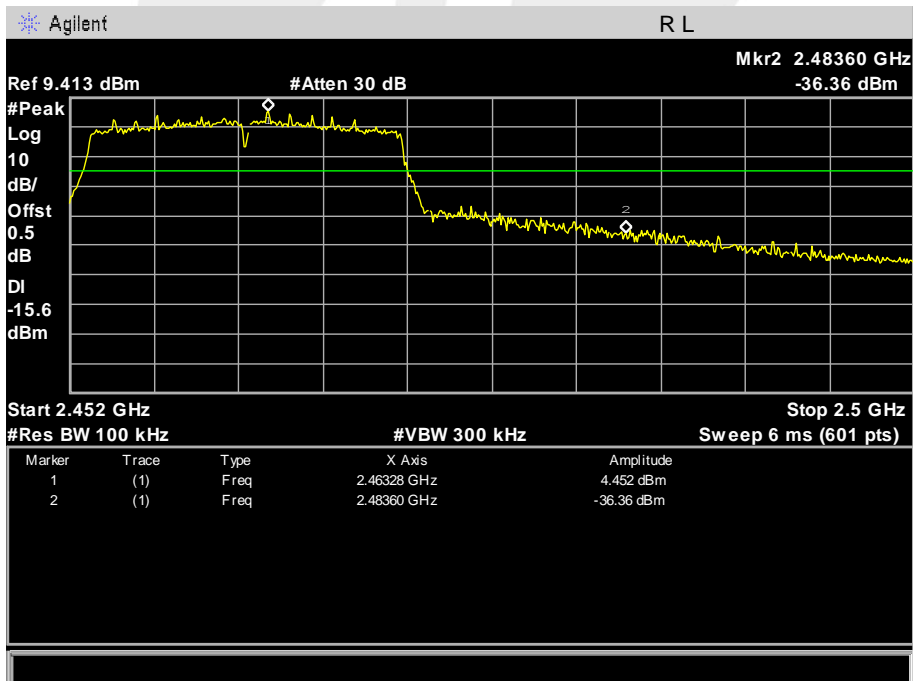



| | | | |
|---------------|----------------------------------|---------------------|---------|
| Temperature : | 25 °C | Relative Humidity : | 60% |
| Pressure : | 1015 hPa | Test Voltage : | DC 3.7V |
| Test Mode : | TX n Mode(40M) /CH03, CH06, CH09 | | |

CH 03

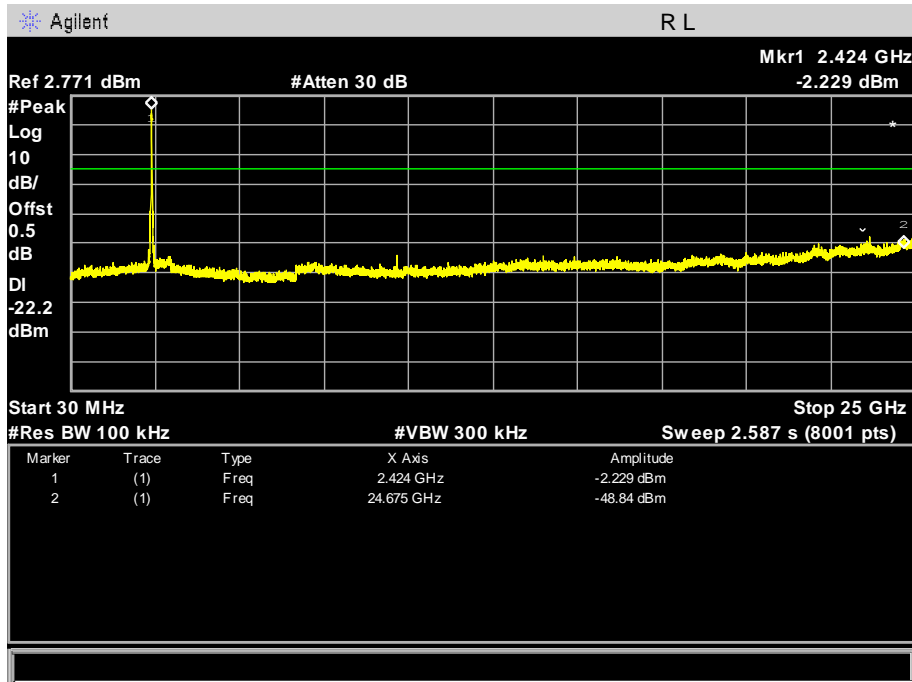



CH06

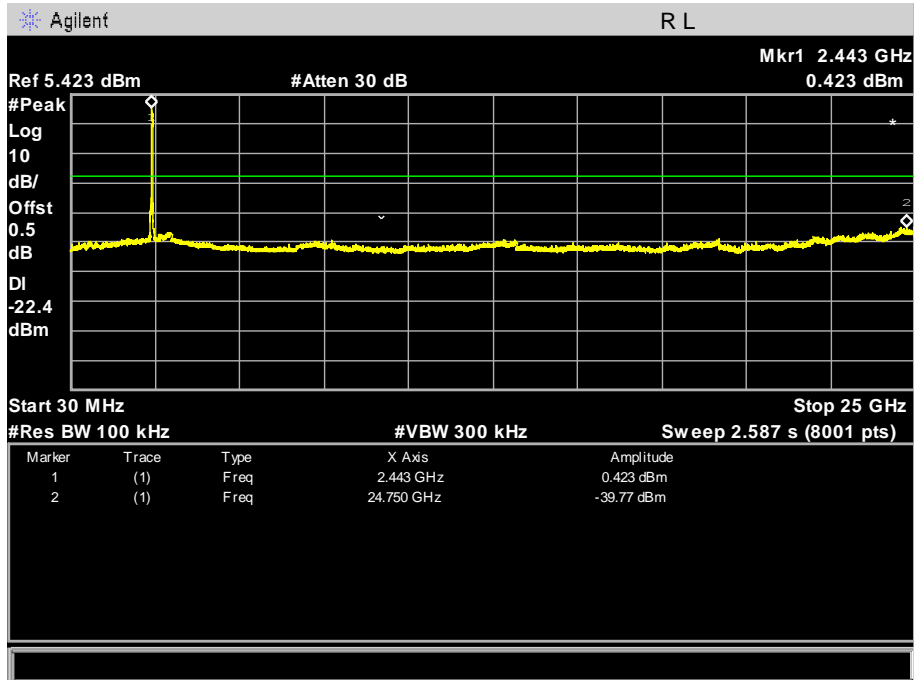

CH09

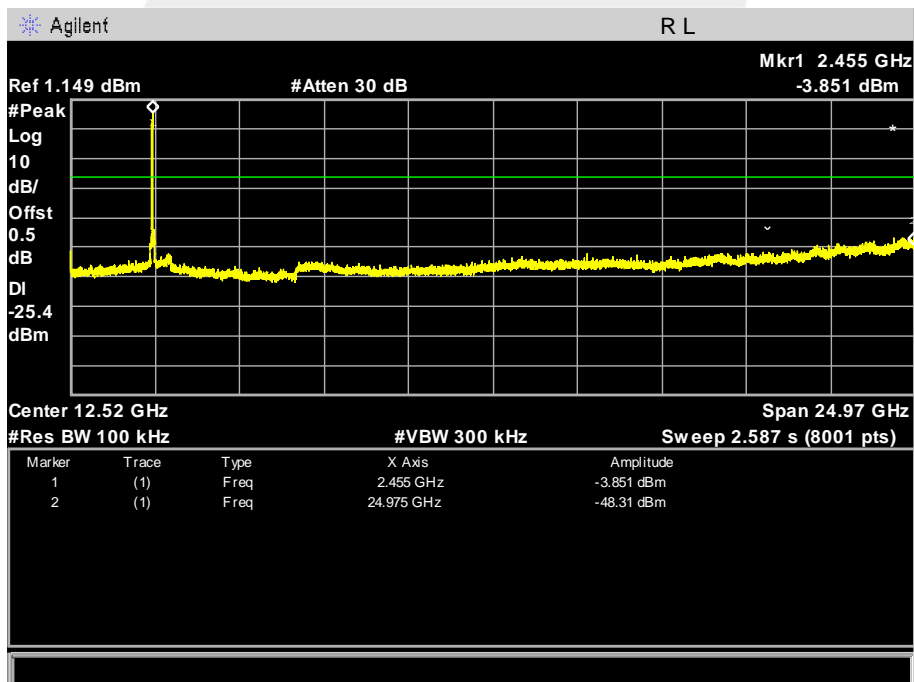



Band edge

CH03

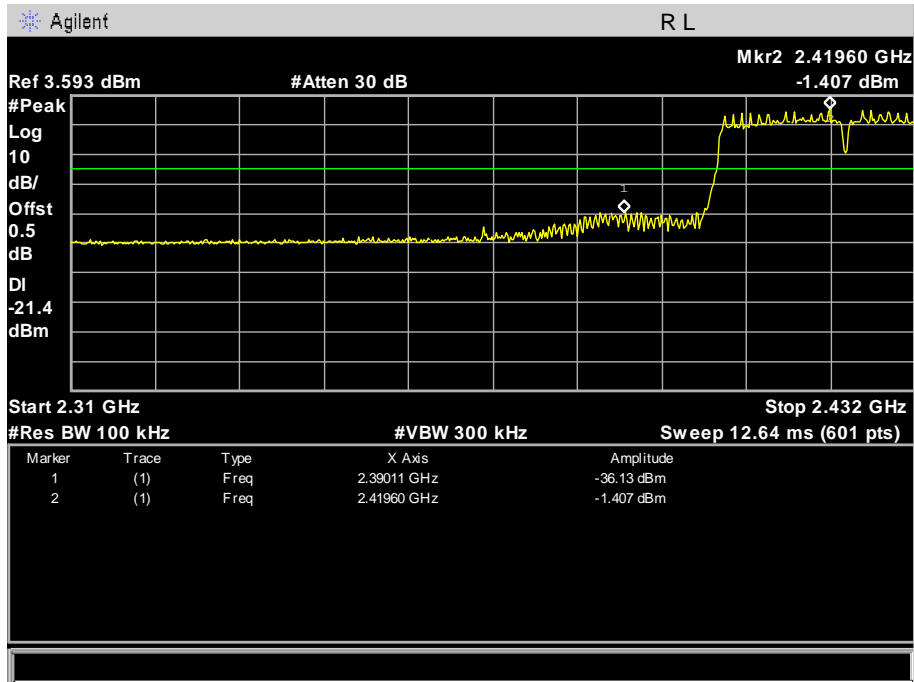

CH 09

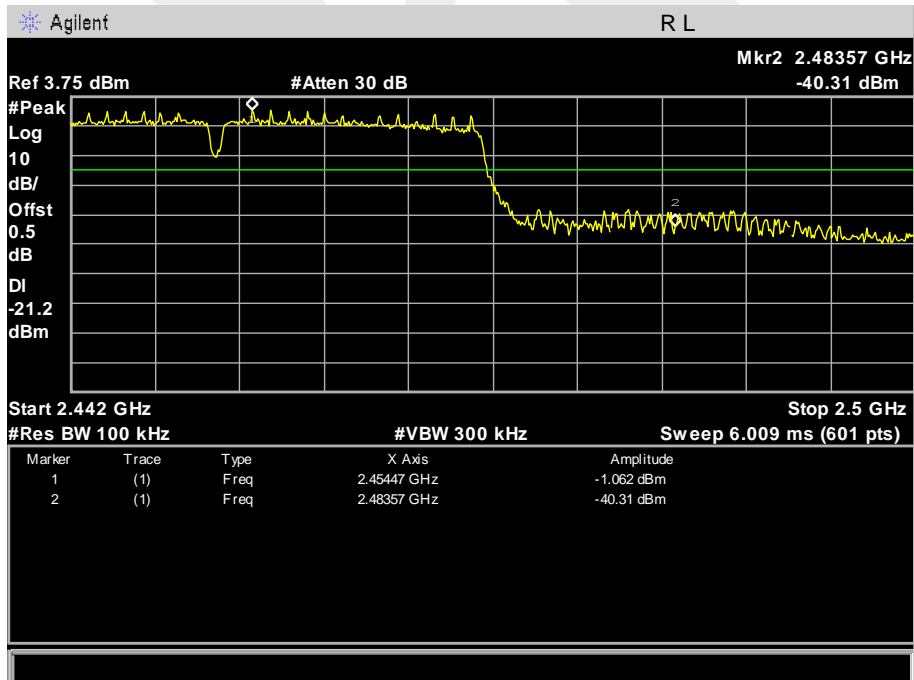



5. POWER SPECTRAL DENSITY TEST

5.1 APPLIED PROCEDURES / LIMIT

| FCC Part15 (15.247) , Subpart C | | | | |
|---------------------------------|------------------------|------------------------|-----------------------|--------|
| Section | Test Item | Limit | Frequency Range (MHz) | Result |
| 15.247 | Power Spectral Density | 8 dBm (in any 3KHz) | 2400-2483.5 | PASS |

5.2 TEST PROCEDURE

1. Set analyzer center frequency to DTS channel center frequency.
2. Set the span to 1.5 times the DTS channel bandwidth.
3. Set the RBW \geq 3 kHz.
4. Set the VBW \geq 3 x RBW.
5. Detector = peak.
6. Sweep time = auto couple.
7. Trace mode = max hold.
8. Allow trace to fully stabilize.
9. Use the peak marker function to determine the maximum amplitude level.
10. If measured value exceeds limit, reduce RBW (no less than 3 kHz) and repeat.

5.3 DEVIATION FROM STANDARD

No deviation.

5.4 TEST SETUP

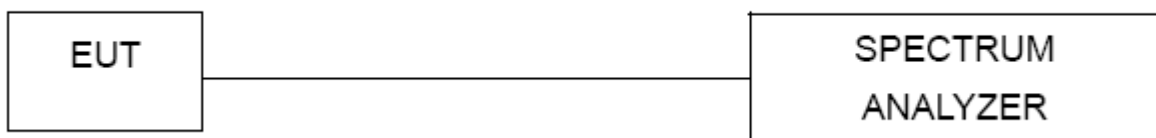

5.5 EUT OPERATION CONDITIONS

The EUT tested system was configured as the statements of 2.3 Unless otherwise a special operating condition is specified in the follows during the testing.

5.6 TEST RESULTS

| | | | |
|---------------|-----------------------------|---------------------|---------|
| Temperature : | 25 °C | Relative Humidity : | 60% |
| Pressure : | 1015 hPa | Test Voltage : | DC 3.7V |
| Test Mode : | TX b Mode /CH01, CH06, CH11 | | |



| Frequency | Power Density (dBm) | Limit (dBm) | Result |
|-----------|---------------------|-------------|--------|
| 2412 MHz | -4.992 | 8 | PASS |
| 2437 MHz | -4.761 | 8 | PASS |
| 2462 MHz | -3.789 | 8 | PASS |

TX CH01

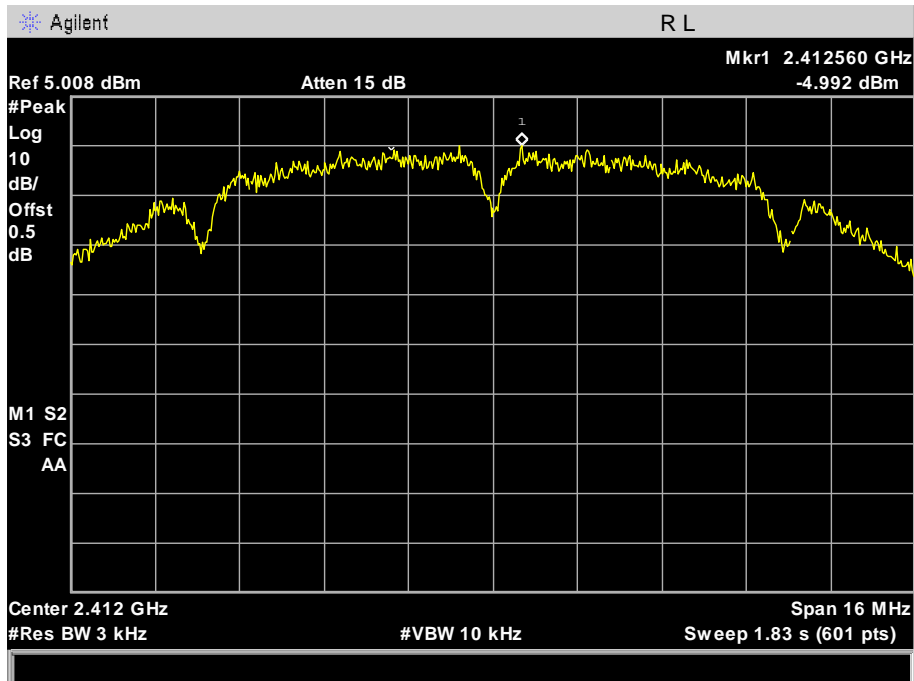



TX CH06

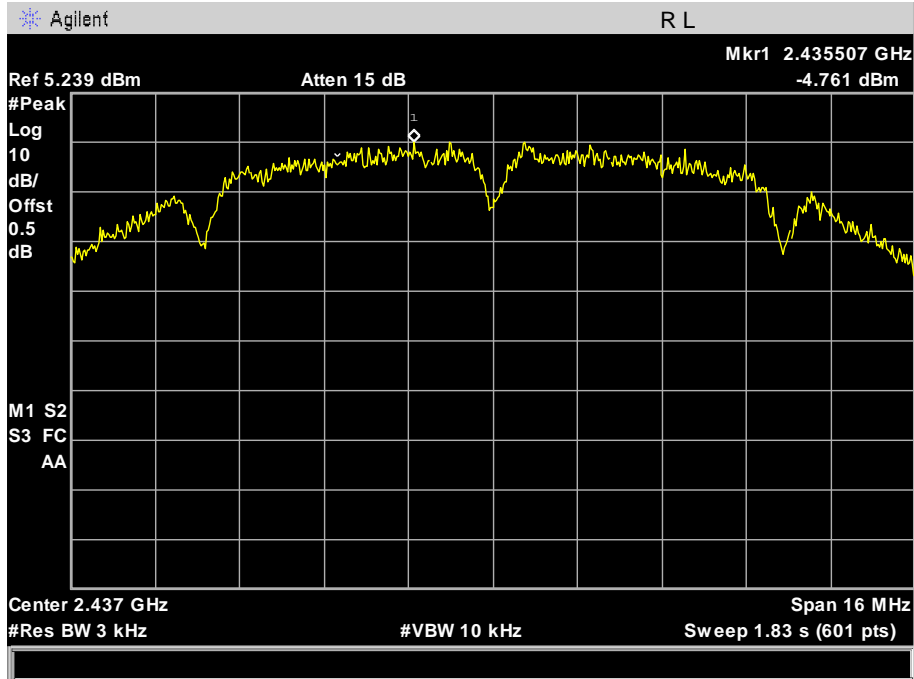

TX CH11

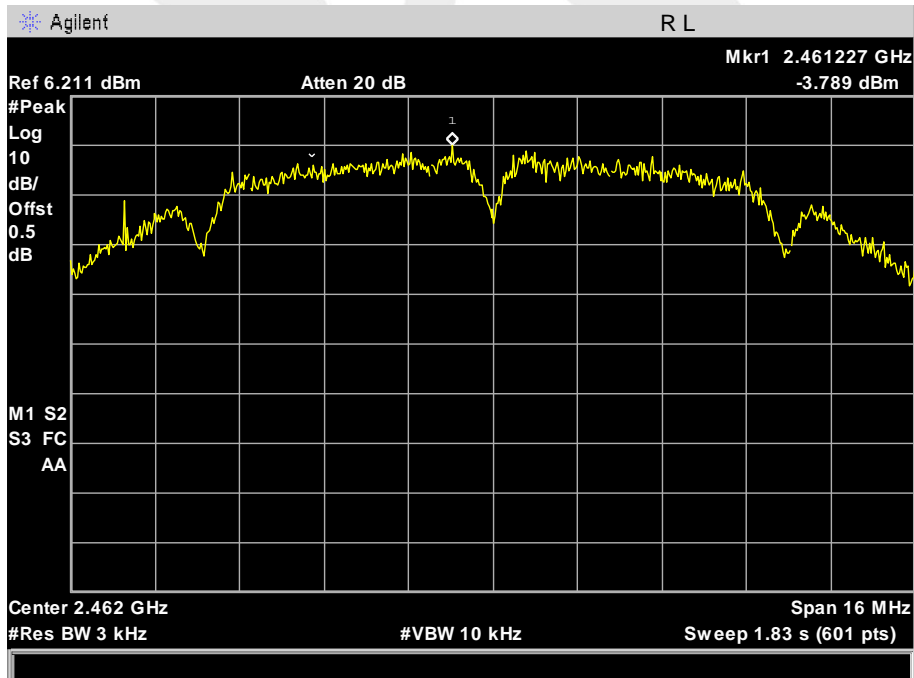



| | | | |
|---------------|-----------------------------|---------------------|---------|
| Temperature : | 25 °C | Relative Humidity : | 60% |
| Pressure : | 1015 hPa | Test Voltage : | DC 3.7V |
| Test Mode : | TX g Mode /CH01, CH06, CH11 | | |

| Frequency | Power Density (dBm) | Limit (dBm) | Result |
|-----------|---------------------|-------------|--------|
| 2412 MHz | -10.160 | 8 | PASS |
| 2437 MHz | -9.193 | 8 | PASS |
| 2462 MHz | -9.242 | 8 | PASS |

TX CH01

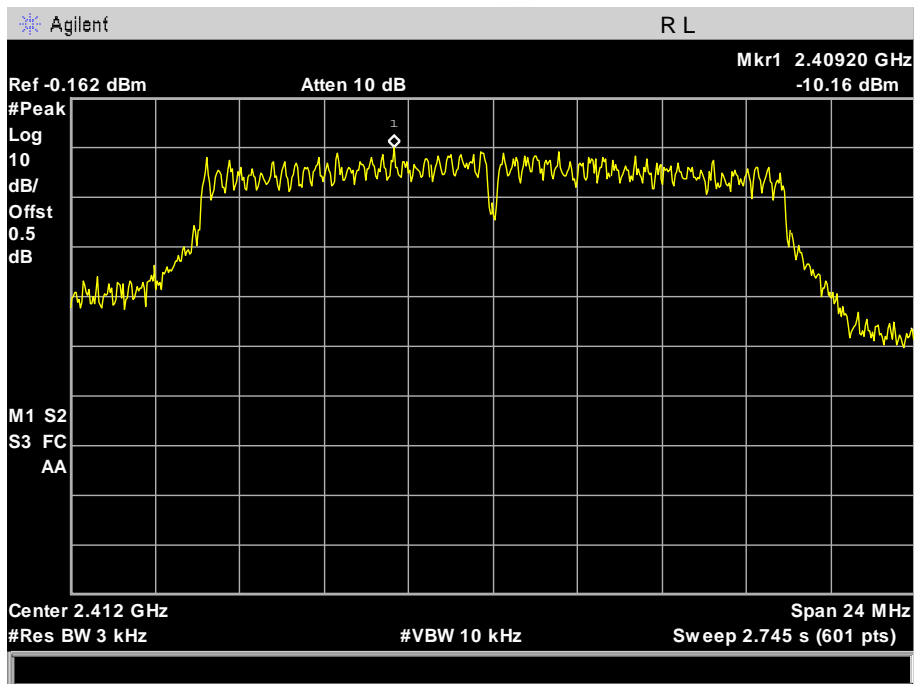



TX CH06

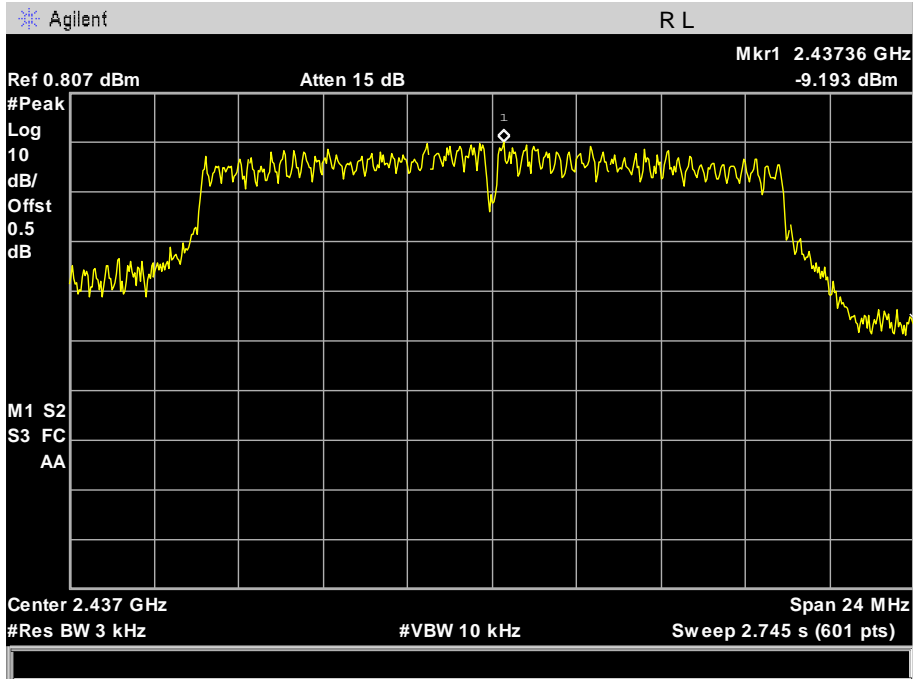

TX CH11

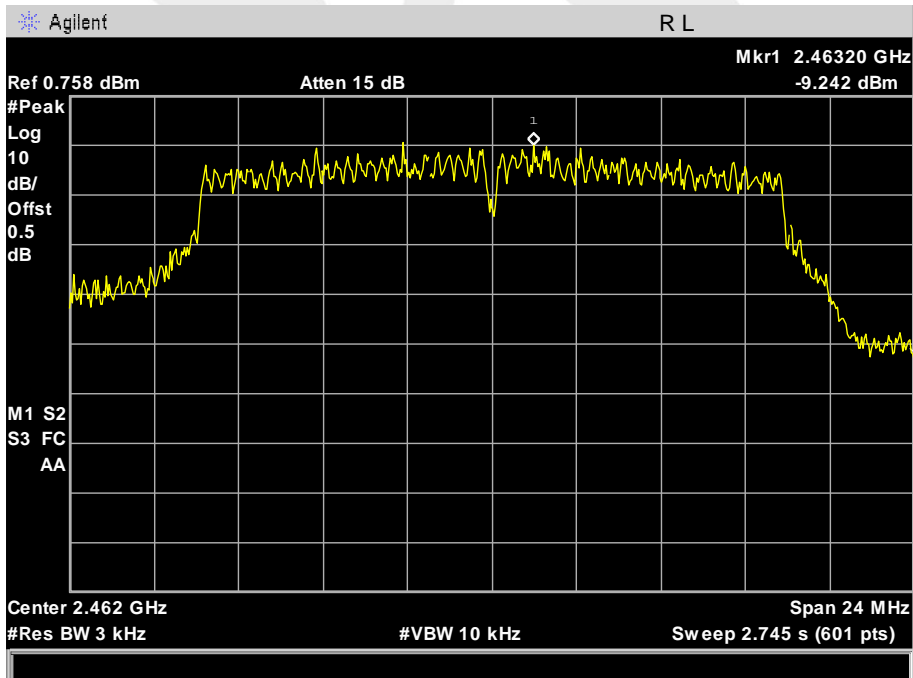



| | | | |
|---------------|----------------------------------|---------------------|---------|
| Temperature : | 25 °C | Relative Humidity : | 60% |
| Pressure : | 1015 hPa | Test Voltage : | DC 3.7V |
| Test Mode : | TX n Mode(20M) /CH01, CH06, CH11 | | |

| Frequency | Power Density (dBm) | Limit (dBm) | Result |
|-----------|---------------------|-------------|--------|
| 2412 MHz | -10.960 | 8 | PASS |
| 2437 MHz | -8.488 | 8 | PASS |
| 2462 MHz | -10.520 | 8 | PASS |

TX CH01

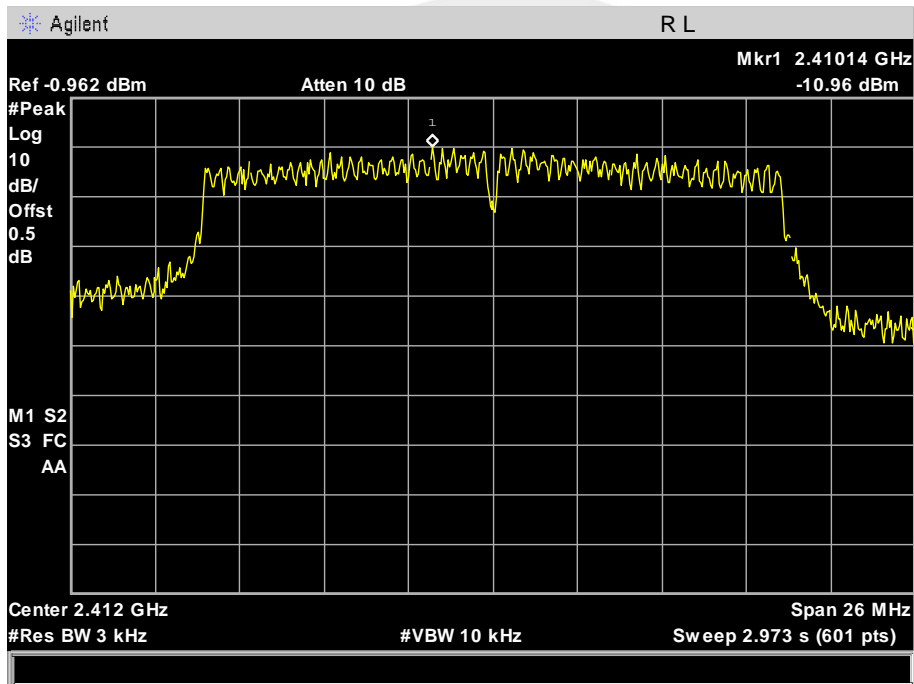



TX CH06

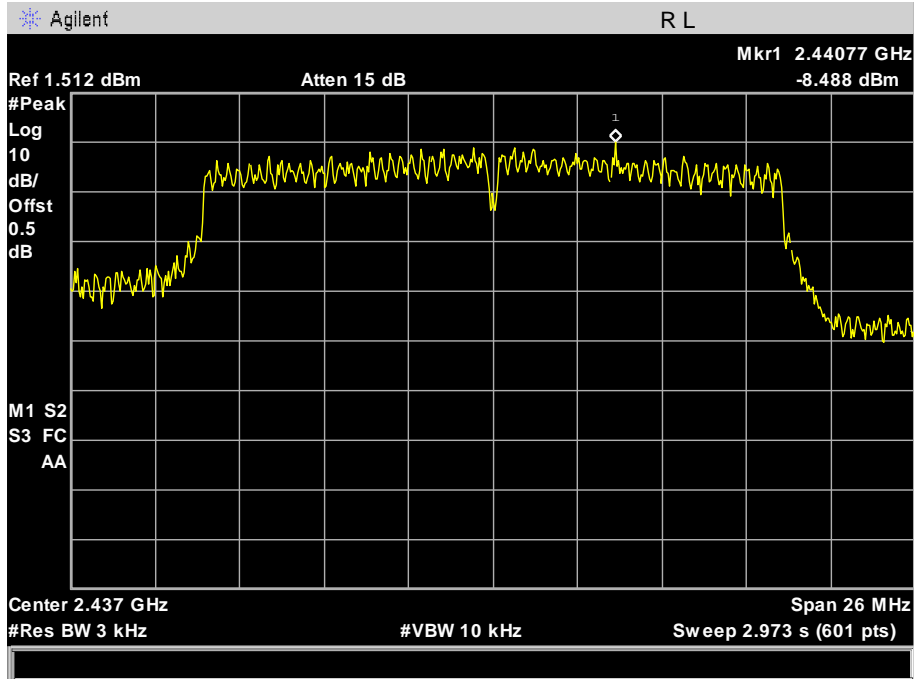

TX CH11

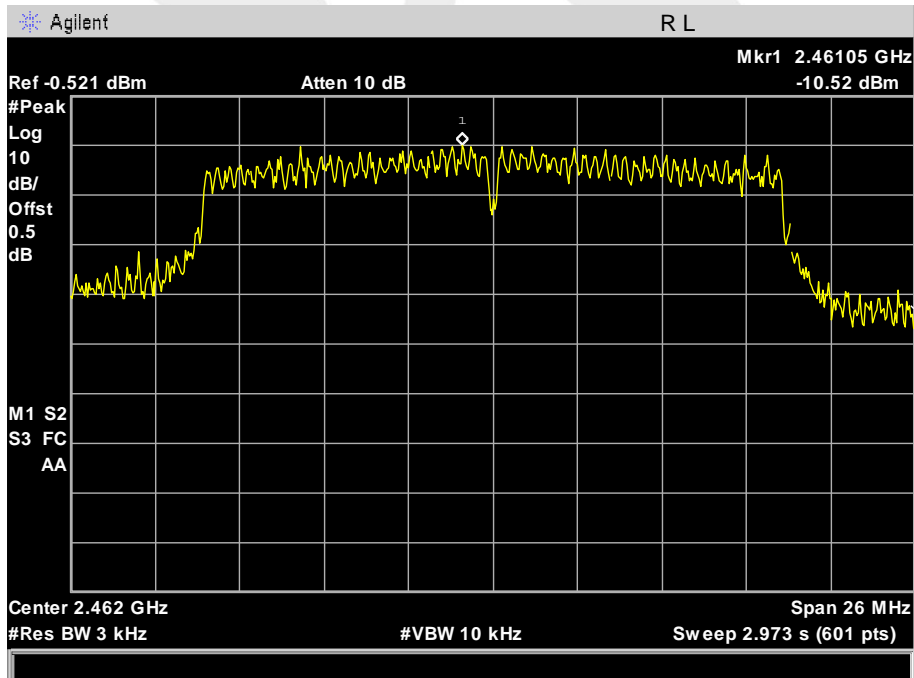



| | | | |
|---------------|----------------------------------|---------------------|---------|
| Temperature : | 25 °C | Relative Humidity : | 60% |
| Pressure : | 1015 hPa | Test Voltage : | DC 3.7V |
| Test Mode : | TX n Mode(40M) /CH03, CH06, CH09 | | |

| Frequency | Power Density (dBm) | Limit (dBm) | Result |
|-----------|---------------------|-------------|--------|
| 2422 MHz | -15.610 | 8 | PASS |
| 2437 MHz | -14.700 | 8 | PASS |
| 2452 MHz | -16.220 | 8 | PASS |

TX CH03

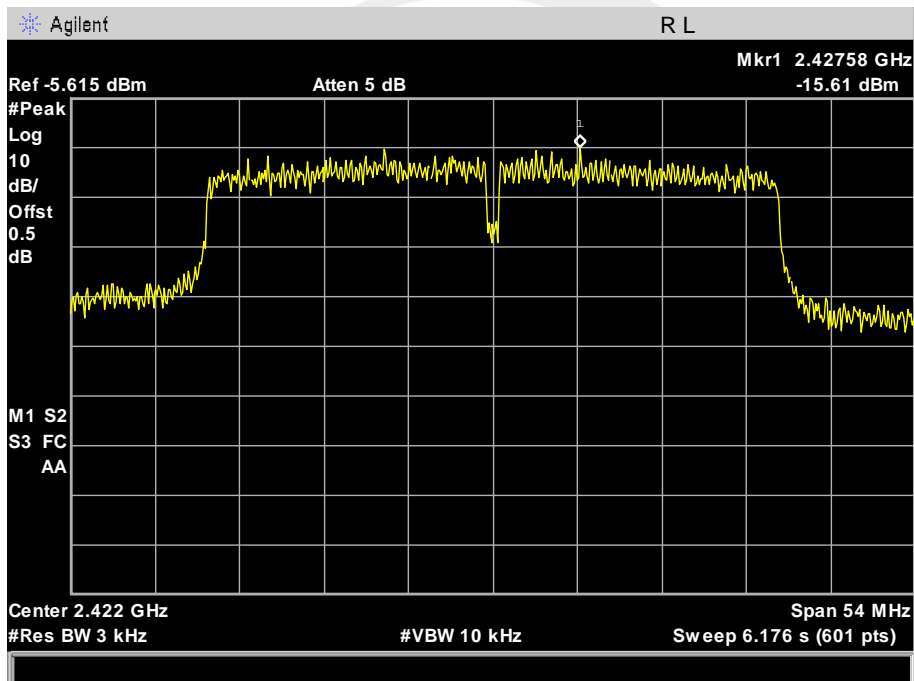



TX CH06

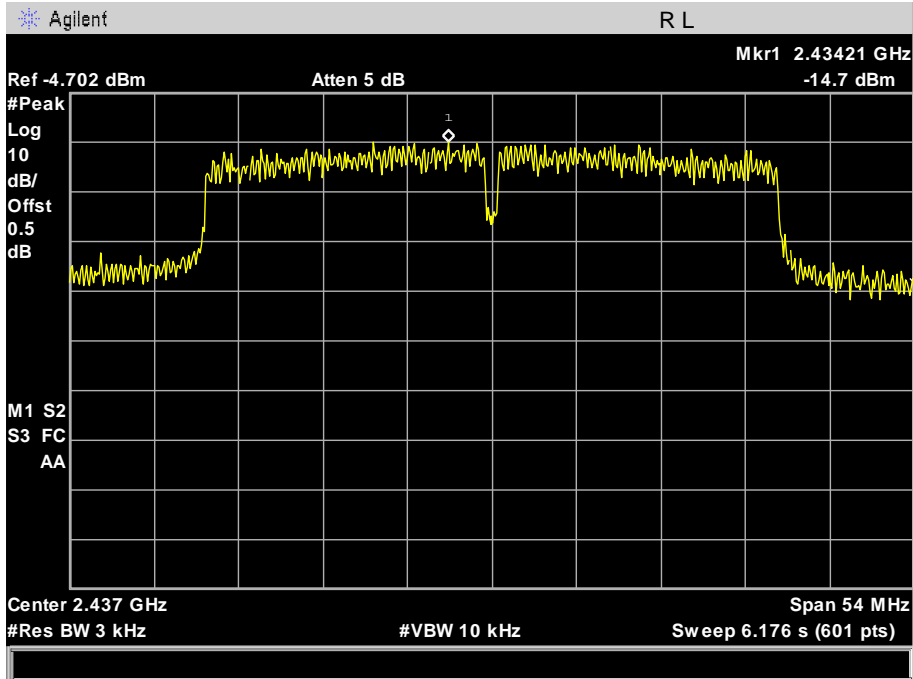

TX CH09

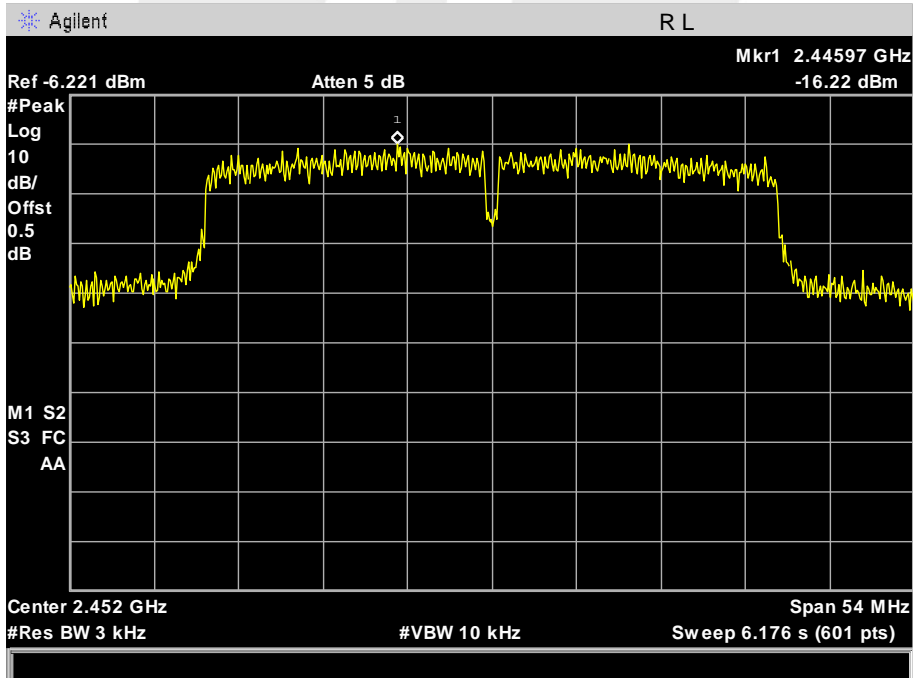



6. BANDWIDTH TEST

6.1 APPLIED PROCEDURES / LIMIT

| FCC Part15 (15.247) , Subpart C | | | | |
|---------------------------------|-----------|---|-----------------------|--------|
| Section | Test Item | Limit | Frequency Range (MHz) | Result |
| 15.247(a)(2) | Bandwidth | $\geq 500\text{KHz}$ (6dB bandwidth) | 2400-2483.5 | PASS |

6.2 TEST PROCEDURE

1. Set RBW = 100 kHz.
2. Set the video bandwidth (VBW) ≥ 3 RBW.
3. Detector = Peak.
4. Trace mode = max hold.
5. Sweep = auto couple.
6. Allow the trace to stabilize.
7. Measure the maximum width of the emission that is constrained by the frequencies associated with the two outermost amplitude points (upper and lower frequencies) that are attenuated by 6 dB relative to the maximum level measured in the fundamental emission.

6.3 DEVIATION FROM STANDARD

No deviation.

6.4 TEST SETUP



6.5 EUT OPERATION CONDITIONS

The EUT tested system was configured as the statements of 2.3 Unless otherwise a special operating condition is specified in the follows during the testing.



6.6 TEST RESULTS

| | | | |
|---------------|-----------------------------|---------------------|---------|
| Temperature : | 25 °C | Relative Humidity : | 60% |
| Pressure : | 1012 hPa | Test Voltage : | DC 3.7V |
| Test Mode : | TX b Mode /CH01, CH06, CH11 | | |

| Frequency | 6dB Bandwidth (MHz) | Channel Separation (KHz) | Result |
|-----------|---------------------|--------------------------|--------|
| 2412 MHz | 10.012 | >=500KHz | PASS |
| 2437 MHz | 9.090 | >=500KHz | PASS |
| 2462 MHz | 9.576 | >=500KHz | PASS |

TX CH 01

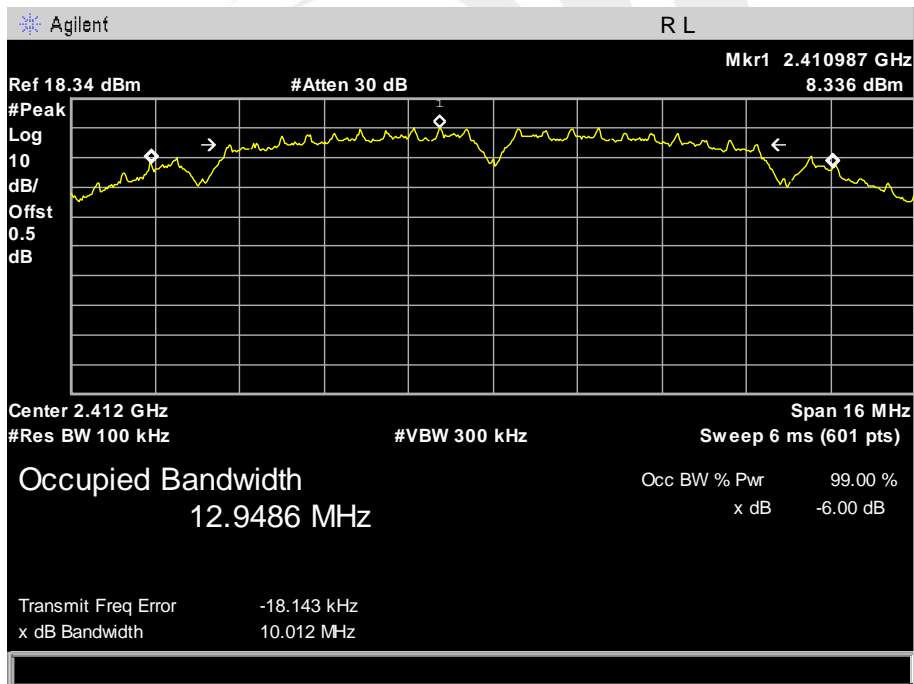



TX CH 06

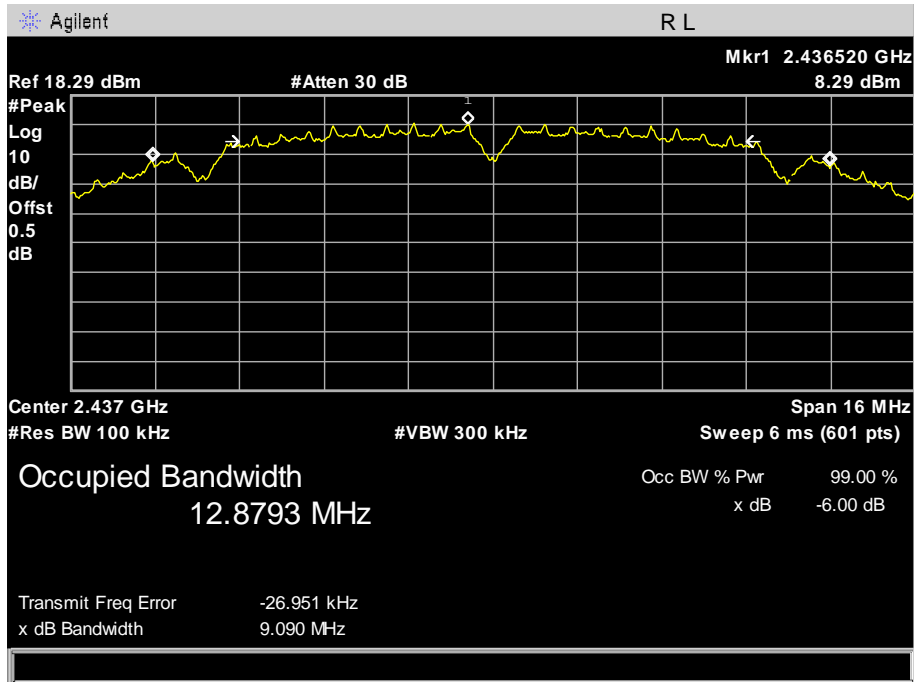

TX CH 11

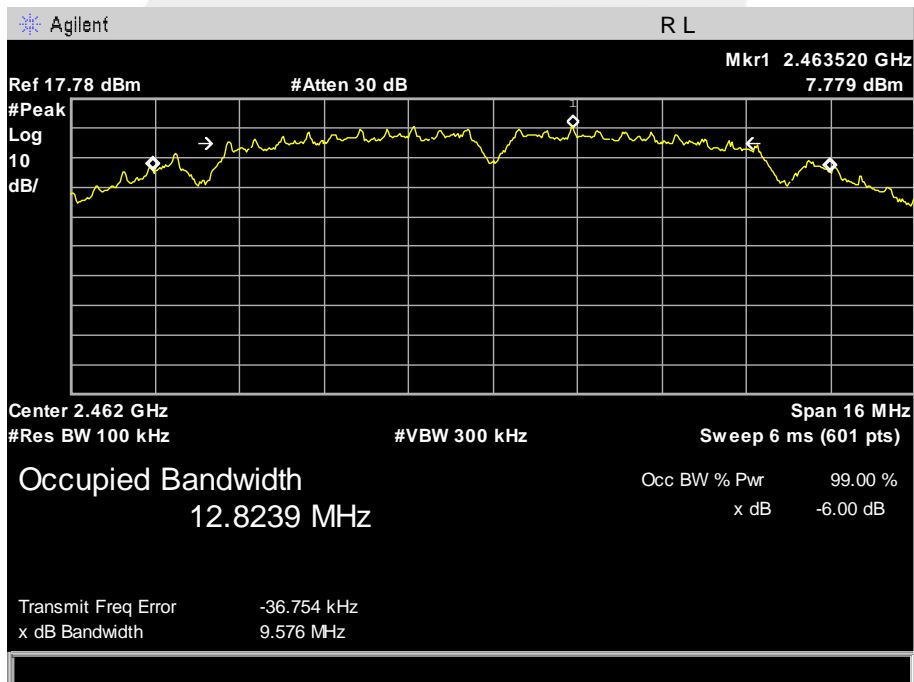



| | | | |
|---------------|-----------------------------|---------------------|---------|
| Temperature : | 25 °C | Relative Humidity : | 60% |
| Pressure : | 1012 hPa | Test Voltage : | DC 3.7V |
| Test Mode : | TX g Mode /CH01, CH06, CH11 | | |

| Frequency | 6dB Bandwidth (MHz) | Channel Separation (KHz) | Result |
|-----------|---------------------|--------------------------|--------|
| 2412 MHz | 15.873 | >=500KHz | PASS |
| 2437 MHz | 15.381 | >=500KHz | PASS |
| 2462 MHz | 15.251 | >=500KHz | PASS |

TX CH 01

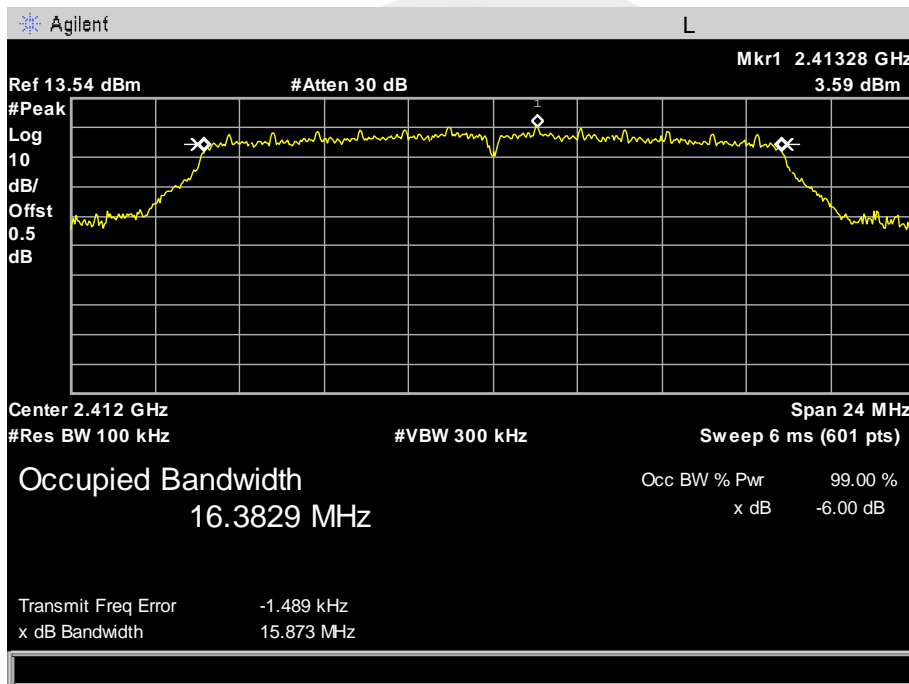



TX CH 06

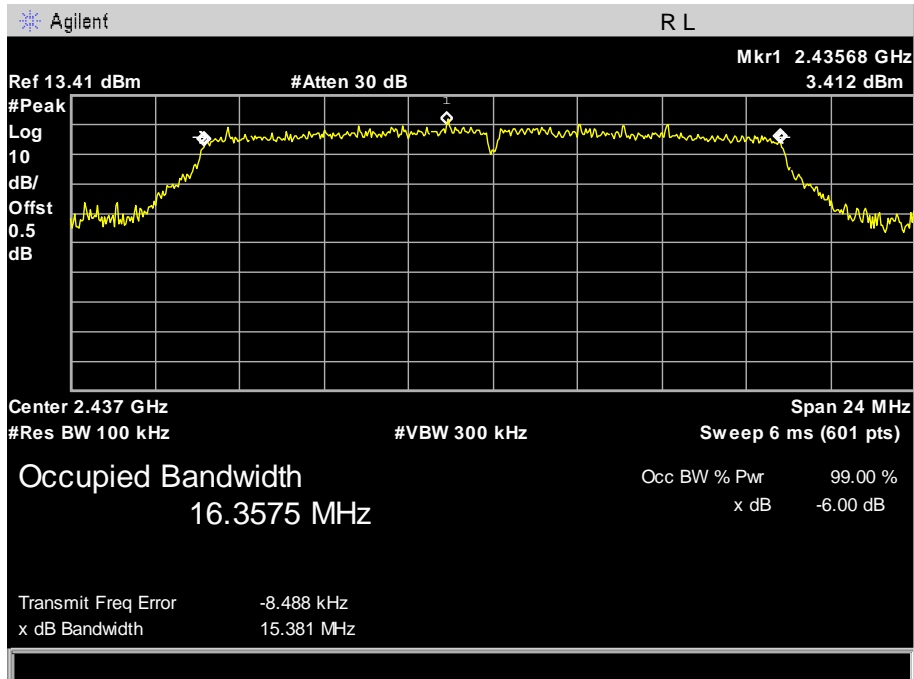

TX CH 11

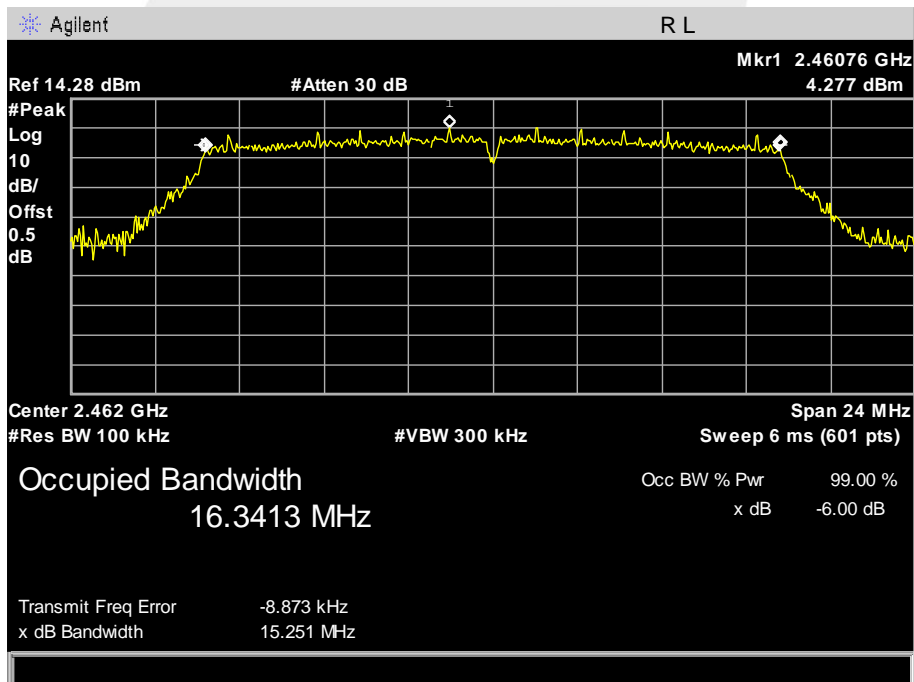



| | | | |
|---------------|----------------------------------|---------------------|---------|
| Temperature : | 25 °C | Relative Humidity : | 60% |
| Pressure : | 1012 hPa | Test Voltage : | DC 3.7V |
| Test Mode : | TX n Mode(20M) /CH01, CH06, CH11 | | |

| Frequency | 6dB Bandwidth (MHz) | Channel Separation (KHz) | Result |
|-----------|---------------------|--------------------------|--------|
| 2412 MHz | 16.775 | >=500KHz | PASS |
| 2437 MHz | 17.510 | >=500KHz | PASS |
| 2462 MHz | 16.730 | >=500KHz | PASS |

TX CH 01

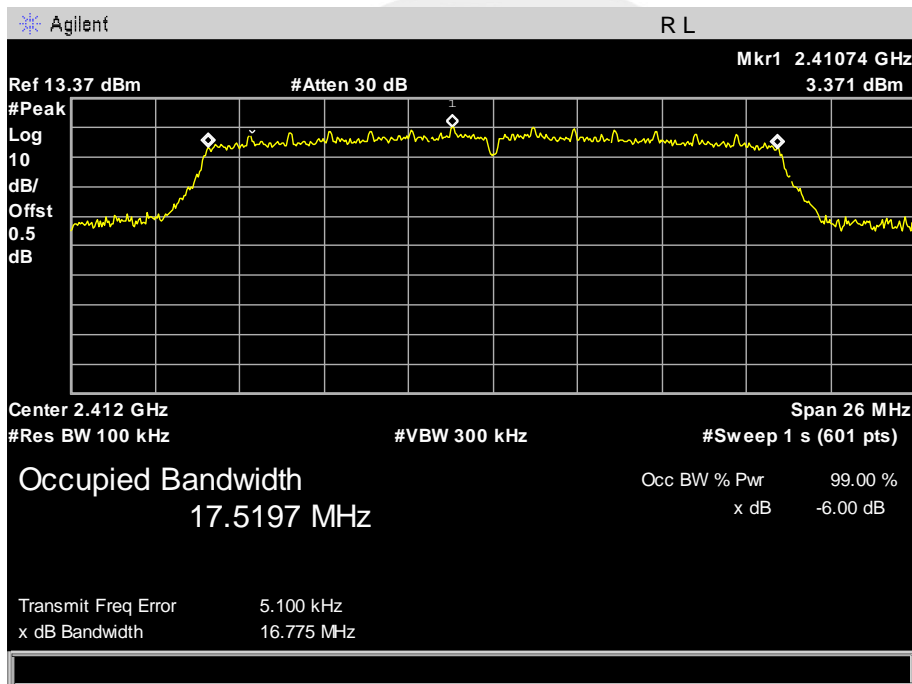



TX CH 06

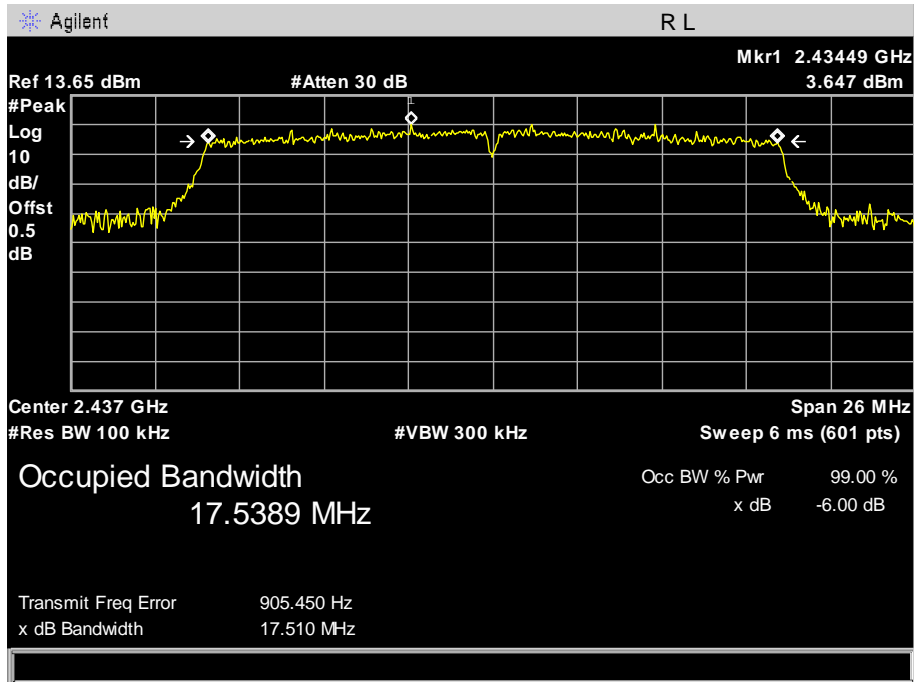

TX CH 11

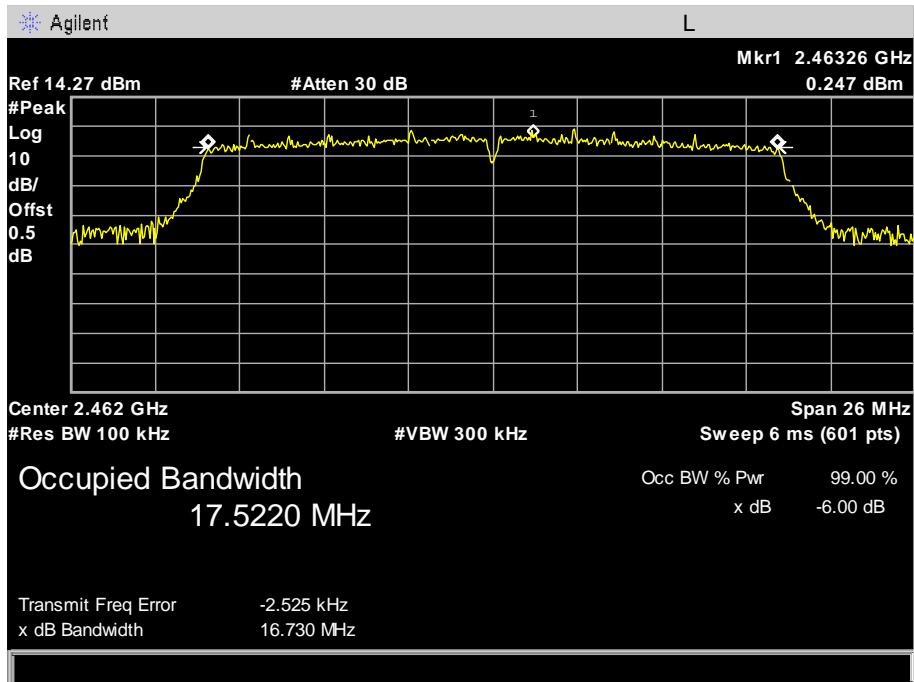



| | | | |
|---------------|----------------------------------|---------------------|---------|
| Temperature : | 25 °C | Relative Humidity : | 60% |
| Pressure : | 1012 hPa | Test Voltage : | DC 3.7V |
| Test Mode : | TX n Mode(40M) /CH03, CH06, CH09 | | |

| Frequency | 6dB Bandwidth (MHz) | Channel Separation (KHz) | Result |
|-----------|---------------------|--------------------------|--------|
| 2422 MHz | 35.255 | >=500KHz | PASS |
| 2437 MHz | 35.342 | >=500KHz | PASS |
| 2452 MHz | 35.385 | >=500KHz | PASS |

TX CH 03

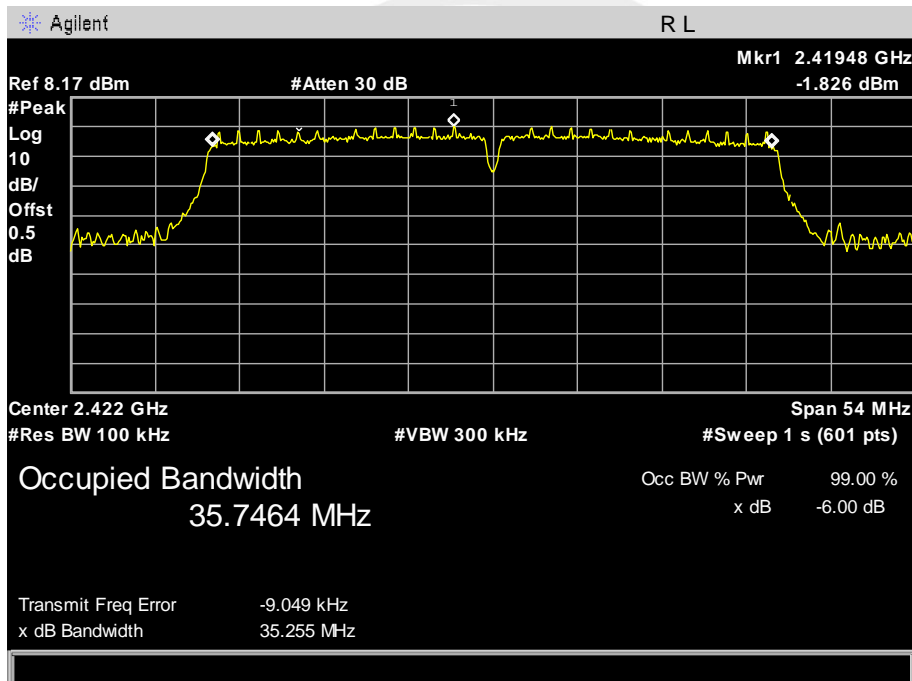



TX CH 06

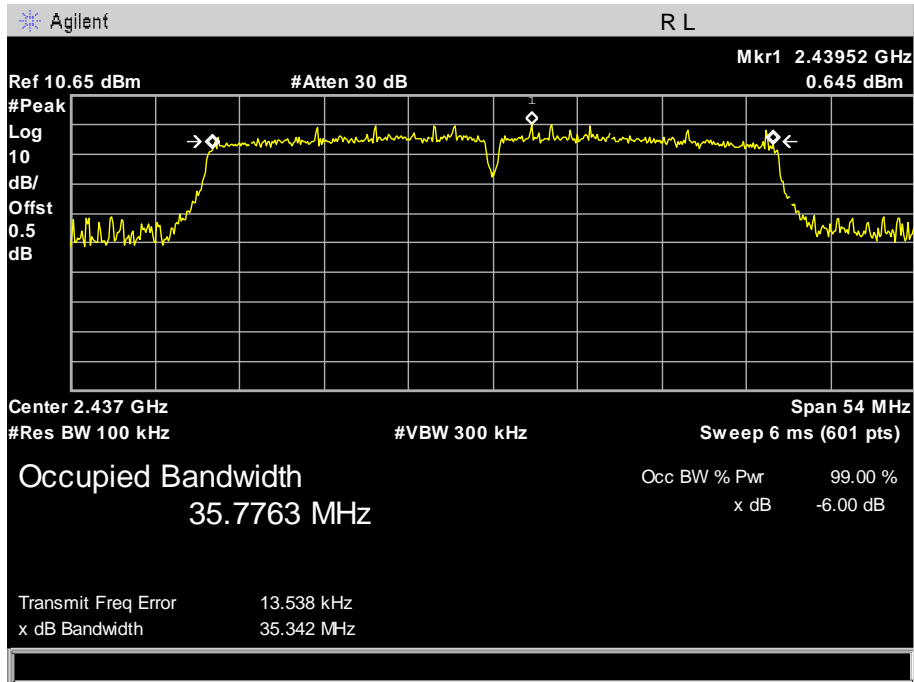

TX CH 09

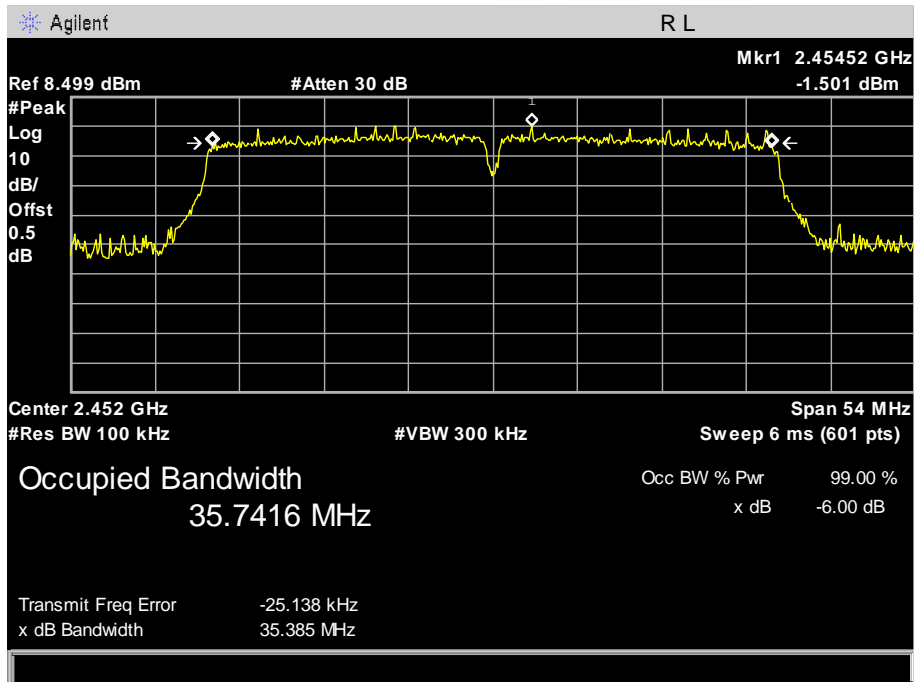



7. PEAK OUTPUT POWER TEST

7.1 APPLIED PROCEDURES / LIMIT

| FCC Part15 (15.247) , Subpart C | | | | |
|---------------------------------|-------------------|-----------------|-----------------------|--------|
| Section | Test Item | Limit | Frequency Range (MHz) | Result |
| 15.247(b)(3) | Peak Output Power | 1 watt or 30dBm | 2400-2483.5 | PASS |

7.2 TEST PROCEDURE

- a. The EUT was directly connected to the Power Sensor&Power meter

7.3 DEVIATION FROM STANDARD

No deviation.

7.4 TEST SETUP



7.5 EUT OPERATION CONDITIONS

The EUT tested system was configured as the statements of 2.3 Unless otherwise a special operating condition is specified in the follows during the testing.



7.6 TEST RESULTS

| | | | |
|---------------|--|---------------------|---------|
| Temperature : | 25 °C | Relative Humidity : | 60% |
| Pressure : | 1012 hPa | Test Voltage : | DC 3.7V |
| Test Mode : | TX b/g/n(20M,40M) Mode /CH01, CH06, CH11 | | |

| TX 802.11b Mode | | | | |
|-----------------|-----------|------------------------|----------|-------|
| Test Channe | Frequency | Conducted Output Power | | LIMIT |
| | (MHz) | Peak(dBm) | AVG(dBm) | dBm |
| CH01 | 2412 | 18.6 | 16.2 | 30 |
| CH06 | 2437 | 18.4 | 16.6 | 30 |
| CH11 | 2462 | 18.6 | 16.4 | 30 |

| TX 802.11g Mode | | | | |
|-----------------|-----------|------------------------|----------|-------|
| Test Channe | Frequency | Conducted Output Power | | LIMIT |
| | (MHz) | Peak(dBm) | AVG(dBm) | dBm |
| CH01 | 2412 | 15.3 | 13.1 | 30 |
| CH06 | 2437 | 16.3 | 13.3 | 30 |
| CH11 | 2462 | 15.5 | 13.5 | 30 |

| TX 802.11n20 Mode | | | | |
|-------------------|-----------|------------------------|----------|-------|
| Test Channe | Frequency | Conducted Output Power | | LIMIT |
| | (MHz) | Peak(dBm) | AVG(dBm) | dBm |
| CH01 | 2412 | 15.1 | 14.2 | 30 |
| CH06 | 2437 | 16.3 | 14.6 | 30 |
| CH11 | 2462 | 15.6 | 14.3 | 30 |

| TX 802.11n40 Mode | | | | |
|-------------------|-----------|------------------------|----------|-------|
| Test Channe | Frequency | Conducted Output Power | | LIMIT |
| | (MHz) | Peak(dBm) | AVG(dBm) | dBm |
| CH03 | 2422 | 12.8 | 10.2 | 30 |
| CH06 | 2437 | 14.4 | 10.8 | 30 |
| CH09 | 2452 | 12.9 | 10.1 | 30 |



8. ANTENNA REQUIREMENT

8.1 STANDARD REQUIREMENT

15.203 requirement: For intentional device, according to 15.203: an intentional radiator shall be designed to ensure that no antenna other than that furnished by the responsible party shall be used with the device.

8.2 EUT ANTENNA

The EUT antenna is PIFA Antenna. It comply with the standard requirement.



APPENDIX - PHOTOS OF TEST SETUP

Radiated Measurement Photos

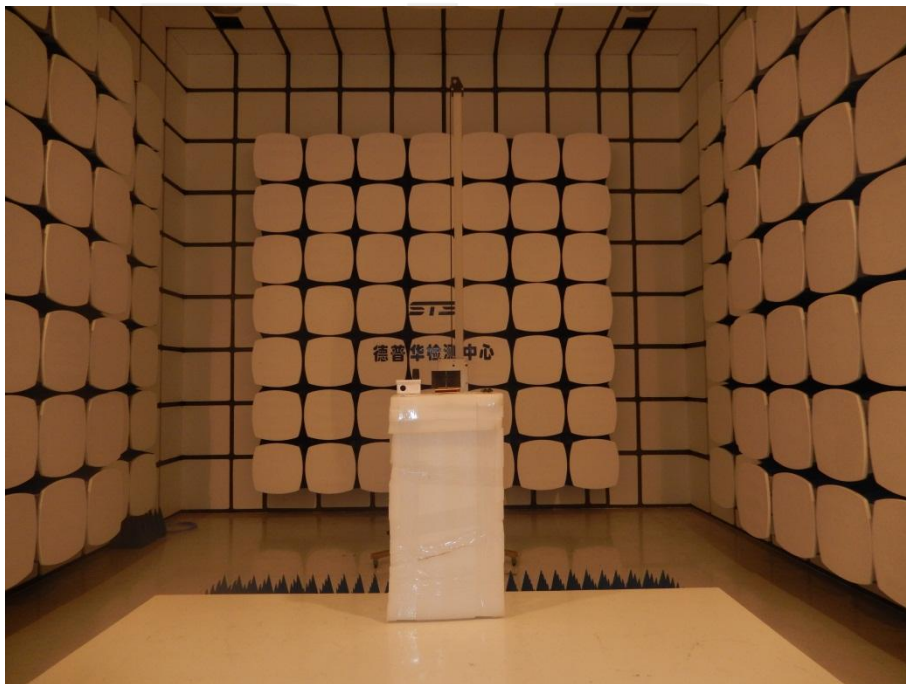
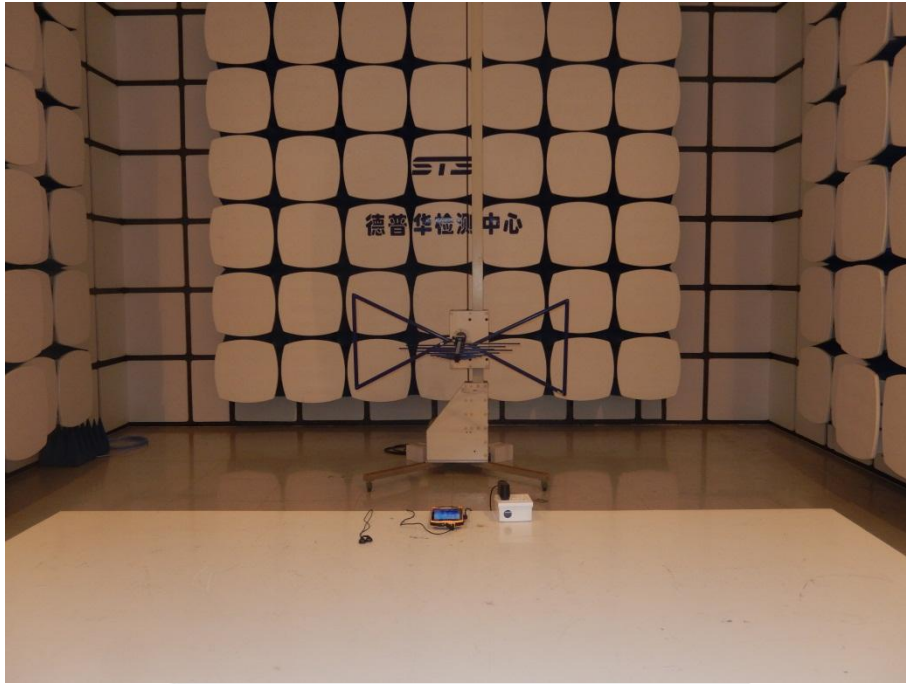

Conducted Measurement Photos



*****END OF THE REPORT*****