

FCC Radio Test Report

FCC ID: 2AJ9Z-X11

Original Grant

Report No. : TB-FCC156190
Applicant : EMATIC LIMITED
Equipment Under Test (EUT)
EUT Name : ROCK X11
Model No. : ROCK X11
Series No. : N/A
Brand Name : EXTREM
Receipt Date : 2017-06-23
Test Date : 2017-06-24 to 2017-07-09
Issue Date : 2017-07-10
Standards : FCC Part 2
FCC Part 22 Subpart H, FCC Part 24 Subpart E, 2016
ANSI/TIAC63.26: 2015

Conclusions : **PASS**

In the configuration tested, the EUT complied with the standards specified above,
The EUT technically complies with the FCC requirements

Test/Witness Engineer :

IWAN SU

Approved & Authorized :

Ray Lai



This report details the results of the testing carried out on one sample. The results contained in this test report do not relate to other samples of the same product. The manufacturer should ensure that all products in series production are in conformity with the product sample detailed in the report.

Contents

CONTENTS	2
1. GENERAL INFORMATION ABOUT EUT	4
1.1 Client Information.....	4
1.2 General Description of EUT (Equipment Under Test)	4
1.3 Block Diagram Showing the Configuration of System Tested.....	5
1.4 Description of Support Units	5
1.5 Description of Test Mode.....	5
1.6 Measurement Uncertainty	7
1.7 Test Facility.....	7
2. TEST SUMMARY	8
3. TEST EQUIPMENT	9
4. FREQUENCY STABILITY	10
4.1 Test Standard and Requirement	10
4.2 Test Setup.....	10
4.3 Test Procedure.....	11
4.4 EUT Operating Condition	11
5. CONDUCTED RF OUTPUT POWER	15
5.1 Test Standard and Limit.....	15
5.2 Test Setup.....	15
5.3 Test Procedure.....	15
5.4 EUT Operating Condition	15
5.5 EUT Operating Condition	15
6. PEAK-AVERAGE RATIO	20
6.1 Test Standard and Limit.....	20
6.2 Test Setup.....	20
6.3 Test Procedure.....	20
6.4 EUT Operating Condition	20
6.5 Test Data.....	21
7. RADIATED OUTPUT POWER	25
7.1 Test Standard and Limit.....	25
7.2 Test Setup.....	25
7.3 Test Procedure.....	26
7.4 EUT Operating Condition	26
7.5 Test Data.....	27
8. OCCUPIED BANDWIDTH	30
8.1 Test Standard and Limit.....	30
8.2 Test Setup.....	30

8.3 Test Procedure.....	30
8.4 EUT Operating Condition	31
8.5 Test Data.....	31
9. CONDUCTED OUT OF BAND EMISSIONS.....	58
9.1 Test Standard and Limit.....	58
9.2 Test Setup.....	58
9.3 Test Procedure.....	58
9.4 EUT Operating Condition	58
9.5 Test Data.....	59
Please refer following plots:.....	59
10. BAND EDGE TEST	83
10.1 Test Standard and Limit	83
10.2 Test Setup.....	83
10.3 Test Procedure.....	83
10.4 EUT Operating Condition	83
10.5 Test Data.....	84
11. RADIATED OUT BAND OF EMISSIONS.....	96
11.1 Test Standard and Limit	96
11.2 Test Setup.....	96
11.3 Test Procedure.....	96
11.4 EUT Operating Condition	97
11.5 Test Data.....	97

1. General Information about EUT

1.1 Client Information

Applicant : EMATIC LIMITED
Address : Unit 17, 9/F Tower A, New Mandarin Plaza NO, 14 Science Museum Rd, TST, Hong Kong, China
Manufacturer : EMATIC LIMITED
Address : Unit 17, 9/F Tower A, New Mandarin Plaza NO, 14 Science Museum Rd, TST, Hong Kong, China

1.2 General Description of EUT (Equipment Under Test)

EUT Name	:	ROCK X11
Models No.	:	ROCK X11
Model Difference	:	N/A
Product Description	:	Frequency Bands: GSM850; PCS1900; UMTS FDD Band II; UMTS FDD Band V
		GSM 850 Power : Cond:32.95 dBm ERP:31.99 dBm
		PCS 1900 Power : Cond:29.59 dBm EIRP:29.21 dBm
		UMTS Band II Power: Cond:22.87 dBm EIRP:21.95 dBm
		UMTS Band V Power: Cond:22.43 dBm ERP:21.94 dBm
		Antenna Gain: GSM 850: 0.57 dBi PCS 1900: 0.57 dBi WCDMA Band V: 0.75 dBi WCDMA Band II: 0.75 dBi
	Modulation Type: GSM/GPRS:GMSK EDGE: 8PSK UMTS:QPSK	
FCC Operating Frequency	:	GSM 850: 824.20MHz-848.80MHz PCS1900: 1850.20MHz-1909.80MHz UMTS Band II: 1852.40MHz-1907.60MHz UMTS Band V:826.40MHz-846.60MHz
Emission Designator	:	GSM 850: 248KGXW, PCS 1900: 247KGXW GPRS 850: 247KG7W, GPRS 1900: 252KG7W EGPRS 850: 244KG7W, EGPRS 1900: 256KG7W UMTS Band V: 4M25F9W, UMTS Band II: 4M22F9W
Power Supply	:	DC power supplied by AC/DC Adapter. DC Voltage supplied from Li-ion battery.

Power Rating	:	AC/DC Adapter(A138A-120150U-US2): Input: AC 100~240V 50/60Hz, 0.5A. Output: 5V/2.5A&9V/2A&12V/1.5A. DC 3.8V from 10000mA Li-ion battery.
Connecting I/O Port(S)	:	Please refer to the User's Manual

Note:

- (1) For a more detailed features description, please refer to the manufacturer's specifications or the User's Manual.
- (2) This test report only product for PCE-PCS Licensed Transmitter Held to ear..

1.3 Block Diagram Showing the Configuration of System Tested

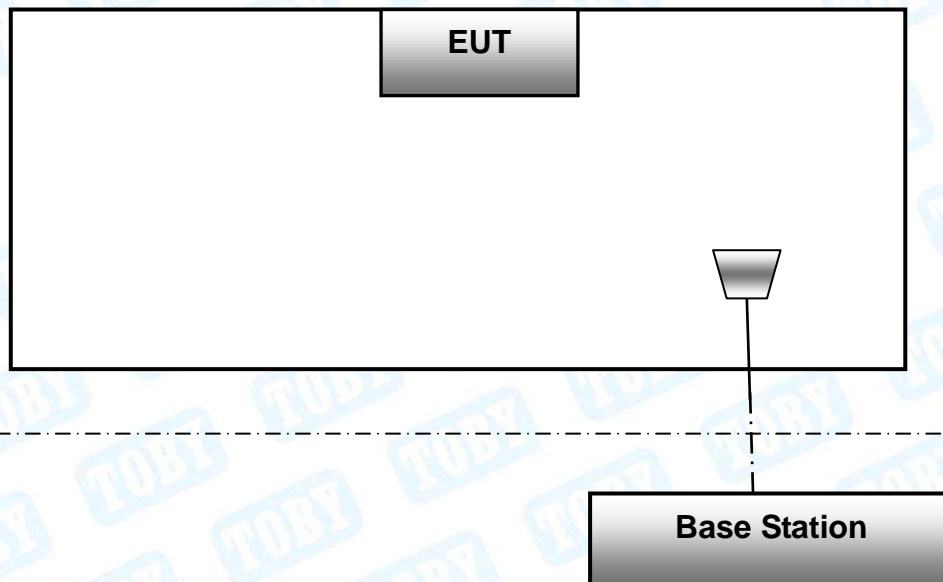

The above block diagram of setup is the normal mode. And more detail please refer to the test setup of each test item of bellow.

1.4 Description of Support Units

The EUT has been tested as an independent unit.

1.5 Description of Test Mode

To investigate the maximum EMI emission characteristics generates from EUT, the test system was pre-scanning tested base on the consideration of following EUT operation mode or test configuration mode which possible have effect on EMI emission level. Each of these EUT operation mode(s) or test configuration mode(s) mentioned follow was evaluated respectively.

During all testing, EUT is link mode with base station at maximum power level. The spurious emission measurements were carried out in semi-anechoic chamber with 3-meter test range. Frequency range investigated for radiated emission as below:

1. 9kHz~10GHz for GSM850 and UMTS Band V.
2. 9kHz~20GHz for PCS1900 and UMTS Band II.

Test Channel		
Mode	Channel	Frequency(MHz)
GSM 850	128	824.20
	190	836.60
	251	848.80
PCS 1900	512	1850.20
	661	1880.00
	810	1909.80
UMTS Band V	4132	826.40
	4183	836.60
	4233	846.60
UMTS Band II	9262	1852.40
	9400	1880.00
	9538	1907.60
Pre-scanning test Mode		Description
GSM 850		highest , middle, lowest channels
GPRS 850		highest , middle, lowest channels
GSM 1900		highest , middle, lowest channels
GPRS 1900		highest , middle, lowest channels
RMC UMTS Band V		highest , middle, lowest channels
HSDPA UMTS Band V		highest , middle, lowest channels
HSUPA UMTS Band V		highest , middle, lowest channels
RMC UMTS Band II		highest , middle, lowest channels
HSDPA UMTS Band II		highest , middle, lowest channels
HSUPA UMTS Band II		highest , middle, lowest channels
Final test Mode		Description
GSM 850		highest , middle, lowest channels
GSM 1900		highest , middle, lowest channels
RMC UMTS 850		highest , middle, lowest channels
RMC UMTS Band II		highest , middle, lowest channels

Note:

(1) The measurements are performed at the highest, middle, lowest available channels.

- (2) During the testing procedure, the EUT is in link mode with base station emulator at maximum power level in each test mode.
- (3) The EUT has GSM, GPRS, EDGE functions, and after pre-testing, GSM function is the worst case for all the emission tests.
- (4) The EUT has RMC, HSDPA, HSUPA functions in UMTS band II and UMTS band V, and after pre-testing, RMC mode is the worst case for all the emission tests.
- (5) The EUT is considered a portable unit; it was pre-tested on the positioned of each 3 axis, X-plane, Y-plane and Z-plane. The worst case was found positioned on Z-plane as the normal use. Therefore only the test data of this Z-plane was used for radiated emission measurement test.

1.6 Measurement Uncertainty

Test Item	Parameters	Expanded Uncertainty (U _{Lab})
Conducted Emission	Level Accuracy: 9kHz~150kHz 150kHz to 30MHz	±3.42 dB ±3.42 dB
Radiated Emission	Level Accuracy: 9kHz to 30 MHz	±4.60 dB
Radiated Emission	Level Accuracy: 30MHz to 1000 MHz	±4.40 dB
Radiated Emission	Level Accuracy: Above 1000MHz	±4.20 dB

1.7 Test Facility

The testing was performed by the Shenzhen Toby Technology Co., Ltd., in their facilities located at: 1A/F., Bldg.6, Yusheng Industrial Zone, The National Road No.107 Xixiang Section 467, Xixiang, Bao'an, Shenzhen, Guangdong, China.

At the time of testing, the following bodies accredited the Laboratory:

CNAS (L5813)

The Laboratory has been accredited by CNAS to ISO/IEC 17025: 2005 General Requirements for the Competence of Testing and Calibration Laboratories for the competence in the field of testing. And the Registration No.: CNAS L5813.

FCC List No.: (811562)

The Laboratory is listed in the United States of American Federal Communications Commission (FCC), and the registration number is 811562.

IC Registration No.: (11950A-1)

The Laboratory has been registered by Certification and Engineering Bureau of Industry Canada for radio equipment testing. The site registration: Site# 11950A-1.

2. Test Summary

Test Standards and Test Results			
Standard	Document Title		
FCC Part 2 (10-1-05 Edition)	Frequency Allocations and Radio Treaty Matters; General Rules and Regulations		
FCC Part 22 (10-1-05 Edition)	Public Mobile Services		
FCC Part 24 (10-1-05 Edition)	Personal Communications Services		
Standard Section	Test Item	Judgment	Remark
2.1046	Conducted RF Output Power	PASS	N/A
24.232(d)	Peak-Average Ratio	PASS	N/A
2.1049; 22.917; 24.238	99% & -26 dB Occupied Bandwidth	PASS	N/A
2.1055; 22.355; 24.235	Frequency Stability	PASS	N/A
2.1051; 2.1057; 22.917; 24.238	Conducted Out of Band Emissions	PASS	N/A
2.1051; 2.1057; 22.917; 24.238	Band Edge	PASS	N/A
22.913; 24.238	Transmitter Radiated Power (EIRP/ERP)	PASS	N/A
2.1053; 2.1057; 22.917; 24.238	Radiated Out of Band Emissions	PASS	N/A
Note: N/A is an abbreviation for Not Applicable.			

3. Test Equipment

AC Main Conducted Emission					
Description	Manufacturer	Model No.	Serial No.	Cal. Date	Cal. Due Date
EMI Test Receiver	ROHDE& SCHWARZ	ESCI	100321	Jul. 22, 2016	Jul. 21, 2017
50ΩCoaxial Switch	Anritsu	MP59B	X10321	Jul. 22, 2016	Jul. 21, 2017
L.I.S.N	Rohde & Schwarz	ENV216	101131	Jul. 22, 2016	Jul. 21, 2017
L.I.S.N	SCHWARZBECK	NNBL 8226-2	8226-2/164	Jul. 22, 2016	Jul. 21, 2017
Radiation Spurious Emission					
Description	Manufacturer	Model No.	Serial No.	Cal. Date	Cal. Due Date
Spectrum Analyzer	Agilent	E4407B	MY45106456	Jul. 22, 2016	Jul. 21, 2017
EMI Test Receiver	Rohde & Schwarz	ESCI	100010/007	Jul. 22, 2016	Jul. 21, 2017
Bilog Antenna	ETS-LINDGREN	3142E	00117537	Mar. 25, 2017	Mar. 24, 2018
Bilog Antenna	ETS-LINDGREN	3142E	00117542	Mar. 25, 2017	Mar. 24, 2018
Horn Antenna	ETS-LINDGREN	3117	00143207	Mar. 24, 2017	Mar. 23, 2018
Horn Antenna	ETS-LINDGREN	3117	00143209	Mar. 24, 2017	Mar. 23, 2018
Pre-amplifier	Sonoma	310N	185903	Mar. 24, 2017	Mar. 23, 2018
Pre-amplifier	HP	8449B	3008A00849	Mar. 25, 2017	Mar. 24, 2018
Cable	HUBER+SUHNER	100	SUCOFLEX	Mar. 24, 2017	Mar. 23, 2018
Signal Generator	Rohde & Schwarz	SML03	IKW682-054	Mar. 29, 2017	Mar. 28, 2018
Positioning Controller	ETS-LINDGREN	2090	N/A	N/A	N/A
Universal Radio Communication Tester	Rohde&Schwarz	CMU200	103903	Jun.21, 2017	Jun.22, 2018
Antenna Conducted Emission					
Description	Manufacturer	Model No.	Serial No.	Cal. Date	Cal. Due Date
Spectrum Analyzer	Agilent	E4407B	MY45106456	Jul. 22, 2016	Jul. 21, 2017
Spectrum Analyzer	Rohde & Schwarz	ESCI	100321	Jul. 22, 2016	Jul. 21, 2017
Universal Radio Communication Tester	Rohde&Schwarz	CMU200	103903	Jun.21, 2017	Jun.22, 2018

4. Frequency Stability

4.1 Test Standard and Requirement

4.1.1 Test Standard

FCC Part 2.1055

FCC Part 22.355

FCC Part 24.235

4.1.2 Requirement

According to FCC section 22.355 and FCC section 24.235, the frequency stability shall be sufficient to ensure that the fundamental emission stays within the authorized frequency block. According to FCC section 2.1055, the test conditions are:

(1) Temperature:

The temperature is varied from -30°C to $+50^{\circ}\text{C}$ at intervals of not more than 10°C .

(2) Primary Supply Voltage:

For hand carried battery powered equipment, the primary supply voltage is reduced to the battery operating end point which shall be specified by the manufacture. The supply voltage shall be measured at input to the cable normally provide with the equipment, or at the power supply terminals if cables are not normally provided.

4.2 Test Setup

For Temperature Test:

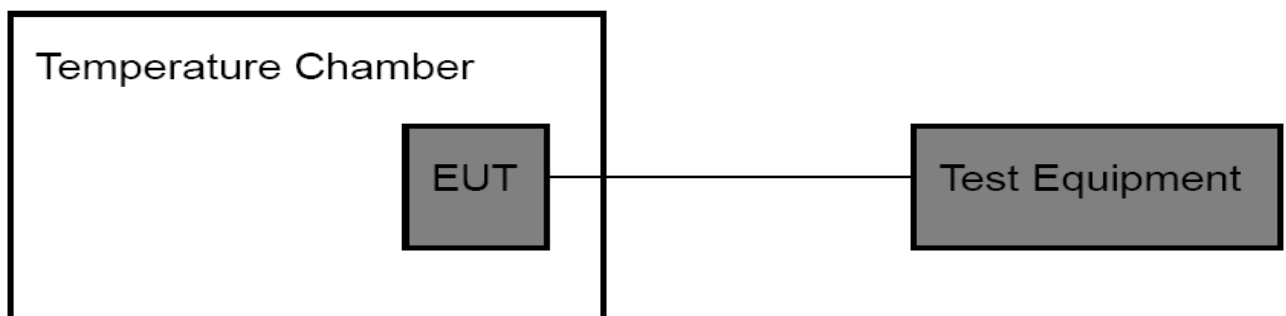

For Voltage Test:

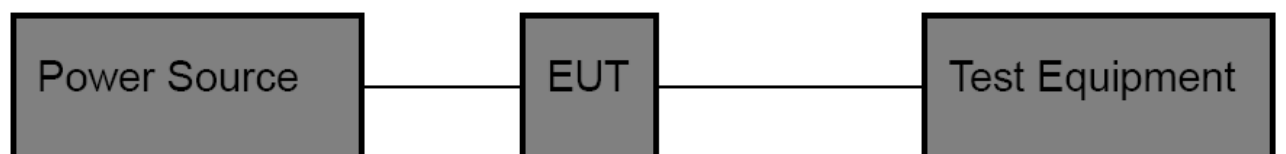

4.3 Test Procedure

Test Procedures for Temperature Variation:

- (1) The EUT was set up in the thermal chamber and connected with the base station.
- (2) With power off, the temperature was decreased to -30°C and the EUT was stabilized for three hours. Power was applied and the maximum change in frequency was recorded within one minute.
- (3) With power off, the temperature was raised in 10°C set up to 50°C and the EUT was stabilized for three hours. Power was applied and the maximum change in frequency was recorded within one minute.
- (4) If the EUT cannot be turned on at -30°C , the testing lowest temperature will be raised in 10°C step until the EUT can be turned on.

Test Procedures for Voltage Variation:

- (1) The EUT was placed in a temperature chamber at $25 \pm 5^{\circ}\text{C}$ and connected with the base station.
- (2) Reduce the input voltage to specify extreme voltage variation ($\pm 15\%$) and endpoint, record the maximum frequency change.
- (3) The variation in frequency was measured for the worst case.

4.4 EUT Operating Condition

The Equipment Under Test was set to Communication with the Base Station.

3.5 Test Data

Please refer the following pages.

Temperature Variation

Temperature Variation GSM 850 (CH190)						
Temperature (°C)	GSM		GPRS		EDGE	
	Freq. Dev. (Hz)	Deviation (ppm)	Freq. Dev. (Hz)	Deviation (ppm)	Freq. Dev. (Hz)	Deviation (ppm)
-30	4	0.005	2	0.002	4	0.005
-20	2	0.002	4	0.005	3	0.004
-10	3	0.004	5	0.006	5	0.006
0	6	0.007	2	0.002	2	0.002
10	5	0.006	1	0.001	3	0.004
20	2	0.002	5	0.006	2	0.002
30	6	0.007	4	0.005	3	0.004
40	5	0.006	3	0.004	2	0.002
50	4	0.005	2	0.002	1	0.001
60	3	0.004	4	0.005	3	0.004
Limit	2.5 (ppm)					
Result	PASS					

Temperature Variation GSM 1900 (CH661)						
Temperature (°C)	GSM		GPRS		EDGE	
	Freq. Dev. (Hz)	Deviation (ppm)	Freq. Dev. (Hz)	Deviation (ppm)	Freq. Dev. (Hz)	Deviation (ppm)
-30	9	0.011	8	0.010	4	0.005
-20	11	0.013	4	0.005	3	0.004
-10	10	0.012	5	0.006	5	0.006
0	6	0.007	7	0.008	7	0.008
10	7	0.008	8	0.010	3	0.004
20	9	0.011	6	0.007	8	0.010
30	6	0.007	4	0.005	7	0.008
40	8	0.010	6	0.007	4	0.005
50	4	0.005	9	0.011	5	0.006
60	7	0.008	5	0.006	3	0.004
Limit	2.5 (ppm)					
Result	PASS					

Temperature Variation UMTS Band V (CH 4183)		
Temperature (°C)	RMC Mode	
	Freq. Dev. (Hz)	Deviation (ppm)
-30	13	0.016
-20	11	0.013
-10	14	0.017
0	13	0.016
10	14	0.017
20	16	0.019
30	11	0.013
40	14	0.017
50	13	0.016
60	12	0.014
Limit	2.5 (ppm)	
Result	PASS	

Temperature Variation UMTS Band II (CH 9400)		
Temperature (°C)	RMC Mode	
	Freq. Dev. (Hz)	Deviation (ppm)
-30	10	0.005
-20	12	0.006
-10	18	0.010
0	11	0.006
10	15	0.008
20	13	0.007
30	10	0.005
40	15	0.008
50	12	0.006
60	11	0.006
Limit	2.5 (ppm)	
Result	PASS	

Voltage Variation

Voltage Variation GSM 850 (CH190)						
Voltage (V)	GSM		GPRS		EDGE	
	Freq. Dev. (Hz)	Deviation (ppm)	Freq. Dev. (Hz)	Deviation (ppm)	Freq. Dev. (Hz)	Deviation (ppm)
3.15	6	0.007	9	0.011	8	0.010
3.80	8	0.010	6	0.007	5	0.006
4.26	7	0.008	8	0.010	7	0.008
Limit	2.5 (ppm)					
Result	PASS					

Voltage Variation GSM 1900 (CH661)						
Voltage (V)	GSM		GPRS		EDGE	
	Freq. Dev. (Hz)	Deviation (ppm)	Freq. Dev. (Hz)	Deviation (ppm)	Freq. Dev. (Hz)	Deviation (ppm)
3.15	5	0.008	5	0.008	6	0.009
3.80	3	0.005	4	0.006	8	0.012
4.26	6	0.009	7	0.011	9	0.014
Limit	2.5 (ppm)					
Result	PASS					

Voltage Variation UMTS Band V (CH 4182)		
Voltage (V)	RMC Mode	
	Freq. Dev. (Hz)	Deviation (ppm)
3.15	18	0.022
3.80	15	0.018
4.26	13	0.016
Limit	2.5 (ppm)	
Result	PASS	

Voltage Variation UMTS Band II (CH 9400)		
Voltage (V)	RMC Mode	
	Freq. Dev. (Hz)	Deviation (ppm)
3.15	14	0.007
3.80	12	0.006
4.26	13	0.007
Limit	2.5 (ppm)	
Result	PASS	

5. Conducted RF Output Power

5.1 Test Standard and Limit

5.1.1 Test Standard

FCC Part 2: 2.1046

FCC Part 22H : 22.913 (a)

FCC Part 24E: 24.232 (c)

5.1.2 Test Limit

GSM850/UMTS Band V	PCS 1900/UMTS Band II
38.5 dBm (ERP)	33 dBm (EIRP)

5.2 Test Setup

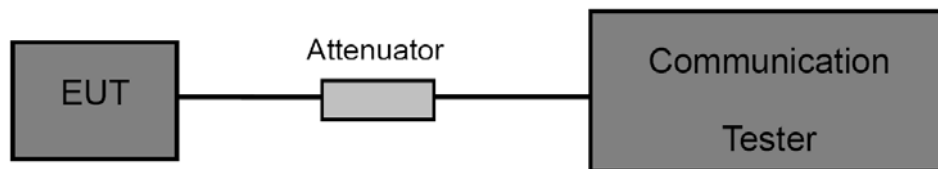

5.3 Test Procedure

- (1) The EUT is coupled to the Base Station with the suitable Attenuator, the path loss is calibrated to correct the reading.
- (2) A call is set up by the Base Station to the generic call set up procedure.
- (3) Set EUT at maximum power level through base station by power level command.
- (4) Then read record the power value from the Base Station in dBm.

5.4 EUT Operating Condition

The EUT was continuously connected with the Base station and transmitting in the max power during the test.

5.5 EUT Operating Condition

GSM 850				
Mode	Channel	Frequency (MHz)	Conducted Power (dBm)	Conducted Power (W)
GSM 850	128	824.2	32.93	1.963
	190	836.6	32.92	1.959
	251	848.8	32.95	1.972
GPRS 850 (1 Slot)	128	824.2	31.96	1.570
	190	836.6	31.98	1.578
	251	848.8	31.97	1.574
GPRS 850 (2 Slot)	128	824.2	30.23	1.054
	190	836.6	30.42	1.102
	251	848.8	30.52	1.127
GPRS 850 (3 Slot)	128	824.2	29.16	0.824
	190	836.6	29.26	0.843
	251	848.8	29.34	0.859
GPRS 850 (4 Slot)	128	824.2	28.47	0.703
	190	836.6	28.32	0.679
	251	848.8	28.41	0.693
EDGE 850 (1 Slot)	128	824.2	25.76	0.377
	190	836.6	25.68	0.370
	251	848.8	25.58	0.361
EDGE 850 (2 Slot)	128	824.2	24.56	0.286
	190	836.6	24.38	0.274
	251	848.8	24.46	0.279
EDGE 850 (3 Slot)	128	824.2	23.69	0.234
	190	836.6	23.58	0.228
	251	848.8	23.72	0.236
EDGE 850 (4 Slot)	128	824.2	22.59	0.182
	190	836.6	22.63	0.183
	251	848.8	22.75	0.188

PCS 1900				
Mode	Channel	Frequency (MHz)	Conducted Power (dBm)	Conducted Power (W)
GSM 1900	512	1850.2	29.59	0.910
	661	1880.0	29.24	0.839
	810	1909.8	29.58	0.908
GPRS 1900 (1 Slot)	512	1850.2	28.58	0.721
	661	1880.0	28.20	0.661
	810	1909.8	28.96	0.787
GPRS 1900 (2 Slot)	512	1850.2	27.57	0.571
	661	1880.0	27.63	0.579
	810	1909.8	27.75	0.596
GPRS 1900 (3 Slot)	512	1850.2	26.37	0.434
	661	1880.0	26.45	0.442
	810	1909.8	26.44	0.441
GPRS 1900 (4 Slot)	512	1850.2	25.14	0.327
	661	1880.0	25.22	0.333
	810	1909.8	25.31	0.340
EDGE 1900 (1 Slot)	512	1850.2	27.20	0.525
	661	1880.0	27.22	0.527
	810	1909.8	27.32	0.540
EDGE 1900 (2 Slot)	512	1850.2	26.11	0.408
	661	1880.0	26.08	0.406
	810	1909.8	26.23	0.420
EDGE 1900 (3 Slot)	512	1850.2	25.09	0.323
	661	1880.0	25.17	0.329
	810	1909.8	25.12	0.325
EDGE 1900 (4 Slot)	512	1850.2	24.33	0.271
	661	1880.0	24.19	0.262
	810	1909.8	24.24	0.265

UMTS Band V				
Mode	Channel	Frequency (MHz)	Conducted Power (dBm)	Conducted Power (W)
Band V RMC	4132	826.4	22.67	0.185
	4183	836.6	22.69	0.186
	4233	846.6	22.87	0.194
HSDPA Subtest 1	4132	826.4	22.06	0.161
	4183	836.6	22.09	0.162
	4233	846.6	22.12	0.163
HSDPA Subtest 2	4132	826.4	21.87	0.154
	4183	836.6	21.96	0.157
	4233	846.6	21.78	0.151
HSDPA Subtest 3	4132	826.4	21.45	0.140
	4183	836.6	21.34	0.136
	4233	846.6	21.14	0.130
HSDPA Subtest 4	4132	826.4	20.58	0.114
	4183	836.6	20.69	0.117
	4233	846.6	20.87	0.122
HSUPA Subtest 1	4132	826.4	22.21	0.166
	4183	836.6	22.24	0.167
	4233	846.6	22.18	0.165
HSUPA Subtest 2	4132	826.4	21.89	0.155
	4183	836.6	21.76	0.150
	4233	846.6	21.68	0.147
HSUPA Subtest 3	4132	826.4	20.98	0.125
	4183	836.6	20.97	0.125
	4233	846.6	20.87	0.122
HSUPA Subtest 4	4132	826.4	20.54	0.113
	4183	836.6	20.63	0.116
	4233	846.6	20.57	0.114
HSUPA Subtest 5	4132	826.4	20.23	0.105
	4183	836.6	20.41	0.110
	4233	846.6	20.46	0.111

UMTS Band II				
Mode	Channel	Frequency (MHz)	Conducted Power (dBm)	Conducted Power (W)
Band II RMC	9262	1852.4	22.43	0.175
	9400	1880.0	22.32	0.171
	9538	1907.6	22.09	0.162
HSDPA Subtest 1	9262	1852.4	20.00	0.100
	9400	1880.0	19.81	0.096
	9538	1907.6	19.87	0.097
HSDPA Subtest 2	9262	1852.4	19.68	0.093
	9400	1880.0	19.75	0.094
	9538	1907.6	19.84	0.096
HSDPA Subtest 3	9262	1852.4	19.45	0.088
	9400	1880.0	19.36	0.086
	9538	1907.6	19.43	0.088
HSDPA Subtest 4	9262	1852.4	19.38	0.087
	9400	1880.0	19.41	0.087
	9538	1907.6	19.37	0.086
HSUPA Subtest 1	9262	1852.4	19.10	0.081
	9400	1880.0	19.12	0.082
	9538	1907.6	19.21	0.083
HSUPA Subtest 2	9262	1852.4	20.98	0.125
	9400	1880.0	20.92	0.124
	9538	1907.6	20.88	0.122
HSUPA Subtest 3	9262	1852.4	20.13	0.103
	9400	1880.0	20.08	0.102
	9538	1907.6	20.14	0.103
HSUPA Subtest 4	9262	1852.4	19.98	0.100
	9400	1880.0	19.89	0.097
	9538	1907.6	19.94	0.099
HSUPA Subtest 5	9262	1852.4	19.24	0.084
	9400	1880.0	19.32	0.086
	9538	1907.6	19.47	0.089

6. Peak-Average Ratio

6.1 Test Standard and Limit

6.1.1 Test Standard

FCC Part 24E: 24.232 (d)

6.1.2 Test Limit

PCS 1900 /UMTS Band II

The peak-to-average ratio (PAR) of the transmission may not exceed 13 dB.

6.2 Test Setup

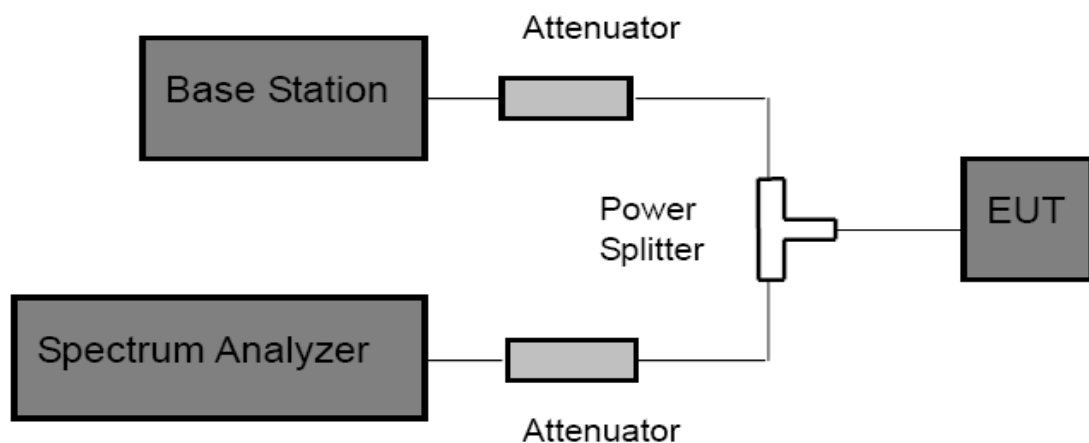

6.3 Test Procedure

According with KDB 971168

- (1) The signal analyzer's CCDF measurement profile is enabled.
- (2) Frequency = carrier center frequency.
- (3) Measurement BW > Emission bandwidth of signal.
- (4) The signal analyzer was set to collect one million samples to generate the CCDF curve.
- (5) The measurement interval was set depending on the type of signal analyzed. For continuous signals (>98% duty cycle), the measurement interval was set to 1ms. For burst transmissions, the spectrum analyzer is set to use an internal "RF Burst" trigger that is synced with an incoming pulse and the measurement interval is set to less than the duration of the "on time" of one burst to ensure that energy is only captured during a time in which of the transmitter is operating at maximum power.

6.4 EUT Operating Condition

The EUT was continuously connected with the Base station and transmitting in the max power

during the test.

6.5 Test Data

PCS 1900			
Mode	Channel	Frequency (MHz)	Peak-Average Ratio (PAR)
PCS 1900	512	1850.2	0.020
	661	1880.0	0.035
	810	1909.8	0.006

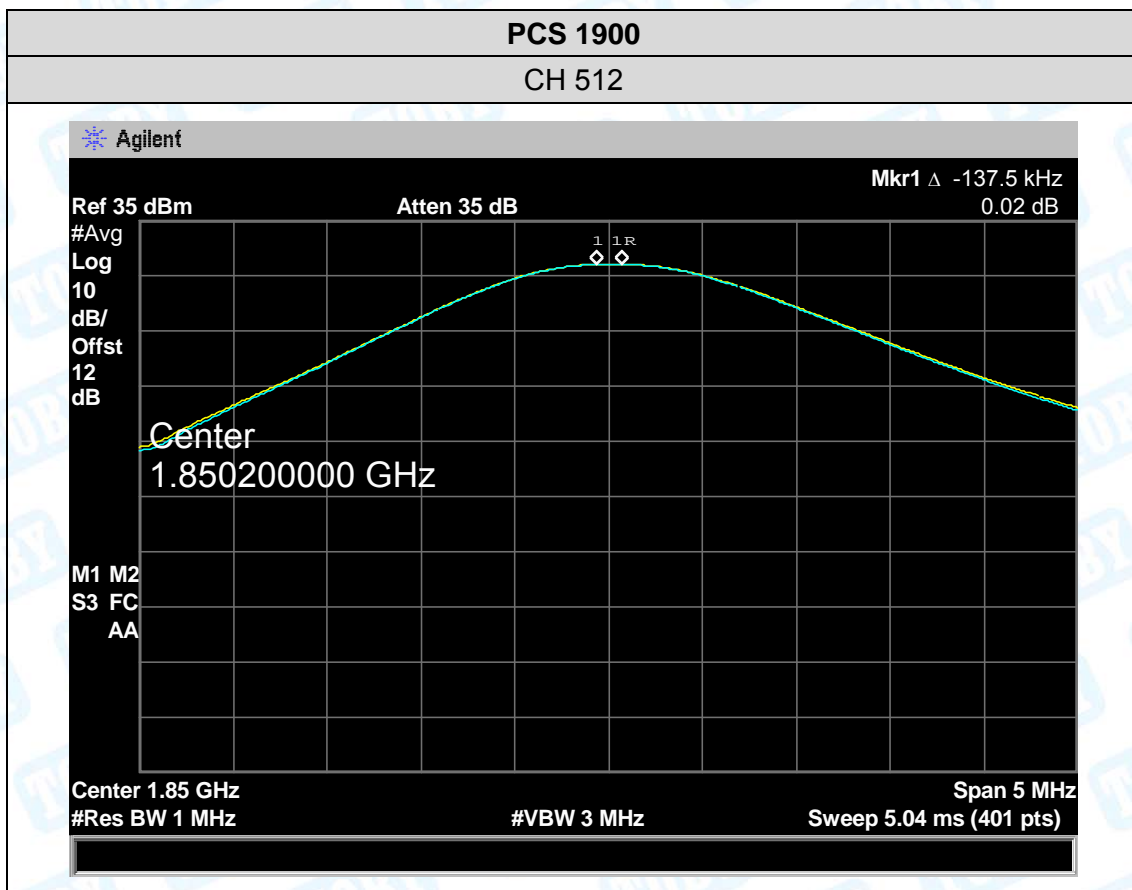

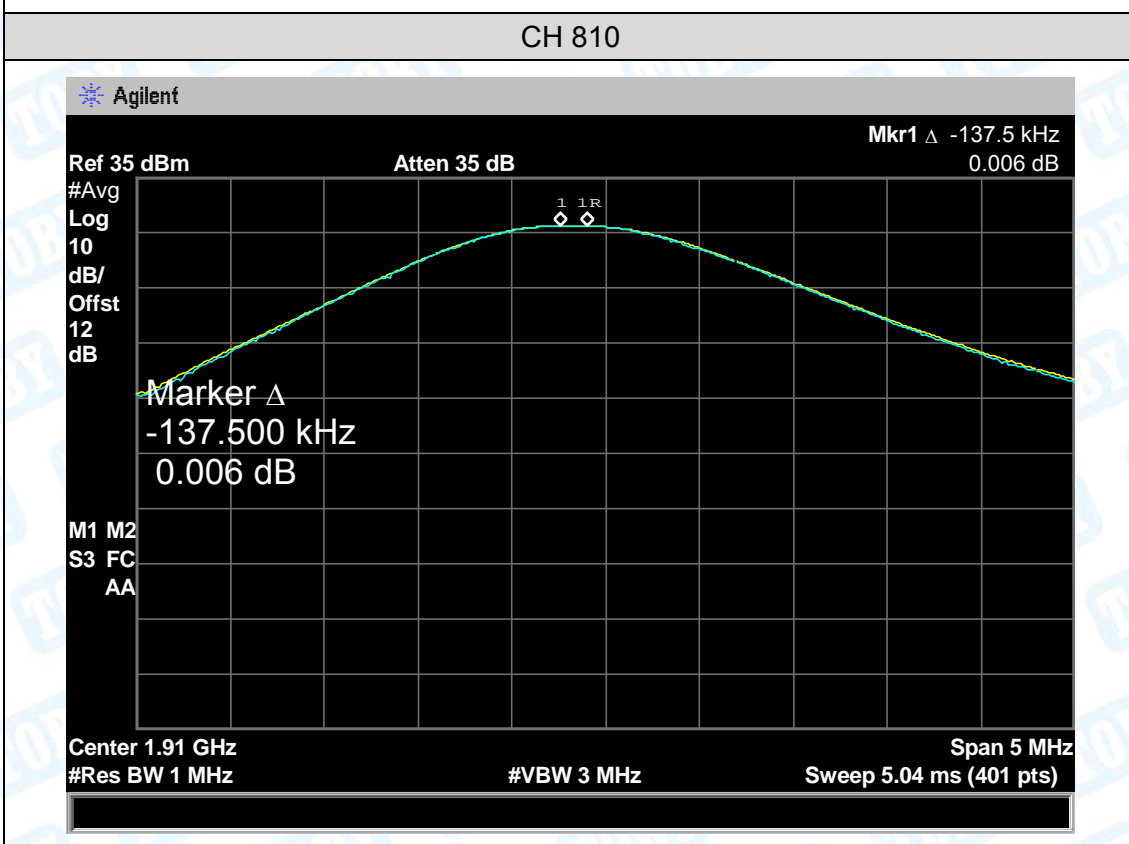
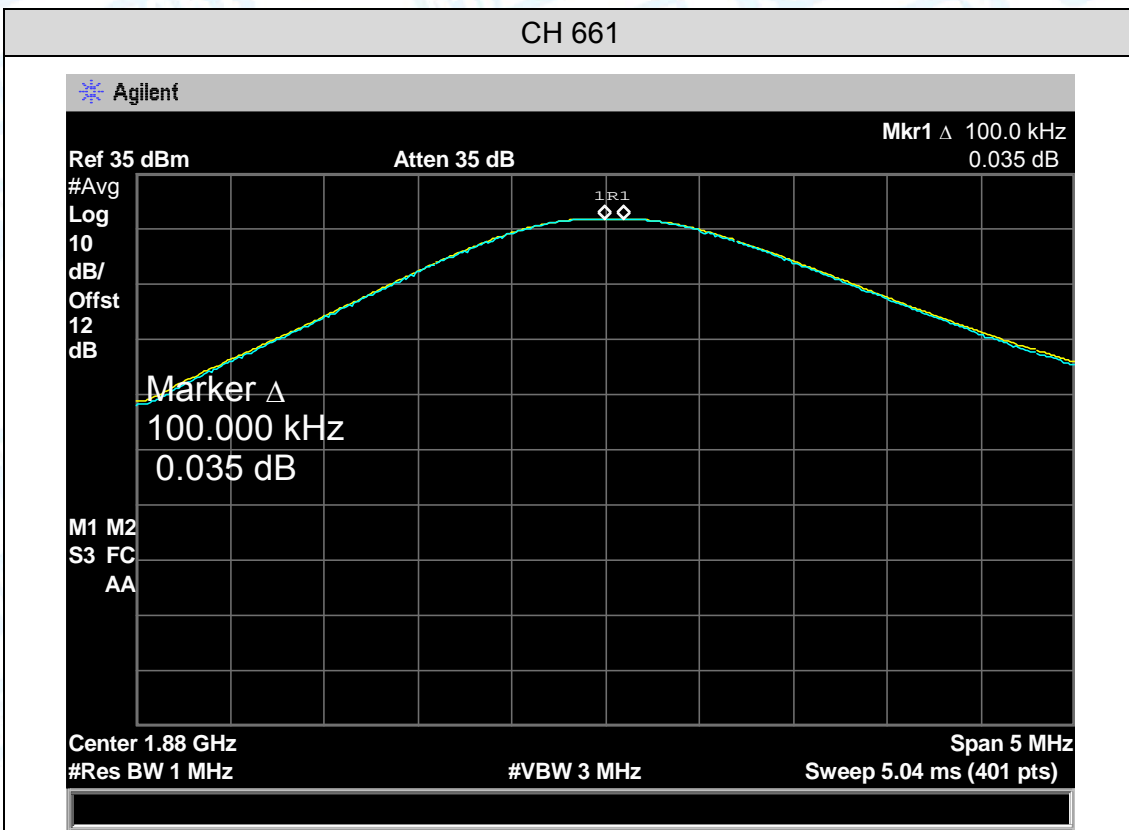

UMTS Band II			
Mode	Channel	Frequency (MHz)	Peak-Average Ratio (PAR)
UMTS Band II	9262	1852.4	3.18
	9400	1880.0	2.93
	9538	1907.6	2.69

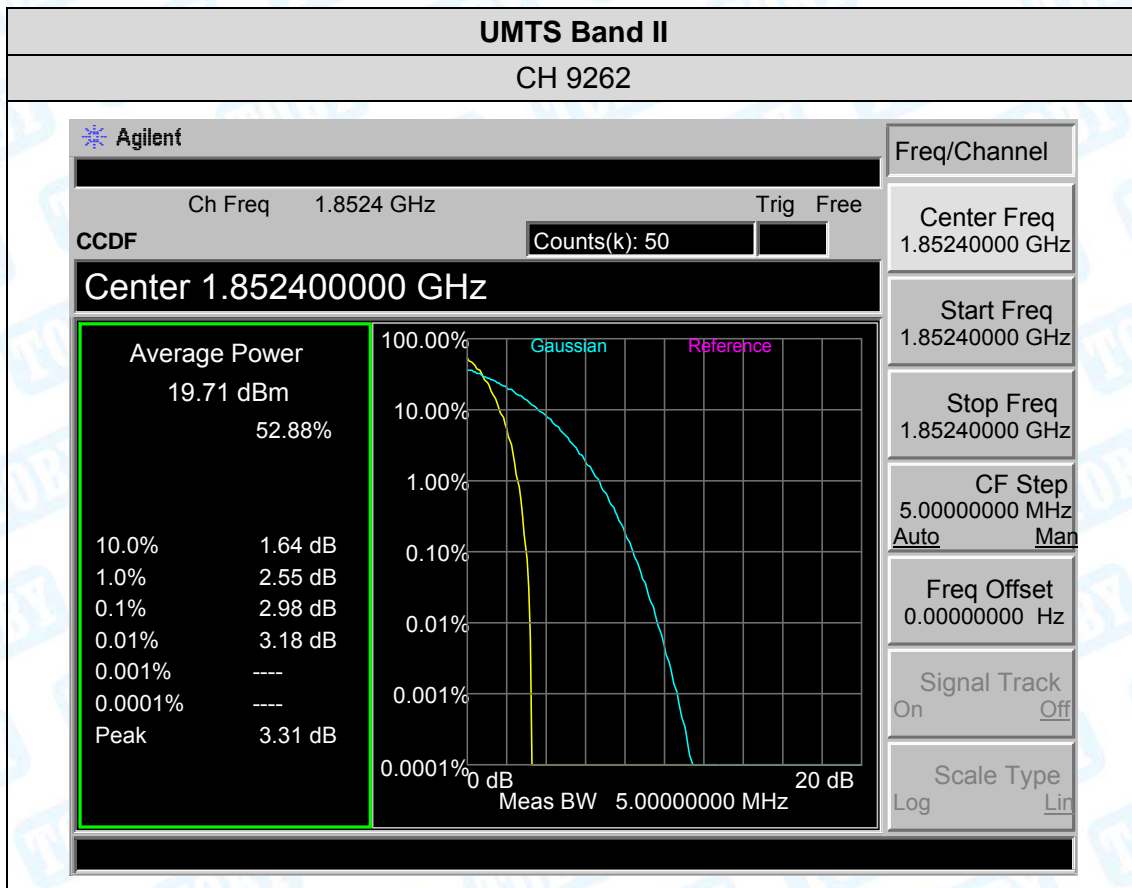

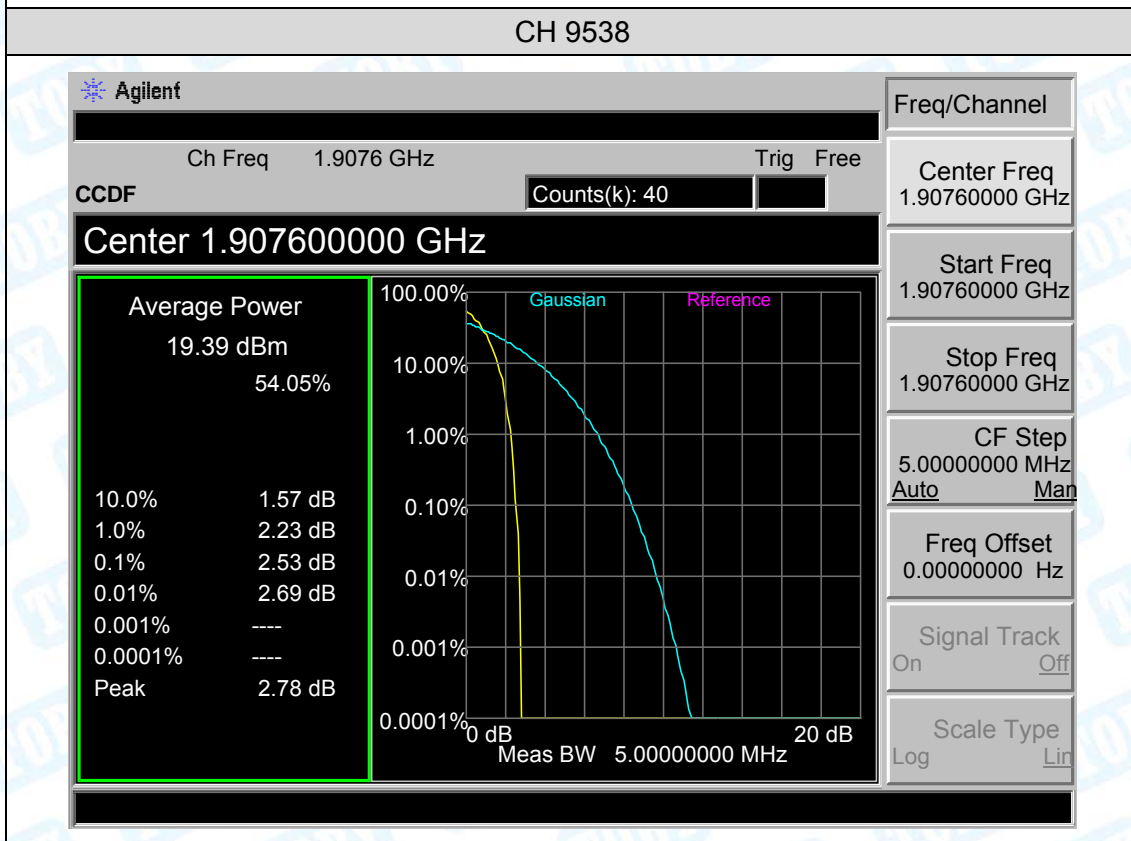
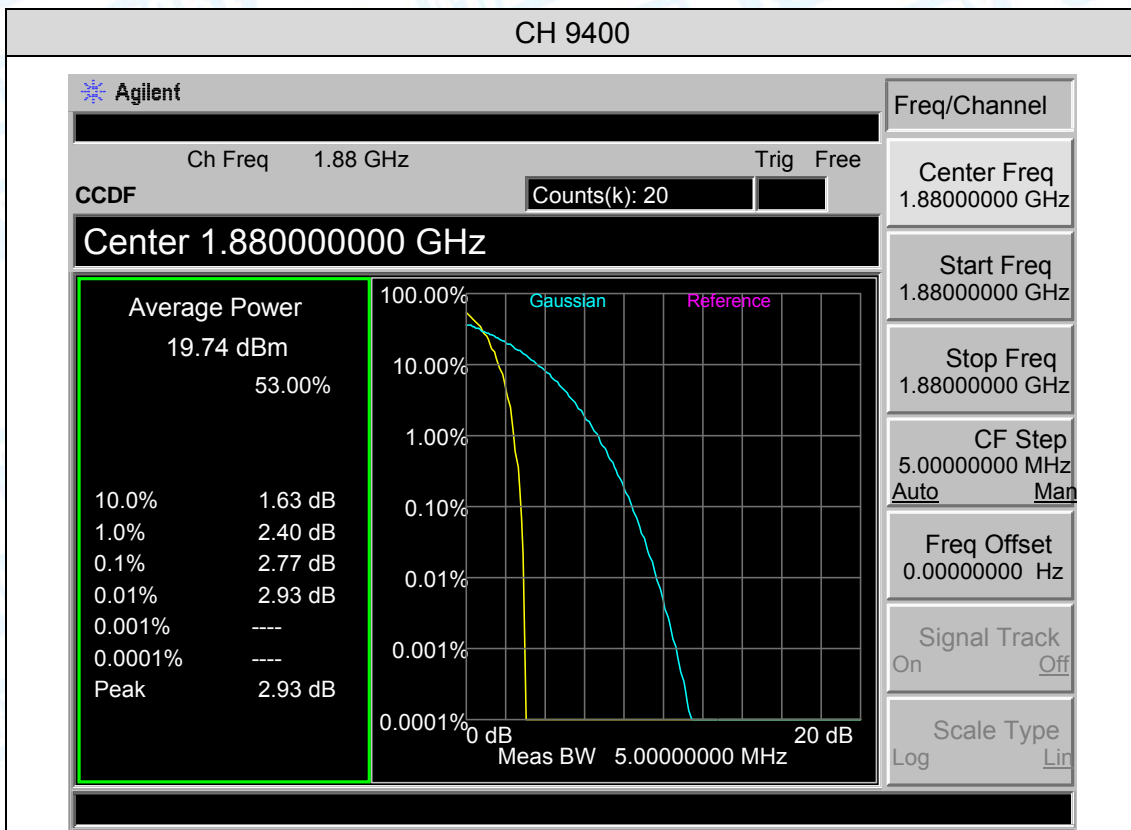

7. Radiated Output Power

7.1 Test Standard and Limit

7.1.1 Test Standard

FCC Part 22H : 22.913 (a)

FCC Part 24E: 24.232 (c)

7.1.2 Test Limit

According to FCC Part 22.913 (a), the ERP of Cellular mobile transmitters must not exceed 7 Watts(38.5 dBm).

According to FCC Part 24.232 (c), the Mobile/portable stations are limited to 2 Watts(33 dBm) EIRP peak power.

Cellular Band		PCS Band	
GSM850	UMTS Band V	PCS 1900	UMTS Band II
38.5 dBm (ERP)		33 dBm (EIRP)	

7.2 Test Setup

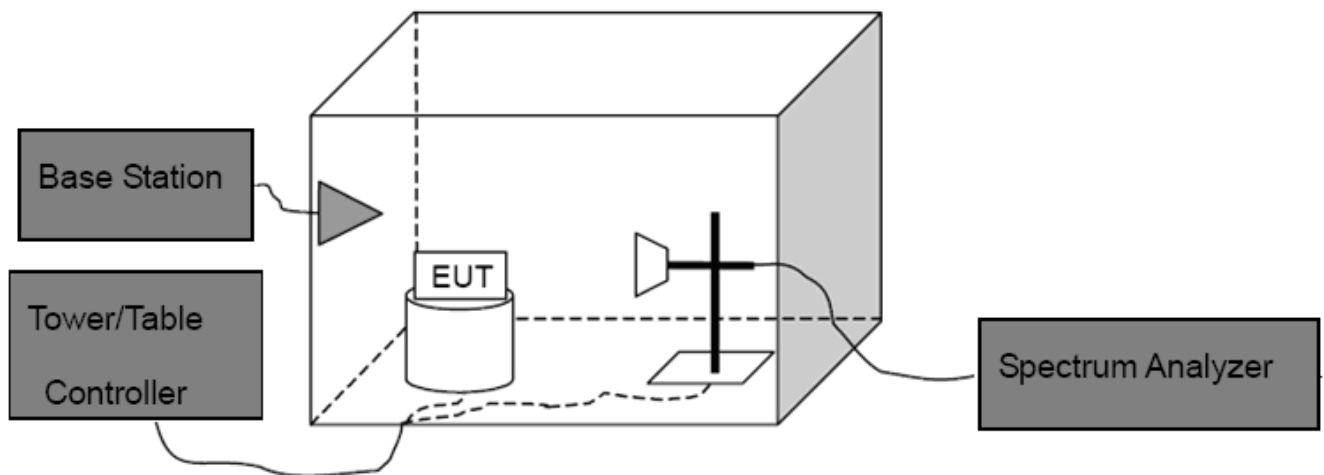

Above 1G

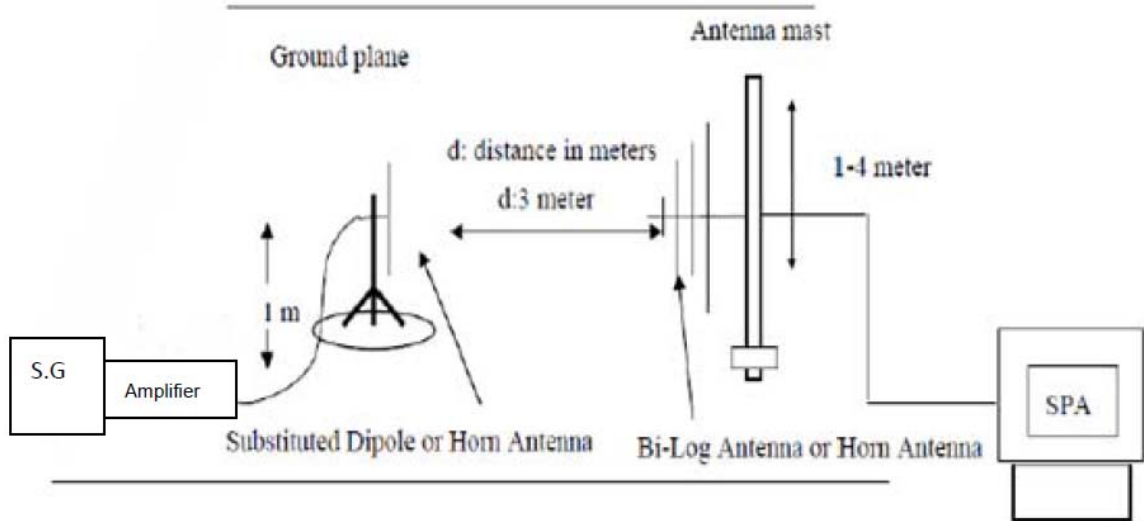

Substituted Method

7.3 Test Procedure

- (1) The EUT was placed on a non-conductive rotating platform with 0.8 meter height in an anechoic chamber. The radiated emission at the fundamental frequency was measured at 3 m with a test antenna and a spectrum analyzer with RBW=3 MHz, VBW=3 MHz and peak detector settings.
- (2) During the measurement, the EUT was enforced in maximum power and linked with the Base Station. The highest was recorded from analyzer power level (LVT) from the 360 degrees rotation of the turntable and the test antenna raised and lowered over a range from 1 to 4 meters in both horizontally and vertically polarized orientations.
- (3) Effective Isotropic Radiated Power (EIRP) was measured by substitution method according to C63.26. The EUT was replaced by dipole antenna (for frequency below 1 GHz) or Horn antenna (for frequency above 1 GHz) at same location with same polarize of receiver antenna and then a known power of each measure frequency from S.G. was applied into the dipole antenna or Horn antenna through a TX cable, and then recorded the maximum Analyzer reading through raised and lowered the test antenna.

Note: In test, the S.G. Connect the Pre-amplifier (Sonoma 310N Pre-amplifier for frequency below 1 GHz, HP 8449B Pre-amplifier for frequency above 1 GHz)

Then the EUT's EIRP and ERP was calculated with the correction factor:
 $ERP = S.G. Level + Antenna Gain Cord. (dBd) - Cable Loss (dB)$
 $EIRP = S.G. Level + Antenna Gain Cord. (dBi) - Cable Loss (dB)$

7.4 EUT Operating Condition

The EUT was continuously connected with the Base station and transmitting in the max power during the test.

7.5 Test Data

Measurement Data (worst case)

GSM 850								
Mode	Channel	Frequency (MHz)	Antenna (H&V)	SG Level (dBm)	Antenna Factor (dBd)	Cable Loss (dB)	ERP Power (dBm)	ERP Power (W)
GSM 850	128	824.2	H	29.78	3.46	1.26	31.98	1.578
			V	26.47	3.46	1.26	28.67	0.736
	190	836.6	H	29.43	3.82	1.26	31.99	1.581
			V	25.89	3.82	1.26	28.45	0.700
	251	848.8	H	28.14	4.16	1.26	31.04	1.271
			V	25.74	4.16	1.26	28.64	0.731
GPRS 850 (1 Slot)	128	824.2	H	27.47	3.46	1.26	29.67	0.927
			V	23.11	3.46	1.26	25.31	0.340
	190	836.6	H	27.31	3.82	1.26	29.87	0.971
			V	22.90	3.82	1.26	25.46	0.352
	251	848.8	H	26.46	4.16	1.26	29.36	0.863
			V	22.31	4.16	1.26	25.21	0.332
EDGE 850 (1 Slot)	128	824.2	H	22.16	3.46	1.26	24.36	0.273
			V	19.34	3.46	1.26	21.54	0.143
	190	836.6	H	22.09	3.82	1.26	24.65	0.292
			V	18.67	3.82	1.26	21.23	0.133
	251	848.8	H	21.68	4.16	1.26	24.58	0.287
			V	18.42	4.16	1.26	21.32	0.136
Limit							38.5	7

PCS 1900								
Mode	Channel	Frequency (MHz)	Antenna (H&V)	SG Level (dBm)	Antenna Factor (dBi)	Cable Loss (dB)	EIRP Power (dBm)	EIRP Power (W)
GSM 1900	512	1850.2	H	26.79	5.01	2.59	29.21	0.834
			V	24.12	5.01	2.59	26.54	0.451
	661	1880.0	H	26.95	4.82	2.59	29.18	0.828
			V	24.18	4.82	2.59	26.41	0.438
	810	1909.8	H	27.10	4.45	2.59	28.96	0.787
			V	24.25	4.45	2.59	26.11	0.408
GPRS 1900 (1 Slot)	512	1850.2	H	25.23	5.01	2.59	27.65	0.582
			V	22.25	5.01	2.59	24.67	0.293
	661	1880.0	H	25.64	4.82	2.59	27.87	0.612
			V	22.13	4.82	2.59	24.36	0.273
	810	1909.8	H	25.55	4.45	2.59	27.41	0.551
			V	22.38	4.45	2.59	24.24	0.265
EDGE 1900 (1 Slot)	512	1850.2	H	23.83	5.01	2.59	26.25	0.422
			V	21.12	5.01	2.59	23.54	0.226
	661	1880.0	H	24.25	4.82	2.59	26.48	0.445
			V	21.39	4.82	2.59	23.62	0.230
	810	1909.8	H	24.80	4.45	2.59	26.66	0.463
			V	21.55	4.45	2.59	23.41	0.219
Limit							33	2

UMTS Band V								
Mode	Channel	Frequency (MHz)	Antenna (H&V)	SG Level (dBm)	Antenna Factor (dBi)	Cable Loss (dB)	EIRP Power (dBm)	EIRP Power (W)
Band V RMC	4132	826.4	H	19.75	3.46	1.26	21.95	0.157
			V	16.49	3.46	1.26	18.69	0.074
	4183	836.6	H	19.30	3.82	1.26	21.86	0.154
			V	16.19	3.82	1.26	18.75	0.075
	4233	846.6	H	18.87	4.16	1.26	21.77	0.150
			V	15.69	4.16	1.26	18.59	0.072
Limit							38.5	7

UMTS Band II								
Mode	Channel	Frequency (MHz)	Antenna (H&V)	SG Level (dBm)	Antenna Factor (dBi)	Cable Loss (dB)	EIRP Power (dBm)	EIRP Power (W)
Band II RMC	9262	1852.4	H	19.26	5.01	2.59	21.68	0.147
			V	15.90	5.01	2.59	18.32	0.068
	9400	1880.0	H	19.65	4.82	2.59	21.88	0.154
			V	16.61	4.82	2.59	18.84	0.077
	9538	1907.6	H	20.08	4.45	2.59	21.94	0.156
			V	16.96	4.45	2.59	18.82	0.076
Limit							33	2

8. Occupied Bandwidth

8.1 Test Standard and Limit

8.1.1 Test Standard

FCC Part 2: 2.1049

FCC Part 22H : 22.913 (a)

FCC Part 24E: 24.232 (c)

8.1.2 Test Requirement

According to FCC section 2.1049, the occupied bandwidth is the frequency bandwidth such that below its lower and above its upper frequency limits, the mean powers radiated are each equal to 0.5 percent of the total mean power radiated by a given emission.

Occupied bandwidth is also known as 99% power and -26dBC occupied bandwidths.

8.2 Test Setup

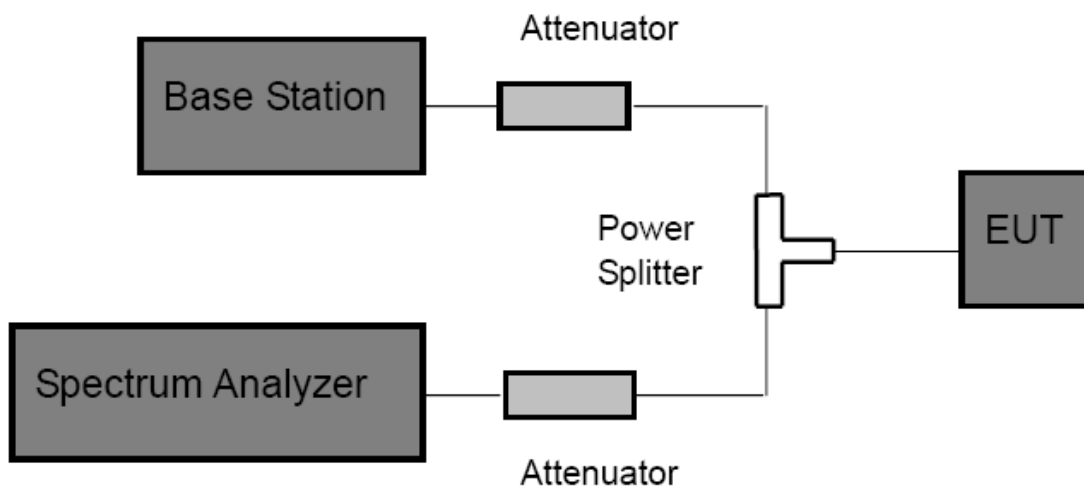

8.3 Test Procedure

- (1) The EUT was directly connected to the spectrum analyzer and Base station via power splitter as show in the block diagram above.
- (2) The resolution bandwidth of the Spectrum Analyzer is set to at least 1% of the occupied bandwidth.
- (3) The low, middle and the high channels are selected to perform tests respectively.
- (4) Set the frequency range of the Spectrum Analyzer suitably to capture the waveform; search peak; make a line whose value is 26dB lower than the peak; mark two points which the line intersected the waveform at; finally record the delta of the two points as the occupied bandwidth and the plot.
- (5) Set the Spectrum Analyzer Occupied bandwidth function to measure the 99% occupied bandwidth.

8.4 EUT Operating Condition

The EUT was continuously connected with the Base station and transmitting in the max power during the test.

8.5 Test Data

Please refer following pages.

GSM 850				
Mode	Channel	Frequency (MHz)	99% OBW (MHz)	-26dB Bandwidth (kHz)
GSM 850	128	824.2	242.7539	321.916
	190	836.6	245.8383	321.572
	251	848.8	247.8107	316.961
GPRS 850 (1 Slot)	128	824.2	246.7869	316.324
	190	836.6	243.2295	322.551
	251	848.8	243.2439	321.258
EDGE 850 (1 Slot)	128	824.2	244.0199	305.704
	190	836.6	242.7007	327.741
	251	848.8	236.3275	309.489
PCS 1900				
Mode	Channel	Frequency (MHz)	99% OBW (MHz)	-26dB Bandwidth (kHz)
GSM 1900	512	1850.2	242.2797	312.468
	661	1880.0	246.8607	322.236
	810	1909.8	245.6874	315.507
GPRS 1900 (1 Slot)	512	1850.2	252.4420	320.884
	661	1880.0	251.3553	320.392
	810	1909.8	248.1113	322.168
EDGE 1900 (1 Slot)	512	1850.2	255.8211	323.072
	661	1880.0	251.4893	328.710
	810	1909.8	253.2319	319.622

UMTS Band V				
Mode	Channel	Frequency (MHz)	99% OBW (MHz)	-26dB Bandwidth (MHz)
Band V RMC	4132	826.4	4.2083	4.875
	4183	836.6	4.2541	4.971
	4233	846.6	4.2290	4.942
Band V HSDPA	4132	826.4	4.1984	4.868
	4183	836.6	4.2244	4.931
	4233	846.6	4.2234	4.919
Band V HSUPA	4132	826.4	4.2009	4.884
	4183	836.6	4.2230	4.899
	4233	846.6	4.2290	4.928
UMTS Band II				
Mode	Channel	Frequency (MHz)	99% OBW (MHz)	-26dB Bandwidth (MHz)
Band II RMC	9262	1852.4	4.2203	4.876
	9400	1880.0	4.2048	4.872
	9538	1907.6	4.2127	4.899
Band II HSDPA	9262	1852.4	4.2096	4.904
	9400	1880.0	4.2175	4.912
	9538	1907.6	4.2138	4.864
Band II HSUPA	9262	1852.4	4.2041	4.878
	9400	1880.0	4.1922	4.896
	9538	1907.6	4.2116	4.870

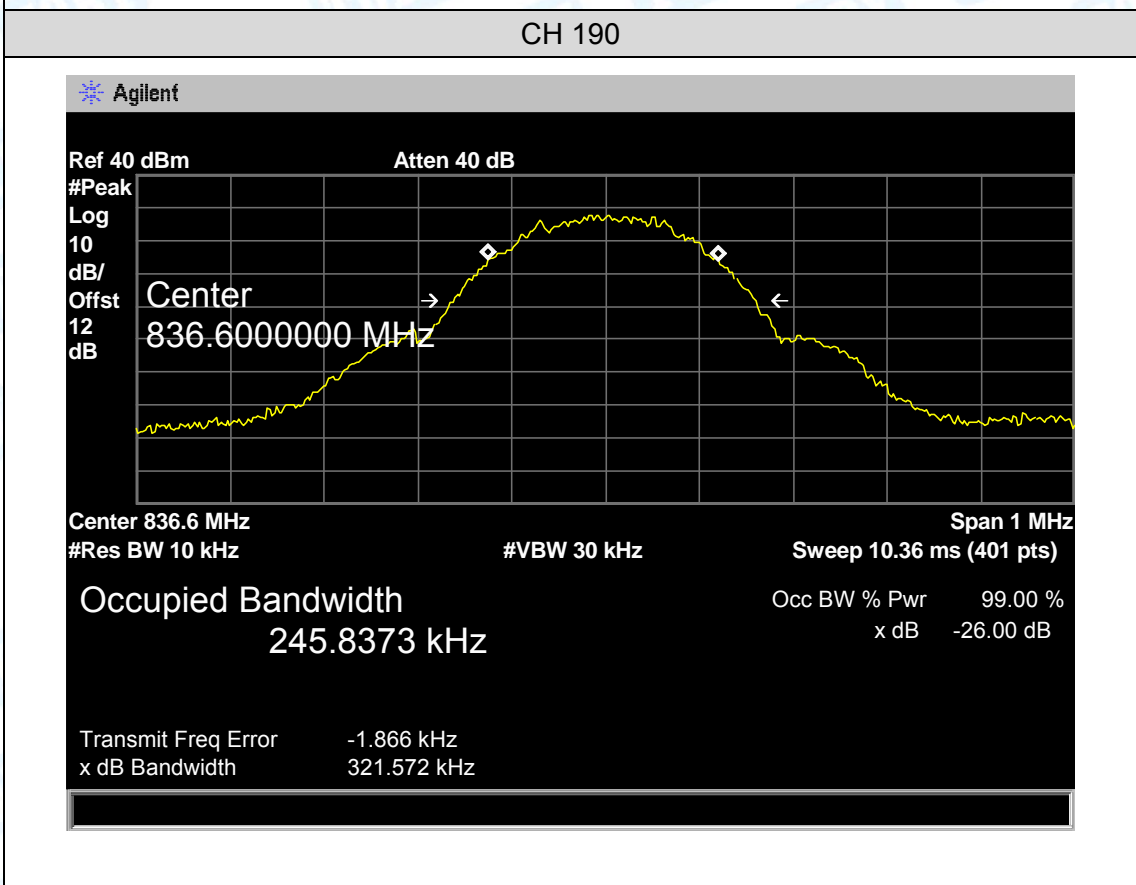
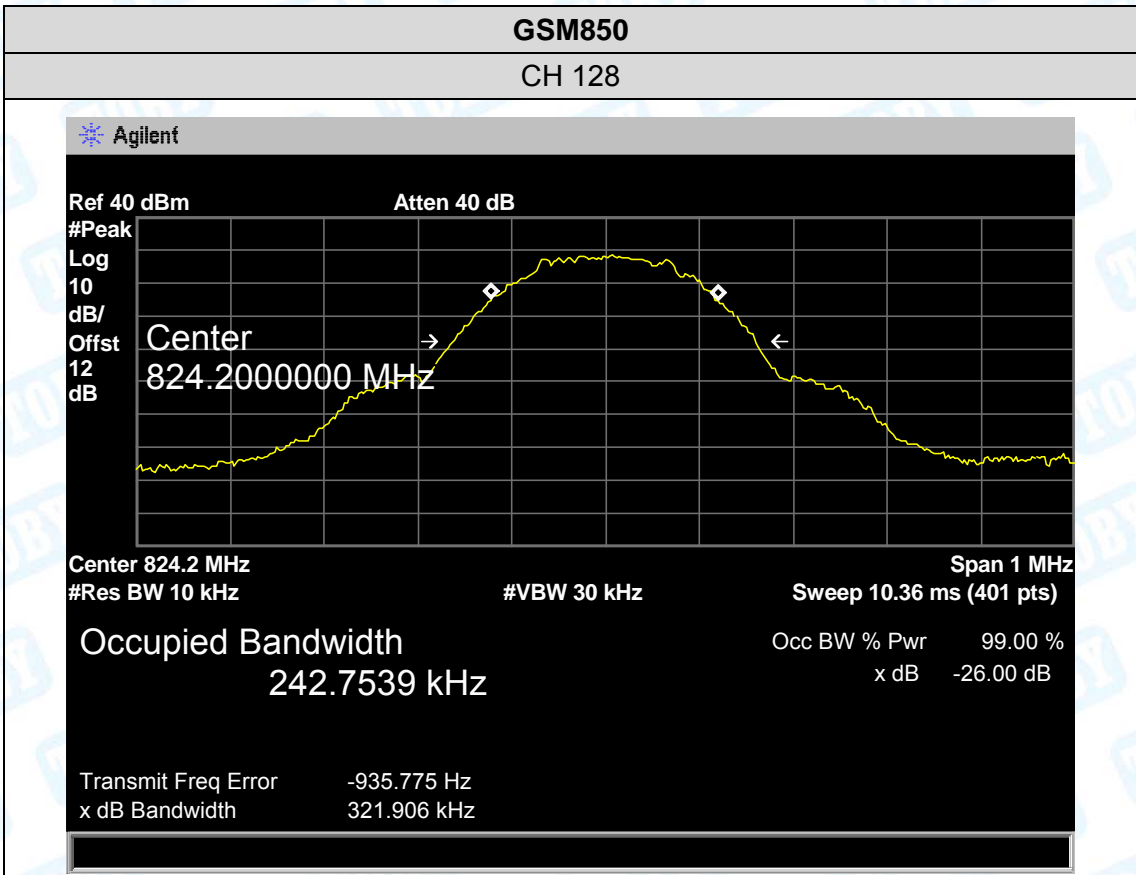

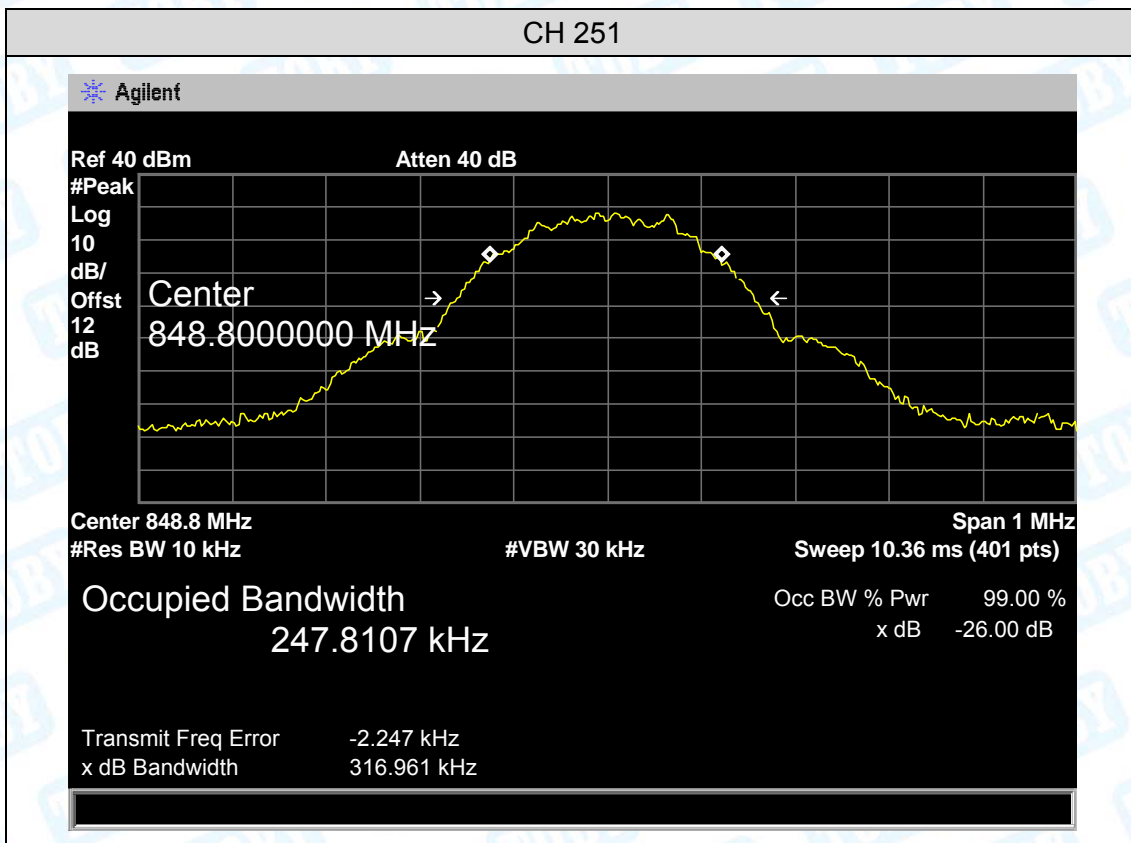

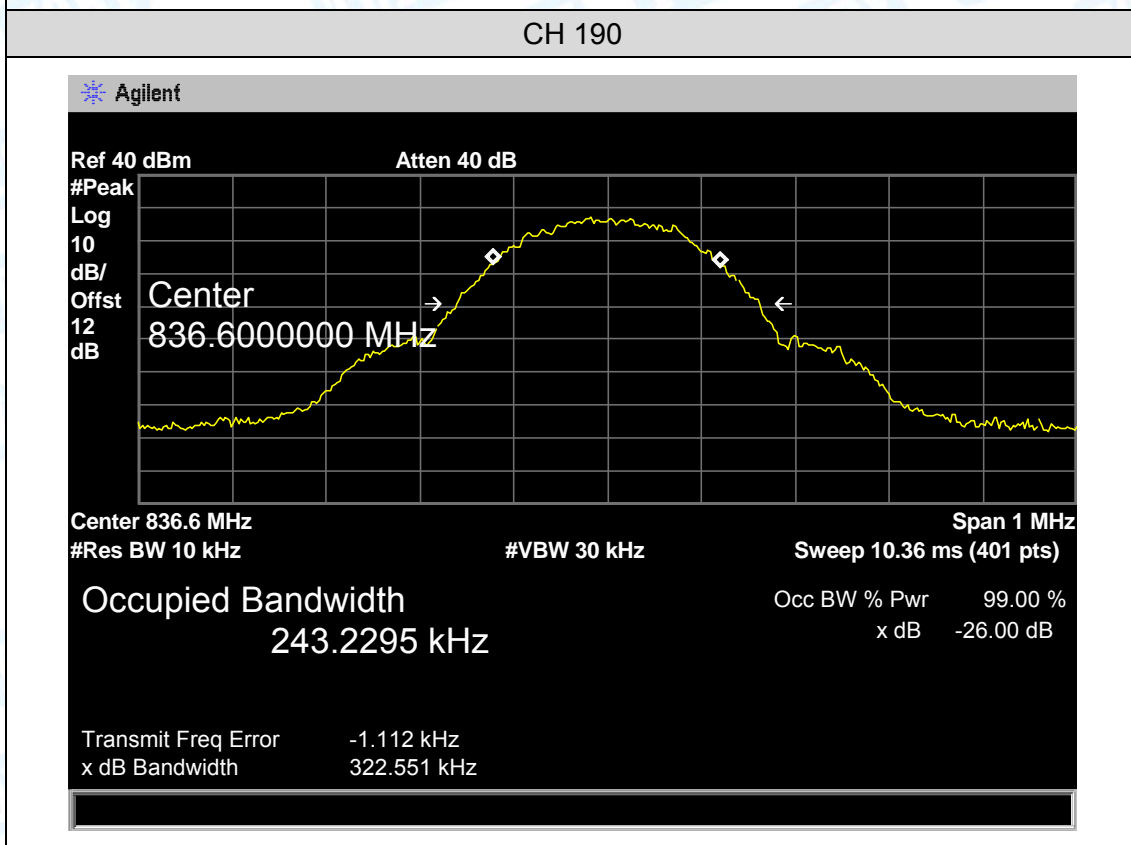
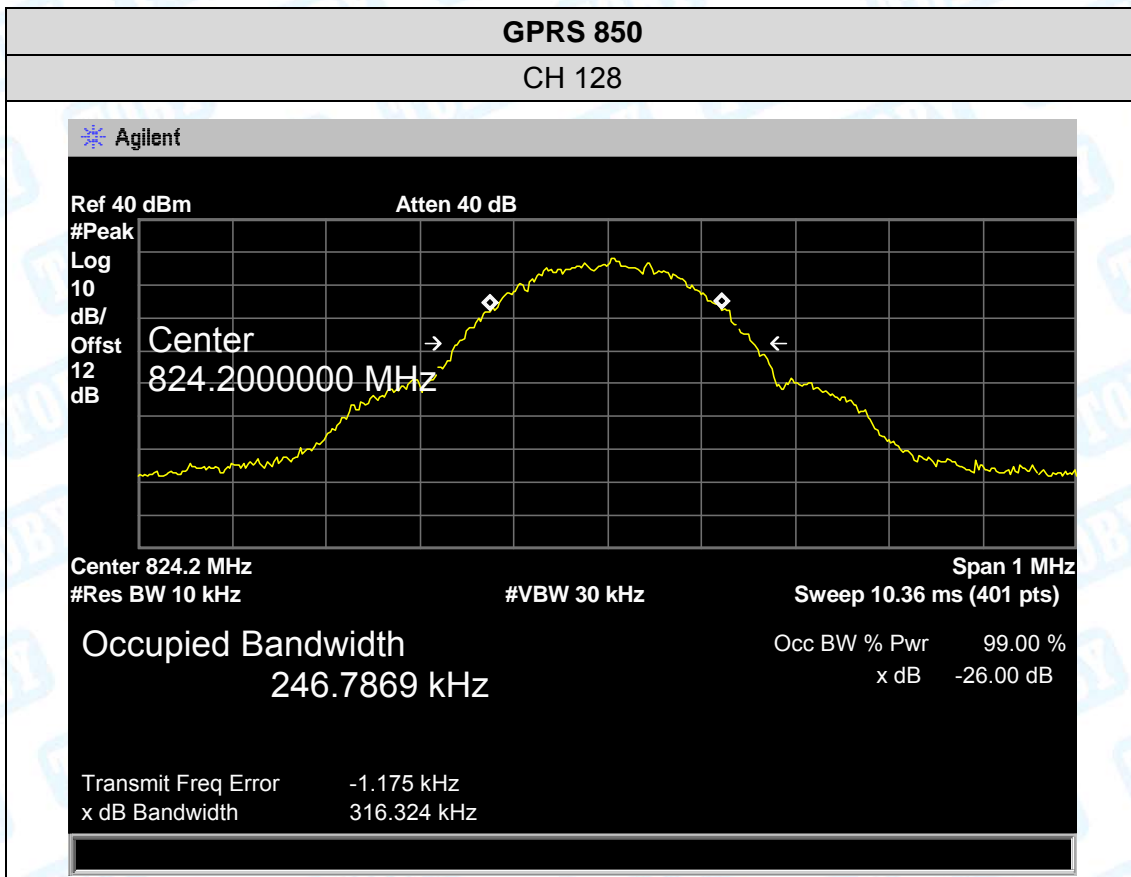

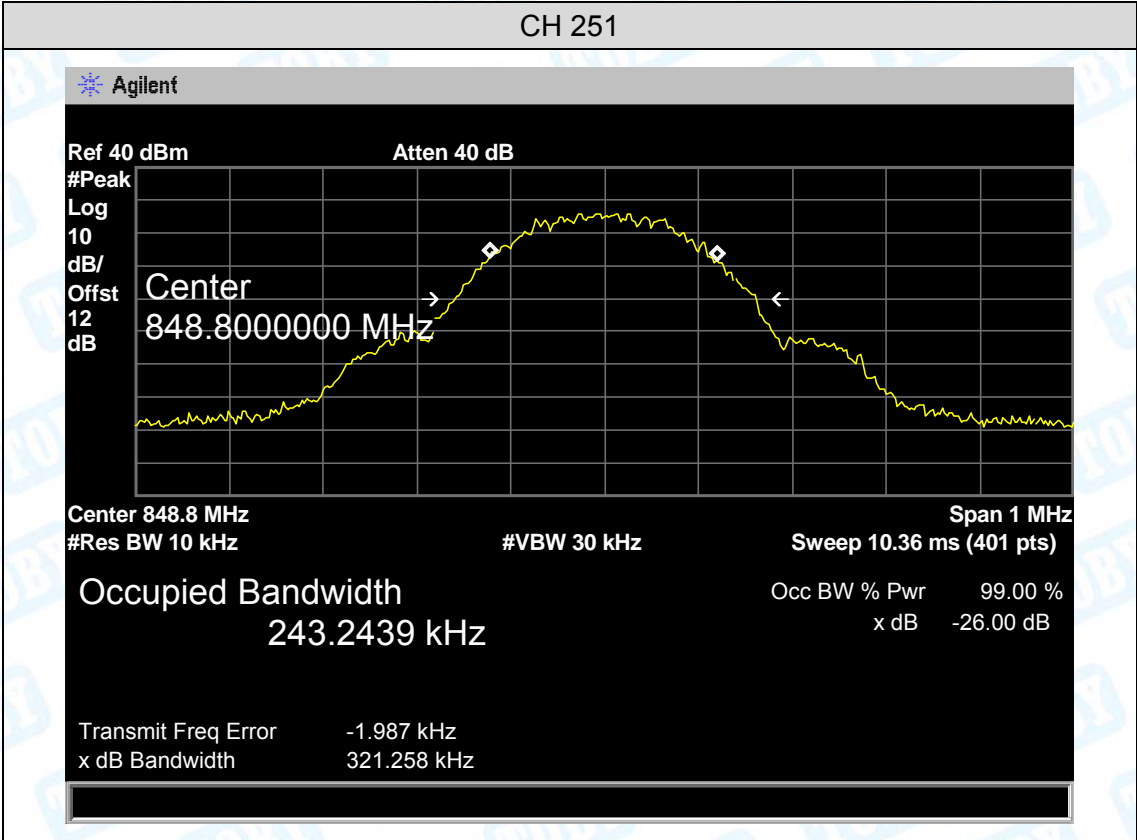

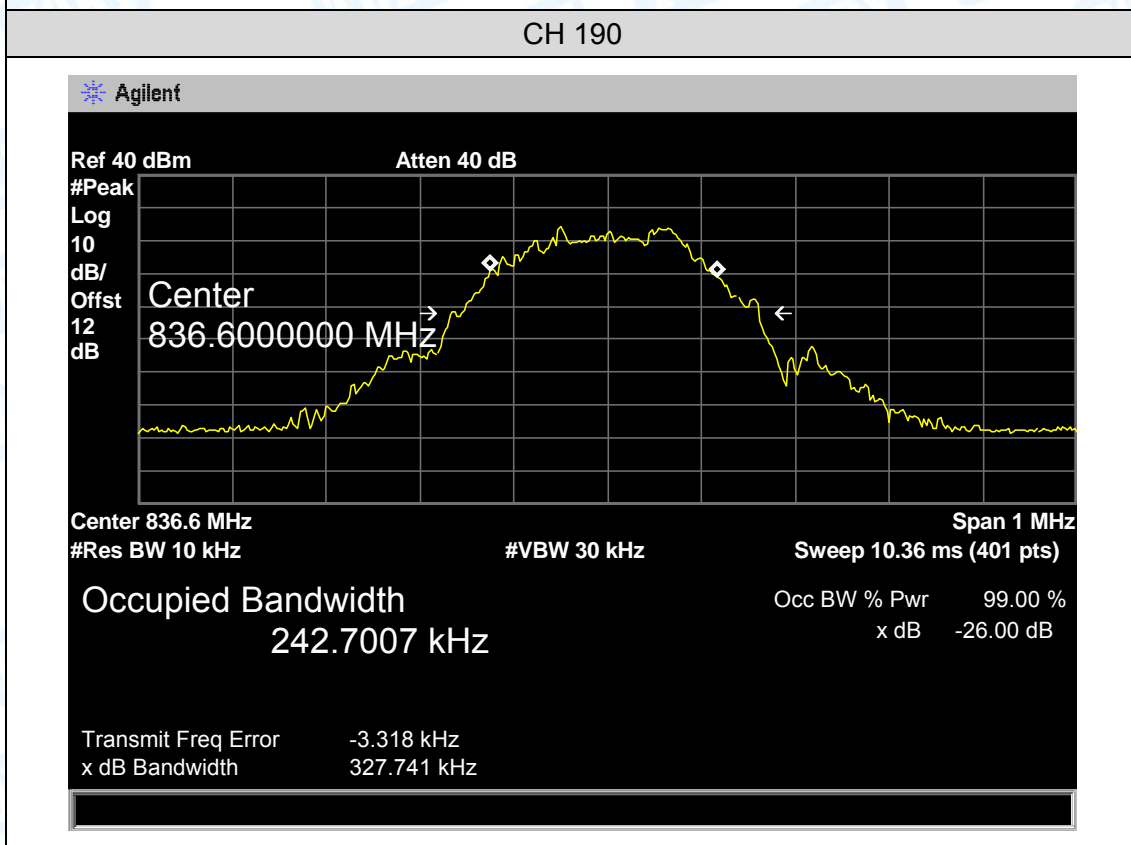
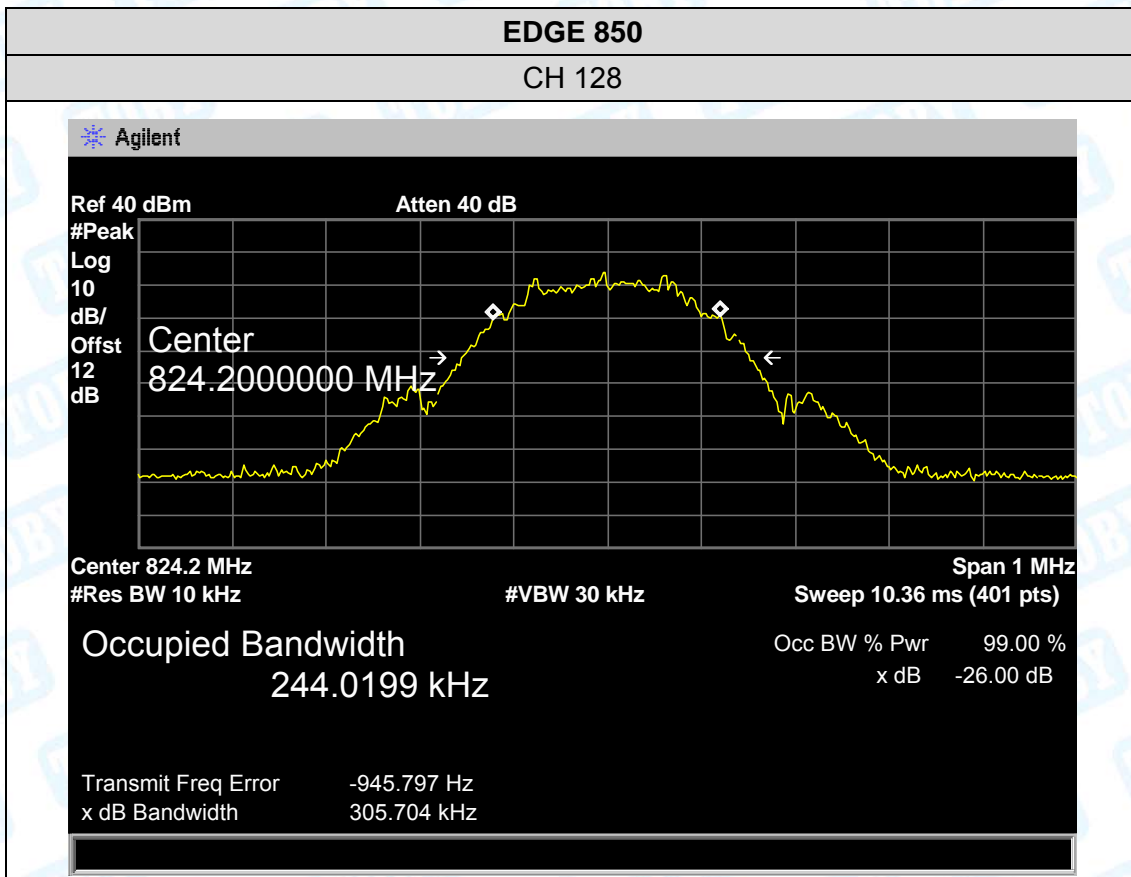

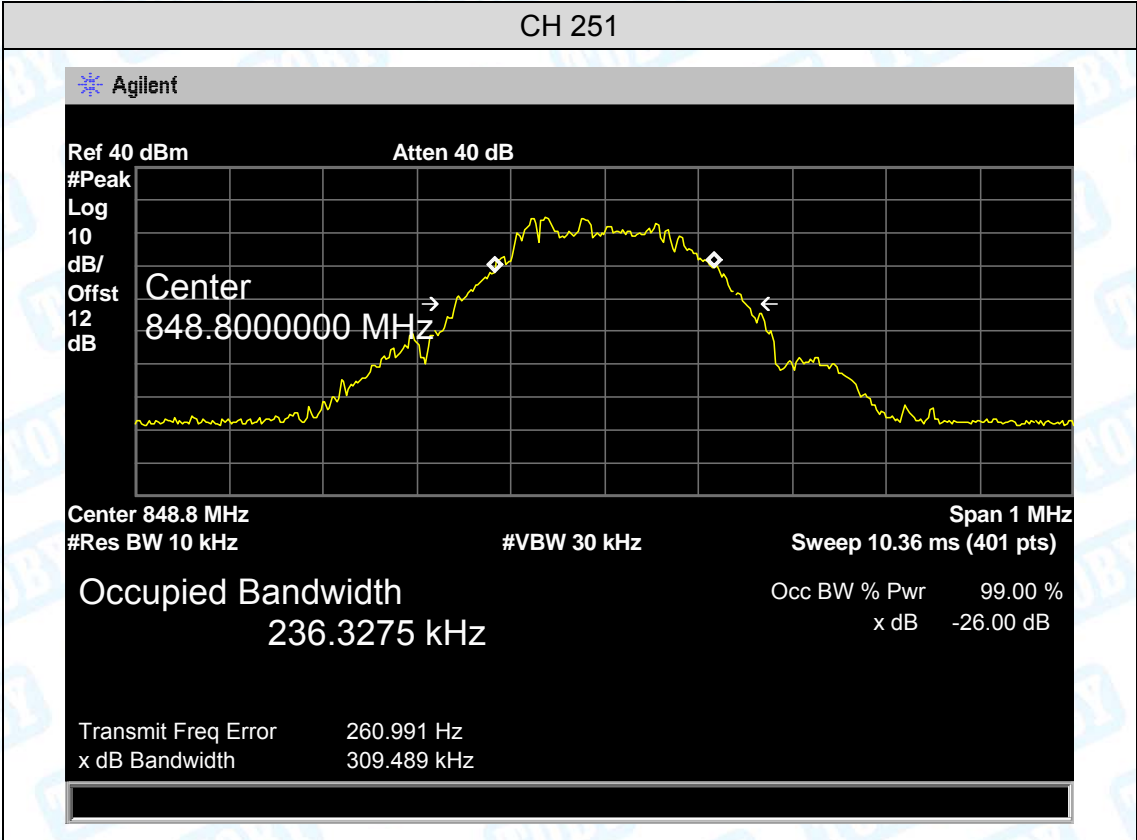

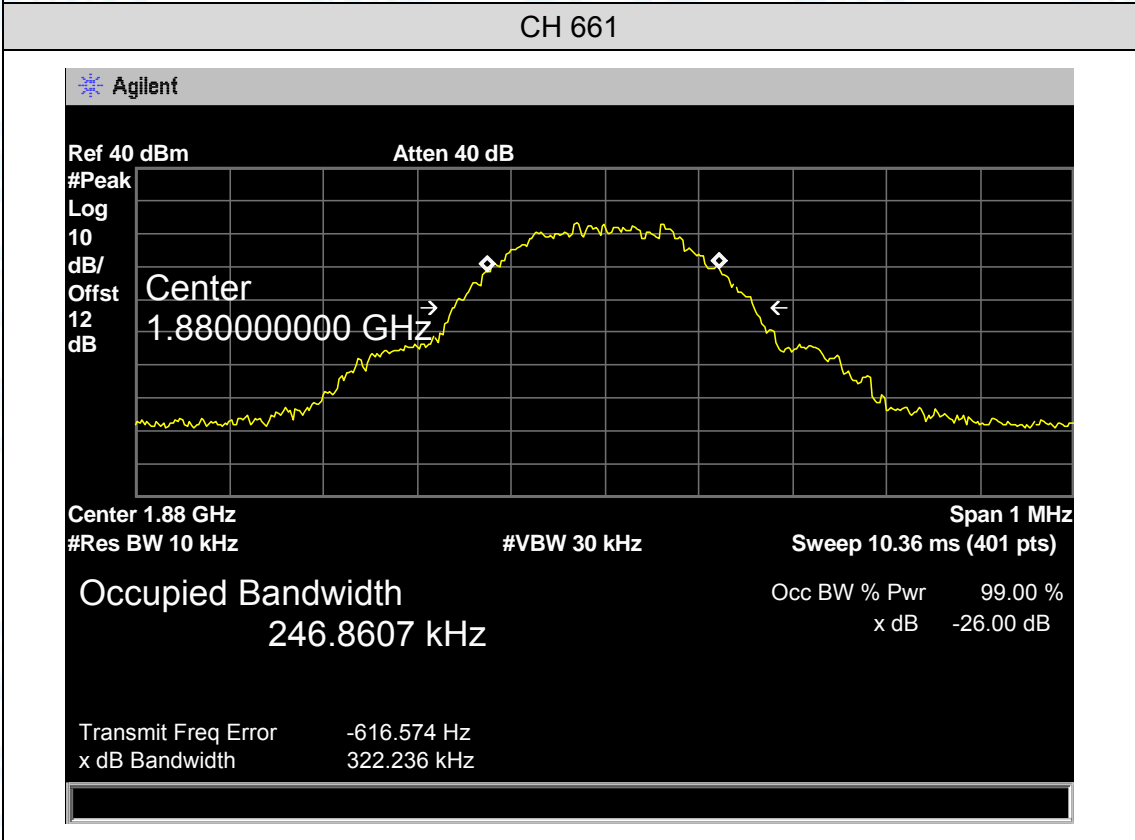
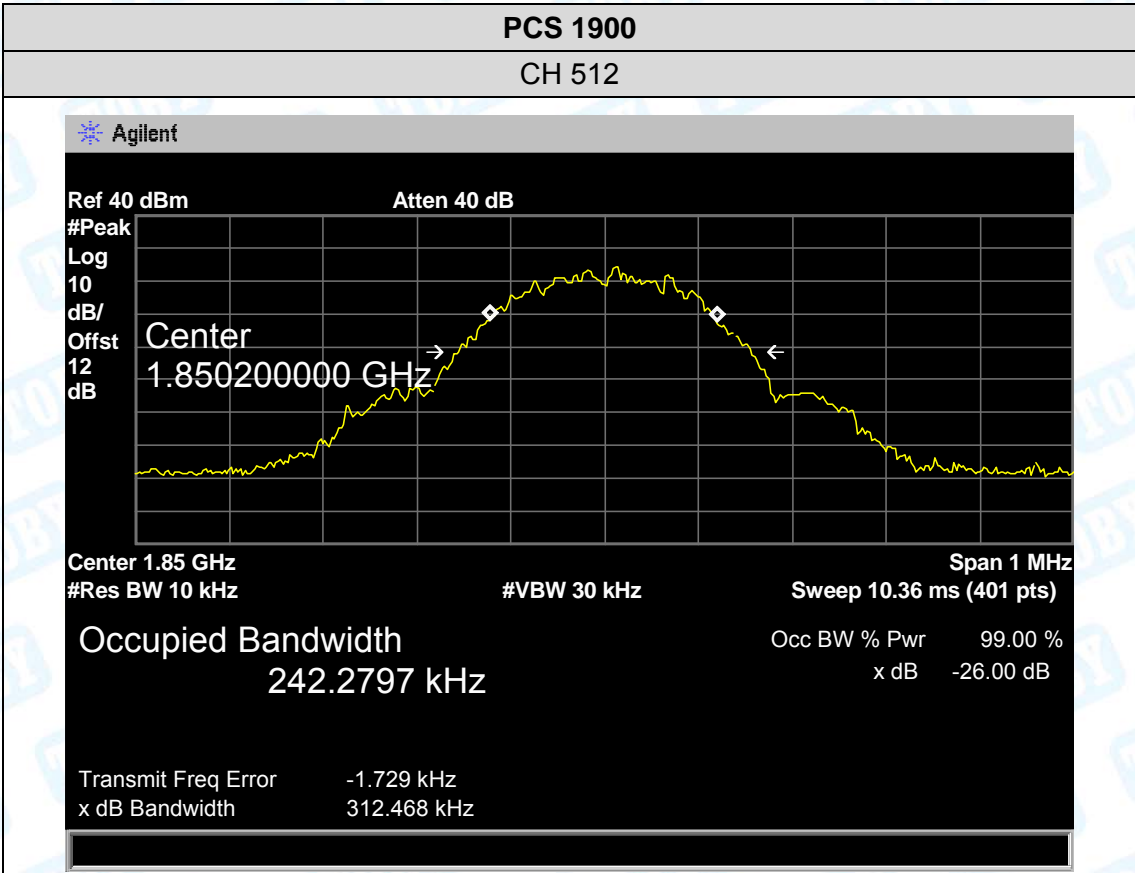

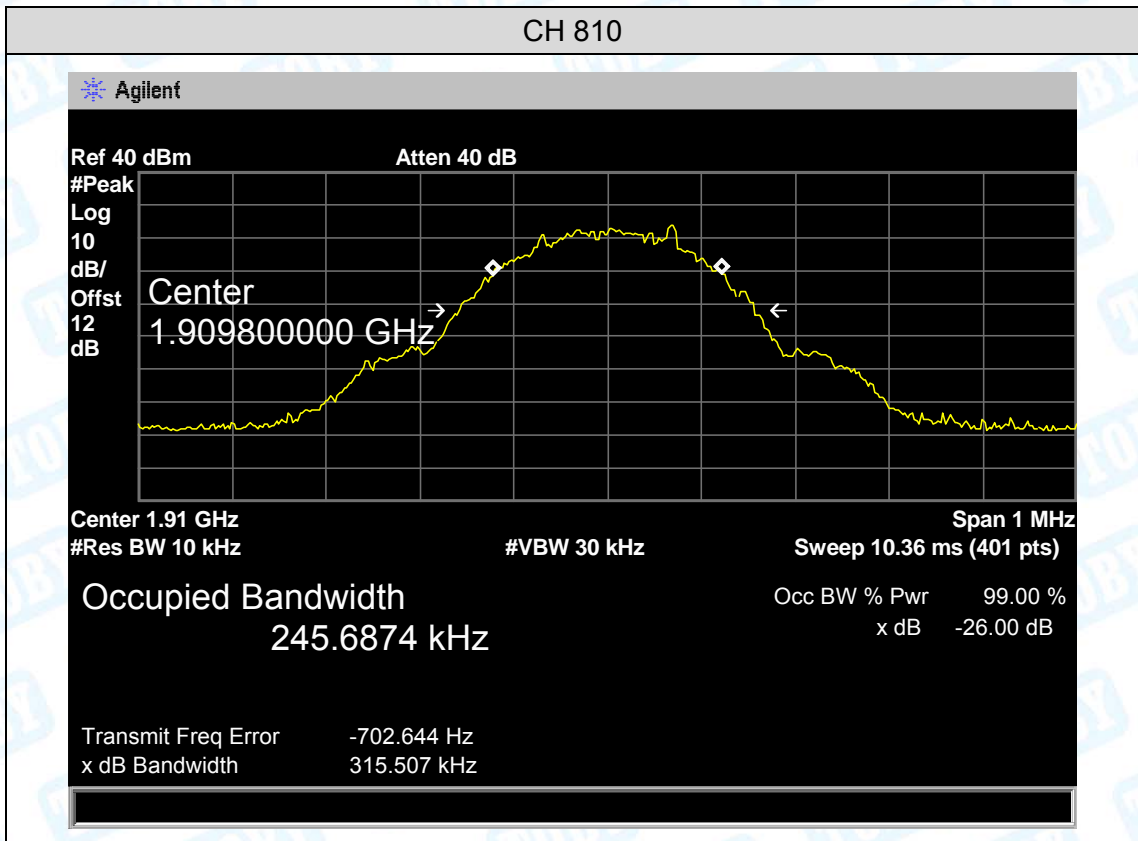

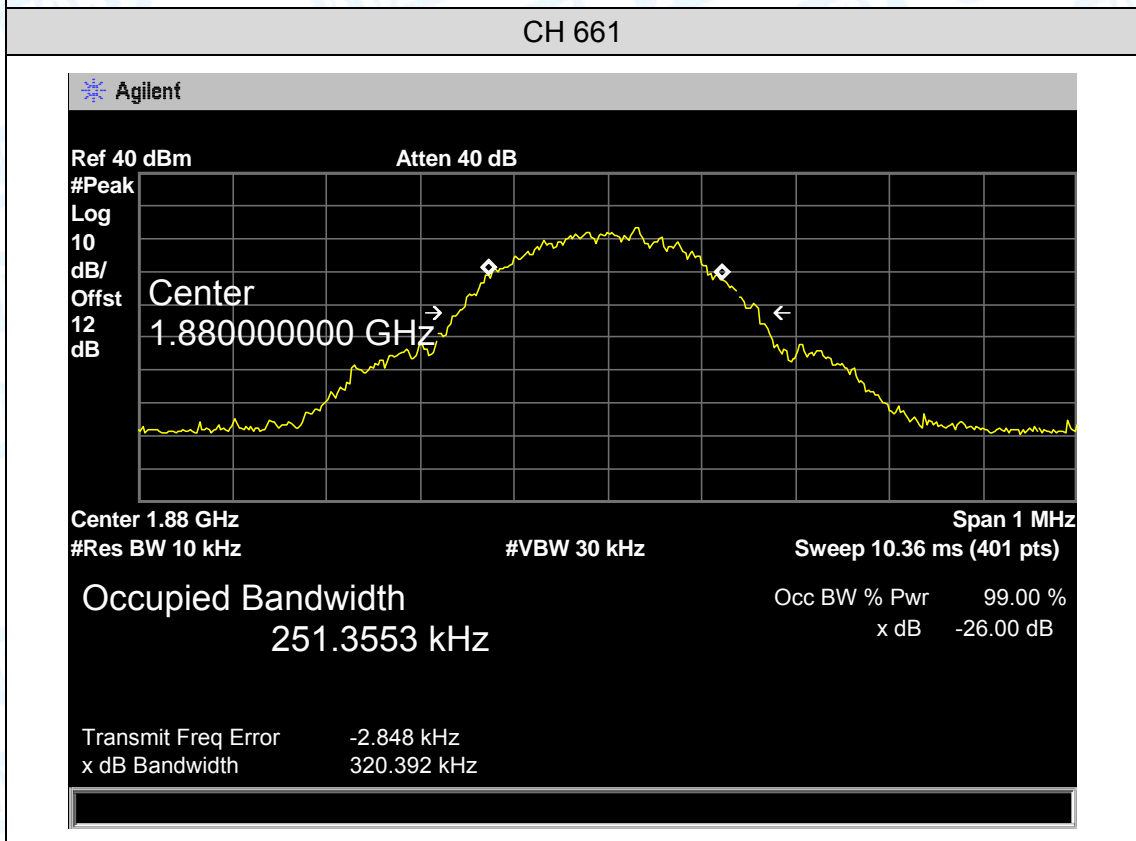
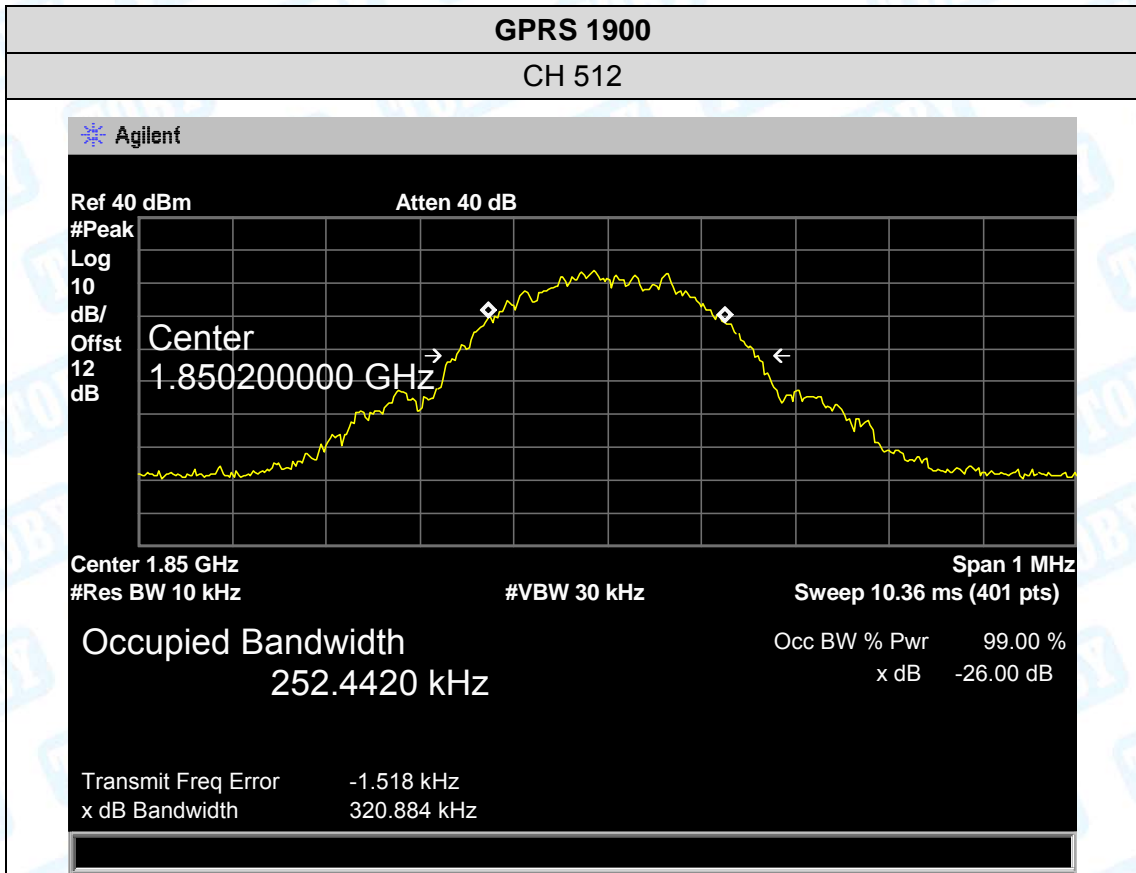

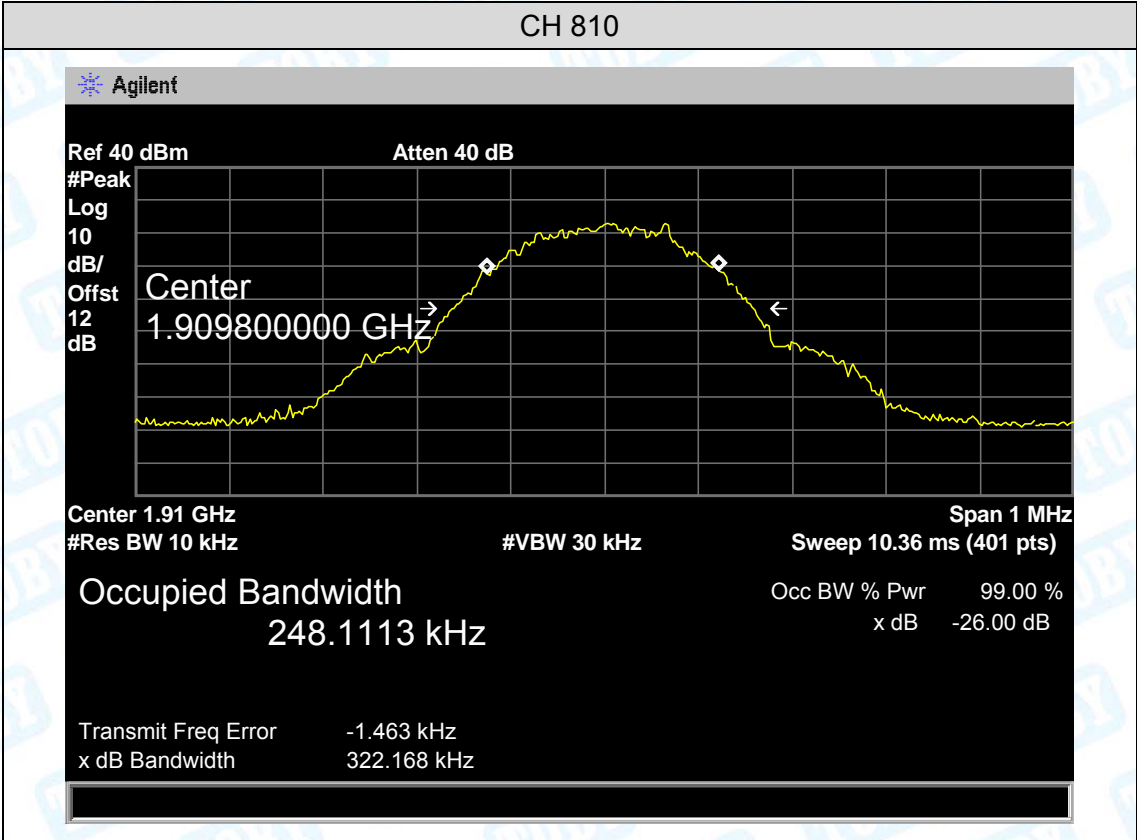

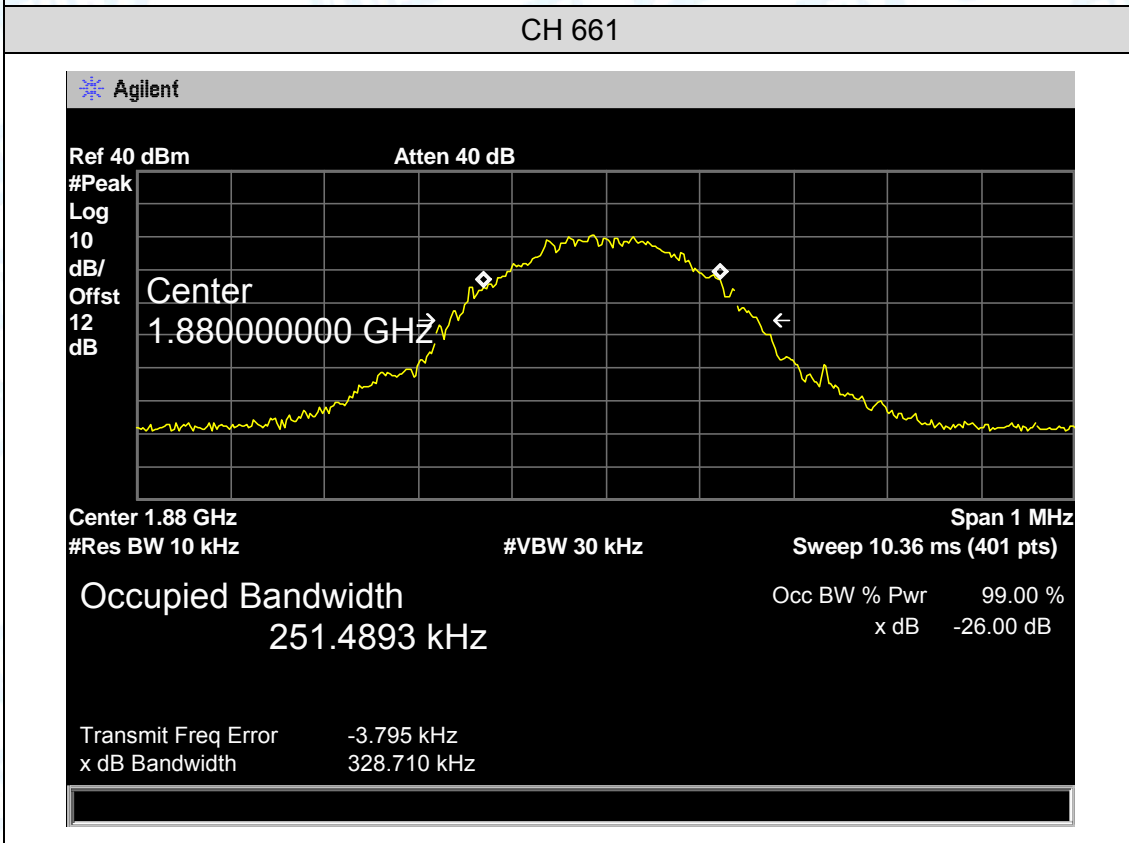
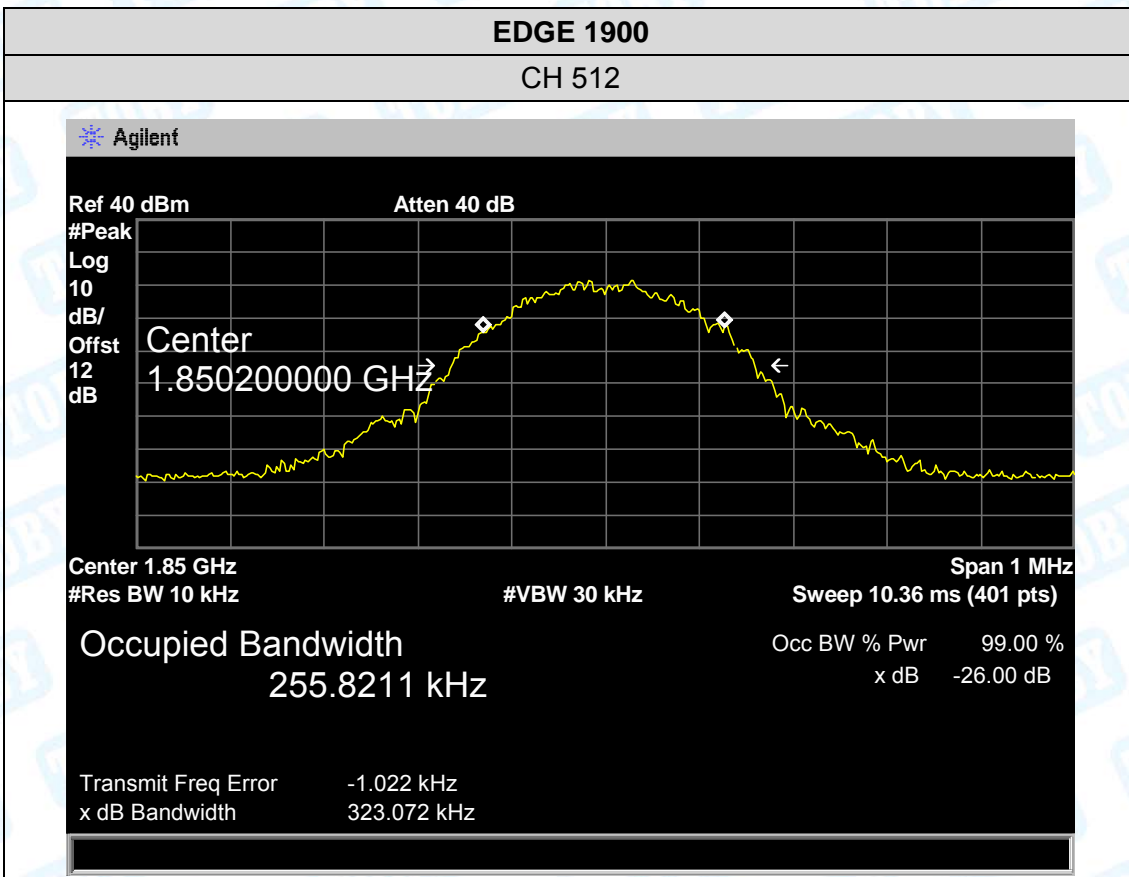

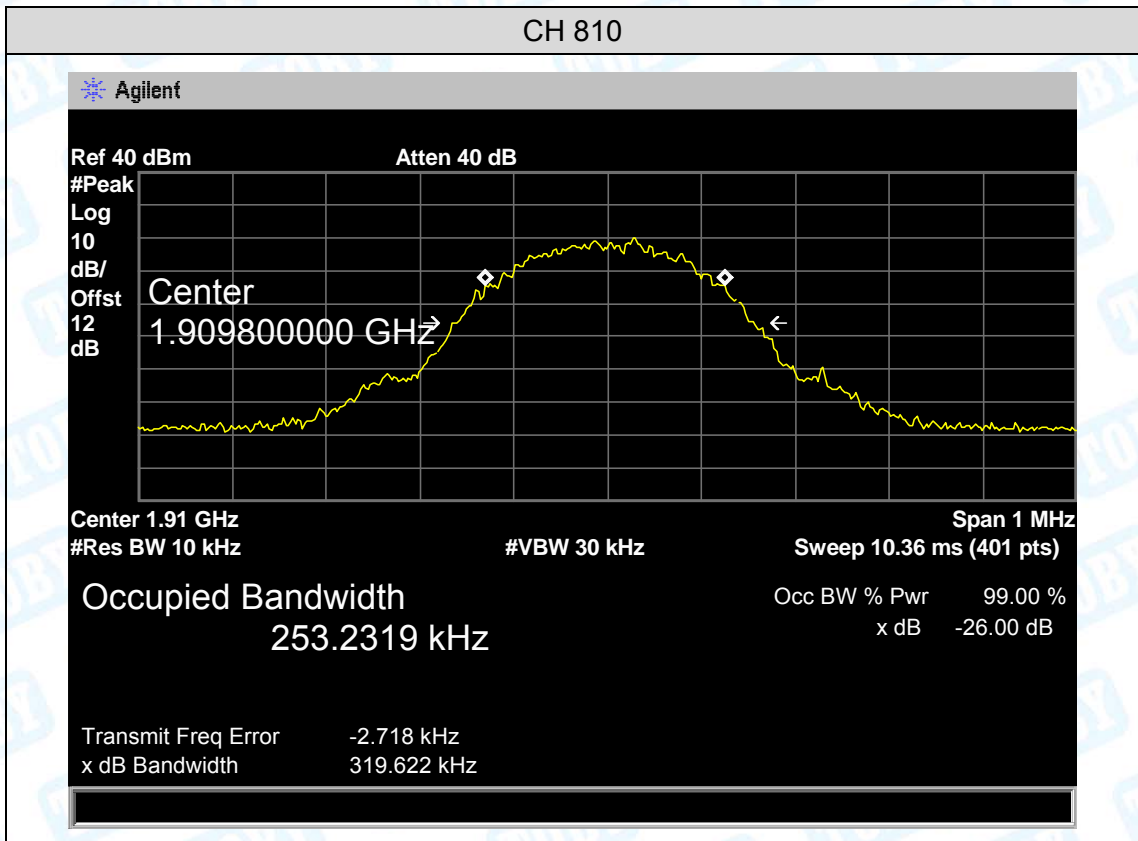

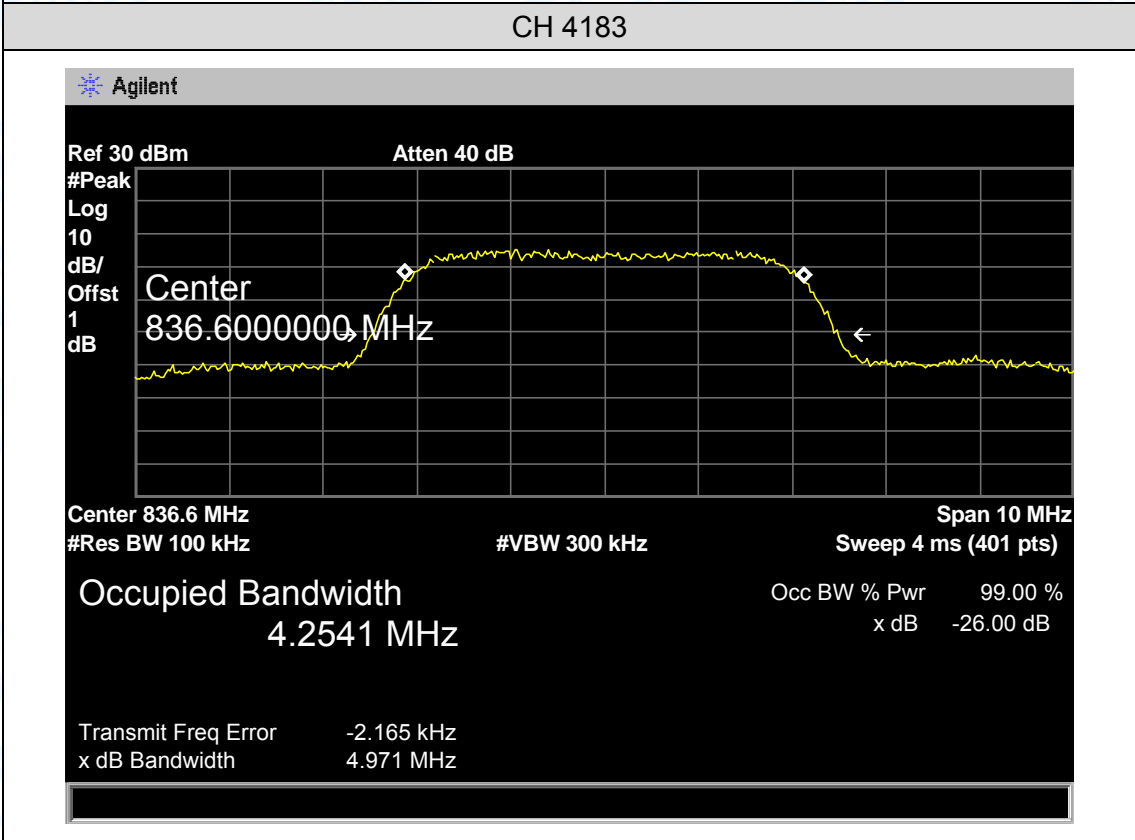
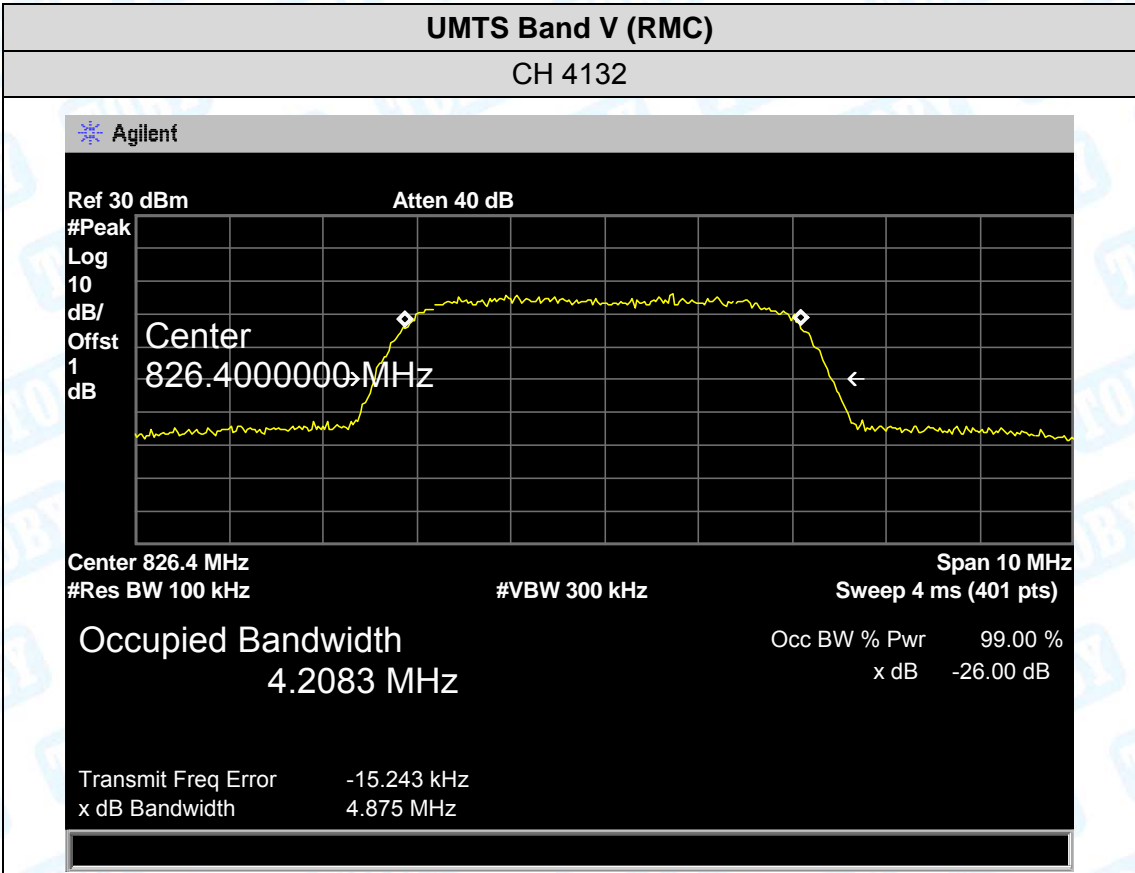

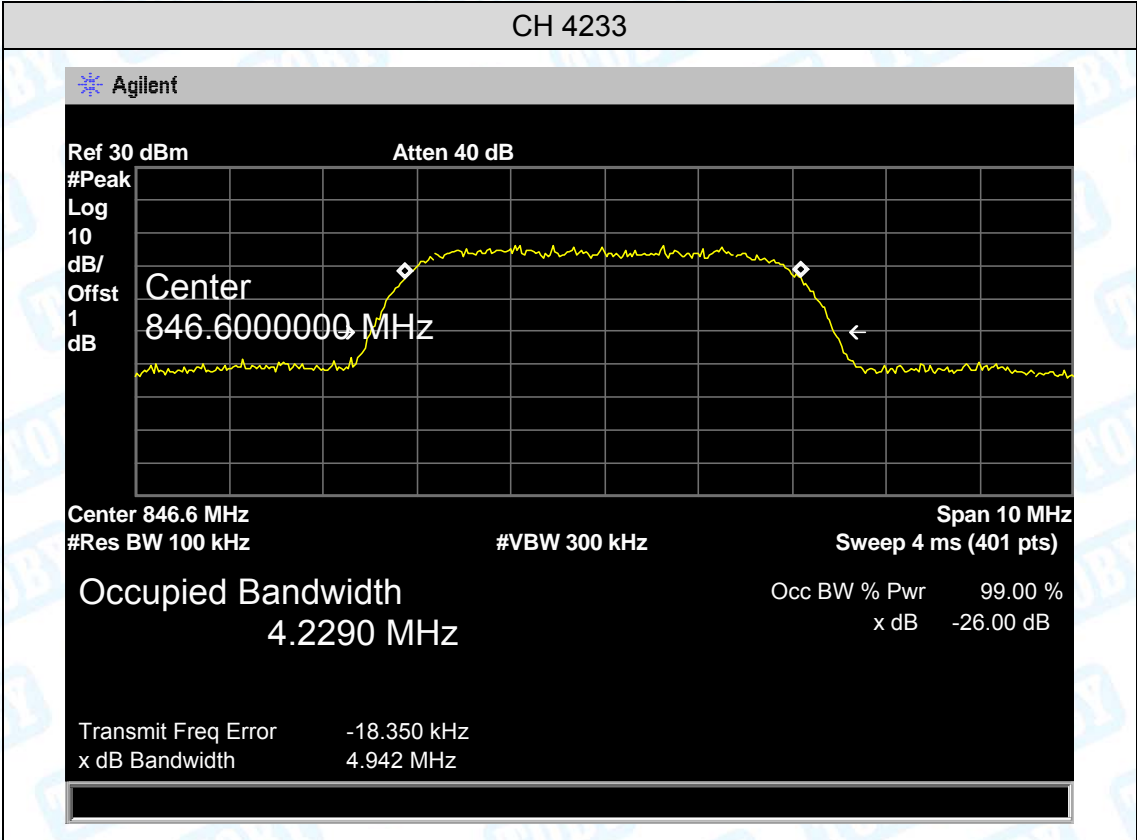

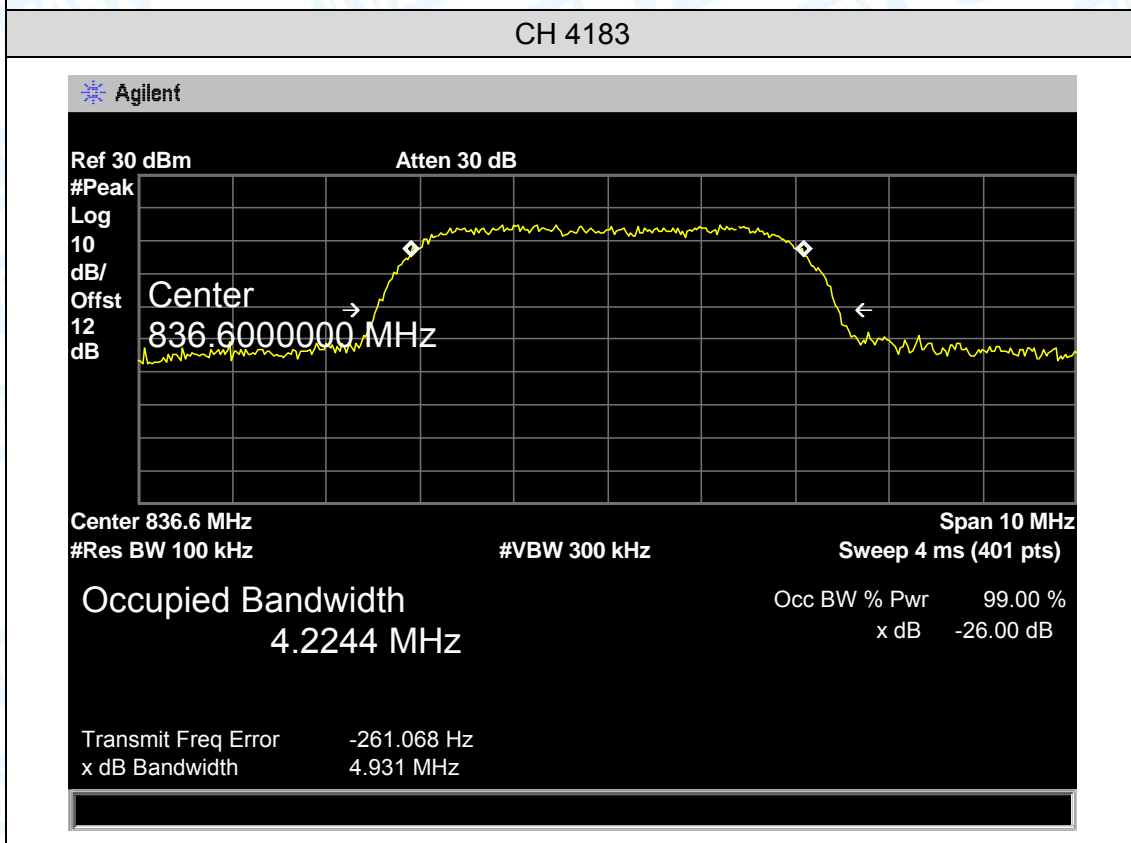
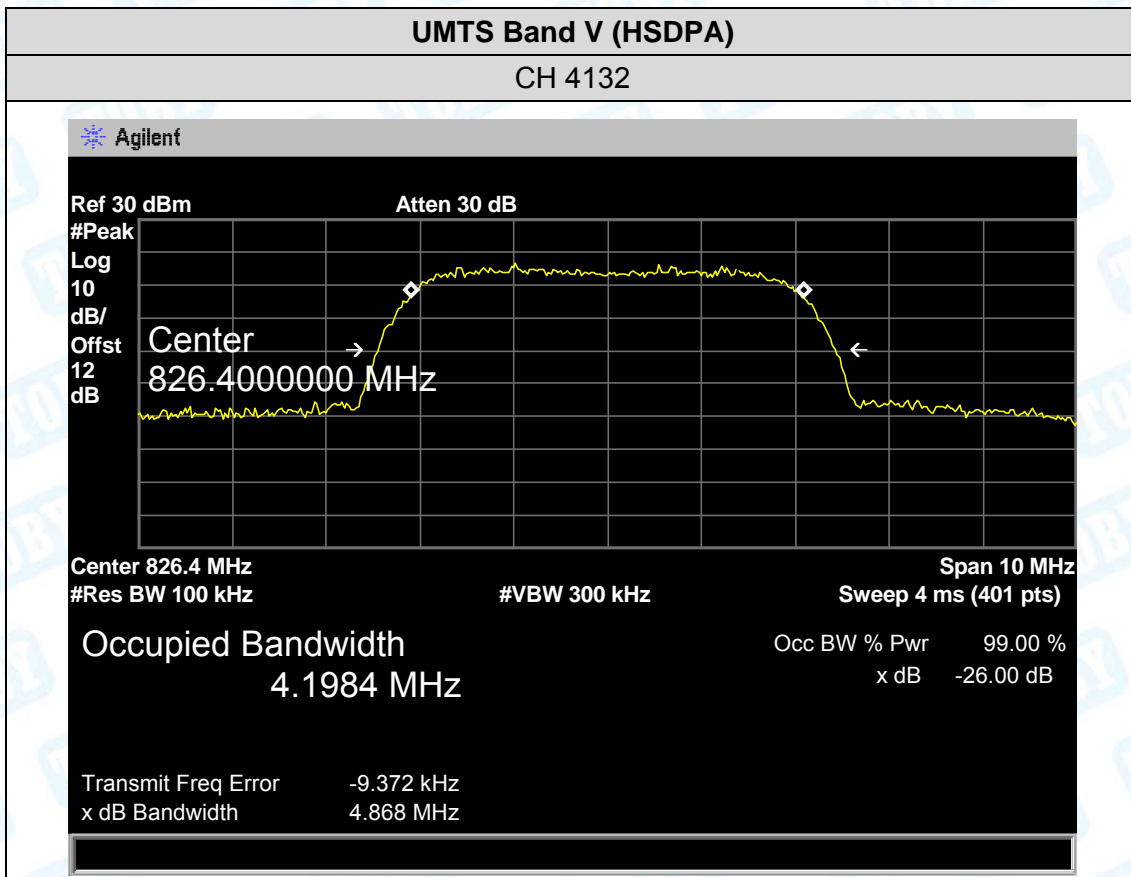

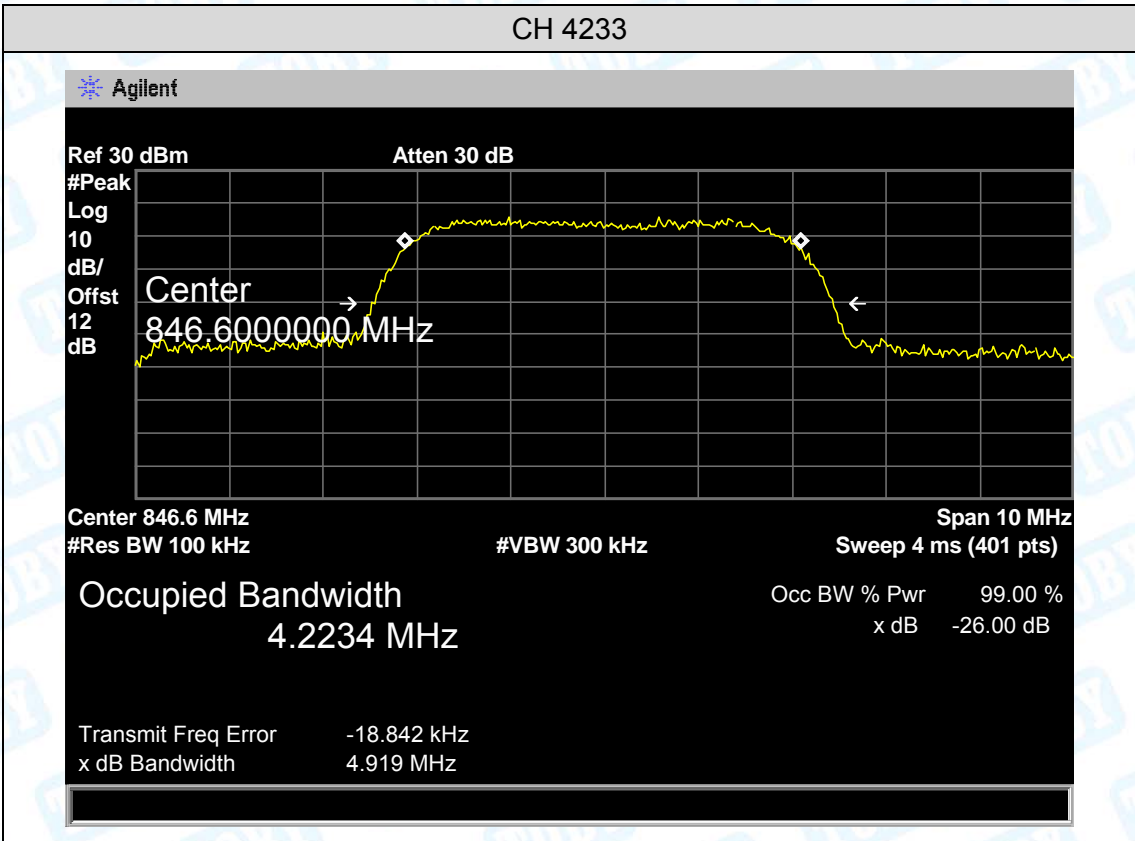

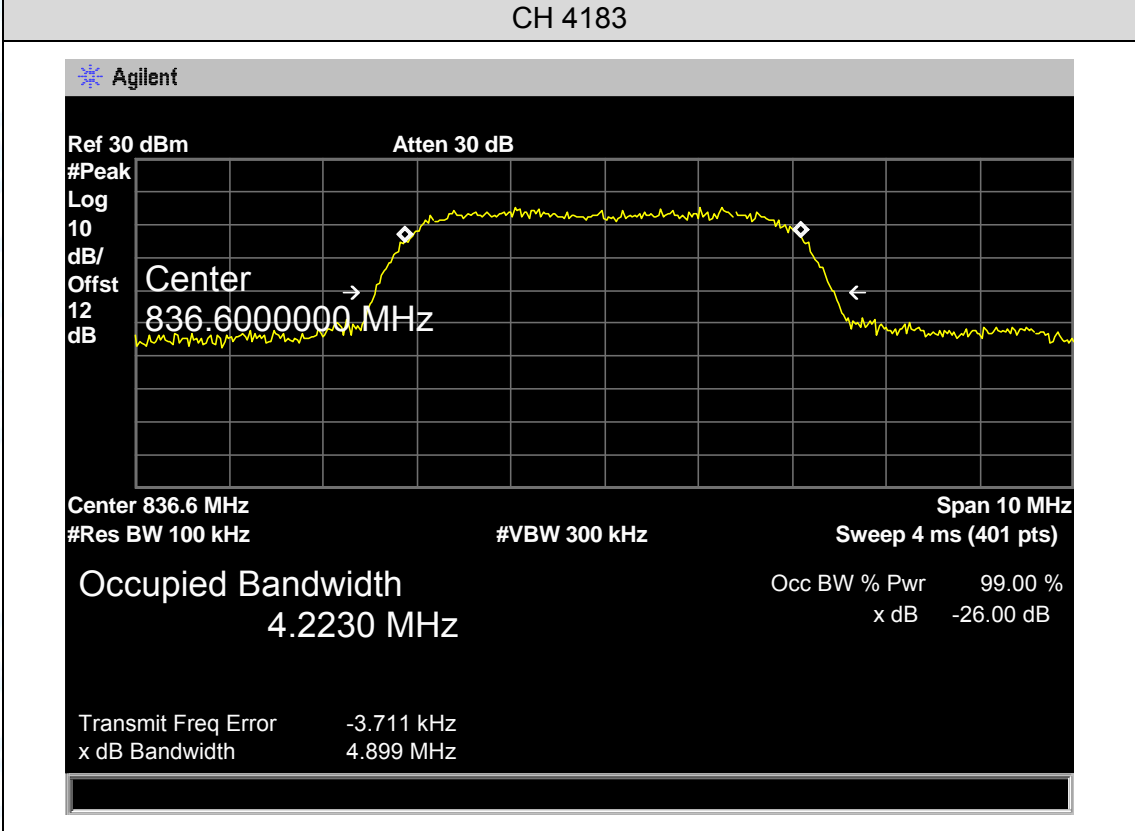
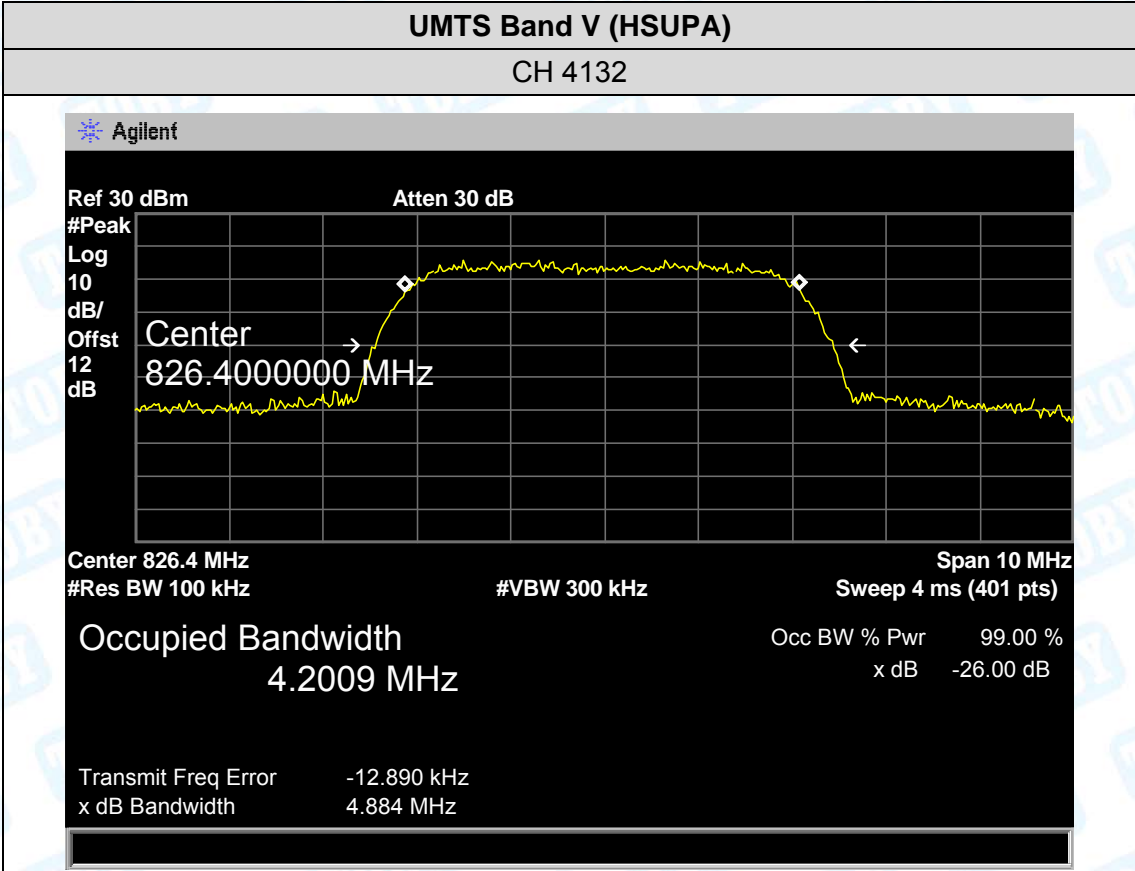

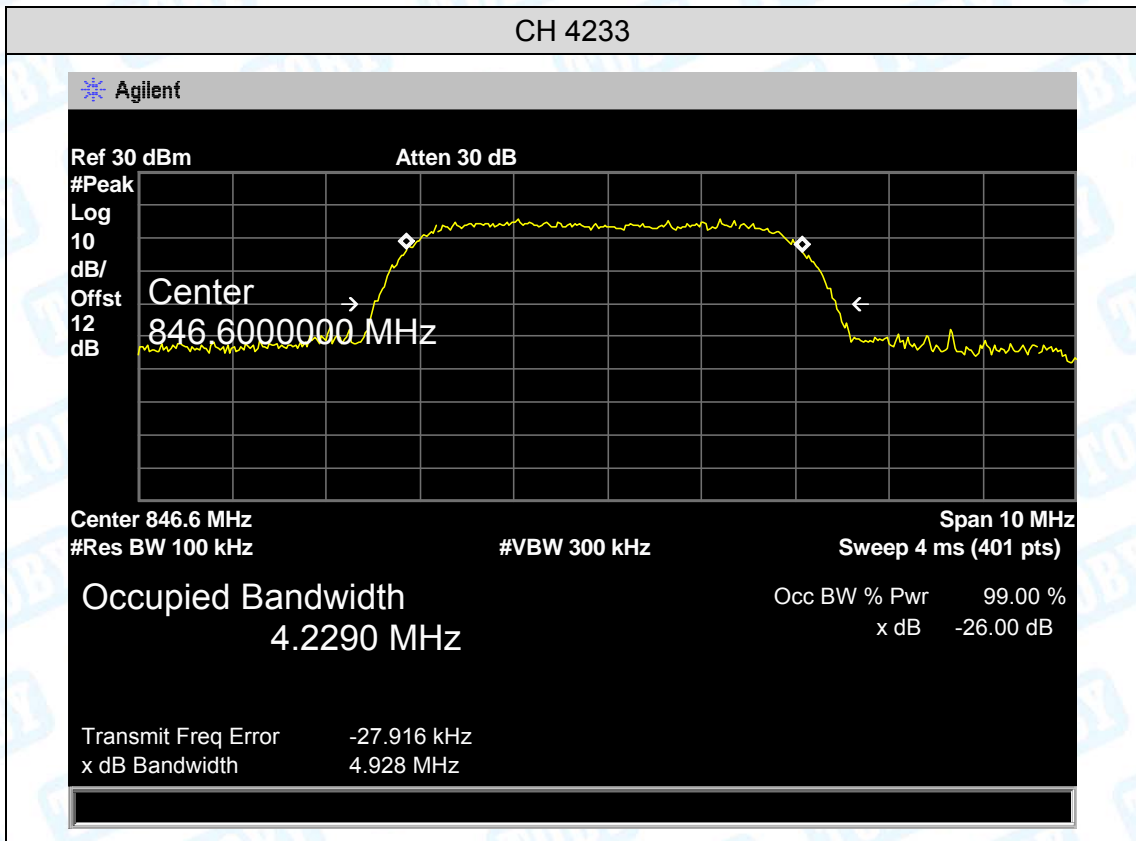

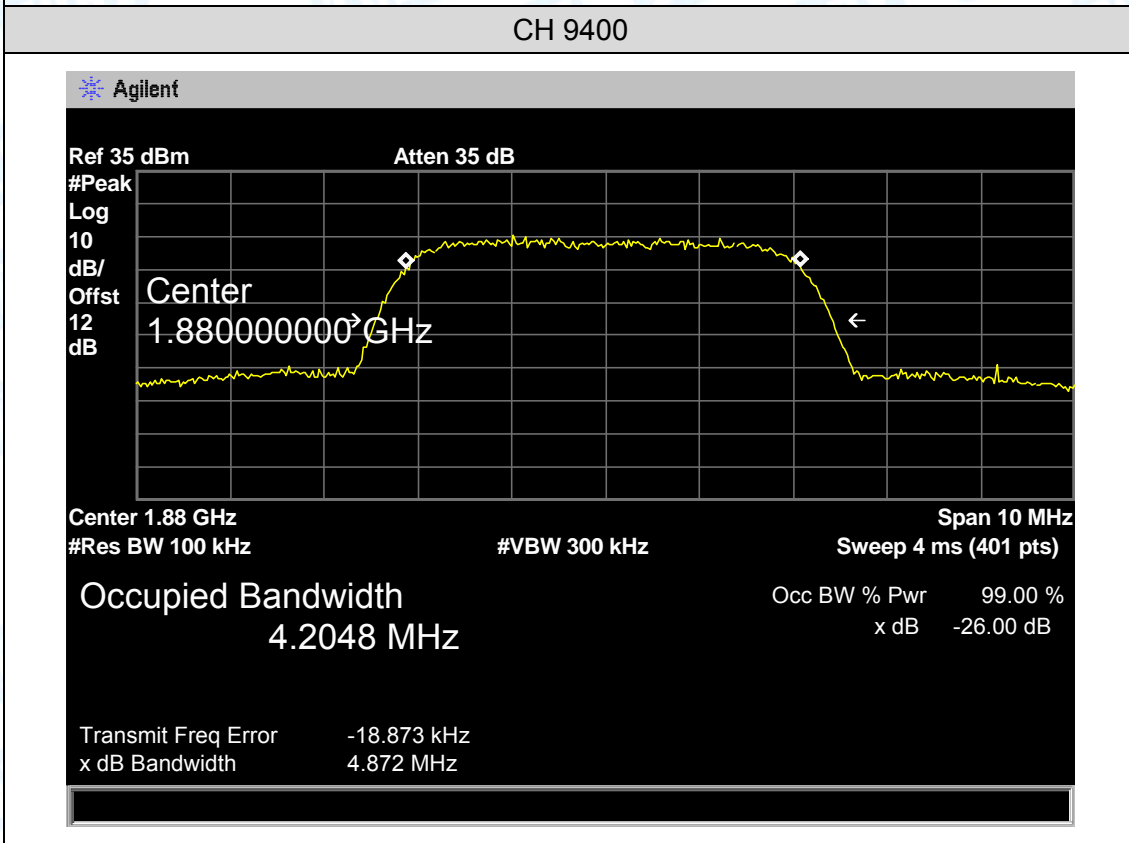
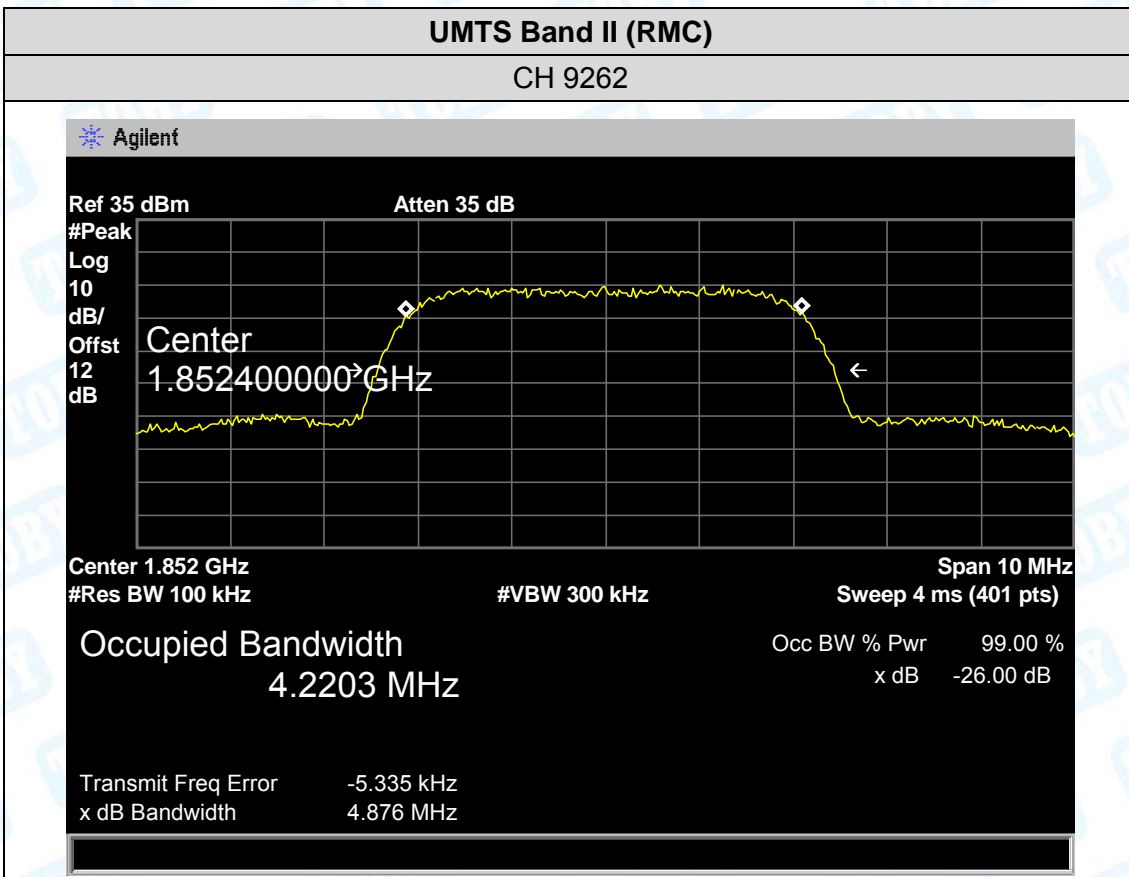

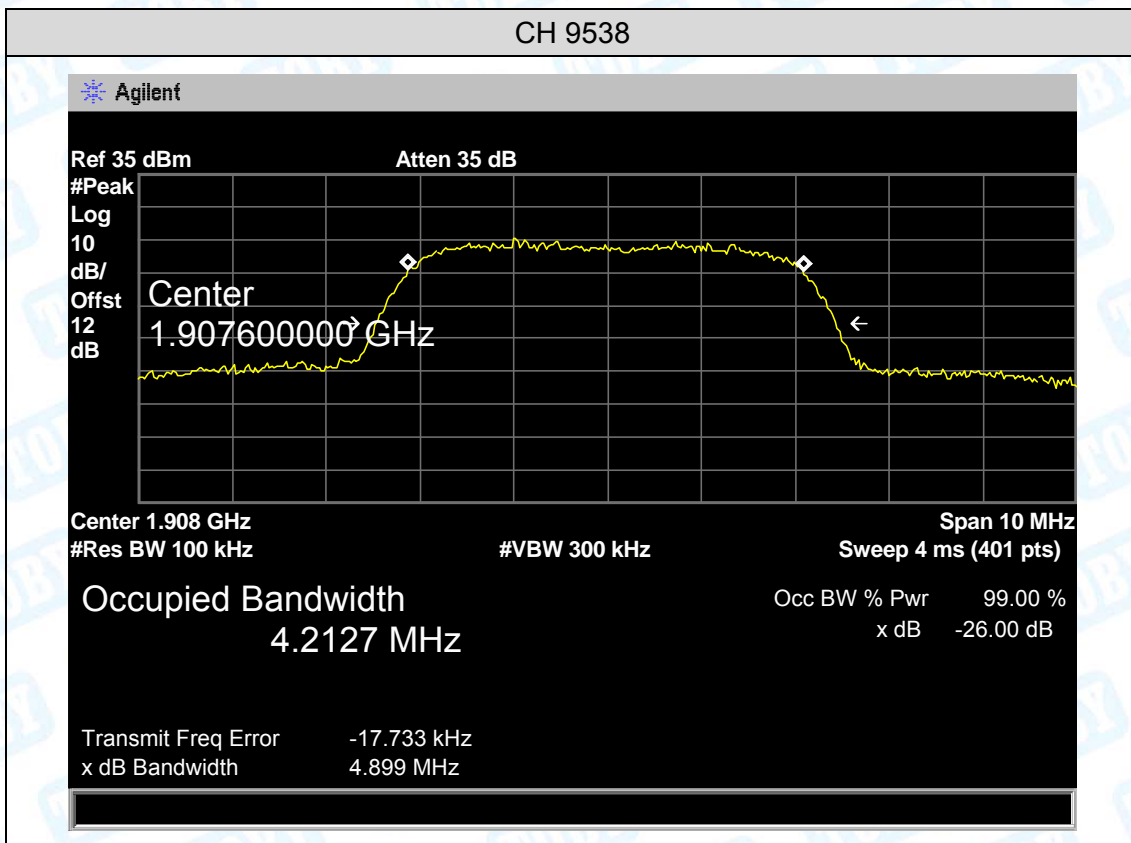

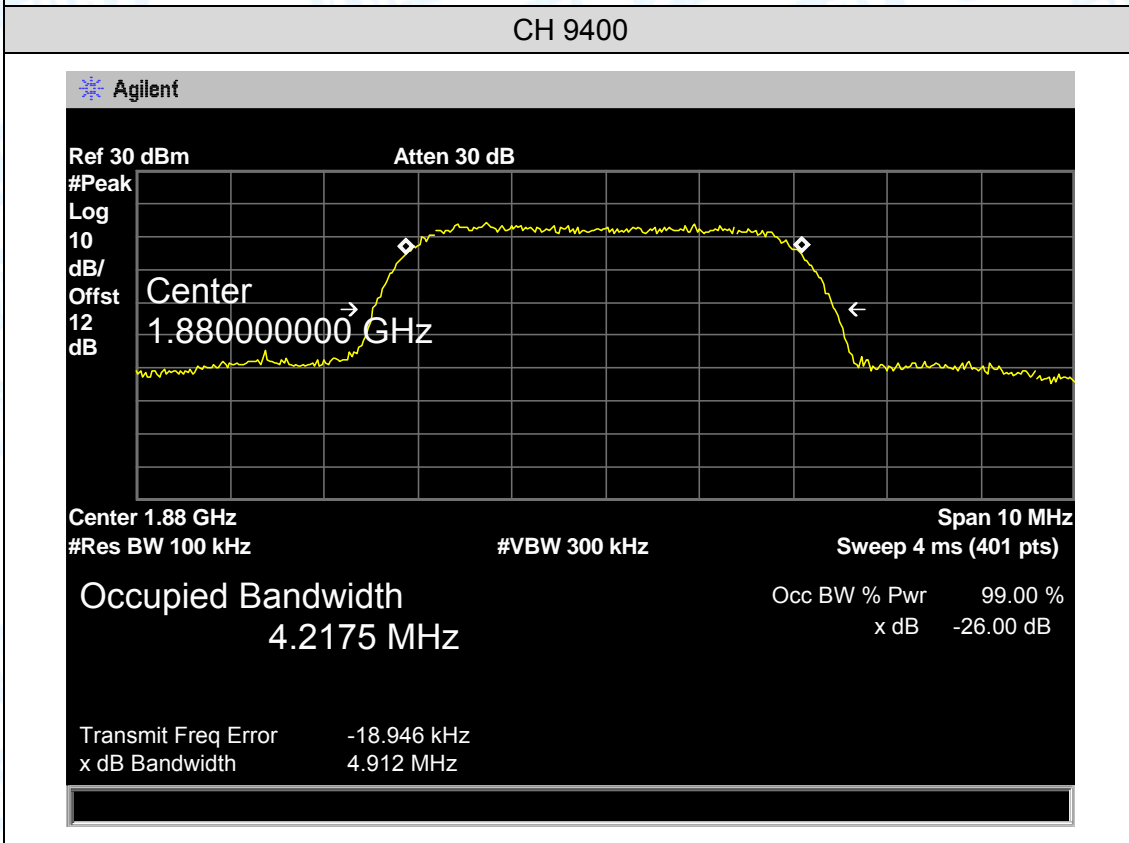
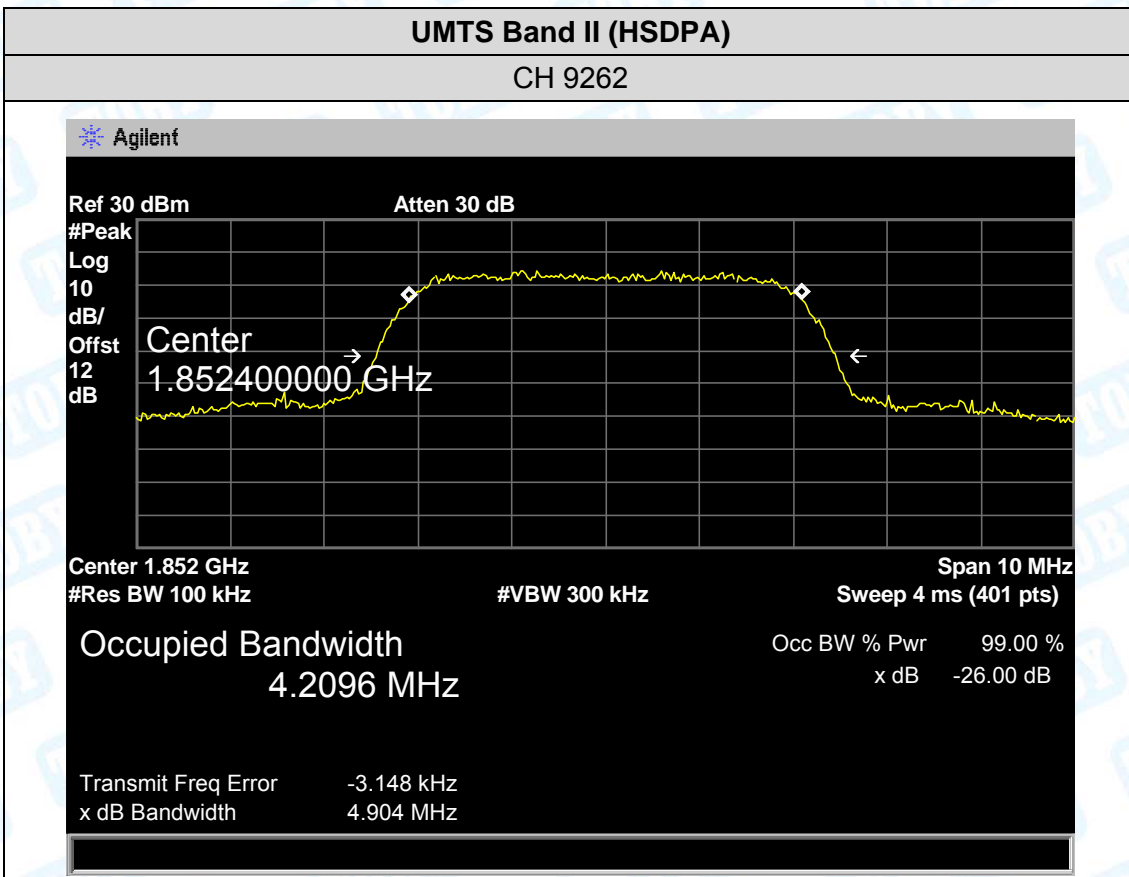

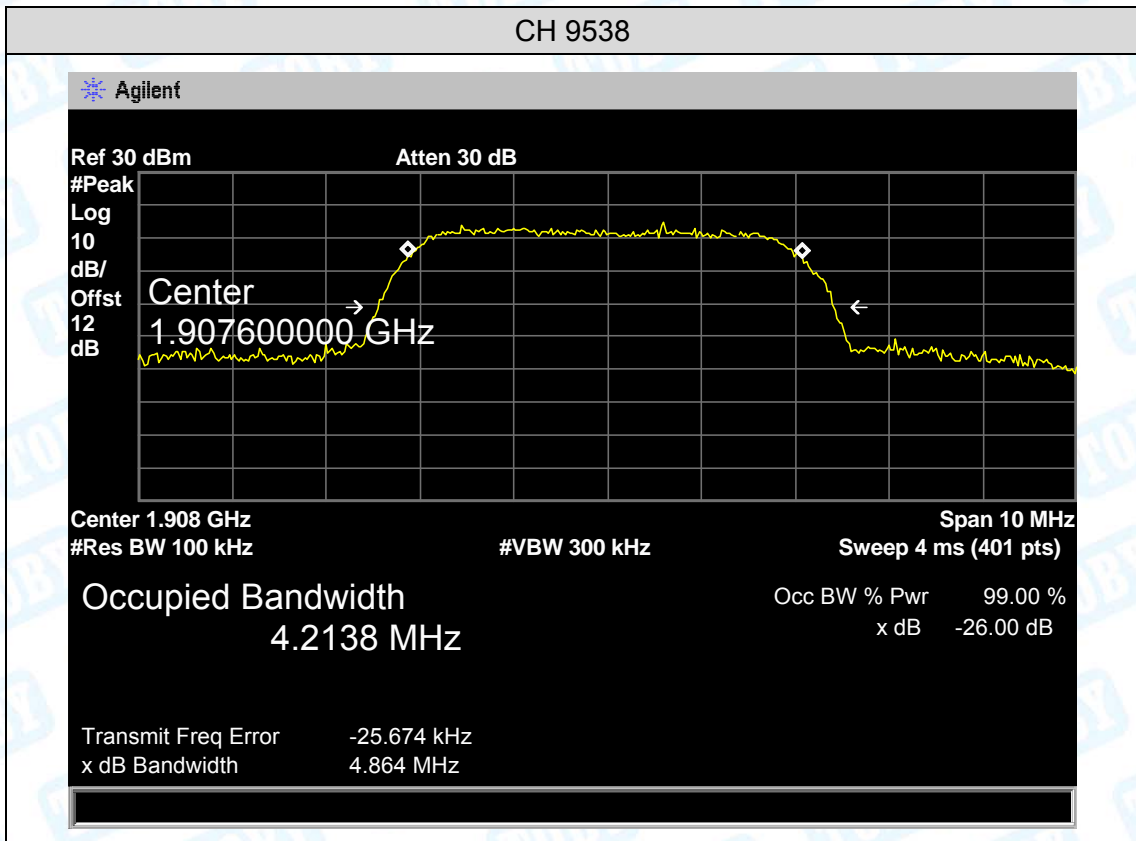

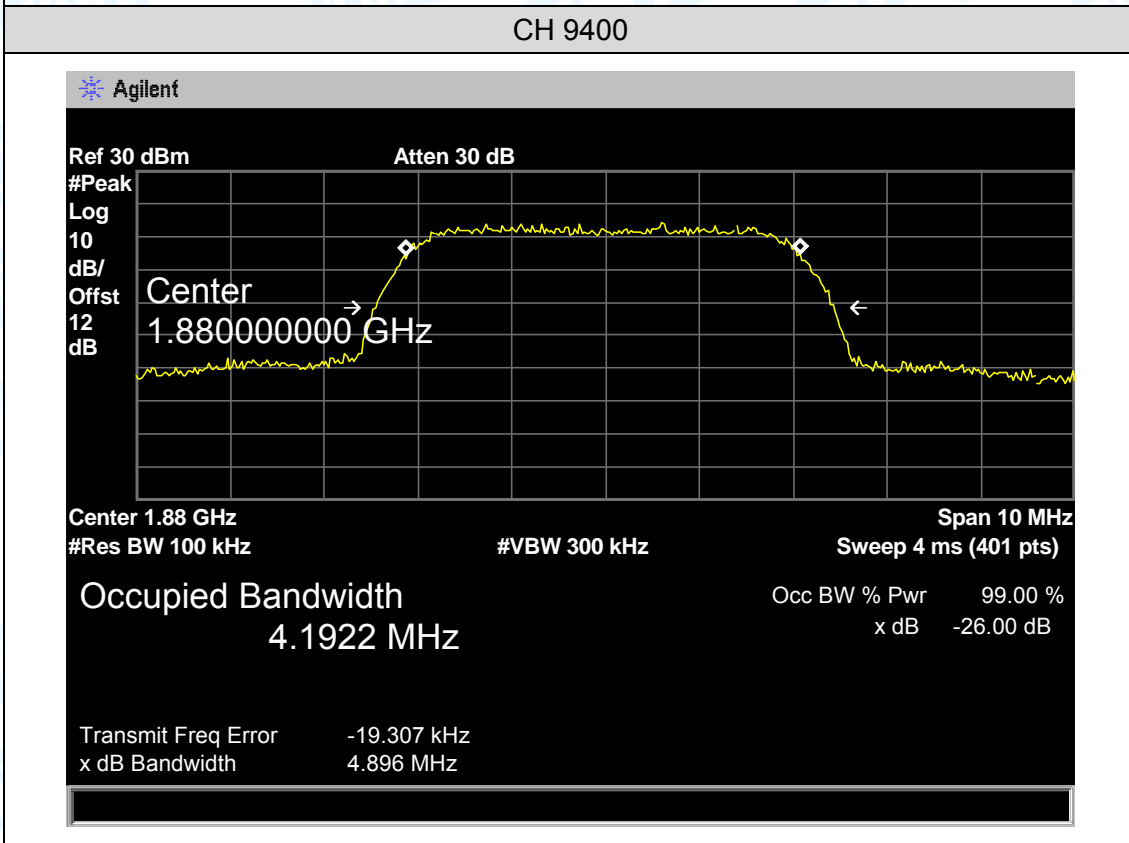
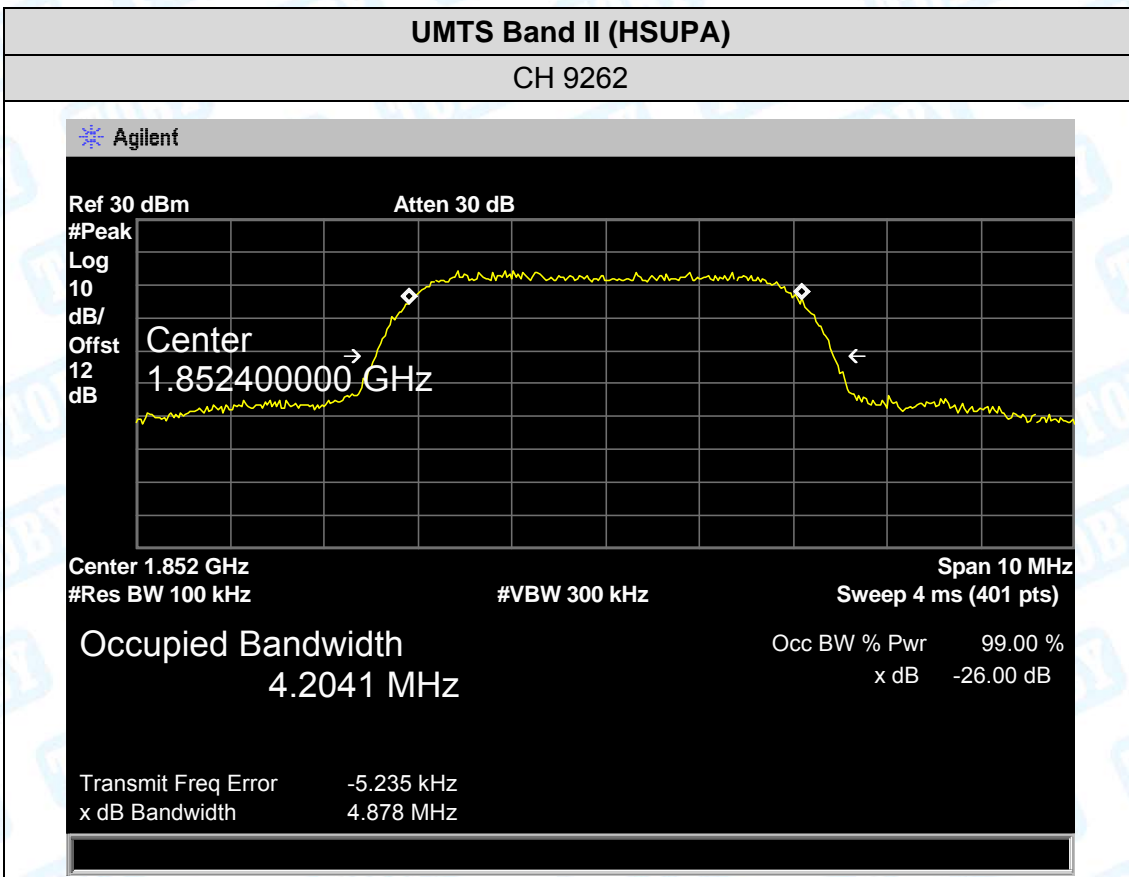

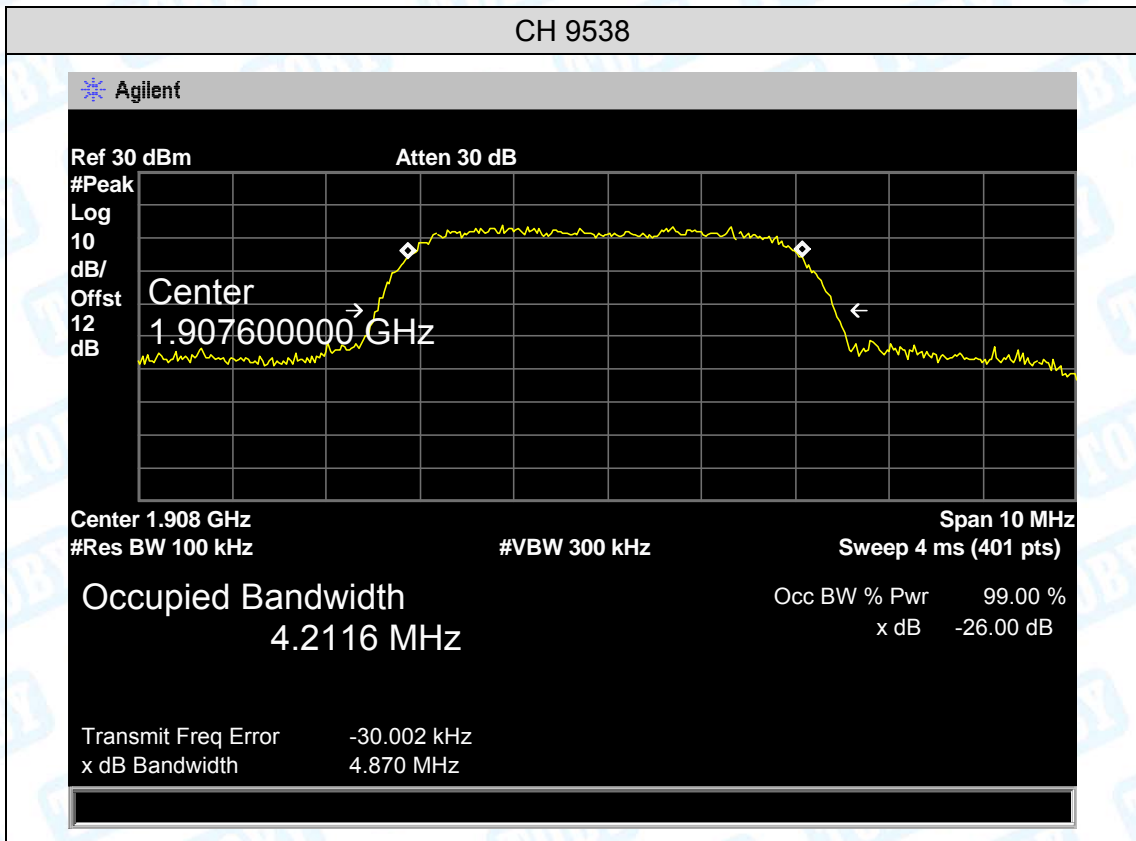

9. Conducted Out of Band Emissions

9.1 Test Standard and Limit

9.1.1 Test Standard

FCC Part 2: 2.1051, 2.1057

FCC Part 22H: 22.917(a)

FCC Part 24E: 24.238(a)

9.1.2 Test Limit

The power of any emission outside of the authorized operating frequency ranges must be attenuated below the transmitting power(P) by a factor of at least $43+10\log(P)$ dB. For all power levels +30 dBm to 0 dBm, this becomes a constant specification limit of -13 dBm.

9.2 Test Setup

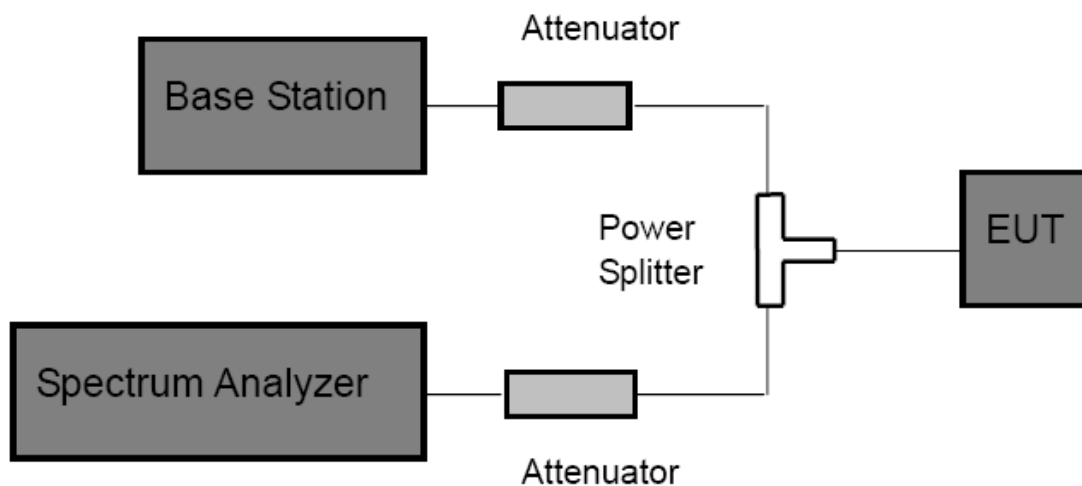

9.3 Test Procedure

- (1) The EUT was directly connected to the spectrum analyzer and Base station via power splitter as show in the block diagram above.
- (2) Spectrum Setting:
 Frequency bellow 1 GHz: RBW=100 kHz, VBW=300 kHz.
 Frequency above 1 GHz: RBW=1 MHz, VBW=3 MHz.
- (3) The low, middle and high channels of each band and mode's spurious emissions for 30 MHz to 10th Harmonic were measured by Spectrum analyzer.

9.4 EUT Operating Condition

The EUT was continuously connected with the Base station and transmitting in the max power during the test.

9.5 Test Data

Please refer following plots:

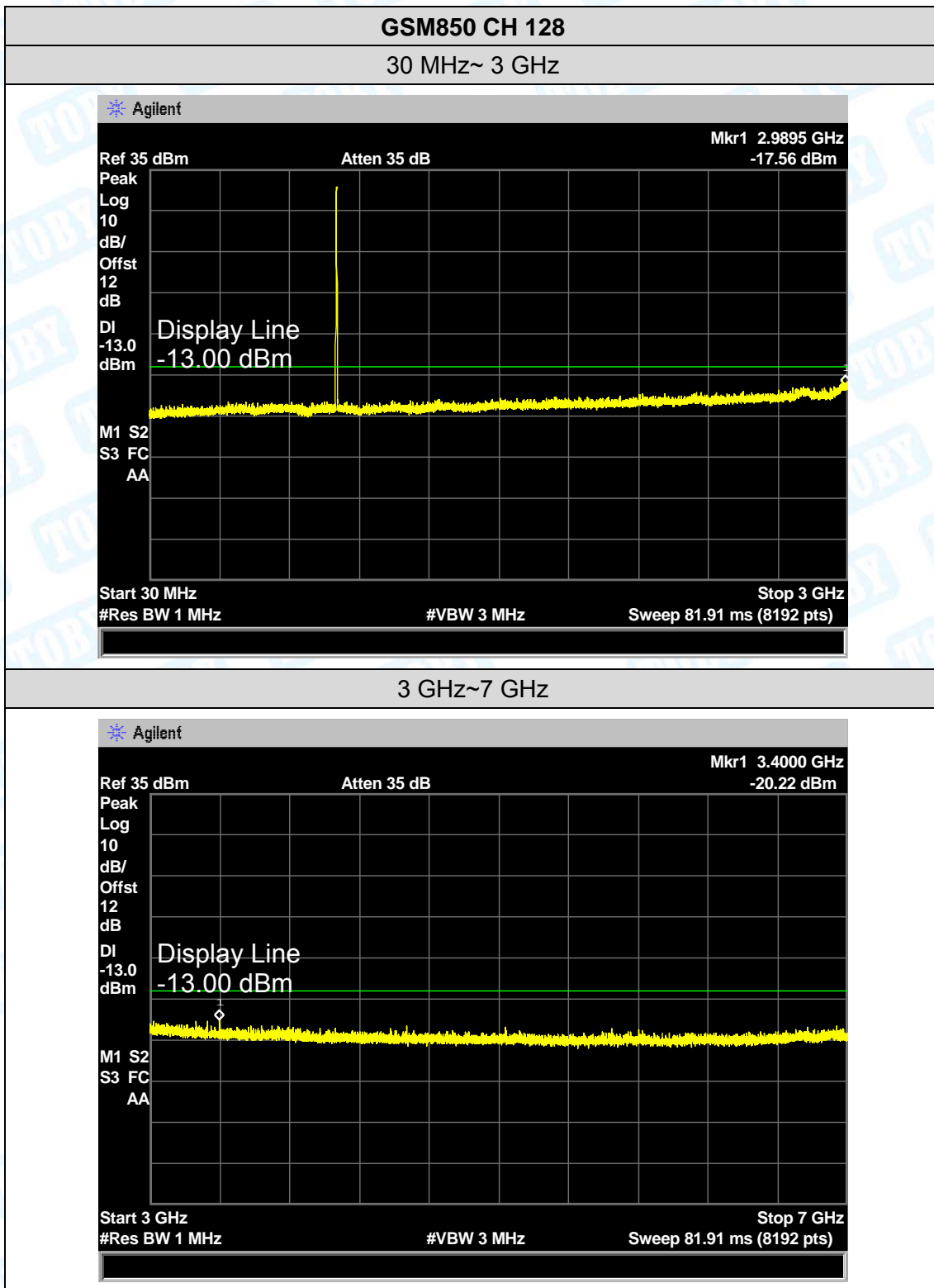

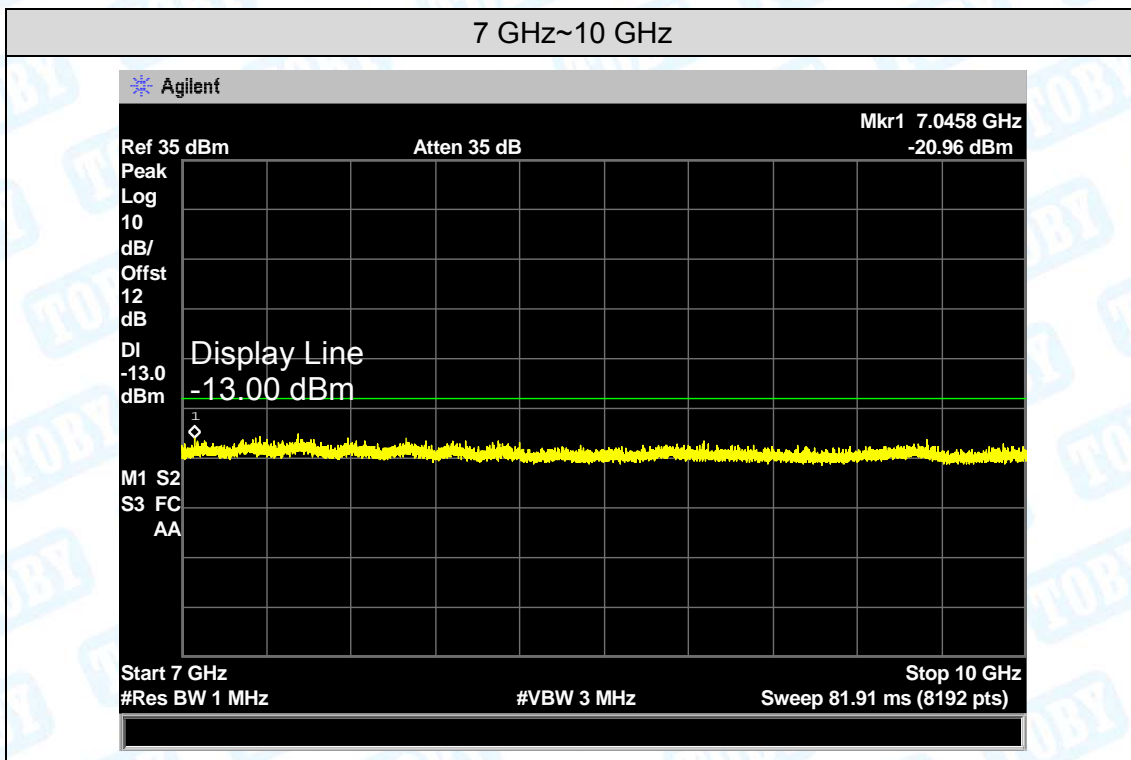

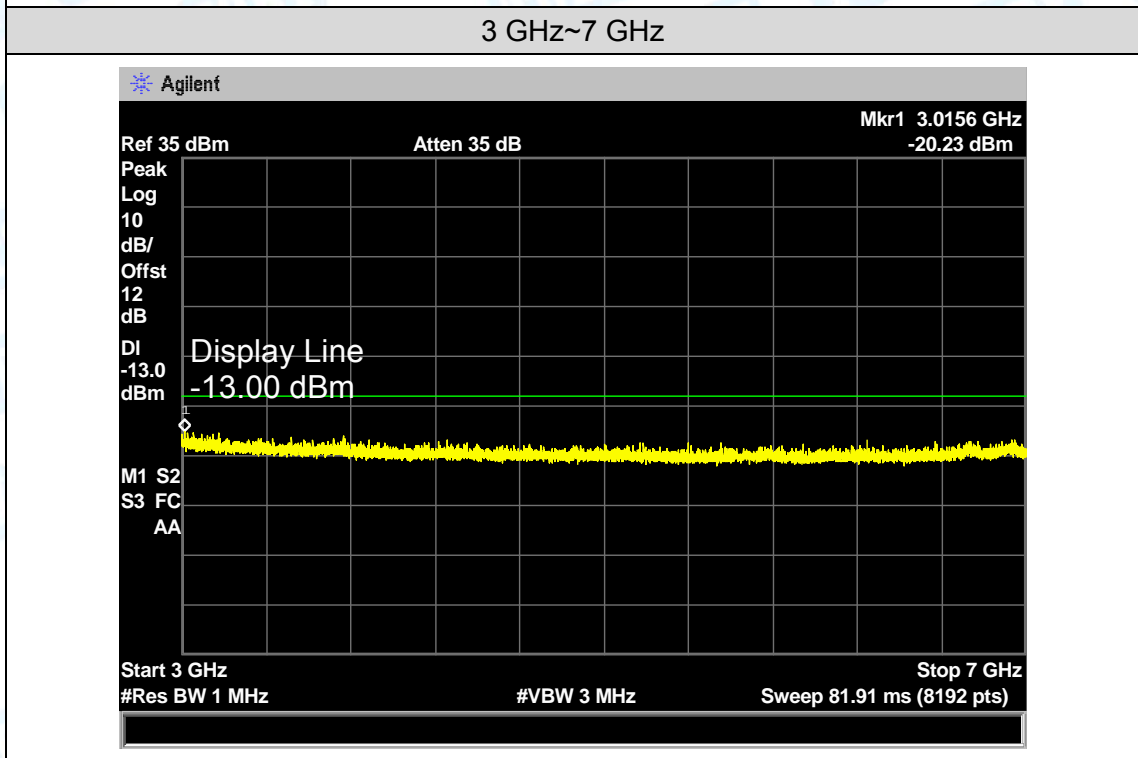
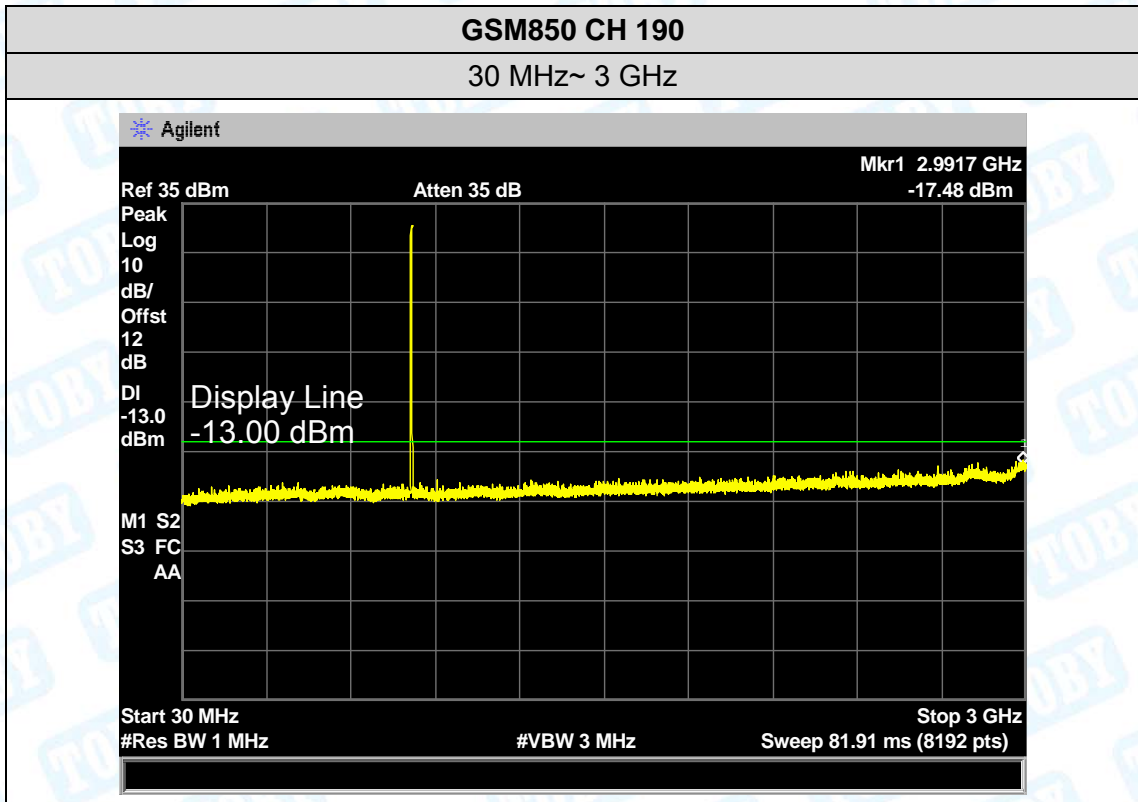

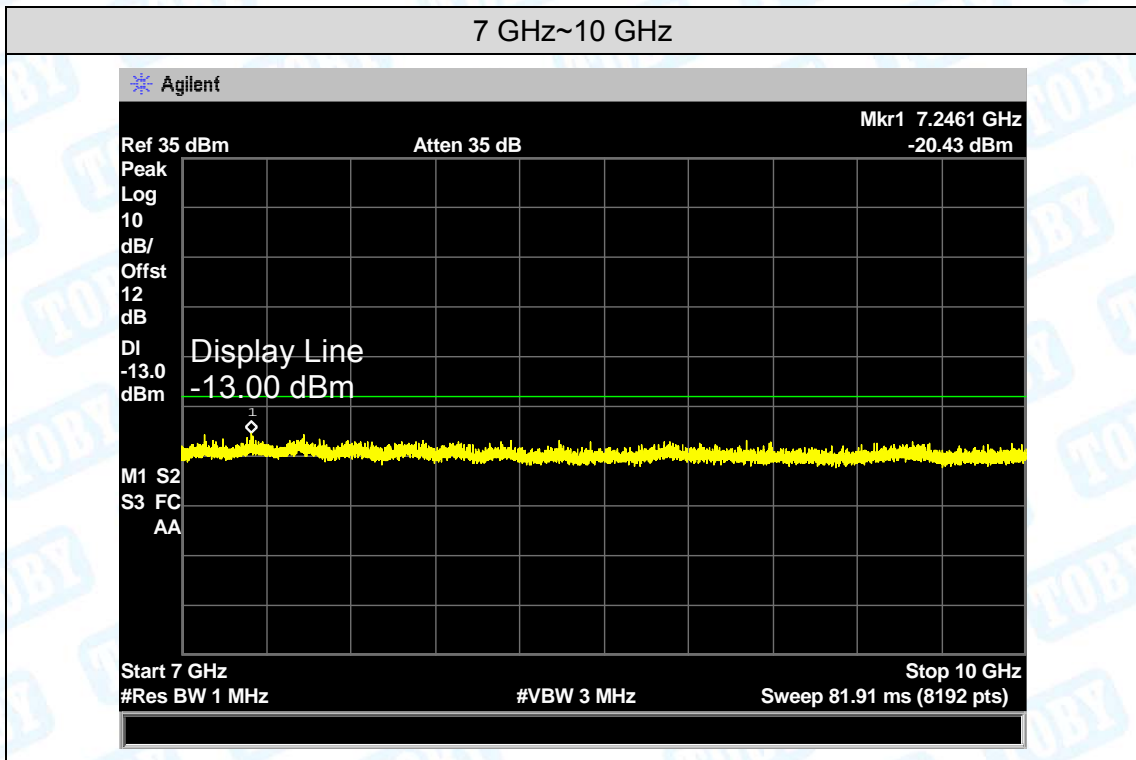

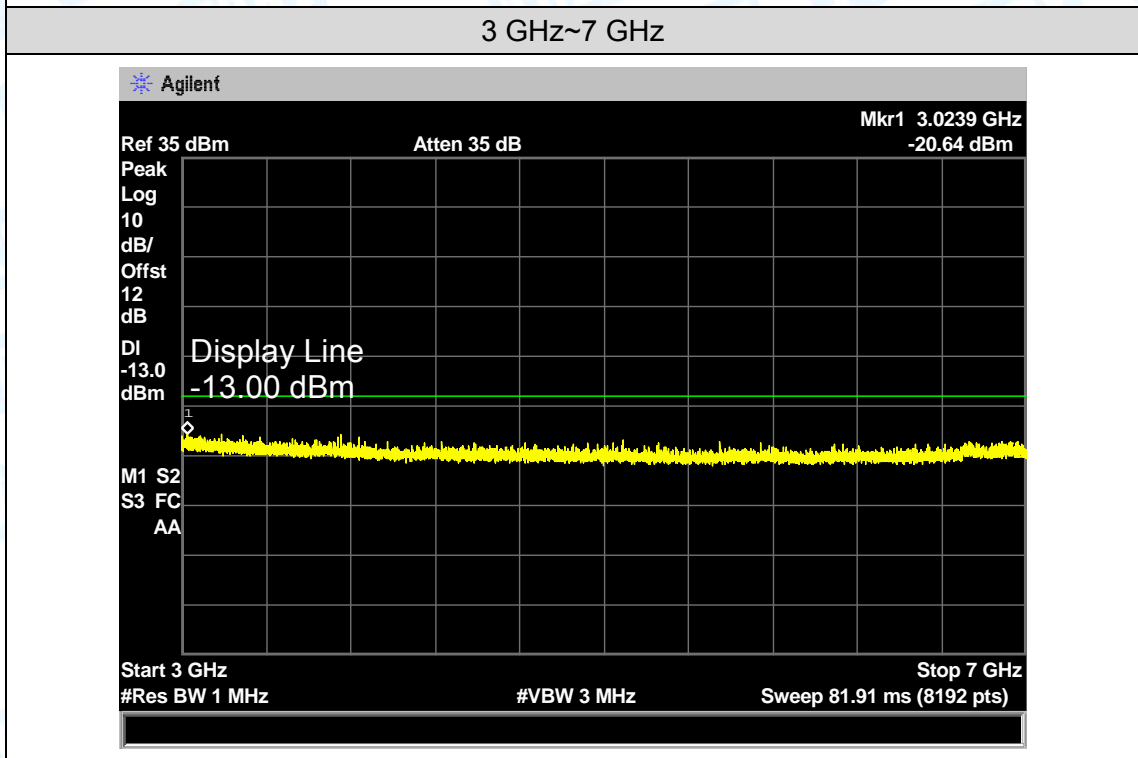
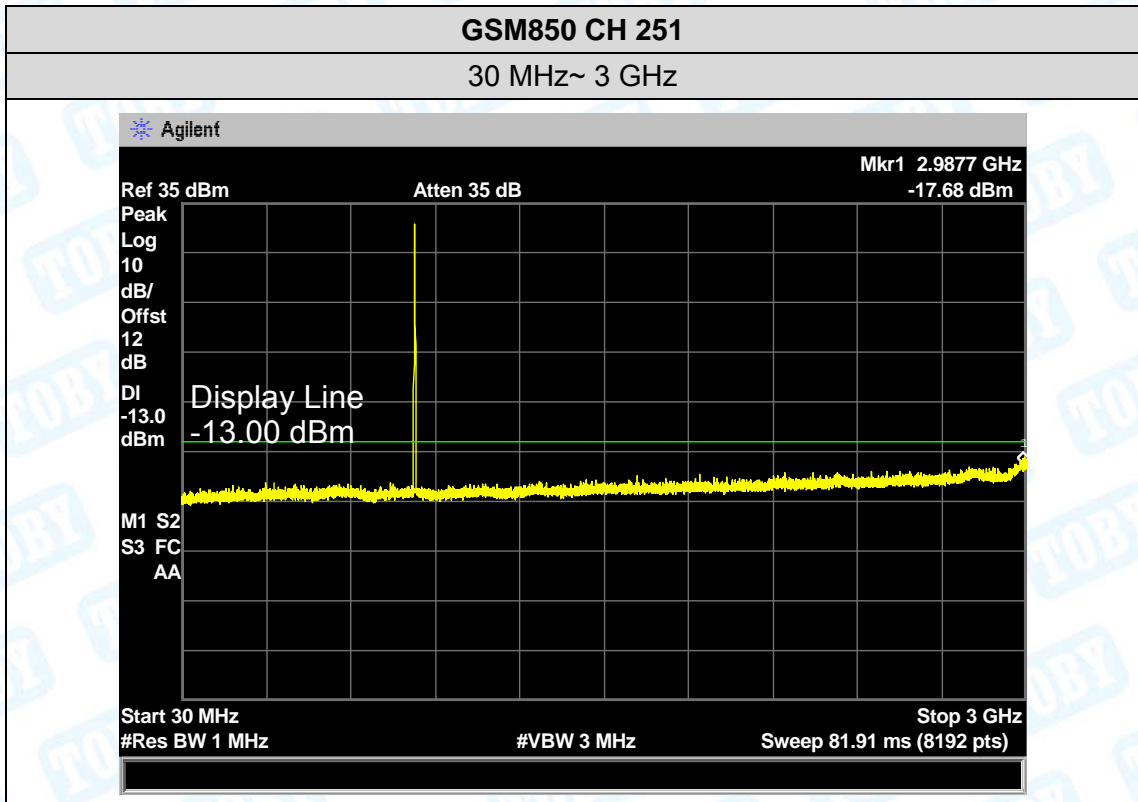

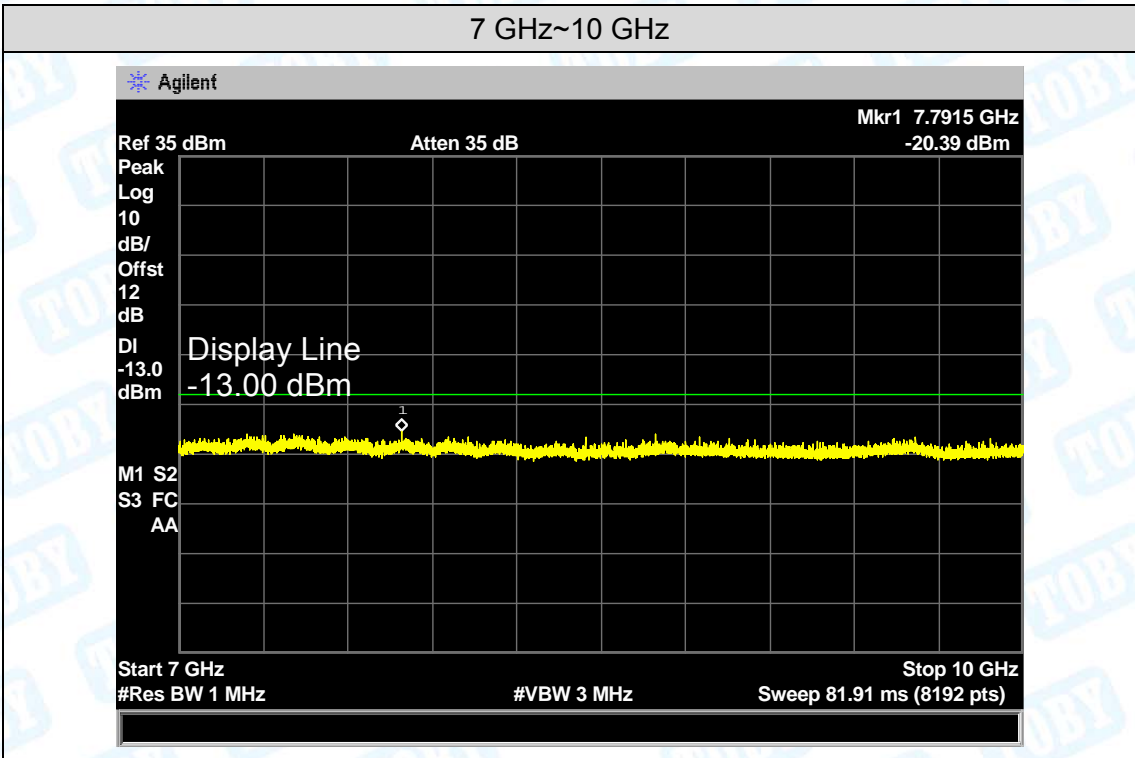

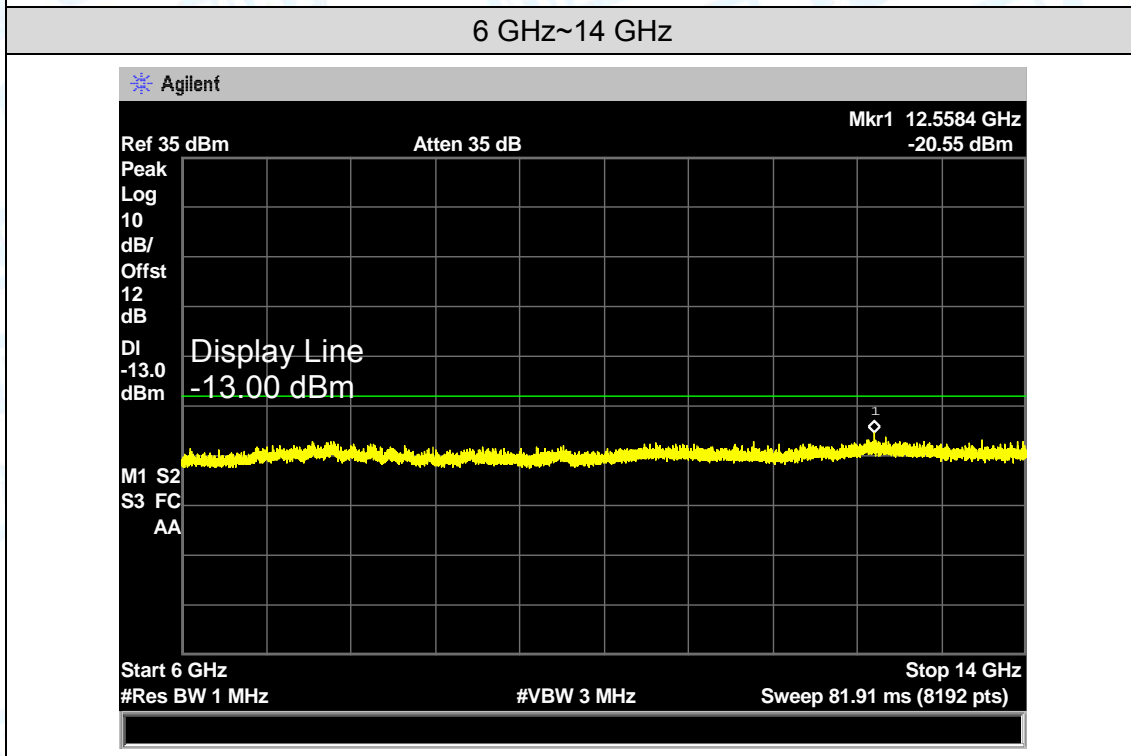
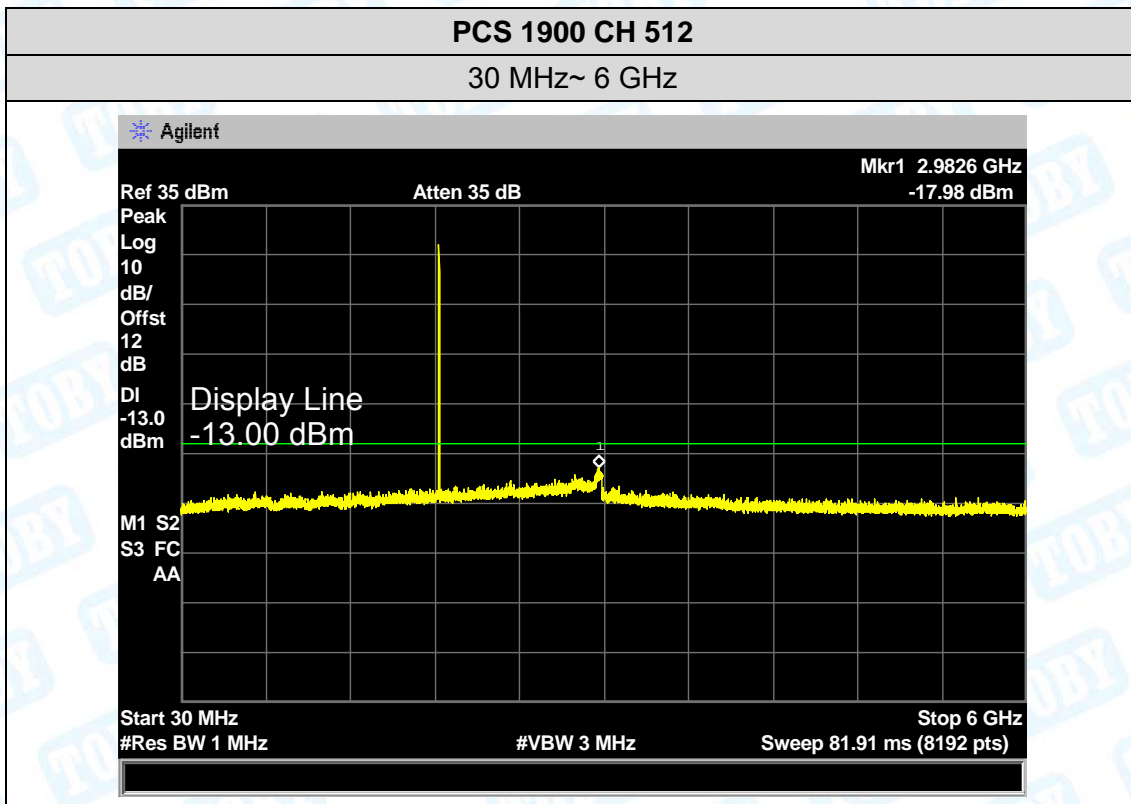

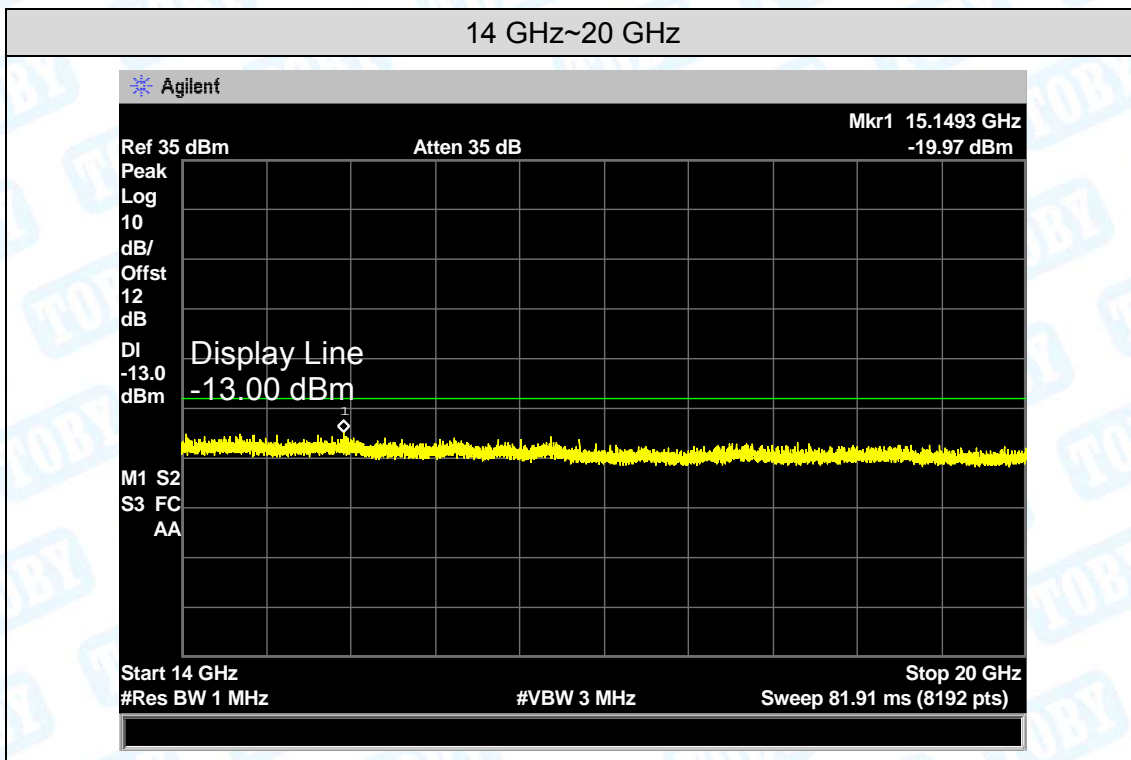

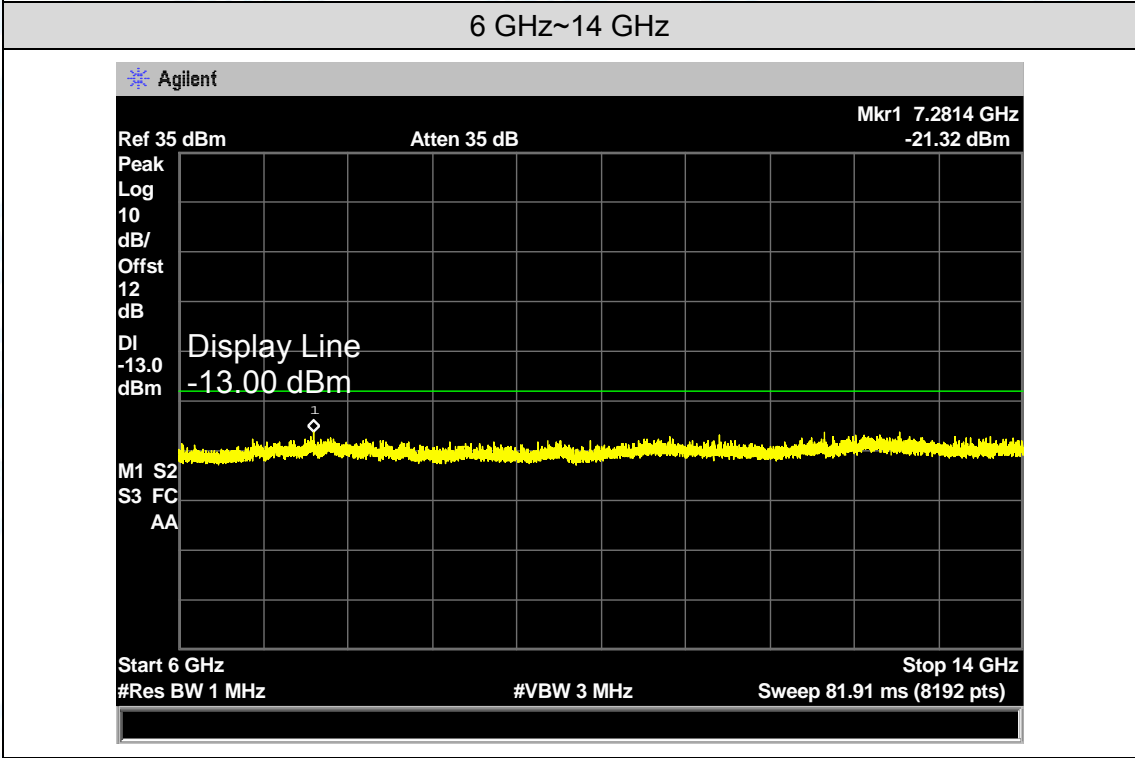
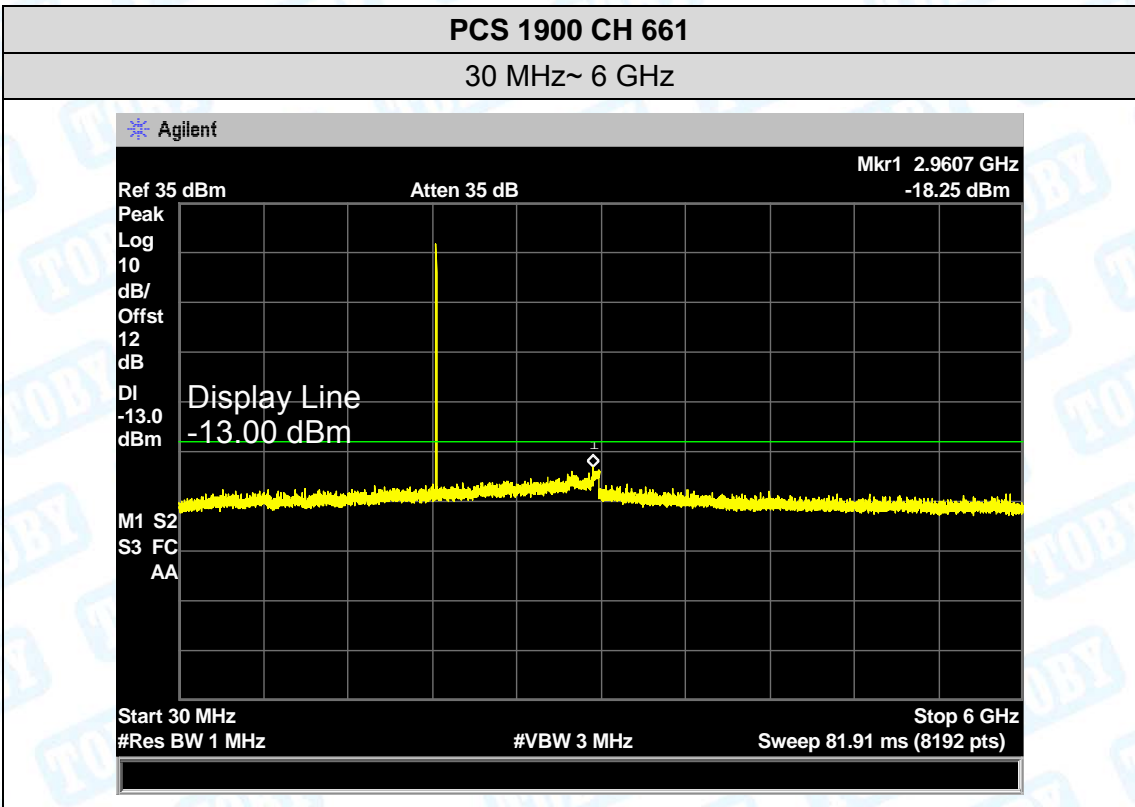

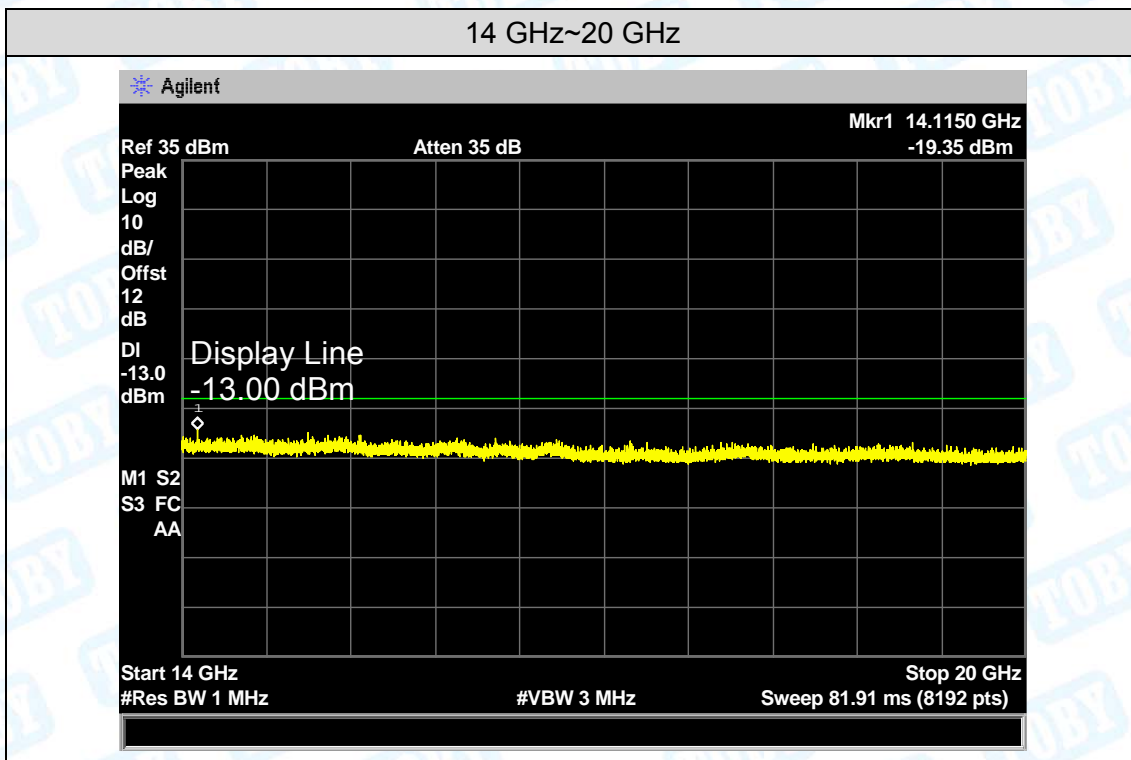

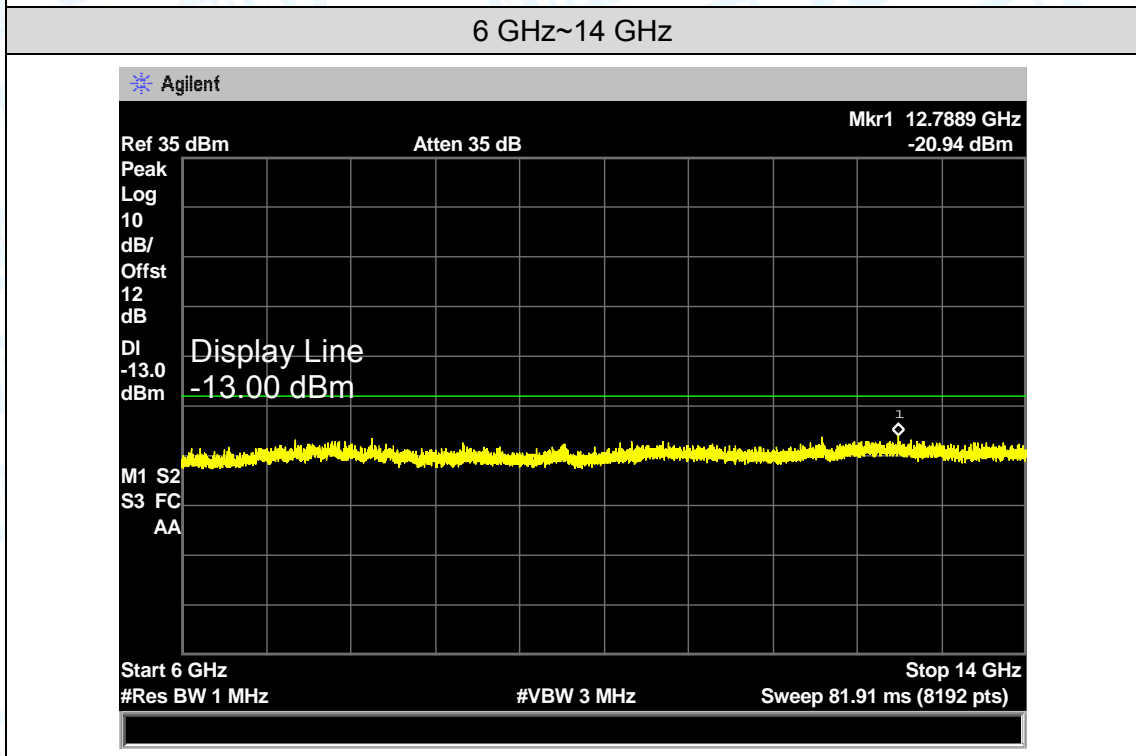
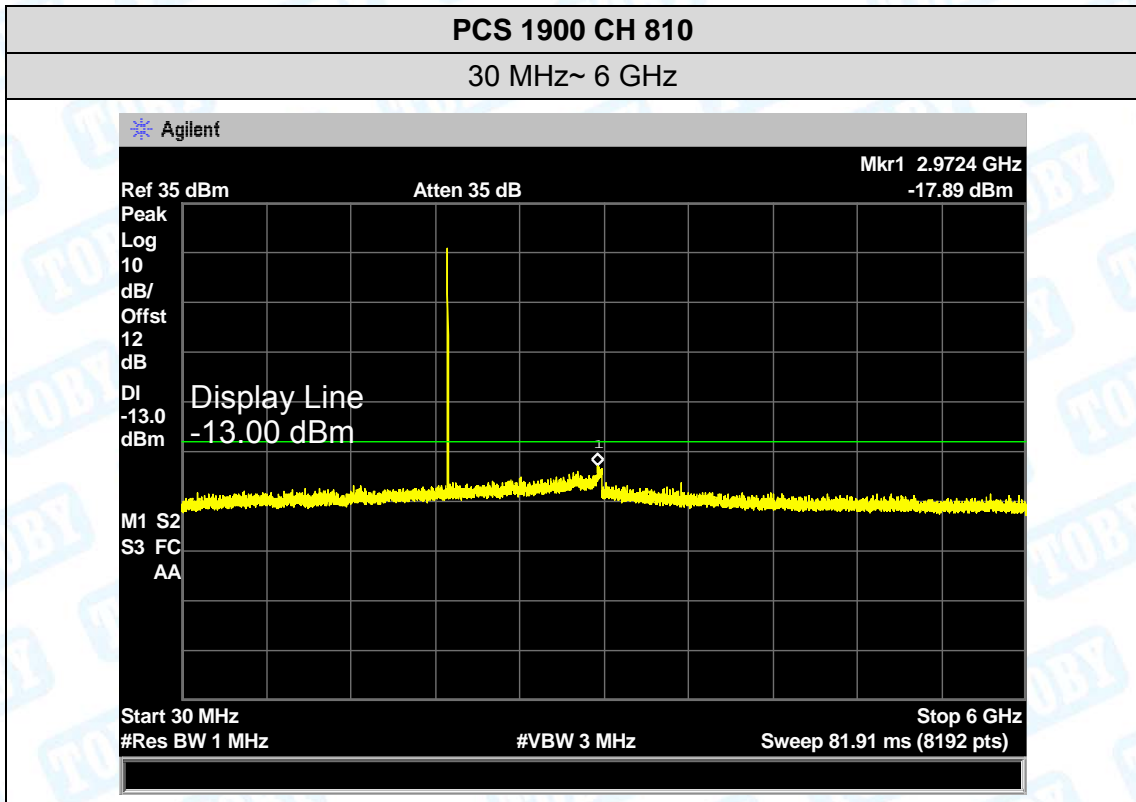

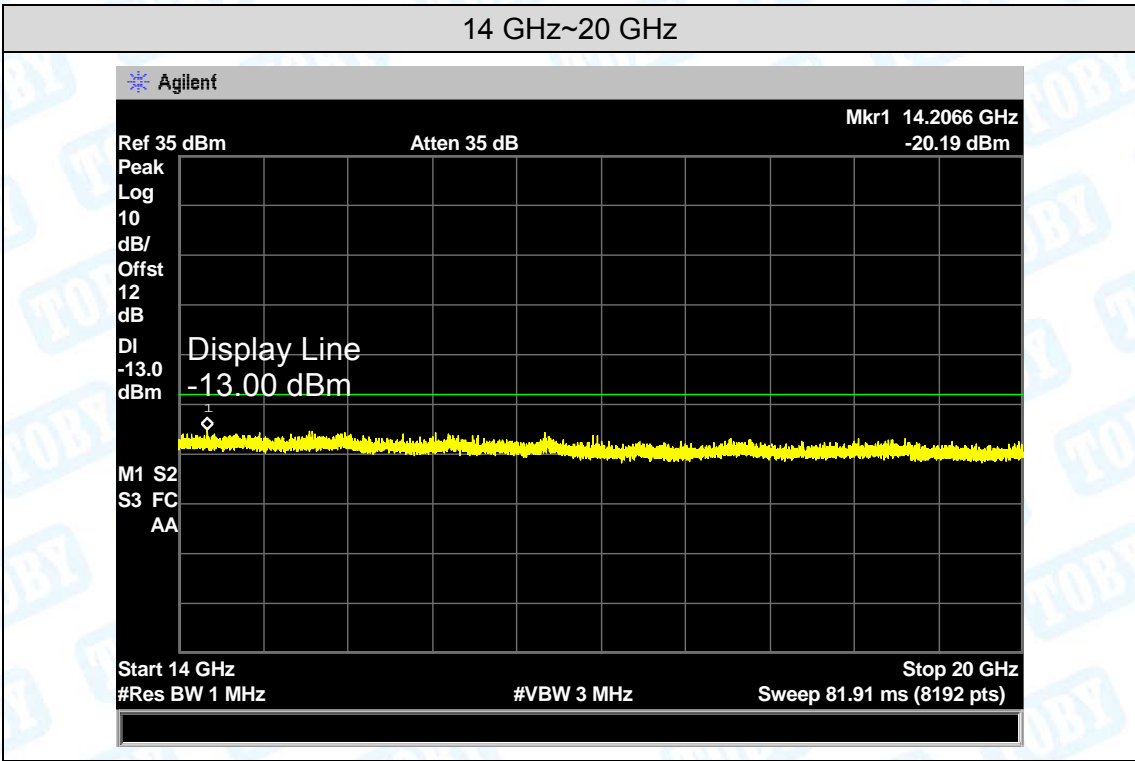

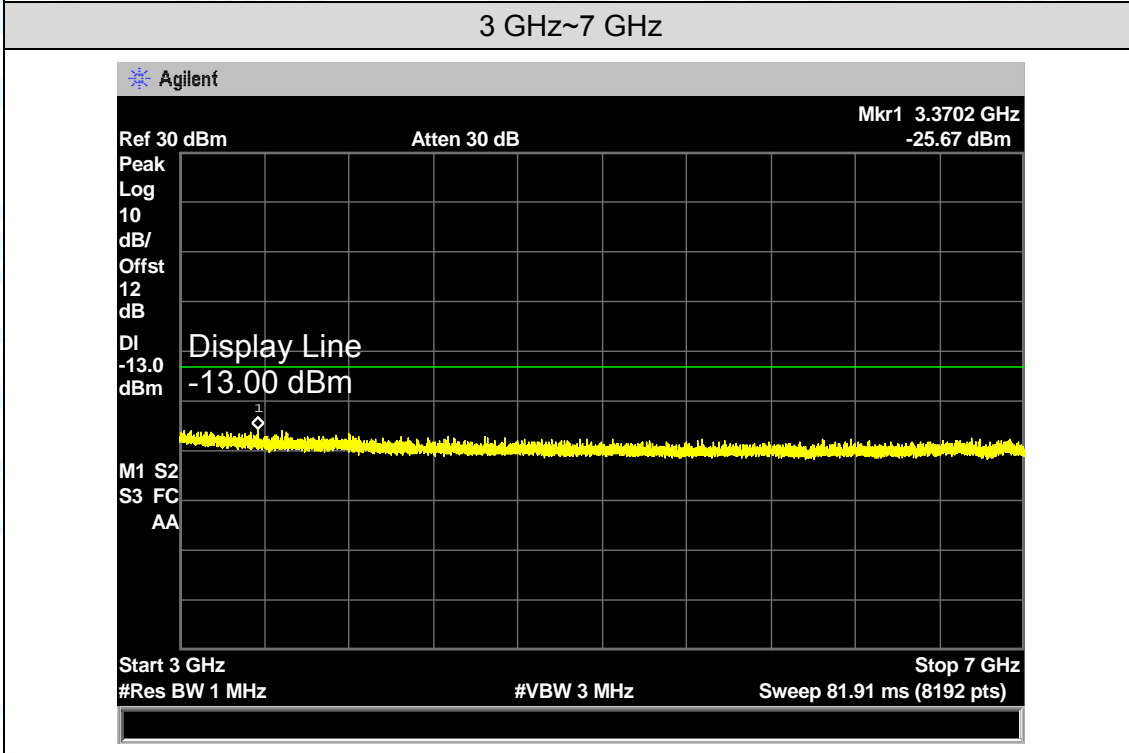
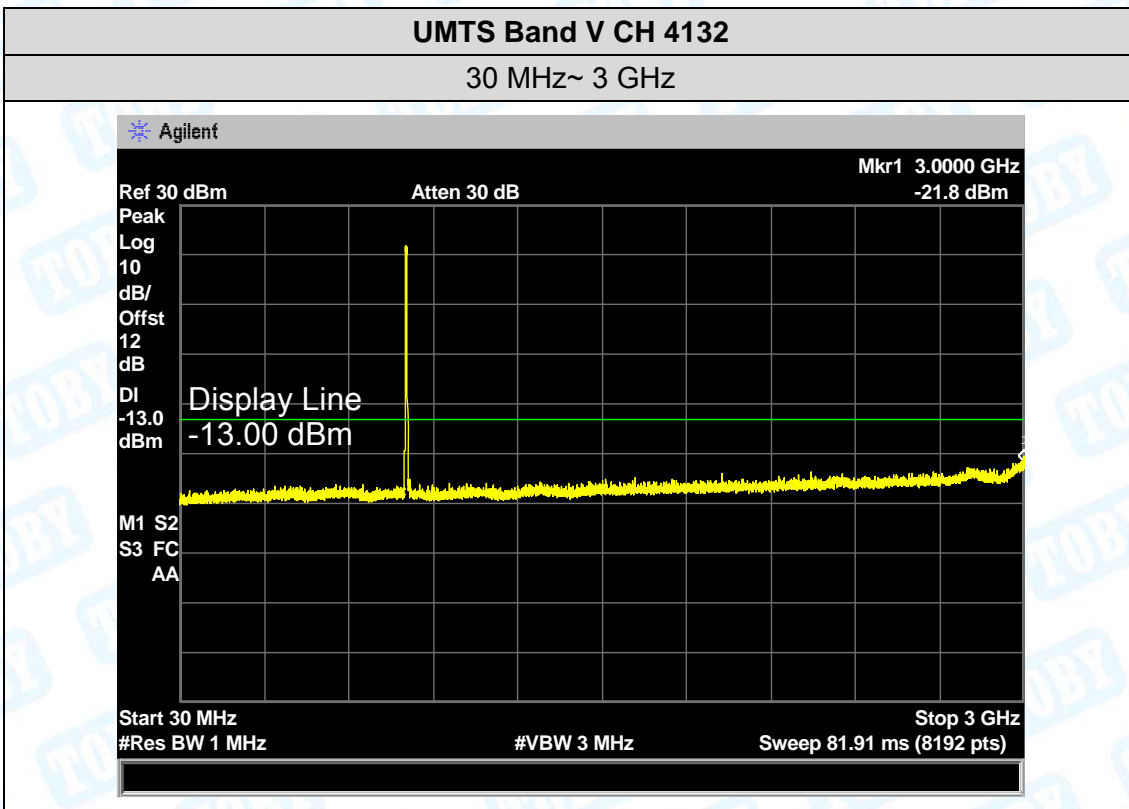

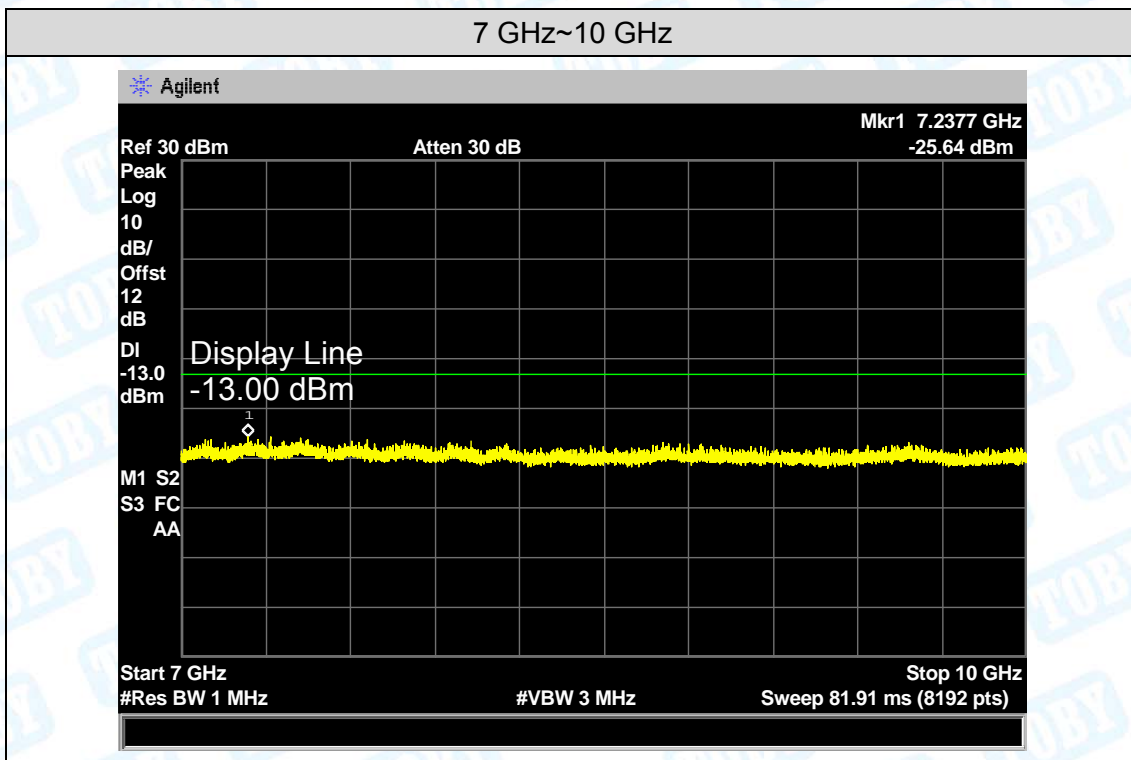

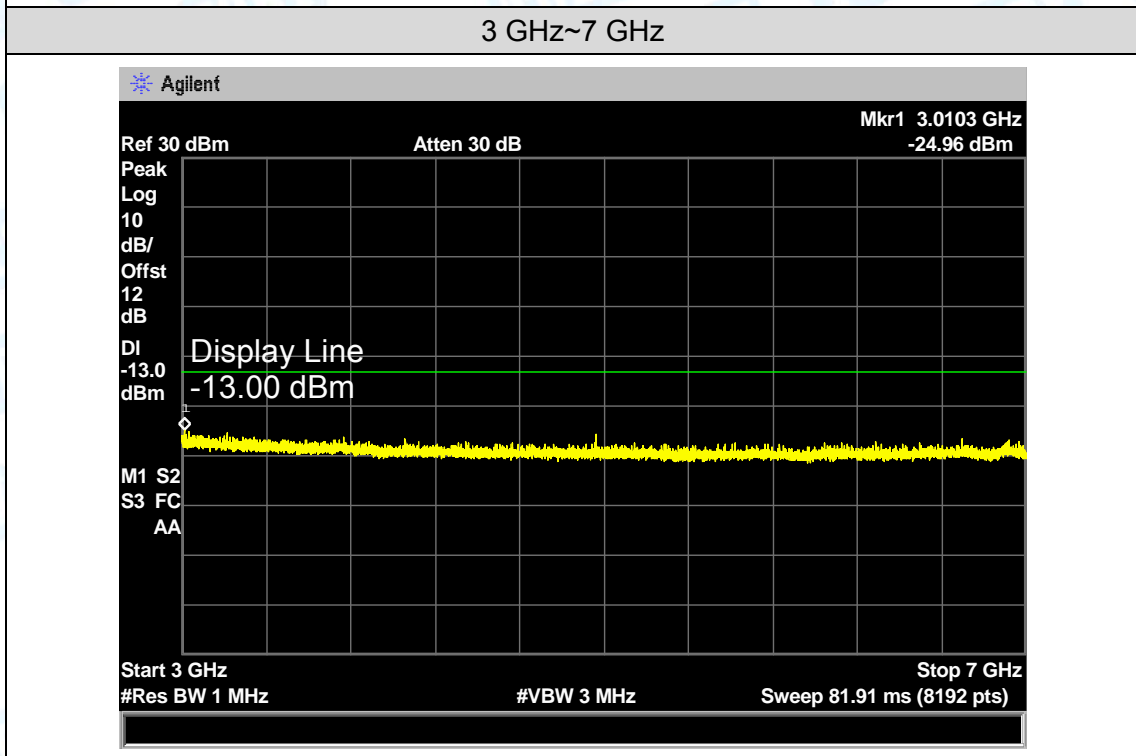
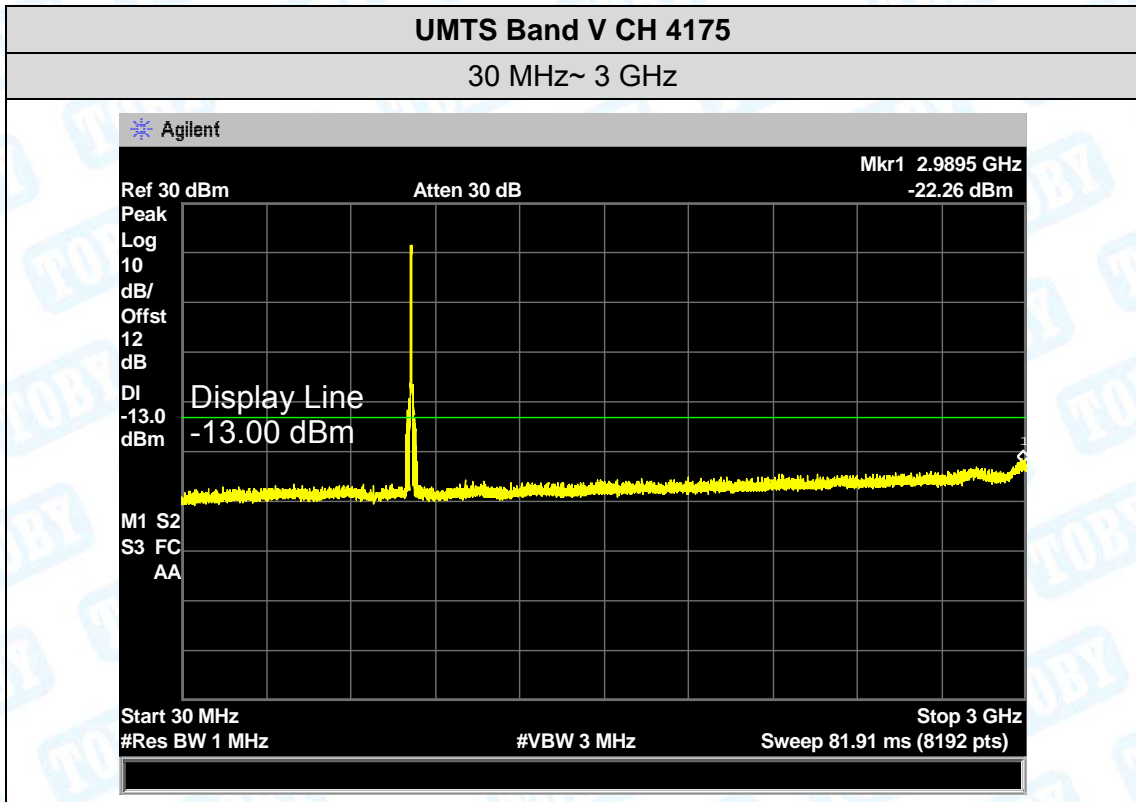

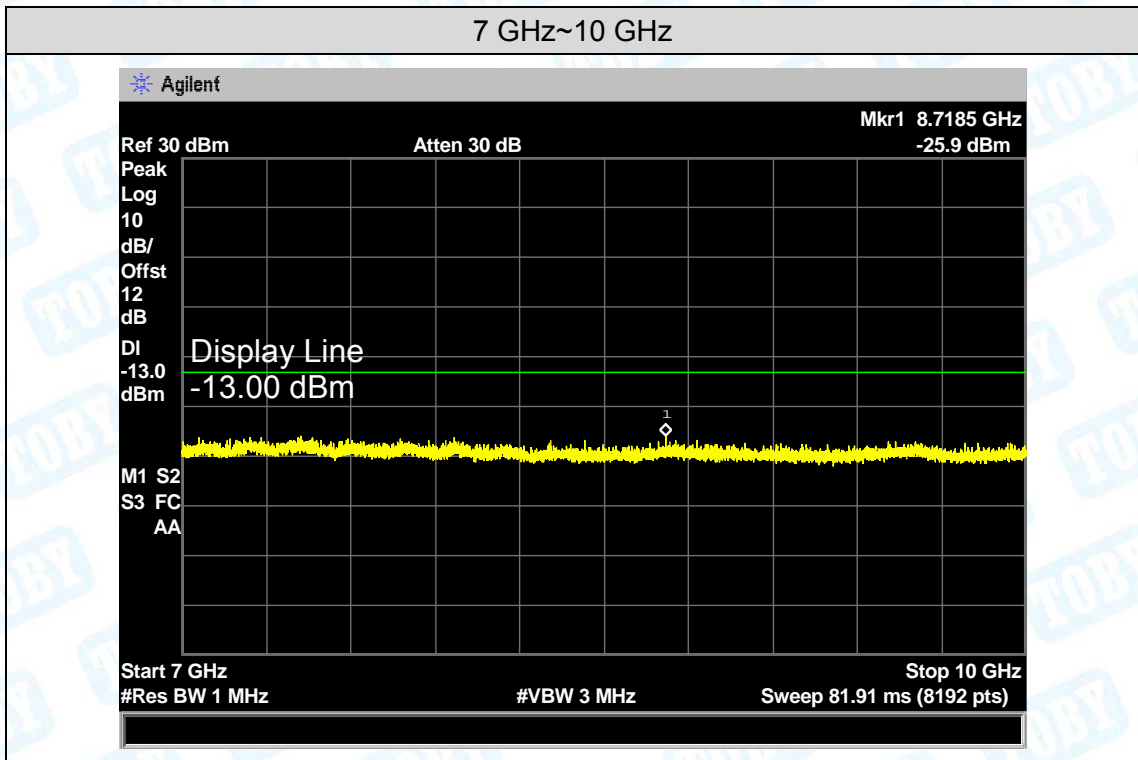

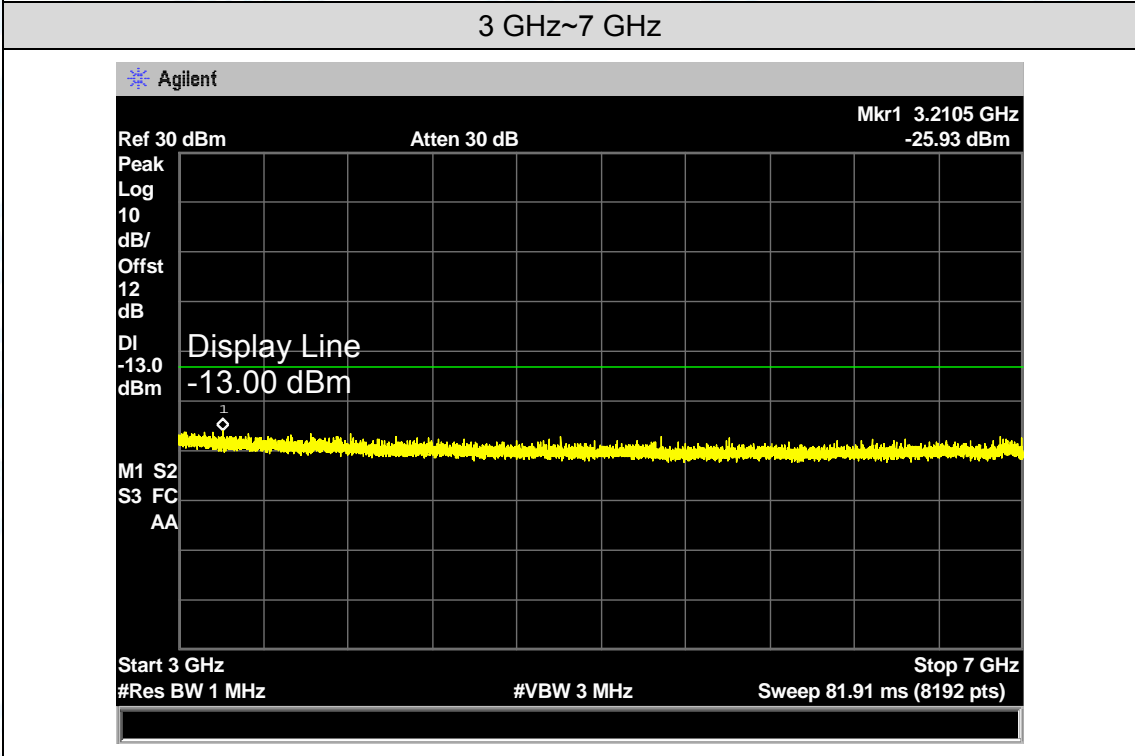
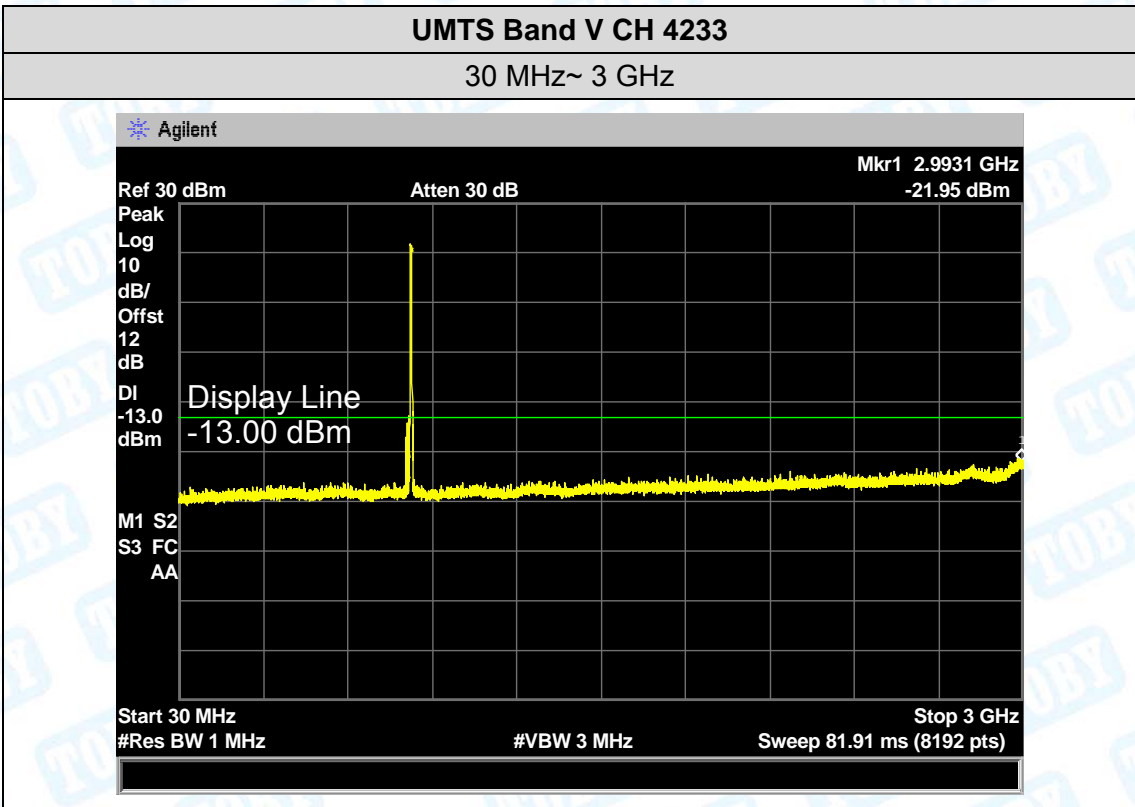

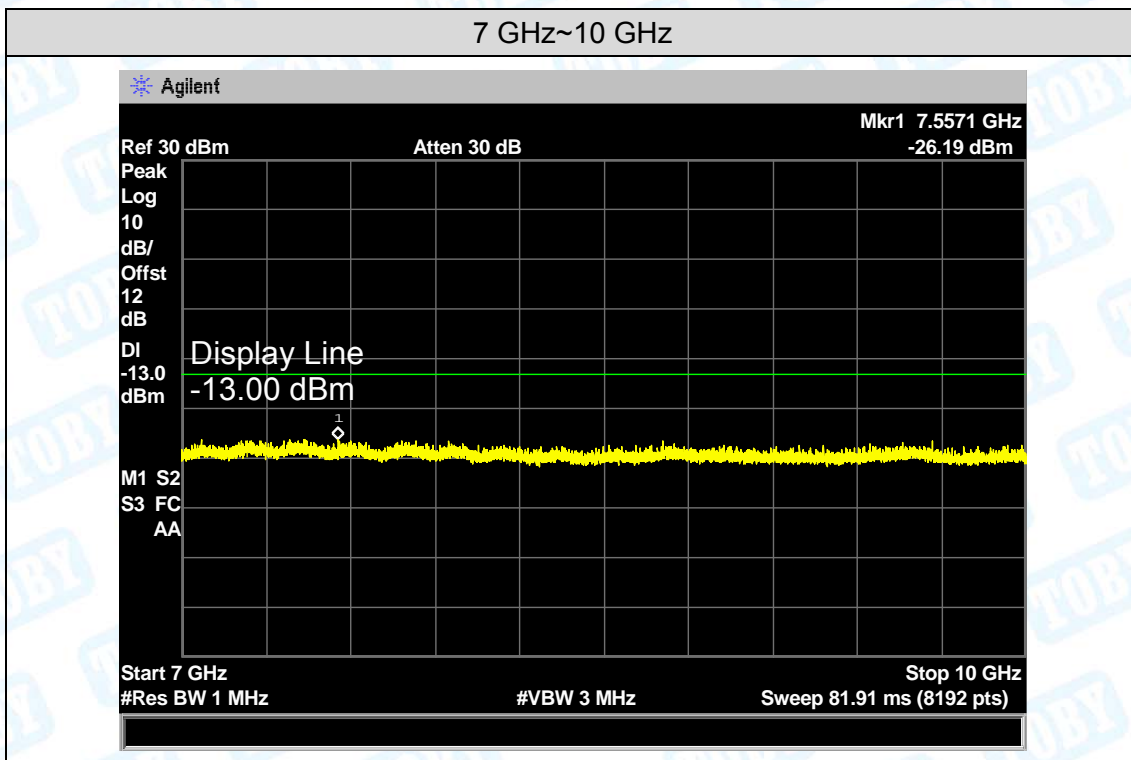

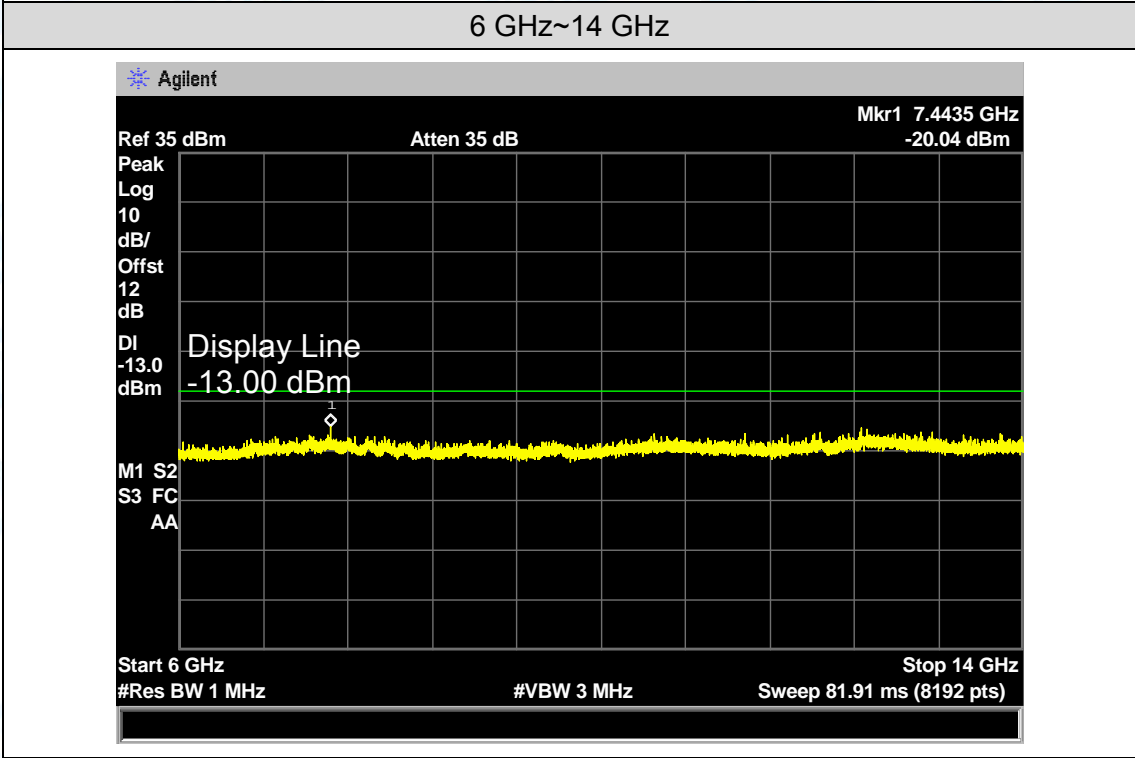
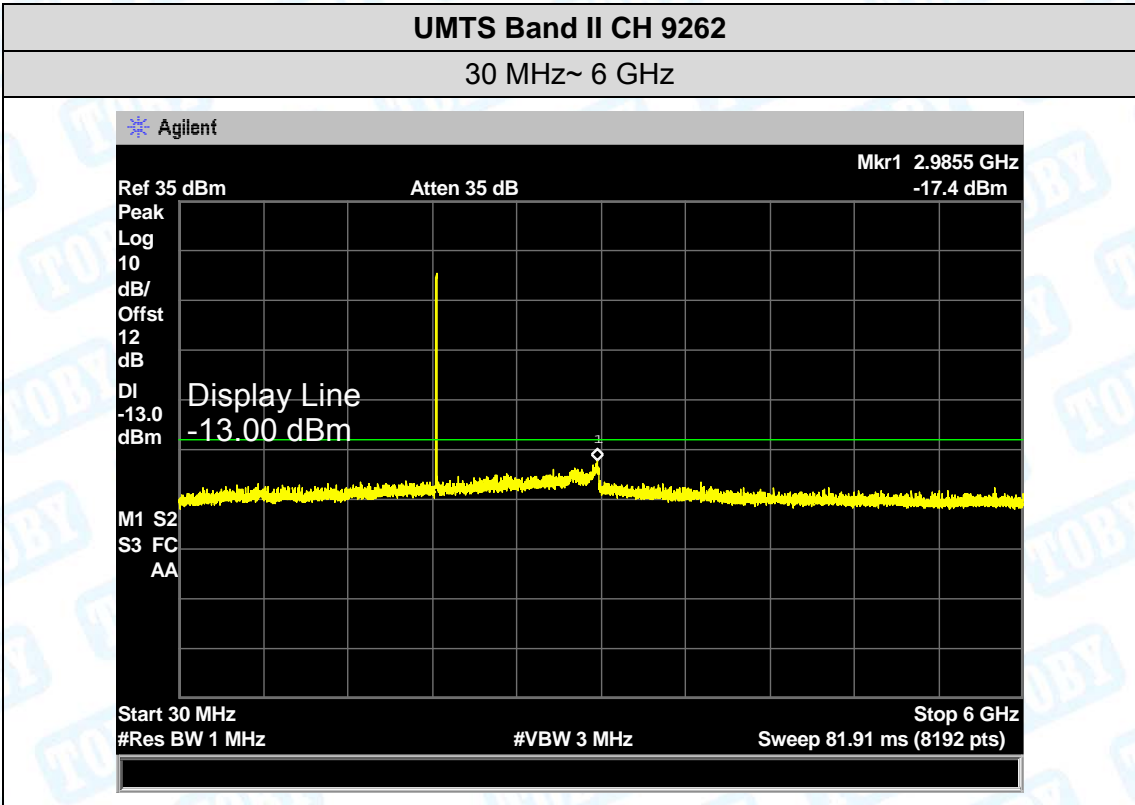

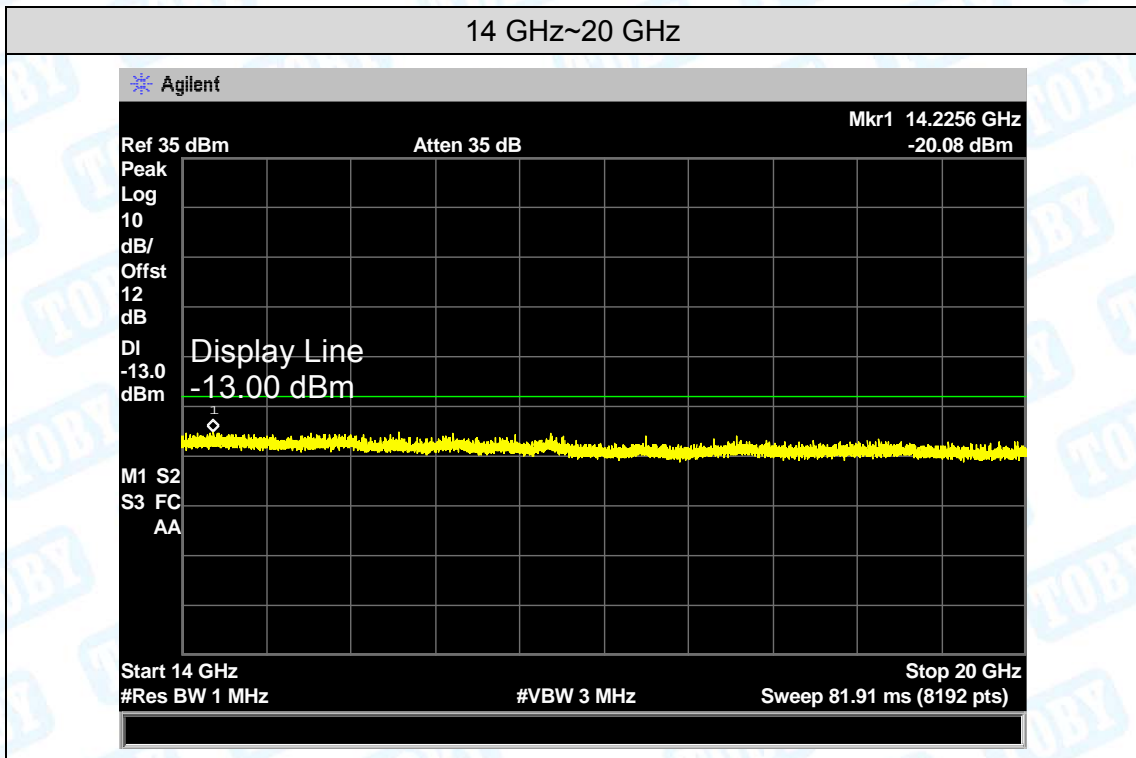

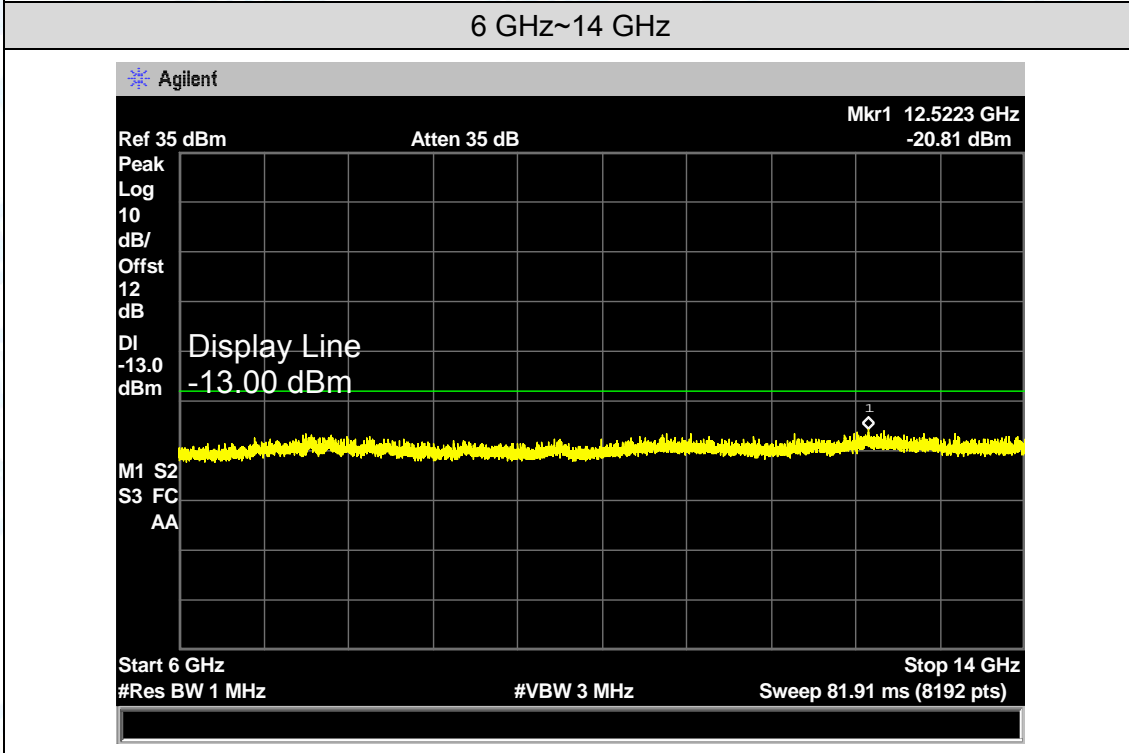
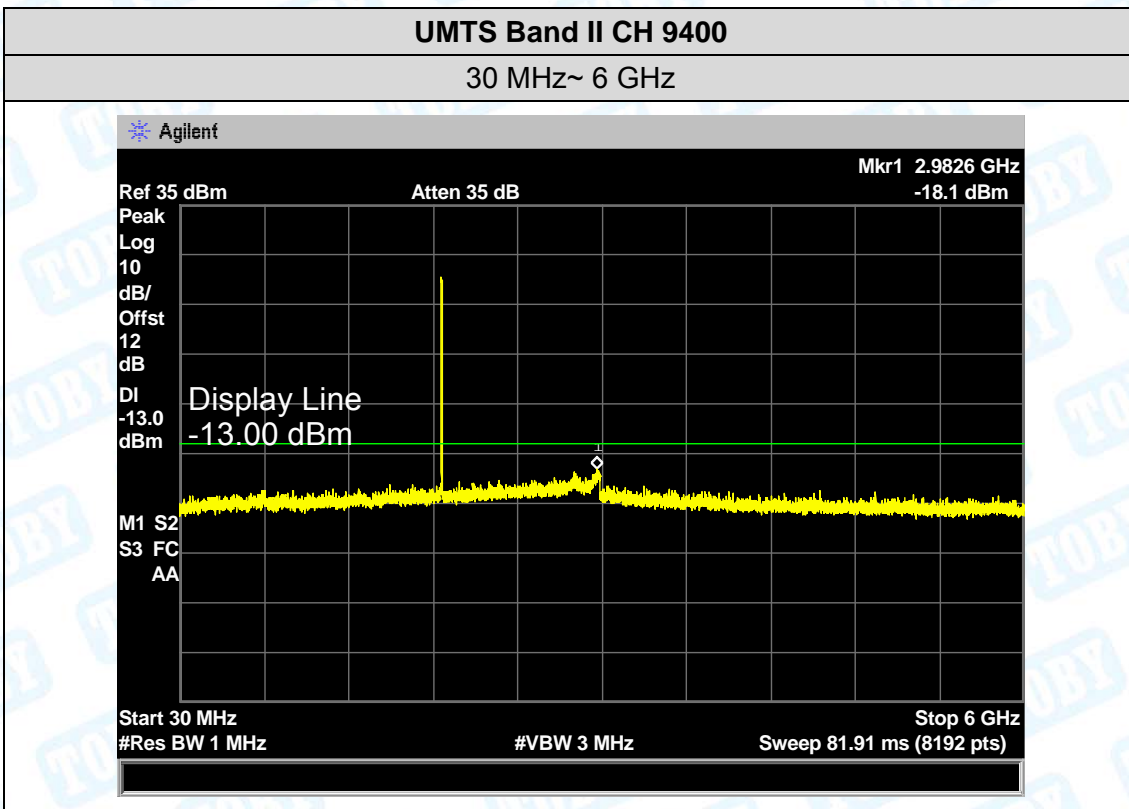

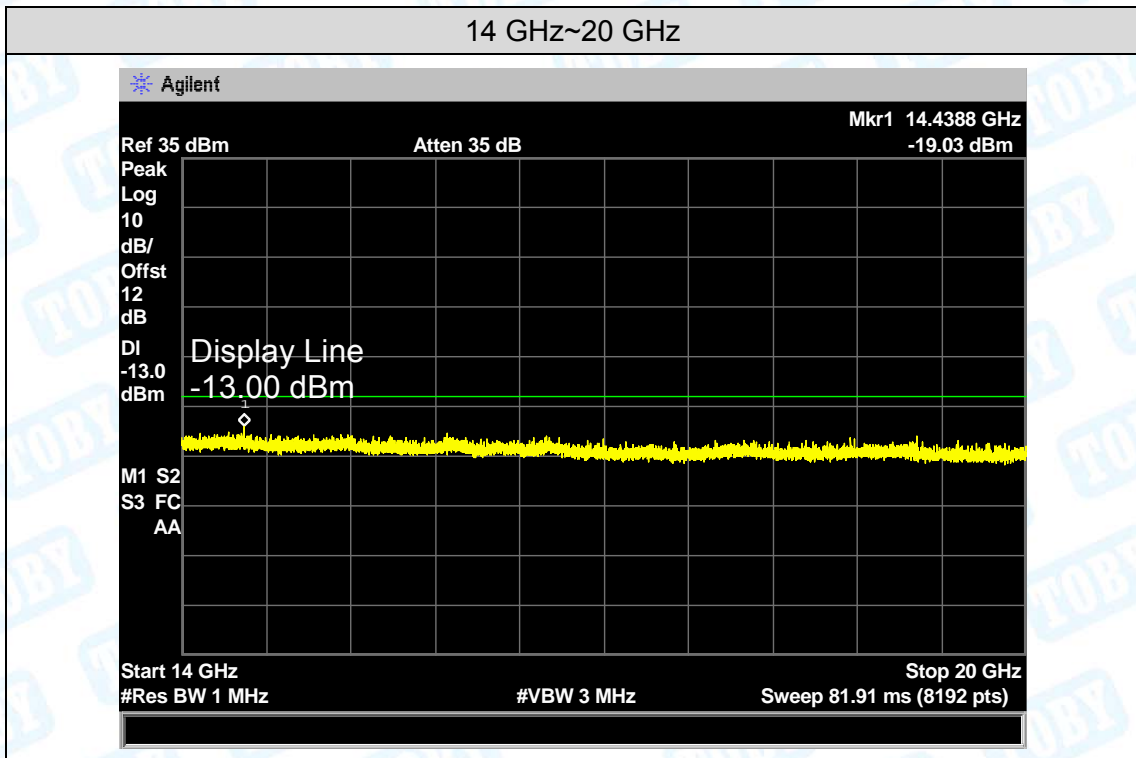

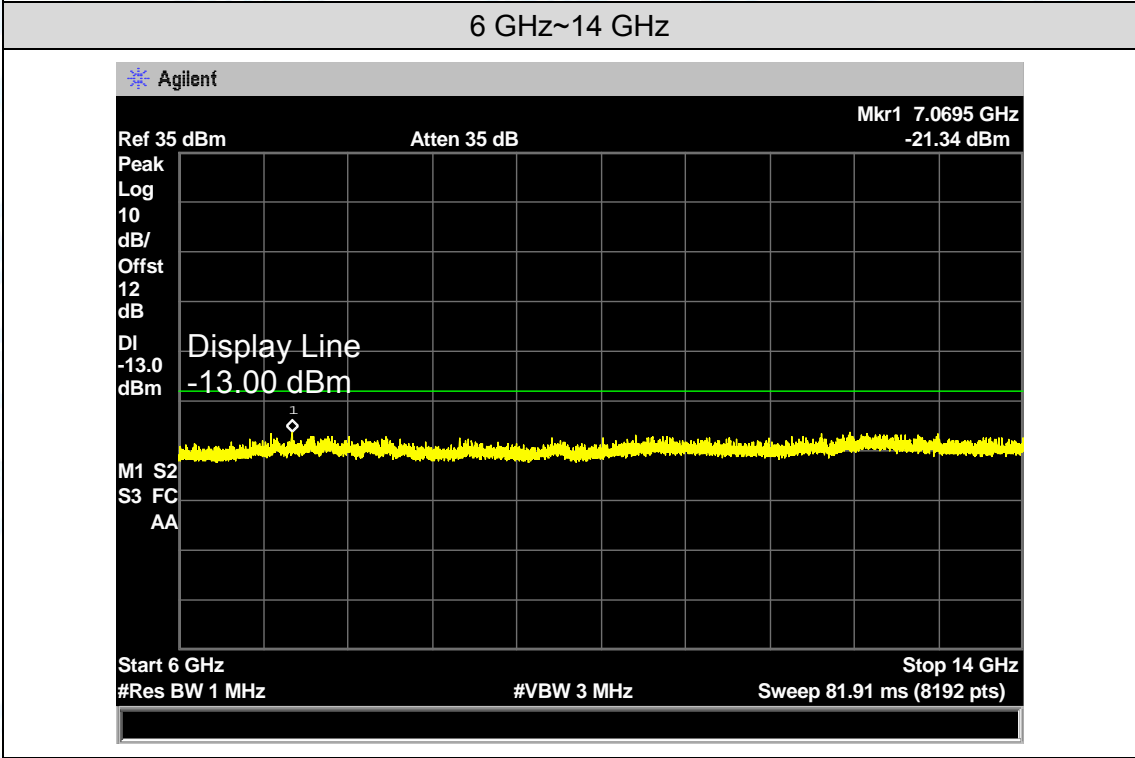
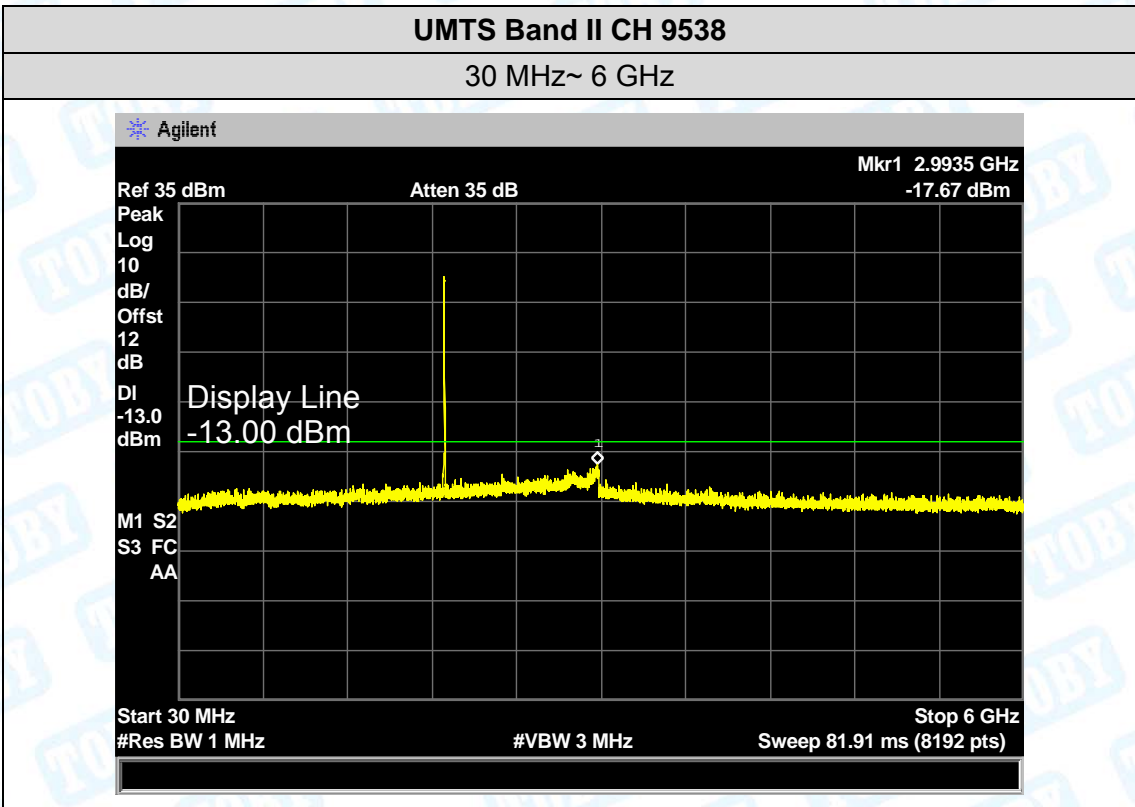

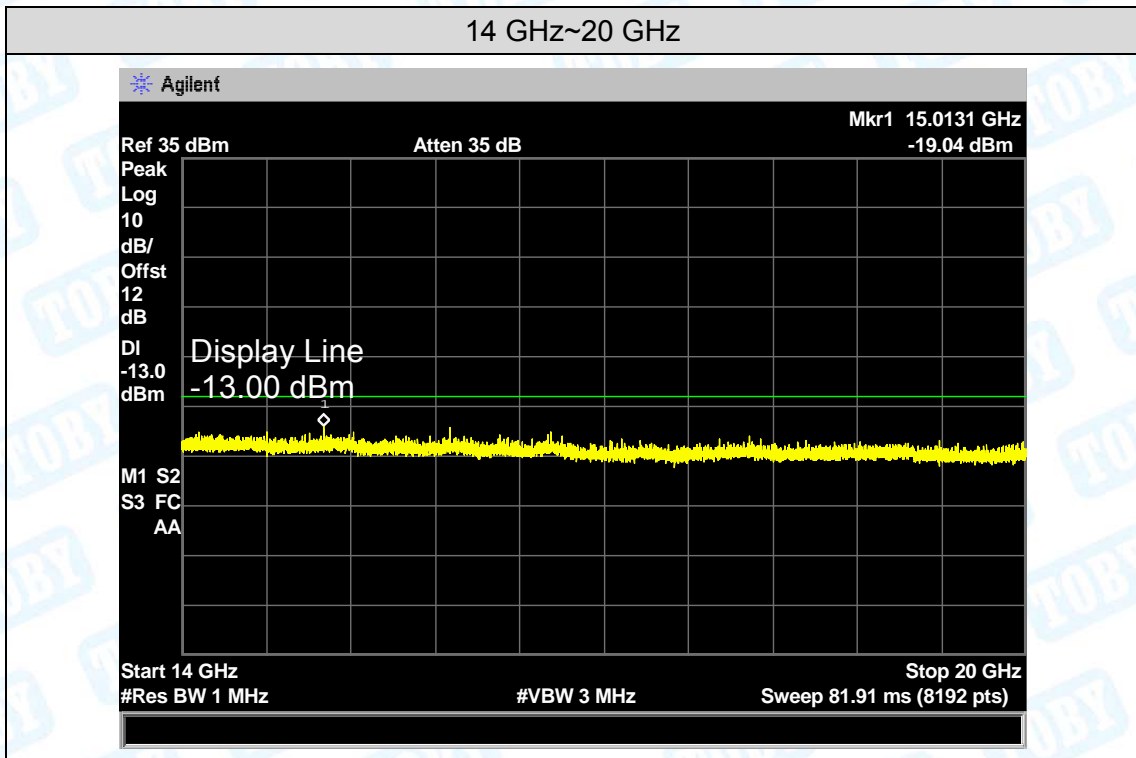

10. Band Edge Test

10.1 Test Standard and Limit

10.1.1 Test Standard

FCC Part 2: 2.1051, 2.1057

FCC Part 22H: 22.917(a)

FCC Part 24E: 24.238(a)

10.1.2 Test Limit

The power of any emission outside of the authorized operating frequency ranges must be attenuated below the transmitting power(P) by a factor of at least $43+10\log(P)$ dB. For all power levels +30 dBm to 0 dBm, this becomes a constant specification limit of -13 dBm.

10.2 Test Setup

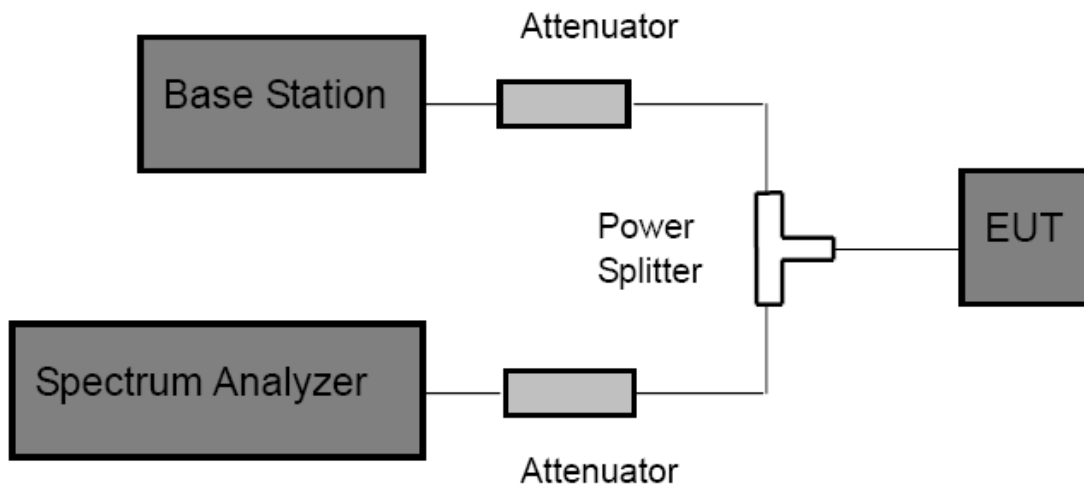

10.3 Test Procedure

- (1) The EUT was directly connected to the spectrum analyzer and Base station via power splitter as show in the block diagram above.
- (2) Spectrum Setting:
 GSM and PCS: $RBW \geq 1\%$ 26db bandwidth, $VBW=3$ RBW, Span 1 MHz, Detector: Peak Mode.
 WCDMA: $RBW \geq 1\%$ 26db bandwidth, $VBW=3$ RBW, Span 10 MHz, Detector: Peak Mode.
- (3) The band edges of low and high channels for the highest RF powers were measured.

10.4 EUT Operating Condition

The EUT was continuously connected with the Base station and transmitting in the max power during the test.

10.5 Test Data

Please refer the following plots:

Band edge emission:

Test Mode:	GSM850
------------	--------

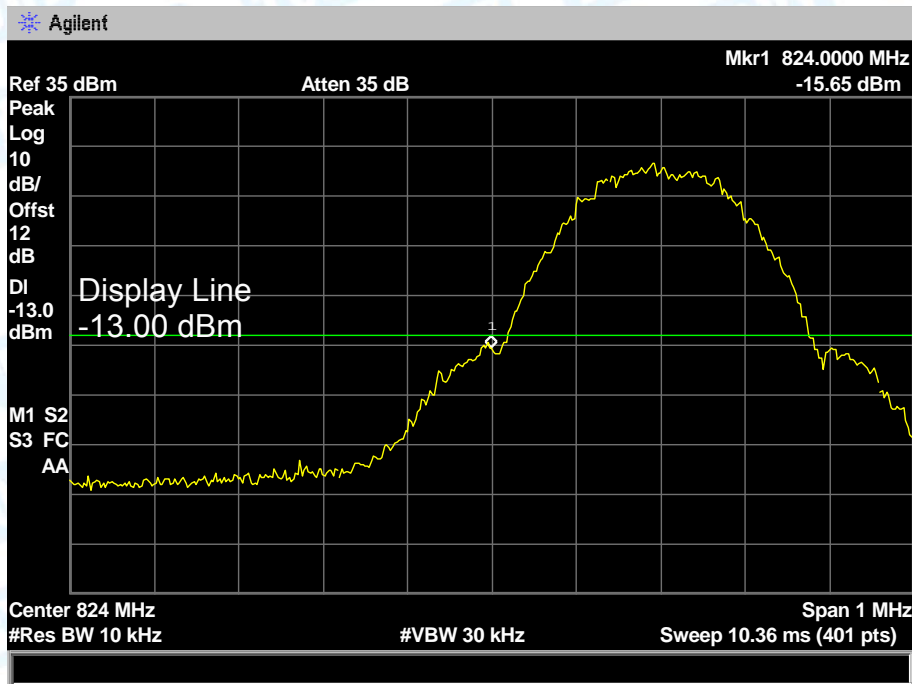

Lowest channel

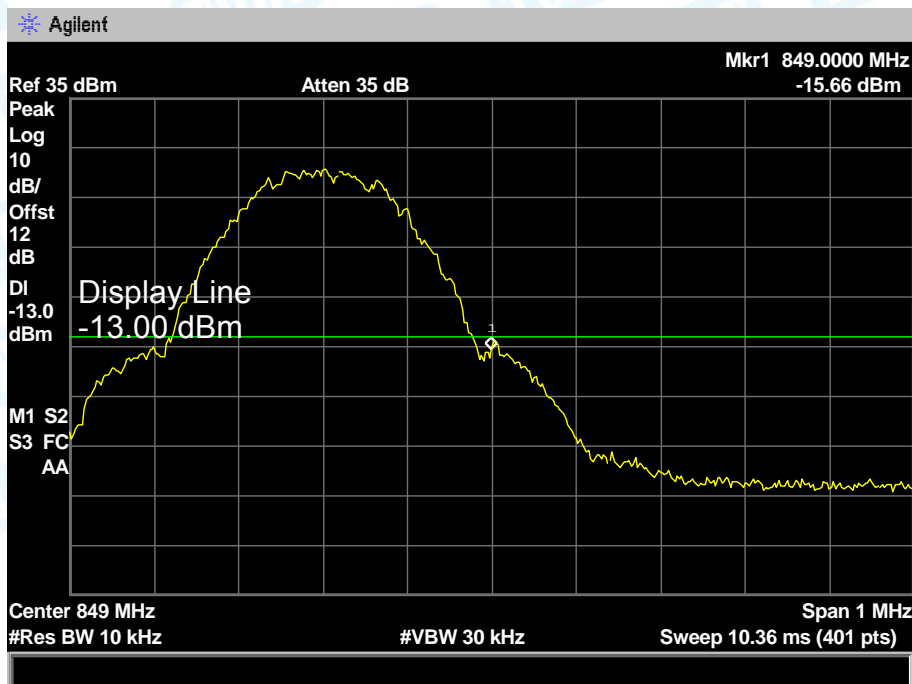

Highest channel

Test Mode: GPRS850

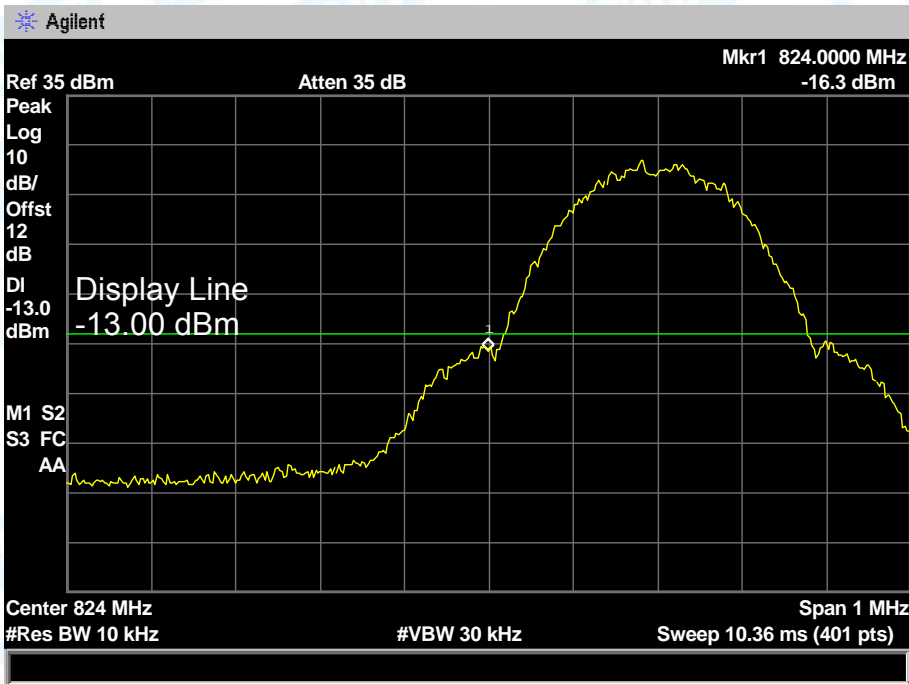

Lowest channel

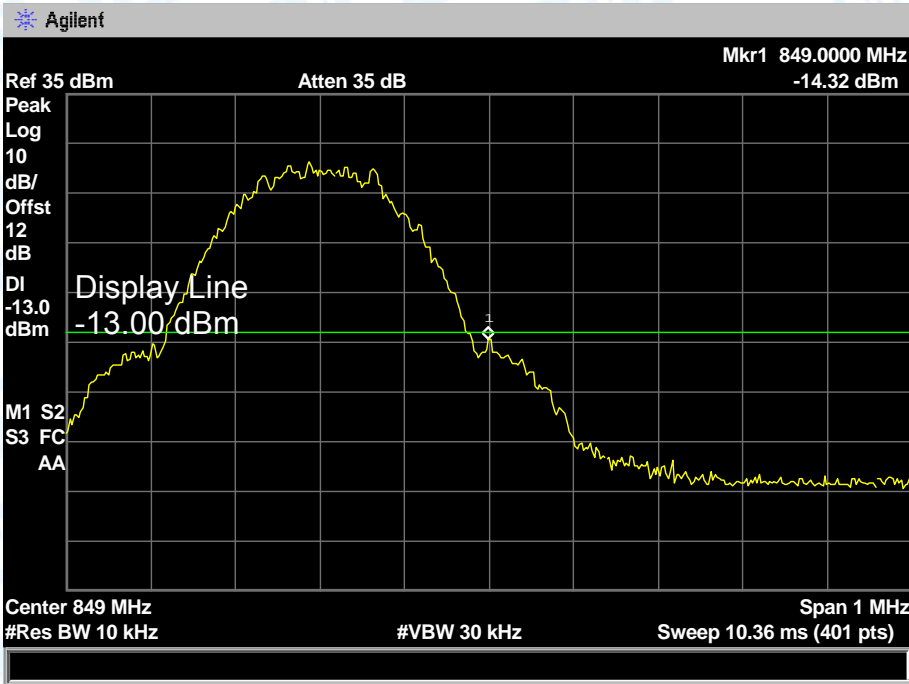

Highest channel

Test Mode:	EDGE850
------------	---------

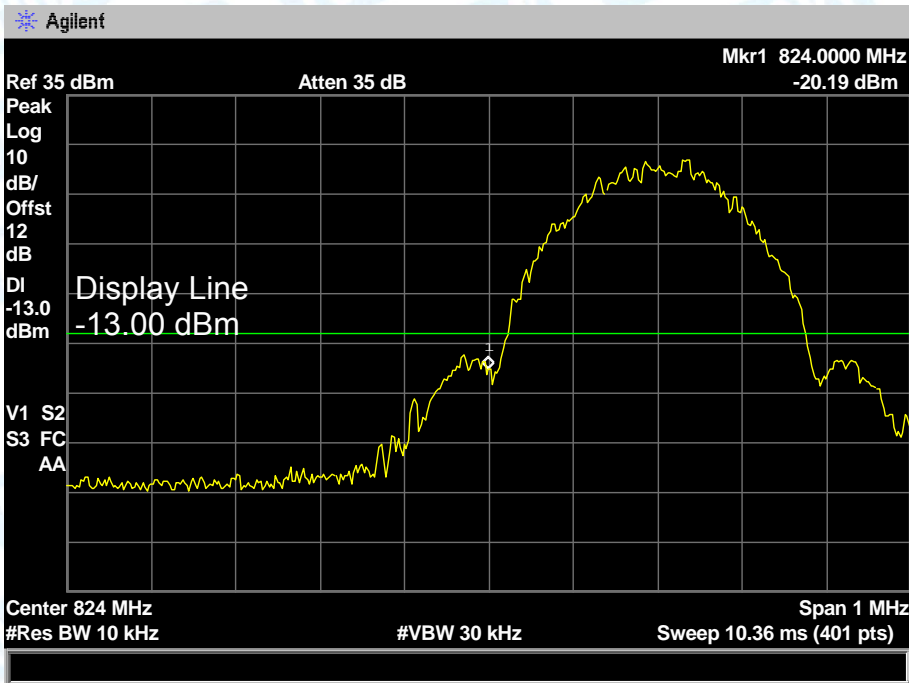

Lowest channel

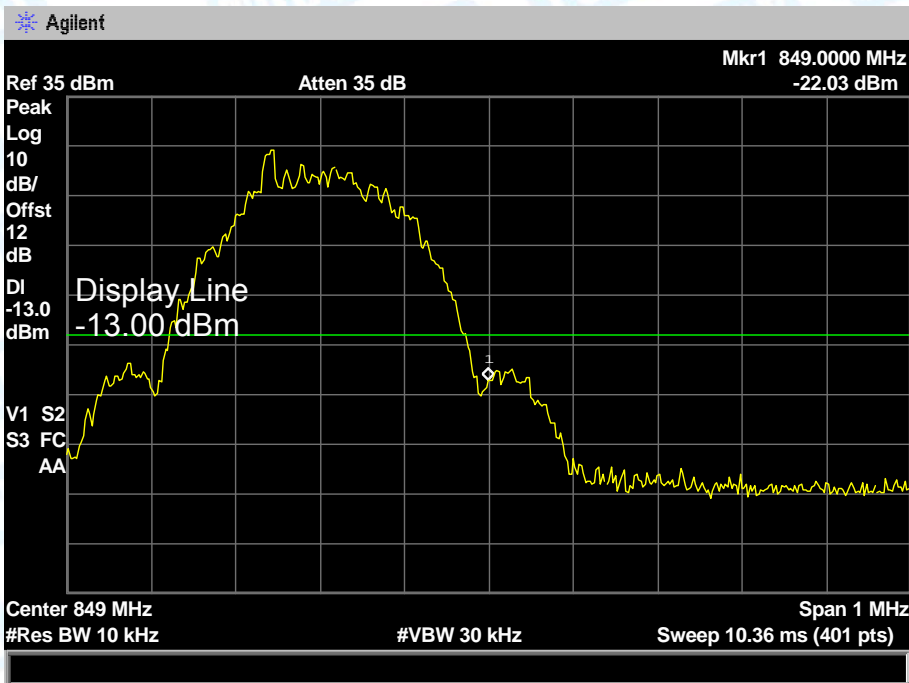

Highest channel

Test Mode:	PCS1900
------------	---------

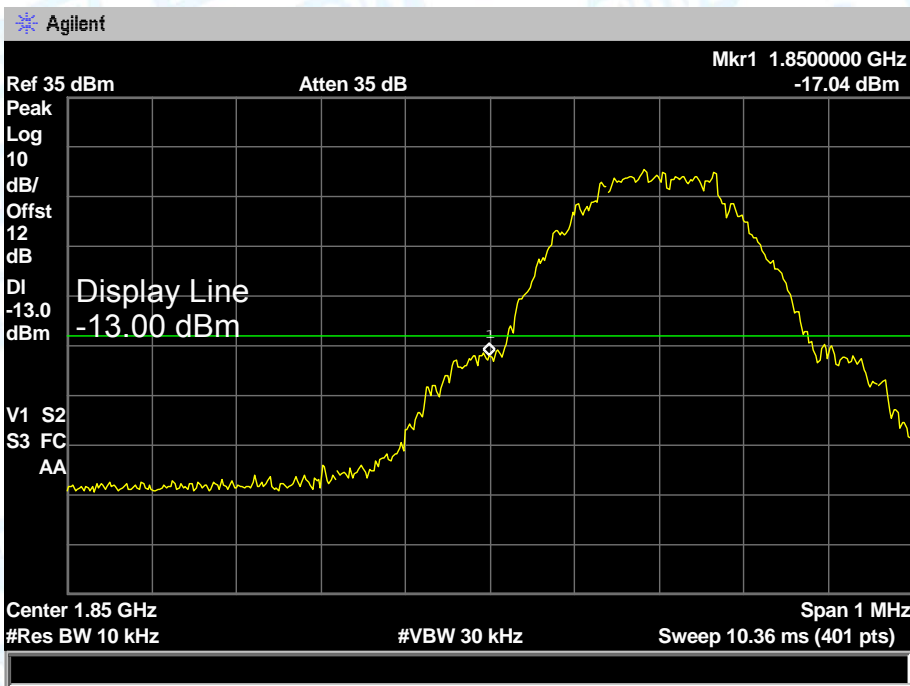

Lowest channel

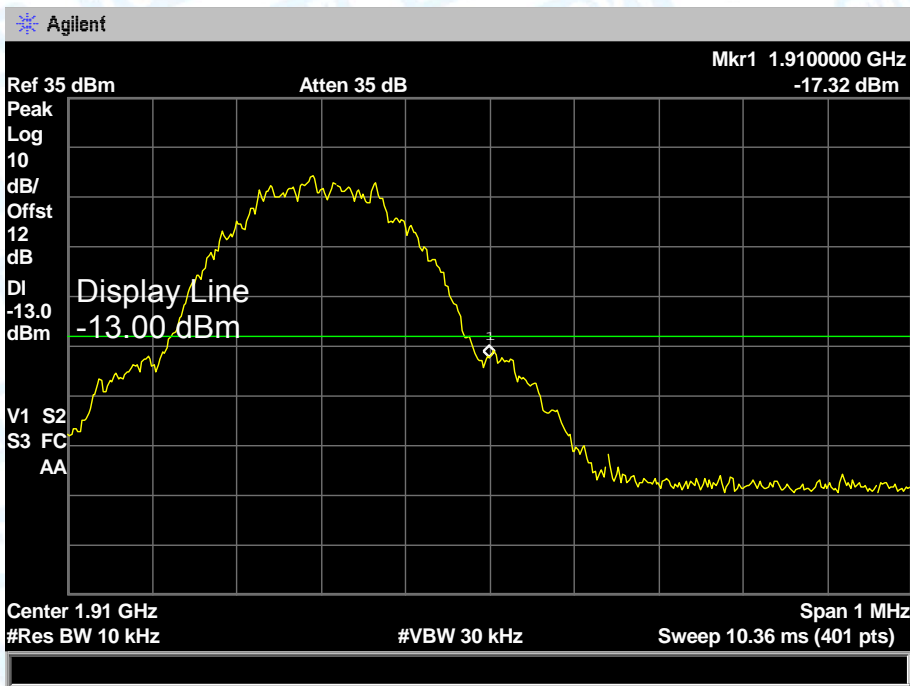

Highest channel

Test Mode: GPRS1900

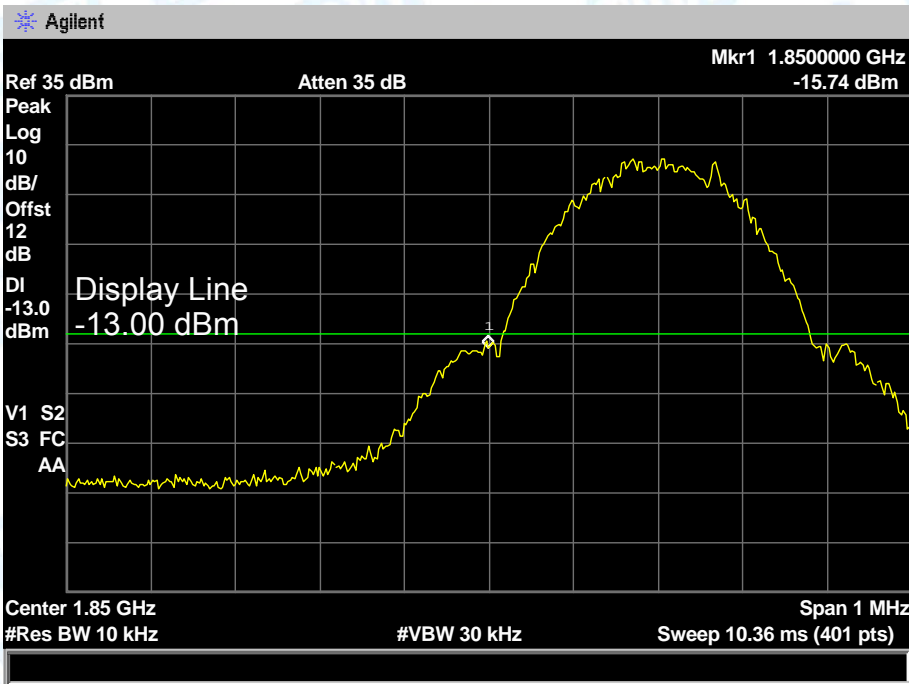

Lowest channel

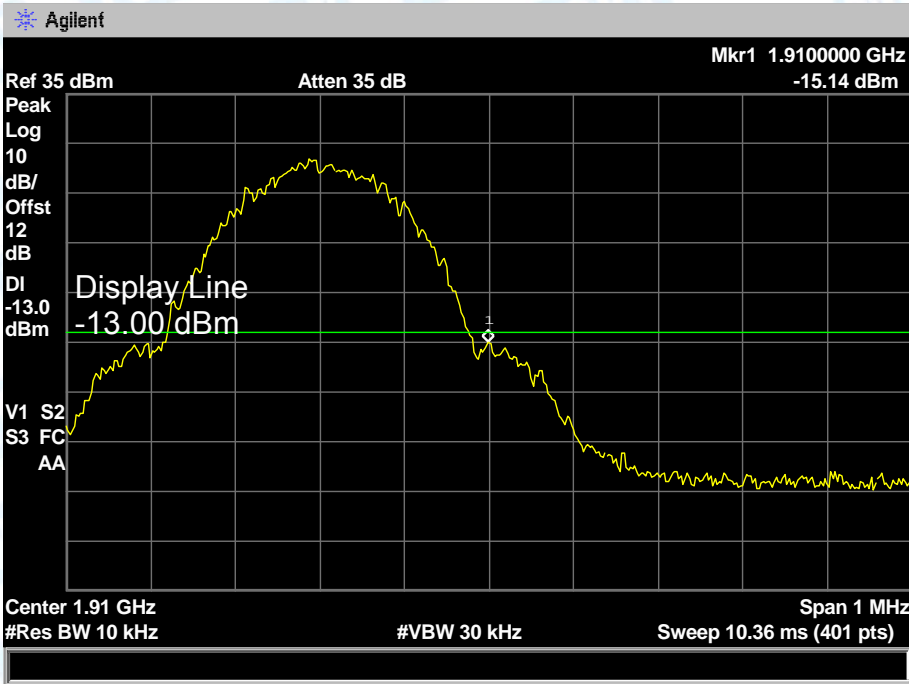

Highest channel

Test Mode: EDGE1900

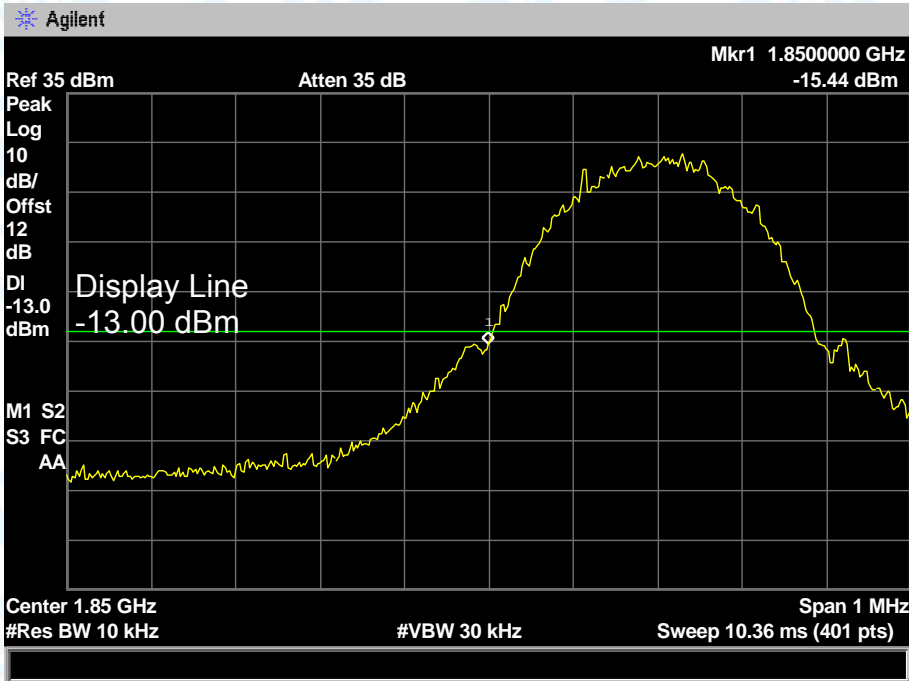

Lowest channel

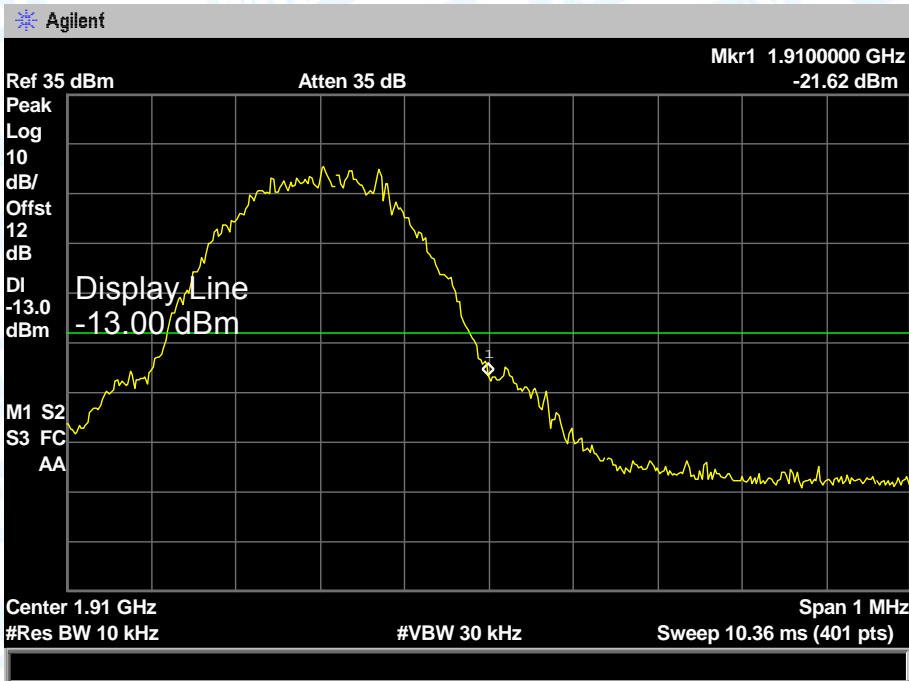

Highest channel

Test Mode: UMTS Band V 12.2k RMC

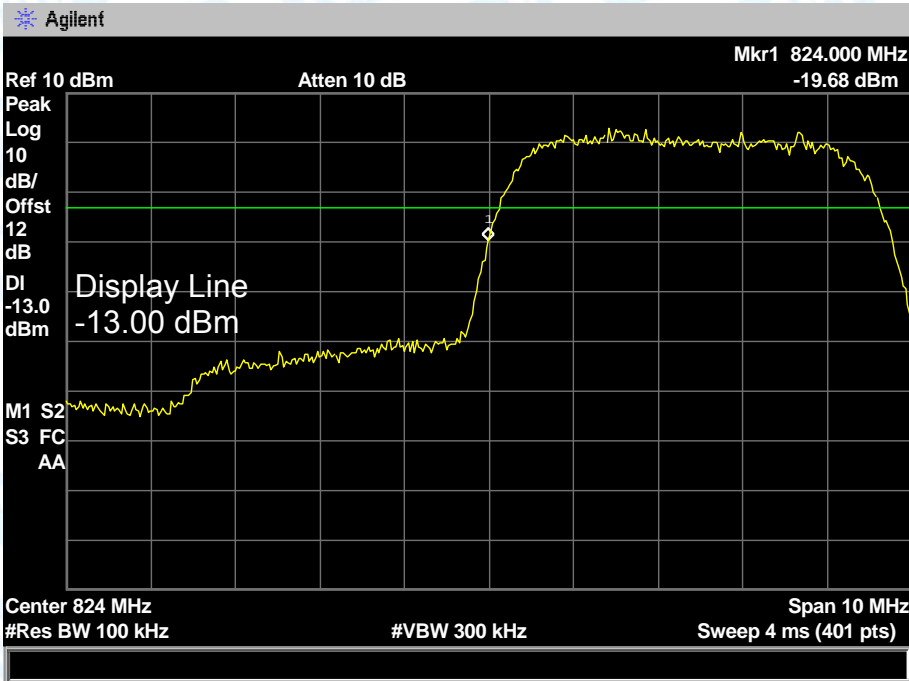

Lowest channel

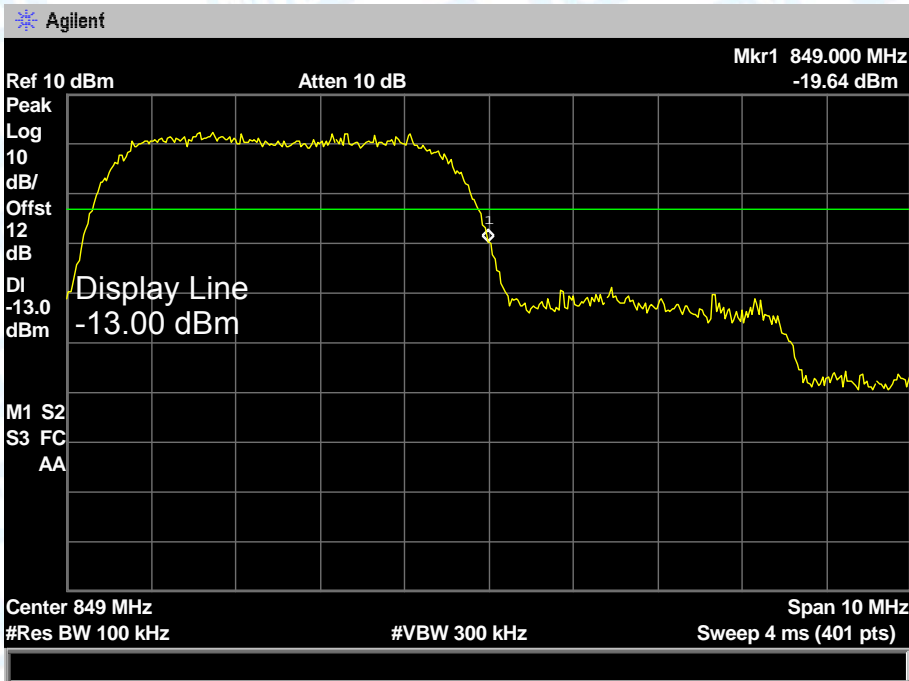

Highest channel

Test Mode: UMTS Band V 12.2k HSDPA

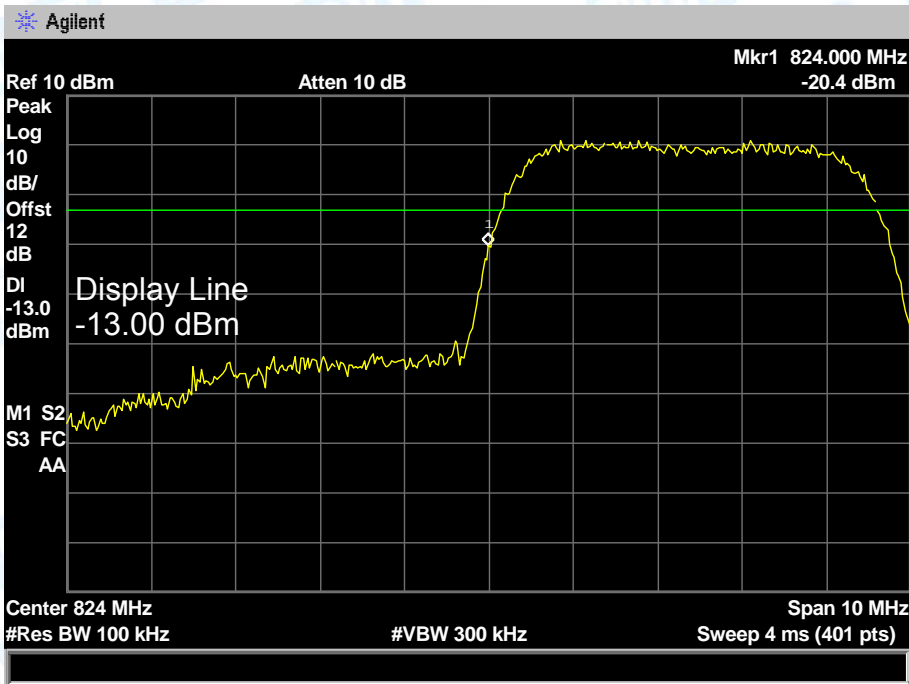

Lowest channel

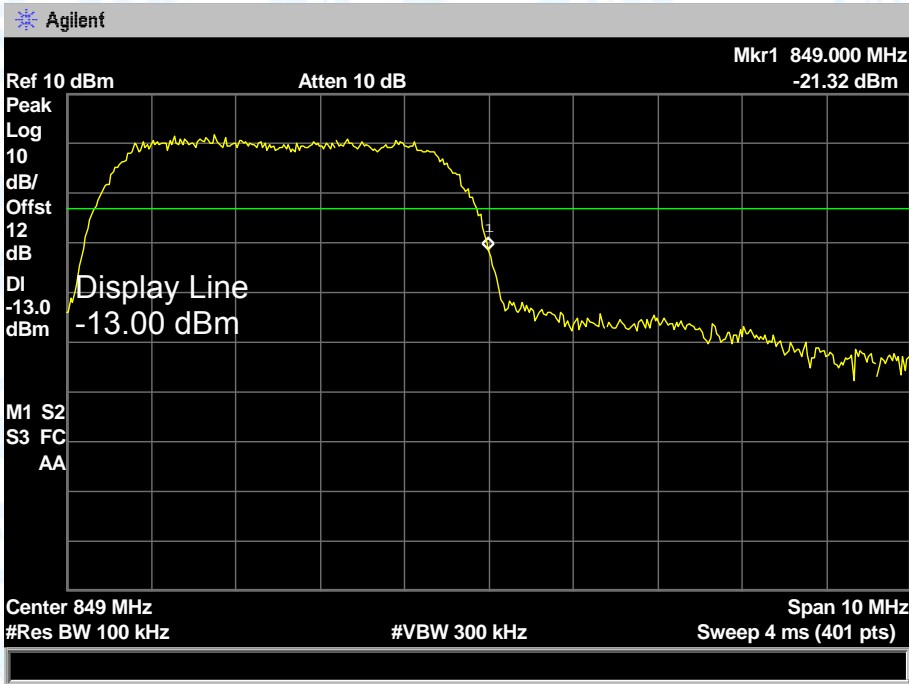

Highest channel

Test Mode: UMTS Band V 12.2k HSUPA

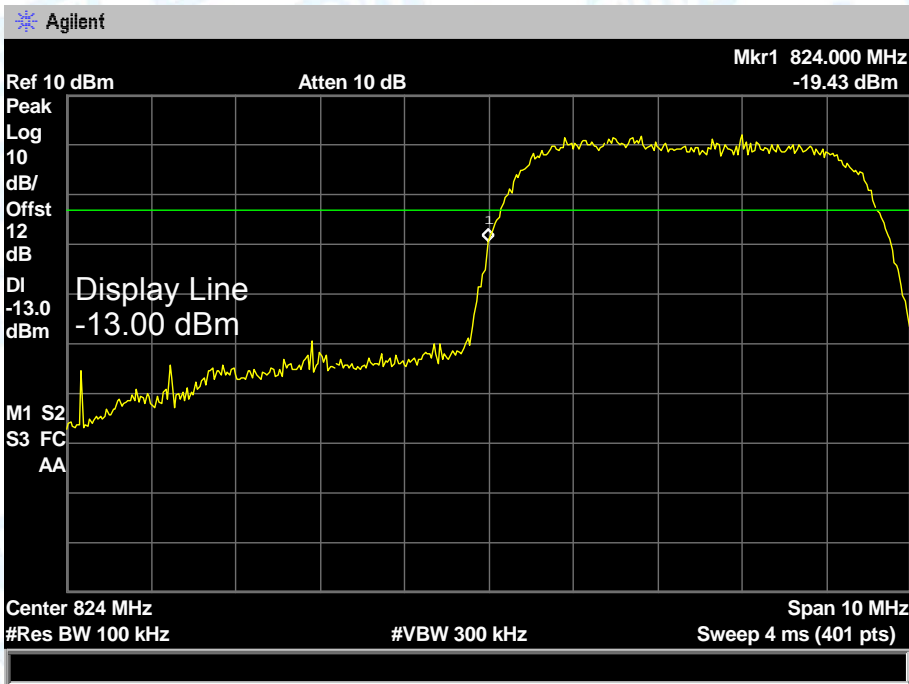

Lowest channel

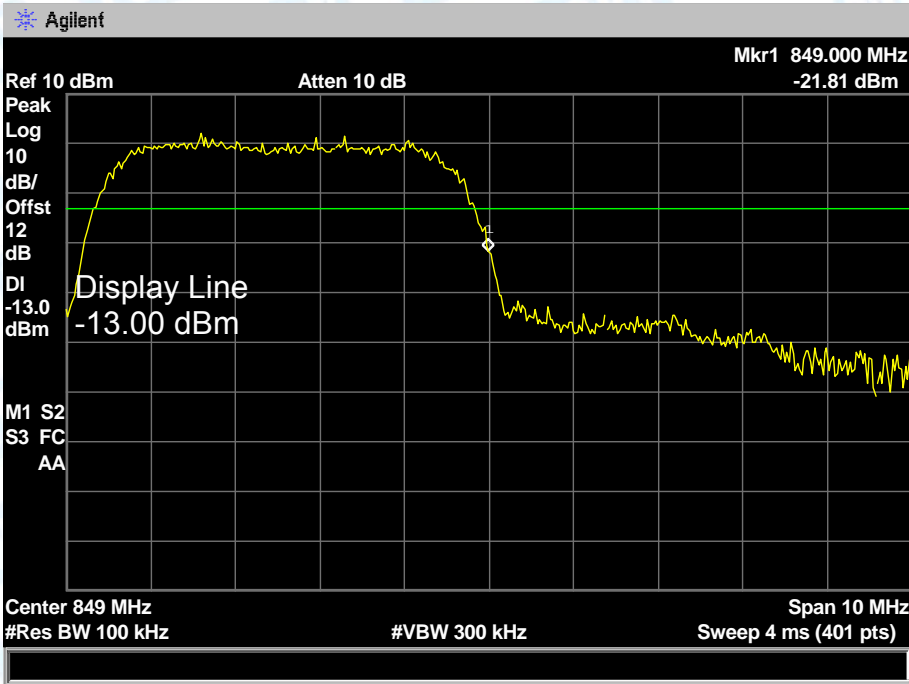

Highest channel

Test Mode: UMTS Band II 12.2k RMC

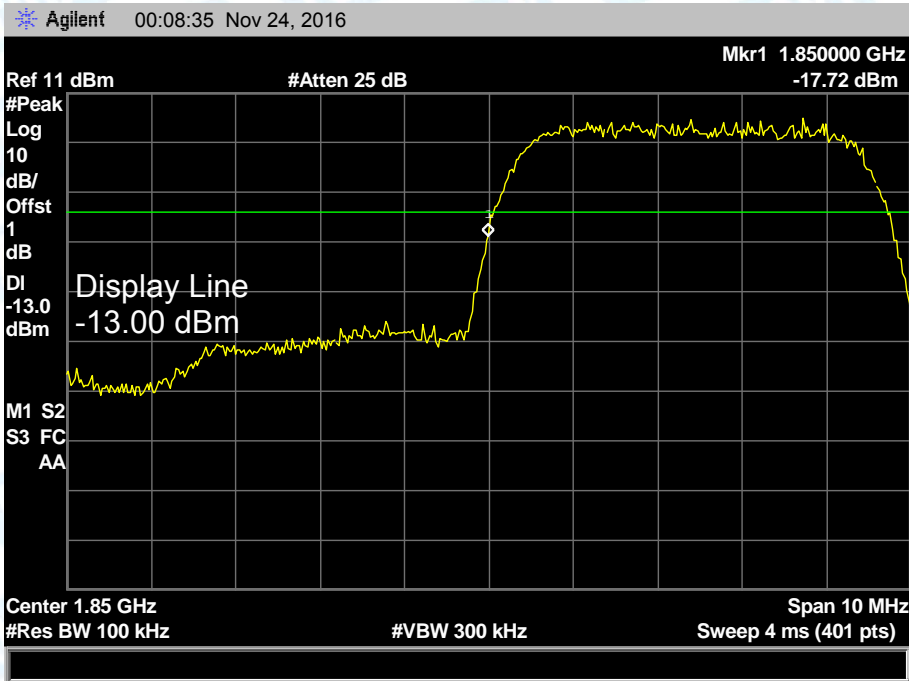

Lowest channel

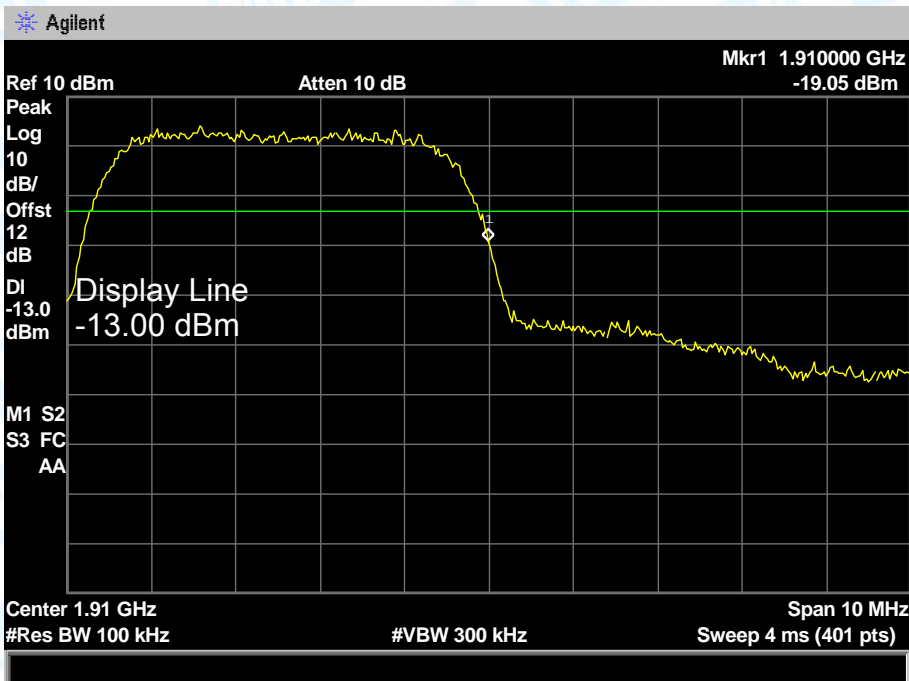

Highest channel

Test Mode: UMTS Band II 12.2k HSDPA

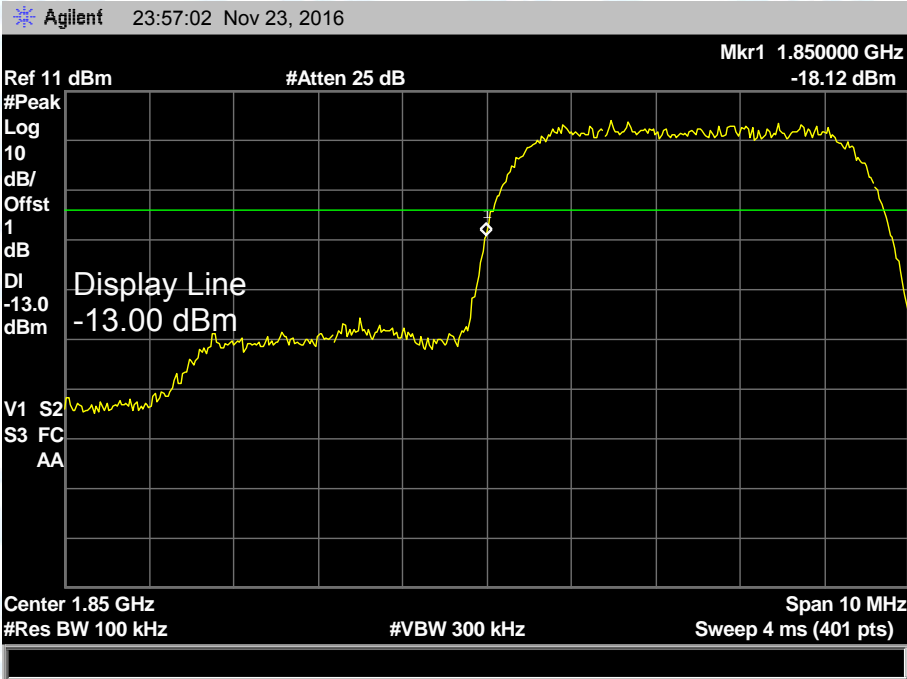

Lowest channel

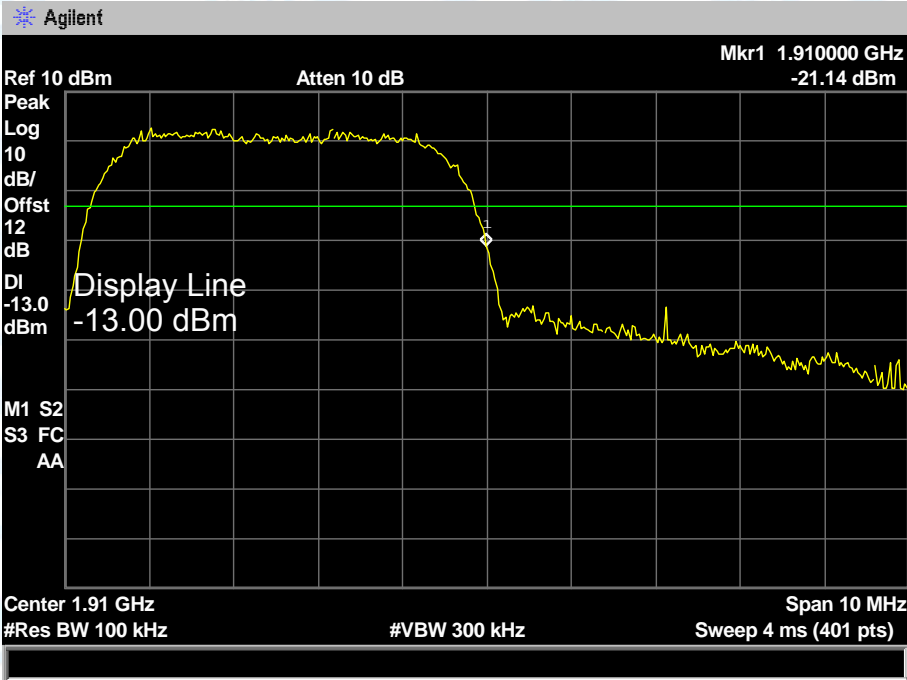

Highest channel

Test Mode: UMTS Band II 12.2k HSUPA

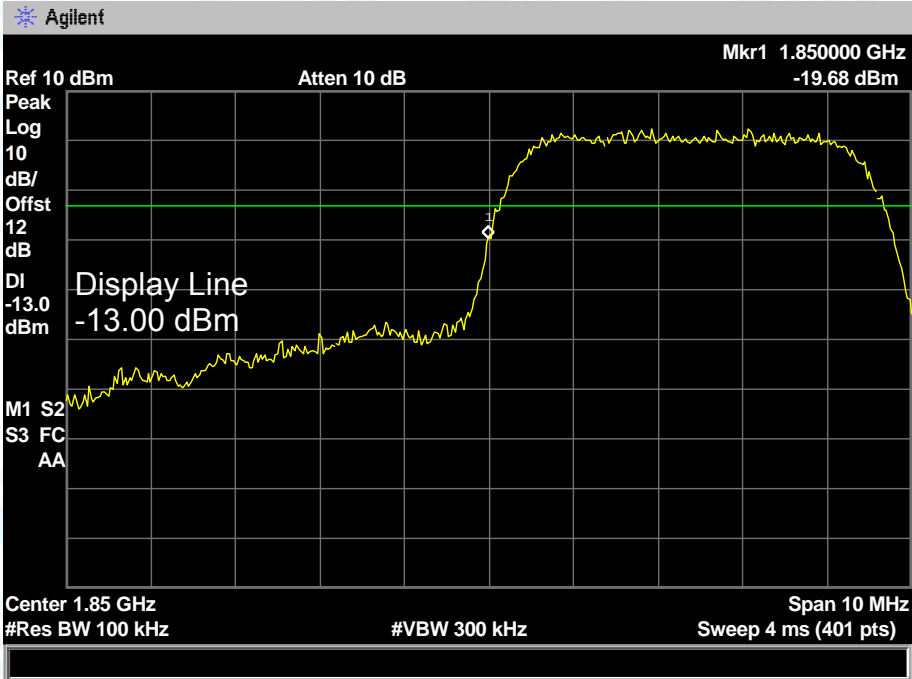

Lowest channel

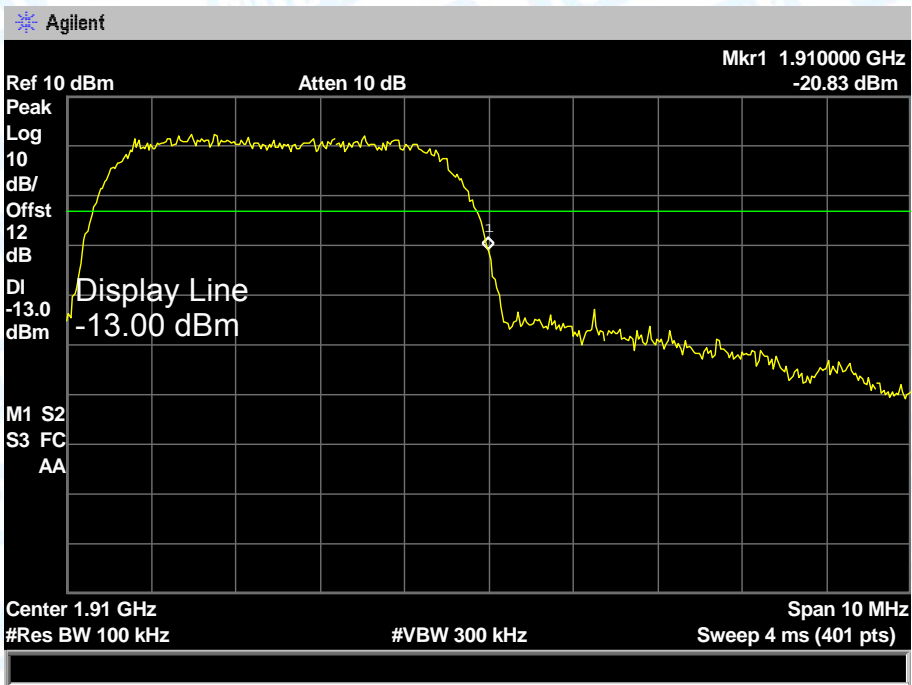

Highest channel

11. Radiated Out Band of Emissions

11.1 Test Standard and Limit

11.1.1 Test Standard

FCC Part 2: 2.1053, 2.1057

FCC Part 22H: 22.917

FCC Part 24E: 24.238

11.1.2 Test Limit

The power of any emission outside of the authorized operating frequency ranges must be attenuated below the transmitting power(P) by a factor of at least $43+10\log(P)$ dB. For all power levels +30 dBm to 0 dBm, this becomes a constant specification limit of -13 dBm.

11.2 Test Setup

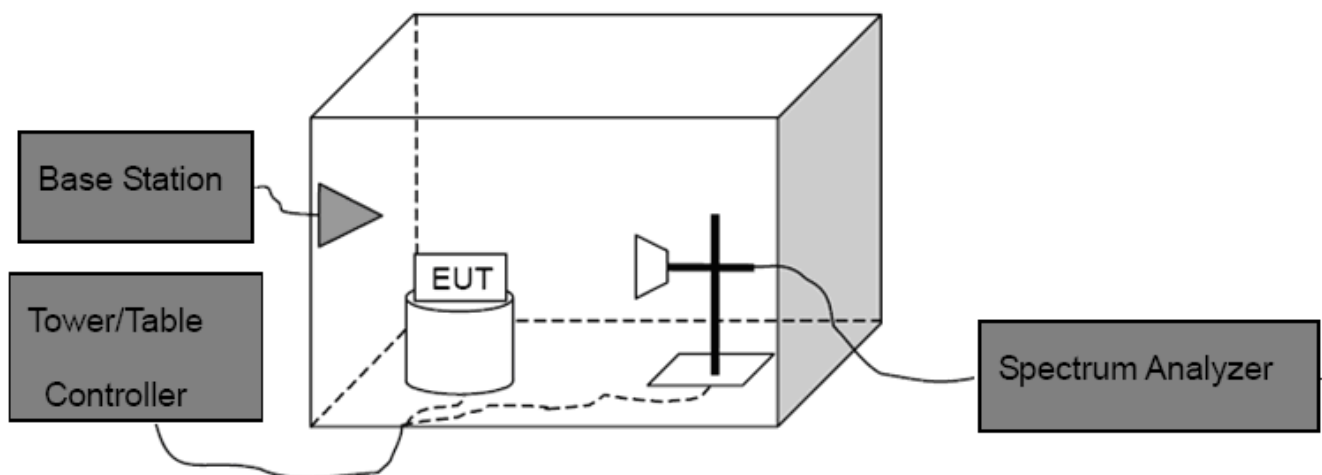

11.3 Test Procedure

- (1) The test system setup as show in the block diagram above.
- (2) The EUT was placed on an non-conductive rotating platform in an anechoic chamber. The radiated spurious emissions from 30MHz to 10th harmonious of fundamental frequency were measured at 3 m with a test antenna and a spectrum analyzer with RBW=1 MHz, VBW=1 MHz, peak detector settings.
- (3) During the measurement, the EUT was enforced in maximum power and linked with a base station. All the spurious emissions at 3m were measured by rotation of the turntable and the test antenna raised and lowered over a range from 1 to 4 meters in both horizontally and vertically polarized orientations.
- (4) When found the maximum level of emissions from the EUT. Remove the EUT and replace it with substitution antenna. A signal generator was connected to the substitution antenna by a non-radiating cable. The absolute levels of the spurious emissions were measured by the substitution.

Spurious emissions in dB=10 log(TX power in Watts/0.001)-the absolute level
Spurious attenuation limit in dB=43+10 log(power out in Watts)

11.4 EUT Operating Condition

The EUT was continuously connected with the Base station and transmitting in the max power during the test.

11.5 Test Data

Please refer the following pages.

Measurement Data (worst case)

Test mode: GSM850							
Channel: Middle		Date of Test: 2017-06-30					
Frequency (MHz)	Spurious Emission					Limit (dBm)	Result
	Polarization (H&V)	Read Level (dBm)	Antenna Correct Factor (dBi)	Cable Loss (dB)	Emission Level (dBm)		
1673.20	Horizontal	-30.23	7.49	3.97	-19.23	-13.00	Pass
2509.80	H	-38.89	7.03	5.05	-21.36		
3346.40	H	-43.88	12.48	5.98	-25.42		
4183.00	H	---	---	---	---		
5019.60	H	---	---	---	---		
5856.20	H	---	---	---	---		
1673.20	Vertical	-35.11	8.02	3.97	-20.67	-13.00	Pass
2509.80	V	-44.56	10.47	5.05	-22.59		
3346.40	V	-47.56	16.92	5.98	-26.54		
4183.00	V	---	---	---	---		
5019.60	V	---	---	---	---		
5856.20	V	---	---	---	---		
Test mode: GPRS850							
Channel: Middle		Date of Test: 2017-06-30					
Frequency (MHz)	Spurious Emission					Limit (dBm)	Result
	Polarization (H&V)	Read Level (dBm)	Antenna Correct Factor (dBi)	Cable Loss (dB)	Emission Level (dBm)		
1673.20	Horizontal	-31.14	7.49	3.97	-20.14	-13.00	Pass
2509.80	H	-39.89	7.03	5.05	-22.36		
3346.40	H	-45.31	12.48	5.98	-26.85		
4183.00	H	---	---	---	---		
5019.60	H	---	---	---	---		
5856.20	H	---	---	---	---		
1673.20	Vertical	-36.11	8.02	3.97	-21.67	-13.00	Pass
2509.80	V	-46.32	10.47	5.05	-24.35		
3346.40	V	-48.63	16.92	5.98	-27.61		
4183.00	V	---	---	---	---		
5019.60	V	---	---	---	---		
5856.20	V	---	---	---	---		
Remark: 1, The testing has been conformed to $10 \times 836.6 \text{MHz} = 8,366 \text{MHz}$. 2, All other emissions more than 30 dB below the limit. 3, Emission Level= Read Level+ Antenna Correct Factor +Cable Loss							

Test mode: EDGE850							
Channel: Middle			Date of Test: 2017-06-30				
Frequency (MHz)	Spurious Emission					Limit (dBm)	Result
	Polarization (H&V)	Read Level (dBm)	Antenna Correct Factor (dBi)	Cable Loss (dB)	Emission Level (dBm)		
1673.20	Horizontal	-33.41	7.49	3.97	-22.41	-13.00	Pass
2509.80	H	-42.20	7.03	5.05	-24.67		
3346.40	H	-46.80	12.48	5.98	-28.34		
4183.00	H	---	---	---	---		
5019.60	H	---	---	---	---		
5856.20	H	---	---	---	---		
1673.20	Vertical	-36.81	8.02	3.97	-22.37	-13.00	Pass
2509.80	V	-47.09	10.47	5.05	-25.12		
3346.40	V	-49.69	16.92	5.98	-28.67		
4183.00	V	---	---	---	---		
5019.60	V	---	---	---	---		
5856.20	V	---	---	---	---		

Remark: 1, The testing has been conformed to $10 \times 836.6\text{MHz} = 8,366\text{MHz}$.
 2, All other emissions more than 30 dB below the limit.
 3, Emission Level= Read Level+ Antenna Correct Factor +Cable Loss

Test mode:		PCS1900						
Channel:		Middle			Date of Test:		2017-06-30	
Frequency (MHz)	Spurious Emission					Limit (dBm)	Result	
	Polarization (H&V)	Read Level (dBm)	Antenna Correct Factor (dBi)	Cable Loss (dB)	Emission Level (dBm)			
3760.00	Horizontal	-40.17	14.70	6.12	-19.35	-13.00	Pass	
5640.00	H	-45.07	13.67	7.86	-23.54			
7520.00	H	-51.49	14.27	9.54	-27.68			
9400.00	H	---	---	---	---			
11280.00	H	---	---	---	---			
13160.00	H	---	---	---	---			
3760.00	Vertical	-41.57	15.81	6.12	-19.64	-13.00	Pass	
5640.00	V	-45.92	13.80	7.86	-24.26			
7520.00	V	-51.39	13.40	9.54	-28.45			
9400.00	V	---	---	---	---			
11280.00	V	---	---	---	---			
13160.00	V	---	---	---	---			

Test mode:		GPRS1900						
Channel:		Middle			Date of Test:		2017-06-30	
Frequency (MHz)	Spurious Emission					Limit (dBm)	Result	
	Polarization (H&V)	Read Level (dBm)	Antenna Correct Factor (dBi)	Cable Loss (dB)	Emission Level (dBm)			
3760.00	Horizontal	-41.05	14.70	6.12	-20.23	-13.00	Pass	
5640.00	H	-46.07	13.67	7.86	-24.54			
7520.00	H	-52.13	14.27	9.54	-28.32			
9400.00	H	---	---	---	---			
11280.00	H	---	---	---	---			
13160.00	H	---	---	---	---			
3760.00	Vertical	-41.91	15.81	6.12	-19.98	-13.00	Pass	
5640.00	V	-46.30	13.80	7.86	-24.64			
7520.00	V	-51.37	13.40	9.54	-28.43			
9400.00	V	---	---	---	---			
11280.00	V	---	---	---	---			
13160.00	V	---	---	---	---			

Remark: 1, The testing has been conformed to $10 \times 1880.0\text{MHz} = 18,800\text{MHz}$.

2, All other emissions more than 30 dB below the limit.

3, Emission Level= Read Level+ Antenna Correct Factor +Cable Loss

Test mode: EDGE1900							
Channel: Middle			Date of Test: 2017-06-30				
Frequency (MHz)	Spurious Emission					Limit (dBm)	Result
	Polarization (H&V)	Read Level (dBm)	Antenna Correct Factor (dBi)	Cable Loss (dB)	Emission Level (dBm)		
3760.00	Horizontal	-42.16	14.70	6.12	-21.34	-13.00	Pass
5640.00	H	-47.76	13.67	7.86	-26.23		
7520.00	H	-53.36	14.27	9.54	-29.55		
9400.00	H	---	---	---	---		
11280.00	H	---	---	---	---		
13160.00	H	---	---	---	---		
3760.00	Vertical	-43.40	15.81	6.12	-21.47	-13.00	Pass
5640.00	V	-48.51	13.80	7.86	-26.85		
7520.00	V	-52.61	13.40	9.54	-29.67		
9400.00	V	---	---	---	---		
11280.00	V	---	---	---	---		
13160.00	V	---	---	---	---		

Remark: 1, The testing has been conformed to $10 \times 1880.0\text{MHz} = 18,800\text{MHz}$.
 2, All other emissions more than 30 dB below the limit.
 3, Emission Level= Read Level+ Antenna Correct Factor +Cable Loss

Test mode: UMTS Band V 12.2k RMC							
Channel: Middle		Date of Test: 2017-06-30					
Frequency (MHz)	Spurious Emission					Limit (dBm)	Result
	Polarization (H&V)	Read Level (dBm)	Antenna Correct Factor (dBi)	Cable Loss (dB)	Emission Level (dBm)		
1673.20	Horizontal	-34.65	7.49	3.97	-23.65	-13.00	Pass
2509.80	H	-43.15	7.03	5.05	-25.62		
3346.40	H	-48.11	12.48	5.98	-29.65		
4183.00	H	---	---	---	---		
5019.60	H	---	---	---	---		
5856.20	H	---	---	---	---		
1673.20	Vertical	-37.91	8.02	3.97	-23.47	-13.00	Pass
2509.80	V	-47.84	10.47	5.05	-25.87		
3346.40	V	-51.14	16.92	5.98	-30.12		
4183.00	V	---	---	---	---		
5019.60	V	---	---	---	---		
5856.20	V	---	---	---	---		
Test mode: UMTS Band V HSDPA							
Channel: Middle		Date of Test: 2017-06-30					
Frequency (MHz)	Spurious Emission					Limit (dBm)	Result
	Polarization (H&V)	Read Level (dBm)	Antenna Correct Factor (dBi)	Cable Loss (dB)	Emission Level (dBm)		
1673.20	Horizontal	-34.87	7.49	3.97	-23.87	-13.00	Pass
2509.80	H	-42.97	7.03	5.05	-25.44		
3346.40	H	-47.89	12.48	5.98	-29.43		
4183.00	H	---	---	---	---		
5019.60	H	---	---	---	---		
5856.20	H	---	---	---	---		
1673.20	Vertical	-37.42	8.02	3.97	-22.98	-13.00	Pass
2509.80	V	-46.66	10.47	5.05	-24.69		
3346.40	V	-49.69	16.92	5.98	-28.67		
4183.00	V	---	---	---	---		
5019.60	V	---	---	---	---		
5856.20	V	---	---	---	---		
Remark: 1, The testing has been conformed to $10 \times 836.6 \text{MHz} = 8,366 \text{MHz}$. 2, All other emissions more than 30 dB below the limit. 3, Emission Level= Read Level+ Antenna Correct Factor +Cable Loss							

Test mode: UMTS Band V HSUPA							
Channel: Middle			Date of Test: 2017-06-30				
Frequency (MHz)	Spurious Emission					Limit (dBm)	Result
	Polarization (H&V)	Read Level (dBm)	Antenna Correct Factor (dBi)	Cable Loss (dB)	Emission Level (dBm)		
1673.20	Horizontal	-34.68	7.49	3.97	-23.68	-13.00	Pass
2509.80	H	-43.28	7.03	5.05	-25.75		
3346.40	H	-47.99	12.48	5.98	-29.53		
4183.00	H	---	---	---	---		
5019.60	H	---	---	---	---		
5856.20	H	---	---	---	---		
1673.20	Vertical	-38.25	8.02	3.97	-23.81	-13.00	Pass
2509.80	V	-47.68	10.47	5.05	-25.71		
3346.40	V	-50.40	16.92	5.98	-29.38		
4183.00	V	---	---	---	---		
5019.60	V	---	---	---	---		
5856.20	V	---	---	---	---		

Remark: 1, The testing has been conformed to $10 \times 836.6\text{MHz} = 8,366\text{MHz}$.
 2, All other emissions more than 30 dB below the limit.
 3, Emission Level= Read Level+ Antenna Correct Factor +Cable Loss

Test mode: UMTS Band II 12.2k RMC							
Channel: Middle		Date of Test: 2017-06-30					
Frequency (MHz)	Spurious Emission					Limit (dBm)	Result
	Polarization (H&V)	Read Level (dBm)	Antenna Correct Factor (dBi)	Cable Loss (dB)	Emission Level (dBm)		
3760.00	Horizontal	-41.47	14.70	6.12	-20.65	-13.00	Pass
5640.00	H	-45.27	13.67	7.86	-23.74		
7520.00	H	-50.67	14.27	9.54	-26.86		
9400.00	H	---	---	---	---		
11280.00	H	---	---	---	---		
13160.00	H	---	---	---	---		
3760.00	Vertical	-42.26	15.81	6.12	-20.33	-13.00	Pass
5640.00	V	-45.87	13.80	7.86	-24.21		
7520.00	V	-49.97	13.40	9.54	-27.03		
9400.00	V	---	---	---	---		
11280.00	V	---	---	---	---		
13160.00	V	---	---	---	---		

Test mode: UMTS Band II HSDPA							
Channel: Middle		Date of Test: 2017-06-30					
Frequency (MHz)	Spurious Emission					Limit (dBm)	Result
	Polarization (H&V)	Read Level (dBm)	Antenna Correct Factor (dBi)	Cable Loss (dB)	Emission Level (dBm)		
3760.00	Horizontal	-41.50	14.70	6.12	-20.68	-13.00	Pass
5640.00	H	-45.39	13.67	7.86	-23.86		
7520.00	H	-51.04	14.27	9.54	-27.23		
9400.00	H	---	---	---	---		
11280.00	H	---	---	---	---		
13160.00	H	---	---	---	---		
3760.00	Vertical	-42.30	15.81	6.12	-20.37	-13.00	Pass
5640.00	V	-45.83	13.80	7.86	-24.17		
7520.00	V	-50.52	13.40	9.54	-27.58		
9400.00	V	---	---	---	---		
11280.00	V	---	---	---	---		
13160.00	V	---	---	---	---		

Remark: 1, The testing has been conformed to $10 \times 1880.0\text{MHz} = 18,800\text{MHz}$.

2, All other emissions more than 30 dB below the limit.

3, Emission Level= Read Level+ Antenna Correct Factor +Cable Loss

Test mode: UMTS Band II HSUPA							
Channel: Middle		Date of Test: 2017-06-30					
Frequency (MHz)	Spurious Emission					Limit (dBm)	Result
	Polarization (H&V)	Read Level (dBm)	Antenna Correct Factor (dBi)	Cable Loss (dB)	Emission Level (dBm)		
3760.00	Horizontal	-40.50	14.70	6.12	-19.68	-13.00	Pass
5640.00	H	-44.27	13.67	7.86	-22.74		
7520.00	H	-50.37	14.27	9.54	-26.56		
9400.00	H	---	---	---	---		
11280.00	H	---	---	---	---		
13160.00	H	---	---	---	---		
3760.00	Vertical	-42.24	15.81	6.12	-20.31	-13.00	Pass
5640.00	V	-45.18	13.80	7.86	-23.52		
7520.00	V	-49.42	13.40	9.54	-26.48		
9400.00	V	---	---	---	---		
11280.00	V	---	---	---	---		
13160.00	V	---	---	---	---		

Remark: 1, The testing has been conformed to $10 \times 1880.0\text{MHz} = 18,800\text{MHz}$.
 2, All other emissions more than 30 dB below the limit.
 3, Emission Level= Read Level+ Antenna Correct Factor +Cable Loss

-----End of Report-----