

# FCC Radio Test Report

## FCC ID: 2AJ9Z-4GX9

### Original Grant

**Report No.** : TB-FCC150439  
**Applicant** : EMATIC LIMITED  
**Equipment Under Test (EUT)**  
**EUT Name** : ROCK X9+  
**Model No.** : ROCK X9+  
**Series No.** : N/A  
**Brand Name** : EXTREM  
**Receipt Date** : 2016-11-04  
**Test Date** : 2016-11-05 to 2016-12-09  
**Issue Date** : 2016-12-10  
**Standards** : FCC Part 2  
FCC Part 22 Subpart H, FCC Part 24 Subpart E, 2015  
ANSI/TIAC63.26: 2015  
**Conclusions** : **PASS**  
In the configuration tested, the EUT complied with the standards specified above,  
The EUT technically complies with the FCC requirements

**Test/Witness Engineer** :

*IWAN SU*

**Approved & Authorized** :

*Ray Lai*



This report details the results of the testing carried out on one sample. The results contained in this test report do not relate to other samples of the same product. The manufacturer should ensure that all products in series production are in conformity with the product sample detailed in the report.

---

---

## Contents

<b>CONTENTS</b> .....	<b>2</b>
<b>1. GENERAL INFORMATION ABOUT EUT</b> .....	<b>4</b>
1.1 Client Information.....	4
1.2 General Description of EUT (Equipment Under Test) .....	4
1.3 Block Diagram Showing the Configuration of System Tested.....	5
1.4 Description of Support Units .....	5
1.5 Description of Test Mode.....	5
1.6 Measurement Uncertainty .....	7
1.7 Test Facility.....	7
<b>2. TEST SUMMARY</b> .....	<b>8</b>
<b>3. TEST EQUIPMENT</b> .....	<b>9</b>
<b>4. FREQUENCY STABILITY</b> .....	<b>10</b>
4.1 Test Standard and Requirement .....	10
4.2 Test Setup.....	10
4.3 Test Procedure.....	11
4.4 EUT Operating Condition .....	11
<b>5. CONDUCTED RF OUTPUT POWER</b> .....	<b>15</b>
5.1 Test Standard and Limit.....	15
5.2 Test Setup.....	15
5.3 Test Procedure.....	15
5.4 EUT Operating Condition .....	15
5.5 EUT Operating Condition .....	15
<b>6. PEAK-AVERAGE RATIO</b> .....	<b>20</b>
6.1 Test Standard and Limit.....	20
6.2 Test Setup.....	20
6.3 Test Procedure.....	20
6.4 EUT Operating Condition .....	20
6.5 Test Data.....	21
<b>7. RADIATED OUTPUT POWER</b> .....	<b>25</b>
7.1 Test Standard and Limit.....	25
7.2 Test Setup.....	25
7.3 Test Procedure.....	26
7.4 EUT Operating Condition .....	26
7.5 Test Data.....	27
<b>8. OCCUPIED BANDWIDTH</b> .....	<b>30</b>
8.1 Test Standard and Limit.....	30
8.2 Test Setup.....	30

8.3 Test Procedure.....	30
8.4 EUT Operating Condition .....	31
8.5 Test Data.....	31
<b>9. CONDUCTED OUT OF BAND EMISSIONS.....</b>	<b>58</b>
9.1 Test Standard and Limit.....	58
9.2 Test Setup.....	58
9.3 Test Procedure.....	58
9.4 EUT Operating Condition .....	58
9.5 Test Data.....	59
Please refer following plots:.....	59
<b>10. BAND EDGE TEST .....</b>	<b>83</b>
10.1 Test Standard and Limit .....	83
10.2 Test Setup.....	83
10.3 Test Procedure.....	83
10.4 EUT Operating Condition .....	83
10.5 Test Data.....	84
<b>11. RADIATED OUT BAND OF EMISSIONS.....</b>	<b>96</b>
11.1 Test Standard and Limit .....	96
11.2 Test Setup.....	96
11.3 Test Procedure.....	96
11.4 EUT Operating Condition .....	97
11.5 Test Data.....	97

# 1. General Information about EUT

## 1.1 Client Information

**Applicant** : EMATIC LIMITED  
**Address** : Unit 17, 9/F Tower A, New Mandarin Plaza NO, 14 Science Museum Rd, TST, Hong Kong, China  
**Manufacturer** : EMATIC LIMITED  
**Address** : Unit 17, 9/F Tower A, New Mandarin Plaza NO, 14 Science Museum Rd, TST, Hong Kong, China

## 1.2 General Description of EUT (Equipment Under Test)

<b>EUT Name</b>	:	ROCK X9+
<b>Models No.</b>	:	ROCK X9+
<b>Model Difference</b>	:	N/A
<b>Product Description</b>	:	Frequency Bands: GSM850; PCS1900; UMTS FDD Band II; UMTS FDD Band V
		GSM 850 Power : Cond:32.74 dBm ERP:30.98 dBm
		PCS 1900 Power : Cond:31.56 dBm EIRP:30.24 dBm
		UMTS Band II Power: Cond:22.94 dBm EIRP:20.68 dBm
		UMTS Band V Power: Cond:20.85 dBm ERP:18.86 dBm
		Antenna Gain: GSM 850: -0.25 dBi PCS 1900: 2.79 dBi WCDMA Band V: -0.25 dBi WCDMA Band II: 2.79 dBi
	Modulation Type: GSM/GPRS:GMSK EDGE: 8PSK UMTS:QPSK	
<b>FCC Operating Frequency</b>	:	GSM 850: 824.20MHz-848.80MHz PCS1900: 1850.20MHz-1909.80MHz UMTS Band II: 1852.40MHz-1907.60MHz UMTS Band V:826.40MHz-846.60MHz
<b>Emission Designator</b>	:	GSM 850: 247KGXW, PCS 1900: 250KGXW GPRS 850: 250KG7W, GPRS 1900: 250KG7W EGPRS 850: 254KG7W, EGPRS 1900: 252KG7W UMTS Band V: 4M23F9W, UMTS Band II: 4M24F9W
<b>Power Supply</b>	:	DC power supplied by AC/DC Adapter. DC Voltage supplied from Li-ion battery.

<b>Power Rating</b>	:	Input: AC 100~240V 50/60Hz, 0.3A. Output: 5V/2000mA. DC 3.7V from 4200mA Li-ion battery.
<b>Connecting I/O Port(S)</b>	:	Please refer to the User's Manual

**Note:**

- (1) For a more detailed features description, please refer to the manufacturer's specifications or the User's Manual.
- (2) This test report only product for PCE-PCS Licensed Transmitter Held to ear..

### 1.3 Block Diagram Showing the Configuration of System Tested

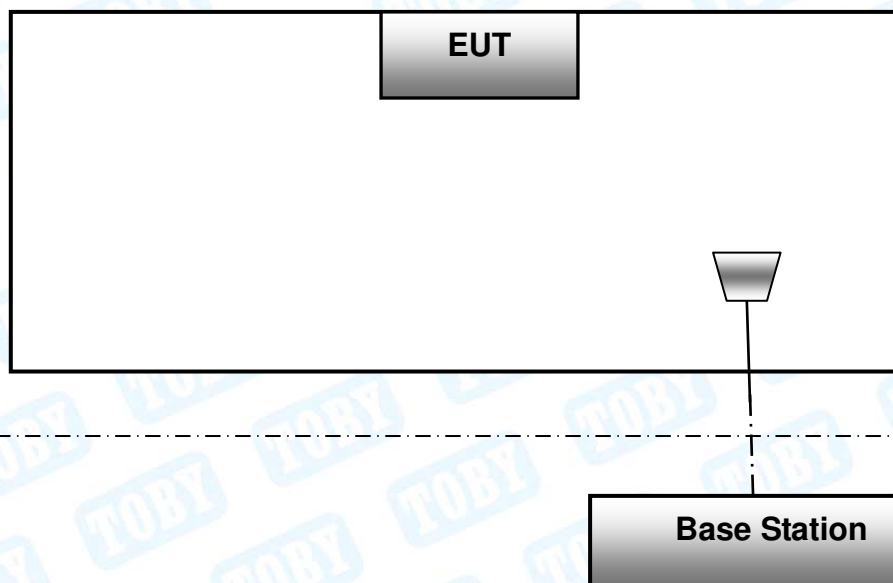

The above block diagram of setup is the normal mode. And more detail please refer to the test setup of each test item of bellow.

### 1.4 Description of Support Units

The EUT has been tested as an independent unit.

### 1.5 Description of Test Mode

To investigate the maximum EMI emission characteristics generates from EUT, the test system was pre-scanning tested base on the consideration of following EUT operation mode or test configuration mode which possible have effect on EMI emission level. Each of these EUT operation mode(s) or test configuration mode(s) mentioned follow was evaluated respectively.

During all testing, EUT is link mode with base station at maximum power level. The spurious emission measurements were carried out in semi-anechoic chamber with 3-meter test range. Frequency range investigated for radiated emission as below:

1. 9kHz~10GHz for GSM850 and UMTS Band V.

## 2. 9kHz~20GHz for PCS1900 and UMTS Band II.

Test Channel		
Mode	Channel	Frequency(MHz)
GSM 850	128	824.20
	190	836.60
	251	848.80
PCS 1900	512	1850.20
	661	1880.00
	810	1909.80
UMTS Band V	4132	826.40
	4183	836.60
	4233	846.60
UMTS Band II	9262	1852.40
	9400	1880.00
	9538	1907.60
Pre-scanning test Mode		Description
GSM 850		highest , middle, lowest channels
GPRS 850		highest , middle, lowest channels
GSM 1900		highest , middle, lowest channels
GPRS 1900		highest , middle, lowest channels
RMC UMTS Band V		highest , middle, lowest channels
HSDPA UMTS Band V		highest , middle, lowest channels
HSUPA UMTS Band V		highest , middle, lowest channels
RMC UMTS Band II		highest , middle, lowest channels
HSDPA UMTS Band II		highest , middle, lowest channels
HSUPA UMTS Band II		highest , middle, lowest channels
Final test Mode		Description
GSM 850		highest , middle, lowest channels
GSM 1900		highest , middle, lowest channels
RMC UMTS 850		highest , middle, lowest channels
RMC UMTS Band II		highest , middle, lowest channels

**Note:**

- (1) The measurements are performed at the highest, middle, lowest available channels.
- (2) During the testing procedure, the EUT is in link mode with base station emulator at

maximum power level in each test mode.

- (3) The EUT has GSM, GPRS, EDGE functions, and after pre-testing, GSM function is the worst case for all the emission tests.
- (4) The EUT has RMC, HSDPA, HSUPA functions in UMTS band II and UMTS band V, and after pre-testing, RMC mode is the worst case for all the emission tests.
- (5) The EUT is considered a portable unit; it was pre-tested on the positioned of each 3 axis, X-plane, Y-plane and Z-plane. The worst case was found positioned on Z-plane as the normal use. Therefore only the test data of this Z-plane was used for radiated emission measurement test.

## 1.6 Measurement Uncertainty

Test Item	Parameters	Expanded Uncertainty ( $U_{Lab}$ )
Conducted Emission	Level Accuracy: 9kHz~150kHz	$\pm 3.42$ dB
	150kHz to 30MHz	$\pm 3.42$ dB
Radiated Emission	Level Accuracy: 9kHz to 30 MHz	$\pm 4.60$ dB
Radiated Emission	Level Accuracy: 30MHz to 1000 MHz	$\pm 4.40$ dB
Radiated Emission	Level Accuracy: Above 1000MHz	$\pm 4.20$ dB

## 1.7 Test Facility

The testing was performed by the Shenzhen Toby Technology Co., Ltd., in their facilities located at: 1A/F., Bldg.6, Yusheng Industrial Zone, The National Road No.107 Xixiang Section 467, Xixiang, Bao'an, Shenzhen, Guangdong, China.

At the time of testing, the following bodies accredited the Laboratory:

### **CNAS (L5813)**

The Laboratory has been accredited by CNAS to ISO/IEC 17025: 2005 General Requirements for the Competence of Testing and Calibration Laboratories for the competence in the field of testing. And the Registration No.: CNAS L5813.

### **FCC List No.: (811562)**

The Laboratory is listed in the United States of American Federal Communications Commission (FCC), and the registration number is 811562.

### **IC Registration No.: (11950A-1)**

The Laboratory has been registered by Certification and Engineering Bureau of Industry Canada for radio equipment testing. The site registration: Site# 11950A-1.

## 2. Test Summary

Test Standards and Test Results			
Standard	Document Title		
FCC Part 2 (10-1-05 Edition)	Frequency Allocations and Radio Treaty Matters; General Rules and Regulations		
FCC Part 22 (10-1-05 Edition)	Public Mobile Services		
FCC Part 24 (10-1-05 Edition)	Personal Communications Services		
Standard Section	Test Item	Judgment	Remark
2.1046	Conducted RF Output Power	PASS	N/A
24.232(d)	Peak-Average Ratio	PASS	N/A
2.1049; 22.917; 24.238	99% & -26 dB Occupied Bandwidth	PASS	N/A
2.1055; 22.355; 24.235	Frequency Stability	PASS	N/A
2.1051; 2.1057; 22.917; 24.238	Conducted Out of Band Emissions	PASS	N/A
2.1051; 2.1057; 22.917; 24.238	Band Edge	PASS	N/A
22.913; 24.238	Transmitter Radiated Power (EIRP/ERP)	PASS	N/A
2.1053; 2.1057; 22.917; 24.238	Radiated Out of Band Emissions	PASS	N/A
<b>Note:</b> N/A is an abbreviation for Not Applicable.			



### 3. Test Equipment

AC Main Conducted Emission					
Description	Manufacturer	Model No.	Serial No.	Cal. Date	Cal. Due Date
EMI Test Receiver	ROHDE& SCHWARZ	ESCI	100321	Jul. 22, 2016	Jul. 21, 2017
50ΩCoaxial Switch	Anritsu	MP59B	X10321	Jul. 22, 2016	Jul. 21, 2017
L.I.S.N	Rohde & Schwarz	ENV216	101131	Jul. 22, 2016	Jul. 21, 2017
L.I.S.N	SCHWARZBECK	NNBL 8226-2	8226-2/164	Jul. 22, 2016	Jul. 21, 2017
Radiation Spurious Emission					
Description	Manufacturer	Model No.	Serial No.	Cal. Date	Cal. Due Date
Spectrum Analyzer	Agilent	E4407B	MY45106456	Jul. 22, 2016	Jul. 21, 2017
EMI Test Receiver	Rohde & Schwarz	ESCI	100010/007	Jul. 22, 2016	Jul. 21, 2017
Bilog Antenna	ETS-LINDGREN	3142E	00117537	Mar. 20, 2016	Mar. 19, 2017
Bilog Antenna	ETS-LINDGREN	3142E	00117542	Mar. 20, 2016	Mar. 19, 2017
Horn Antenna	ETS-LINDGREN	3117	00143207	Mar. 19, 2016	Mar. 18, 2017
Horn Antenna	ETS-LINDGREN	3117	00143209	Mar. 19, 2016	Mar. 18, 2017
Pre-amplifier	Sonoma	310N	185903	Mar. 20, 2016	Mar. 19, 2017
Pre-amplifier	HP	8449B	3008A00849	Mar. 26, 2016	Mar. 25, 2017
Cable	HUBER+SUHNER	100	SUCOFLEX	Mar. 26, 2016	Mar. 25, 2017
Signal Generator	Rohde & Schwarz	SML03	IKW682-054	Mar. 26, 2016	Mar. 25, 2017
Positioning Controller	ETS-LINDGREN	2090	N/A	N/A	N/A
Universal Radio Communication Tester	Rohde&Schwarz	CMU200	103903	Jun.23, 2016	Jun.22, 2017
Antenna Conducted Emission					
Description	Manufacturer	Model No.	Serial No.	Cal. Date	Cal. Due Date
Spectrum Analyzer	Agilent	E4407B	MY45106456	Jul. 22, 2016	Jul. 21, 2017
Spectrum Analyzer	Rohde & Schwarz	ESCI	100321	Jul. 22, 2016	Jul. 21, 2017
Universal Radio Communication Tester	Rohde&Schwarz	CMU200	103903	Jun.23, 2016	Jun.22, 2017

## 4. Frequency Stability

### 4.1 Test Standard and Requirement

#### 4.1.1 Test Standard

FCC Part 2.1055

FCC Part 22.355

FCC Part 24.235

#### 4.1.2 Requirement

According to FCC section 22.355 and FCC section 24.235, the frequency stability shall be sufficient to ensure that the fundamental emission stays within the authorized frequency block. According to FCC section 2.1055, the test conditions are:

(1) Temperature:

The temperature is varied from  $-30^{\circ}\text{C}$  to  $+50^{\circ}\text{C}$  at intervals of not more than  $10^{\circ}\text{C}$ .

(2) Primary Supply Voltage:

For hand carried battery powered equipment, the primary supply voltage is reduced to the battery operating end point which shall be specified by the manufacture. The supply voltage shall be measured at input to the cable normally provide with the equipment, or at the power supply terminals if cables are not normally provided.

### 4.2 Test Setup

For Temperature Test:

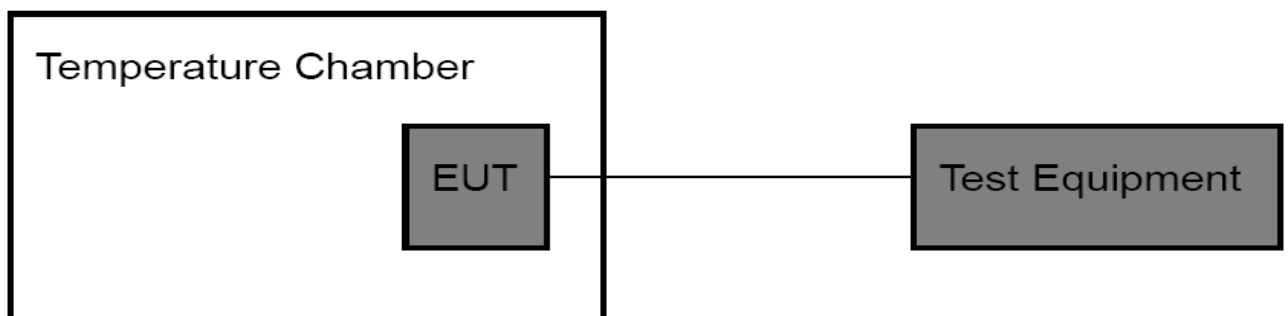

For Voltage Test:

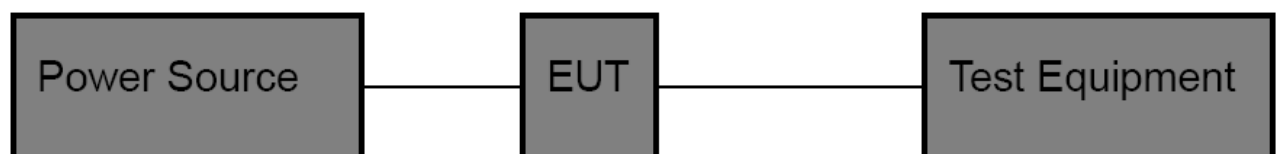

### 4.3 Test Procedure

Test Procedures for Temperature Variation:

- (1) The EUT was set up in the thermal chamber and connected with the base station.
- (2) With power off, the temperature was decreased to  $-30^{\circ}\text{C}$  and the EUT was stabilized for three hours. Power was applied and the maximum change in frequency was recorded within one minute.
- (3) With power off, the temperature was raised in  $10^{\circ}\text{C}$  set up to  $50^{\circ}\text{C}$  and the EUT was stabilized for three hours. Power was applied and the maximum change in frequency was recorded within one minute.
- (4) If the EUT cannot be turned on at  $-30^{\circ}\text{C}$ , the testing lowest temperature will be raised in  $10^{\circ}\text{C}$  step until the EUT can be turned on.

Test Procedures for Voltage Variation:

- (1) The EUT was placed in a temperature chamber at  $25 \pm 5^{\circ}\text{C}$  and connected with the base station.
- (2) Reduce the input voltage to specify extreme voltage variation ( $\pm 15\%$ ) and endpoint, record the maximum frequency change.
- (3) The variation in frequency was measured for the worst case.

### 4.4 EUT Operating Condition

The Equipment Under Test was set to Communication with the Base Station.

### 3.5 Test Data

Please refer the following pages.

### Temperature Variation

Temperature Variation GSM 850 (CH190)						
Temperature (°C)	GSM		GPRS		EDGE	
	Freq. Dev. (Hz)	Deviation (ppm)	Freq. Dev. (Hz)	Deviation (ppm)	Freq. Dev. (Hz)	Deviation (ppm)
-30	1	0.001	3	0.004	8	0.010
-20	2	0.002	2	0.002	6	0.007
-10	4	0.005	4	0.005	7	0.008
0	3	0.004	1	0.001	4	0.005
10	3	0.004	3	0.004	5	0.006
20	1	0.001	4	0.005	6	0.007
30	4	0.005	2	0.002	5	0.006
40	2	0.002	5	0.006	7	0.008
50	2	0.002	3	0.004	9	0.011
60	1	0.001	2	0.002	4	0.005
<b>Limit</b>	<b>2.5 (ppm)</b>					
<b>Result</b>	<b>PASS</b>					

Temperature Variation GSM 1900 (CH661)						
Temperature (°C)	GSM		GPRS		EDGE	
	Freq. Dev. (Hz)	Deviation (ppm)	Freq. Dev. (Hz)	Deviation (ppm)	Freq. Dev. (Hz)	Deviation (ppm)
-30	3	0.005	3	0.005	7	0.011
-20	2	0.003	4	0.006	3	0.005
-10	4	0.006	3	0.005	4	0.006
0	5	0.008	5	0.008	6	0.009
10	4	0.006	3	0.005	2	0.003
20	5	0.008	2	0.003	5	0.008
30	3	0.005	4	0.006	6	0.009
40	2	0.003	2	0.003	4	0.006
50	6	0.009	5	0.008	7	0.011
60	4	0.006	4	0.006	5	0.008
<b>Limit</b>	<b>2.5 (ppm)</b>					
<b>Result</b>	<b>PASS</b>					

Temperature Variation UMTS Band V (CH 4183)		
Temperature (°C)	RMC Mode	
	Freq. Dev. (Hz)	Deviation (ppm)
-30	13	0.016
-20	17	0.020
-10	15	0.018
0	12	0.014
10	13	0.016
20	11	0.013
30	10	0.012
40	9	0.011
50	14	0.017
60	13	0.016
<b>Limit</b>	<b>2.5 (ppm)</b>	
<b>Result</b>	<b>PASS</b>	

Temperature Variation UMTS Band II (CH 9400)		
Temperature (°C)	RMC Mode	
	Freq. Dev. (Hz)	Deviation (ppm)
-30	15	0.008
-20	12	0.006
-10	18	0.010
0	16	0.009
10	17	0.009
20	19	0.010
30	16	0.009
40	18	0.010
50	17	0.009
60	14	0.007
<b>Limit</b>	<b>2.5 (ppm)</b>	
<b>Result</b>	<b>PASS</b>	

### Voltage Variation

Voltage Variation GSM 850 (CH190)						
Voltage (V)	GSM		GPRS		EDGE	
	Freq. Dev. (Hz)	Deviation (ppm)	Freq. Dev. (Hz)	Deviation (ppm)	Freq. Dev. (Hz)	Deviation (ppm)
3.15	5	0.006	10	0.012	14	0.017
3.70	7	0.008	13	0.016	12	0.014
4.26	9	0.011	11	0.013	15	0.018
Limit	2.5 (ppm)					
Result	PASS					

Voltage Variation GSM 1900 (CH661)						
Voltage (V)	GSM		GPRS		EDGE	
	Freq. Dev. (Hz)	Deviation (ppm)	Freq. Dev. (Hz)	Deviation (ppm)	Freq. Dev. (Hz)	Deviation (ppm)
3.15	6	0.009	7	0.011	9	0.014
3.70	8	0.012	9	0.014	10	0.015
4.26	9	0.014	8	0.012	12	0.018
Limit	2.5 (ppm)					
Result	PASS					

Voltage Variation UMTS Band V (CH 4182)		
Voltage (V)	RMC Mode	
	Freq. Dev. (Hz)	Deviation (ppm)
3.15	16	0.019
3.70	15	0.018
4.26	18	0.022
Limit	2.5 (ppm)	
Result	PASS	

Voltage Variation UMTS Band II (CH 9400)		
Voltage (V)	RMC Mode	
	Freq. Dev. (Hz)	Deviation (ppm)
3.15	19	0.010
3.70	16	0.009
4.26	14	0.007
Limit	2.5 (ppm)	
Result	PASS	

## 5. Conducted RF Output Power

### 5.1 Test Standard and Limit

#### 5.1.1 Test Standard

FCC Part 2: 2.1046

FCC Part 22H : 22.913 (a)

FCC Part 24E: 24.232 (c)

#### 5.1.2 Test Limit

GSM850/UMTS Band V	PCS 1900/UMTS Band II
38.5 dBm (ERP)	33 dBm (EIRP)

### 5.2 Test Setup

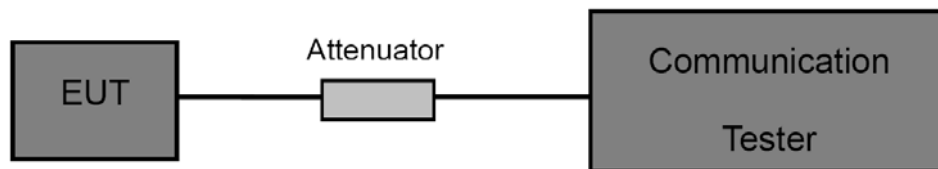

### 5.3 Test Procedure

- (1) The EUT is coupled to the Base Station with the suitable Attenuator, the path loss is calibrated to correct the reading.
- (2) A call is set up by the Base Station to the generic call set up procedure.
- (3) Set EUT at maximum power level through base station by power level command.
- (4) Then read record the power value from the Base Station in dBm.

### 5.4 EUT Operating Condition

The EUT was continuously connected with the Base station and transmitting in the max power during the test.

### 5.5 EUT Operating Condition

GSM 850				
Mode	Channel	Frequency (MHz)	Conducted Power (dBm)	Conducted Power (W)
GSM 850	128	824.2	32.74	1.879
	190	836.6	32.82	1.914
	251	848.8	32.68	1.854
GPRS 850 (1 Slot)	128	824.2	32.52	1.786
	190	836.6	32.46	1.762
	251	848.8	32.63	1.832
GPRS 850 (2 Slot)	128	824.2	31.45	1.396
	190	836.6	31.24	1.330
	251	848.8	31.54	1.426
GPRS 850 (3 Slot)	128	824.2	29.46	0.883
	190	836.6	29.53	0.897
	251	848.8	29.47	0.885
GPRS 850 (4 Slot)	128	824.2	28.14	0.652
	190	836.6	28.09	0.644
	251	848.8	28.13	0.650
EDGE 850 (1 Slot)	128	824.2	30.48	1.117
	190	836.6	30.59	1.146
	251	848.8	30.67	1.167
EDGE 850 (2 Slot)	128	824.2	29.79	0.953
	190	836.6	29.95	0.989
	251	848.8	29.86	0.968
EDGE 850 (3 Slot)	128	824.2	28.23	0.650
	190	836.6	28.26	0.670
	251	848.8	28.31	0.743
EDGE 850 (4 Slot)	128	824.2	27.26	0.583
	190	836.6	27.13	0.566
	251	848.8	27.25	0.624



PCS 1900				
Mode	Channel	Frequency (MHz)	Conducted Power (dBm)	Conducted Power (W)
GSM 1900	512	1850.2	31.55	1.429
	661	1880.0	31.24	1.330
	810	1909.8	31.56	1.432
GPRS 1900 (1 Slot)	512	1850.2	30.86	1.219
	661	1880.0	30.74	1.186
	810	1909.8	30.85	1.216
GPRS 1900 (2 Slot)	512	1850.2	29.32	0.855
	661	1880.0	29.25	0.841
	810	1909.8	29.34	0.859
GPRS 1900 (3 Slot)	512	1850.2	28.13	0.650
	661	1880.0	28.12	0.649
	810	1909.8	28.24	0.667
GPRS 1900 (4 Slot)	512	1850.2	27.09	0.512
	661	1880.0	27.08	0.511
	810	1909.8	27.12	0.515
EDGE 1900 (1 Slot)	512	1850.2	28.12	0.649
	661	1880.0	28.09	0.644
	810	1909.8	28.15	0.653
EDGE 1900 (2 Slot)	512	1850.2	27.54	0.568
	661	1880.0	27.16	0.520
	810	1909.8	27.35	0.543
EDGE 1900 (3 Slot)	512	1850.2	26.74	0.472
	661	1880.0	26.53	0.450
	810	1909.8	26.19	0.416
EDGE 1900 (4 Slot)	512	1850.2	25.14	0.327
	661	1880.0	25.26	0.336
	810	1909.8	25.18	0.330

UMTS Band V				
Mode	Channel	Frequency (MHz)	Conducted Power (dBm)	Conducted Power (W)
Band V RMC	4132	826.4	22.78	0.190
	4183	836.6	22.84	0.192
	4233	846.6	22.94	0.197
HSDPA Subtest 1	4132	826.4	21.58	0.144
	4183	836.6	21.54	0.143
	4233	846.6	21.62	0.145
HSDPA Subtest 2	4132	826.4	21.26	0.134
	4183	836.6	21.38	0.137
	4233	846.6	21.45	0.140
HSDPA Subtest 3	4132	826.4	20.68	0.117
	4183	836.6	20.73	0.118
	4233	846.6	20.59	0.115
HSDPA Subtest 4	4132	826.4	20.84	0.121
	4183	836.6	20.76	0.119
	4233	846.6	20.65	0.116
HSUPA Subtest 1	4132	826.4	21.22	0.132
	4183	836.6	21.42	0.139
	4233	846.6	21.33	0.136
HSUPA Subtest 2	4132	826.4	21.16	0.131
	4183	836.6	21.24	0.133
	4233	846.6	21.19	0.132
HSUPA Subtest 3	4132	826.4	21.03	0.127
	4183	836.6	21.08	0.128
	4233	846.6	21.09	0.129
HSUPA Subtest 4	4132	826.4	20.36	0.109
	4183	836.6	19.86	0.097
	4233	846.6	20.25	0.106
HSUPA Subtest 5	4132	826.4	19.69	0.093
	4183	836.6	20.04	0.101
	4233	846.6	19.78	0.095

UMTS Band II				
Mode	Channel	Frequency (MHz)	Conducted Power (dBm)	Conducted Power (W)
Band II RMC	9262	1852.4	20.38	0.109
	9400	1880.0	20.68	0.117
	9538	1907.6	20.85	0.122
HSDPA Subtest 1	9262	1852.4	20.67	0.117
	9400	1880.0	20.58	0.114
	9538	1907.6	20.55	0.114
HSDPA Subtest 2	9262	1852.4	20.49	0.112
	9400	1880.0	20.16	0.104
	9538	1907.6	20.14	0.103
HSDPA Subtest 3	9262	1852.4	19.85	0.097
	9400	1880.0	19.79	0.095
	9538	1907.6	19.74	0.094
HSDPA Subtest 4	9262	1852.4	20.11	0.103
	9400	1880.0	19.77	0.095
	9538	1907.6	20.06	0.101
HSUPA Subtest 1	9262	1852.4	20.54	0.113
	9400	1880.0	20.38	0.109
	9538	1907.6	20.49	0.112
HSUPA Subtest 2	9262	1852.4	20.15	0.104
	9400	1880.0	20.46	0.111
	9538	1907.6	20.79	0.120
HSUPA Subtest 3	9262	1852.4	19.85	0.097
	9400	1880.0	19.95	0.099
	9538	1907.6	19.64	0.092
HSUPA Subtest 4	9262	1852.4	19.25	0.084
	9400	1880.0	19.76	0.095
	9538	1907.6	20.01	0.100
HSUPA Subtest 5	9262	1852.4	19.57	0.091
	9400	1880.0	19.52	0.090
	9538	1907.6	19.84	0.096

## 6. Peak-Average Ratio

### 6.1 Test Standard and Limit

#### 6.1.1 Test Standard

FCC Part 24E: 24.232 (d)

#### 6.1.2 Test Limit

### PCS 1900 /UMTS Band II

The peak-to-average ratio (PAR) of the transmission may not exceed 13 dB.

### 6.2 Test Setup

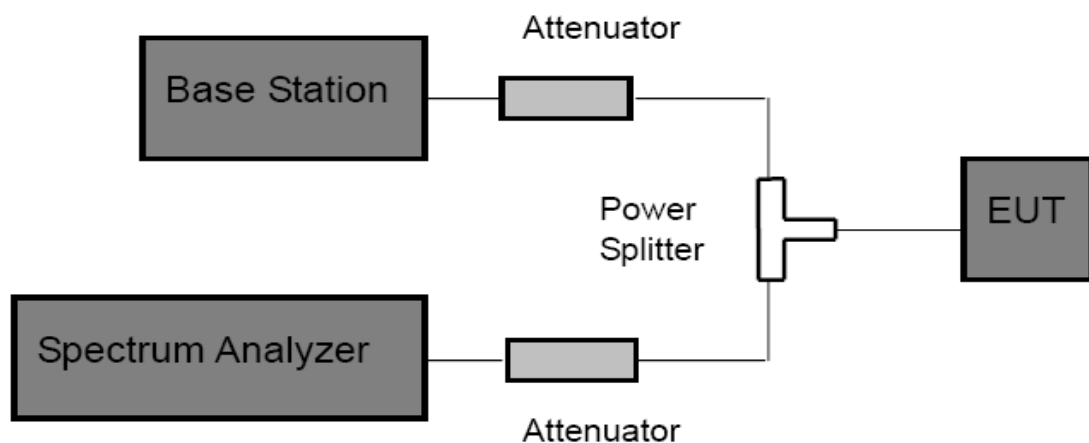

### 6.3 Test Procedure

According with KDB 971168

- (1) The signal analyzer's CCDF measurement profile is enabled.
- (2) Frequency = carrier center frequency.
- (3) Measurement BW > Emission bandwidth of signal.
- (4) The signal analyzer was set to collect one million samples to generate the CCDF curve.
- (5) The measurement interval was set depending on the type of signal analyzed. For continuous signals (>98% duty cycle), the measurement interval was set to 1ms. For burst transmissions, the spectrum analyzer is set to use an internal "RF Burst" trigger that is synced with an incoming pulse and the measurement interval is set to less than the duration of the "on time" of one burst to ensure that energy is only captured during a time in which of the transmitter is operating at maximum power.

### 6.4 EUT Operating Condition

The EUT was continuously connected with the Base station and transmitting in the max power

during the test.

### 6.5 Test Data

PCS 1900			
Mode	Channel	Frequency (MHz)	Peak-Average Ratio (PAR)
PCS 1900	512	1850.2	0.035
	661	1880.0	0.003
	810	1909.8	0.021

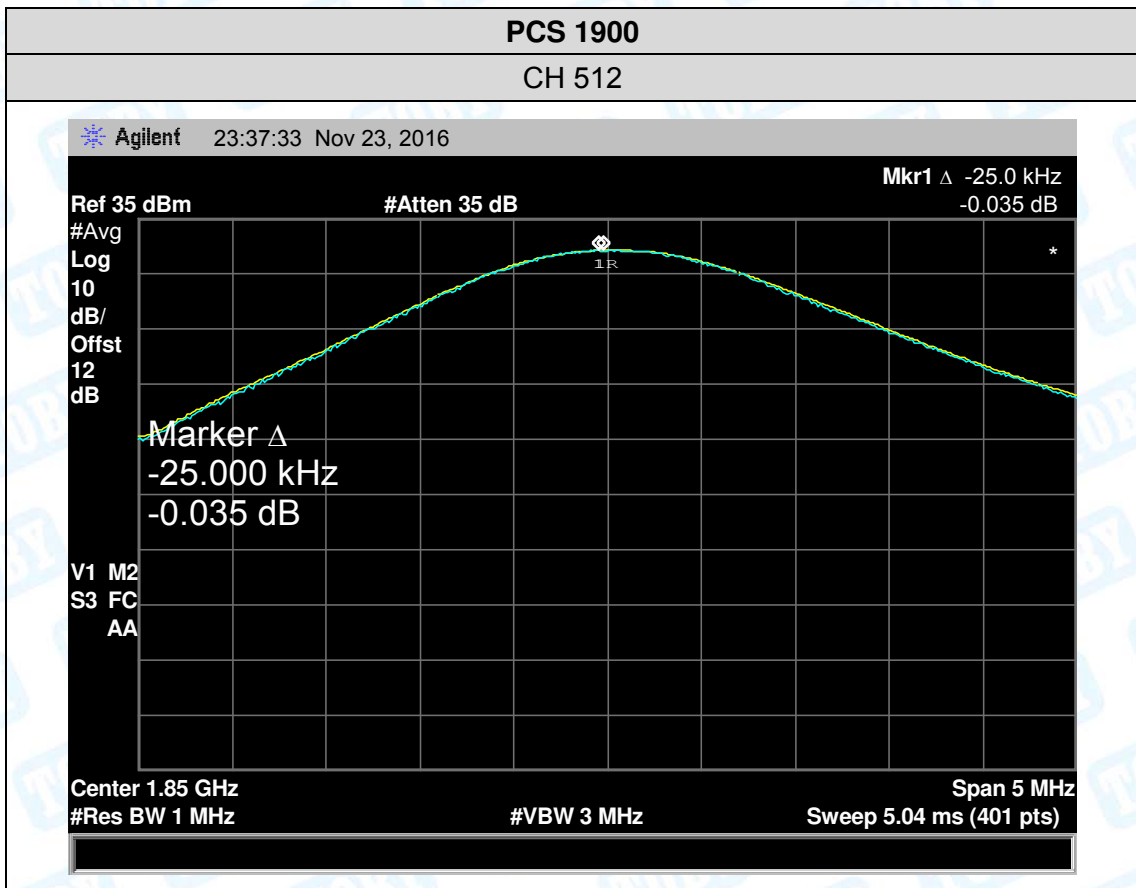

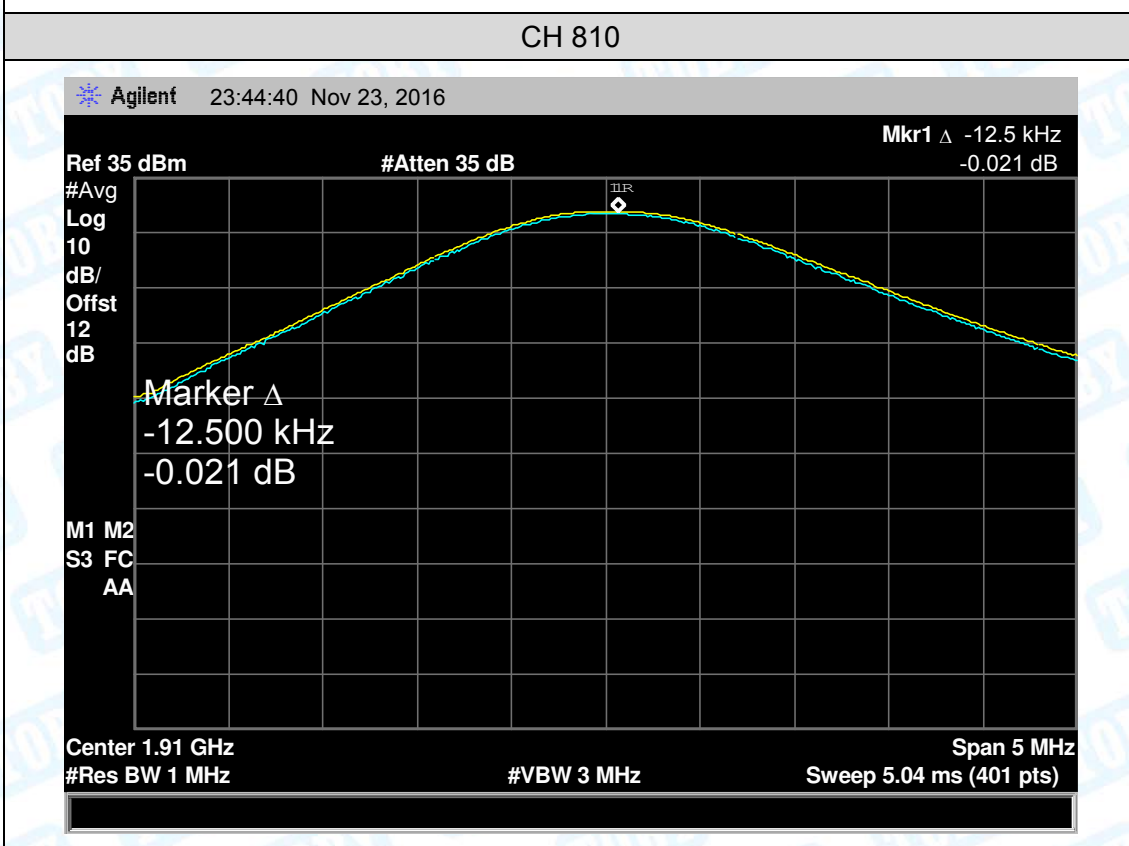
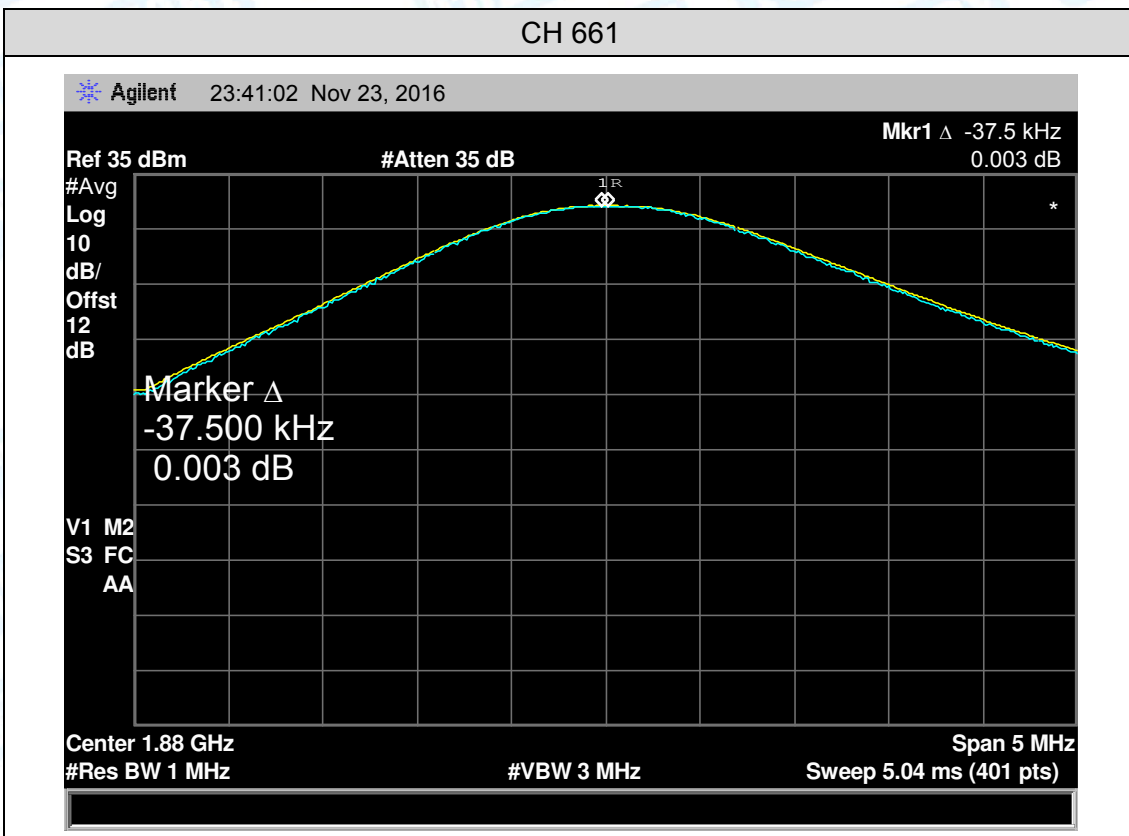

UMTS Band II			
Mode	Channel	Frequency (MHz)	Peak-Average Ratio (PAR)
UMTS Band II	9262	1852.4	3.16
	9400	1880.0	3.33
	9538	1907.6	3.20

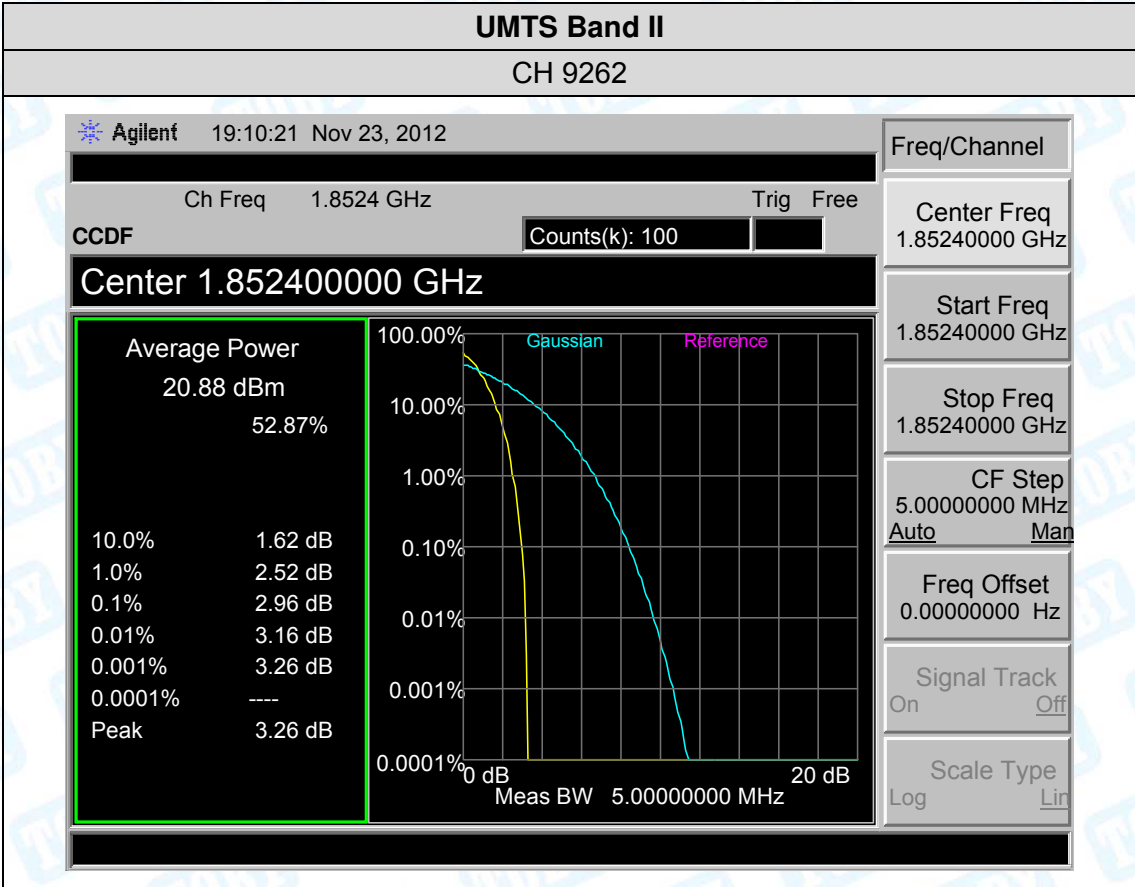

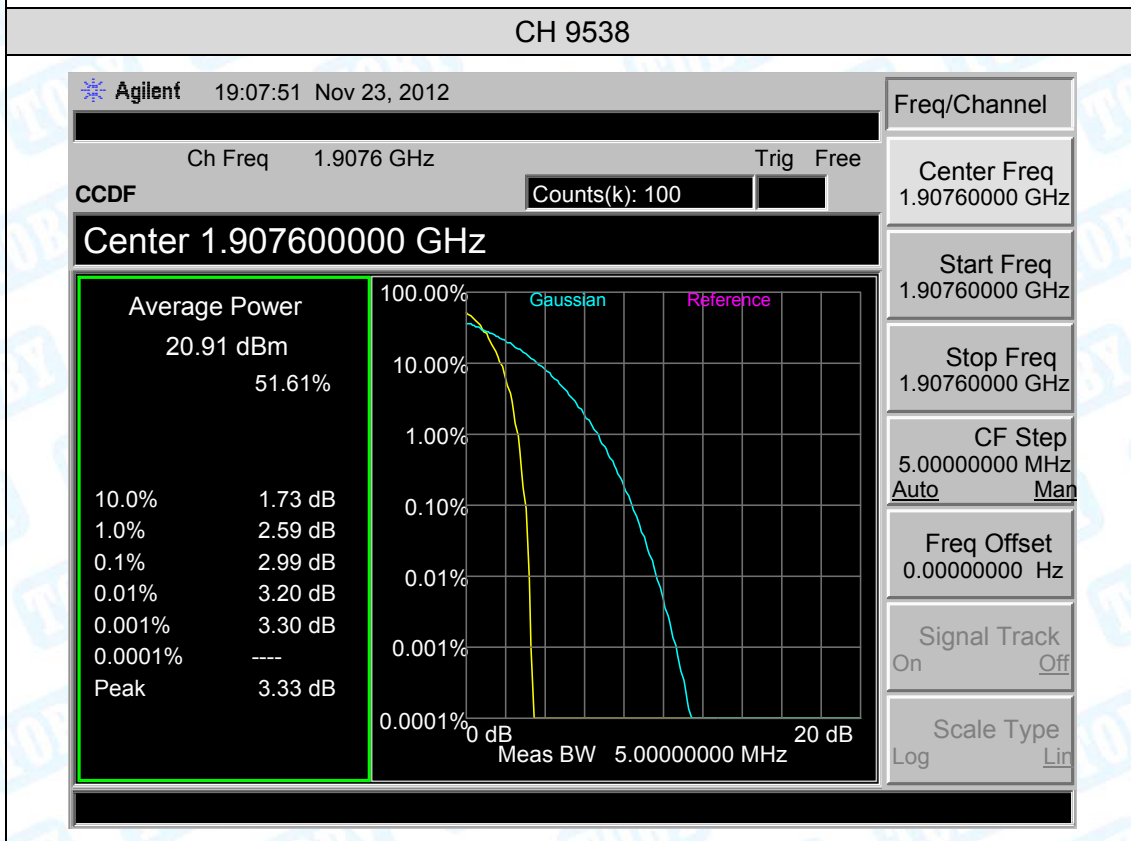
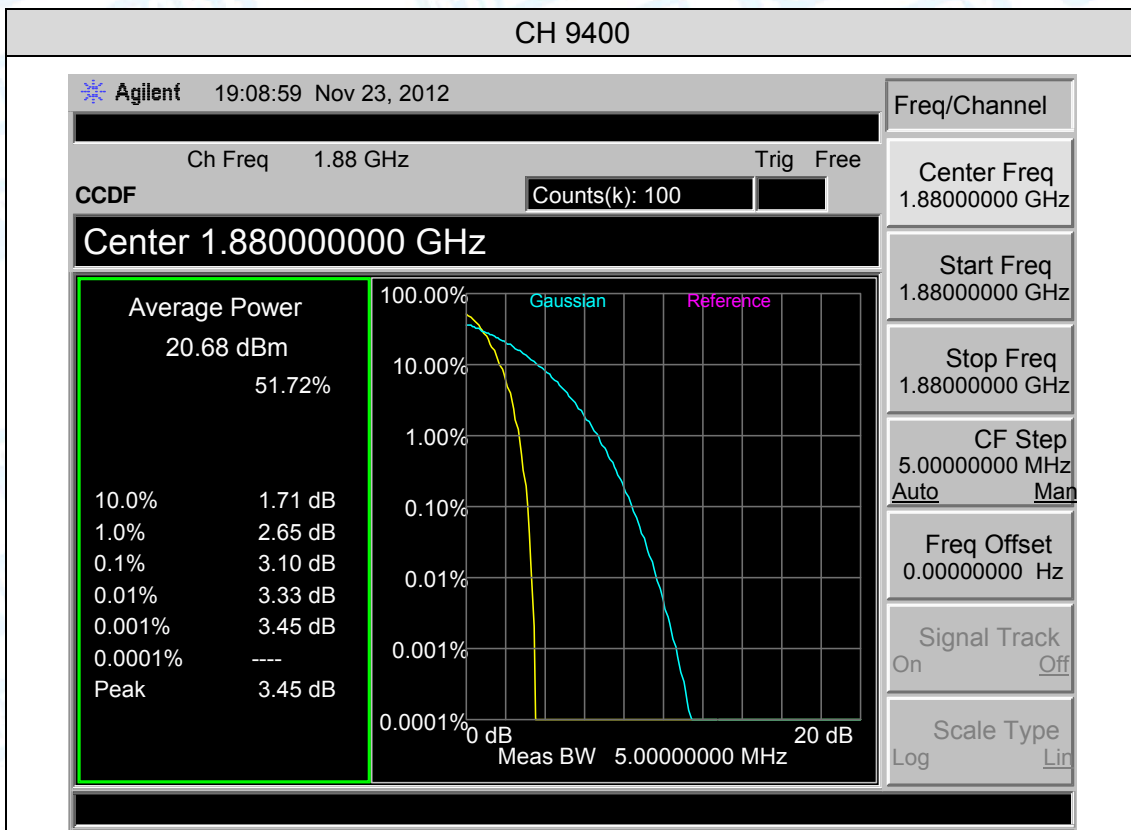



## 7. Radiated Output Power

### 7.1 Test Standard and Limit

#### 7.1.1 Test Standard

FCC Part 22H : 22.913 (a)

FCC Part 24E: 24.232 (c)

#### 7.1.2 Test Limit

According to FCC Part 22.913 (a), the ERP of Cellular mobile transmitters must not exceed 7 Watts(38.5 dBm).

According to FCC Part 24.232 (c), the Mobile/portable stations are limited to 2 Watts(33 dBm) EIRP peak power.

Cellular Band		PCS Band	
GSM850	UMTS Band V	PCS 1900	UMTS Band II
38.5 dBm (ERP)		33 dBm (EIRP)	

### 7.2 Test Setup

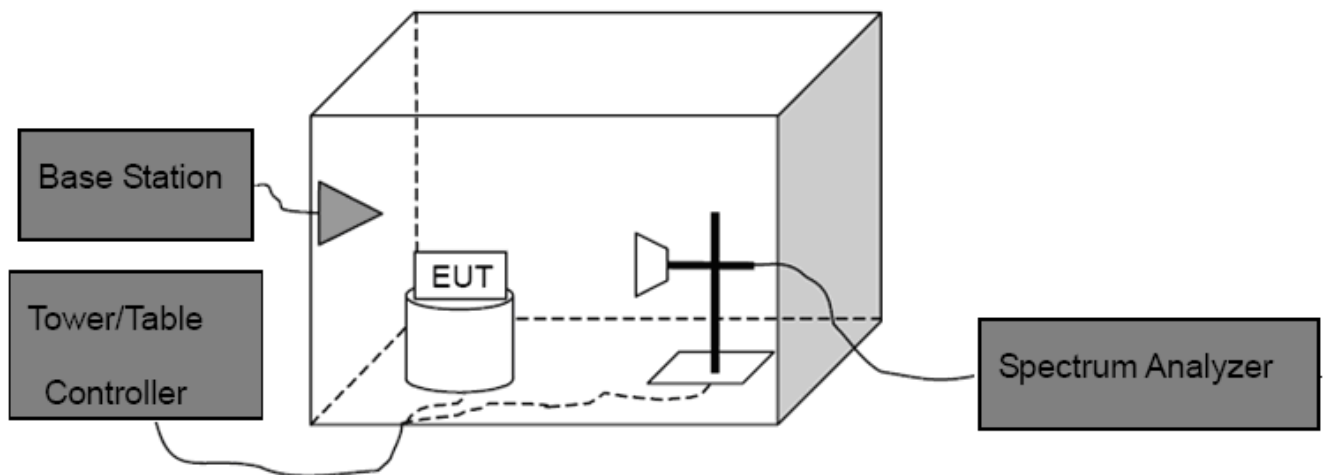

Above 1G

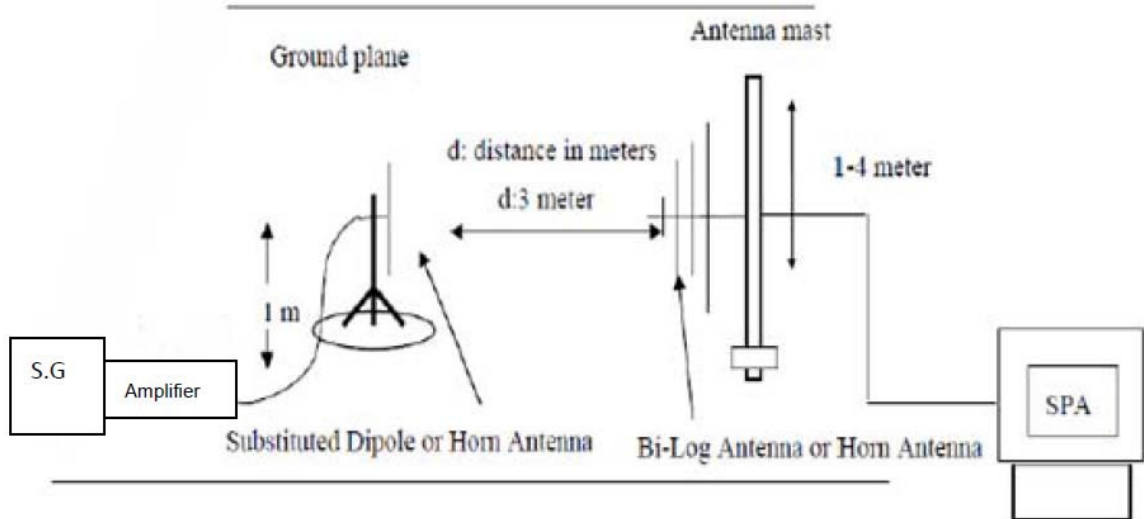

### Substituted Method

#### 7.3 Test Procedure

- (1) The EUT was placed on a non-conductive rotating platform with 0.8 meter height in an anechoic chamber. The radiated emission at the fundamental frequency was measured at 3 m with a test antenna and a spectrum analyzer with RBW=3 MHz, VBW=3 MHz and peak detector settings.
- (2) During the measurement, the EUT was enforced in maximum power and linked with the Base Station. The highest was recorded from analyzer power level (LVT) from the 360 degrees rotation of the turntable and the test antenna raised and lowered over a range from 1 to 4 meters in both horizontally and vertically polarized orientations.
- (3) Effective Isotropic Radiated Power (EIRP) was measured by substitution method according to C63.26. The EUT was replaced by dipole antenna (for frequency below 1 GHz) or Horn antenna (for frequency above 1 GHz) at same location with same polarize of receiver antenna and then a known power of each measure frequency from S.G. was applied into the dipole antenna or Horn antenna through a TX cable, and then recorded the maximum Analyzer reading through raised and lowered the test antenna.

**Note: In test, the S.G. Connect the Pre-amplifier(Sonoma 310N Pre-amplifier for frequency below 1 GHz, HP 8449B Pre-amplifier for frequency above 1 GHz )**

Then the EUT's EIRP and ERP was calculated with the correction factor:  
 $ERP = S.G. Level + Antenna Gain Cord. (dBd) - Cable Loss (dB)$   
 $EIRP = S.G. Level + Antenna Gain Cord. (dBi) - Cable Loss (dB)$

#### 7.4 EUT Operating Condition

The EUT was continuously connected with the Base station and transmitting in the max power during the test.

## 7.5 Test Data

### Measurement Data (worst case)

GSM 850								
Mode	Channel	Frequency (MHz)	Antenna (H&V)	SG Level (dBm)	Antenna Factor (dBd)	Cable Loss (dB)	ERP Power (dBm)	ERP Power (W)
GSM 850	128	824.2	H	28.78	3.46	1.26	30.98	1.253
			V	26.15	3.46	1.26	28.35	0.684
	190	836.6	H	28.19	3.82	1.26	30.75	1.189
			V	25.57	3.82	1.26	28.13	0.650
	251	848.8	H	27.76	4.16	1.26	30.66	1.164
			V	25.19	4.16	1.26	28.09	0.644
GPRS 850 (1 Slot)	128	824.2	H	28.22	3.46	1.26	30.42	1.102
			V	25.76	3.46	1.26	27.96	0.625
	190	836.6	H	27.49	3.82	1.26	30.05	1.012
			V	25.30	3.82	1.26	27.86	0.611
	251	848.8	H	27.13	4.16	1.26	30.03	1.007
			V	24.79	4.16	1.26	27.69	0.587
EDGE 850 (1 Slot)	128	824.2	H	26.15	3.46	1.26	28.35	0.684
			V	24.07	3.46	1.26	26.27	0.424
	190	836.6	H	25.90	3.82	1.26	28.46	0.701
			V	23.90	3.82	1.26	26.46	0.443
	251	848.8	H	25.79	4.16	1.26	28.69	0.740
			V	23.84	4.16	1.26	26.74	0.472
<b>Limit</b>							<b>38.5</b>	<b>7</b>

PCS 1900								
Mode	Channel	Frequency (MHz)	Antenna (H&V)	SG Level (dBm)	Antenna Factor (dBi)	Cable Loss (dB)	EIRP Power (dBm)	EIRP Power (W)
GSM 1900	512	1850.2	H	27.82	5.01	2.59	30.24	1.057
			V	25.73	5.01	2.59	28.15	0.653
	661	1880.0	H	27.99	4.82	2.59	30.22	1.052
			V	26.19	4.82	2.59	28.42	0.695
	810	1909.8	H	28.26	4.45	2.59	30.12	1.028
			V	26.20	4.45	2.59	28.06	0.640
GPRS 1900 (1 Slot)	512	1850.2	H	26.83	5.01	2.59	29.25	0.841
			V	24.73	5.01	2.59	27.15	0.519
	661	1880.0	H	27.13	4.82	2.59	29.36	0.863
			V	25.01	4.82	2.59	27.24	0.530
	810	1909.8	H	27.45	4.45	2.59	29.31	0.853
			V	25.79	4.45	2.59	27.65	0.582
EDGE 1900 (1 Slot)	512	1850.2	H	25.72	5.01	2.59	28.14	0.652
			V	23.67	5.01	2.59	26.09	0.406
	661	1880.0	H	26.31	4.82	2.59	28.54	0.714
			V	24.18	4.82	2.59	26.41	0.438
	810	1909.8	H	26.60	4.45	2.59	28.46	0.701
			V	24.28	4.45	2.59	26.14	0.411
<b>Limit</b>							<b>33</b>	<b>2</b>

UMTS Band V								
Mode	Channel	Frequency (MHz)	Antenna (H&V)	SG Level (dBm)	Antenna Factor (dBi)	Cable Loss (dB)	EIRP Power (dBm)	EIRP Power (W)
Band V RMC	4132	826.4	H	18.25	3.46	1.26	20.45	0.1109
			V	16.04	3.46	1.26	18.24	0.0667
	4183	836.6	H	17.90	3.82	1.26	20.46	0.1112
			V	15.88	3.82	1.26	18.44	0.0698
	4233	846.6	H	17.78	4.16	1.26	20.68	0.1169
			V	15.48	4.16	1.26	18.38	0.0689
<b>Limit</b>							<b>38.5</b>	<b>7</b>

UMTS Band II								
Mode	Channel	Frequency (MHz)	Antenna (H&V)	SG Level (dBm)	Antenna Factor (dBi)	Cable Loss (dB)	EIRP Power (dBm)	EIRP Power (W)
Band II RMC	9262	1852.4	H	16.26	5.01	2.59	18.68	0.074
			V	14.61	5.01	2.59	17.03	0.050
	9400	1880.0	H	16.63	4.82	2.59	18.86	0.077
			V	14.66	4.82	2.59	16.89	0.049
	9538	1907.6	H	16.68	4.45	2.59	18.54	0.071
			V	14.38	4.45	2.59	16.24	0.042
<b>Limit</b>							<b>33</b>	<b>2</b>

## 8. Occupied Bandwidth

### 8.1 Test Standard and Limit

#### 8.1.1 Test Standard

FCC Part 2: 2.1049

FCC Part 22H : 22.913 (a)

FCC Part 24E: 24.232 (c)

#### 8.1.2 Test Requirement

According to FCC section 2.1049, the occupied bandwidth is the frequency bandwidth such that below its lower and above its upper frequency limits, the mean powers radiated are each equal to 0.5 percent of the total mean power radiated by a given emission.

Occupied bandwidth is also known as 99% power and -26dBC occupied bandwidths.

### 8.2 Test Setup

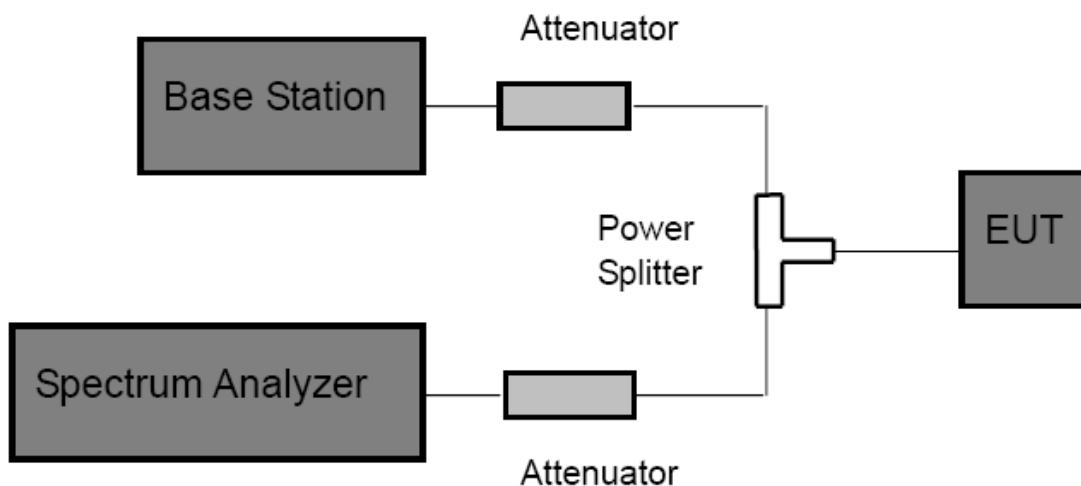

### 8.3 Test Procedure

- (1) The EUT was directly connected to the spectrum analyzer and Base station via power splitter as show in the block diagram above.
- (2) The resolution bandwidth of the Spectrum Analyzer is set to at least 1% of the occupied bandwidth.
- (3) The low, middle and the high channels are selected to perform tests respectively.
- (4) Set the frequency range of the Spectrum Analyzer suitably to capture the waveform; search peak; make a line whose value is 26dB lower than the peak; mark two points which the line intersected the waveform at; finally record the delta of the two points as the occupied bandwidth and the plot.
- (5) Set the Spectrum Analyzer Occupied bandwidth function to measure the 99% occupied bandwidth.

## 8.4 EUT Operating Condition

The EUT was continuously connected with the Base station and transmitting in the max power during the test.

## 8.5 Test Data

Please refer following pages.

GSM 850				
Mode	Channel	Frequency (MHz)	99% OBW (MHz)	-26dB Bandwidth (kHz)
GSM 850	128	824.2	246.6310	319.415
	190	836.6	246.6644	317.912
	251	848.8	245.1980	323.348
GPRS 850 (1 Slot)	128	824.2	247.7950	318.432
	190	836.6	245.1771	304.595
	251	848.8	249.9269	321.046
EDGE 850 (1 Slot)	128	824.2	253.7567	317.341
	190	836.6	245.9003	316.708
	251	848.8	254.1974	319.991
PCS 1900				
Mode	Channel	Frequency (MHz)	99% OBW (MHz)	-26dB Bandwidth (kHz)
GSM 1900	512	1850.2	246.9803	317.045
	661	1880.0	249.5084	320.669
	810	1909.8	243.5095	319.690
GPRS 1900 (1 Slot)	512	1850.2	239.4862	321.108
	661	1880.0	242.4449	318.289
	810	1909.8	249.6045	311.445
EDGE 1900 (1 Slot)	512	1850.2	248.8323	313.840
	661	1880.0	251.7689	321.557
	810	1909.8	248.5817	310.754



UMTS Band V				
Mode	Channel	Frequency (MHz)	99% OBW (MHz)	-26dB Bandwidth (MHz)
Band V RMC	4132	826.4	4.2111	4.847
	4183	836.6	4.2146	4.921
	4233	846.6	4.2308	4.914
Band V HSDPA	4132	826.4	4.2110	4.892
	4183	836.6	4.2111	4.847
	4233	846.6	4.2059	4.887
Band V HSUPA	4132	826.4	4.2196	4.919
	4183	836.6	4.2235	4.916
	4233	846.6	4.2059	4.875
UMTS Band II				
Mode	Channel	Frequency (MHz)	99% OBW (MHz)	-26dB Bandwidth (MHz)
Band II RMC	9262	1852.4	4.2238	4.897
	9400	1880.0	4.2437	4.884
	9538	1907.6	4.2122	4.886
Band II HSDPA	9262	1852.4	4.2154	4.868
	9400	1880.0	4.2090	4.877
	9538	1907.6	4.2205	4.888
Band II HSUPA	9262	1852.4	4.2191	4.894
	9400	1880.0	4.2240	4.808
	9538	1907.6	4.2385	4.853

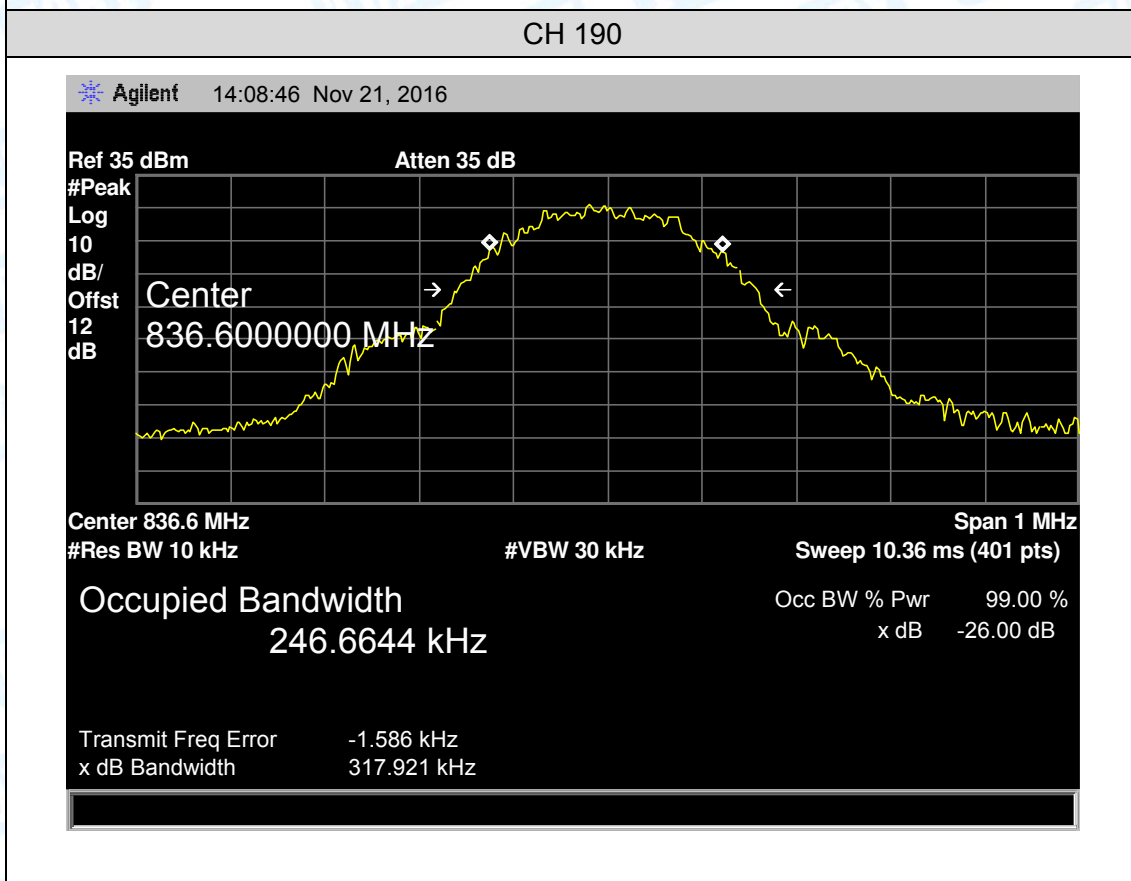
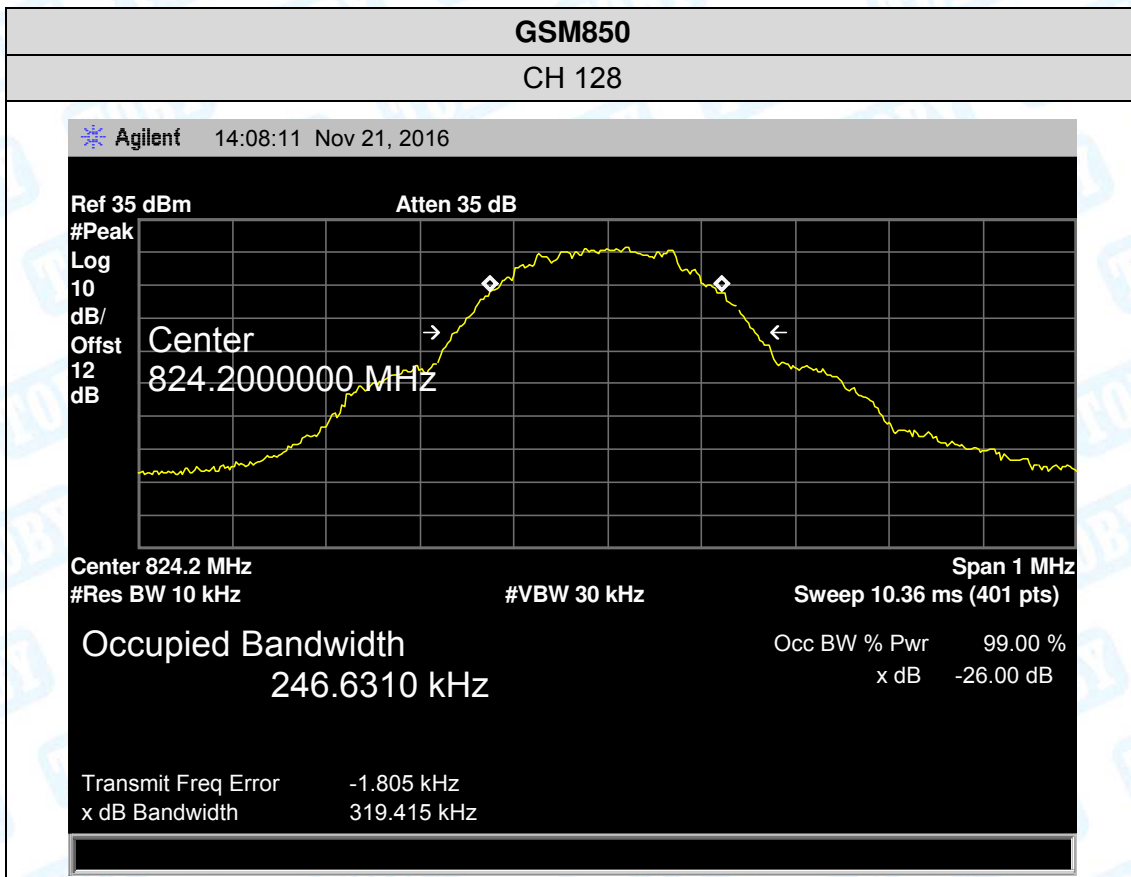

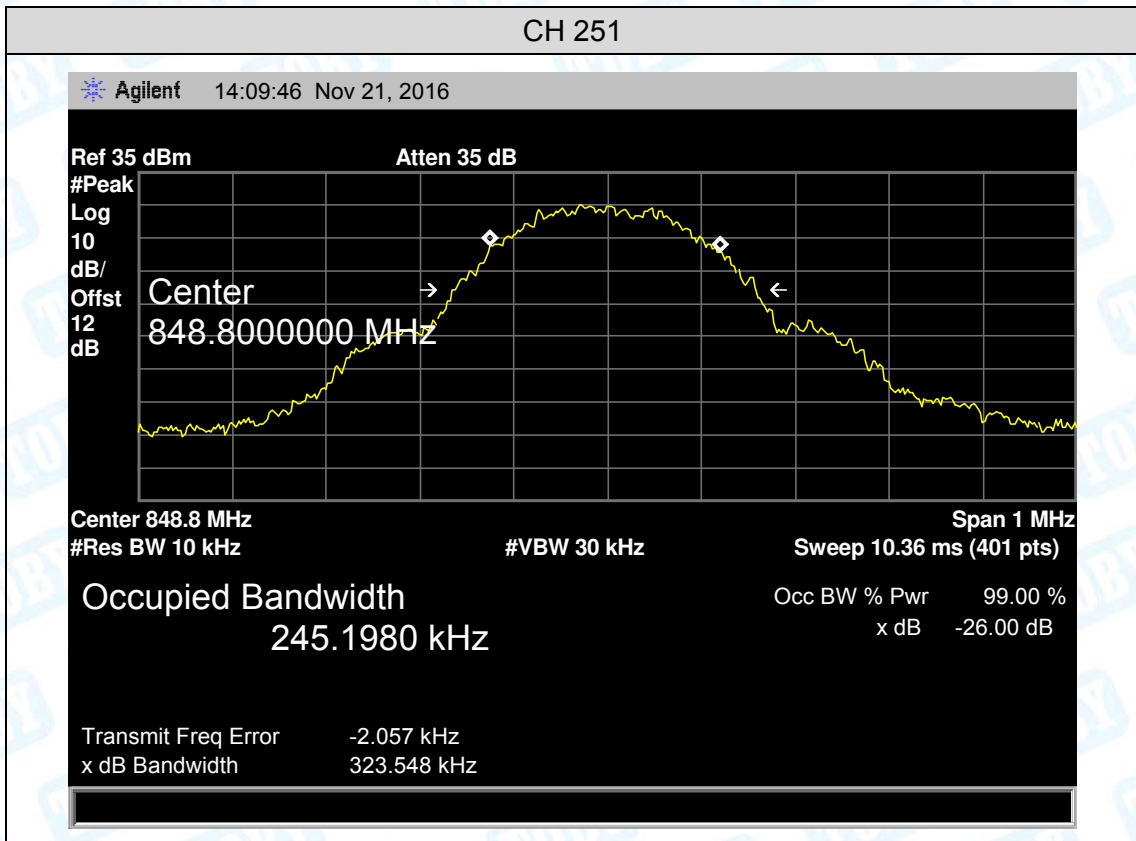

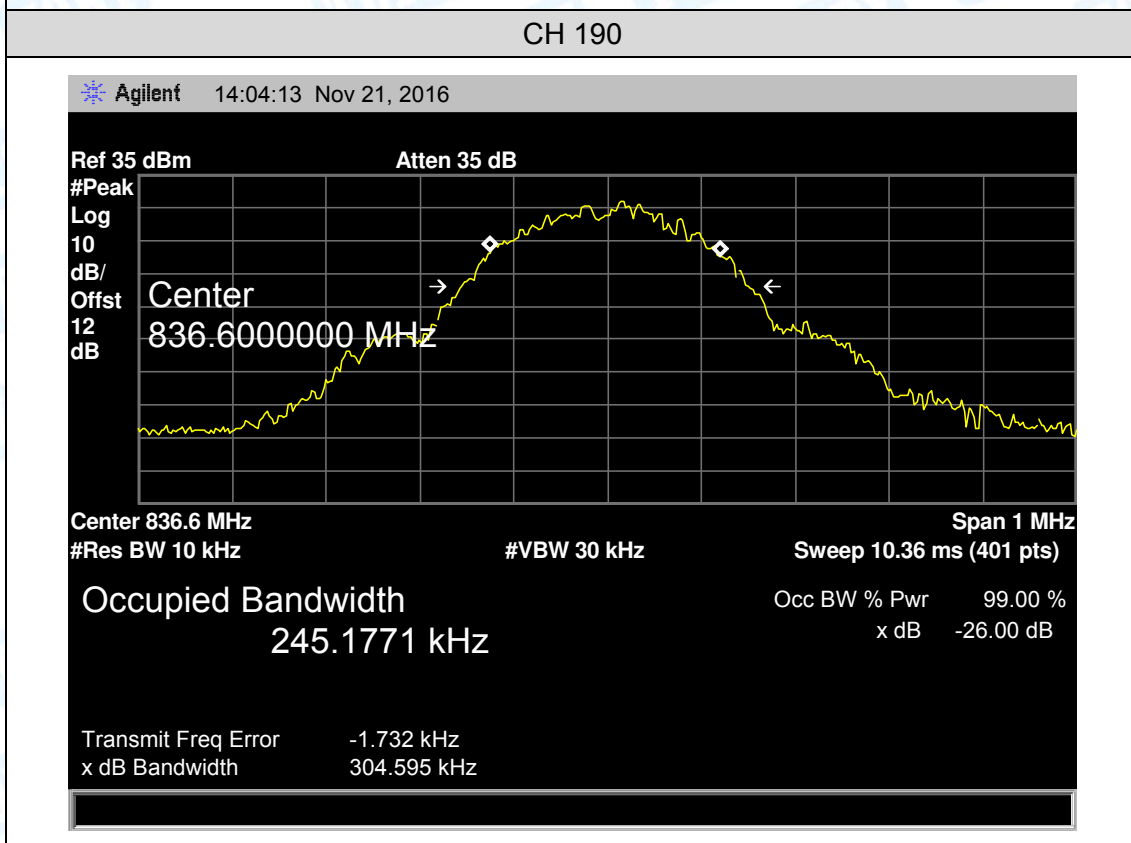
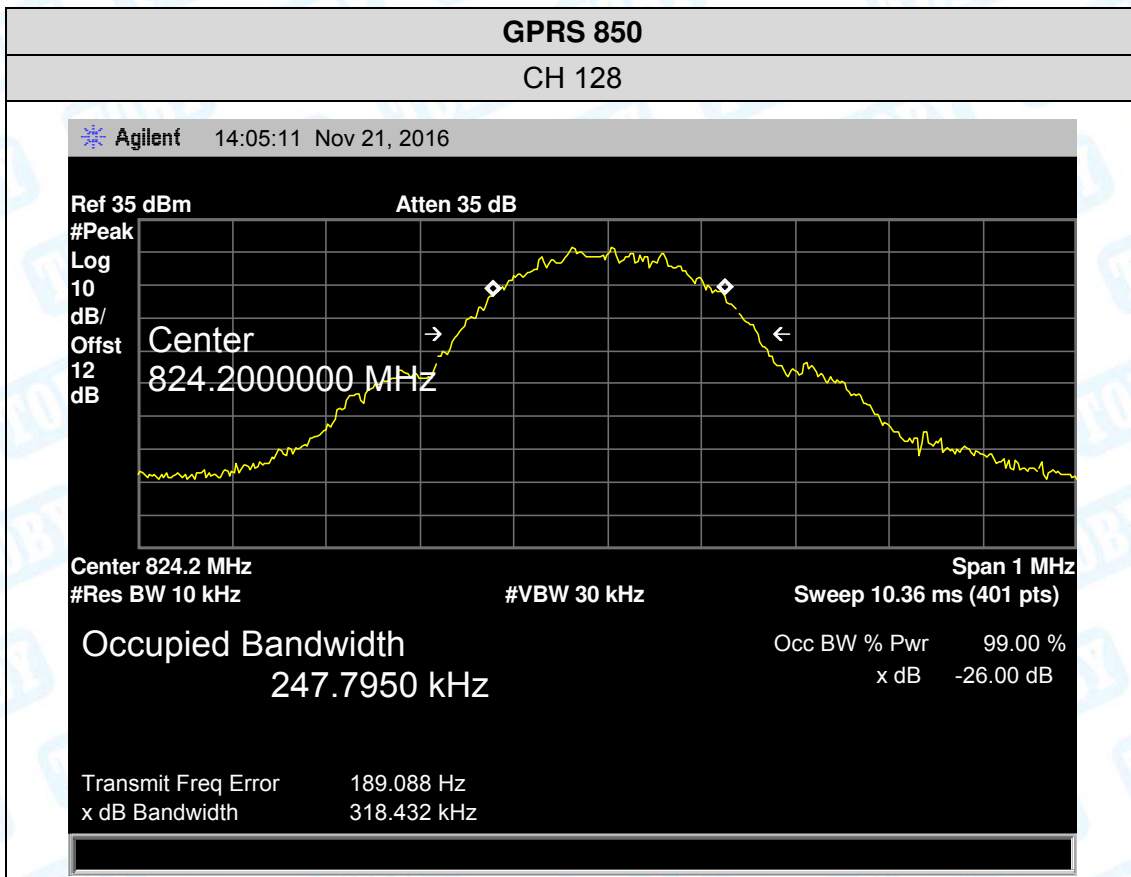

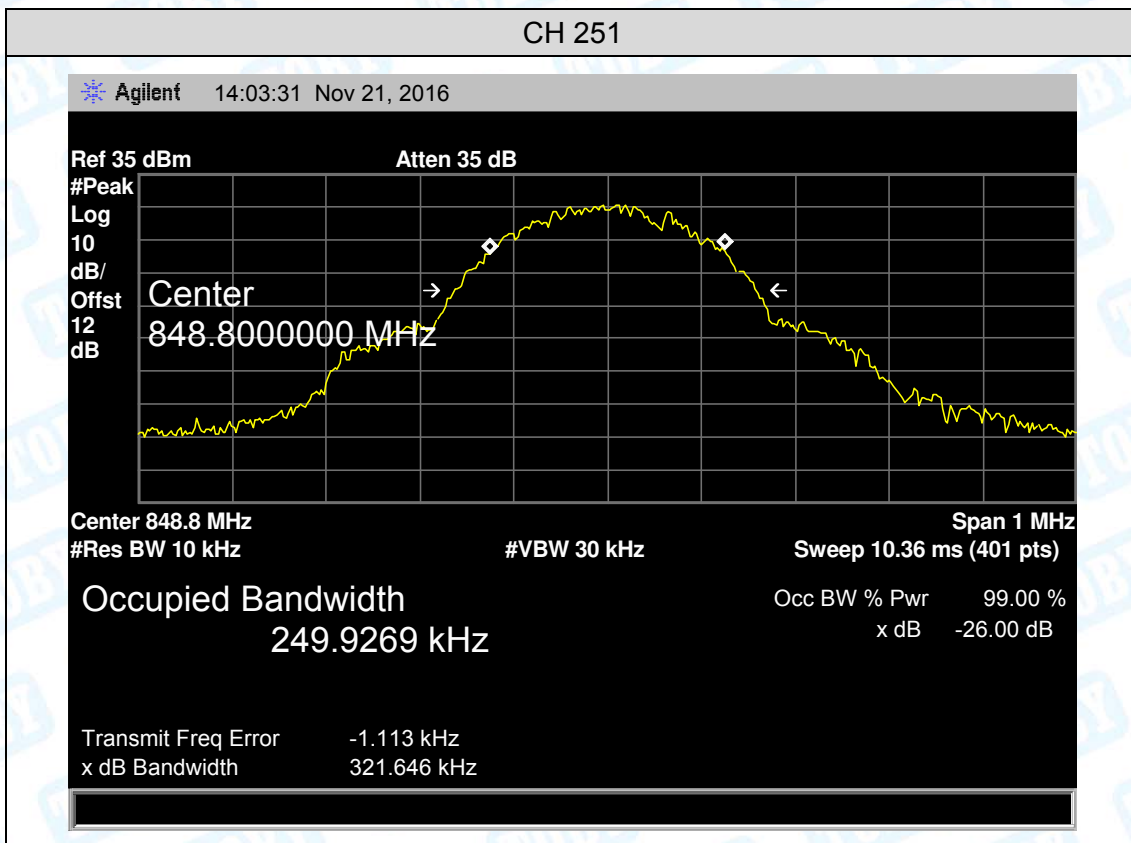

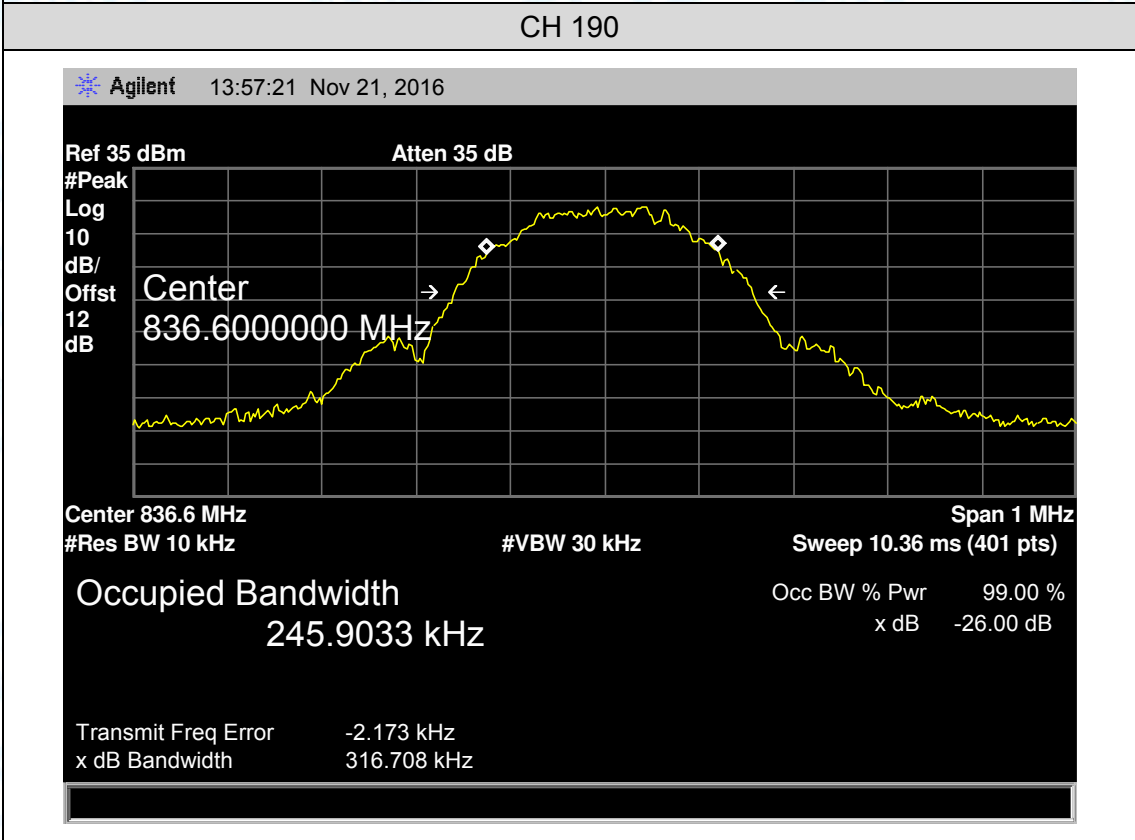
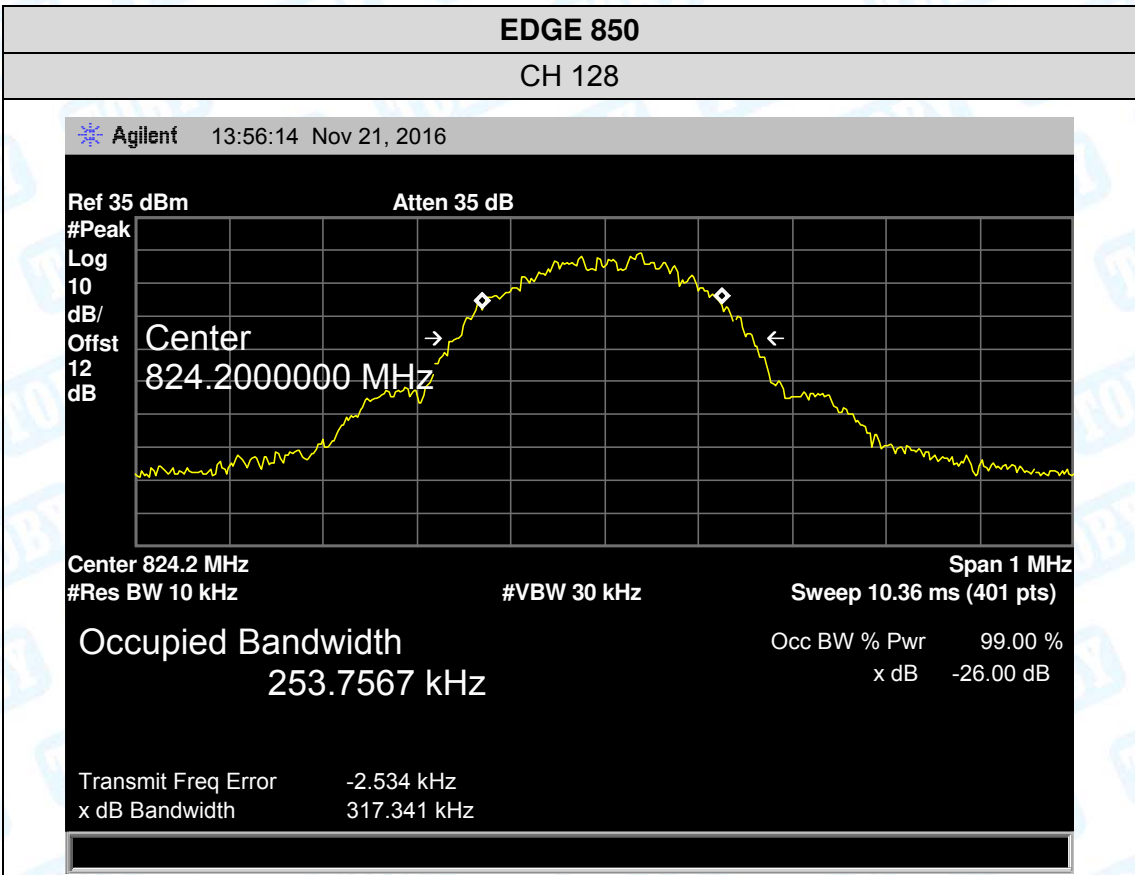

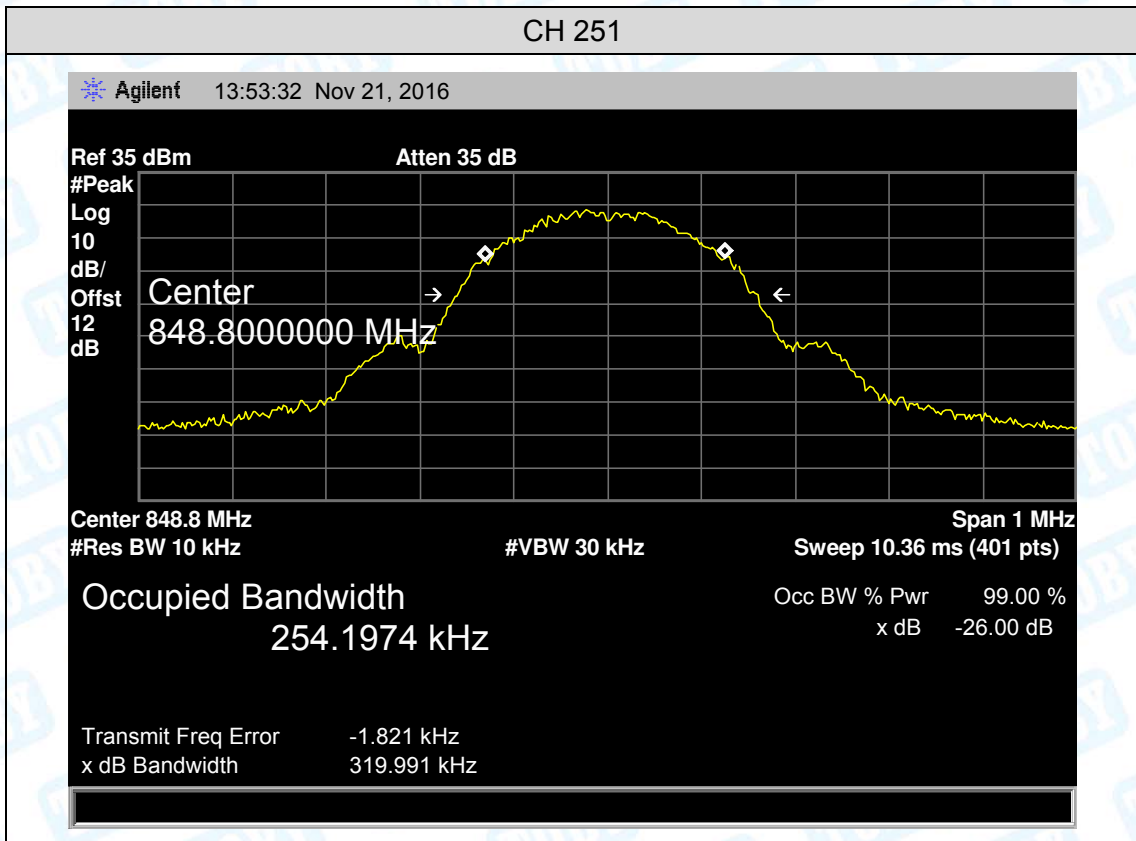

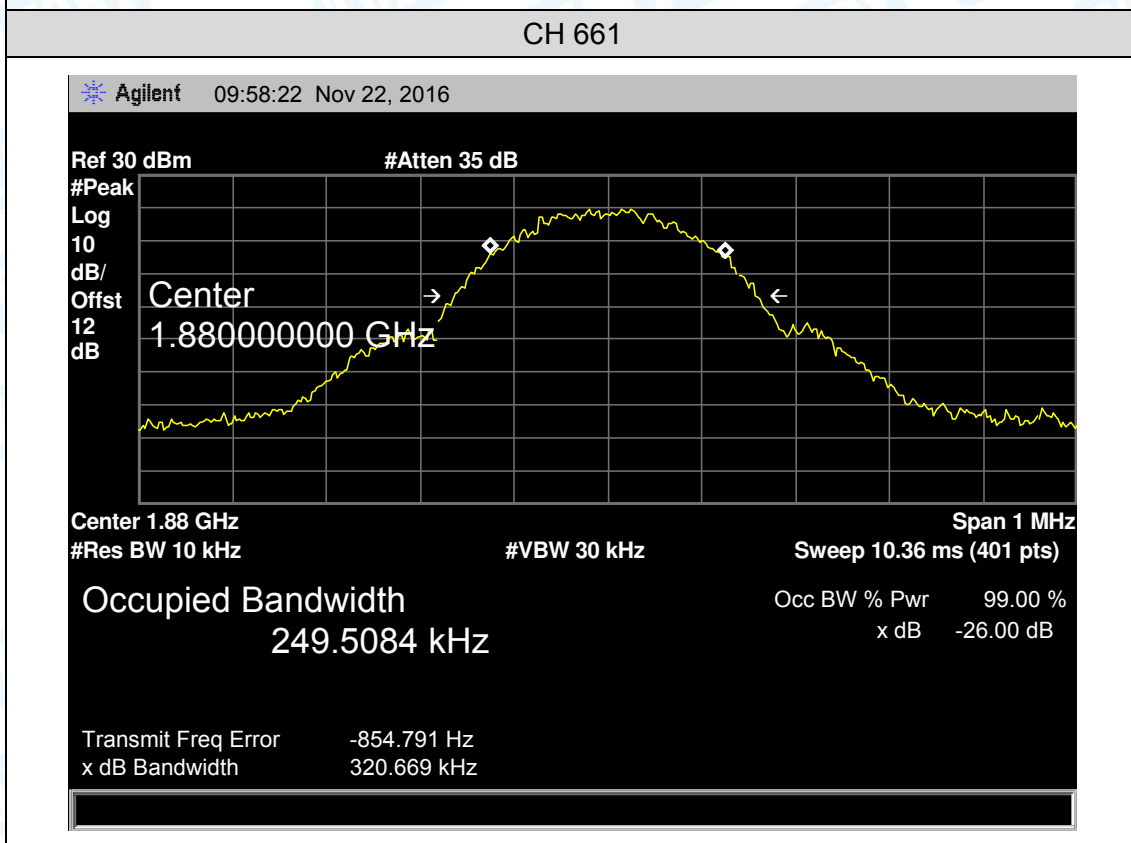
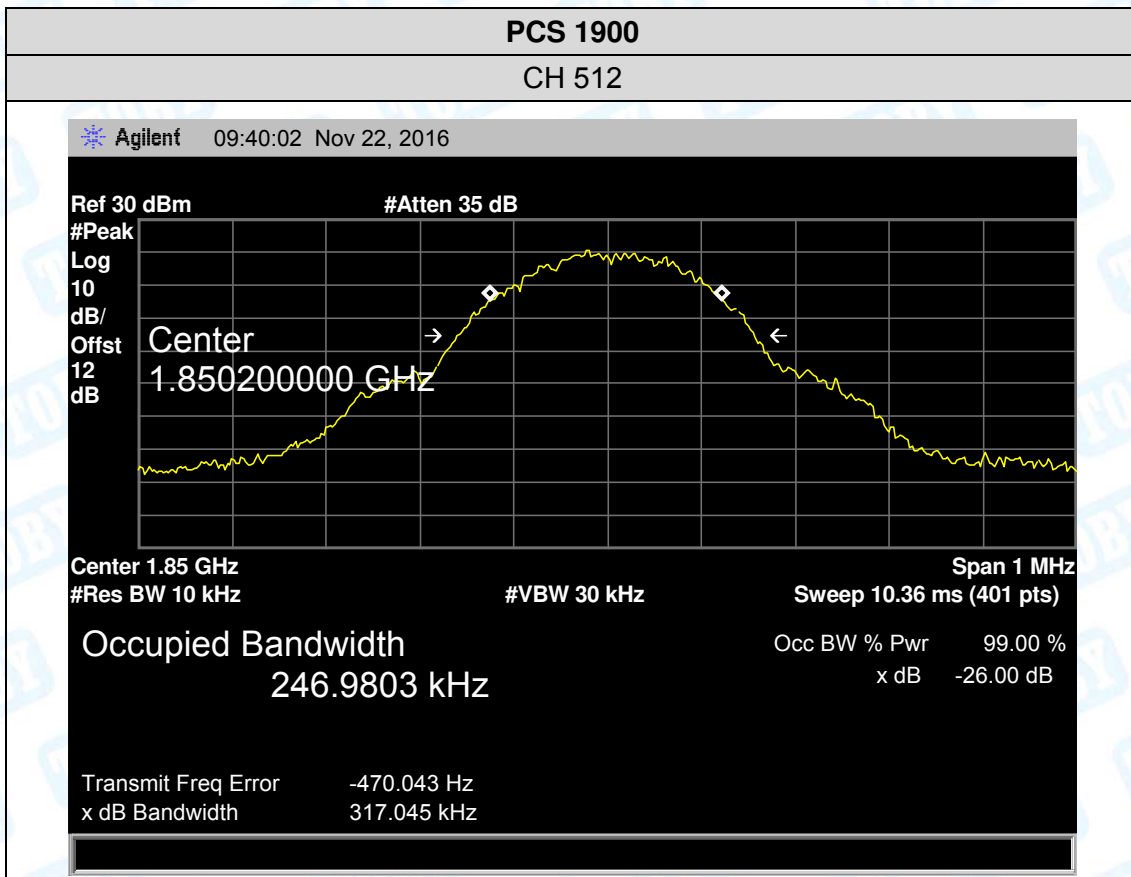



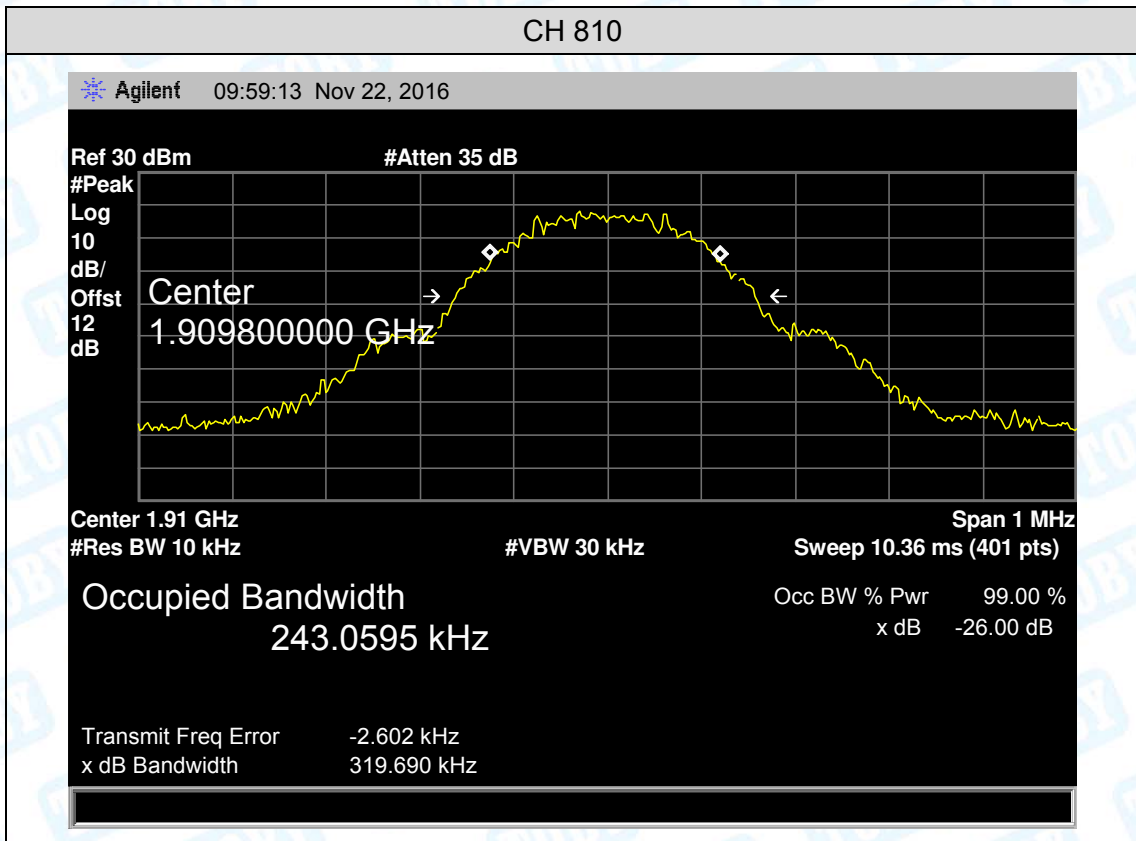

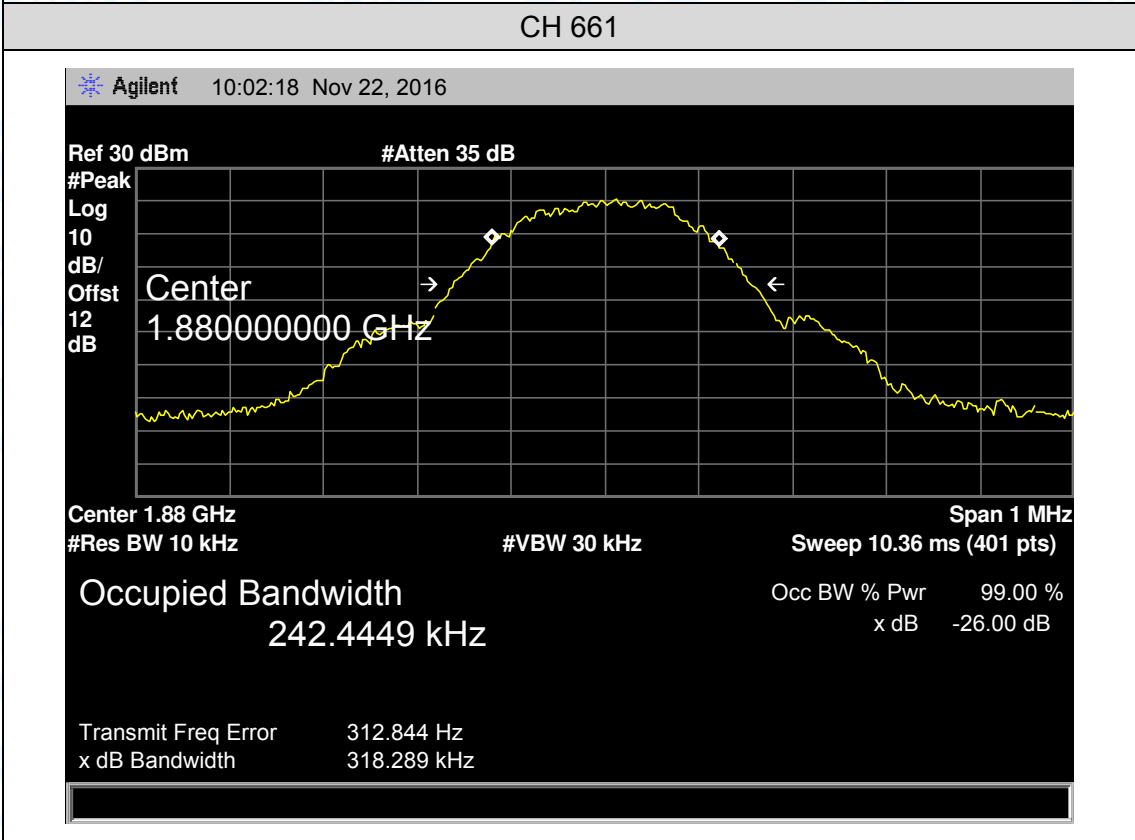
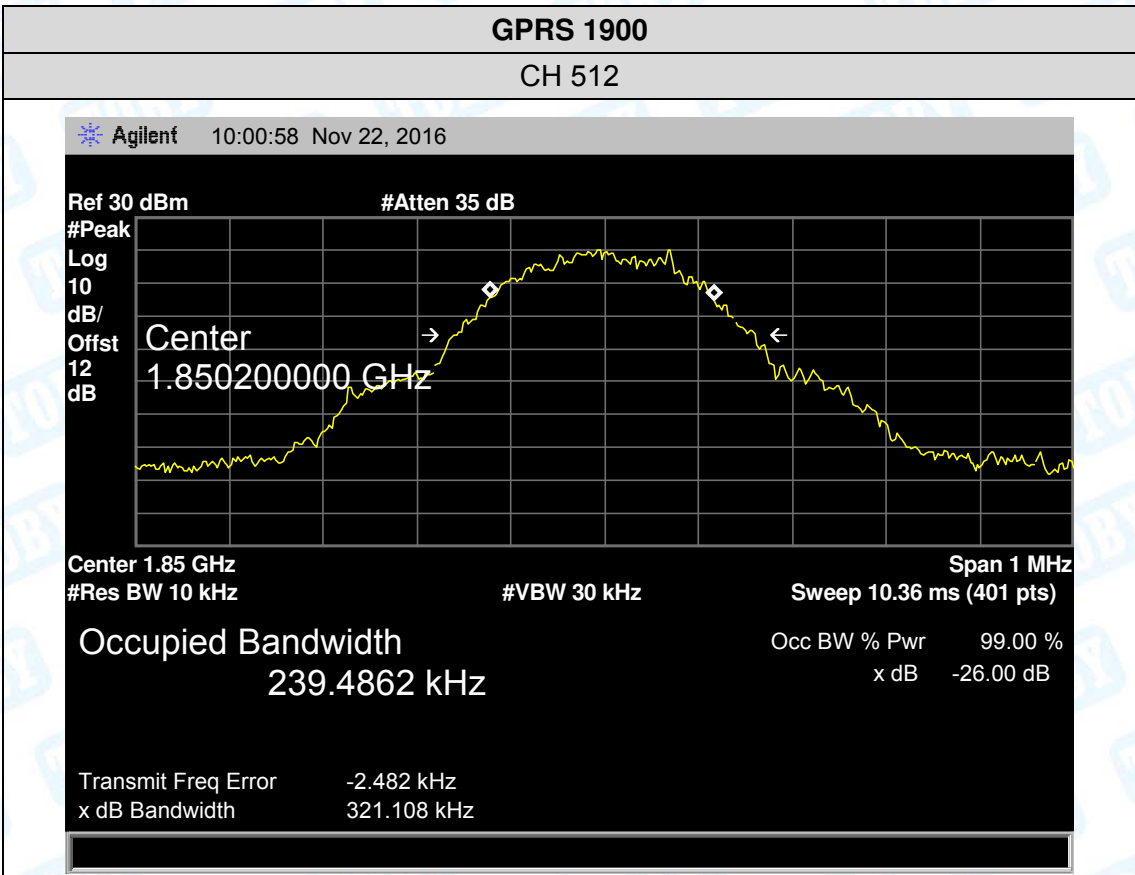

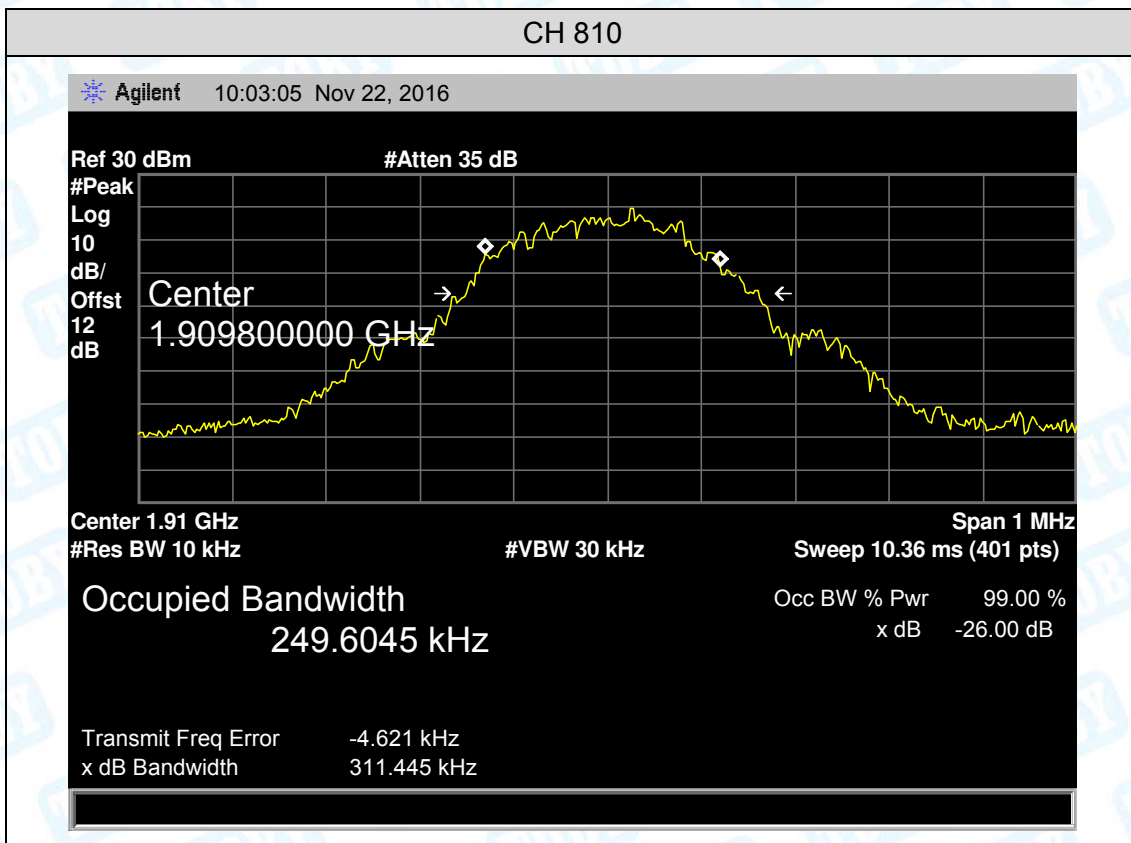

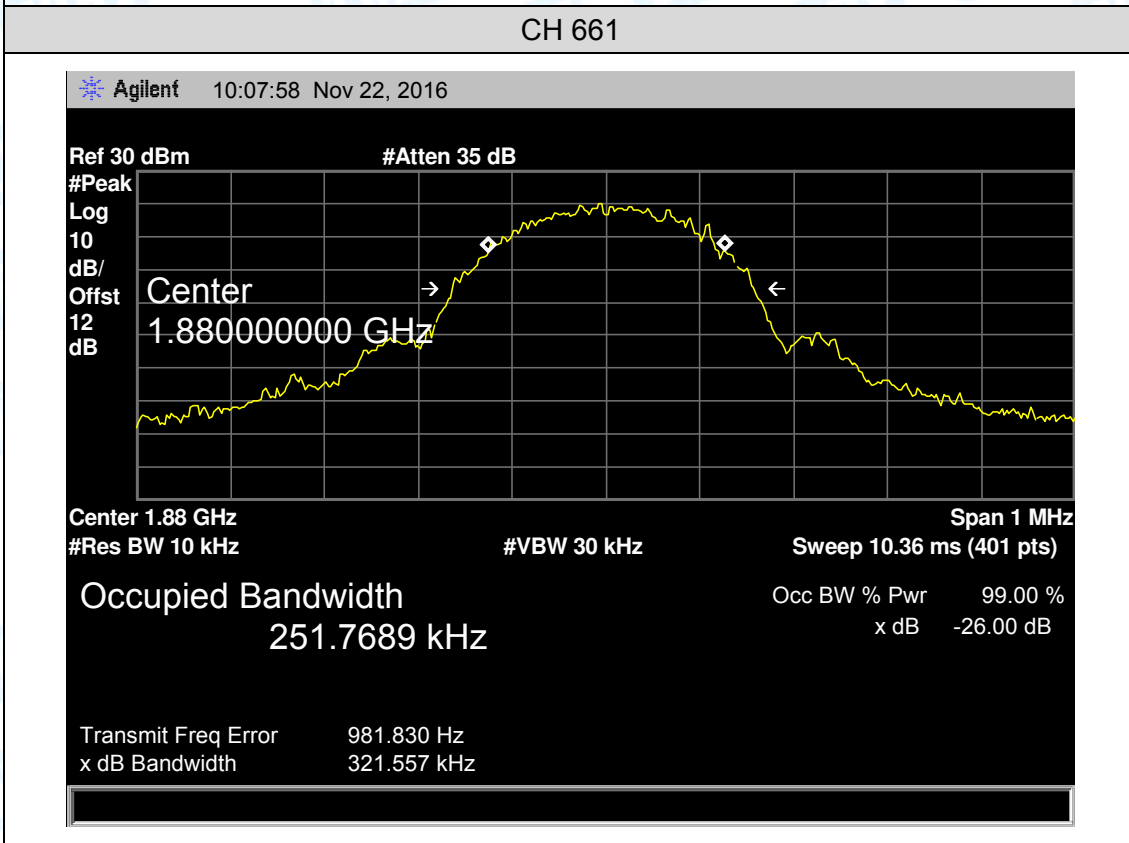
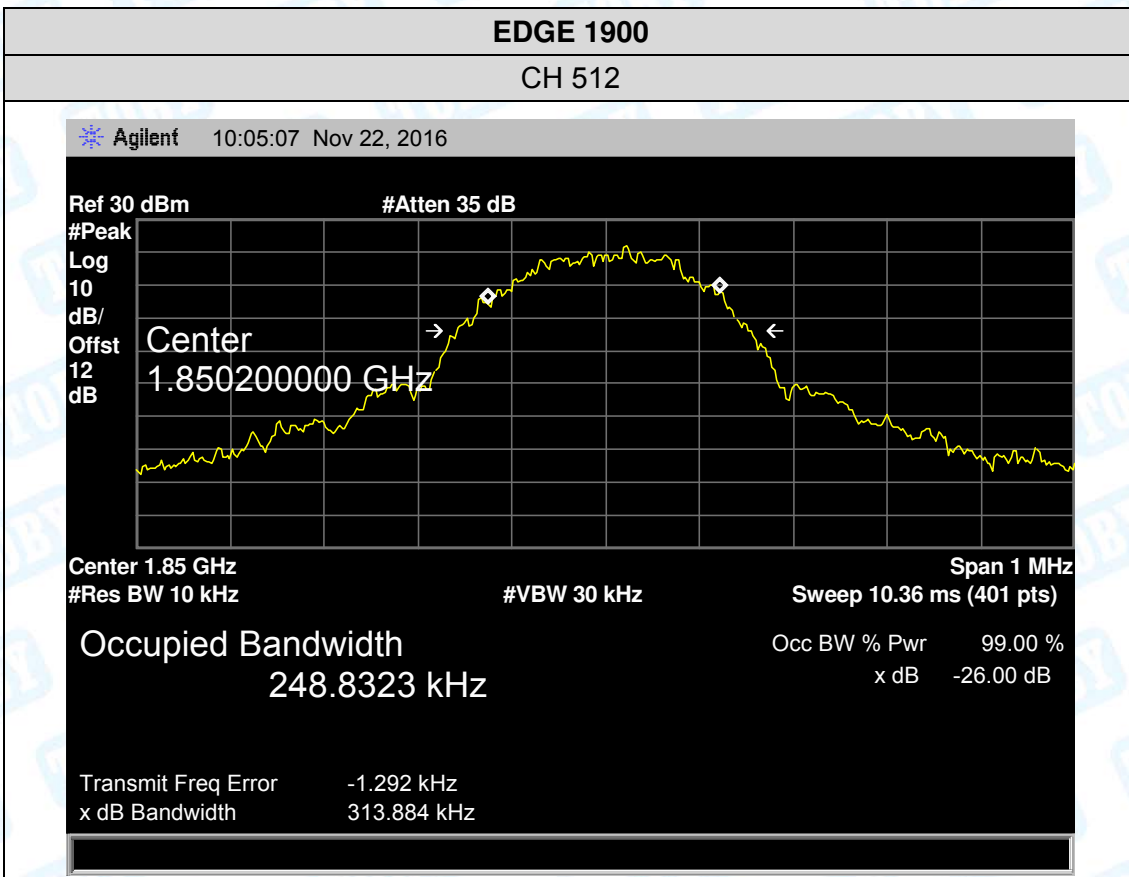

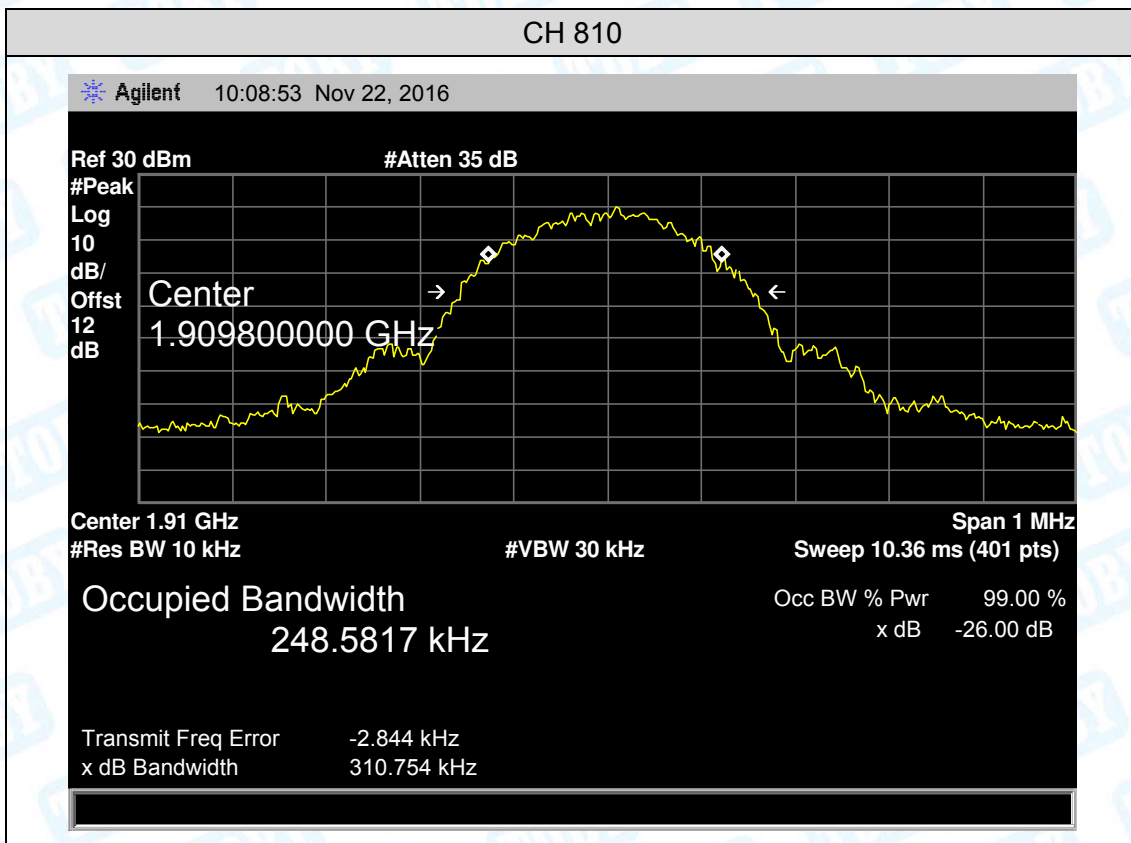

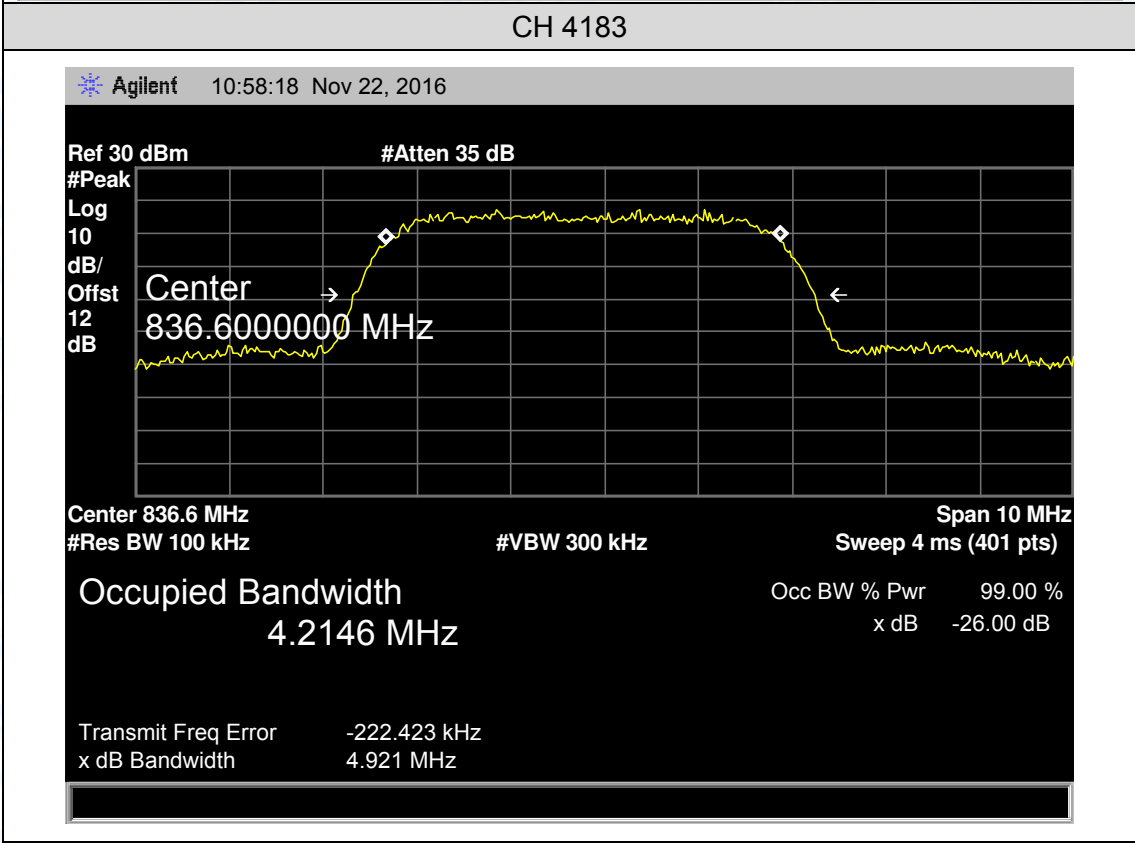
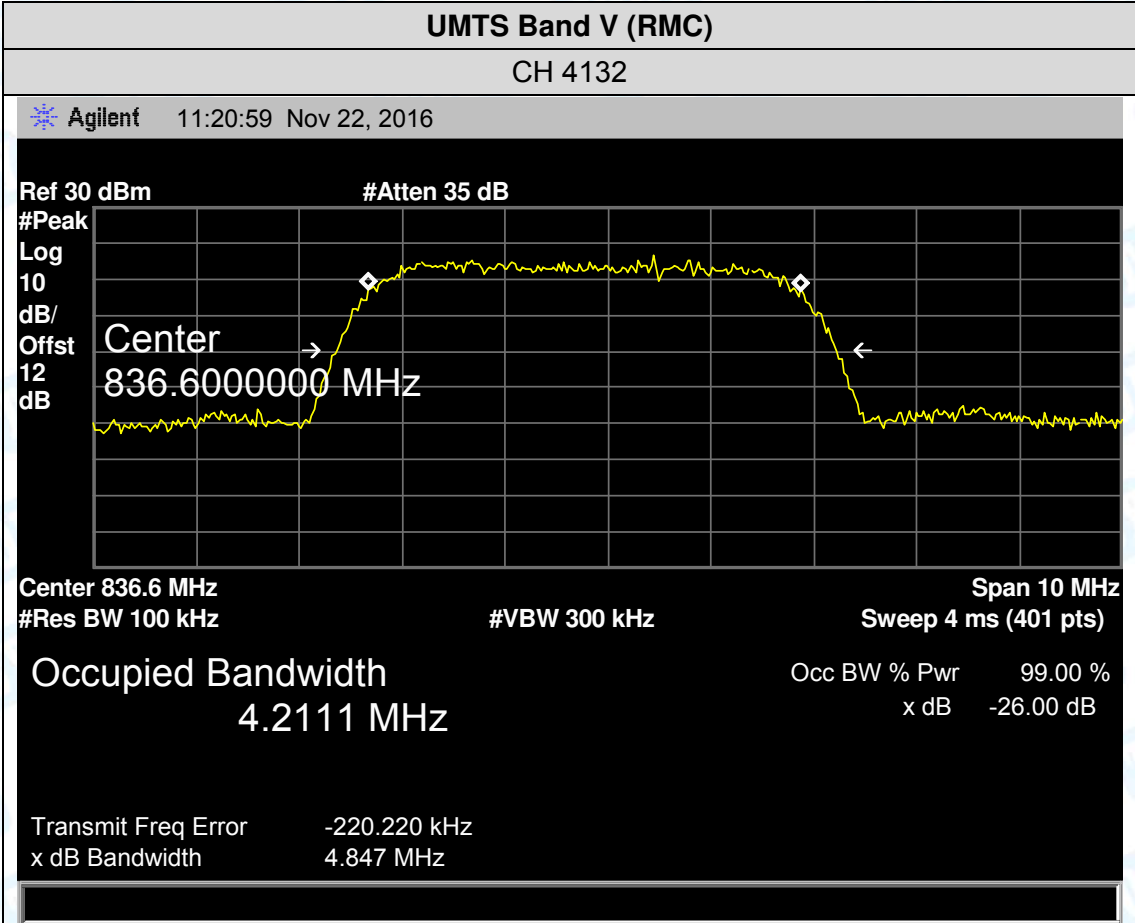

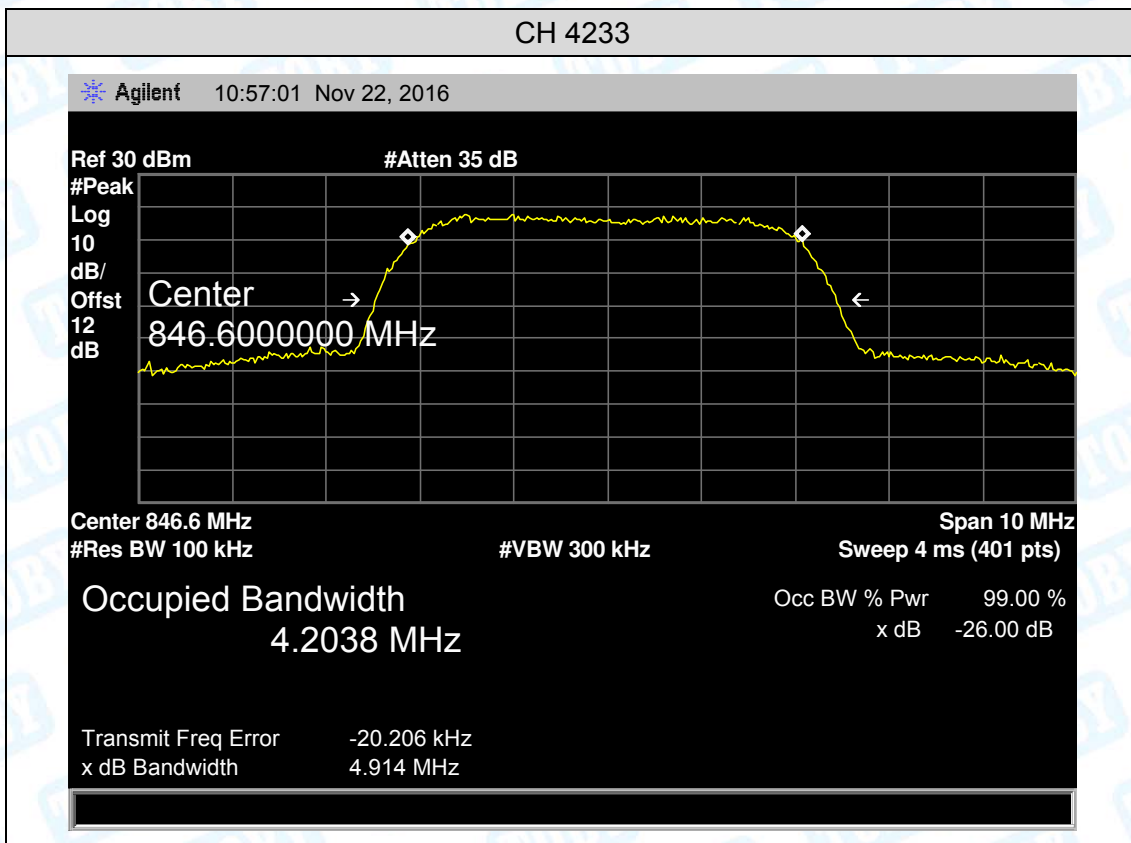

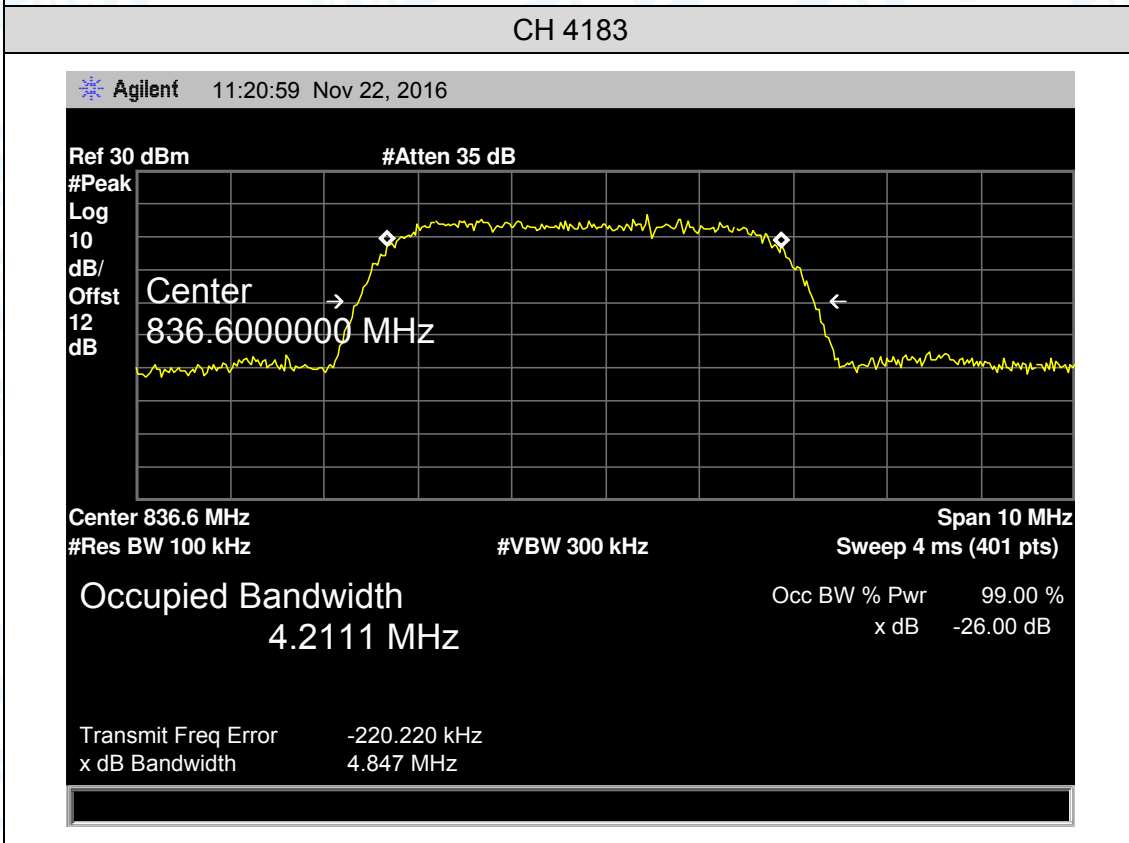
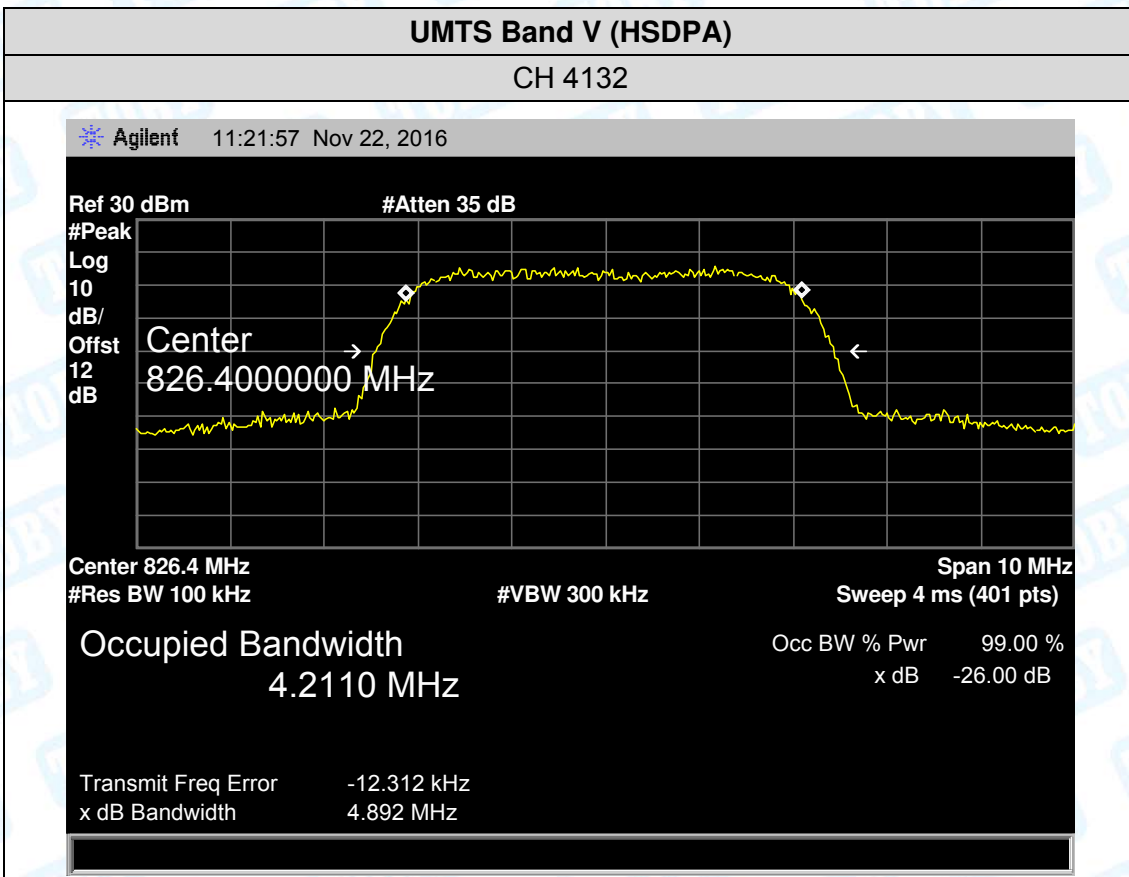



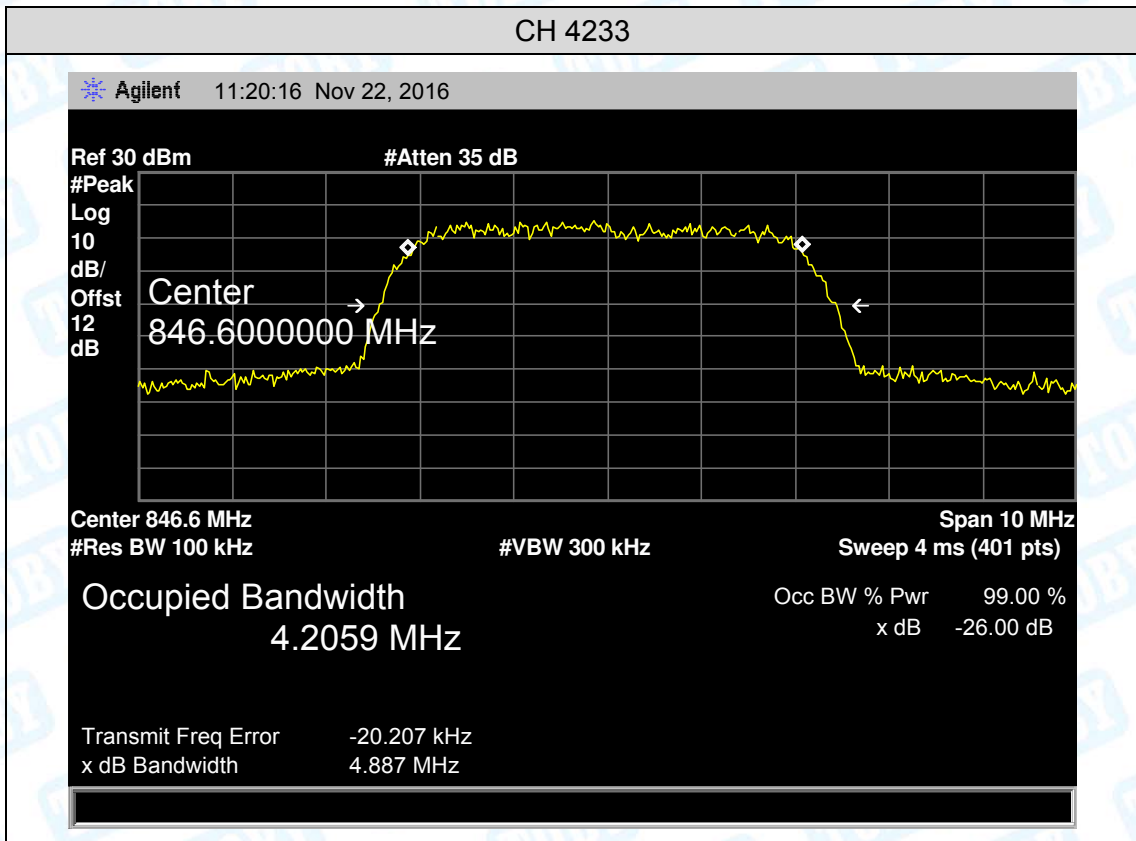

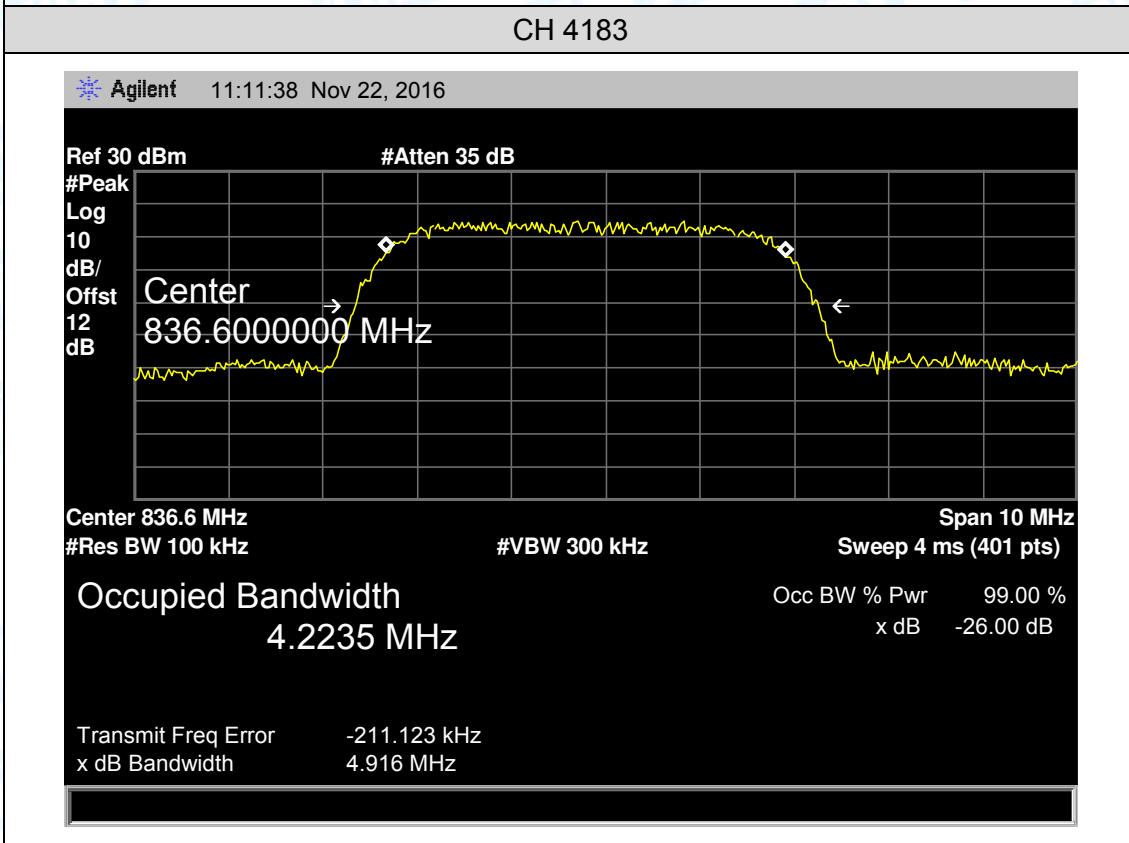
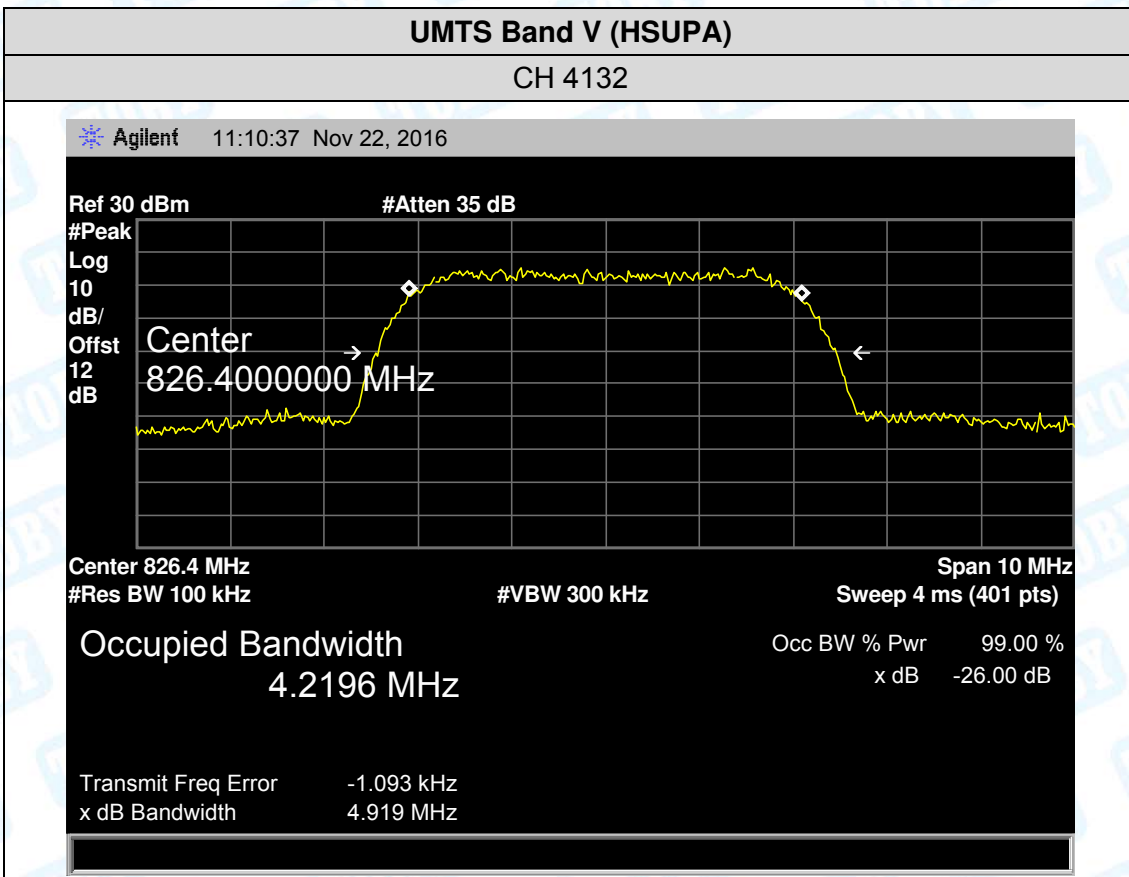

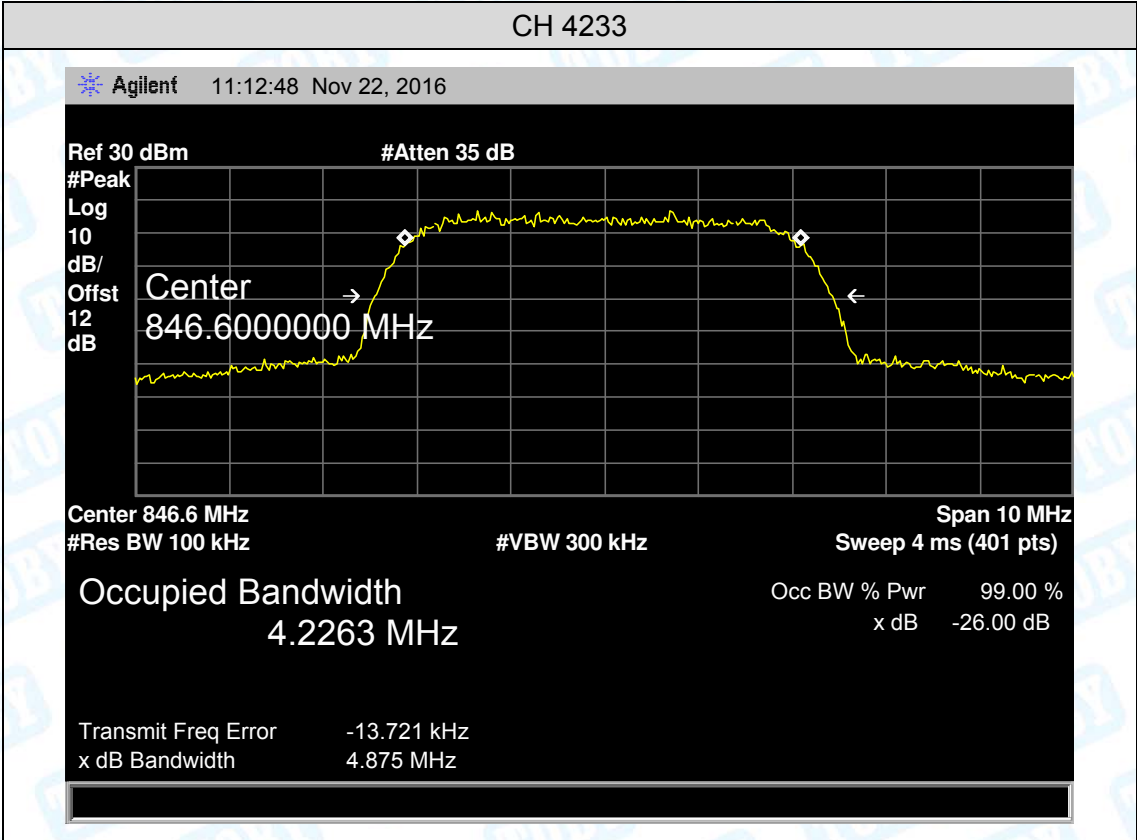

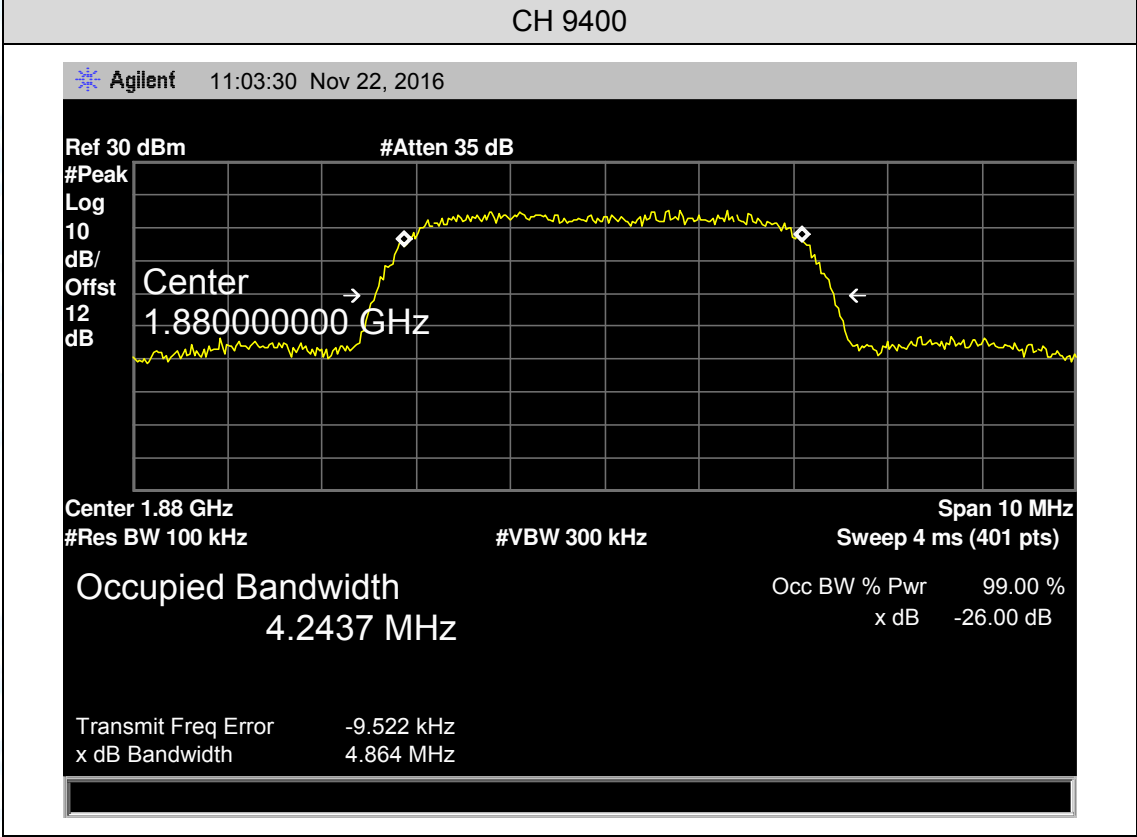
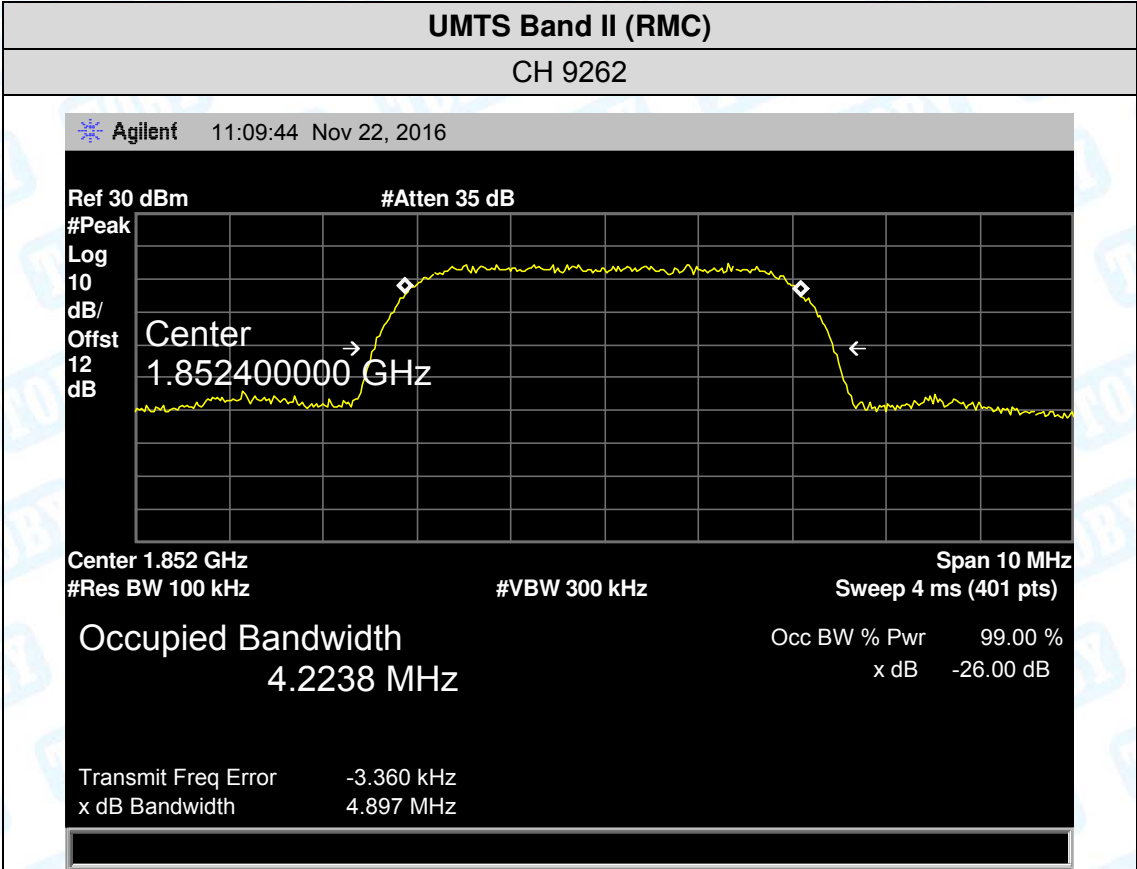

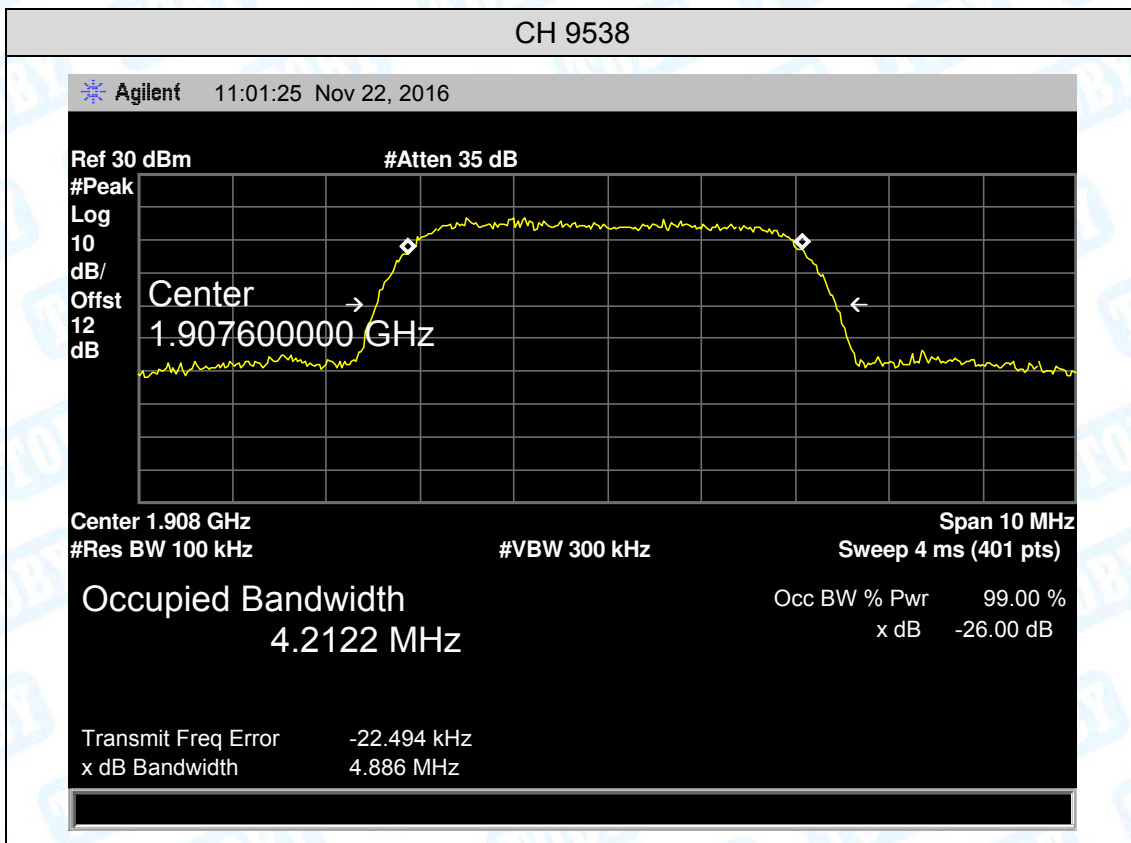

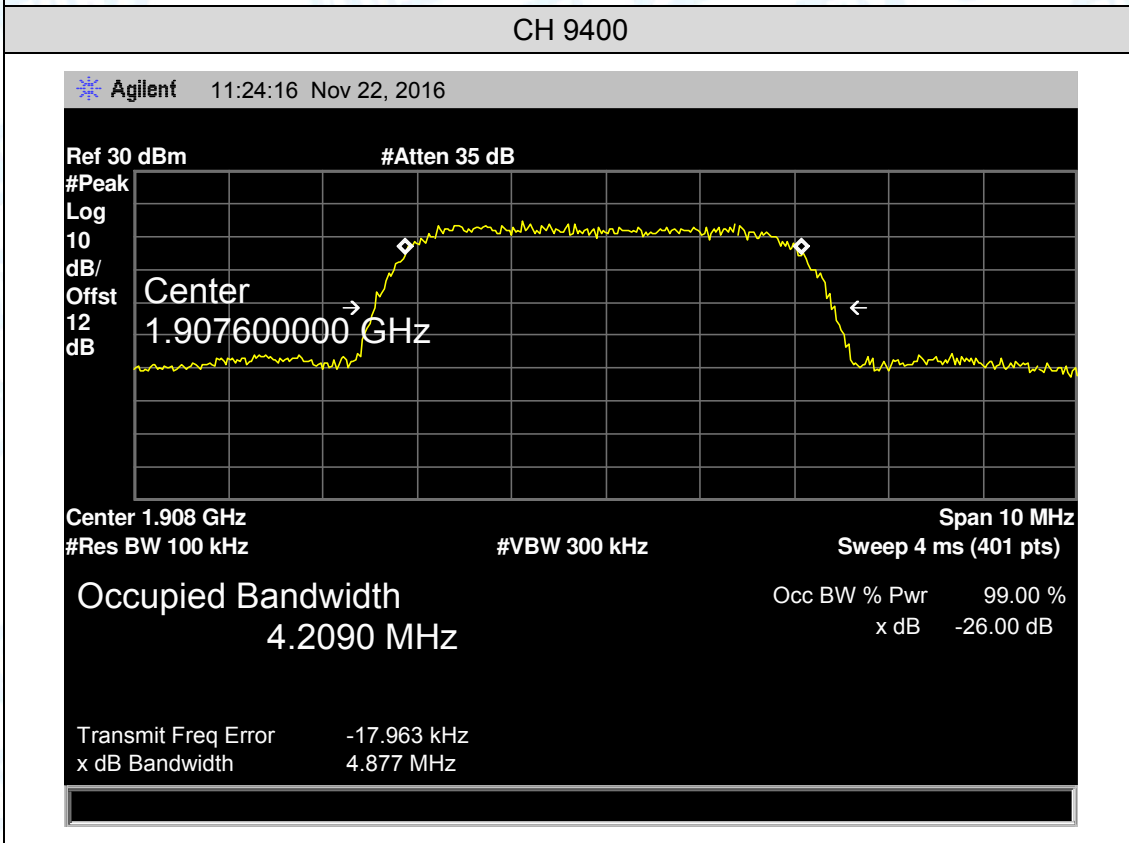
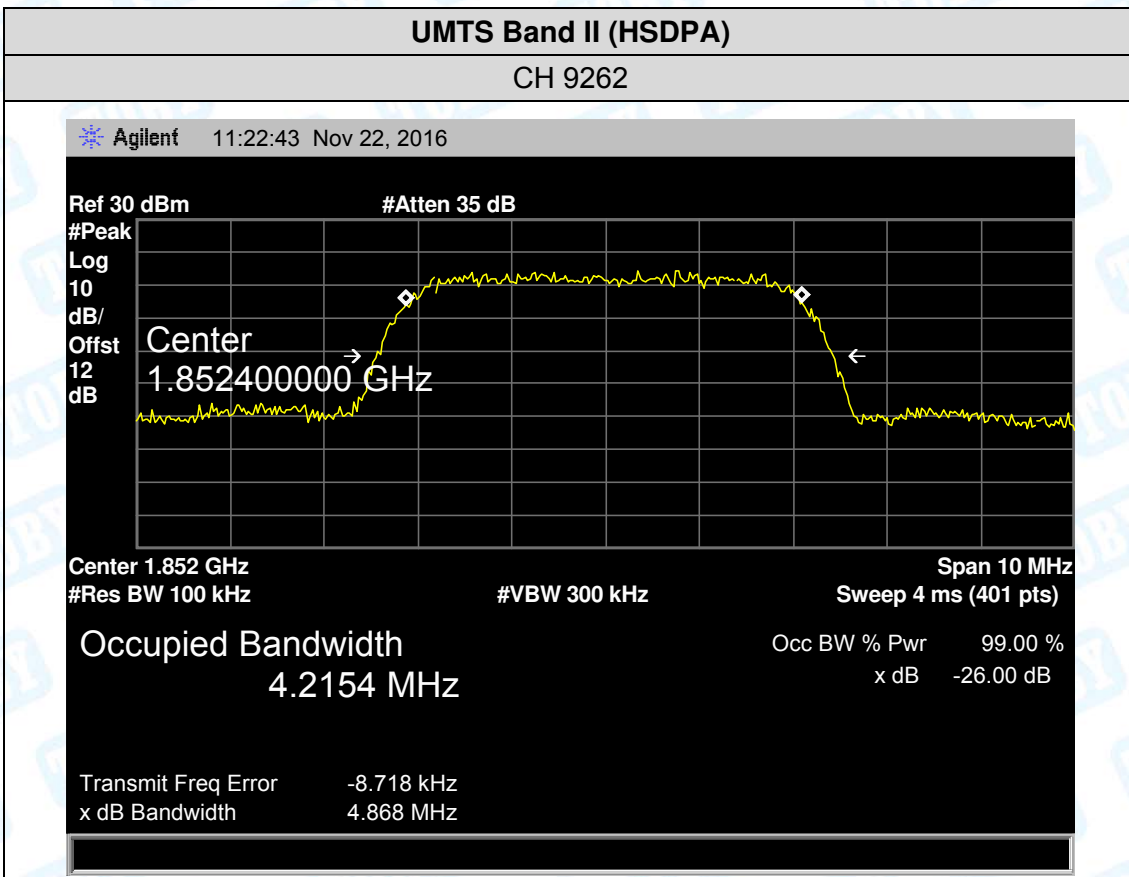

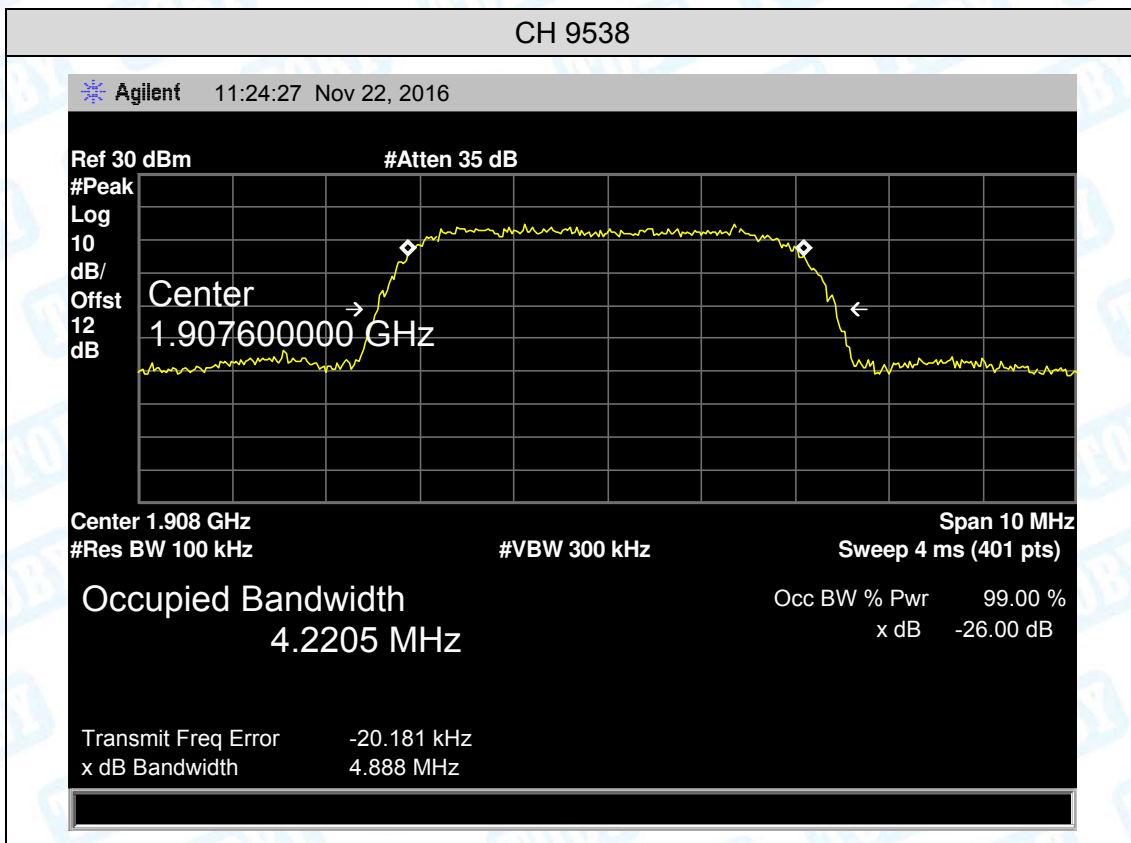

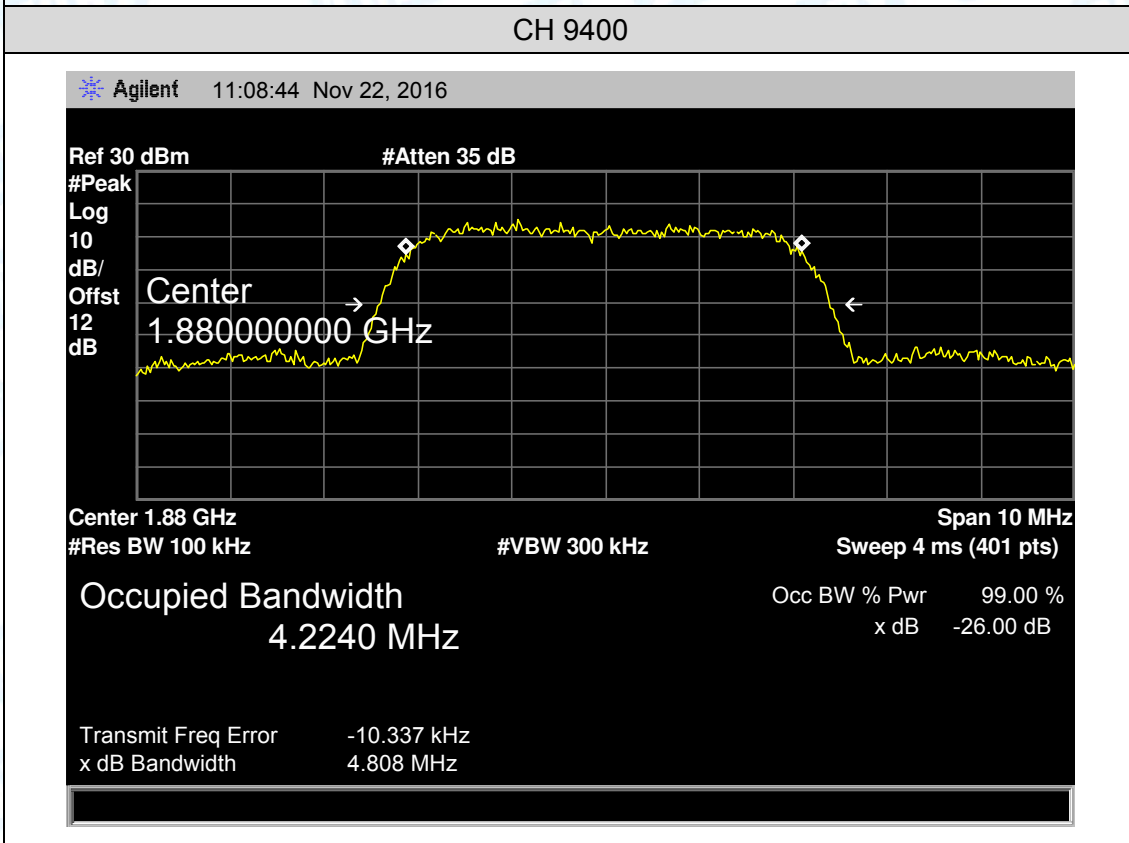
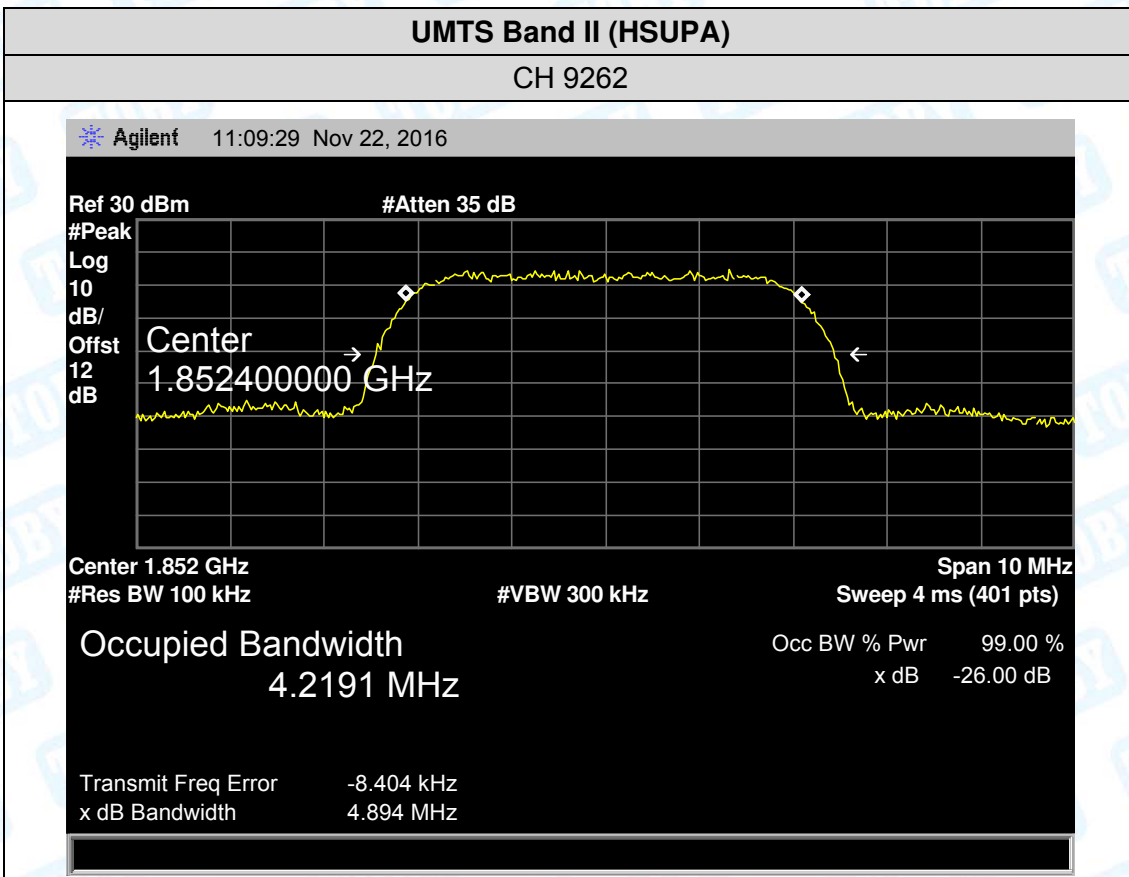



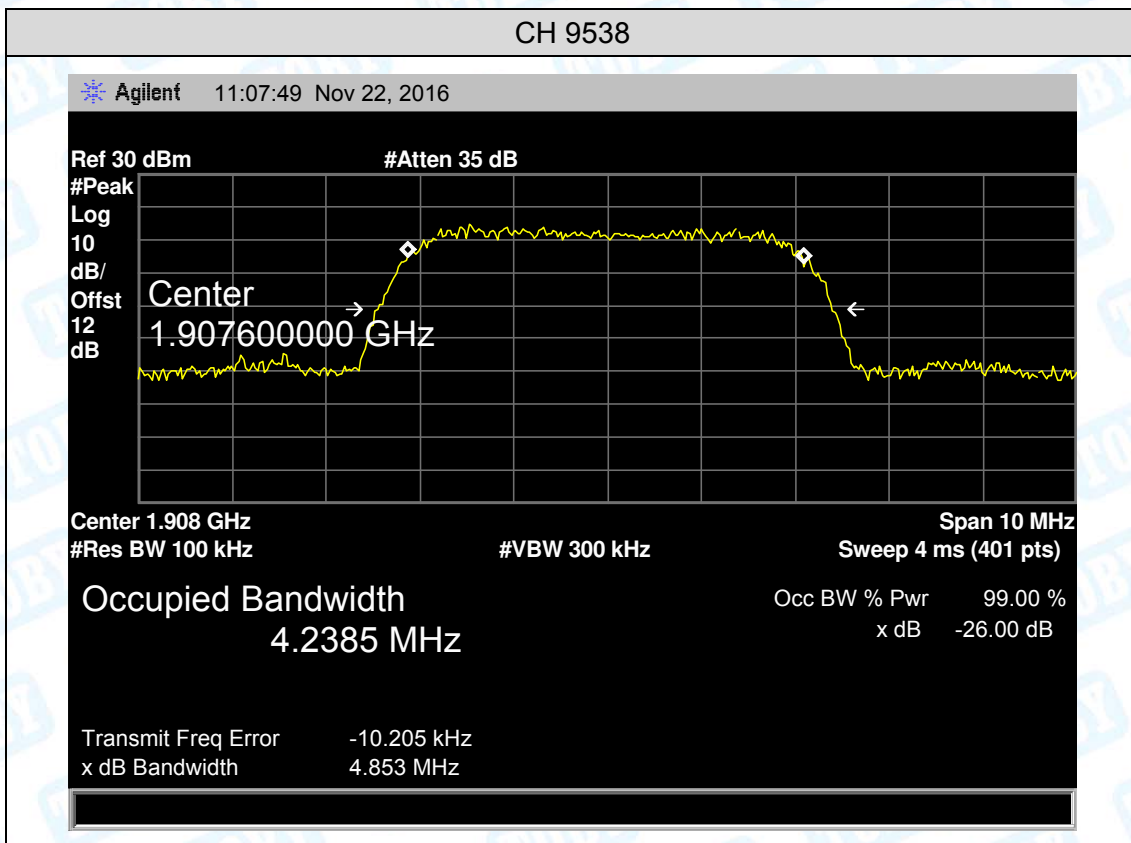

## 9. Conducted Out of Band Emissions

### 9.1 Test Standard and Limit

#### 9.1.1 Test Standard

FCC Part 2: 2.1051, 2.1057

FCC Part 22H: 22.917(a)

FCC Part 24E: 24.238(a)

#### 9.1.2 Test Limit

The power of any emission outside of the authorized operating frequency ranges must be attenuated below the transmitting power(P) by a factor of at least  $43+10\log(P)$  dB. For all power levels +30 dBm to 0 dBm, this becomes a constant specification limit of -13 dBm.

### 9.2 Test Setup

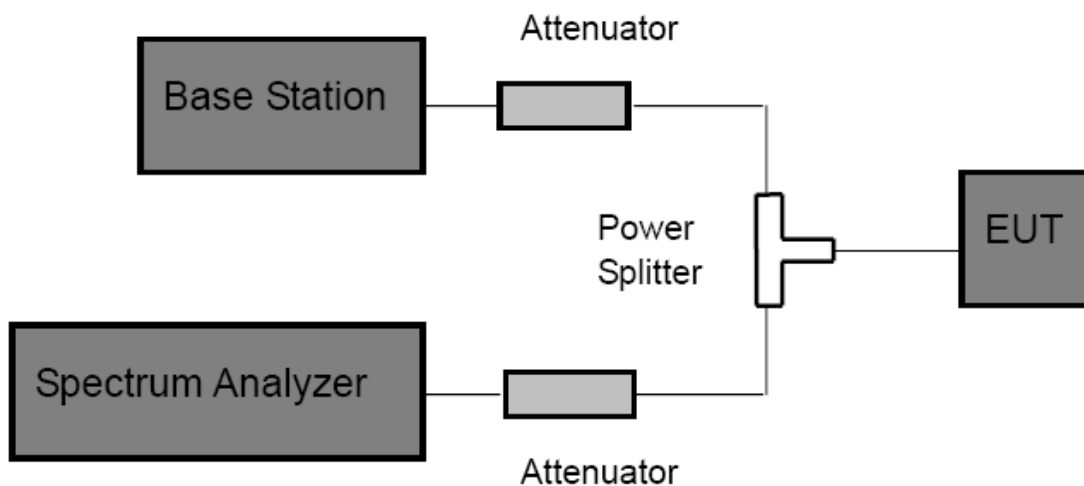

### 9.3 Test Procedure

- (1) The EUT was directly connected to the spectrum analyzer and Base station via power splitter as show in the block diagram above.
- (2) Spectrum Setting:  
 Frequency bellow 1 GHz: RBW=100 kHz, VBW=300 kHz.  
 Frequency above 1 GHz: RBW=1 MHz, VBW=3 MHz.
- (3) The low, middle and high channels of each band and mode's spurious emissions for 30 MHz to 10<sup>th</sup> Harmonic were measured by Spectrum analyzer.

### 9.4 EUT Operating Condition

The EUT was continuously connected with the Base station and transmitting in the max power during the test.

### 9.5 Test Data

Please refer following plots:

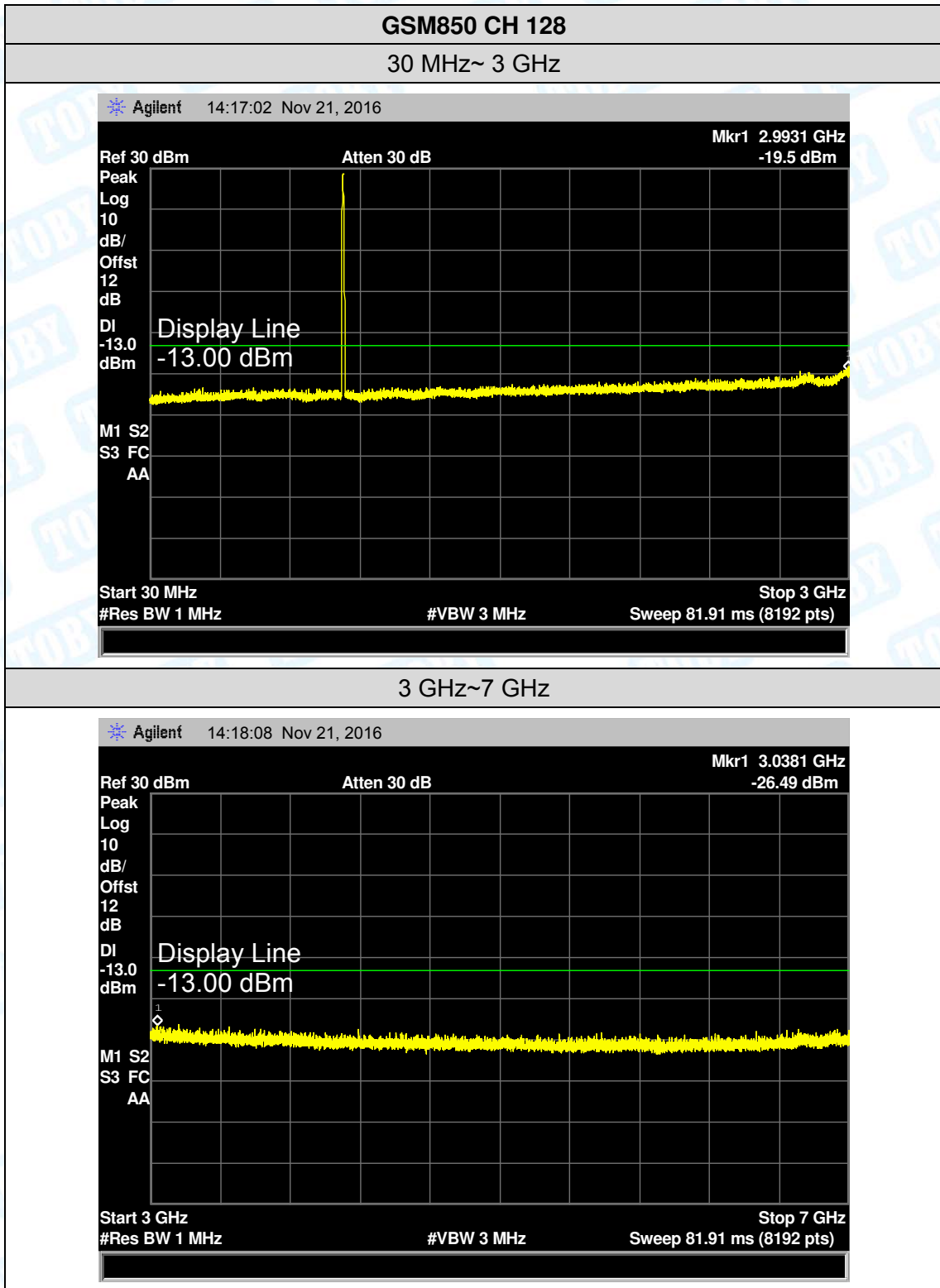

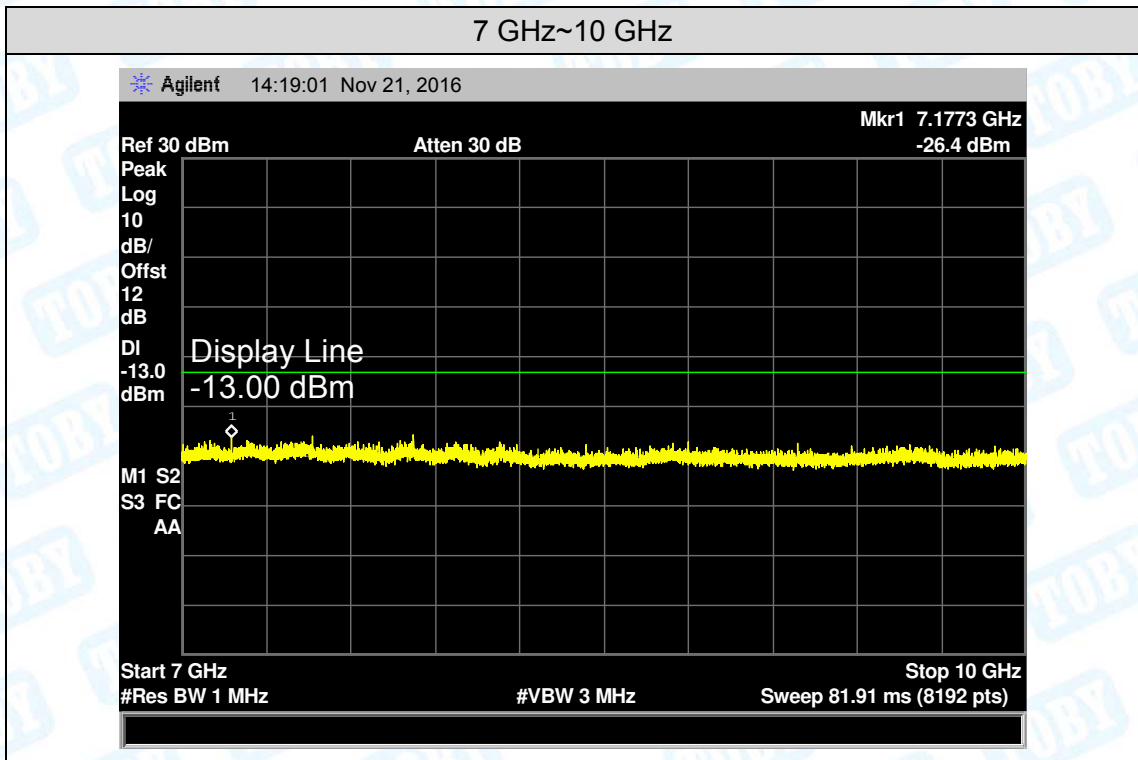

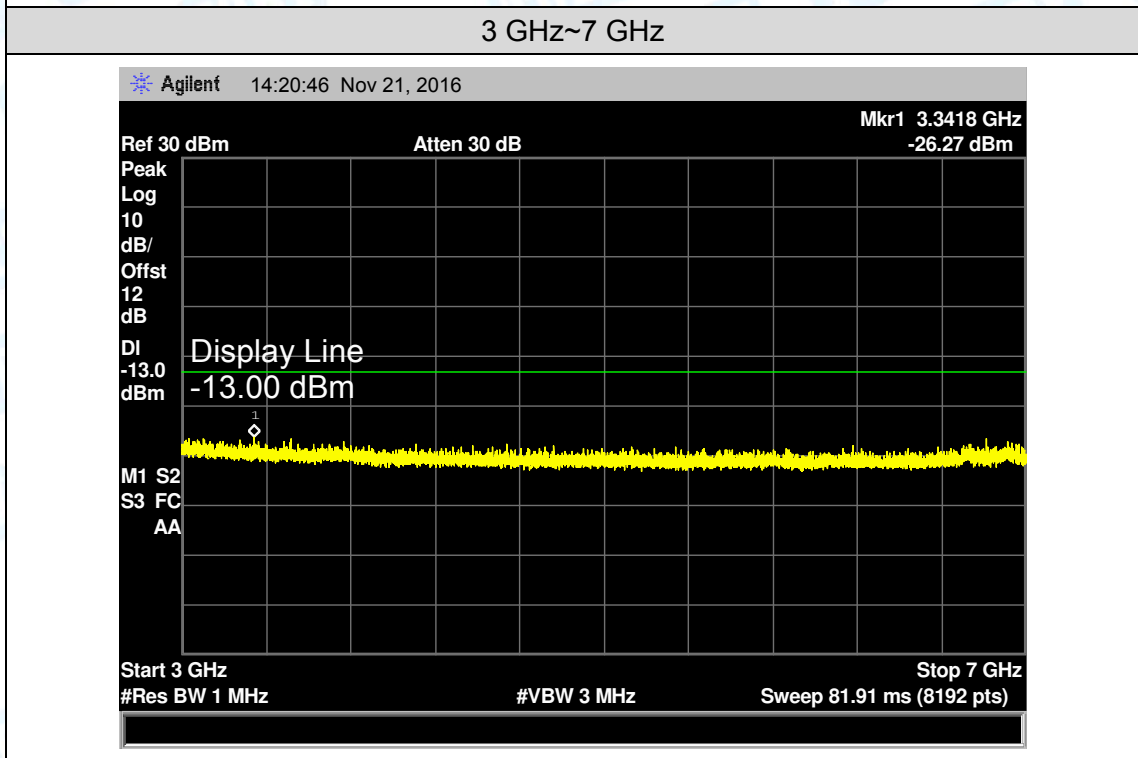
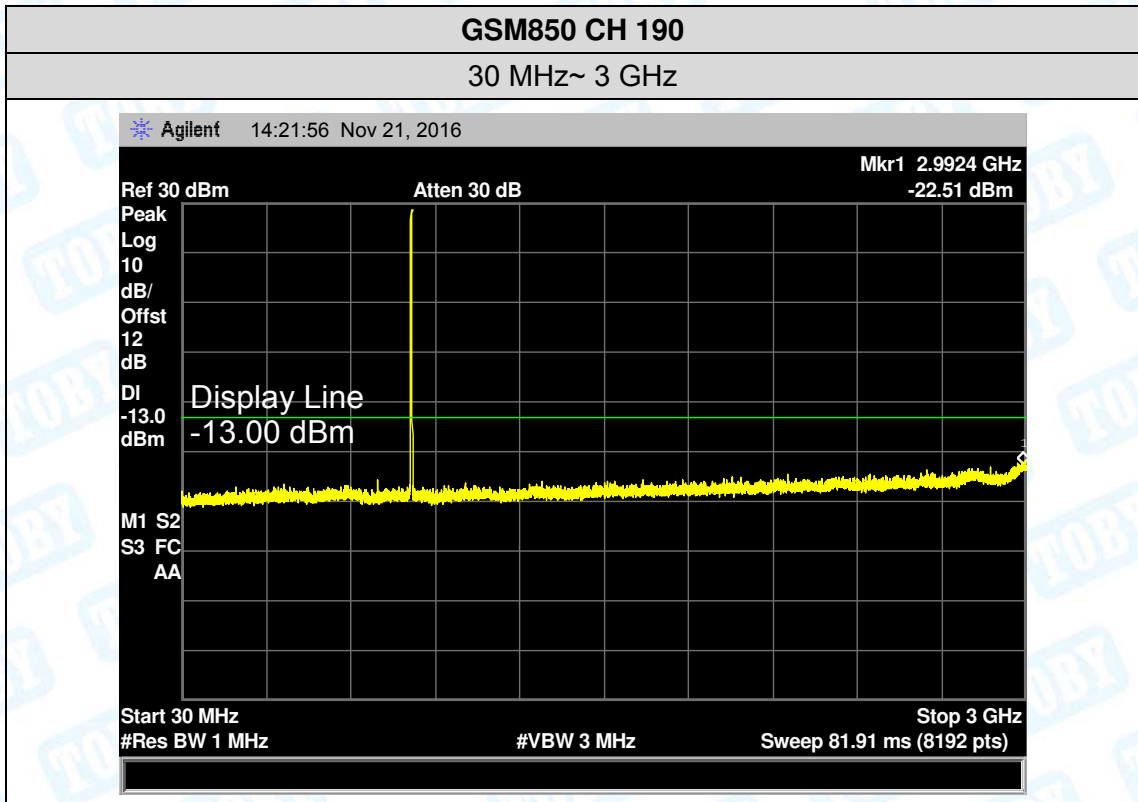

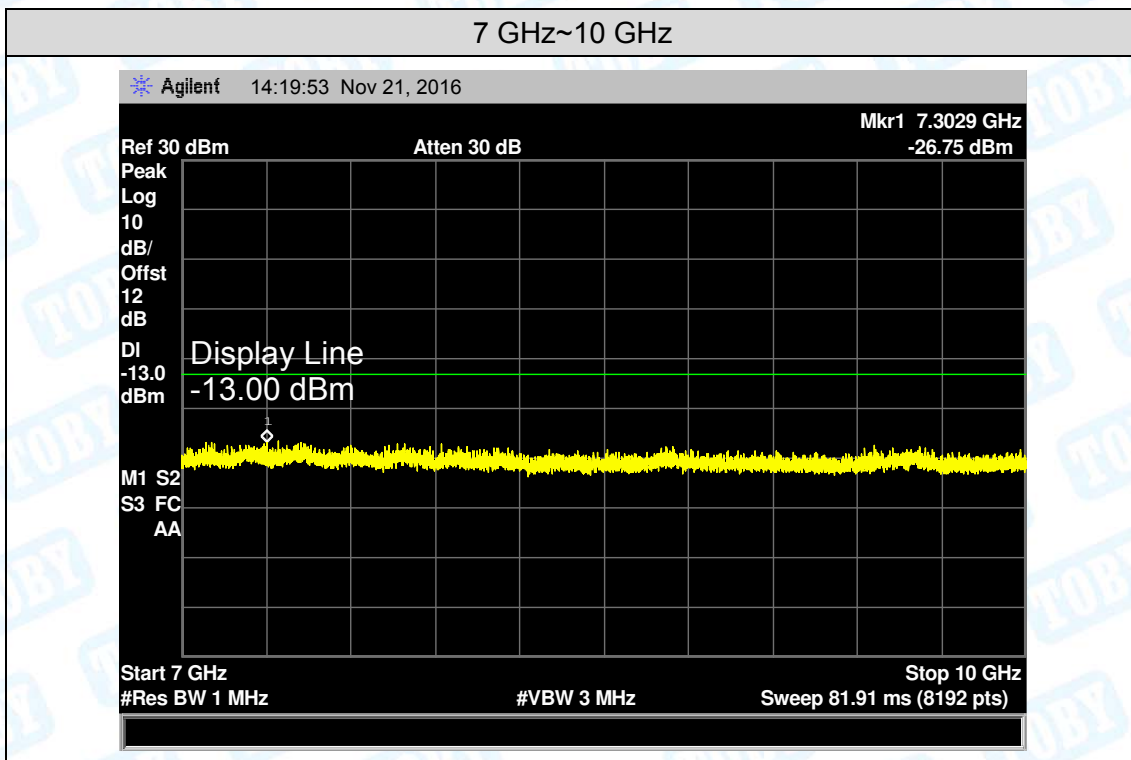

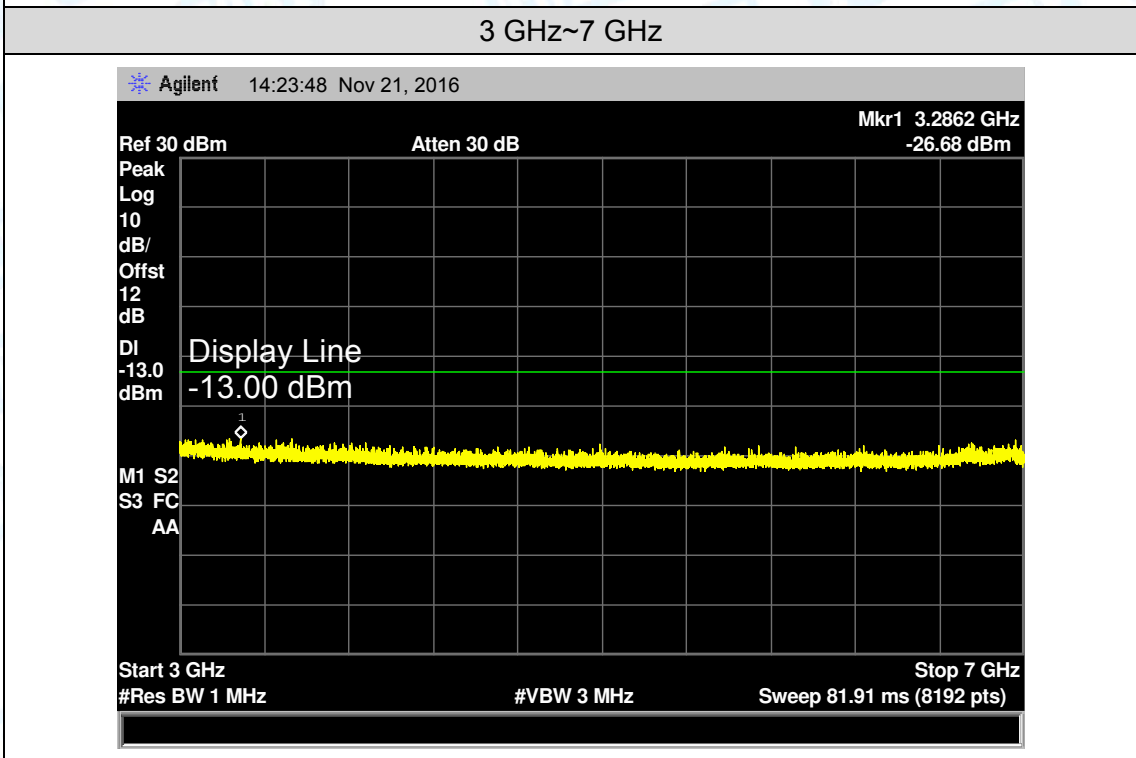
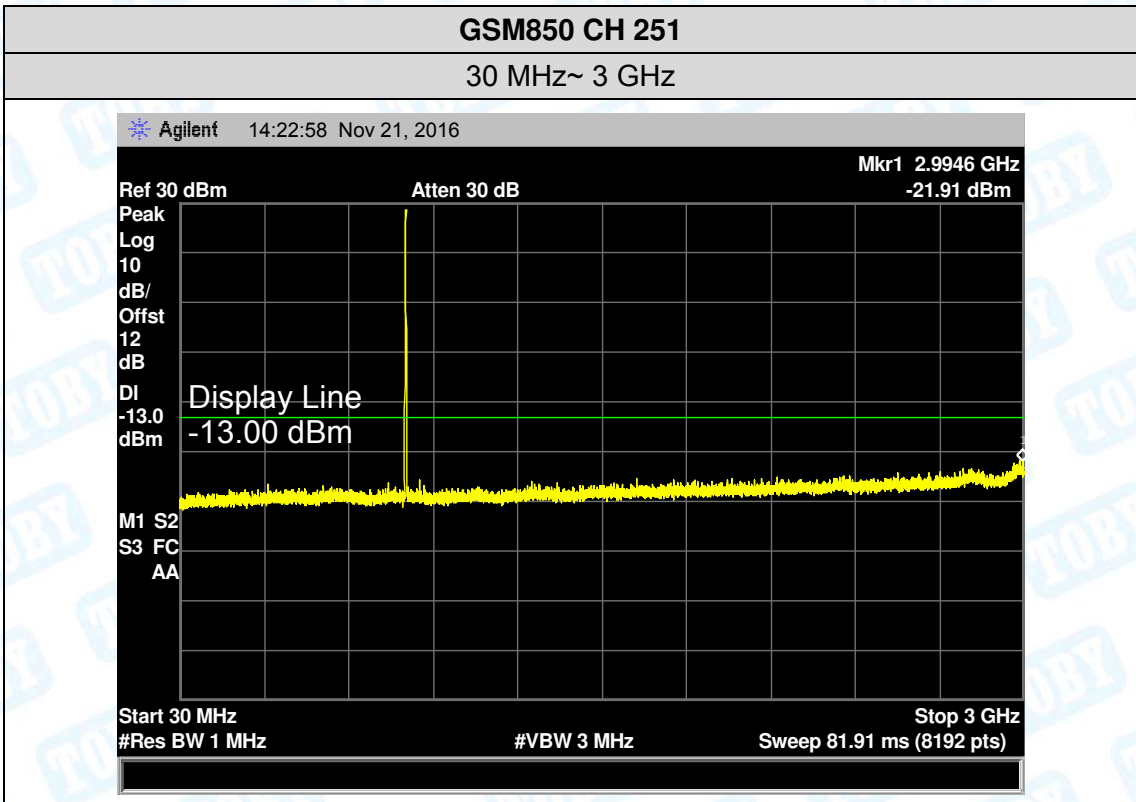

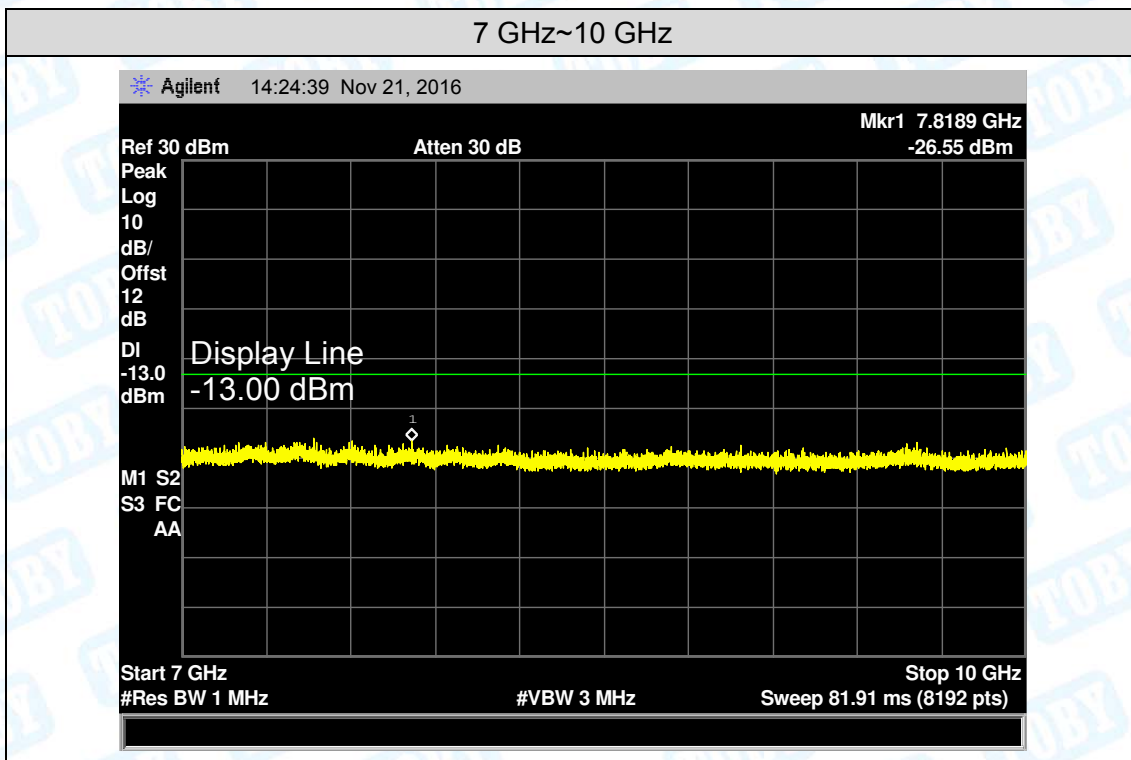



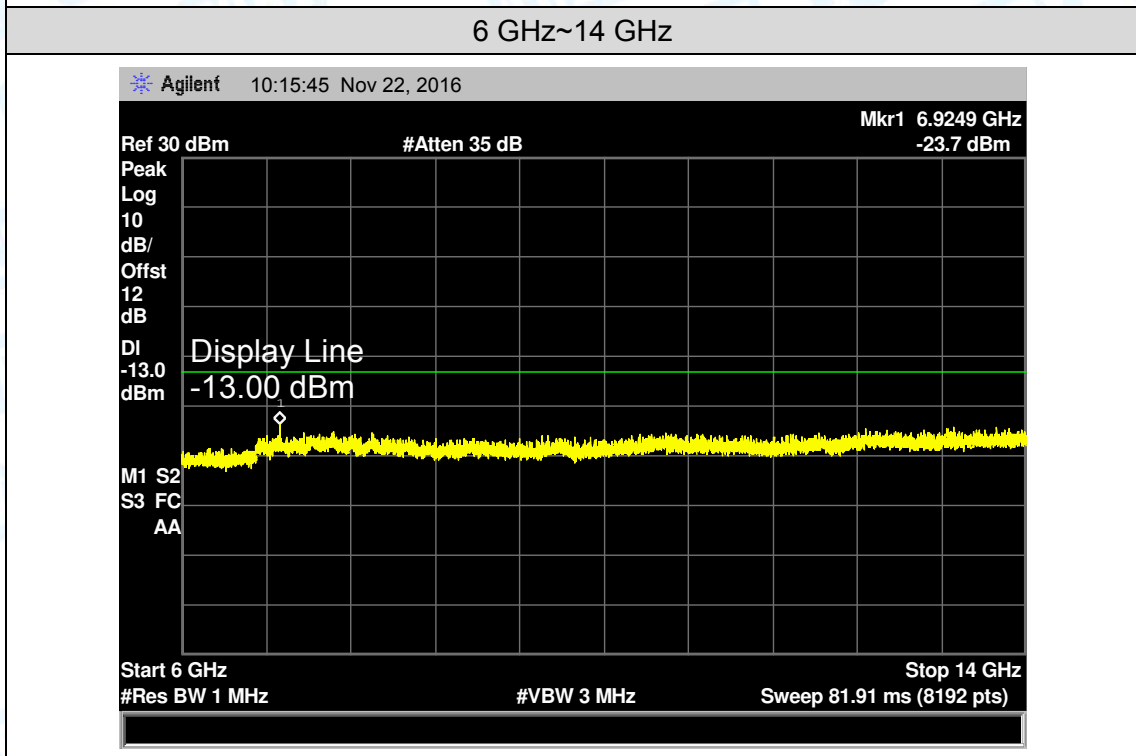
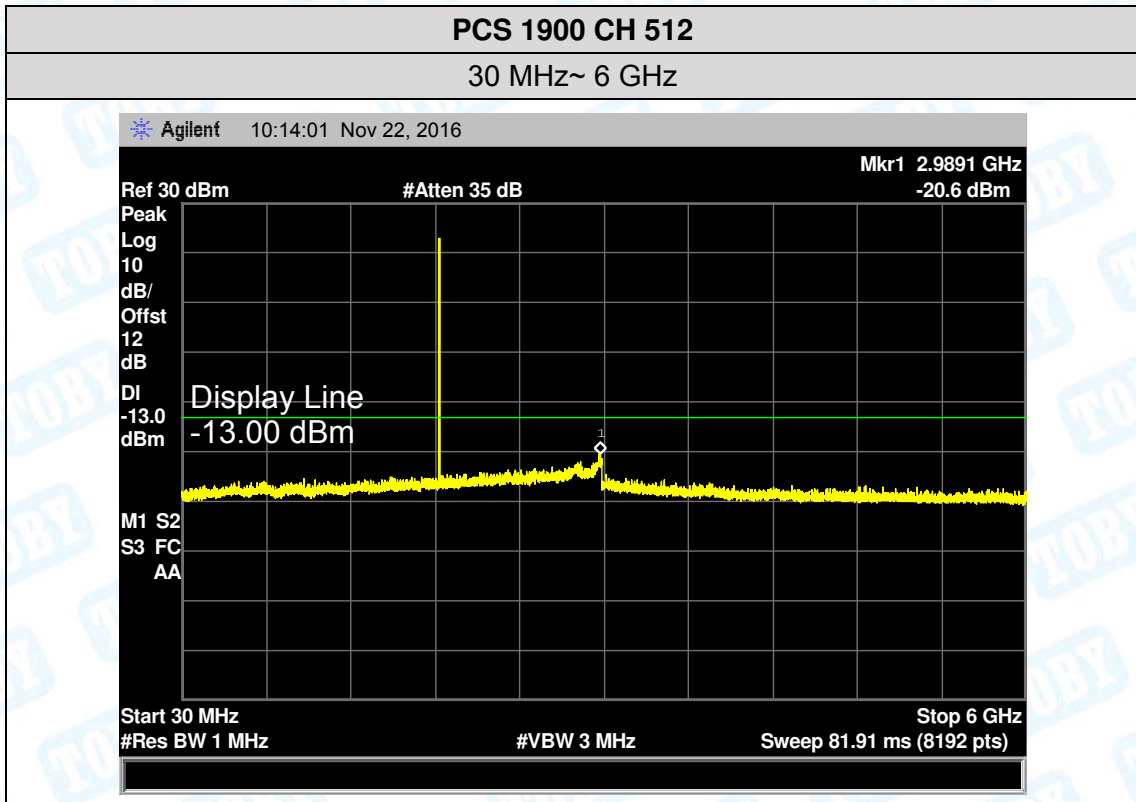

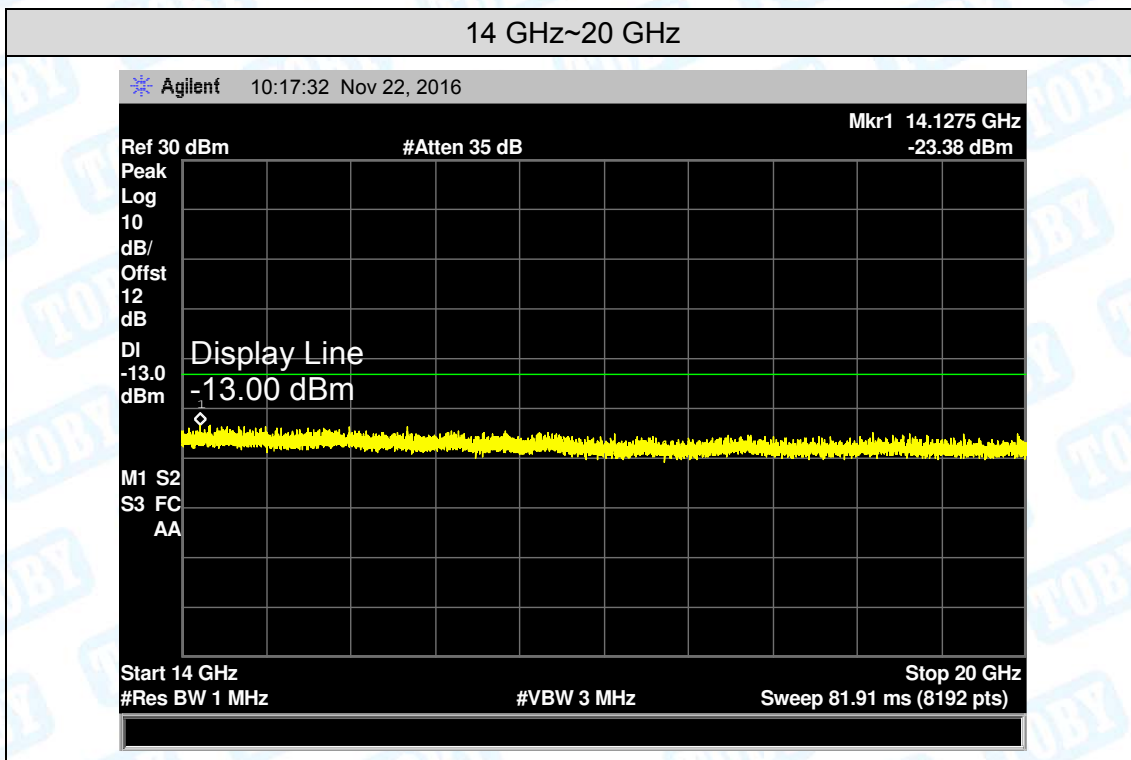

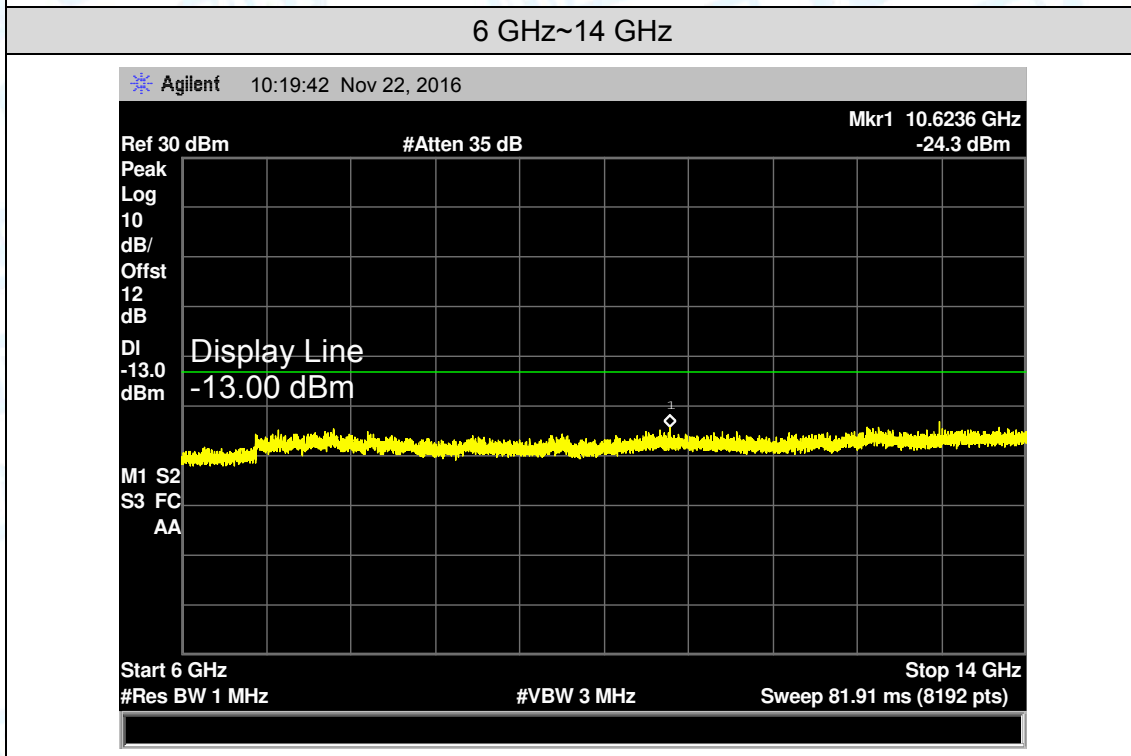
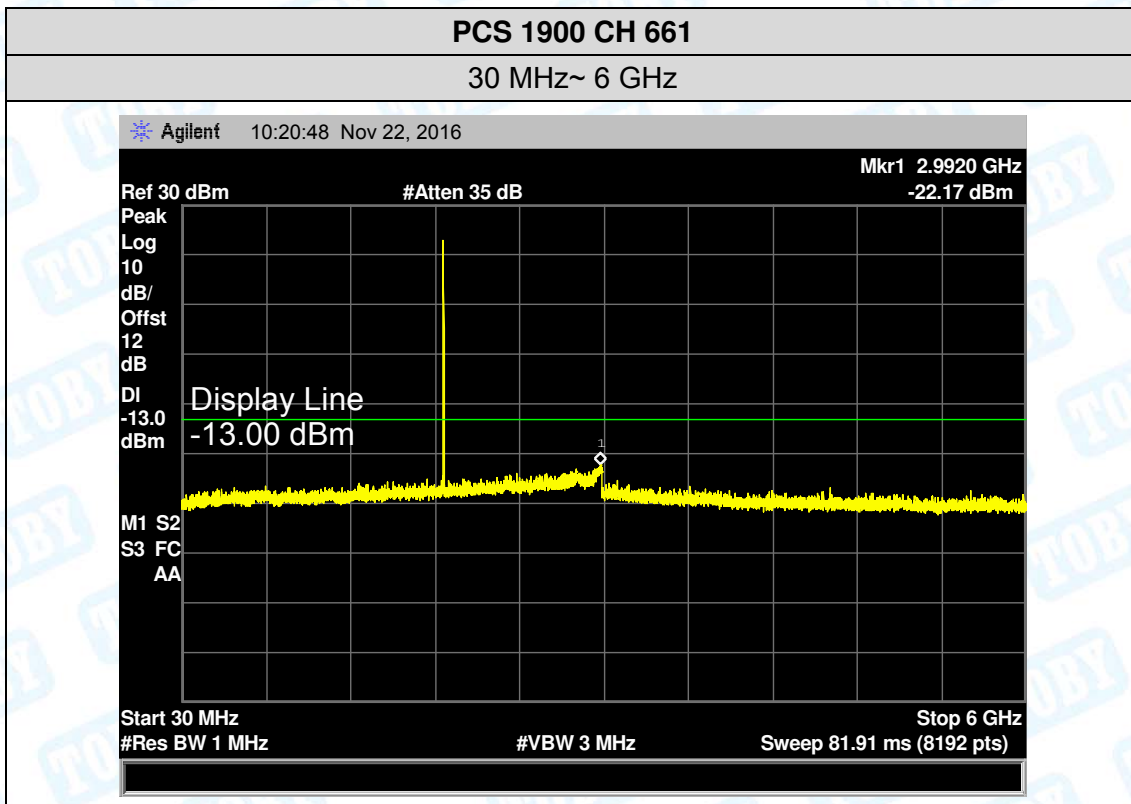

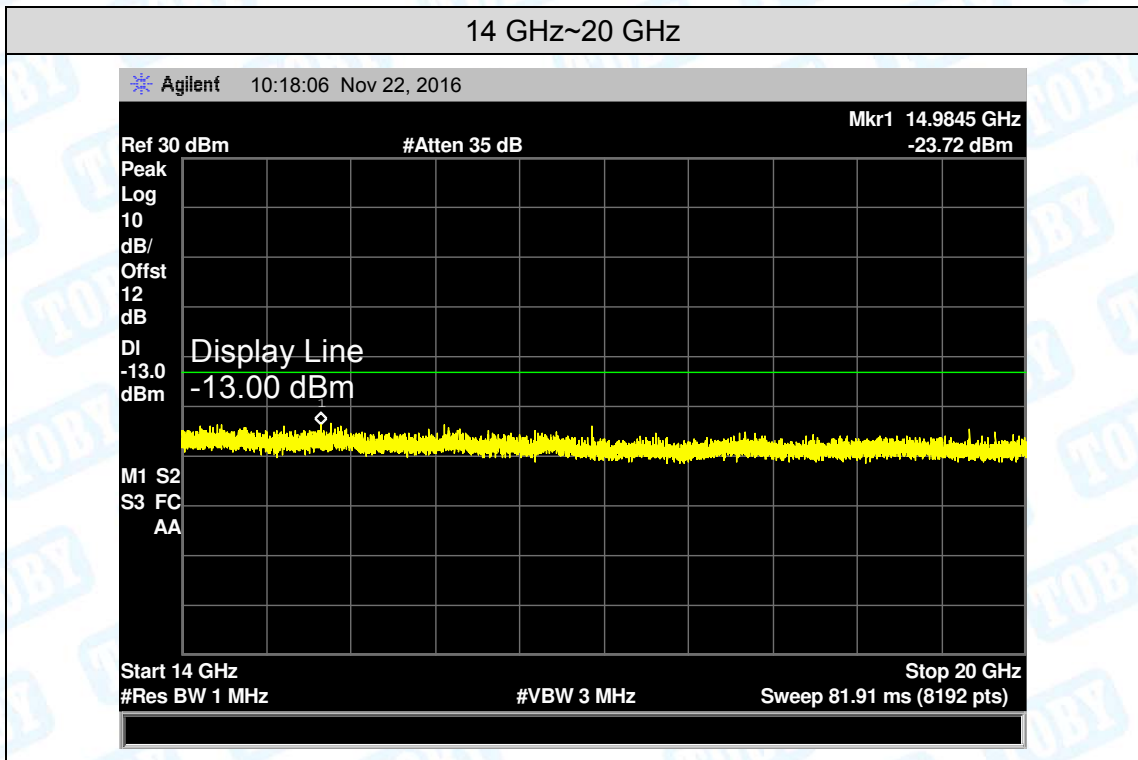

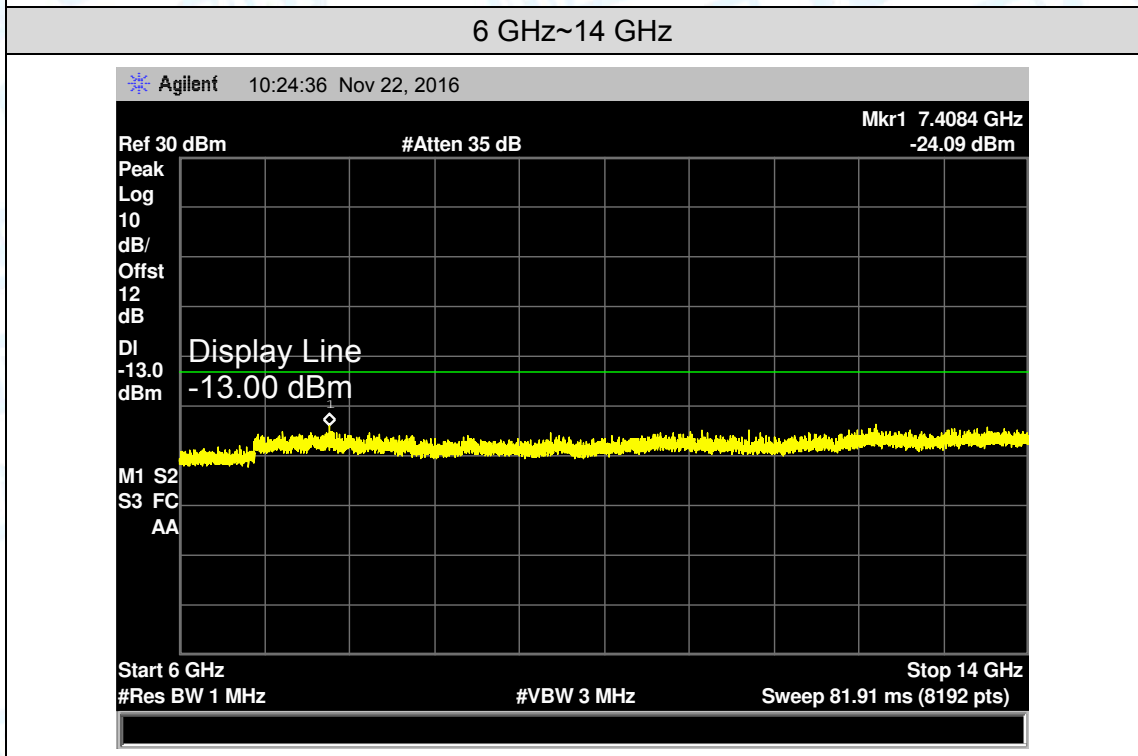
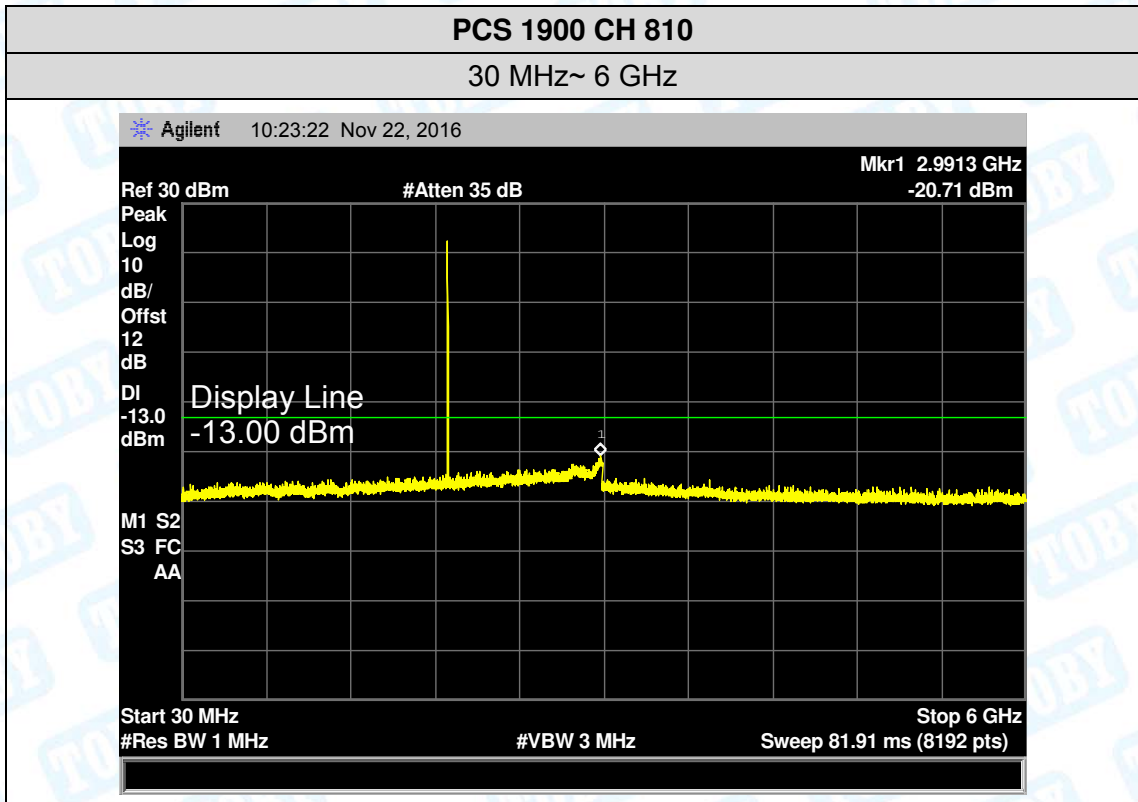

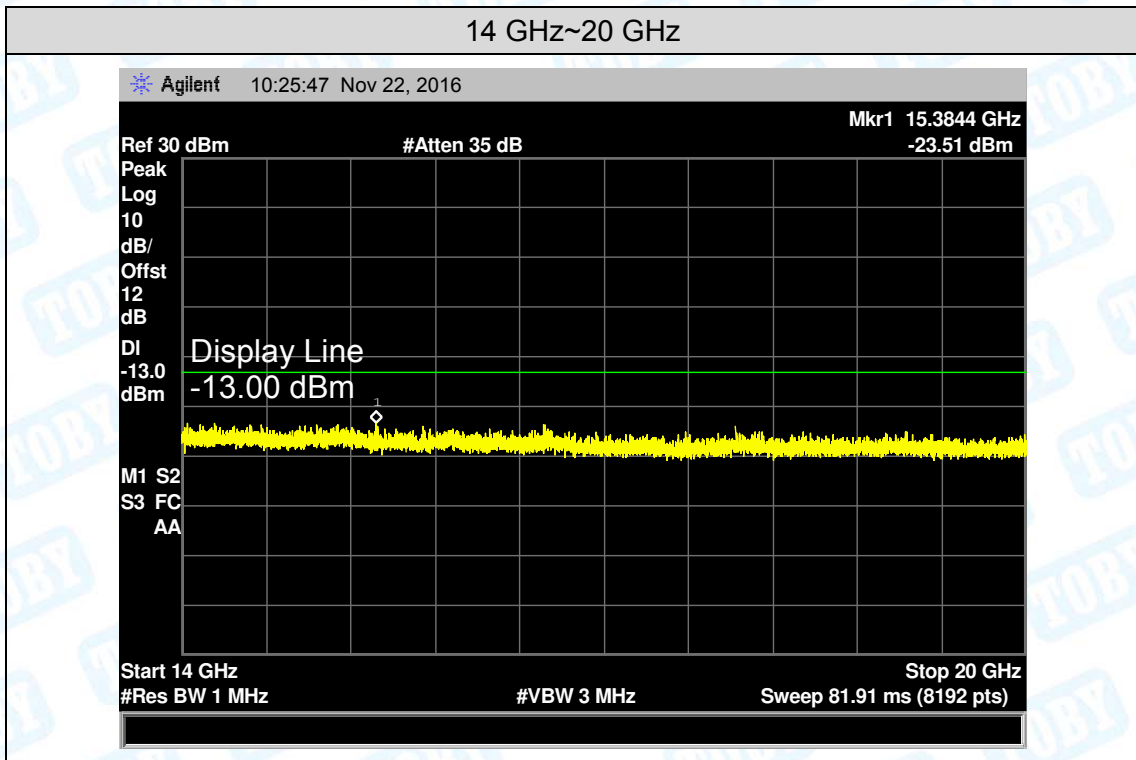

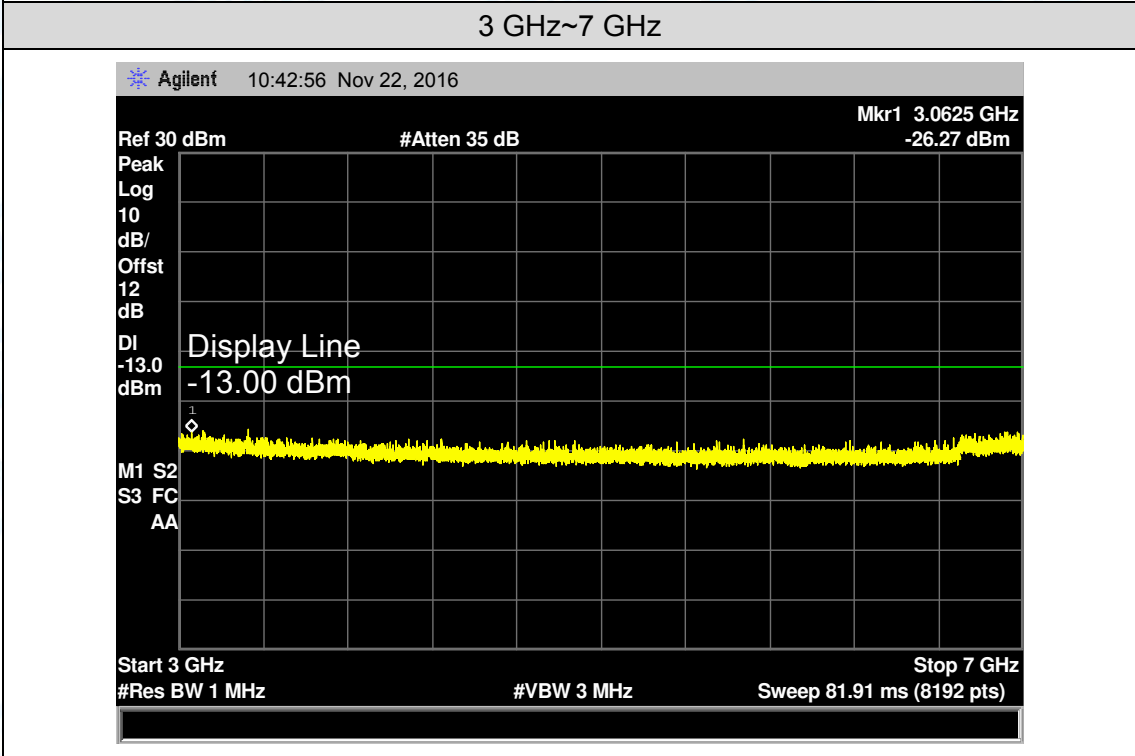
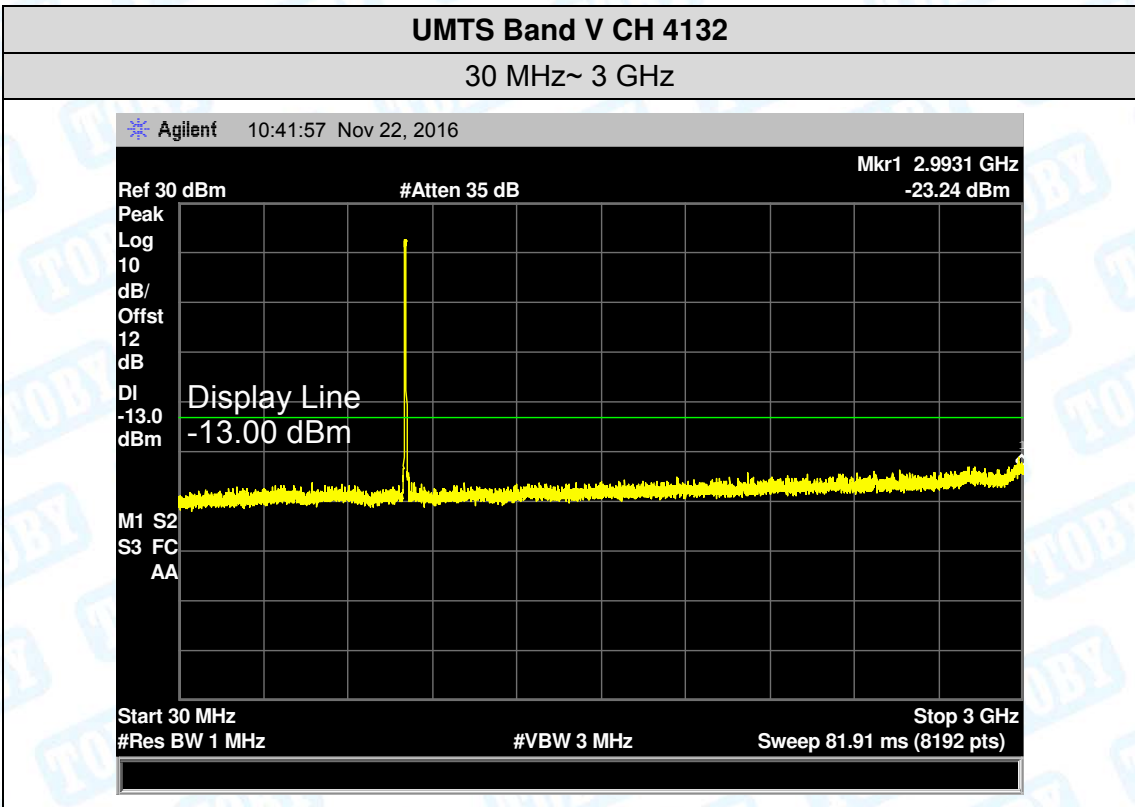

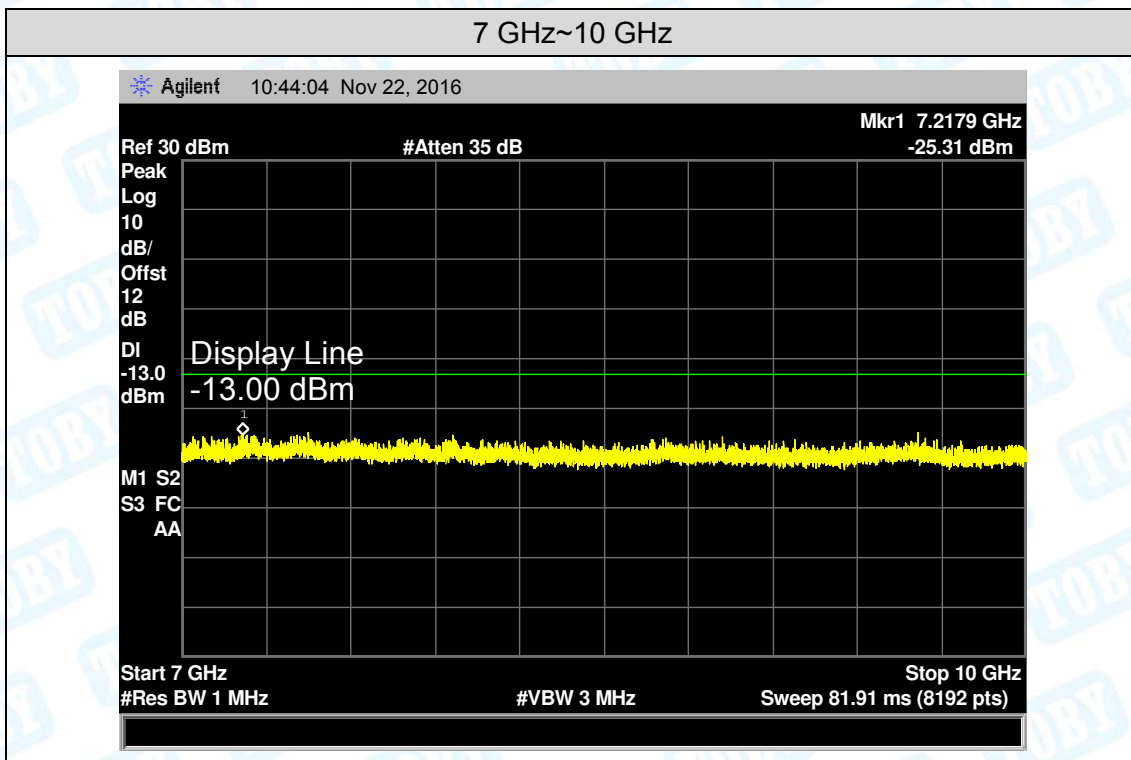



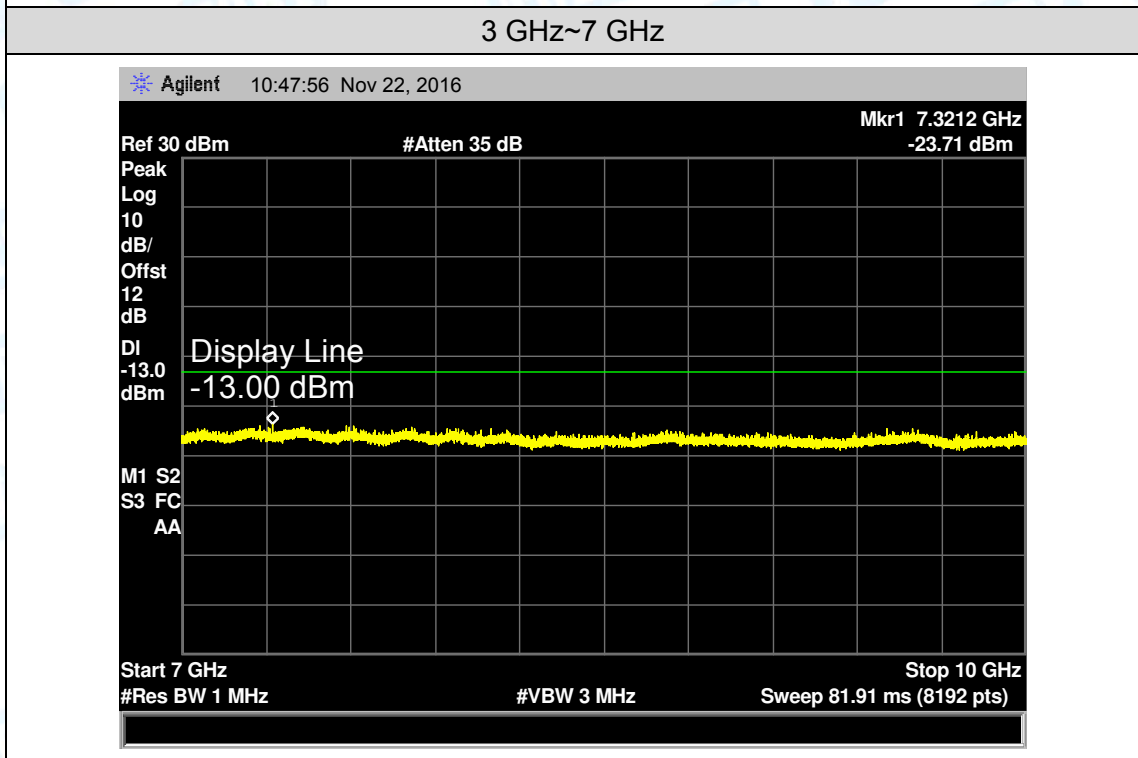
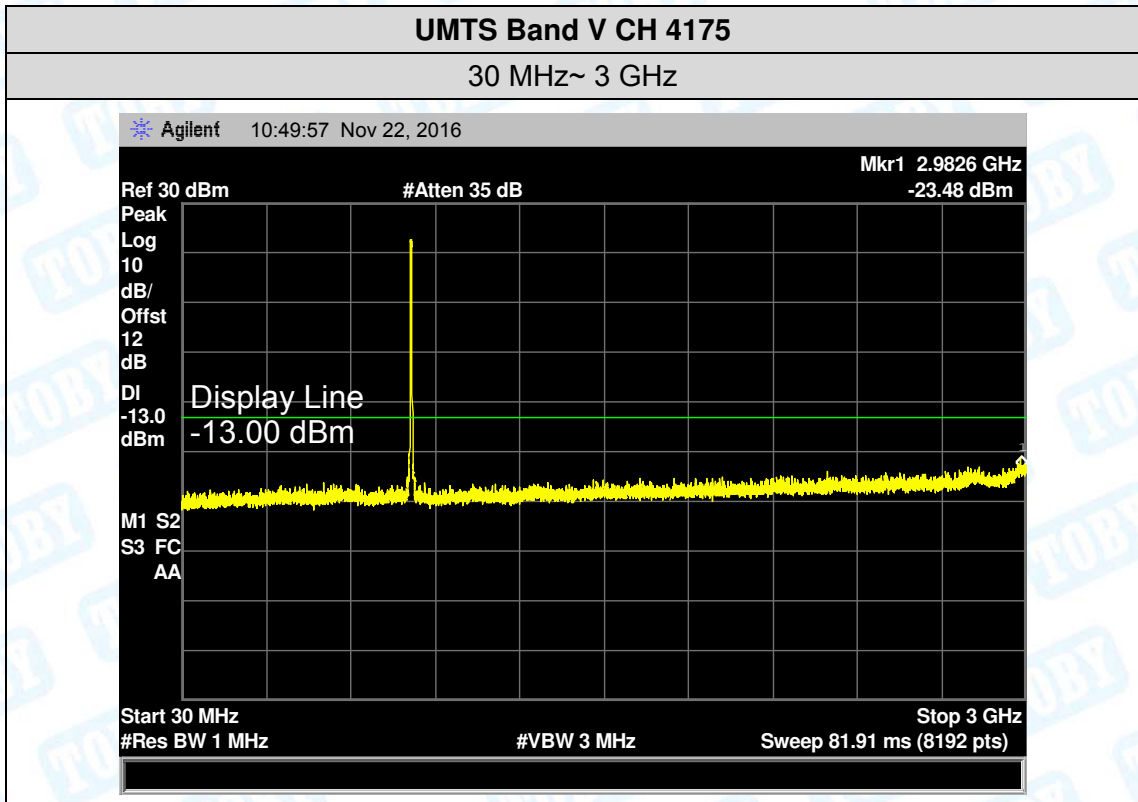

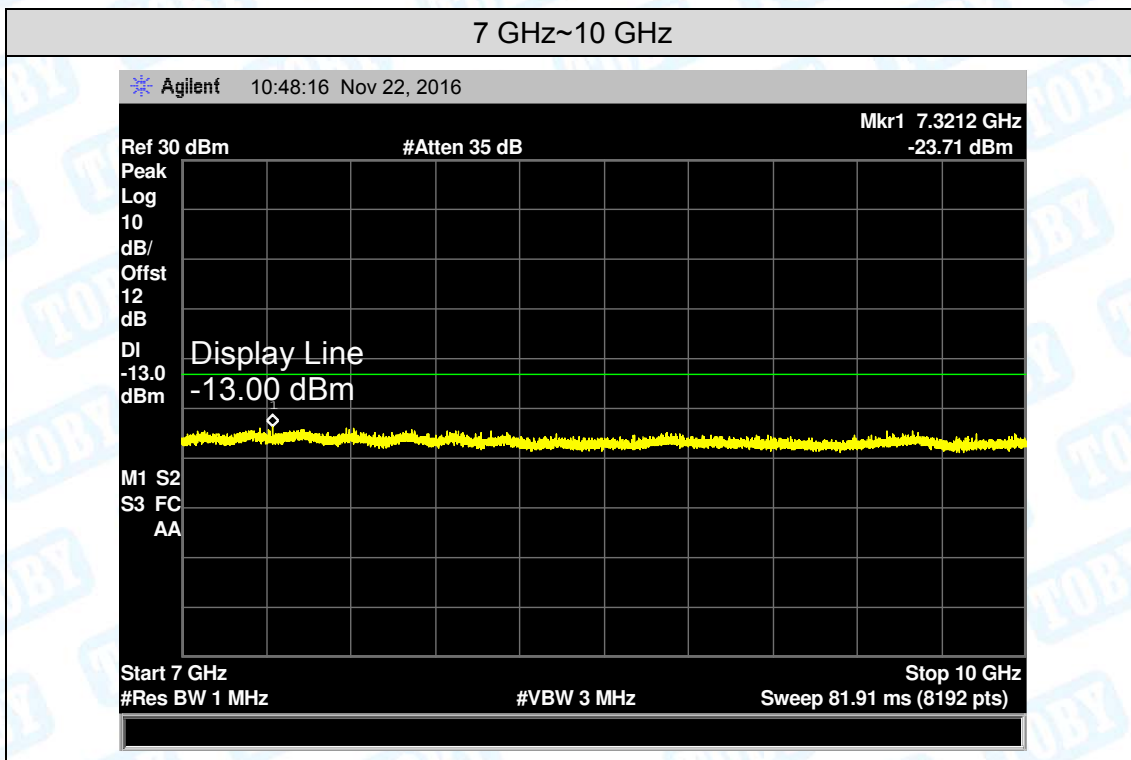

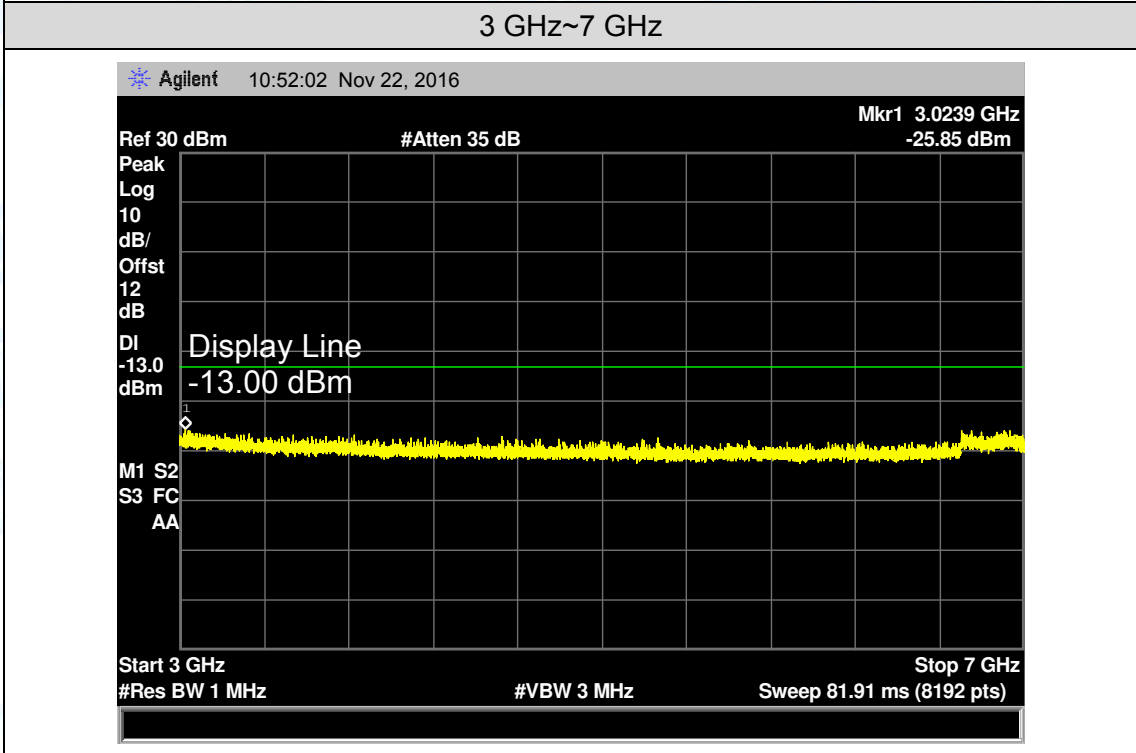
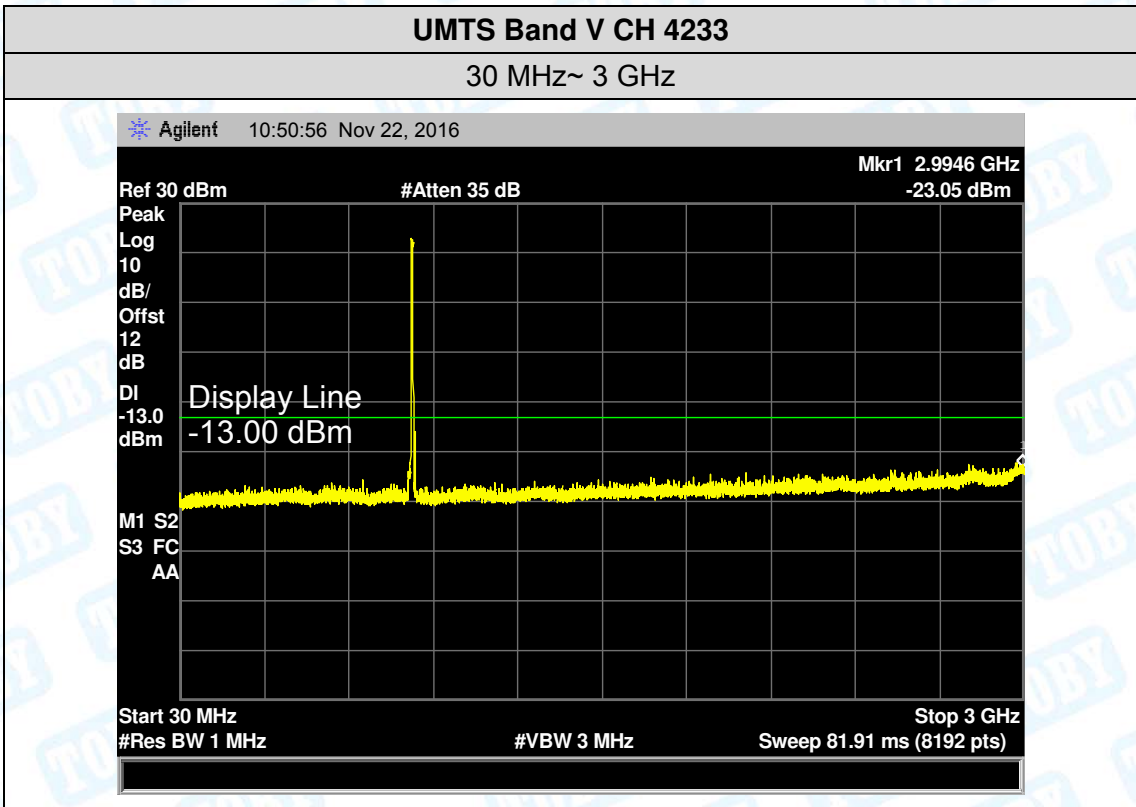

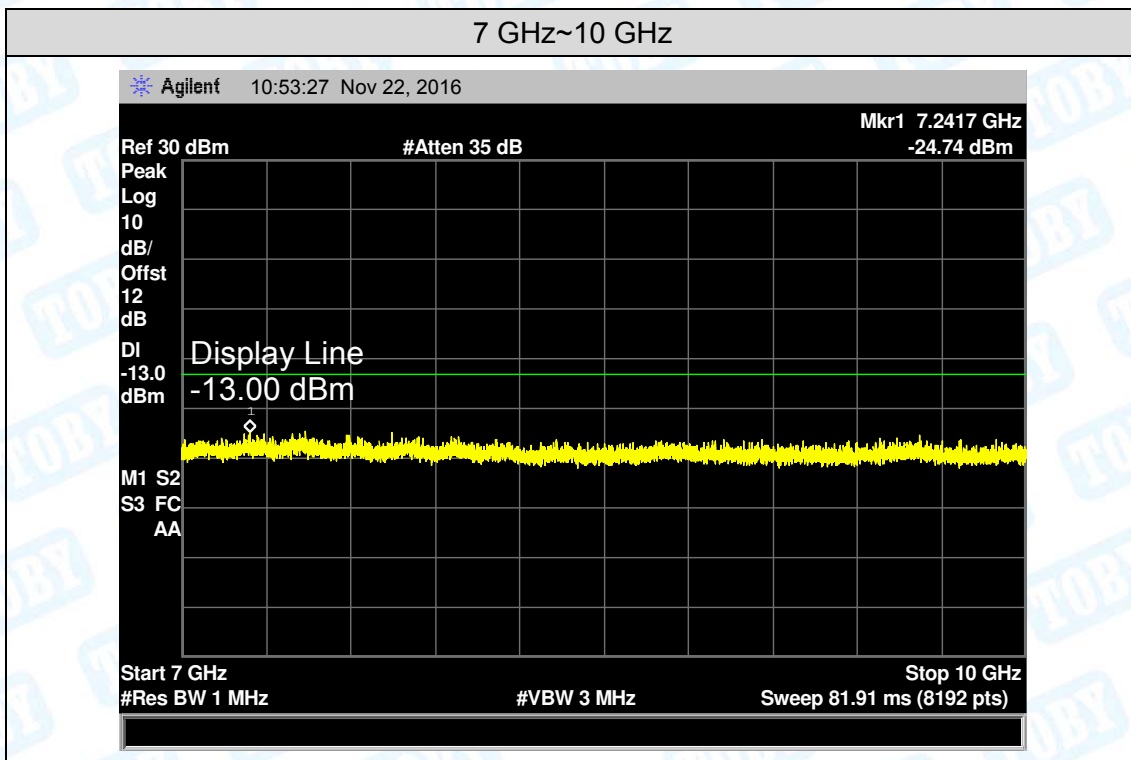

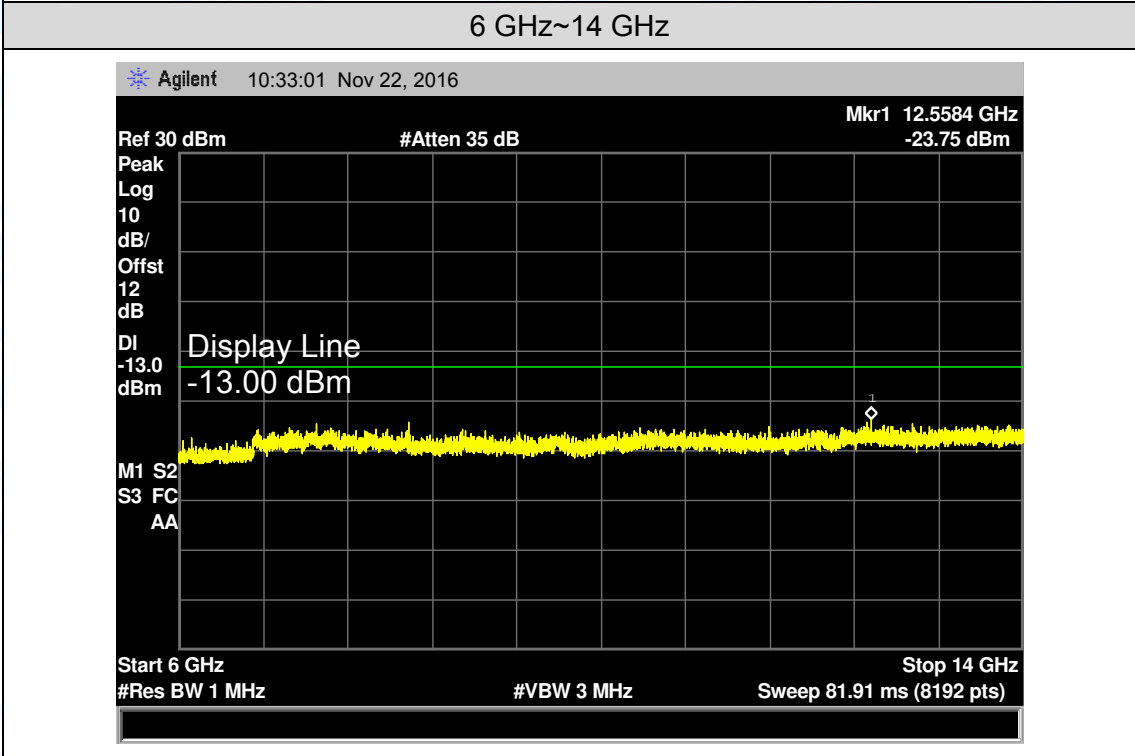
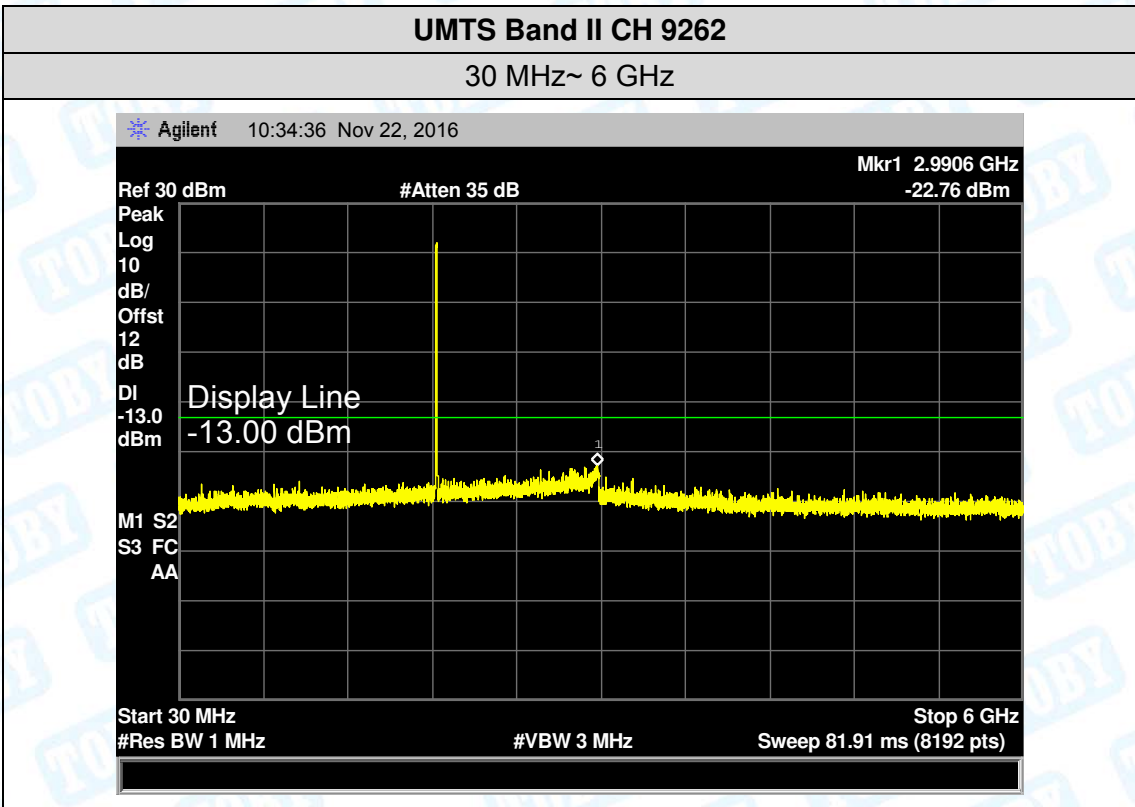

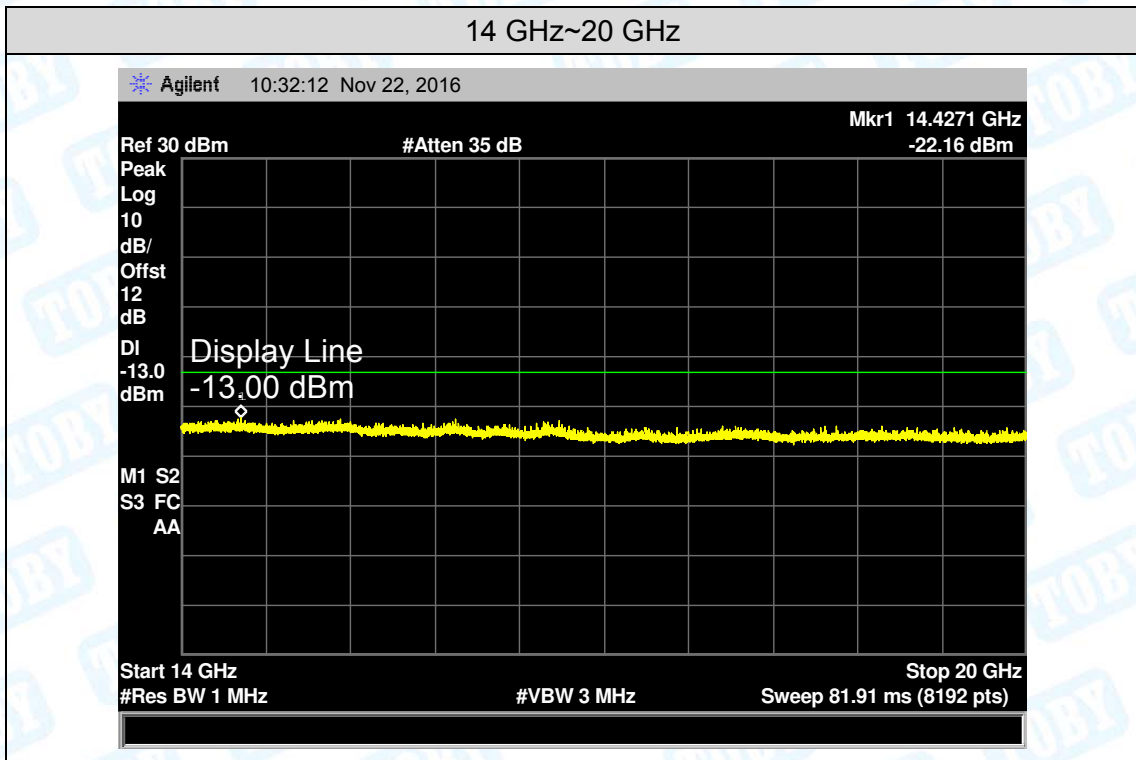

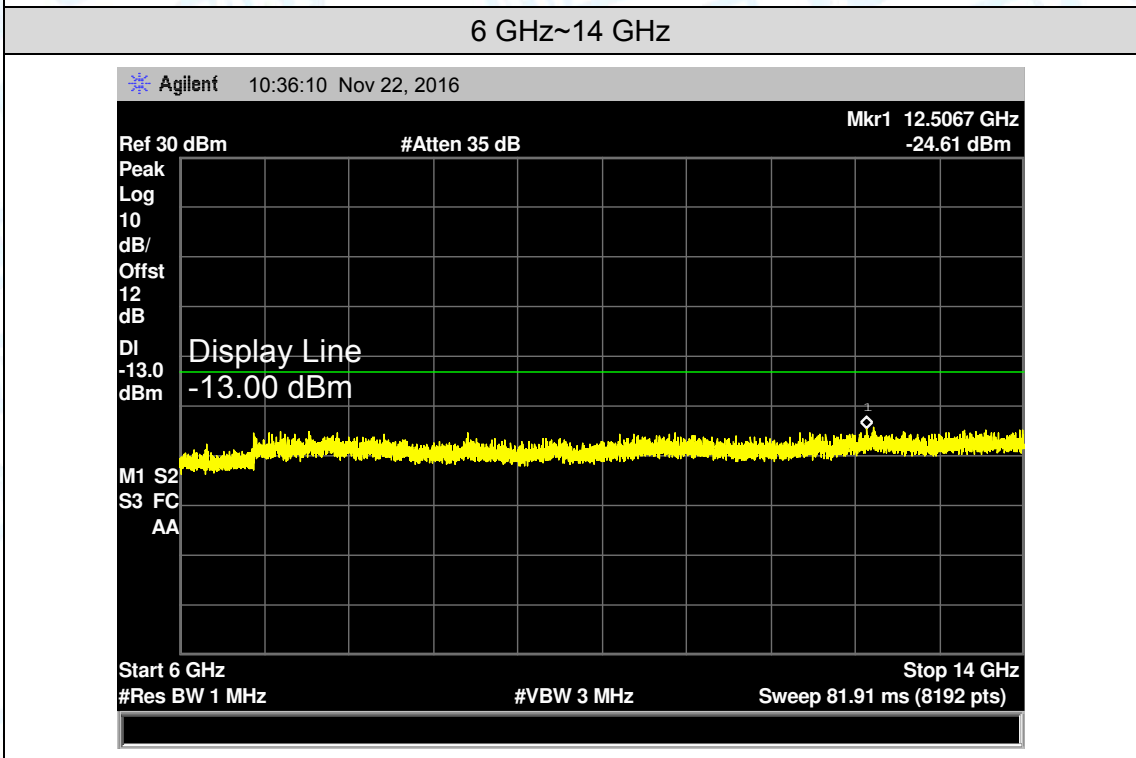
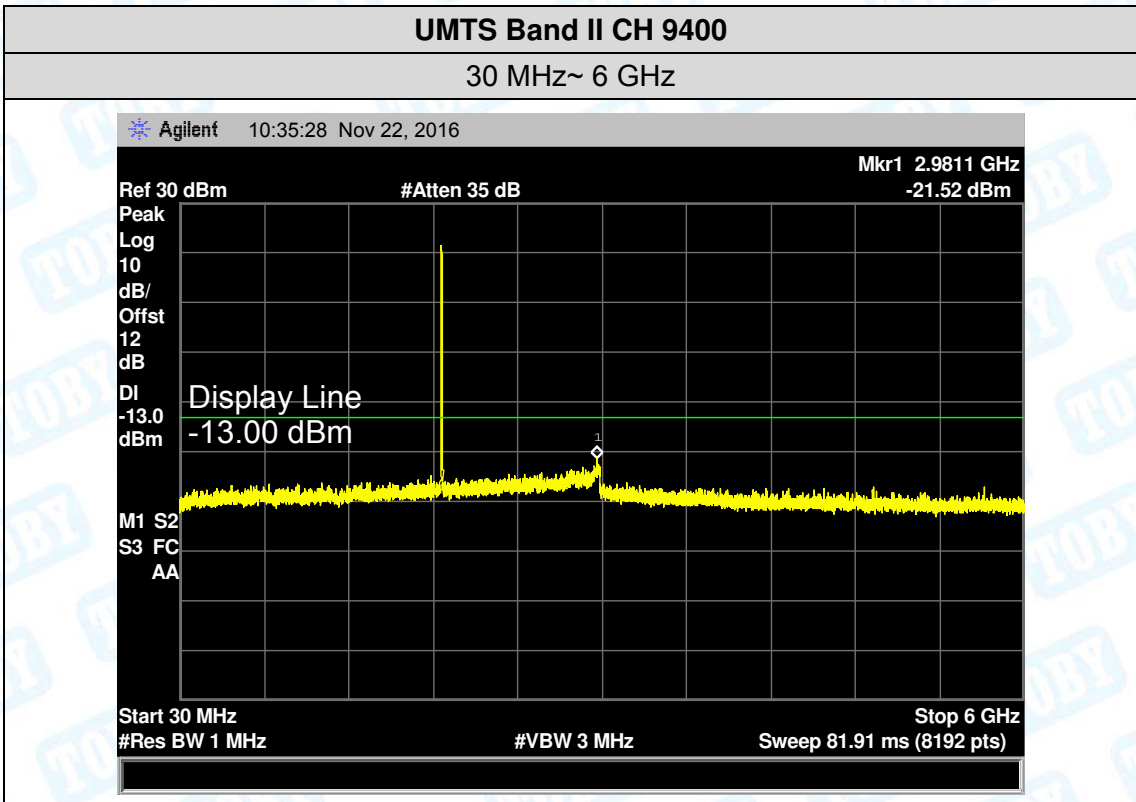

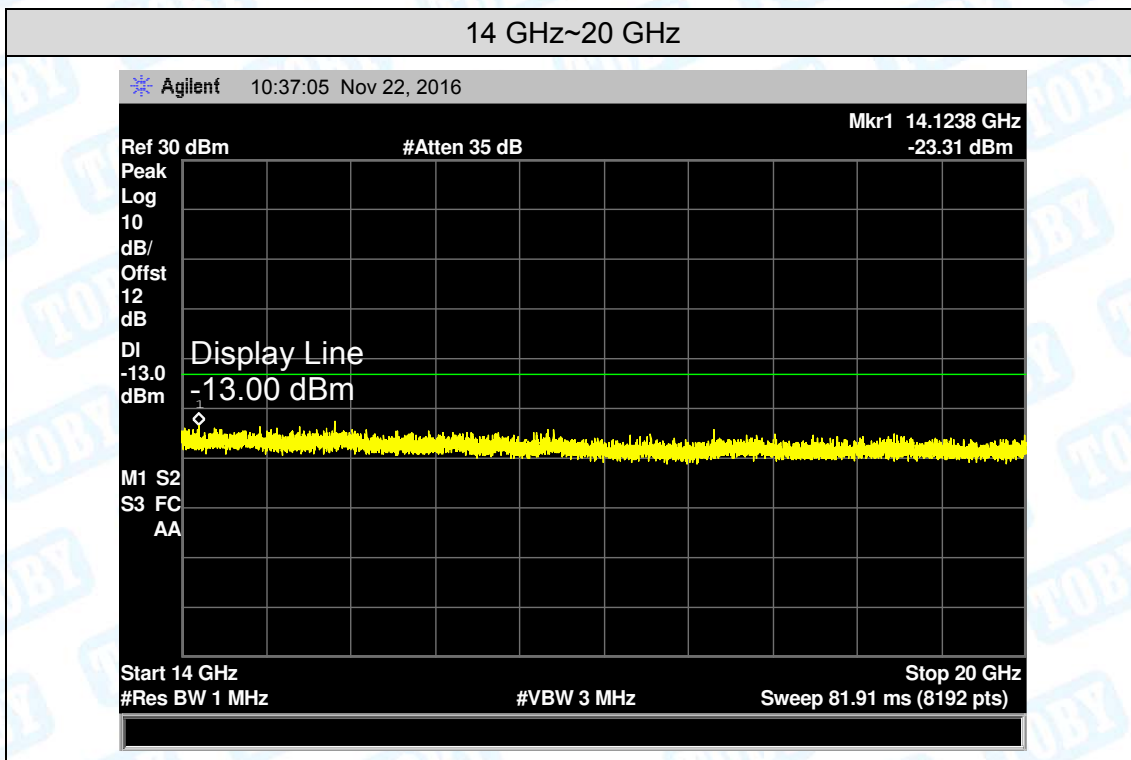



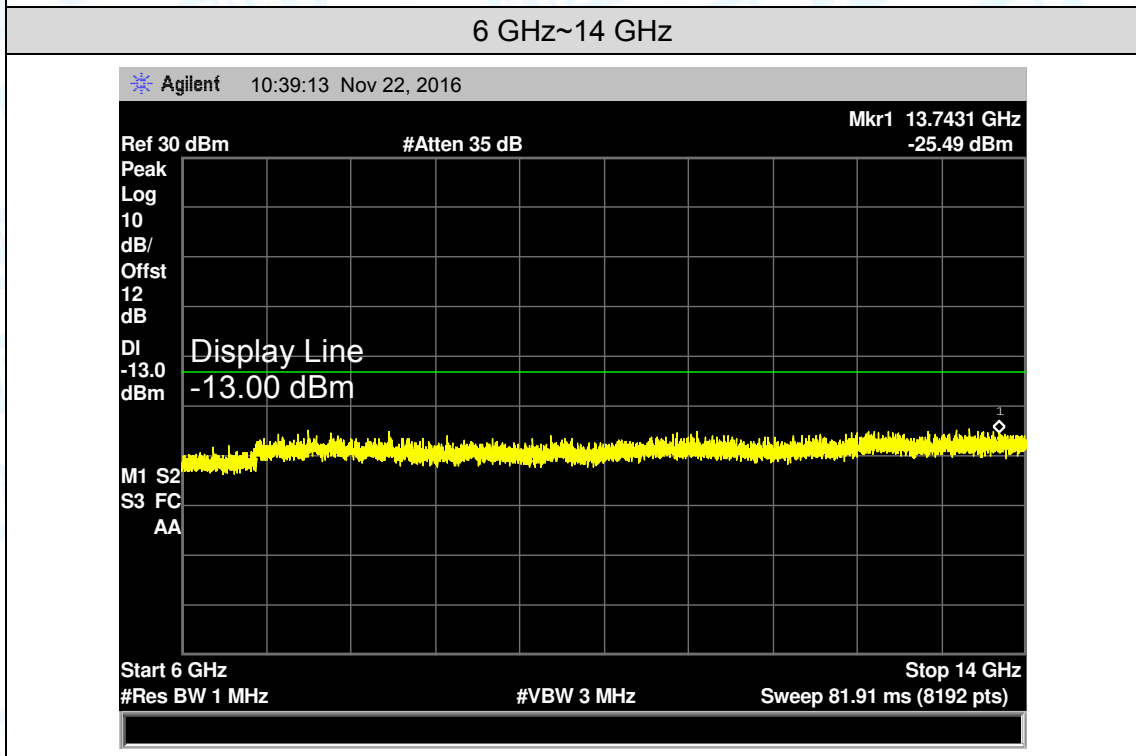
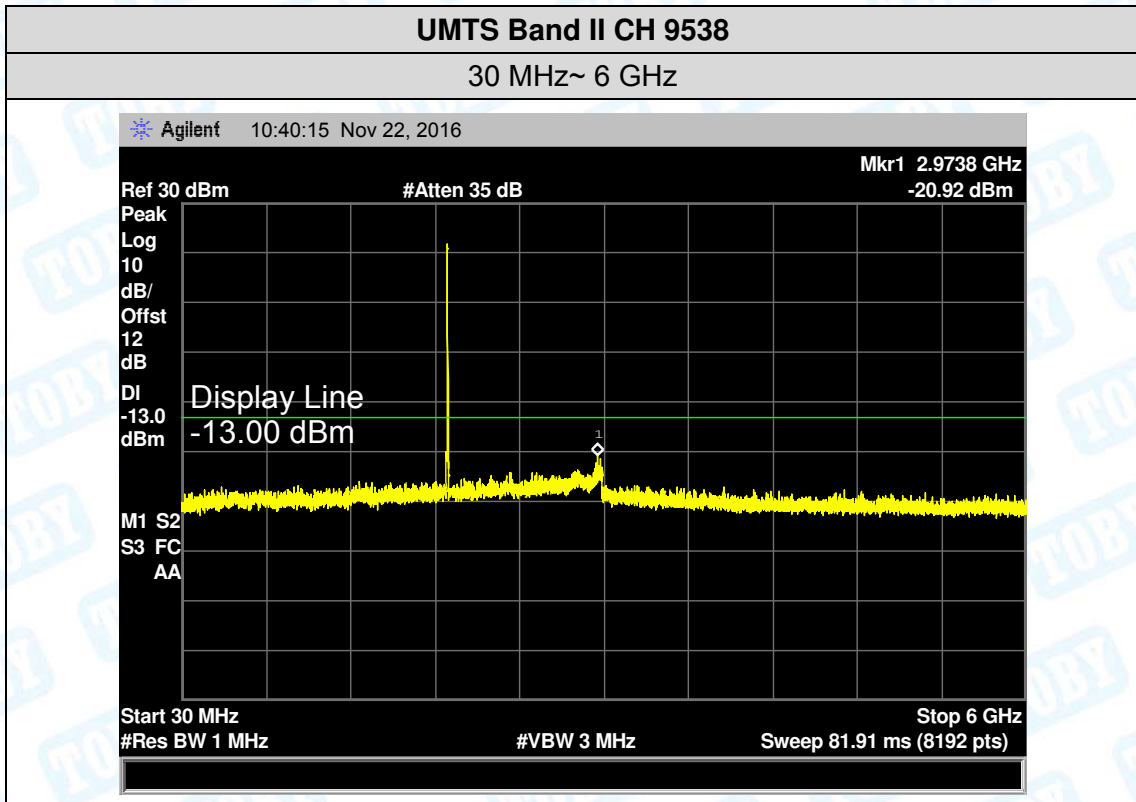

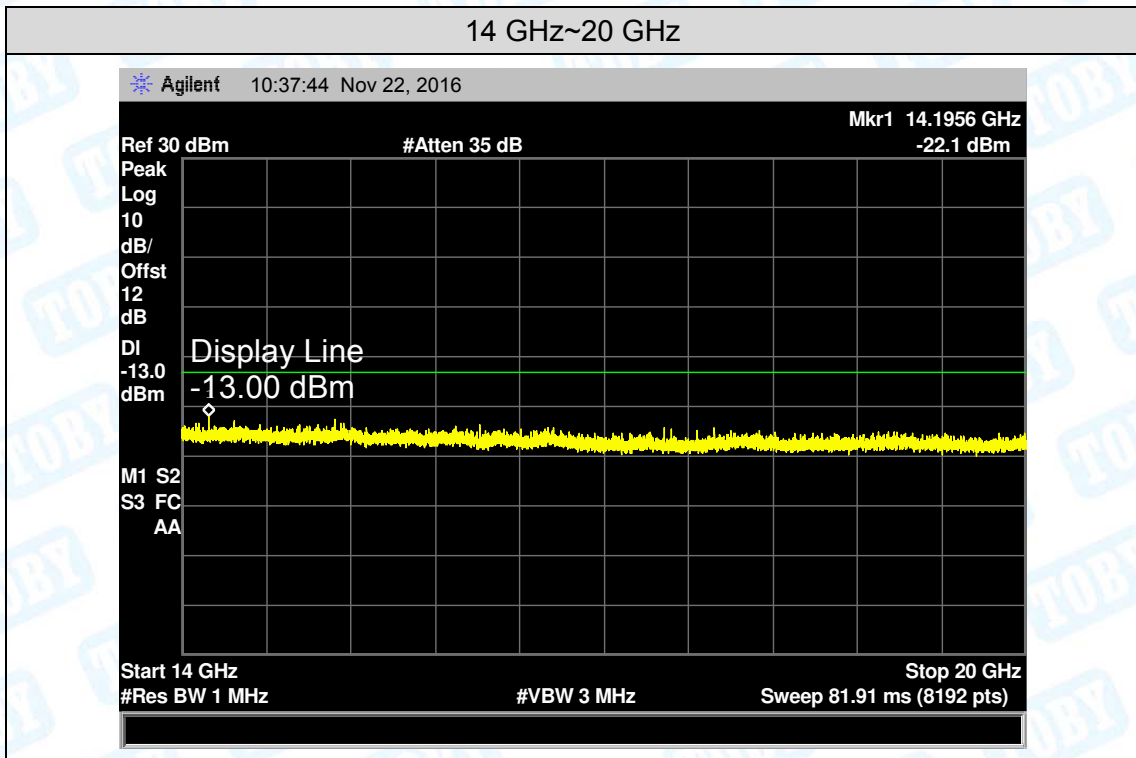

## 10. Band Edge Test

### 10.1 Test Standard and Limit

#### 10.1.1 Test Standard

FCC Part 2: 2.1051, 2.1057

FCC Part 22H: 22.917(a)

FCC Part 24E: 24.238(a)

#### 10.1.2 Test Limit

The power of any emission outside of the authorized operating frequency ranges must be attenuated below the transmitting power(P) by a factor of at least  $43+10\log(P)$  dB. For all power levels +30 dBm to 0 dBm, this becomes a constant specification limit of -13 dBm.

### 10.2 Test Setup

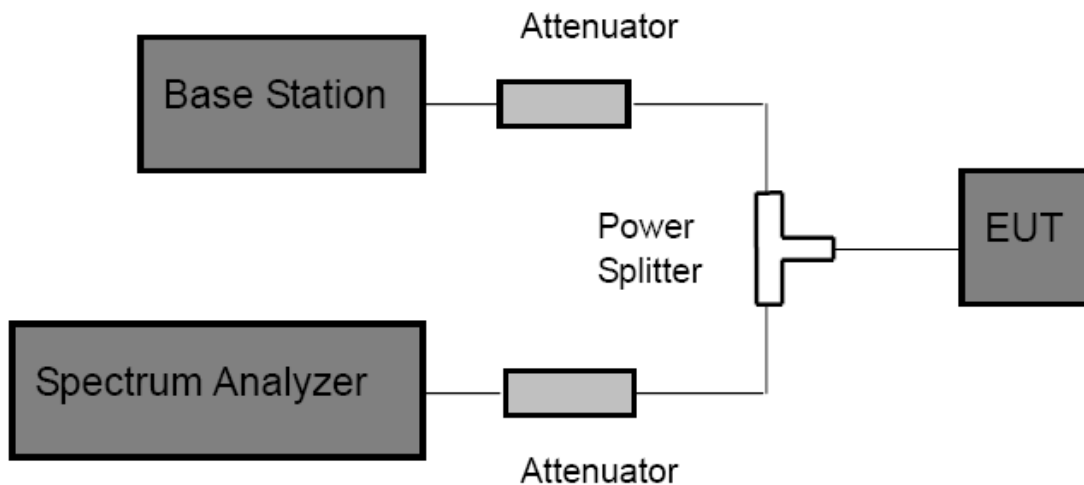

### 10.3 Test Procedure

- (1) The EUT was directly connected to the spectrum analyzer and Base station via power splitter as show in the block diagram above.
- (2) Spectrum Setting:  
 GSM and PCS:  $RBW \geq 1\%$  26db bandwidth,  $VBW=3$  RBW, Span 1 MHz, Detector: Peak Mode.  
 WCDMA:  $RBW \geq 1\%$  26db bandwidth,  $VBW=3$  RBW, Span 10 MHz, Detector: Peak Mode.
- (3) The band edges of low and high channels for the highest RF powers were measured.

### 10.4 EUT Operating Condition

The EUT was continuously connected with the Base station and transmitting in the max power during the test.

### 10.5 Test Data

Please refer the following plots:

Band edge emission:

Test Mode:	GSM850
------------	--------

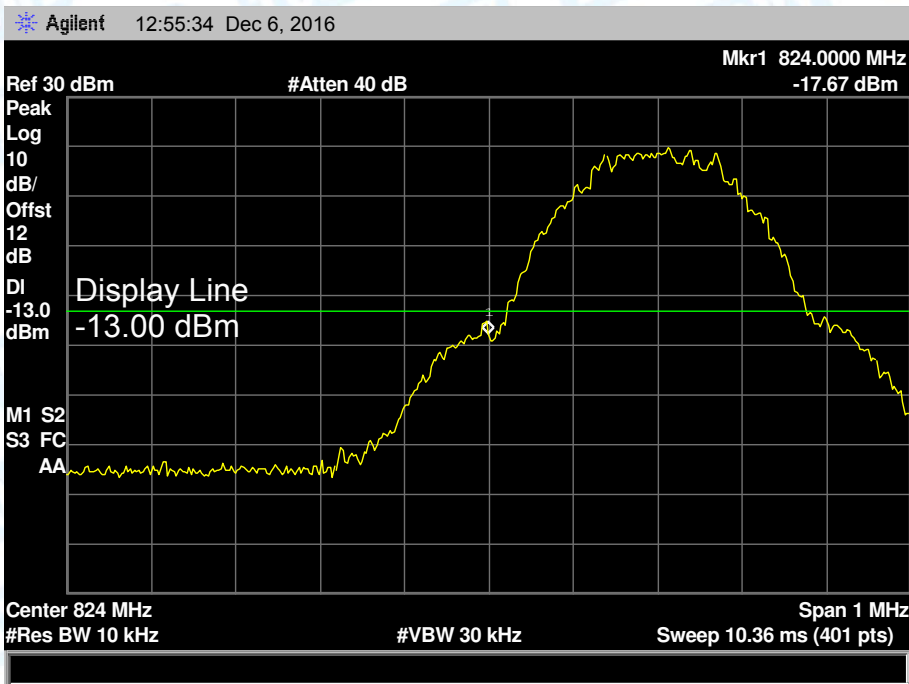

Lowest channel



Highest channel

Test Mode: GPRS850

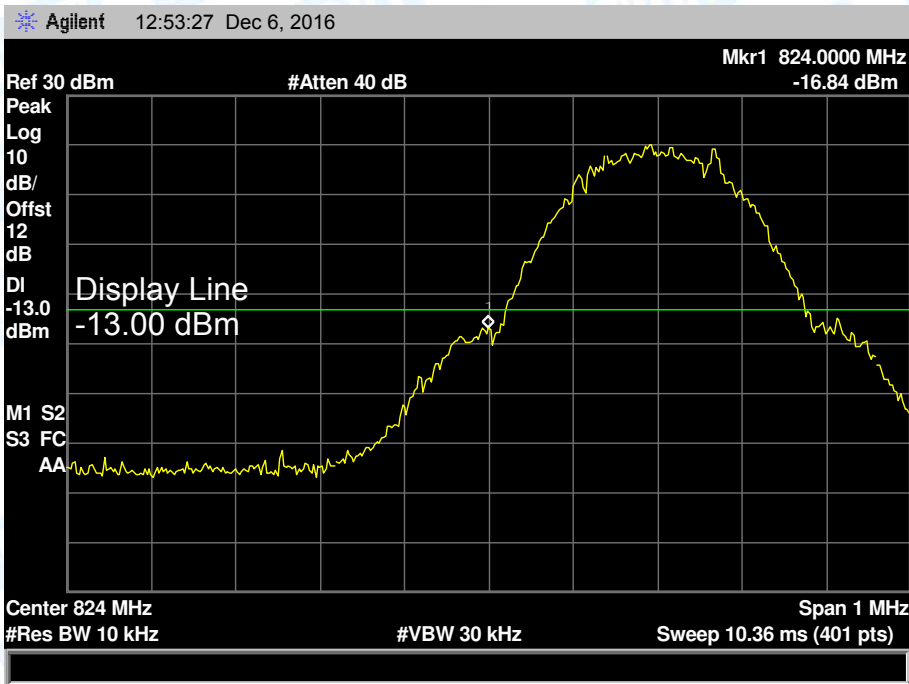

Lowest channel

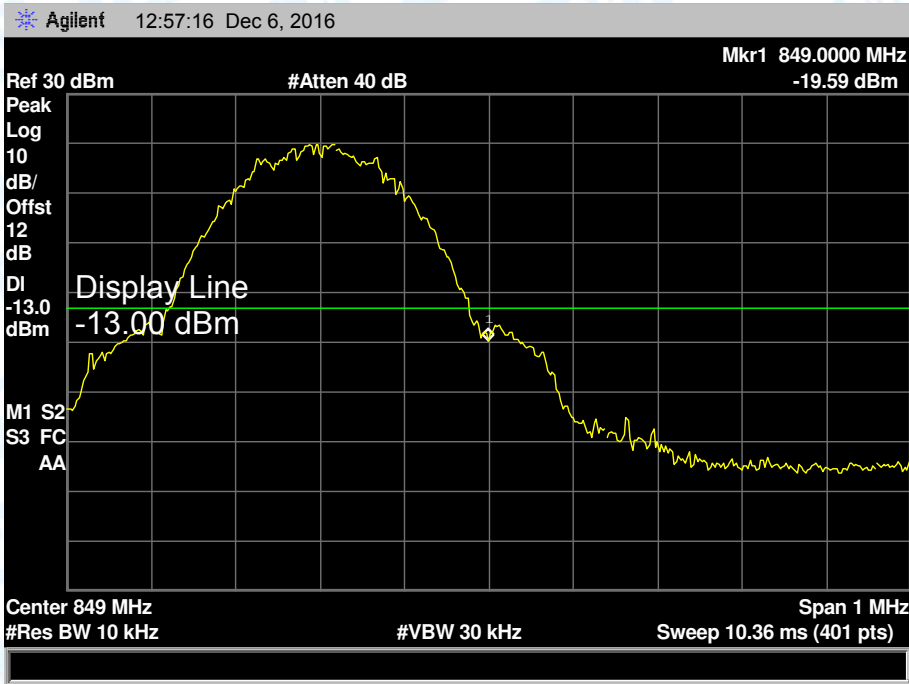

Highest channel

Test Mode:	EDGE850
------------	---------

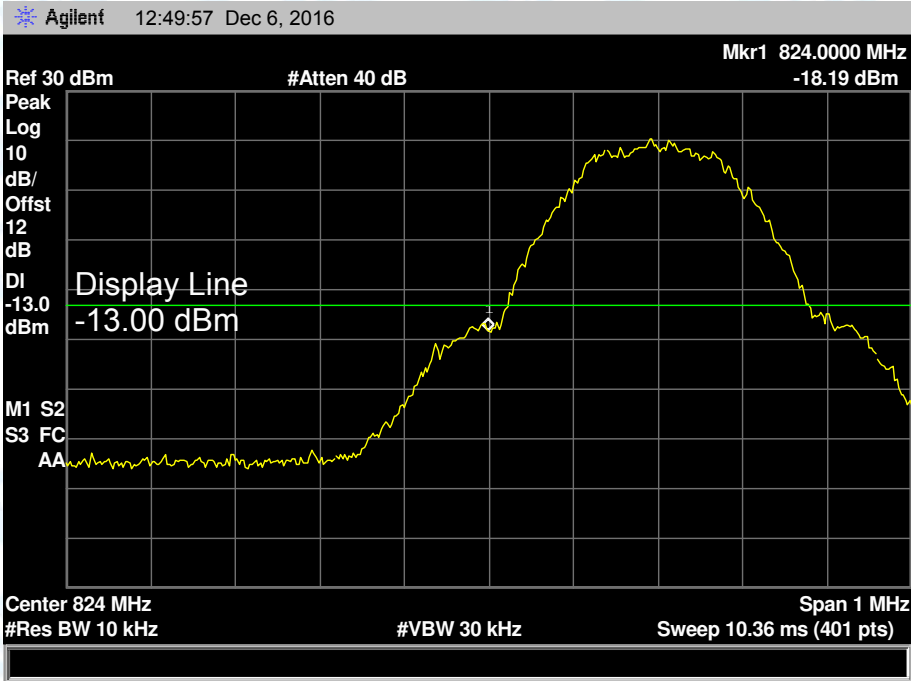

Lowest channel



Highest channel

Test Mode:	PCS1900
------------	---------

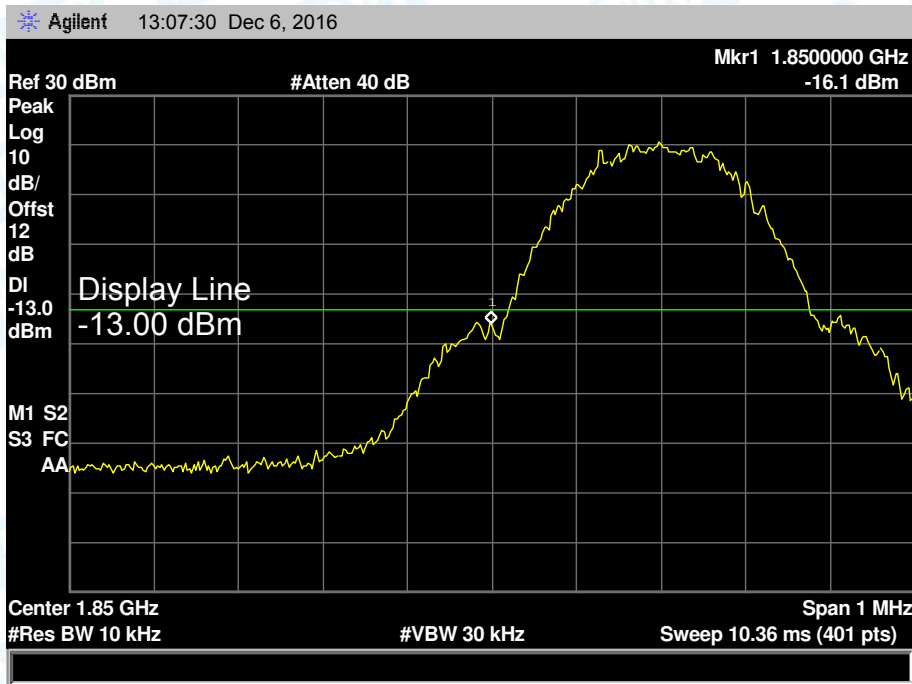

Lowest channel

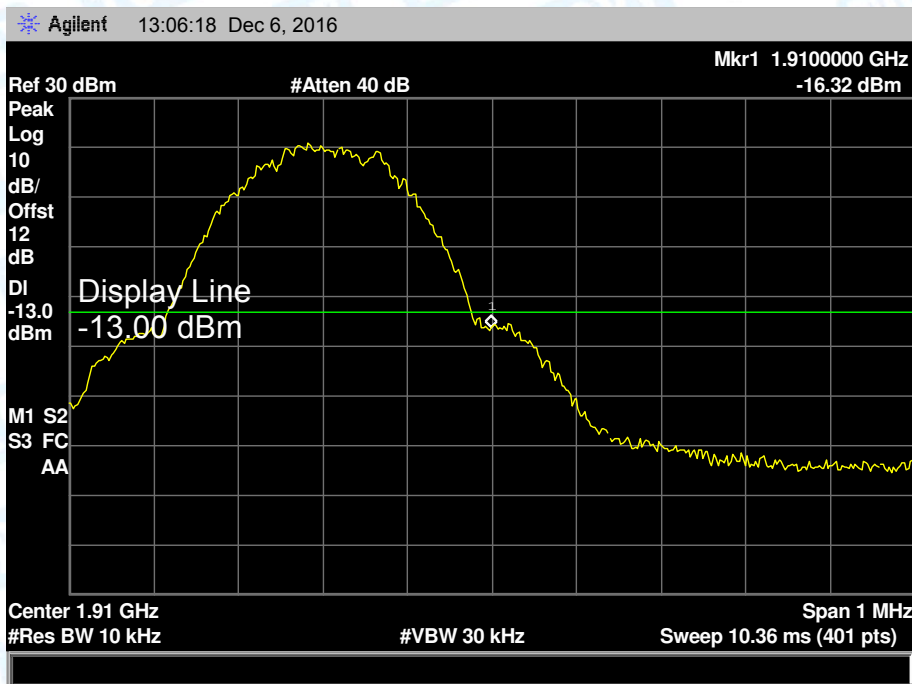

Highest channel

Test Mode: GPRS1900

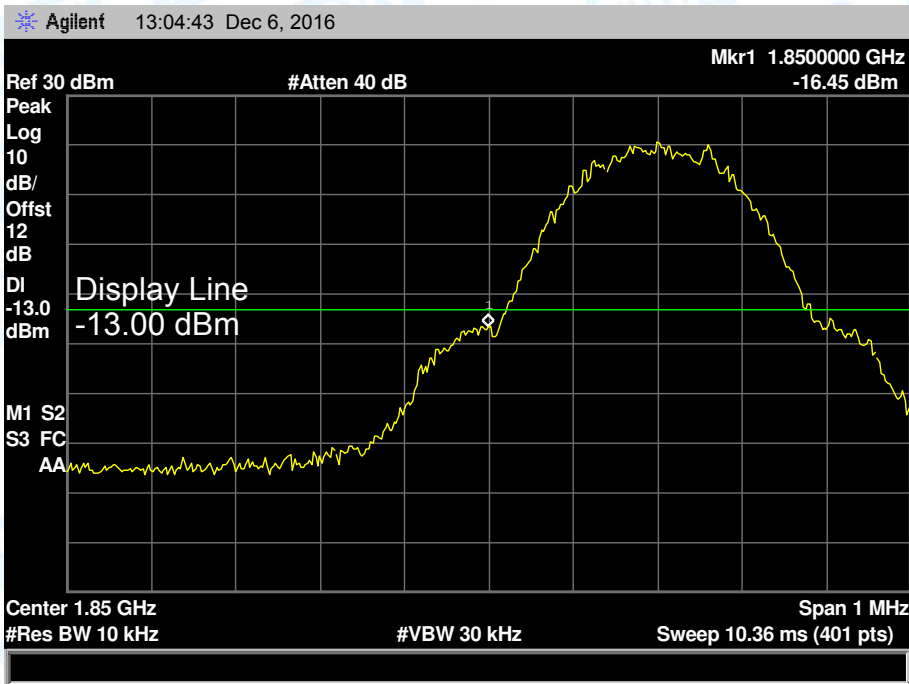

Lowest channel

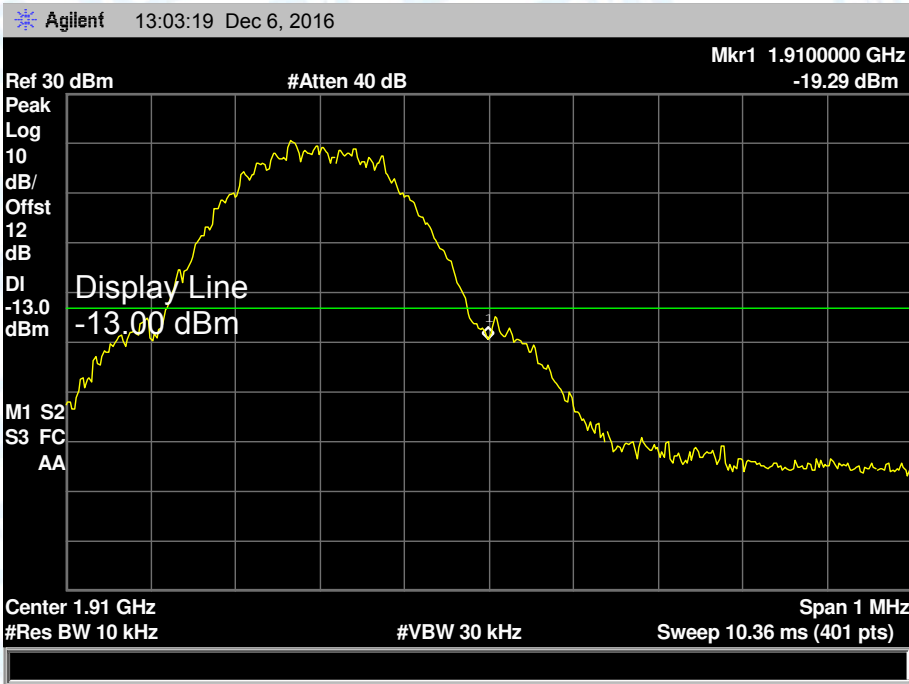

Highest channel



Test Mode: EDGE1900

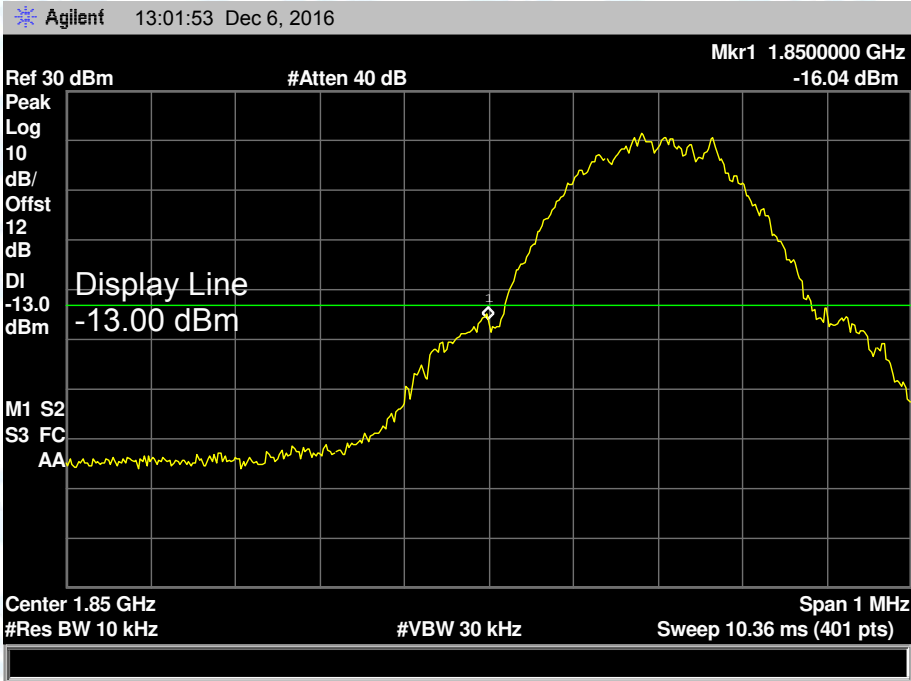

Lowest channel

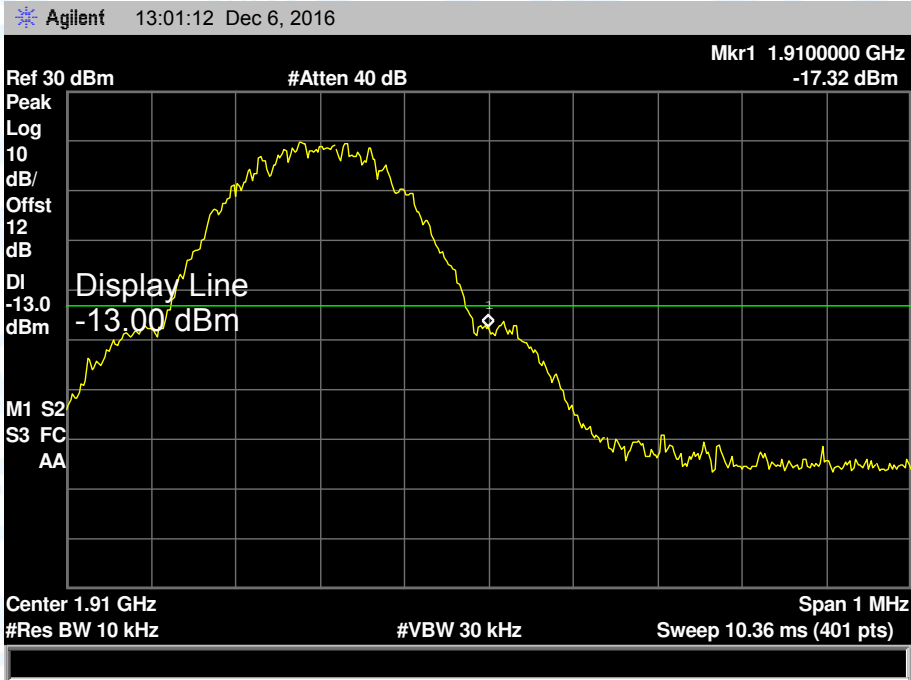

Highest channel

Test Mode: UMTS Band V 12.2k RMC

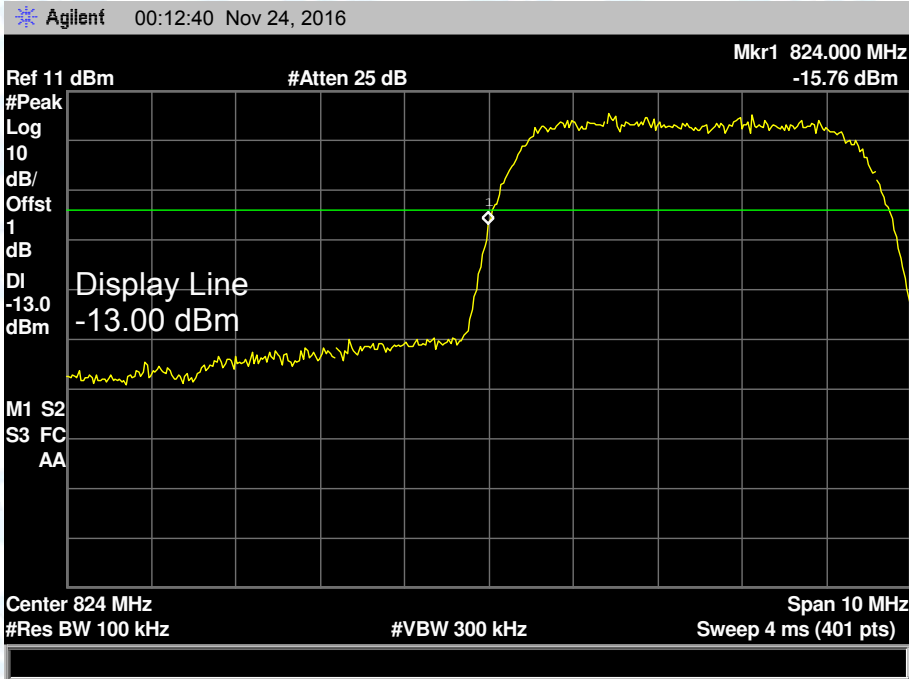

Lowest channel

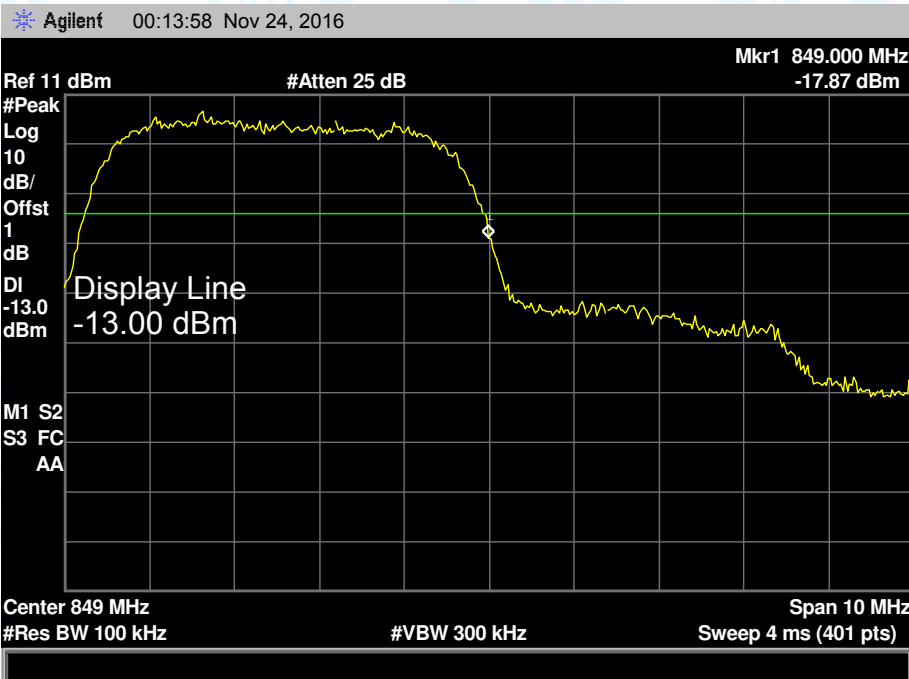

Highest channel

Test Mode: UMTS Band V 12.2k HSDPA

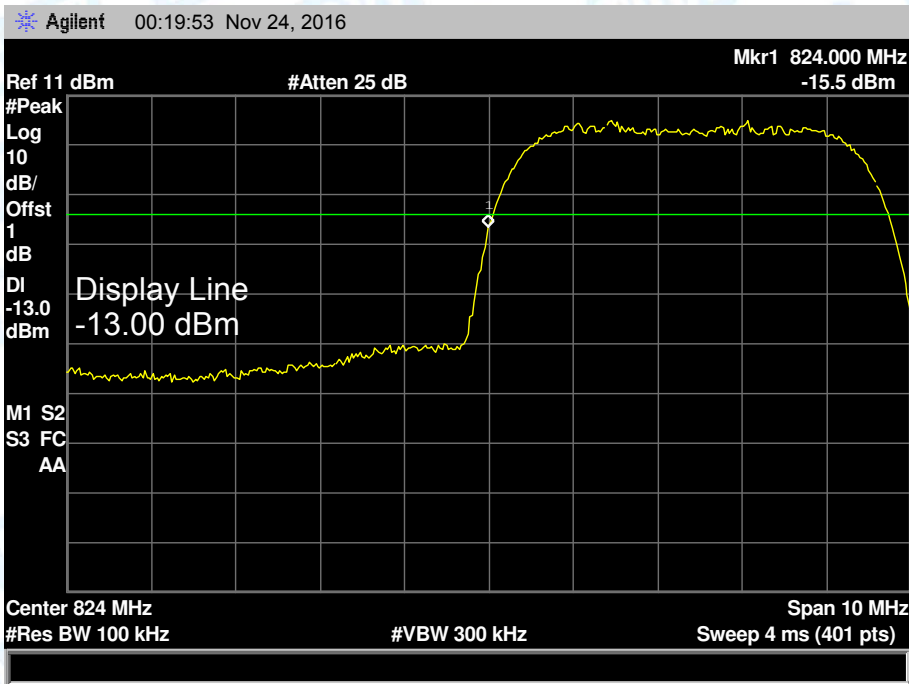

Lowest channel

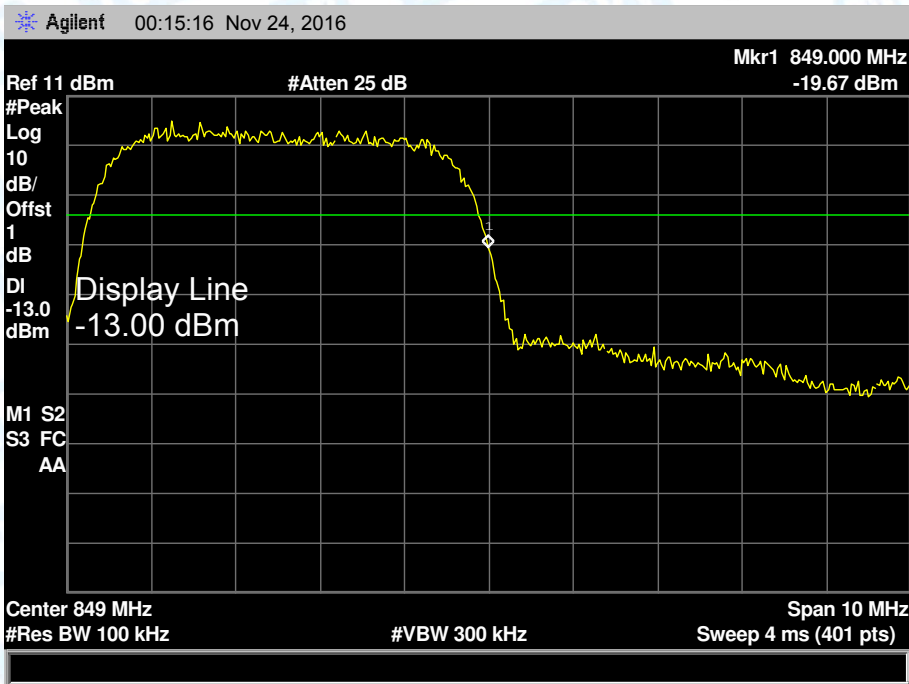

Highest channel

Test Mode: UMTS Band V 12.2k HSUPA

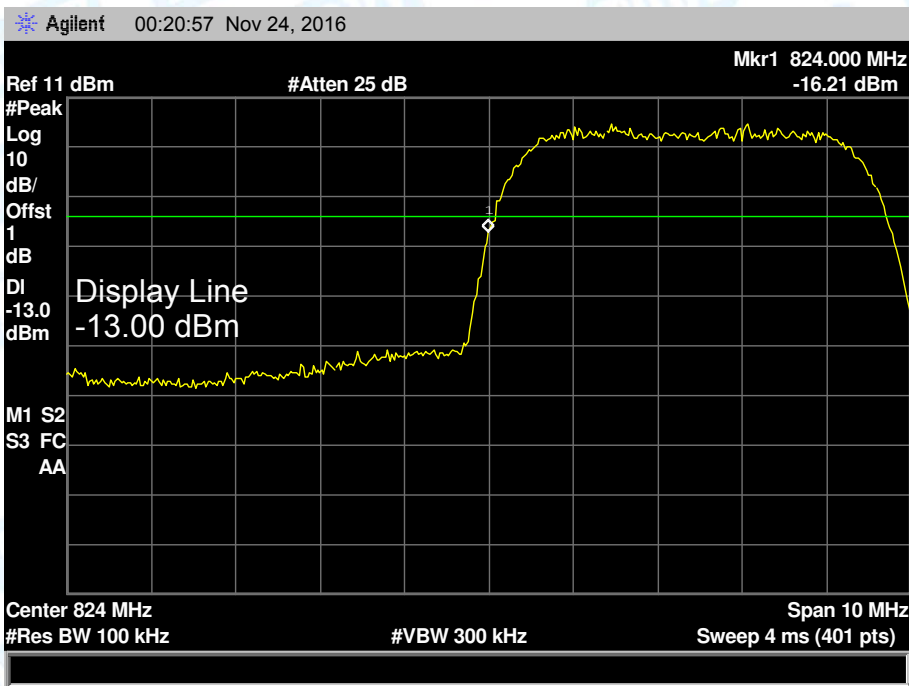

Lowest channel

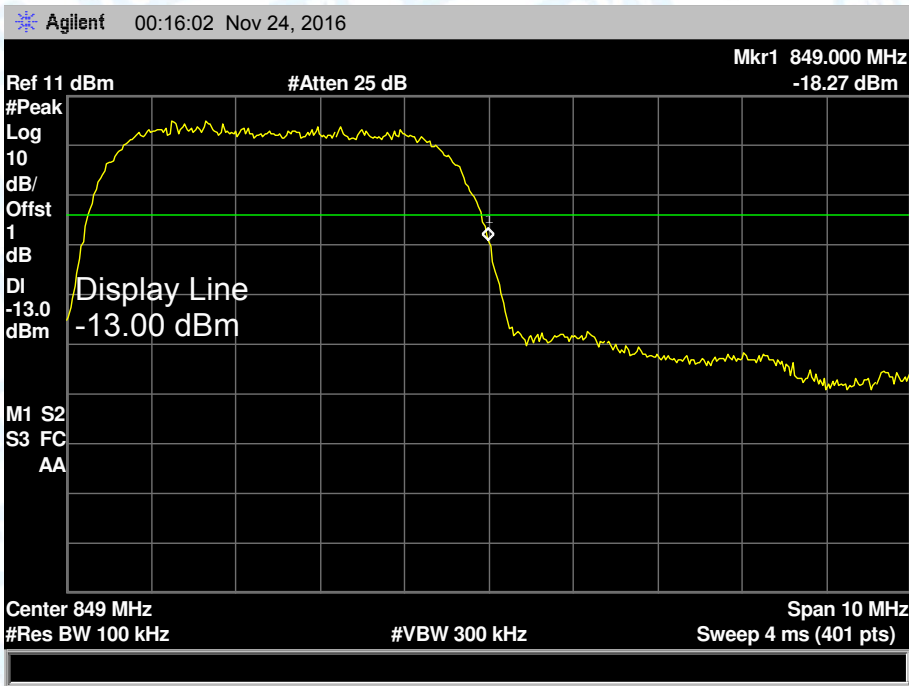

Highest channel

Test Mode: UMTS Band II 12.2k RMC

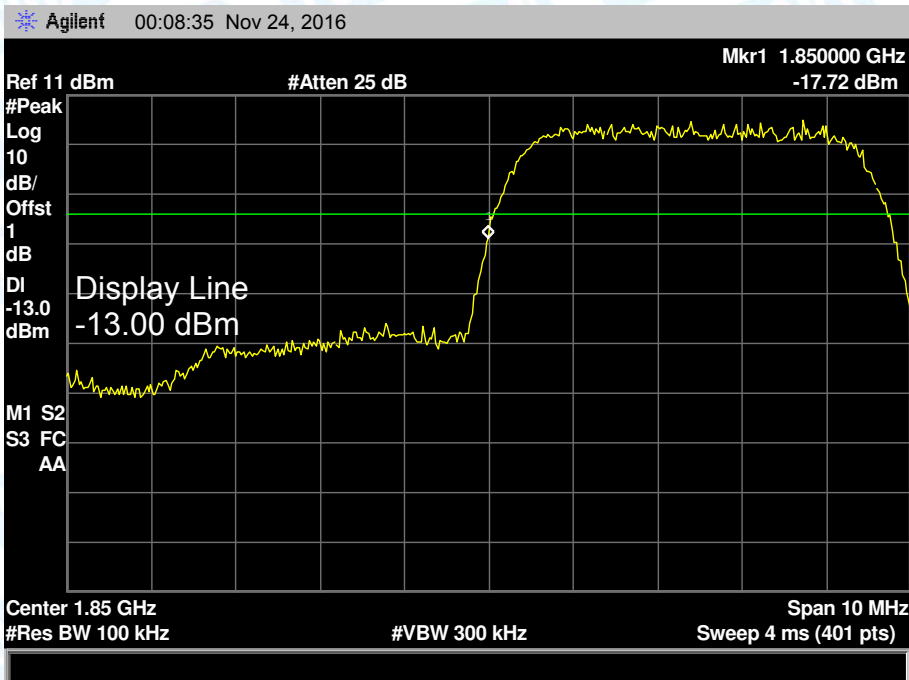

Lowest channel

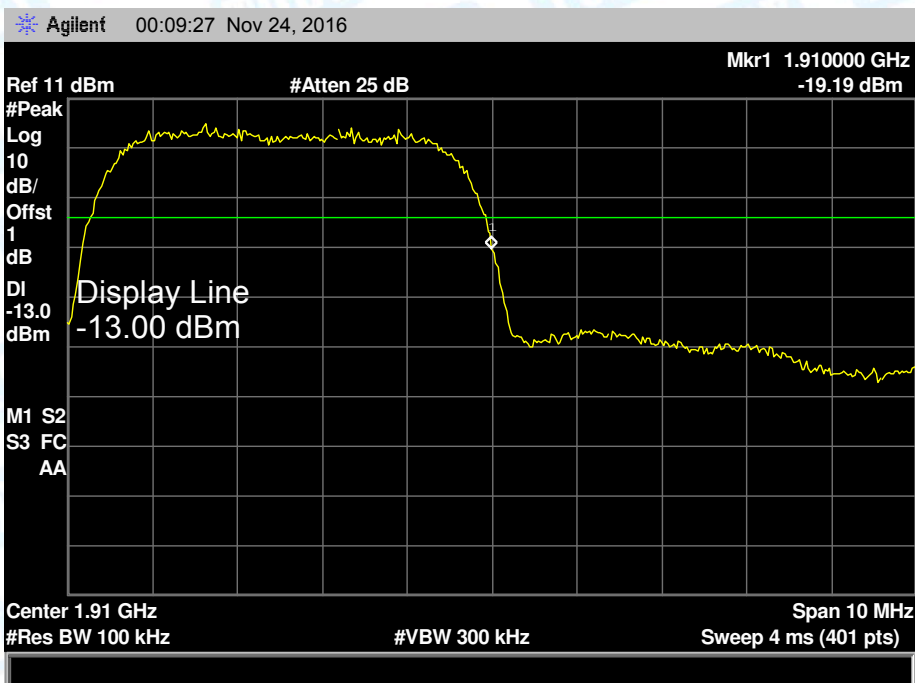

Highest channel

Test Mode: UMTS Band II 12.2k HSDPA

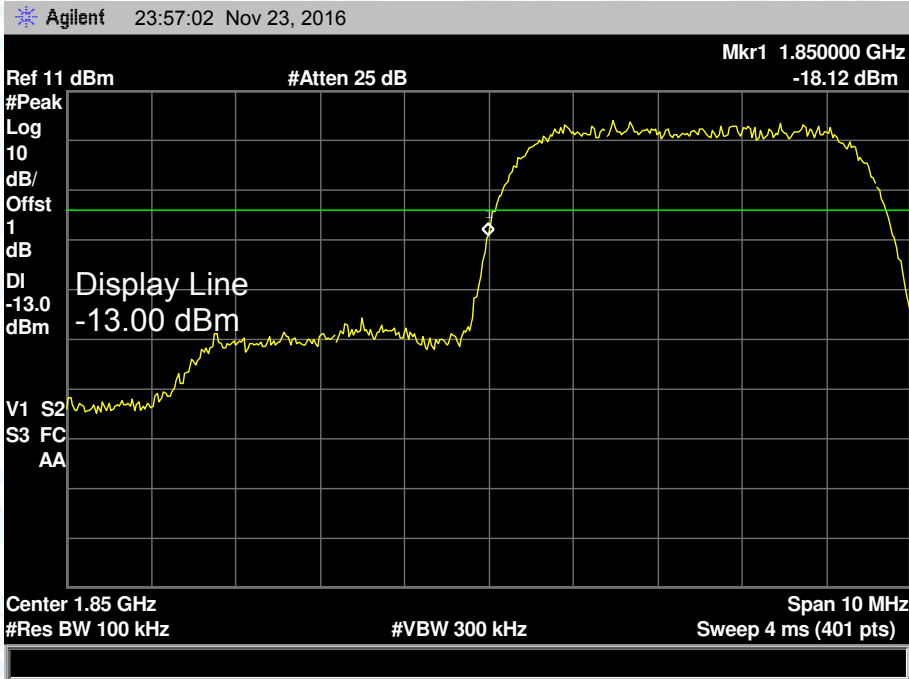

Lowest channel

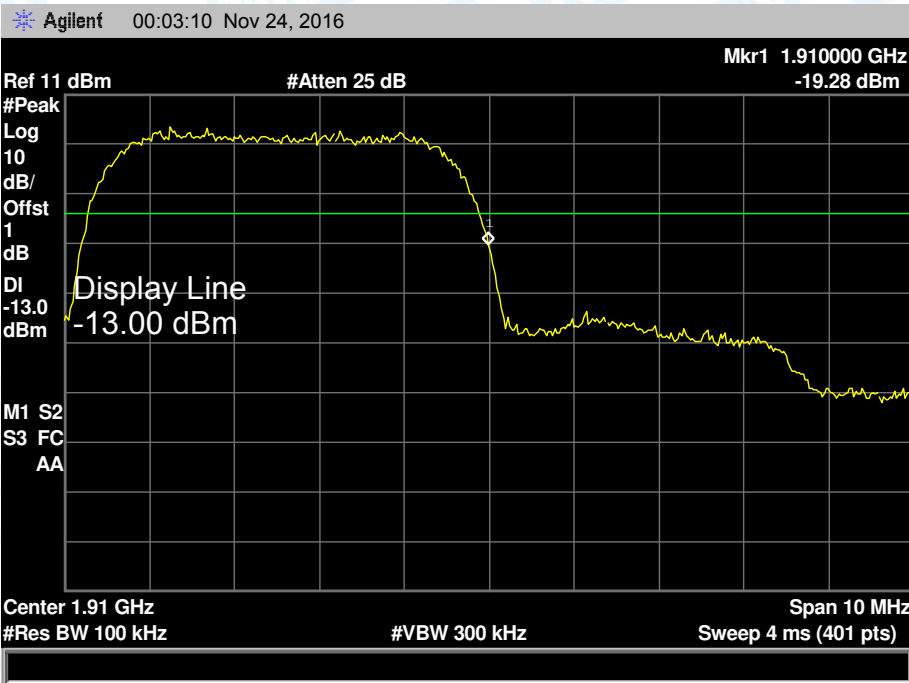

Highest channel

Test Mode: UMTS Band II 12.2k HSUPA

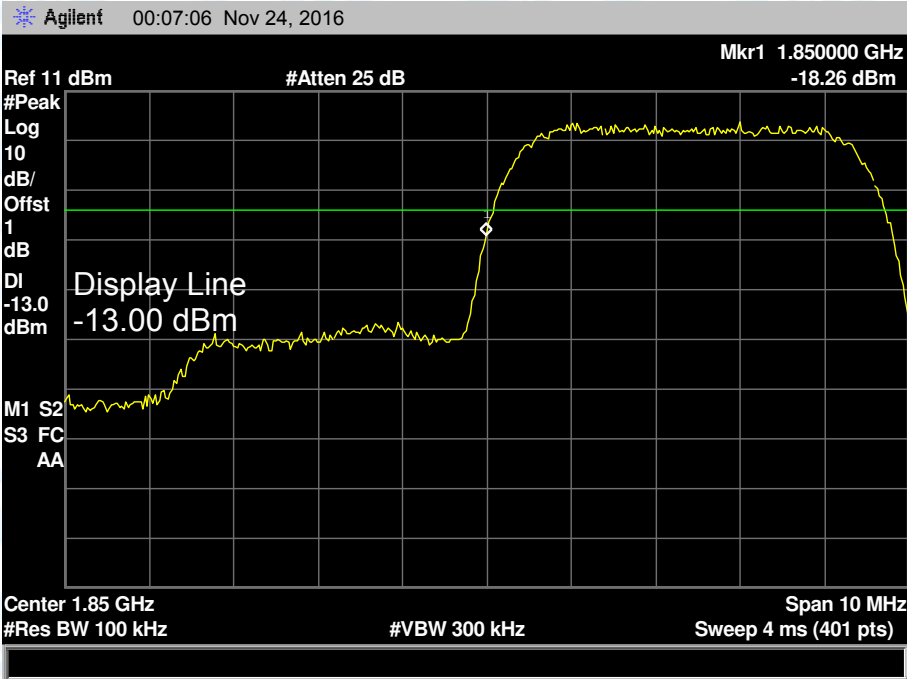

Lowest channel

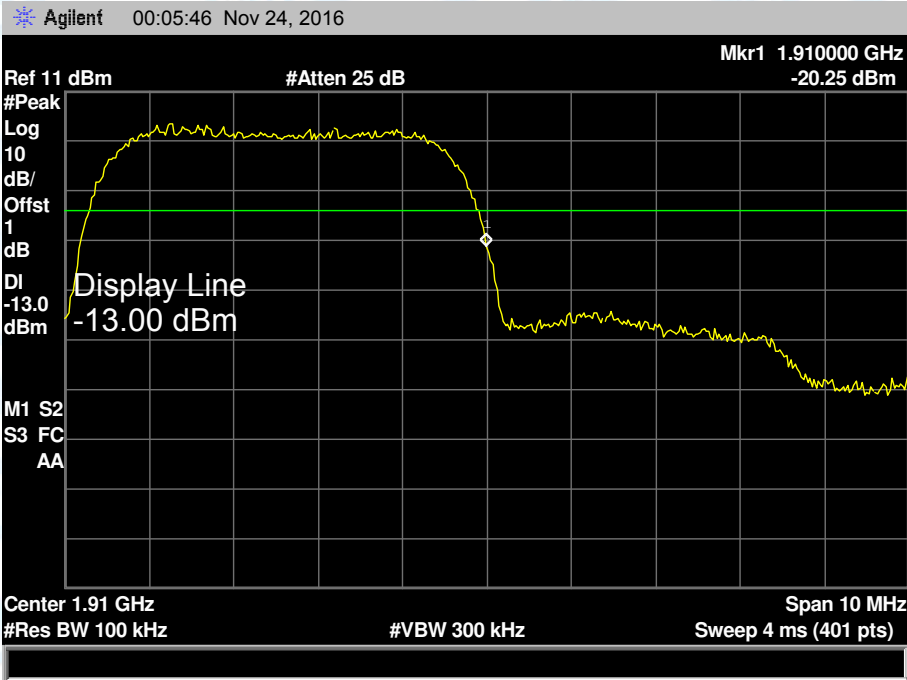

Highest channel

## 11. Radiated Out Band of Emissions

### 11.1 Test Standard and Limit

#### 11.1.1 Test Standard

FCC Part 2: 2.1053, 2.1057

FCC Part 22H: 22.917

FCC Part 24E: 24.238

#### 11.1.2 Test Limit

The power of any emission outside of the authorized operating frequency ranges must be attenuated below the transmitting power(P) by a factor of at least  $43+10\log(P)$  dB. For all power levels +30 dBm to 0 dBm, this becomes a constant specification limit of -13 dBm.

### 11.2 Test Setup

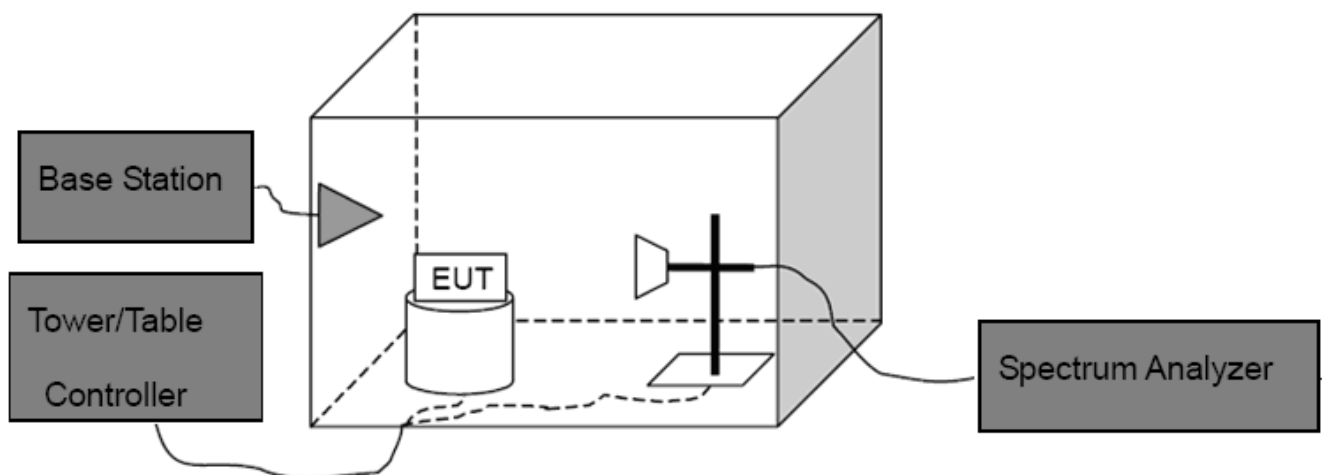

### 11.3 Test Procedure

- (1) The test system setup as show in the block diagram above.
- (2) The EUT was placed on an non-conductive rotating platform in an anechoic chamber. The radiated spurious emissions from 30MHz to 10<sup>th</sup> harmonious of fundamental frequency were measured at 3 m with a test antenna and a spectrum analyzer with RBW=1 MHz, VBW=1 MHz, peak detector settings.
- (3) During the measurement, the EUT was enforced in maximum power and linked with a base station. All the spurious emissions at 3m were measured by rotation of the turntable and the test antenna raised and lowered over a range from 1 to 4 meters in both horizontally and vertically polarized orientations.
- (4) When found the maximum level of emissions from the EUT. Remove the EUT and replace it with substitution antenna. A signal generator was connected to the substitution antenna by a non-radiating cable. The absolute levels of the spurious emissions were measured by the substitution.



Spurious emissions in dB=10 log(TX power in Watts/0.001)-the absolute level  
Spurious attenuation limit in dB=43+10 log(power out in Watts)

#### 11.4 EUT Operating Condition

The EUT was continuously connected with the Base station and transmitting in the max power during the test.

#### 11.5 Test Data

Please refer the following pages.

Measurement Data (worst case)

Test mode: GSM850							
Channel: Middle		Date of Test: 2016-11-22					
Frequency (MHz)	Spurious Emission					Limit (dBm)	Result
	Polarization (H&V)	Read Level (dBm)	Antenna Correct Factor (dBi)	Cable Loss (dB)	Emission Level (dBm)		
1673.20	Horizontal	-29.06	7.49	3.97	-18.06	-13.00	Pass
2509.80	H	-38.21	7.03	5.05	-20.68		
3346.40	H	-44.80	12.48	5.98	-26.34		
4183.00	H	---	---	---	---		
5019.60	H	---	---	---	---		
5856.20	H	---	---	---	---		
1673.20	Vertical	-28.79	8.02	3.97	-14.35	-13.00	Pass
2509.80	V	-41.32	10.47	5.05	-19.35		
3346.40	V	-45.65	16.92	5.98	-24.63		
4183.00	V	---	---	---	---		
5019.60	V	---	---	---	---		
5856.20	V	---	---	---	---		
Test mode: GPRS850							
Channel: Middle		Date of Test: 2016-11-22					
Frequency (MHz)	Spurious Emission					Limit (dBm)	Result
	Polarization (H&V)	Read Level (dBm)	Antenna Correct Factor (dBi)	Cable Loss (dB)	Emission Level (dBm)		
1673.20	Horizontal	-27.34	7.49	3.97	-16.34	-13.00	Pass
2509.80	H	-39.00	7.03	5.05	-21.47		
3346.40	H	-44.87	12.48	5.98	-26.41		
4183.00	H	---	---	---	---		
5019.60	H	---	---	---	---		
5856.20	H	---	---	---	---		
1673.20	Vertical	-28.11	8.02	3.97	-13.67	-13.00	Pass
2509.80	V	-39.39	10.47	5.05	-17.42		
3346.40	V	-45.78	16.92	5.98	-24.76		
4183.00	V	---	---	---	---		
5019.60	V	---	---	---	---		
5856.20	V	---	---	---	---		
Remark: 1, The testing has been conformed to 10*836.6MHz=8,366MHz. 2, All other emissions more than 30 dB below the limit. 3, Emission Level= Read Level+ Antenna Correct Factor +Cable Loss							

Test mode: EDGE850							
Channel: Middle			Date of Test: 2016-11-22				
Frequency (MHz)	Spurious Emission					Limit (dBm)	Result
	Polarization (H&V)	Read Level (dBm)	Antenna Correct Factor (dBi)	Cable Loss (dB)	Emission Level (dBm)		
1673.20	Horizontal	-27.74	7.49	3.97	-16.74	-13.00	Pass
2509.80	H	-40.20	7.03	5.05	-22.67		
3346.40	H	-47.28	12.48	5.98	-28.82		
4183.00	H	---	---	---	---		
5019.60	H	---	---	---	---		
5856.20	H	---	---	---	---		
1673.20	Vertical	-28.11	8.02	3.97	-13.67	-13.00	Pass
2509.80	V	-40.42	10.47	5.05	-18.45		
3346.40	V	-45.67	16.92	5.98	-24.65		
4183.00	V	---	---	---	---		
5019.60	V	---	---	---	---		
5856.20	V	---	---	---	---		

Remark: 1, The testing has been conformed to  $10 \times 836.6\text{MHz} = 8,366\text{MHz}$ .  
 2, All other emissions more than 30 dB below the limit.  
 3, Emission Level= Read Level+ Antenna Correct Factor +Cable Loss

Test mode: PCS1900							
Channel: Middle		Date of Test: 2016-11-22					
Frequency (MHz)	Spurious Emission					Limit (dBm)	Result
	Polarization (H&V)	Read Level (dBm)	Antenna Correct Factor (dBi)	Cable Loss (dB)	Emission Level (dBm)		
3760.00	Horizontal	-37.56	14.70	6.12	-16.74	-13.00	Pass
5640.00	H	-41.77	13.67	7.86	-20.24		
7520.00	H	-49.46	14.27	9.54	-25.65		
9400.00	H	---	---	---	---		
11280.00	H	---	---	---	---		
13160.00	H	---	---	---	---		
3760.00	Vertical	-35.60	15.81	6.12	-13.67	-13.00	Pass
5640.00	V	-40.01	13.80	7.86	-18.35		
7520.00	V	-45.38	13.40	9.54	-22.44		
9400.00	V	---	---	---	---		
11280.00	V	---	---	---	---		
13160.00	V	---	---	---	---		

Test mode: GPRS1900							
Channel: Middle		Date of Test: 2016-11-22					
Frequency (MHz)	Spurious Emission					Limit (dBm)	Result
	Polarization (H&V)	Read Level (dBm)	Antenna Correct Factor (dBi)	Cable Loss (dB)	Emission Level (dBm)		
3760.00	Horizontal	-36.44	14.70	6.12	-15.62	-13.00	Pass
5640.00	H	-40.96	13.67	7.86	-19.43		
7520.00	H	-47.37	14.27	9.54	-23.56		
9400.00	H	---	---	---	---		
11280.00	H	---	---	---	---		
13160.00	H	---	---	---	---		
3760.00	Vertical	-34.39	15.81	6.12	-12.46	-13.00	Pass
5640.00	V	-39.00	13.80	7.86	-17.34		
7520.00	V	-44.40	13.40	9.54	-21.46		
9400.00	V	---	---	---	---		
11280.00	V	---	---	---	---		
13160.00	V	---	---	---	---		

Remark: 1, The testing has been conformed to  $10 \times 1880.0\text{MHz} = 18,800\text{MHz}$ .

2, All other emissions more than 30 dB below the limit.

3, Emission Level= Read Level+ Antenna Correct Factor +Cable Loss

Test mode: EDGE1900							
Channel: Middle		Date of Test: 2016-11-22					
Frequency (MHz)	Spurious Emission					Limit (dBm)	Result
	Polarization (H&V)	Read Level (dBm)	Antenna Correct Factor (dBi)	Cable Loss (dB)	Emission Level (dBm)		
3760.00	Horizontal	-39.16	14.70	6.12	-18.34	-13.00	Pass
5640.00	H	-44.17	13.67	7.86	-22.64		
7520.00	H	-50.26	14.27	9.54	-26.45		
9400.00	H	---	---	---	---		
11280.00	H	---	---	---	---		
13160.00	H	---	---	---	---		
3760.00	Vertical	-42.34	15.81	6.12	-20.41	-13.00	Pass
5640.00	V	-45.80	13.80	7.86	-24.14		
7520.00	V	-49.76	13.40	9.54	-26.82		
9400.00	V	---	---	---	---		
11280.00	V	---	---	---	---		
13160.00	V	---	---	---	---		

Remark: 1, The testing has been conformed to  $10 \times 1880.0\text{MHz} = 18,800\text{MHz}$ .  
 2, All other emissions more than 30 dB below the limit.  
 3, Emission Level= Read Level+ Antenna Correct Factor +Cable Loss

Test mode: UMTS Band V 12.2k RMC							
Channel: Middle		Date of Test: 2016-11-22					
Frequency (MHz)	Spurious Emission					Limit (dBm)	Result
	Polarization (H&V)	Read Level (dBm)	Antenna Correct Factor (dBi)	Cable Loss (dB)	Emission Level (dBm)		
1673.20	Horizontal	-29.65	7.49	3.97	-18.65	-13.00	Pass
2509.80	H	-39.96	7.03	5.05	-22.43		
3346.40	H	-43.72	12.48	5.98	-25.26		
4183.00	H	---	---	---	---		
5019.60	H	---	---	---	---		
5856.20	H	---	---	---	---		
1673.20	Vertical	-34.90	8.02	3.97	-20.46	-13.00	Pass
2509.80	V	-45.45	10.47	5.05	-23.48		
3346.40	V	-47.08	16.92	5.98	-26.06		
4183.00	V	---	---	---	---		
5019.60	V	---	---	---	---		
5856.20	V	---	---	---	---		
Test mode: UMTS Band V HSDPA							
Channel: Middle		Date of Test: 2016-11-22					
Frequency (MHz)	Spurious Emission					Limit (dBm)	Result
	Polarization (H&V)	Read Level (dBm)	Antenna Correct Factor (dBi)	Cable Loss (dB)	Emission Level (dBm)		
1673.20	Horizontal	-31.42	7.49	3.97	-20.42	-13.00	Pass
2509.80	H	-42.20	7.03	5.05	-24.67		
3346.40	H	-44.58	12.48	5.98	-26.12		
4183.00	H	---	---	---	---		
5019.60	H	---	---	---	---		
5856.20	H	---	---	---	---		
1673.20	Vertical	-34.11	8.02	3.97	-19.67	-13.00	Pass
2509.80	V	-46.09	10.47	5.05	-24.12		
3346.40	V	-48.08	16.92	5.98	-27.06		
4183.00	V	---	---	---	---		
5019.60	V	---	---	---	---		
5856.20	V	---	---	---	---		
Remark: 1, The testing has been conformed to $10 \times 836.6 \text{MHz} = 8,366 \text{MHz}$ . 2, All other emissions more than 30 dB below the limit. 3, Emission Level= Read Level+ Antenna Correct Factor +Cable Loss							

Test mode: UMTS Band V HSUPA							
Channel: Middle			Date of Test: 2016-11-22				
Frequency (MHz)	Spurious Emission					Limit (dBm)	Result
	Polarization (H&V)	Read Level (dBm)	Antenna Correct Factor (dBi)	Cable Loss (dB)	Emission Level (dBm)		
1673.20	Horizontal	-32.63	7.49	3.97	-21.63	-13.00	Pass
2509.80	H	-43.35	7.03	5.05	-25.82		
3346.40	H	-46.12	12.48	5.98	-27.66		
4183.00	H	---	---	---	---		
5019.60	H	---	---	---	---		
5856.20	H	---	---	---	---		
1673.20	Vertical	-35.12	8.02	3.97	-20.68	-13.00	Pass
2509.80	V	-46.64	10.47	5.05	-24.67		
3346.40	V	-50.48	16.92	5.98	-29.46		
4183.00	V	---	---	---	---		
5019.60	V	---	---	---	---		
5856.20	V	---	---	---	---		

Remark: 1, The testing has been conformed to  $10 \times 836.6\text{MHz} = 8,366\text{MHz}$ .  
 2, All other emissions more than 30 dB below the limit.  
 3, Emission Level= Read Level+ Antenna Correct Factor +Cable Loss

Test mode: UMTS Band II 12.2k RMC							
Channel: Middle		Date of Test: 2016-11-22					
Frequency (MHz)	Spurious Emission					Limit (dBm)	Result
	Polarization (H&V)	Read Level (dBm)	Antenna Correct Factor (dBi)	Cable Loss (dB)	Emission Level (dBm)		
3760.00	Horizontal	-37.25	14.70	6.12	-16.43	-13.00	Pass
5640.00	H	-41.95	13.67	7.86	-20.42		
7520.00	H	-49.12	14.27	9.54	-25.31		
9400.00	H	---	---	---	---		
11280.00	H	---	---	---	---		
13160.00	H	---	---	---	---		
3760.00	Vertical	-39.54	15.81	6.12	-17.61	-13.00	Pass
5640.00	V	-43.12	13.80	7.86	-21.46		
7520.00	V	-49.37	13.40	9.54	-26.43		
9400.00	V	---	---	---	---		
11280.00	V	---	---	---	---		
13160.00	V	---	---	---	---		

Test mode: UMTS Band II HSDPA							
Channel: Middle		Date of Test: 2016-11-22					
Frequency (MHz)	Spurious Emission					Limit (dBm)	Result
	Polarization (H&V)	Read Level (dBm)	Antenna Correct Factor (dBi)	Cable Loss (dB)	Emission Level (dBm)		
3760.00	Horizontal	-39.08	14.70	6.12	-18.26	-13.00	Pass
5640.00	H	-42.88	13.67	7.86	-21.35		
7520.00	H	-50.49	14.27	9.54	-26.68		
9400.00	H	---	---	---	---		
11280.00	H	---	---	---	---		
13160.00	H	---	---	---	---		
3760.00	Vertical	-41.61	15.81	6.12	-19.68	-13.00	Pass
5640.00	V	-44.14	13.80	7.86	-22.48		
7520.00	V	-50.36	13.40	9.54	-27.42		
9400.00	V	---	---	---	---		
11280.00	V	---	---	---	---		
13160.00	V	---	---	---	---		

Remark: 1, The testing has been conformed to  $10 \times 1880.0 \text{ MHz} = 18,800 \text{ MHz}$ .

2, All other emissions more than 30 dB below the limit.

3, Emission Level= Read Level+ Antenna Correct Factor +Cable Loss



Test mode: UMTS Band II HSUPA							
Channel: Middle		Date of Test: 2016-11-22					
Frequency (MHz)	Spurious Emission					Limit (dBm)	Result
	Polarization (H&V)	Read Level (dBm)	Antenna Correct Factor (dBi)	Cable Loss (dB)	Emission Level (dBm)		
3760.00	Horizontal	-39.49	14.70	6.12	-18.67	-13.00	Pass
5640.00	H	-45.18	13.67	7.86	-23.65		
7520.00	H	-51.30	14.27	9.54	-27.49		
9400.00	H	---	---	---	---		
11280.00	H	---	---	---	---		
13160.00	H	---	---	---	---		
3760.00	Vertical	-41.39	15.81	6.12	-19.46	-13.00	Pass
5640.00	V	-45.74	13.80	7.86	-24.08		
7520.00	V	-47.91	13.40	9.54	-24.97		
9400.00	V	---	---	---	---		
11280.00	V	---	---	---	---		
13160.00	V	---	---	---	---		

Remark: 1, The testing has been conformed to  $10 \times 1880.0\text{MHz} = 18,800\text{MHz}$ .  
 2, All other emissions more than 30 dB below the limit.  
 3, Emission Level= Read Level+ Antenna Correct Factor +Cable Loss

-----End of Report-----