

FCC Test Report

Product Name	Wireless Receiver
Model No.	ENY-R1U02W, ENY-P1U01W
FCC ID.	2AJ8N-ENY-P1U01W

Applicant	Quantum Inc.
Address	1-13-10 Shibaura, Minato-ku, Tokyo 105-0023, Japan

Date of Receipt	Mar. 06, 2017
Issued Date	Mar. 16, 2017
Report No.	1730110R-RFUSP15V00
Report Version	V1.0



The test results relate only to the samples tested.

The test results shown in the test report are traceable to the national/international standard through the calibration report of the equipment and evaluated measurement uncertainty herein.

This report must not be used to claim product endorsement by TAF or any agency of the government.

The test report shall not be reproduced without the written approval of DEKRA Testing and Certification Co., Ltd.

Test Report

Issued Date: Mar. 16, 2017

Report No.: 1730110R-RFUSP15V00



Product Name	Wireless Receiver
Applicant	Quantum Inc.
Address	1-13-10 Shibaura, Minato-ku, Tokyo 105-0023, Japan
Manufacturer	Panasonic Corporation
Model No.	ENY-R1U02W, ENY-P1U01W
FCC ID.	2AJ8N-ENY-P1U01W
EUT Rated Voltage	DC 5V (Power by USB)
EUT Test Voltage	DC 5V (Power by USB)
Trade Name	Quantum
Applicable Standard	FCC CFR Title 47 Part 15 Subpart C: 2015 ANSI C63.4: 2014, ANSI C63.10: 2013 KDB 558074 D01 DTS Meas Guidance v03r05
Test Result	Complied

Documented By : Genie Chang
(Senior Adm. Specialist / Genie Chang)

Tested By : Nick Chen
(Engineer / Nick Chen)

Approved By : Vincent Lin
(Director / Vincent Lin)

TABLE OF CONTENTS

Description	Page
1. GENERAL INFORMATION	4
1.1. EUT Description.....	4
1.2. Operational Description.....	6
1.3. Tested System Details.....	7
1.4. Configuration of Tested System	7
1.5. EUT Exercise Software	7
1.6. Test Facility	8
1.7. List of Test Equipment.....	9
2. CONDUCTED EMISSION	10
2.1. Test Setup	10
2.2. Limits.....	10
2.3. Test Procedure	11
2.4. Uncertainty	11
2.5. Test Result of Conducted Emission.....	12
3. PEAK POWER OUTPUT	16
3.1. Test Setup	16
3.2. Limit	16
3.3. Test Procedure	16
3.4. Uncertainty	16
3.5. Test Result of Peak Power Output.....	17
4. RADIATED EMISSION	19
4.1. Test Setup	19
4.2. Limits.....	20
4.3. Test Procedure	21
4.4. Uncertainty	21
4.5. Test Result of Radiated Emission.....	22
5. RF ANTENNA CONDUCTED TEST	28
5.1. Test Setup	28
5.2. Limits.....	28
5.3. Test Procedure	28
5.4. Uncertainty	28
5.5. Test Result of RF Antenna Conducted Test.....	29
6. BAND EDGE	31
6.1. Test Setup	31
6.2. Limit	32
6.3. Test Procedure	32
6.4. Uncertainty	32
6.5. Test Result of Band Edge	33
7. 6DB BANDWIDTH	41
7.1. Test Setup	41
7.2. Limits.....	41
7.3. Test Procedure	41
7.4. Uncertainty	41
7.5. Test Result of 6dB Bandwidth.....	42
8. POWER DENSITY	46
8.1. Test Setup	46
8.2. Limits.....	46
8.3. Test Procedure	46
8.4. Uncertainty	46
8.5. Test Result of Power Density	47
9. EMI REDUCTION METHOD DURING COMPLIANCE TESTING	51
Attachment 1: EUT Test Photographs	
Attachment 2: EUT Detailed Photographs	

1. GENERAL INFORMATION

1.1. EUT Description

Product Name	Wireless Receiver
Trade Name	Quantum
Model No.	ENY-R1U02W, ENY-P1U01W
FCC ID.	2AJ8N-ENY-P1U01W
Frequency Range	2402-2478MHz
Channel Number	2
Type of Modulation	GFSK
Antenna Type	inverted F
Channel Control	Auto
Antenna Gain	Refer to the table “Antenna List”

Antenna List

No.	Manufacturer	Part No.	Antenna Type	Peak Gain
1	Taiyo Yuden	AH083F245001-T	inverted F	1.8dBi for 2.4 GHz

Note: The antenna of EUT is conforming to FCC 15.203.

Center Frequency of Each Channel

Channel	Frequency	Channel	Frequency
Channel 01:	2402 MHz	Channel 02:	2478 MHz

Note:

1. The EUT is a Wireless Receiver with a built-in 2.4GHz wireless transceiver.
2. The EUT is including two models for different marketing requirement.
3. These tests were conducted on a sample for the purpose of demonstrating compliance of Bluetooth transmitter with Part 15 Subpart C Paragraph 15.247 for spread spectrum devices.
4. The radiation measurements are performed in X, Y, Z axis positioning. Only the worst case is shown in the report.
5. The EUT has two sets of independent transceiver functions and shown in the report.

Test Mode	Mode 1: Transmit (Antenna: 0) Mode 2: Transmit (Antenna: 1)
-----------	--

1.2. Operational Description

The EUT is Wireless Receiver with a built-in 2.4GHz transceiver. Total numbers of channels supported by this device are 2 channels. Operating channels are 2402MHz and 2478MHz. The antenna type is inverted F and the modulation type is GFSK. The device can receive wireless signal and transmit signal for associate device. This device has two sets of independent transceiver functions which can not transmit signals simultaneously

1.3. Tested System Details

The types for all equipment, plus descriptions of all cables used in the tested system (including inserted cards) are:

	Product	Manufacturer	Model No.	Serial No.	Power Cord
1	Notebook PC	DELL	P62G	229FJC2	Non-Shielded, 1.8m

	Signal Cable Type	Signal cable Description
A	USB Cable	Shielded, 1.8m

1.4. Configuration of Tested System

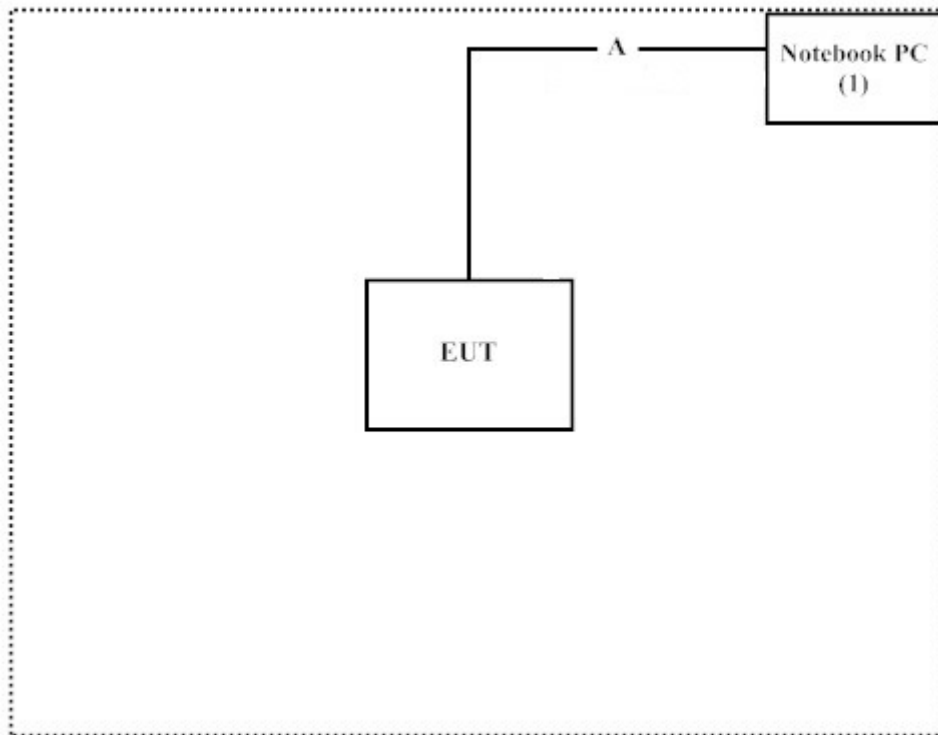

1.5. EUT Exercise Software

- (1) Setup the EUT as shown in Section 1.4.
- (2) Execute software “Tera Term (ver 4.90)” on the Notebook.
- (3) Configure the test mode, the test channel, and the data rate.
- (4) Press “OK” to start the continuous Transmit.
- (5) Verify that the EUT works properly.

1.6. Test Facility

Ambient conditions in the laboratory:

Items	Required (IEC 68-1)	Actual
Temperature (°C)	15-35	20-35
Humidity (%RH)	25-75	50-65
Barometric pressure (mbar)	860-1060	950-1000

The related certificate for our laboratories about the test site and management system can be downloaded from DEKRA Testing and Certification Co., Ltd. Web Site:

<http://www.dekra.com.tw/english/about/certificates.aspx?bval=5>

The address and introduction of DEKRA Testing and Certification Co., Ltd. laboratories can be founded in our Web site: http://www.dekra.com.tw/index_en

Site Description: File on
 Federal Communications Commission
 FCC Engineering Laboratory
 7435 Oakland Mills Road
 Columbia, MD 21046
 Registration Number: 92195

Site Name: DEKRA Testing and Certification Co., Ltd.
 Site Address: No.159, Sec. 2, Wenhua 1st Rd., Linkou Dist.,
 New Taipei City 24457, Taiwan.
 TEL: 886-2-2602-7968 / FAX : 866-2-2602-3286
 E-Mail : info.tw@dekra.com

FCC Accreditation Number: TW1014

1.7. List of Test Equipment

For Conduction measurements /ASR1

	Equipment	Manufacturer	Model No.	Serial No.	Cali. Data	Due. Data
X	EMI Test Receiver	R&S	ESR7	161601	2017.01.04	2018.01.05
X	LISN	R&S	ESH3-Z5	836679/017	2017.01.18	2018.01.17
X	LISN	R&S	ENV216	100097	2017.01.18	2018.01.17
X	Coaxial Cable	Quietek	RG400_BNC	RF001	2016.05.25	2017.05.24

Note:

1. All equipments are calibrated every one year.
2. The test instruments marked with "X" are used to measure the final test results.
3. Test Software version : QuieTek EMI 2.0 V2.1.113

For Conducted measurements /ASR4

	Equipment	Manufacturer	Model No.	Serial No.	Cali. Data	Due. Data
X	Spectrum Analyzer	R&S	FSV30	103464	2017.01.07	2018.01.08
X	Power Meter	Anritsu	ML2496A	1548003	2016.12.15	2017.12.14
X	Power Sensor	Anritsu	MA2411B	1531024	2016.12.15	2017.12.14
X	Power Sensor	Anritsu	MA2411B	1531025	2016.12.15	2017.12.14
	Bluetooth Tester	R&S	CBT	101238	2017.01.01	2018.01.02

Note:

1. All equipments are calibrated every one year.
2. The test instruments marked with "X" are used to measure the final test results.
3. Test Software version : QuieTek Conduction Test System V8.0.110

For Radiated measurements /ACB1

	Equipment	Manufacturer	Model No.	Serial No.	Cali. Data	Due. Data
X	Loop Antenna	A.H.	SAS-562B	272	2016.07.21	2017.07.20
X	Bi-Log Antenna	SCHWARZBECK	VULB9168	9168-675	2016.05.06	2017.05.05
X	Horn Antenna	ETS-Lindgren	3117	00203800	2016.10.13	2017.10.12
X	Horn Antenna	Com-Power	AH-840	101087	2016.05.03	2017.05.02
X	Pre-Amplifier	EMCI	EMC001330	980316	2016.04.27	2017.04.26
X	Pre-Amplifier	EMCI	EMC051835SE	980311	2016.04.27	2017.04.26
X	Pre-Amplifier	EMCI	EMC05820SE	980310	2016.04.28	2017.04.27
X	Pre-Amplifier	EMCI	EMC184045SE	980314	2016.05.12	2017.05.11
X	Filter	MICRO TRONICS	BRM50702	G251	2016.08.11	2017.08.10
	Filter	MICRO TRONICS	BRM50716	G188	2016.08.11	2017.08.10
X	EMI Test Receiver	R&S	ESR7	101602	2016.12.15	2017.12.14
X	Spectrum Analyzer	R&S	FSV40	101149	2016.12.14	2017.12.13
X	Coaxial Cable	SUHNER	SUCOFLEX 106	RF002	2016.05.25	2017.05.24
X	Mircoflex Cable	HUBER SUHNER	SUCOFLEX 102	MY3381/2	2016.08.11	2017.08.10

Note:

1. All equipments are calibrated every one year.
2. The test instruments marked with "X" are used to measure the final test results.
3. Test Software version : QuieTek EMI 2.0 V2.1.113

2. Conducted Emission

2.1. Test Setup

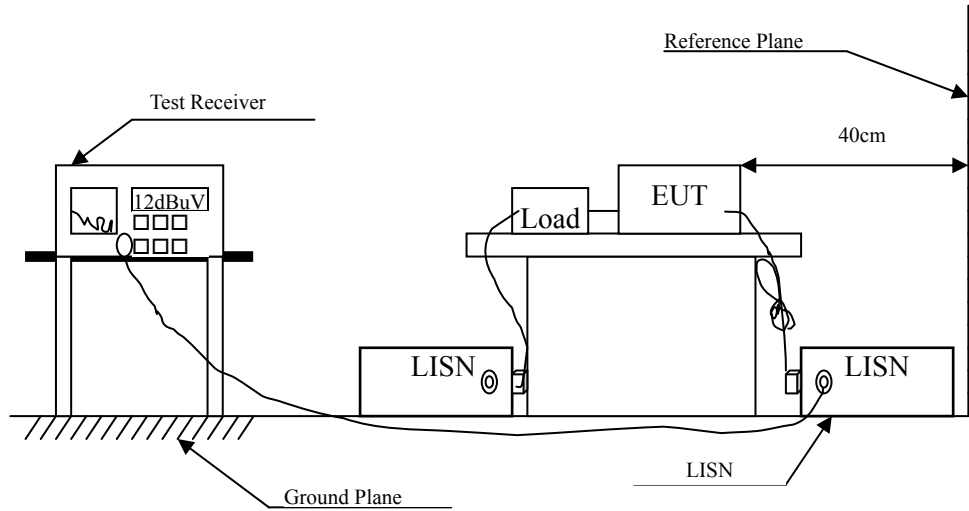

2.2. Limits

FCC Part 15 Subpart C Paragraph 15.207 (dBuV) Limit		
Frequency MHz	Limits	
	QP	AV
0.15 - 0.50	66-56	56-46
0.50-5.0	56	46
5.0 - 30	60	50

Remarks: In the above table, the tighter limit applies at the band edges.

2.3. Test Procedure

The EUT and Peripherals are connected to the main power through a line impedance stabilization network (L.I.S.N.). This provides a 50 ohm /50uH coupling impedance for the measuring equipment. The peripheral devices are also connected to the main power through a LISN that provides a 50ohm /50uH coupling impedance with 50ohm termination. (Please refer to the block diagram of the test setup and photographs.)

Both sides of A.C. line are checked for maximum conducted interference. In order to find the maximum emission, the relative positions of equipment and all the interface cables must be changed according to ANSI C63.4: 2014 on conducted measurement.

Conducted emissions were investigated over the frequency range from 0.15MHz to 30MHz using a receiver bandwidth of 9kHz.

The EUT was setup to ANSI C63.4, 2014; tested to DTS test procedure of FCC KDB-558074 for compliance to FCC 47CFR Subpart C requirements.

2.4. Uncertainty

±2.35dB

2.5. Test Result of Conducted Emission

Product : Wireless Receiver
 Test Item : Conducted Emission Test
 Power Line : Line 1
 Test Date : 2017/03/07
 Test Mode : Mode 1: Transmit (Antenna: 0) (2402MHz)

Frequency MHz	Correct Factor dB	Reading Level dB μ V	Measurement Level dB μ V	Margin dB	Limit dB μ V
LINE 1					
Quasi-Peak					
0.154	9.707	36.018	45.725	-20.161	65.886
0.487	9.735	25.198	34.933	-21.438	56.371
2.742	9.819	17.624	27.443	-28.557	56.000
3.617	9.854	22.498	32.351	-23.649	56.000
9.764	9.996	18.899	28.894	-31.106	60.000
24.576	10.172	19.582	29.754	-30.246	60.000
Average					
0.154	9.707	20.132	29.838	-26.048	55.886
0.487	9.735	17.493	27.229	-19.142	46.371
2.742	9.819	11.277	21.096	-24.904	46.000
3.617	9.854	10.675	20.528	-25.472	46.000
9.764	9.996	14.560	24.555	-25.445	50.000
24.576	10.172	19.233	29.405	-20.595	50.000

Note:

1. All Reading Levels are Quasi-Peak and average value.
2. "█" means the worst emission level.
3. Measurement Level = Reading Level + Correct Factor

Product : Wireless Receiver
 Test Item : Conducted Emission Test
 Power Line : Line 2
 Test Date : 2017/03/07
 Test Mode : Mode 1: Transmit (Antenna: 0) (2402MHz)

Frequency MHz	Correct Factor dB	Reading Level dB μ V	Measurement Level dB μ V	Margin dB	Limit dB μ V
LINE 2					
Quasi-Peak					
0.152	9.698	36.504	46.202	-19.741	65.943
0.481	9.725	21.895	31.620	-24.923	56.543
3.628	9.854	20.843	30.697	-25.303	56.000
10.162	10.003	12.180	22.183	-37.817	60.000
18.244	10.138	7.281	17.418	-42.582	60.000
24.576	10.212	20.339	30.551	-29.449	60.000
Average					
0.152	9.698	20.346	30.044	-25.899	55.943
0.481	9.725	15.455	25.180	-21.363	46.543
3.628	9.854	11.184	21.039	-24.961	46.000
10.162	10.003	8.328	18.330	-31.670	50.000
18.244	10.138	3.408	13.546	-36.454	50.000
24.576	10.212	19.718	29.930	-20.070	50.000

Note:

1. All Reading Levels are Quasi-Peak and average value.
2. "█" means the worst emission level.
3. Measurement Level = Reading Level + Correct Factor

Product : Wireless Receiver
 Test Item : Conducted Emission Test
 Power Line : Line 1
 Test Date : 2017/03/07
 Test Mode : Mode 2: Transmit (Antenna: 1) (2402MHz)

Frequency MHz	Correct Factor dB	Reading Level dB μ V	Measurement Level dB μ V	Margin dB	Limit dB μ V
LINE 1					
Quasi-Peak					
0.150	9.708	36.625	46.333	-19.667	66.000
0.490	9.736	25.522	35.258	-21.028	56.286
2.695	9.820	16.601	26.421	-29.579	56.000
3.604	9.853	21.570	31.423	-24.577	56.000
9.674	9.986	18.055	28.041	-31.959	60.000
24.576	10.172	19.859	30.031	-29.969	60.000
Average					
0.150	9.708	19.719	29.427	-26.573	56.000
0.490	9.736	17.682	27.418	-18.868	46.286
2.695	9.820	10.780	20.599	-25.401	46.000
3.604	9.853	10.606	20.458	-25.542	46.000
9.674	9.986	14.087	24.073	-25.927	50.000
24.576	10.172	19.253	29.425	-20.575	50.000

Note:

1. All Reading Levels are Quasi-Peak and average value.
2. "█" means the worst emission level.
3. Measurement Level = Reading Level + Correct Factor

Product : Wireless Receiver
 Test Item : Conducted Emission Test
 Power Line : Line 2
 Test Date : 2017/03/07
 Test Mode : Mode 2: Transmit (Antenna: 1) (2402MHz)

Frequency MHz	Correct Factor dB	Reading Level dB μ V	Measurement Level dB μ V	Margin dB	Limit dB μ V
LINE 2					
Quasi-Peak					
0.159	9.697	35.920	45.616	-20.127	65.743
0.490	9.727	22.815	32.542	-23.744	56.286
3.590	9.852	19.578	29.429	-26.571	56.000
10.066	9.986	12.381	22.367	-37.633	60.000
18.251	10.139	6.289	16.428	-43.572	60.000
24.576	10.212	20.263	30.475	-29.525	60.000
Average					
0.159	9.697	19.723	29.419	-26.324	55.743
0.490	9.727	16.423	26.150	-20.136	46.286
3.590	9.852	10.356	20.208	-25.792	46.000
10.066	9.986	8.276	18.262	-31.738	50.000
18.251	10.139	1.500	11.639	-38.361	50.000
24.576	10.212	19.541	29.753	-20.247	50.000

Note:

1. All Reading Levels are Quasi-Peak and average value.
2. "█" means the worst emission level.
3. Measurement Level = Reading Level + Correct Factor

3. Peak Power Output

3.1. Test Setup

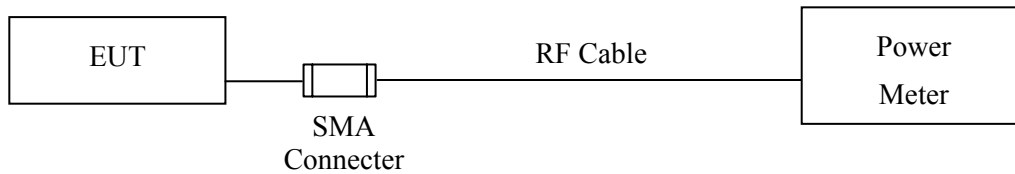

3.2. Limit

The maximum peak power shall be less 1Watt.

3.3. Test Procedure

Tested according to DTS test procedure of KDB 558074 for compliance to FCC 47CFR 15.247 requirements. The maximum peak conducted output power using KDB 558074 section 9.1.2 PKPM1 Peak power meter method.

3.4. Uncertainty

± 0.86 dB

3.5. Test Result of Peak Power Output

Product : Wireless Receiver
Test Item : Peak Power Output
Test Mode : Mode 1: Transmit (Antenna: 0)
Test Date : 2017/03/16

Channel No.	Frequency (MHz)	Measurement (dBm)	Required Limit	Result
Channel 01	2402.00	-5.39	1 Watt= 30 dBm	Pass
Channel 02	2478.00	-4.25	1 Watt= 30 dBm	Pass

Product : Wireless Receiver
Test Item : Peak Power Output
Test Mode : Mode 2: Transmit (Antenna: 1)
Test Date : 2017/03/16

Channel No.	Frequency (MHz)	Measurement (dBm)	Required Limit	Result
Channel 01	2402.00	-5.55	1 Watt= 30 dBm	Pass
Channel 02	2478.00	-4.46	1 Watt= 30 dBm	Pass

4. Radiated Emission

4.1. Test Setup

Radiated Emission Under 30MHz

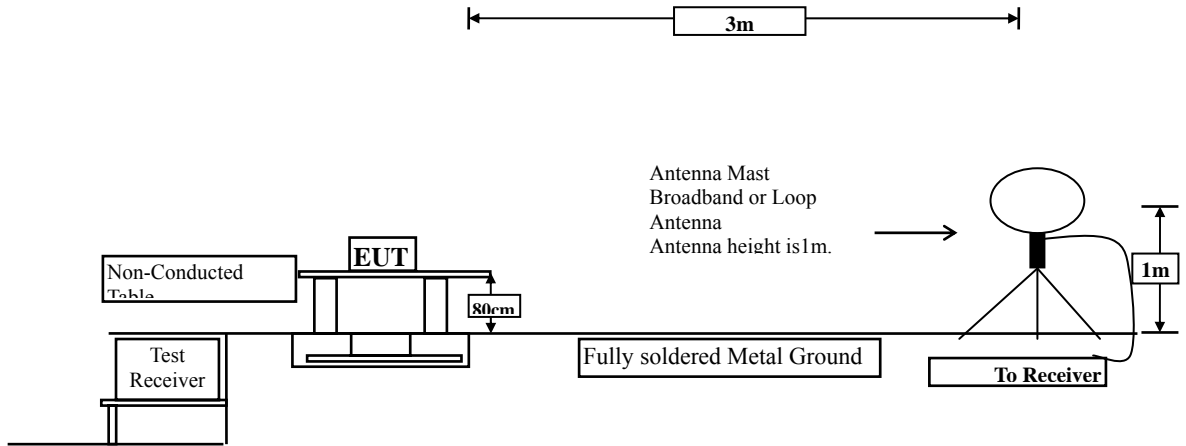

Radiated Emission Below 1GHz

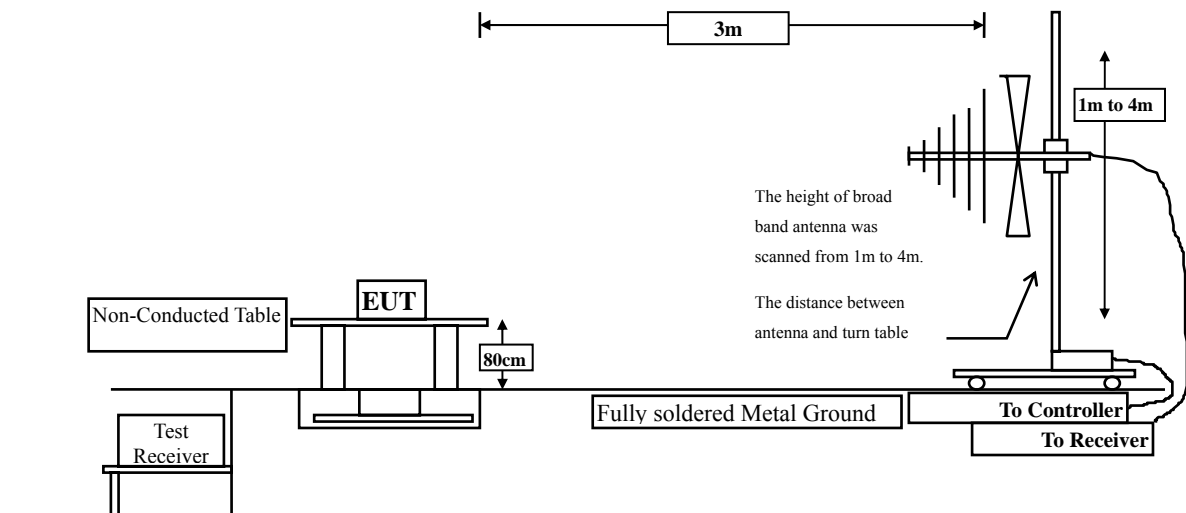

Radiated Emission Above 1GHz

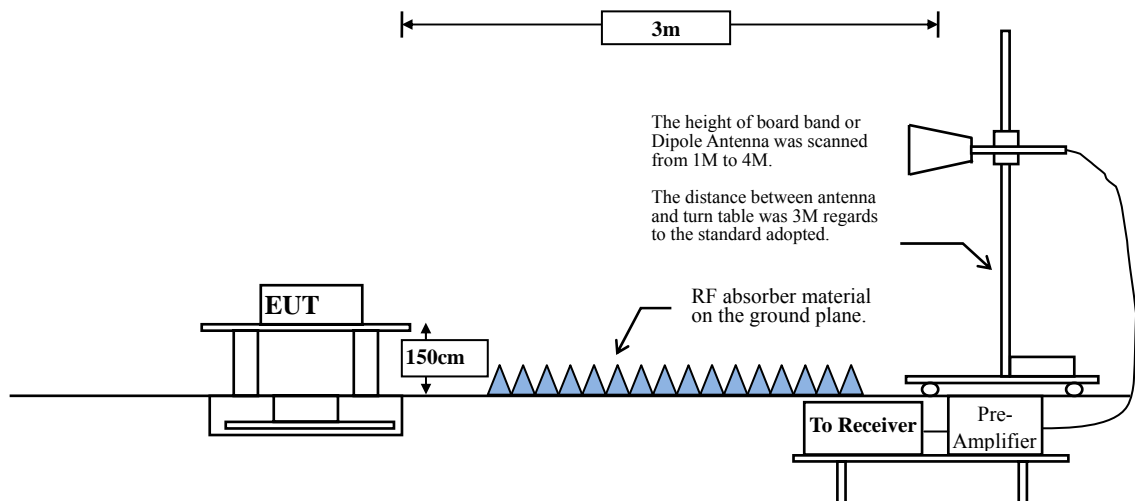

4.2. Limits

➤ General Radiated Emission Limits

Emissions radiated outside of the specified frequency bands, except for harmonics, shall be attenuated by at least 20dB below the level of the fundamental or to the general radiated emission limits in paragraph 15.209, whichever is the lesser attenuation.

FCC Part 15 Subpart C Paragraph 15.209 Limits		
Frequency MHz	Field strength (microvolts/meter)	Measurement distance (meter)
0.009-0.490	2400/F(kHz)	300
0.490-1.705	24000/F(kHz)	30
1.705-30	30	30
30-88	100	3
88-216	150	3
216-960	200	3
Above 960	500	3

- Remarks:
1. RF Voltage (dBuV) = 20 log RF Voltage (uV)
 2. In the Above Table, the tighter limit applies at the band edges.
 3. Distance refers to the distance in meters between the measuring instrument antenna and the closed point of any part of the device or system.

4.3. Test Procedure

The EUT was setup according to ANSI C63.10: 2013 and tested according to DTS test procedure of KDB558074 for compliance to FCC 47CFR 15.247 requirements.

Measuring the frequency range below 1GHz, the EUT is placed on a turn table which is 0.8 meter above ground, when measuring the frequency range above 1GHz, the EUT is placed on a turn table which is 1.5 meter above ground.

The turn table is rotated 360 degrees to determine the position of the maximum emission level.

The EUT was positioned such that the distance from antenna to the EUT was 3 meters.

The antenna is scanned between 1 meter and 4 meters to find out the maximum emission level. This is repeated for both horizontal and vertical polarization of the antenna. In order to find the maximum emission, all of the interface cables were manipulated according to ANSI C63.10: 2013 on radiated measurement.

The resolution bandwidth below 30MHz setting on the field strength meter is 9kHz and 30MHz~1GHz is 120kHz and above 1GHz is 1MHz.

Radiated emission measurements below 30MHz are made using Loop Antenna and 30MHz~1GHz are made using broadband Bilog antenna and above 1GHz are made using Horn Antennas.

The measurement is divided into the Preliminary Measurement and the Final Measurement.

The suspected frequencies are searched for in Preliminary Measurement with the measurement antenna kept pointed at the source of the emission both in azimuth and elevation, with the polarization of the antenna oriented for maximum response. The antenna is pointed at an angle towards the source of the emission, and the EUT is rotated in both height and polarization to maximize the measured emission. The emission is kept within the illumination area of the 3 dB bandwidth of the antenna.

The measurement frequency range from 9kHz - 10th Harmonic of fundamental was investigated.

4.4. Uncertainty

Horizontal polarization :

30-300MHz: ± 4.08 dB ; 300M-1GHz: ± 3.86 dB ; 1-18GHz: ± 3.77 dB ; 18-40GHz: ± 3.98 dB

Vertical polarization :

30-300MHz: ± 4.81 dB ; 300M-1GHz: ± 3.87 dB ; 1-18GHz : ± 3.83 dB ; 18-40GHz: ± 3.98 dB

4.5. Test Result of Radiated Emission

Product : Wireless Receiver
 Test Item : Harmonic Radiated Emission Data
 Test Date : 2017/03/07
 Test Mode : Mode 1: Transmit (Antenna: 0) (2402MHz)

Frequency MHz	Correct Factor dB	Reading Level dB μ V	Measurement Level dB μ V /m	Margin dB	Limit dB μ V /m
Horizontal					
Peak Detector:					
4804.000	-6.116	56.710	50.594	-23.406	74.000
7206.000	-3.104	39.300	36.197	-37.803	74.000
9608.000	-0.688	38.270	37.583	-36.417	74.000
Average Detector:					
--					54.000
Vertical					
Peak Detector:					
4804.000	-6.116	54.540	48.424	-25.576	74.000
7206.000	-3.104	52.340	49.237	-24.763	74.000
9608.000	-0.688	42.890	42.203	-31.797	74.000
Average Detector:					
--					54.000

Note:

1. All Readings below 1GHz are Quasi-Peak, above 1GHz are performed with peak and/or average measurements as necessary.
2. Peak measurements: RBW = 1MHz, VBW = 3 MHz, Sweep: Auto.
3. Average measurements: RBW = 1MHz, VBW = 10 Hz, Sweep: Auto.
4. Measurement Level = Reading Level + Correct Factor.
5. Correct Factor = Antenna factor + Cable loss – Amplifier gain.
6. The average measurement was not performed when the peak measured data under the limit of average detection.
7. The emission levels of other frequencies are very lower than the limit and not show in test report.

Product : Wireless Receiver
 Test Item : Harmonic Radiated Emission Data
 Test Date : 2017/03/07
 Test Mode : Mode 1: Transmit (Antenna: 0) (2478MHz)

Frequency MHz	Correct Factor dB	Reading Level dB μ V	Measurement Level dB μ V /m	Margin dB	Peak Limit dB μ V /m
Horizontal					
Peak Detector:					
4956.000	-6.057	52.900	46.843	-27.157	74.000
7434.000	-2.878	48.630	45.752	-28.248	74.000
9912.000	-0.330	34.920	34.590	-39.410	74.000
Average Detector					
--					
Vertical					
Peak Detector:					
4956.000	-6.057	54.140	48.083	-25.917	74.000
7434.000	-2.878	46.110	43.232	-30.768	74.000
9912.000	-0.330	38.160	37.830	-36.170	74.000
Average Detector					
--					
					54.000

Note:

1. All Readings below 1GHz are Quasi-Peak, above 1GHz are performed with peak and/or average measurements as necessary.
2. Peak measurements: RBW = 1MHz, VBW = 3 MHz, Sweep: Auto.
3. Average measurements: RBW = 1MHz, VBW = 10 Hz, Sweep: Auto.
4. Measurement Level = Reading Level + Correct Factor.
5. Correct Factor = Antenna factor + Cable loss – Amplifier gain.
6. The average measurement was not performed when the peak measured data under the limit of average detection.
7. The emission levels of other frequencies are very lower than the limit and not show in test report.

Product : Wireless Receiver
 Test Item : Harmonic Radiated Emission Data
 Test Date : 2017/03/07
 Test Mode : Mode 2: Transmit (Antenna: 1) (2402MHz)

Frequency MHz	Correct Factor dB	Reading Level dB μ V	Measurement Level dB μ V /m	Margin dB	Peak Limit dB μ V /m
Horizontal					
Peak Detector:					
4804.000	-6.116	58.230	52.114	-21.886	74.000
7206.000	-3.104	51.370	48.267	-25.733	74.000
9608.000	-0.688	39.280	38.593	-35.407	74.000
Average Detector					
--					54.000
Vertical					
Peak Detector:					
4804.000	-6.116	57.190	51.074	-22.926	74.000
7206.000	-3.104	52.880	49.777	-24.223	74.000
9608.000	-0.688	37.840	37.153	-36.847	74.000
Average Detector					
--					54.000

Note:

1. All Readings below 1GHz are Quasi-Peak, above 1GHz are performed with peak and/or average measurements as necessary.
2. Peak measurements: RBW = 1MHz, VBW = 3 MHz, Sweep: Auto.
3. Average measurements: RBW = 1MHz, VBW = 10 Hz, Sweep: Auto.
4. Measurement Level = Reading Level + Correct Factor.
5. Correct Factor = Antenna factor + Cable loss – Amplifier gain.
6. The average measurement was not performed when the peak measured data under the limit of average detection.
7. The emission levels of other frequencies are very lower than the limit and not show in test report.

Product : Wireless Receiver
 Test Item : Harmonic Radiated Emission Data
 Test Date : 2017/03/07
 Test Mode : Mode 2: Transmit (Antenna: 1) (2478MHz)

Frequency MHz	Correct Factor dB	Reading Level dB μ V	Measurement Level dB μ V /m	Margin dB	Peak Limit dB μ V /m
Horizontal					
Peak Detector:					
4956.000	-6.057	59.810	53.753	-20.247	74.000
7434.000	-2.878	43.940	41.062	-32.938	74.000
9912.000	-0.330	35.620	35.290	-38.710	74.000
Average Detector					
--					54.000
Vertical					
Peak Detector:					
4956.000	-6.057	59.640	53.583	-20.417	74.000
7434.000	-2.878	52.130	49.252	-24.748	74.000
9912.000	-0.330	35.840	35.510	-38.490	74.000
Average Detector					
--					54.000

Note:

1. All Readings below 1GHz are Quasi-Peak, above 1GHz are performed with peak and/or average measurements as necessary.
2. Peak measurements: RBW = 1MHz, VBW = 3 MHz, Sweep: Auto.
3. Average measurements: RBW = 1MHz, VBW = 10 Hz, Sweep: Auto.
4. Measurement Level = Reading Level + Correct Factor.
5. Correct Factor = Antenna factor + Cable loss – Amplifier gain.
6. The average measurement was not performed when the peak measured data under the limit of average detection.
7. The emission levels of other frequencies are very lower than the limit and not show in test report.

Product : Wireless Receiver
 Test Item : General Radiated Emission Data
 Test Date : 2017/03/07
 Test Mode : Mode 1: Transmit (Antenna: 0) (2402MHz)

Frequency MHz	Correct Factor dB	Reading Level dB μ V	Measurement Level dB μ V /m	Margin dB	Limit dB μ V /m
Horizontal					
62.333	-12.480	40.666	28.186	-11.814	40.000
110.130	-14.382	49.729	35.348	-8.152	43.500
146.681	-11.214	41.180	29.967	-13.533	43.500
472.826	-6.473	32.309	25.837	-20.163	46.000
773.667	-1.915	30.540	28.625	-17.375	46.000
932.522	0.032	29.966	29.999	-16.001	46.000
Vertical					
49.681	-10.906	47.044	36.138	-3.862	40.000
157.928	-10.906	38.110	27.204	-16.296	43.500
311.159	-10.098	35.524	25.426	-20.574	46.000
433.464	-7.256	33.292	26.037	-19.963	46.000
773.667	-1.915	30.343	28.428	-17.572	46.000
938.145	0.091	29.930	30.021	-15.979	46.000

Note:

1. All Readings below 1GHz are Quasi-Peak, above 1GHz are performed with peak and/or average measurements as necessary.
2. Peak measurements: RBW = 1MHz, VBW = 3 MHz, Sweep: Auto.
3. Average measurements: RBW = 1MHz, VBW = 10 Hz, Sweep: Auto.
4. Measurement Level = Reading Level + Correct Factor.
5. Correct Factor = Antenna factor + Cable loss – Amplifier gain.
6. The average measurement was not performed when the peak measured data under the limit of average detection.
7. The emission levels of other frequencies are very lower than the limit and not show in test report.
8. No emission found between lowest internal used/generated frequency to 30MHz.

Product : Wireless Receiver
 Test Item : General Radiated Emission Data
 Test Date : 2017/03/07
 Test Mode : Mode 2: Transmit (Antenna: 1) (2402MHz)

Frequency MHz	Correct Factor dB	Reading Level dB μ V	Measurement Level dB μ V /m	Margin dB	Limit dB μ V /m
Horizontal					
108.725	-14.603	51.369	36.767	-6.733	43.500
160.739	-10.884	42.653	31.770	-11.730	43.500
311.159	-10.098	35.385	25.287	-20.713	46.000
432.058	-7.289	34.134	26.845	-19.155	46.000
773.667	-1.915	30.124	28.209	-17.791	46.000
938.145	0.091	29.819	29.910	-16.090	46.000
Vertical					
108.725	-14.603	51.369	36.767	-6.733	43.500
160.739	-10.884	42.653	31.770	-11.730	43.500
311.159	-10.098	35.385	25.287	-20.713	46.000
432.058	-7.289	34.134	26.845	-19.155	46.000
773.667	-1.915	30.639	28.724	-17.276	46.000
938.145	0.091	29.819	29.910	-16.090	46.000

Note:

1. All Readings below 1GHz are Quasi-Peak, above 1GHz are performed with peak and/or average measurements as necessary.
2. Peak measurements: RBW = 1MHz, VBW = 3 MHz, Sweep: Auto.
3. Average measurements: RBW = 1MHz, VBW = 10 Hz, Sweep: Auto.
4. Measurement Level = Reading Level + Correct Factor.
5. Correct Factor = Antenna factor + Cable loss – Amplifier gain.
6. The average measurement was not performed when the peak measured data under the limit of average detection.
7. The emission levels of other frequencies are very lower than the limit and not show in test report.
8. No emission found between lowest internal used/generated frequency to 30MHz.

5. RF Antenna Conducted Test

5.1. Test Setup

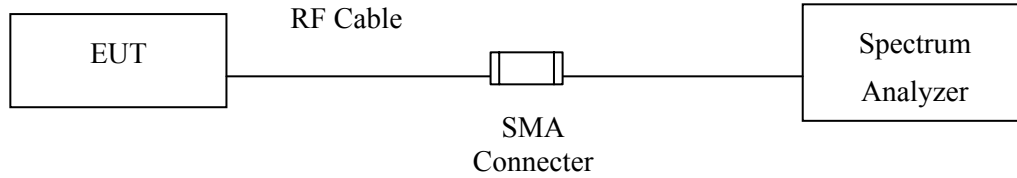

5.2. Limits

According to FCC Section 15.247(d). In any 100 kHz bandwidth outside the frequency band in which the spread spectrum or digitally modulated intentional radiator is operating, the radio frequency power that is produced by the intentional radiator shall be at least 20 dB below that in the 100 kHz bandwidth within the band that contains the highest level of the desired power, based on either an RF conducted or measurement, provided the transmitter demonstrates compliance with the peak conducted power limits. If the transmitter complies with the conducted power limits based on the use of RMS averaging over a time interval, the attenuation required under this paragraph shall be 30 dB instead of 20 dB.

5.3. Test Procedure

The EUT was tested according to DTS test procedure of KDB558074 for compliance to FCC 47CFR 15.247 requirements.

Set RBW = 100 kHz, Set VBW > RBW, scan up through 10th harmonic.

5.4. Uncertainty

±1.23dB

5.5. Test Result of RF Antenna Conducted Test

Product : Wireless Receiver
 Test Item : RF Antenna Conducted Test
 Test Mode : Mode 1: Transmit (Antenna: 0)
 Test Date : 2017/03/16

Figure Channel 01:

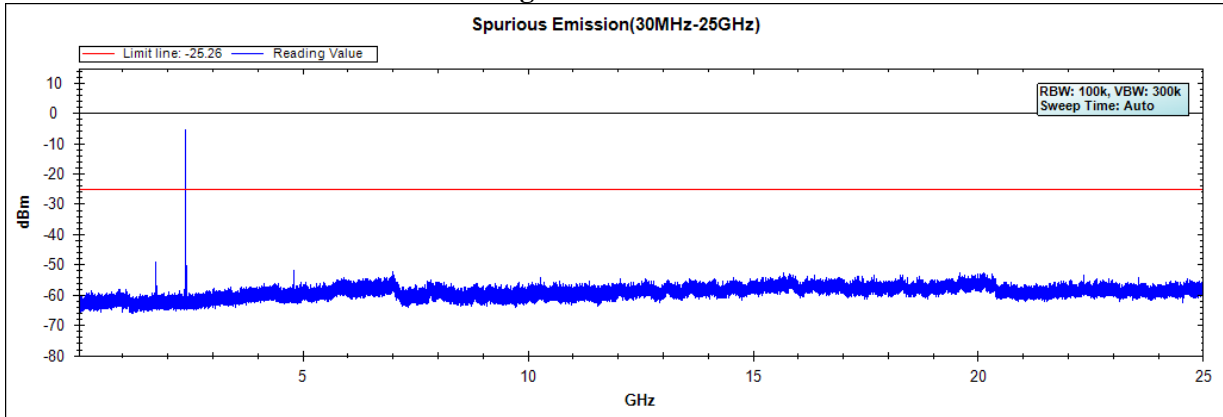
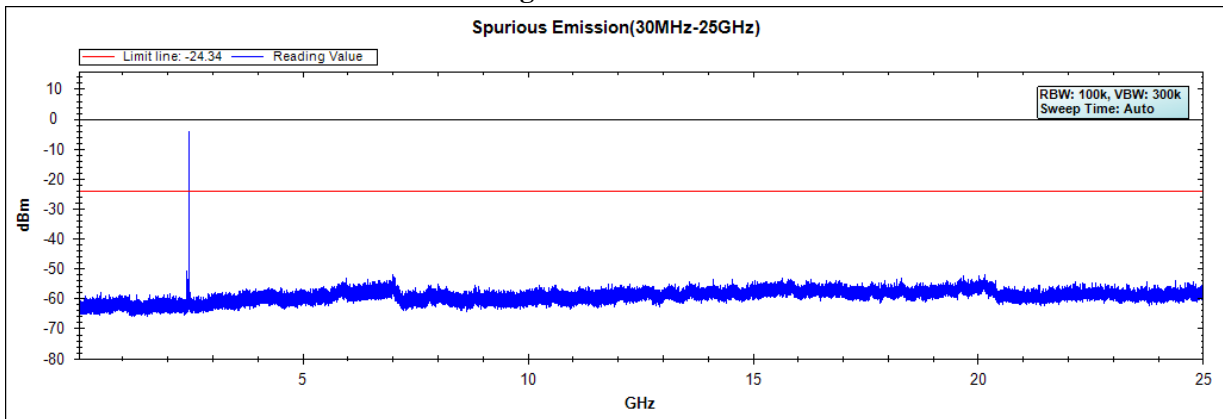

Figure Channel 02:



Note: The above test pattern is synthesized by multiple of the frequency range.

Product : Wireless Receiver
 Test Item : RF Antenna Conducted Test
 Test Mode : Mode 2: Transmit (Antenna: 1)
 Test Date : 2017/03/16

Figure Channel 01:

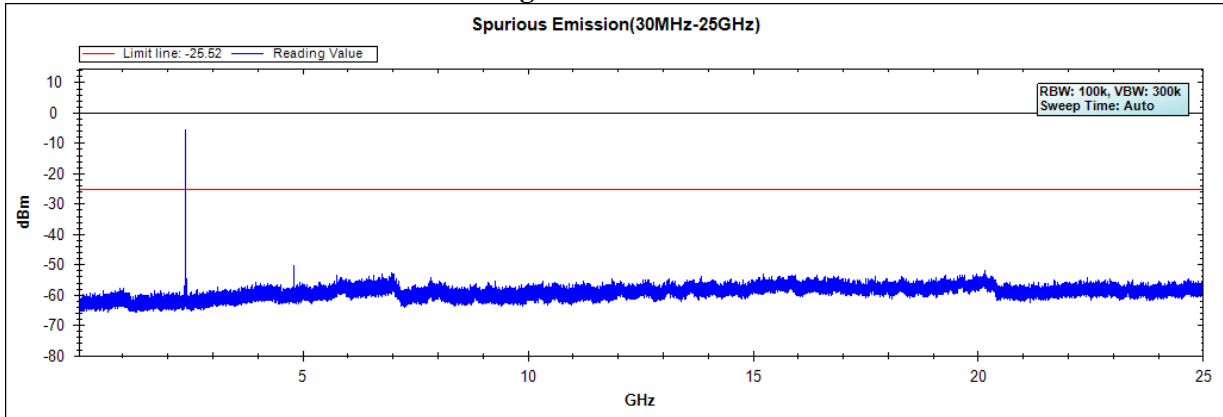
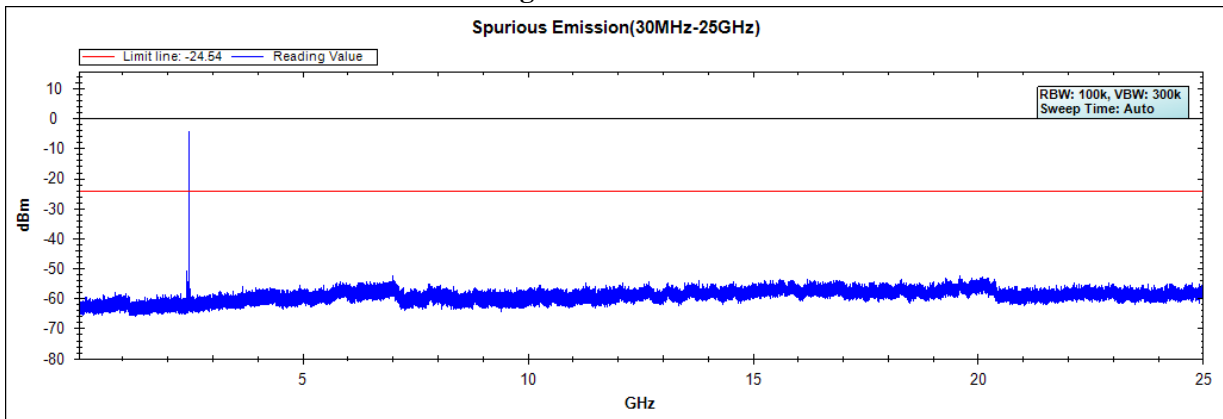

Figure Channel 02:



Note: The above test pattern is synthesized by multiple of the frequency range.

6. Band Edge

6.1. Test Setup

RF Conducted Measurement

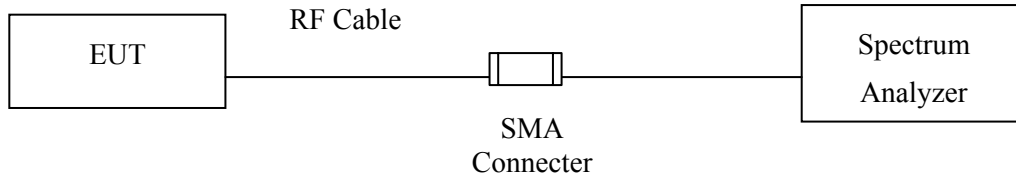

RF Radiated Measurement:

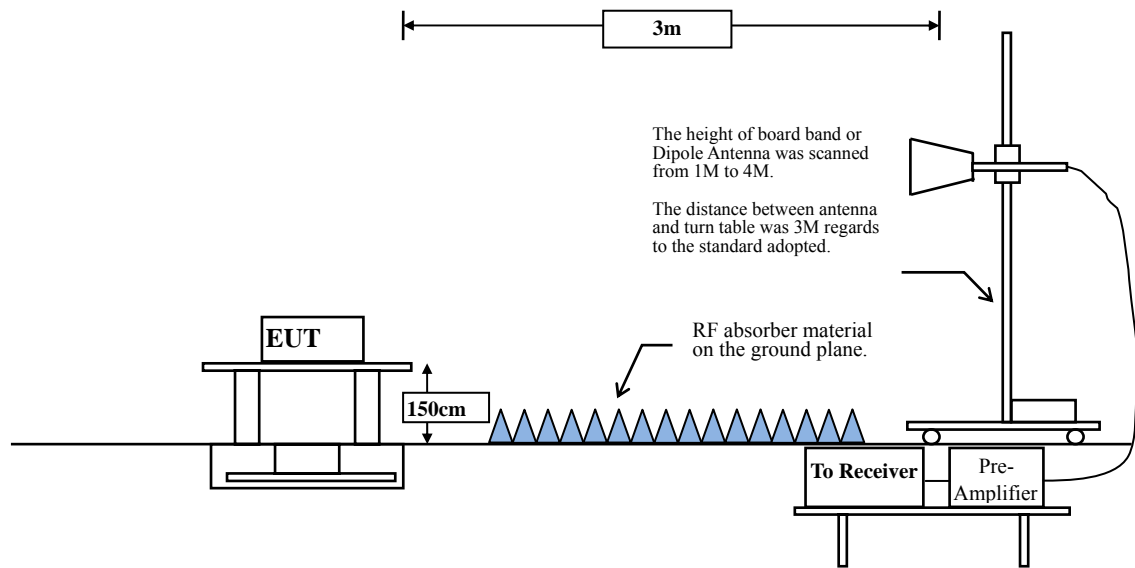

6.2. Limit

According to FCC Section 15.247(d). In any 100 kHz bandwidth outside the frequency band in which the spread spectrum or digitally modulated intentional radiator is operating, the radio frequency power that is produced by the intentional radiator shall be at least 20 dB below that in the 100 kHz bandwidth within the band that contains the highest level of the desired power, based on either an RF conducted or measurement, provided the transmitter demonstrates compliance with the peak conducted power limits. If the transmitter complies with the conducted power limits based on the use of RMS averaging over a time interval, the attenuation required under this paragraph shall be 30 dB instead of 20 dB. Attenuation below the general limits specified in Section 15.209(a) is not required. In addition, radiated emissions which fall in the restricted bands, as defined in Section 15.205(a), must also comply with the radiated emission limits specified in Section 15.209(a) (see Section 15.205(c)).

6.3. Test Procedure

The EUT was setup according to ANSI C63.10, 2013 and tested according to DTS test procedure of KDB558074 for compliance to FCC 47CFR 15.247 requirements.

The EUT is placed on a turn table which is 1.5 meter above ground. The turn table is rotated 360 degrees to determine the position of the maximum emission level. The EUT was positioned such that the distance from antenna to the EUT was 3 meters.

The antenna is scanned from 1 meter to 4 meters to find out the maximum emission level. This is repeated for both horizontal and vertical polarization of the antenna. In order to find the maximum emission, all of the interface cables were manipulated according to ANSI C63.10:2013 on radiated measurement.

6.4. Uncertainty

Conducted: ± 1.23 dB

Radiated:

Horizontal polarization : 1-18GHz: ± 3.77 dB

Vertical polarization : 1-18GHz : ± 3.83 dB

6.5. Test Result of Band Edge

Product : Wireless Receiver
 Test Item : Band Edge Data
 Test Date : 2017/03/14
 Test Mode : Mode 1: Transmit (Antenna: 0) (2402MHz)

RF Radiated Measurement (Horizontal):

Channel No.	Frequency (MHz)	Correct Factor (dB)	Reading Level (dBμV)	Emission Level (dBμV /m)	Peak Limit (dBμV /m)	Average Limit (dBμV /m)	Result
1 (Peak)	2387.246	-8.961	50.718	41.757	74.00	54.00	Pass
1 (Peak)	2390.000	-8.951	49.625	40.675	74.00	54.00	Pass
1 (Peak)	2400.000	-8.912	59.583	50.671	--	--	Pass
1 (Peak)	2402.029	-8.904	101.652	92.748	--	--	Pass
1 (Average)	2390.000	-8.951	37.219	28.269	74.00	54.00	Pass
1 (Average)	2400.000	-8.912	56.418	47.506	--	--	Pass
1 (Average)	2402.029	-8.904	101.553	92.649	--	--	--

Figure Channel 2: Horizontal (Peak)

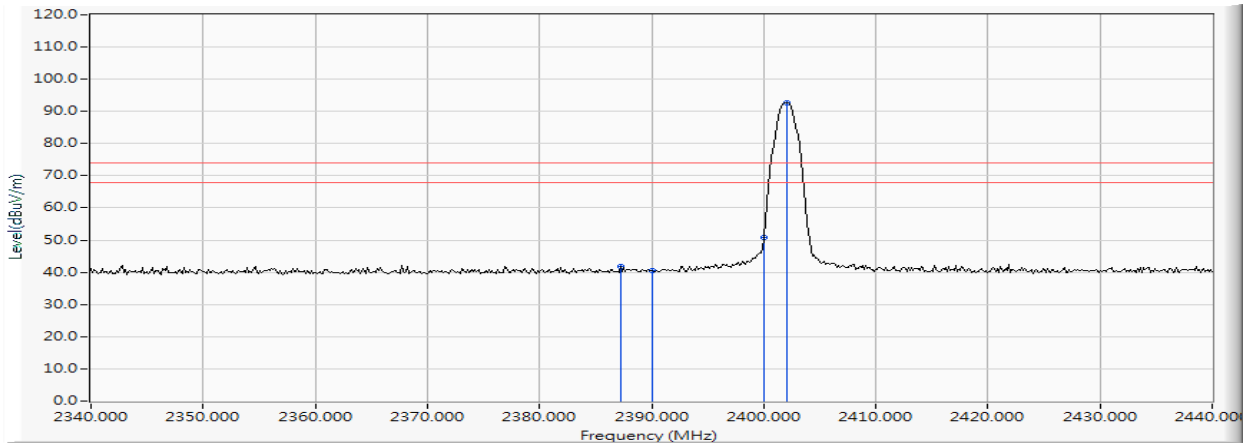
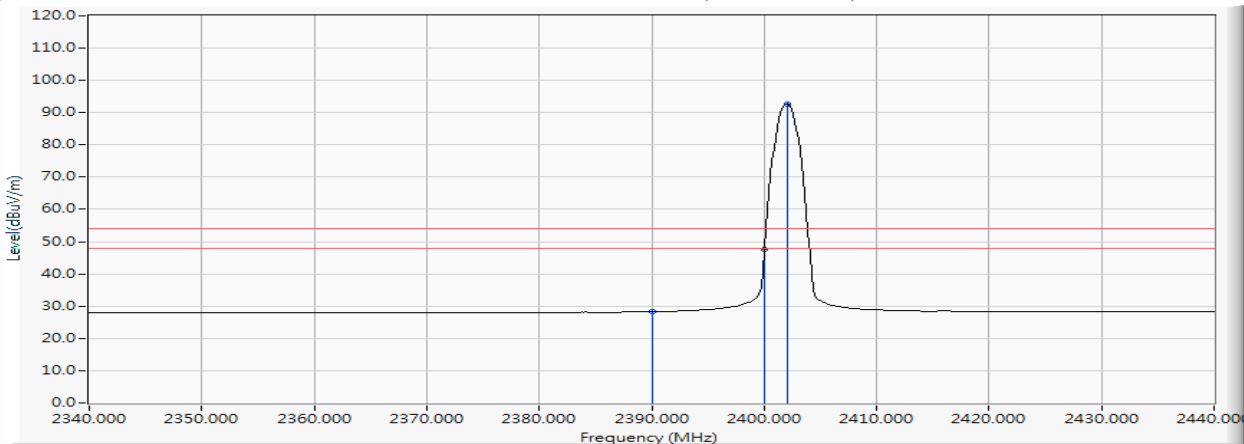

Figure Channel 2: Horizontal (AVERAGE)



Note:

1. All readings above 1GHz are performed with peak and/or average measurements as necessary.
2. Peak measurements: RBW = 1MHz, VBW = 3 MHz, Sweep: Auto.
3. Average measurements: RBW = 1MHz, VBW = 10 Hz, Sweep: Auto.
4. “ * ”, means this data is the worst emission level.
5. Measurement Level = Reading Level + Correct Factor.

Product : Wireless Receiver
 Test Item : Band Edge Data
 Test Date : 2017/03/14
 Test Mode : Mode 1: Transmit (Antenna: 0) (2402MHz)

RF Radiated Measurement (Vertical):

Channel No.	Frequency (MHz)	Correct Factor (dB)	Reading Level (dBµV)	Emission Level (dBµV /m)	Peak Limit (dBµV /m)	Average Limit (dBµV /m)	Result
1 (Peak)	2388.116	-8.957	50.010	41.052	74.00	54.00	Pass
1 (Peak)	2390.000	-8.951	49.605	40.655	74.00	54.00	Pass
1 (Peak)	2400.000	-8.912	52.097	43.185	--	--	Pass
1 (Peak)	2402.029	-8.904	92.667	83.763	--	--	--
1 (Average)	2390.000	-8.951	37.021	28.071	74.00	54.00	Pass
1 (Average)	2400.000	-8.912	47.638	38.726	--	--	Pass
1 (Average)	2402.029	-8.904	92.552	83.648	--	--	--

Figure Channel 2: Vertical (Peak)

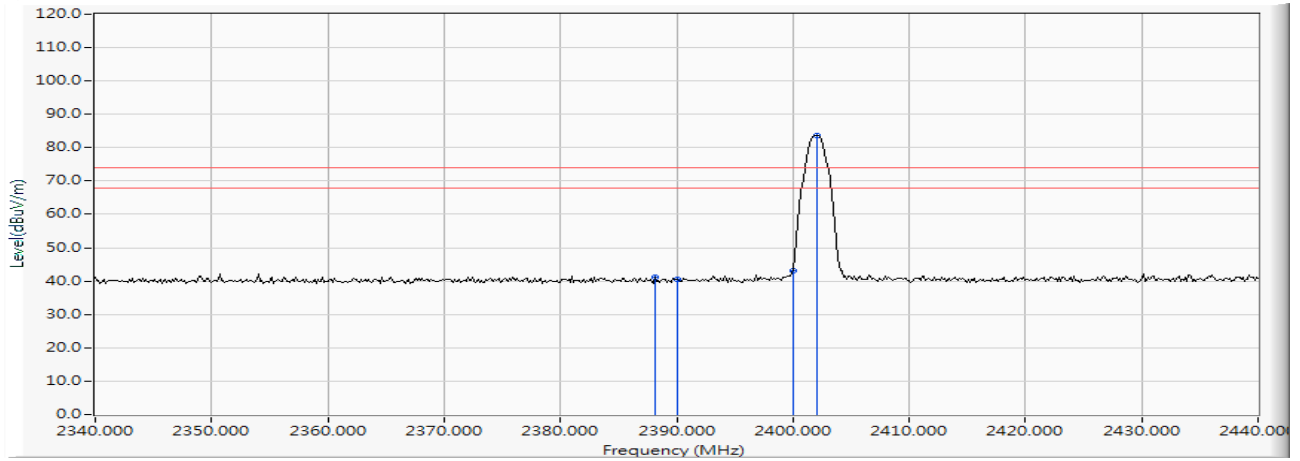
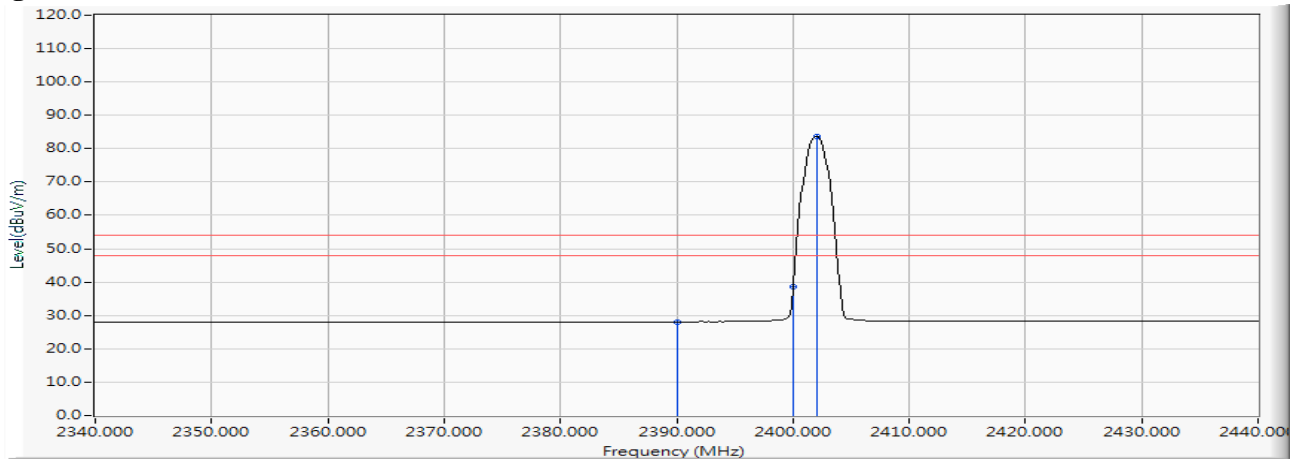

Figure Channel 2: Vertical (AVERAGE)



Note:

1. All readings above 1GHz are performed with peak and/or average measurements as necessary.
2. Peak measurements: RBW = 1MHz, VBW = 3 MHz, Sweep: Auto.
3. Average measurements: RBW = 1MHz, VBW = 10 Hz, Sweep: Auto.
4. “ * ”, means this data is the worst emission level.
5. Measurement Level = Reading Level + Correct Factor.

Product : Wireless Receiver
 Test Item : Band Edge Data
 Test Date : 2017/03/07
 Test Mode : Mode 1: Transmit (Antenna: 0) (2478MHz)

RF Radiated Measurement (Horizontal):

Channel No.	Frequency (MHz)	Correct Factor (dB)	Reading Level (dBμV)	Emission Level (dBμV /m)	Peak Limit (dBμV /m)	Average Limit (dBμV /m)	Result
2 (Peak)	2477.993	-8.622	102.038	93.416	--	--	--
2 (Peak)	2483.500	-8.604	48.112	39.509	--	--	--
2 (Peak)	2484.080	-8.601	49.017	40.416	74.00	54.00	Pass
2 (Average)	2477.993	-8.622	101.956	93.334	--	--	--
2 (Average)	2483.500	-8.604	36.633	28.030	74.00	54.00	Pass

Figure Channel 38: Horizontal (Peak)

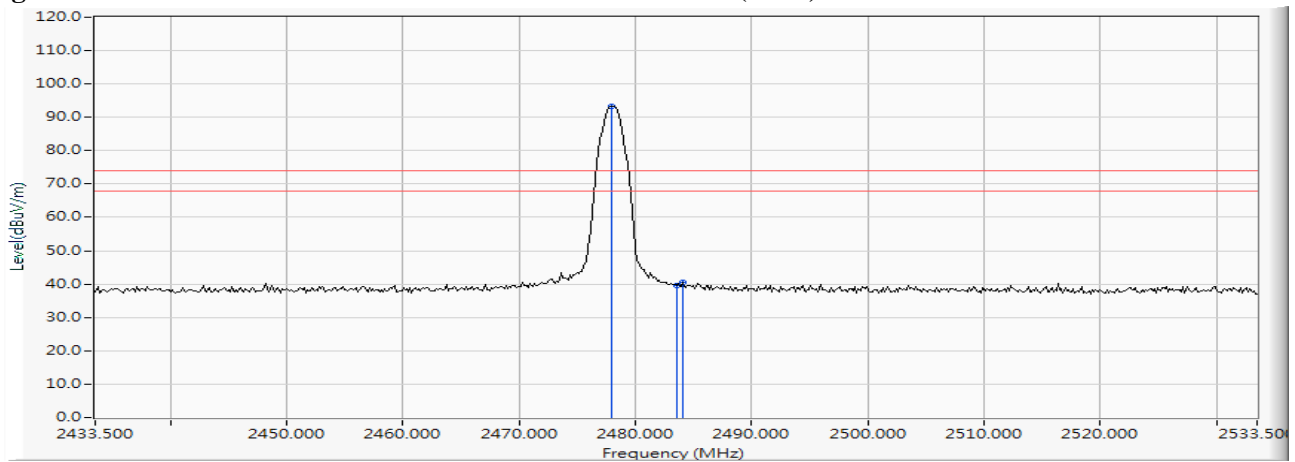
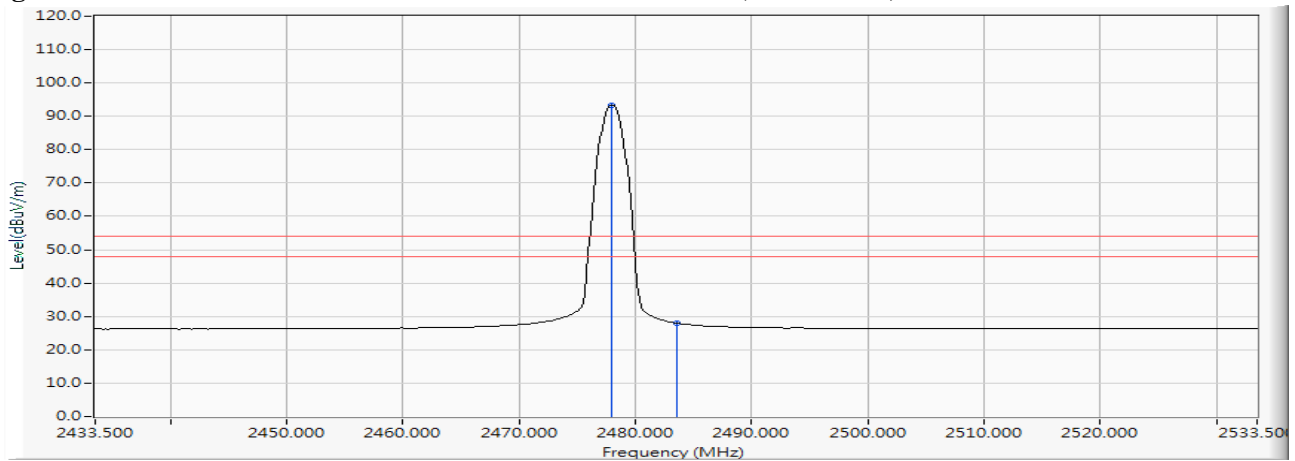

Figure Channel 38: Horizontal (AVERAGE)



Note:

1. All readings above 1GHz are performed with peak and/or average measurements as necessary.
2. Peak measurements: RBW = 1MHz, VBW = 3 MHz, Sweep: Auto.
3. Average measurements: RBW = 1MHz, VBW = 10 Hz, Sweep: Auto.
4. “ * ”, means this data is the worst emission level.
5. Measurement Level = Reading Level + Correct Factor.

Product : Wireless Receiver
 Test Item : Band Edge Data
 Test Date : 2017/03/07
 Test Mode : Mode 1: Transmit (Antenna: 0) (2478MHz)

RF Radiated Measurement (Vertical):

Channel No.	Frequency (MHz)	Correct Factor (dB)	Reading Level (dBμV)	Emission Level (dBμV /m)	Peak Limit (dBμV /m)	Average Limit (dBμV /m)	Result
2 (Peak)	2477.993	-8.622	100.225	91.603	--	--	--
2 (Peak)	2483.500	-8.604	48.202	39.599	74.00	54.00	Pass
2 (Peak)	2484.080	-8.601	48.418	39.817	74.00	54.00	Pass
2 (Average)	2477.993	-8.622	100.132	91.510	--	--	--
2 (Average)	2483.500	-8.604	36.350	27.747	74.00	54.00	Pass

Figure Channel 38: Vertical (Peak)

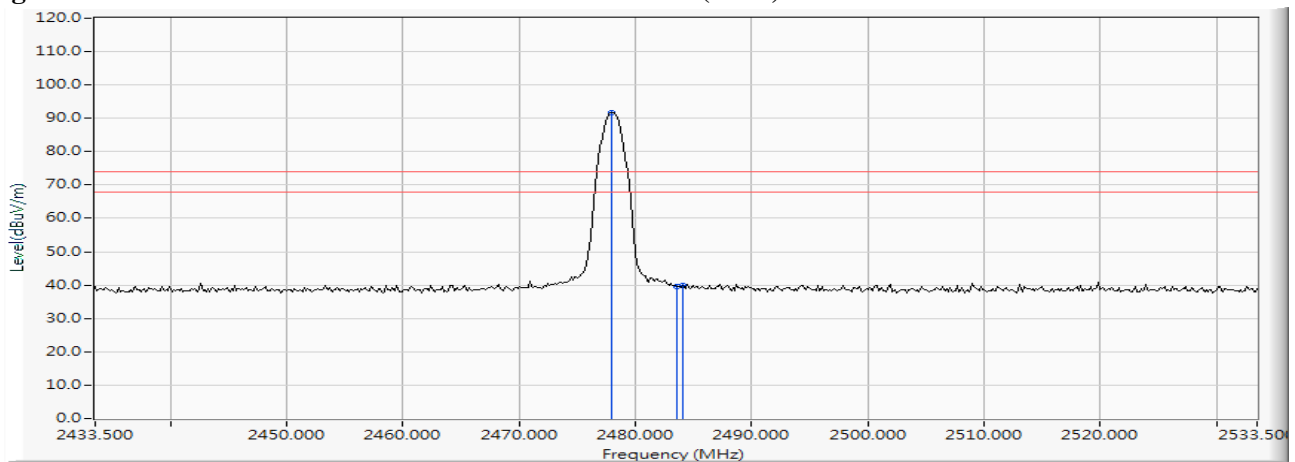
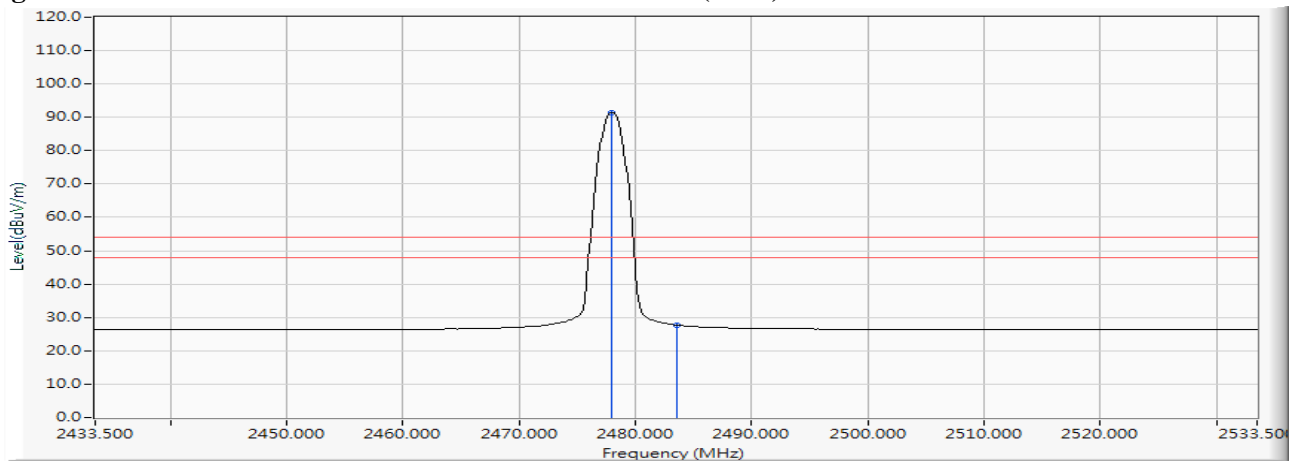

Figure Channel 38: Vertical (Peak)



Note:

1. All readings above 1GHz are performed with peak and/or average measurements as necessary.
2. Peak measurements: RBW = 1MHz, VBW = 3 MHz, Sweep: Auto.
3. Average measurements: RBW = 1MHz, VBW = 10 Hz, Sweep: Auto.
4. “ * ”, means this data is the worst emission level.
5. Measurement Level = Reading Level + Correct Factor.

Product : Wireless Receiver
 Test Item : Band Edge Data
 Test Date : 2017/03/14
 Test Mode : Mode 2: Transmit (Antenna: 1) (2402MHz)

RF Radiated Measurement (Horizontal):

Channel No.	Frequency (MHz)	Correct Factor (dB)	Reading Level (dBμV)	Emission Level (dBμV/m)	Peak Limit (dBμV/m)	Average Limit (dBμV/m)	Result
1 (Peak)	2387.971	-8.958	51.518	42.560	74.00	54.00	Pass
1 (Peak)	2390.000	-8.951	49.174	40.224	74.00	54.00	Pass
1 (Peak)	2400.000	-8.912	59.530	50.618	--	--	Pass
1 (Peak)	2402.029	-8.904	101.917	93.013	--	--	--
1 (Average)	2390.000	-8.951	37.184	28.234	74.00	54.00	Pass
1 (Average)	2400.000	-8.912	56.710	47.798	--	--	Pass
1 (Average)	2402.029	-8.904	101.832	92.928	--	--	--

Figure Channel 2: Horizontal (Peak)

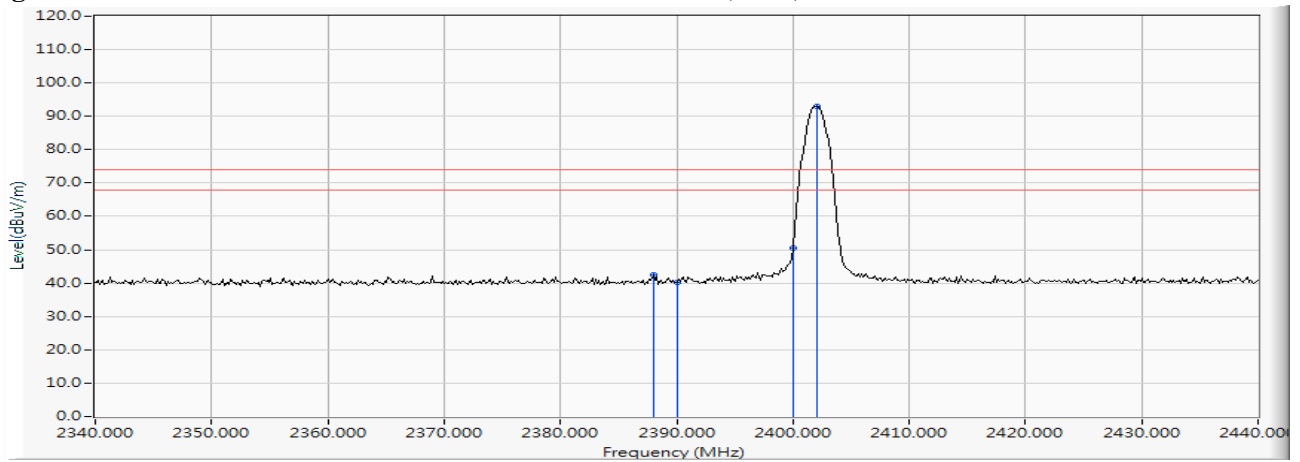
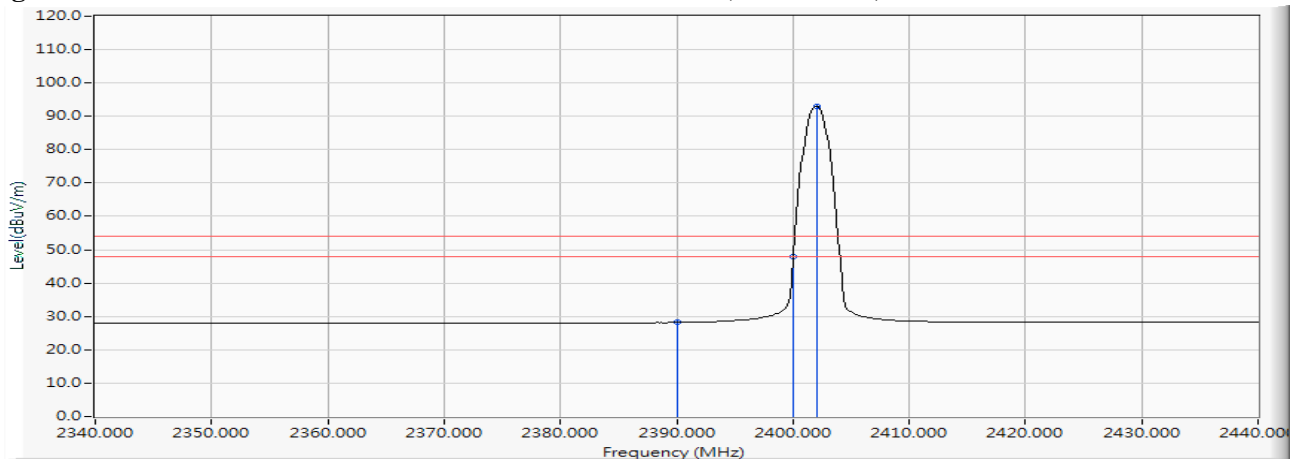

Figure Channel 2: Horizontal (AVERAGE)



Note:

1. All readings above 1GHz are performed with peak and/or average measurements as necessary.
2. Peak measurements: RBW = 1MHz, VBW = 3 MHz, Sweep: Auto.
3. Average measurements: RBW = 1MHz, VBW = 10 Hz, Sweep: Auto.
4. “ * ”, means this data is the worst emission level.
5. Measurement Level = Reading Level + Correct Factor.

Product : Wireless Receiver
 Test Item : Band Edge Data
 Test Date : 2017/03/14
 Test Mode : Mode 2: Transmit (Antenna: 1) (2402MHz)

RF Radiated Measurement (Vertical):

Channel No.	Frequency (MHz)	Correct Factor (dB)	Reading Level (dBµV)	Emission Level (dBµV /m)	Peak Limit (dBµV /m)	Average Limit (dBµV /m)	Result
1 (Peak)	2385.217	-8.968	49.796	40.827	74.00	54.00	Pass
1 (Peak)	2390.000	-8.951	48.753	39.803	74.00	54.00	Pass
1 (Peak)	2400.000	-8.912	52.675	43.763	--	--	Pass
1 (Peak)	2402.029	-8.904	93.965	85.061	--	--	--
1 (Average)	2390.000	-8.951	37.049	28.099	74.00	54.00	Pass
1 (Average)	2400.000	-8.912	48.840	39.928	--	--	Pass
1 (Average)	2402.029	-8.904	93.841	84.937	--	--	--

Figure Channel 2: Vertical (Peak)

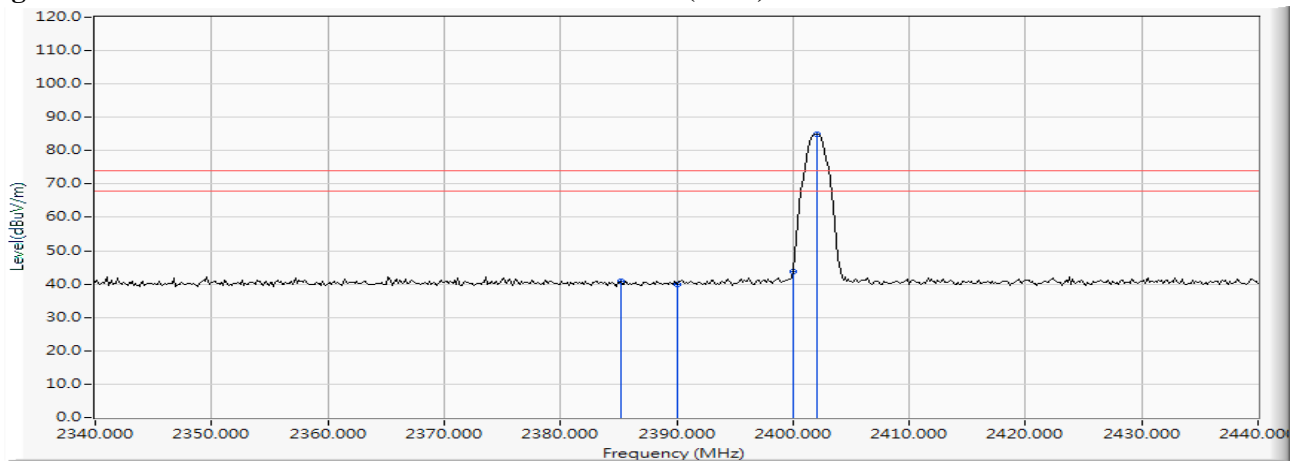
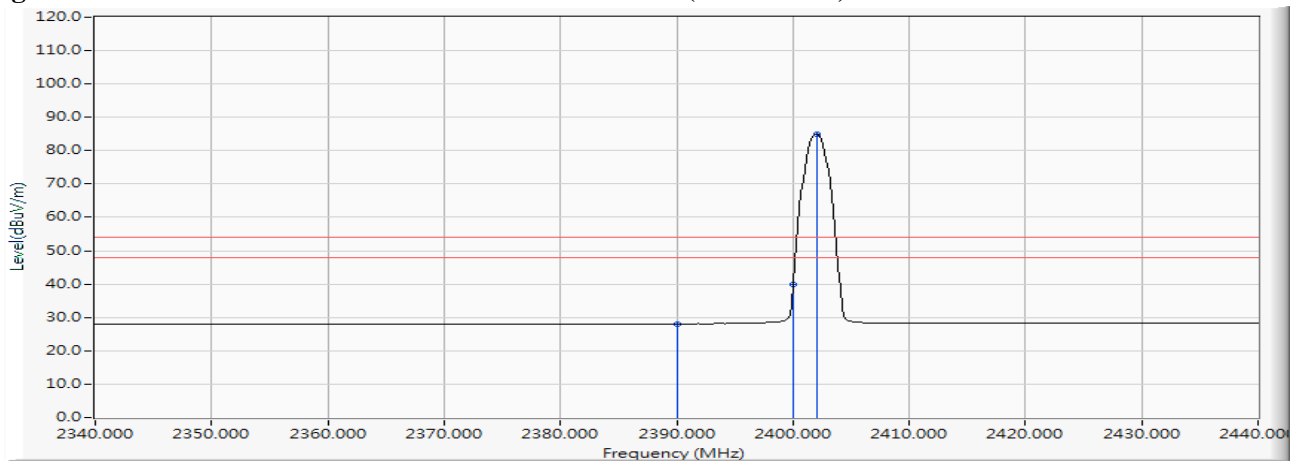

Figure Channel 2: Vertical (AVERAGE)



Note:

1. All readings above 1GHz are performed with peak and/or average measurements as necessary.
2. Peak measurements: RBW = 1MHz, VBW = 3 MHz, Sweep: Auto.
3. Average measurements: RBW = 1MHz, VBW = 10 Hz, Sweep: Auto.
4. “ * ”, means this data is the worst emission level.
5. Measurement Level = Reading Level + Correct Factor.

Product : Wireless Receiver
 Test Item : Band Edge Data
 Test Date : 2017/03/07
 Test Mode : Mode 2: Transmit (Antenna: 1) (2478MHz)

RF Radiated Measurement (Horizontal):

Channel No.	Frequency (MHz)	Correct Factor (dB)	Reading Level (dBμV)	Emission Level (dBμV /m)	Peak Limit (dBμV /m)	Average Limit (dBμV /m)	Result
2 (Peak)	2477.993	-8.622	102.474	93.852	--	--	--
2 (Peak)	2483.500	-8.604	50.113	41.510	74.00	54.00	Pass
2 (Average)	2477.993	-8.622	102.388	93.766	--	--	--
2 (Average)	2483.500	-8.604	37.191	28.588	74.00	54.00	Pass

Figure Channel 38: Horizontal (Peak)

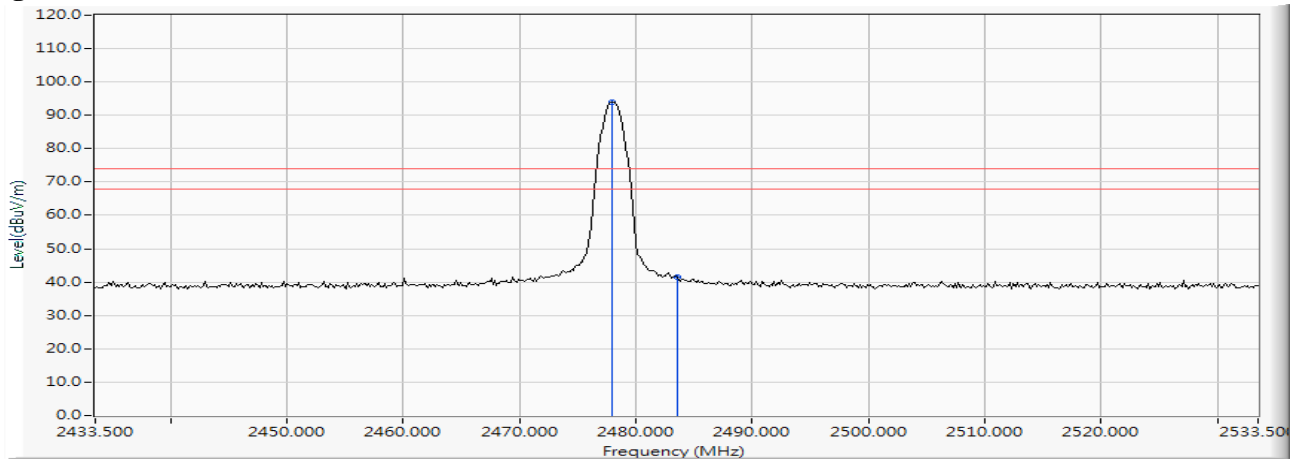
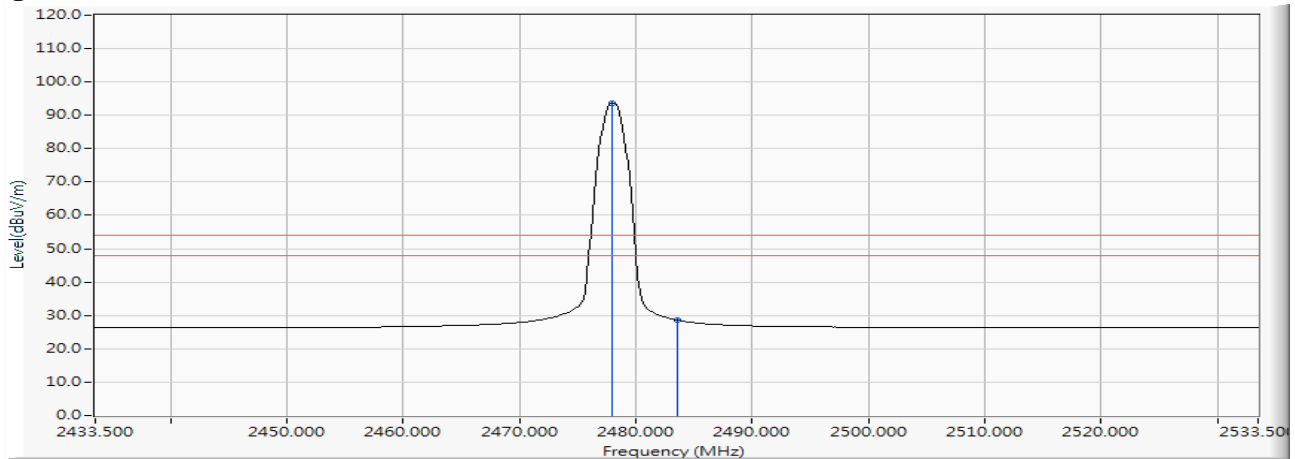

Figure Channel 38: Horizontal (AVERAGE)



Note:

1. All readings above 1GHz are performed with peak and/or average measurements as necessary.
2. Peak measurements: RBW = 1MHz, VBW = 3 MHz, Sweep: Auto.
3. Average measurements: RBW = 1MHz, VBW = 10 Hz, Sweep: Auto.
4. “ * ”, means this data is the worst emission level.
5. Measurement Level = Reading Level + Correct Factor.

Product : Wireless Receiver
 Test Item : Band Edge Data
 Test Date : 2017/03/07
 Test Mode : Mode 2: Transmit (Antenna: 1) (2478MHz)

RF Radiated Measurement (Vertical):

Channel No.	Frequency (MHz)	Correct Factor (dB)	Reading Level (dBμV)	Emission Level (dBμV /m)	Peak Limit (dBμV /m)	Average Limit (dBμV /m)	Result
2 (Peak)	2477.993	-8.622	100.119	91.497	--	--	--
2 (Peak)	2483.500	-8.604	48.052	39.449	74.00	54.00	Pass
2 (Peak)	2484.370	-8.600	48.706	40.106	74.00	54.00	Pass
2 (Average)	2477.993	-8.622	100.029	91.407	--	--	--
2 (Average)	2483.500	-8.604	36.436	27.833	74.00	54.00	Pass

Figure Channel 38: Vertical (Peak)

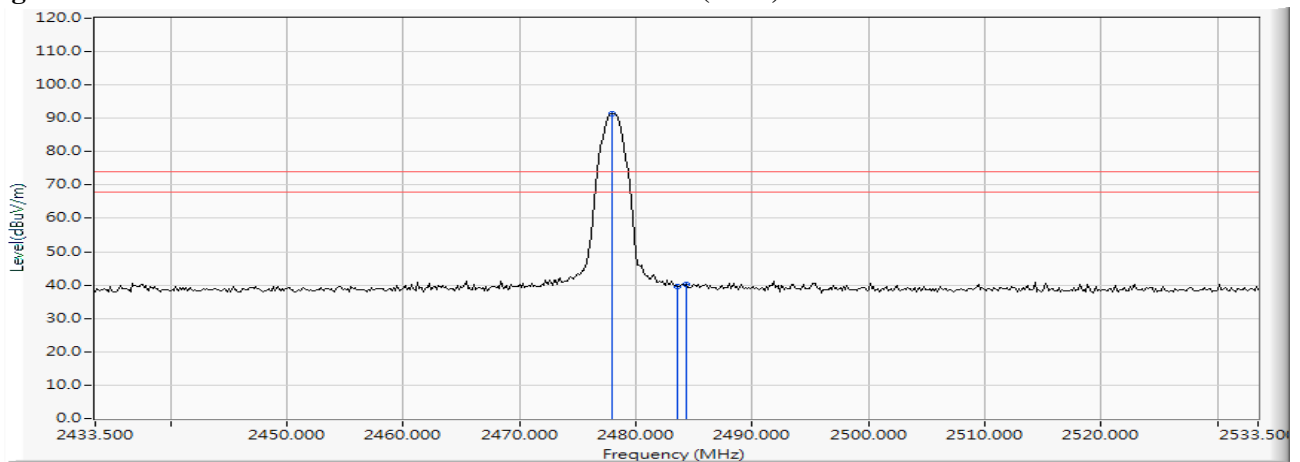
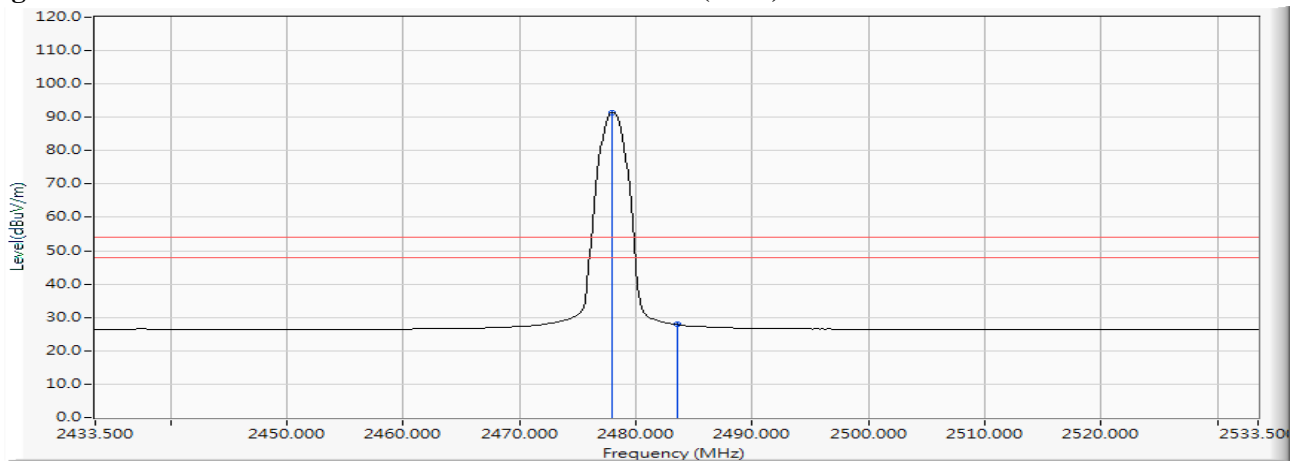

Figure Channel 38: Vertical (Peak)



Note:

1. All readings above 1GHz are performed with peak and/or average measurements as necessary.
2. Peak measurements: RBW = 1MHz, VBW = 3 MHz, Sweep: Auto.
3. Average measurements: RBW = 1MHz, VBW = 10 Hz, Sweep: Auto.
4. “ * ”, means this data is the worst emission level.
5. Measurement Level = Reading Level + Correct Factor.

7. 6dB Bandwidth

7.1. Test Setup

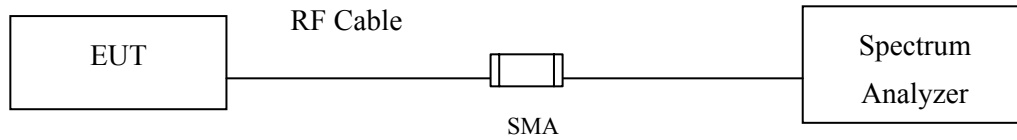

7.2. Limits

The minimum bandwidth shall be at least 500 kHz.

7.3. Test Procedure

The EUT was setup according to ANSI C63.10 2013; tested according to DTS test procedure of KDB558074 for compliance to FCC 47CFR 15.247 requirements.

Set RBW = 1-5% of the emission bandwidth, $VBW \geq 3 * RBW$

7.4. Uncertainty

$\pm 279.2\text{Hz}$

7.5. Test Result of 6dB Bandwidth

Product : Wireless Receiver
 Test Item : 6dB Bandwidth Data
 Test Mode : Mode 1: Transmit (Antenna: 0) (2402MHz)
 Test Date : 2017/03/16

Channel No.	Frequency (MHz)	Measurement Level (kHz)	Required Limit (kHz)	Result
01	2402	740	>500	Pass

Figure Channel 01:

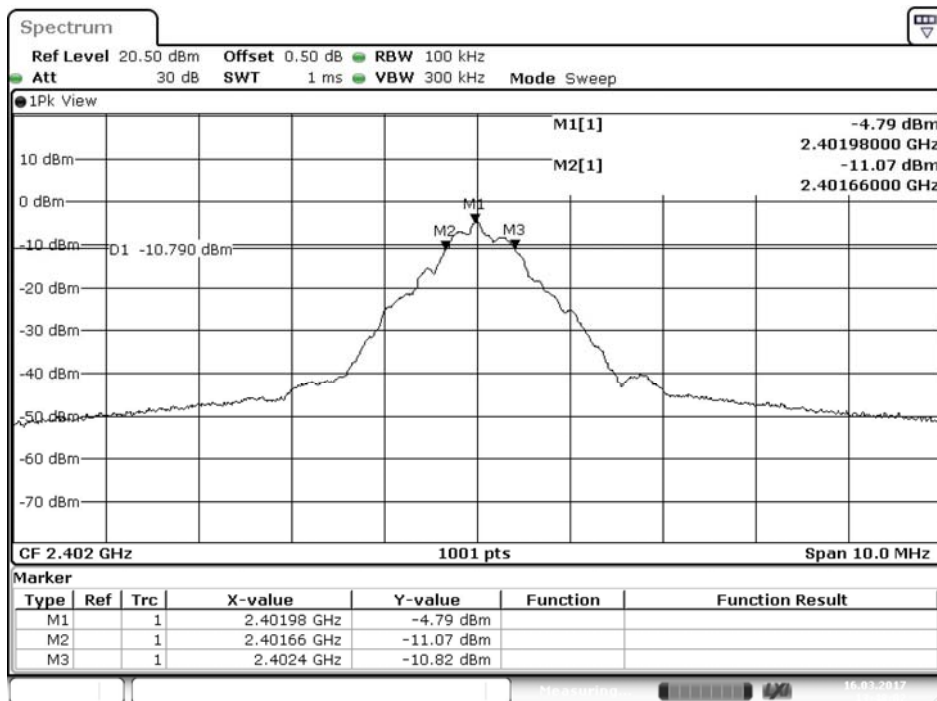

Date: 16.MAR.2017 13:48:03

Product : Wireless Receiver
 Test Item : 6dB Bandwidth Data
 Test Mode : Mode 1: Transmit (Antenna: 0) (2478MHz)
 Test Date : 2017/03/16

Channel No.	Frequency (MHz)	Measurement Level (kHz)	Required Limit (kHz)	Result
02	2478	730	>500	Pass

Figure Channel 02:

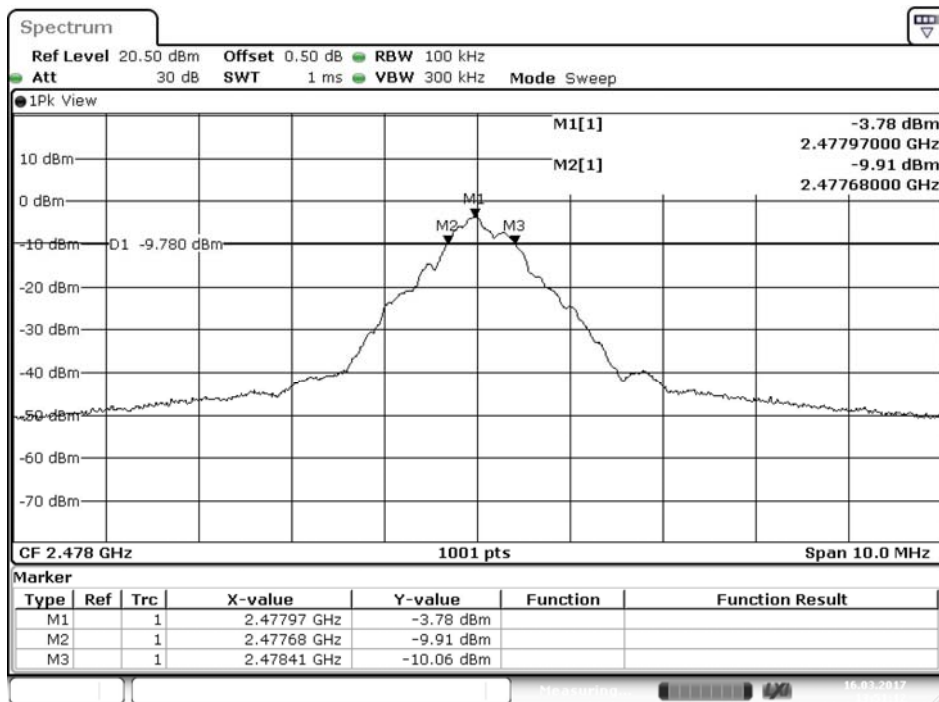

Date: 16.MAR.2017 13:51:12

Product : Wireless Receiver
 Test Item : 6dB Bandwidth Data
 Test Mode : Mode 2: Transmit (Antenna: 1) (2402MHz)
 Test Date : 2017/03/16

Channel No.	Frequency (MHz)	Measurement Level (kHz)	Required Limit (kHz)	Result
01	2402	760	>500	Pass

Figure Channel 01:

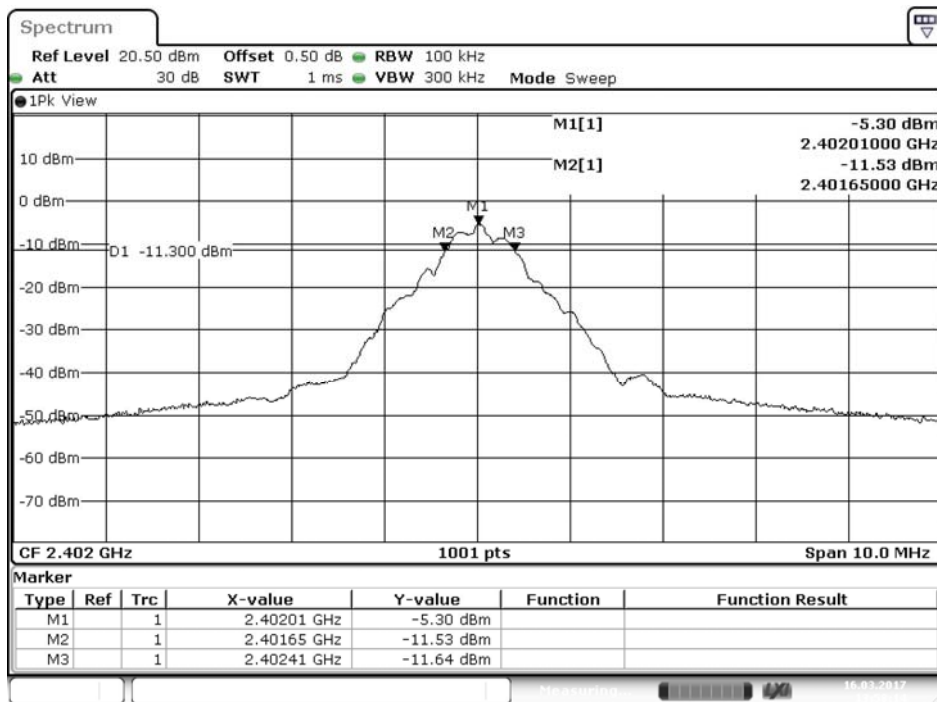

Date: 16.MAR.2017 13:58:15

Product : Wireless Receiver
 Test Item : 6dB Bandwidth Data
 Test Mode : Mode 2: Transmit (Antenna: 1) (2478MHz)
 Test Date : 2017/03/16

Channel No.	Frequency (MHz)	Measurement Level (kHz)	Required Limit (kHz)	Result
02	2478	710	>500	Pass

Figure Channel 02:

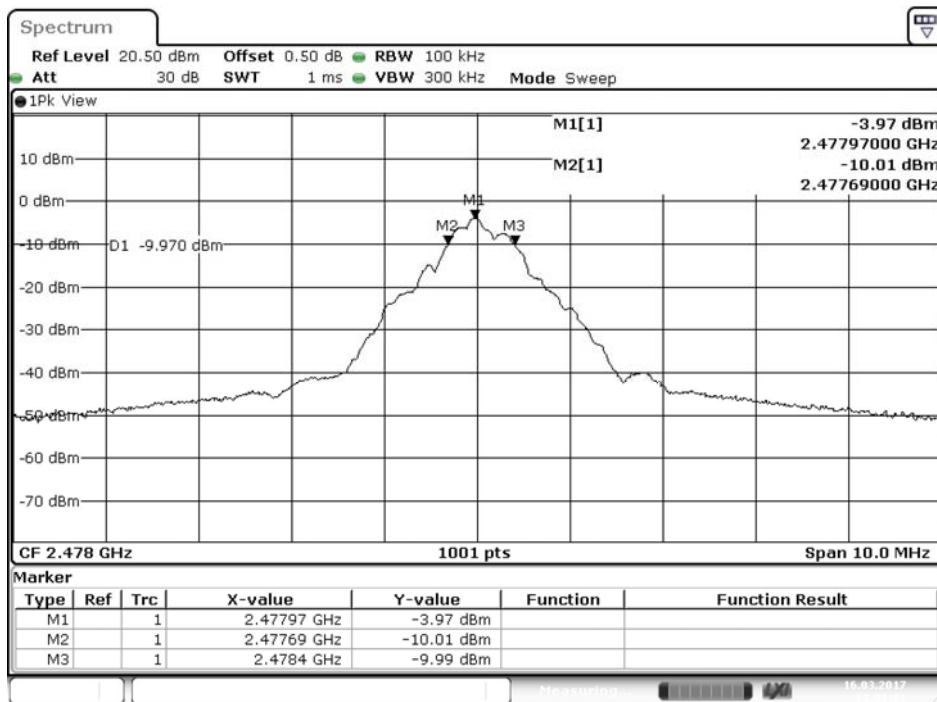

Date: 16.MAR.2017 14:01:02

8. Power Density

8.1. Test Setup

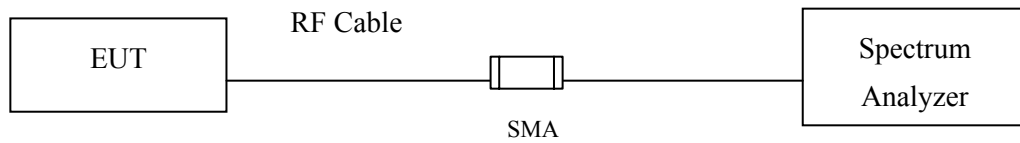

8.2. Limits

The transmitted power density averaged over any 1 second interval shall not be greater +8dBm in any 3kHz bandwidth.

8.3. Test Procedure

The EUT was setup according to ANSI C63.10: 2013, the maximum power spectral density using KDB 558074 section 10.2 PKPSD (peak PSD) method.

8.4. Uncertainty

$\pm 1.23\text{dB}$

8.5. Test Result of Power Density

Product : Wireless Receiver
 Test Item : Power Density Data
 Test Mode : Mode 1: Transmit (Antenna: 0) (2402MHz)
 Test Date : 2017/03/16

Channel No.	Frequency (MHz)	Measure Level (dBm)	Limit (dBm)	Result
01	2402	-5.26	≤ 8dBm	Pass

Figure Channel 01:

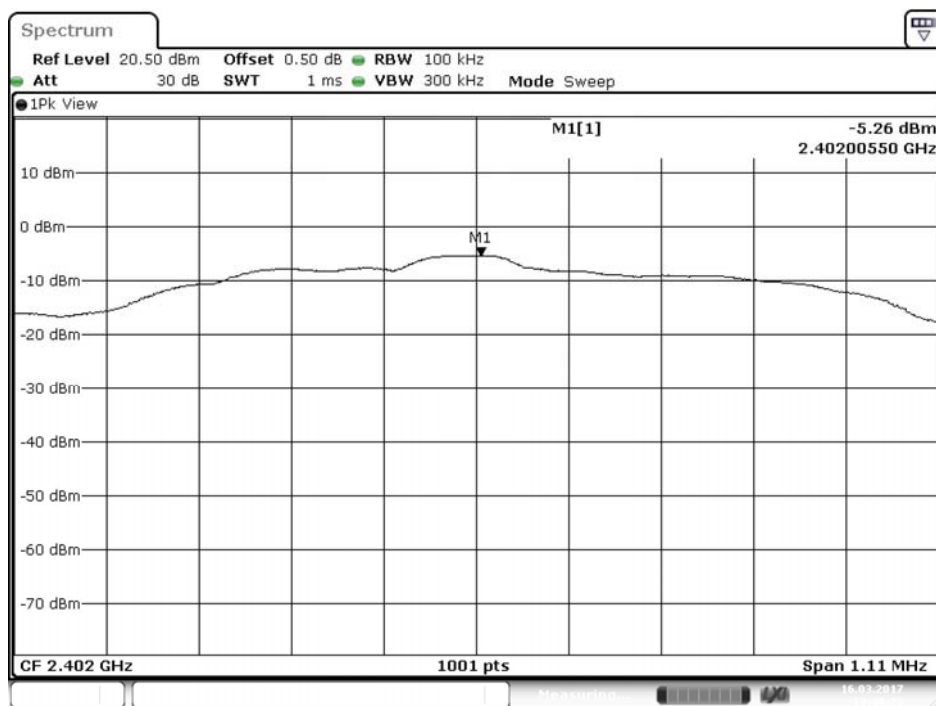

Product : Wireless Receiver
 Test Item : Power Density Data
 Test Mode : Mode 1: Transmit (Antenna: 0) (2478MHz)
 Test Date : 2017/03/16

Channel No.	Frequency (MHz)	Measurement Level (dBm)	Required Limit (dBm)	Result
02	2478	-4.34	≤ 8dBm	Pass

Figure Channel 02:

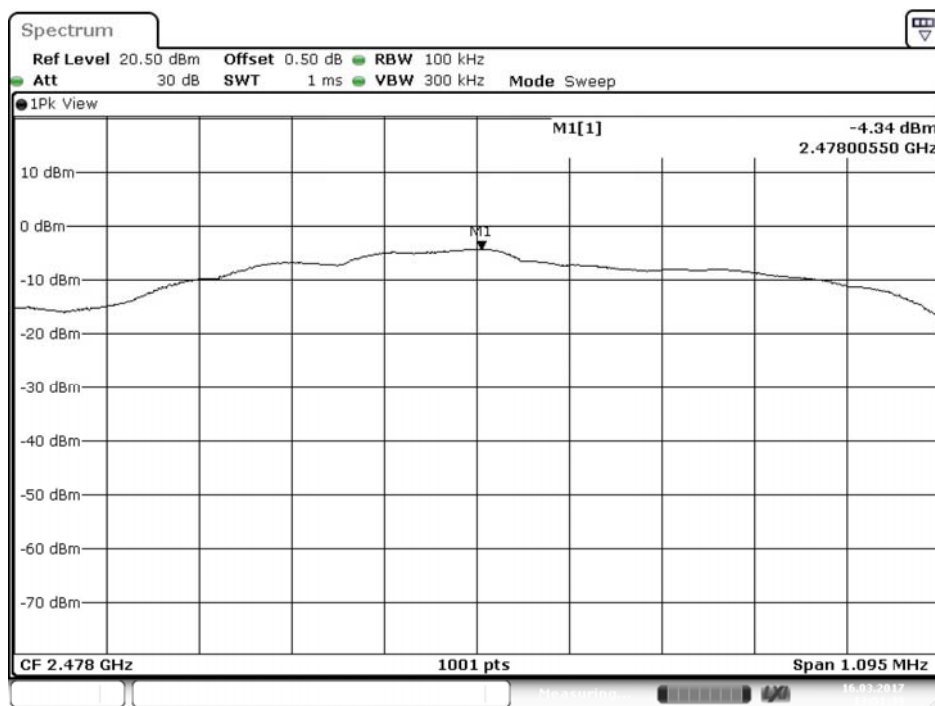

Product : Wireless Receiver
 Test Item : Power Density Data
 Test Mode : Mode 2: Transmit (Antenna: 1) (2402MHz)
 Test Date : 2017/03/16

Channel No.	Frequency (MHz)	Measure Level (dBm)	Limit (dBm)	Result
01	2402	-5.52	≤ 8dBm	Pass

Figure Channel 01:

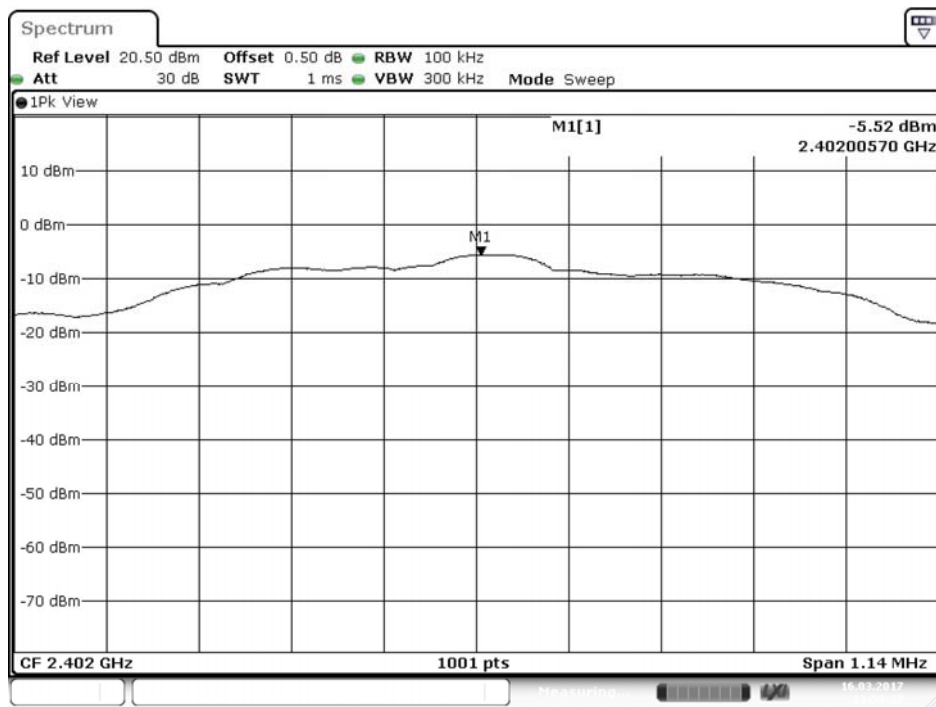

Date: 16.MAR.2017 13:58:37

Product : Wireless Receiver
 Test Item : Power Density Data
 Test Mode : Mode 2: Transmit (Antenna: 1) (2478MHz)
 Test Date : 2017/03/16

Channel No.	Frequency (MHz)	Measurement Level (dBm)	Required Limit (dBm)	Result
02	2478	-4.54	≤ 8dBm	Pass

Figure Channel 02:

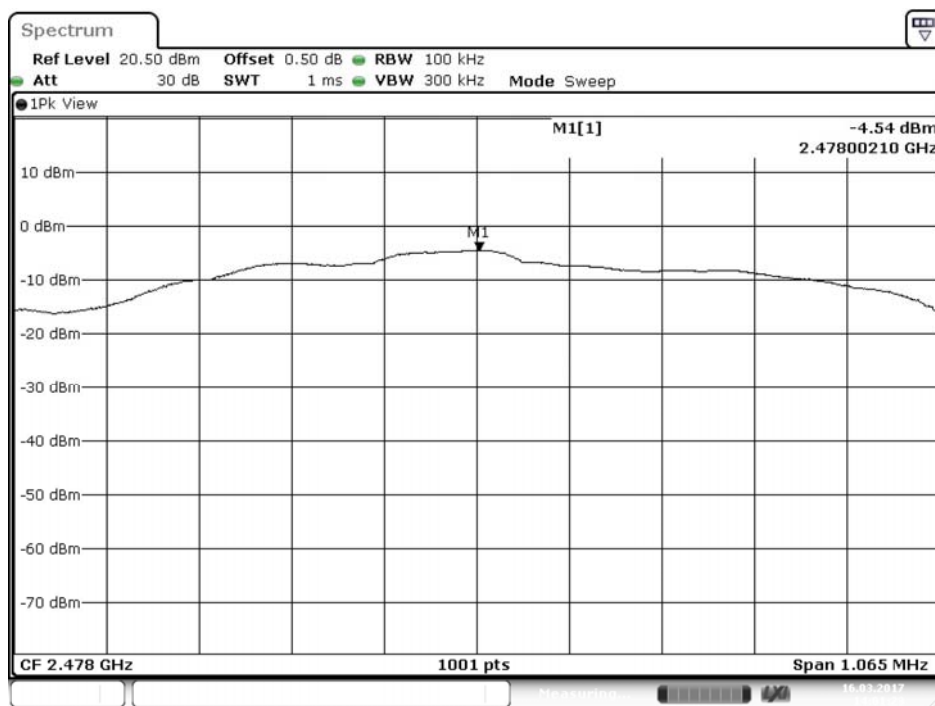

Date: 16.MAR.2017 14:01:23

9. EMI Reduction Method During Compliance Testing

No modification was made during testing.

Attachment 1: EUT Test Photographs

Attachment 2: EUT Detailed Photographs