



243 Jubug-Ri, Yangji-Myeon, Yongin-Si, Gyeonggi-Do, Korea 17159
Tel: +82-31-323-6008 Fax: +82-31-323-6010
<http://www.ltalab.com>

Dates of Tests: August 20 ~ September 01, 2018
Test Report S/N: LR50011809A
Test Site : LTA CO., LTD.

CERTIFICATION OF COMPLIANCE

FCC ID.

2AJ6BBHTTT0100

APPLICANT

bHaptics, Inc.

Equipment Class	:	Digital Transmission System (DTS)
Manufacturing Description	:	TACTOT
Manufacturer	:	bHaptics, Inc.
Model name	:	BHTTT0100
Test Device Serial No.:	:	Identical prototype
Rule Part(s)	:	FCC Part 15.247 Subpart C ; ANSI C-63.4-2014
Frequency Range	:	2402 ~ 2480 MHz
Max. Output Power	:	Max -1.85 dBm – Conducted
Data of issue	:	September 01, 2018

This test report is issued under the authority of:

The test was supervised by:

Ja-Beom, Koo / Director

Hee-Cheon, Kwon, Test Engineer

This test result only responds to the tested sample. It is not allowed to copy this report even partly without the allowance of the test laboratory. The report must not be used by the client to claim product certification, approval, or endorsement by NVLAP, NIST, or any agency of the Federal Government.



NVLAP LAB Code.: 200723-0

TABLE OF CONTENTS

1. GENERAL INFORMATION	-----	3
2. INFORMATION ABOUT TEST ITEM	-----	4
3. TEST REPORT	-----	5
3.1 SUMMARY OF TESTS	-----	5
3.2 TECHNICAL CHARACTERISTICS TEST	-----	6
3.2.1 6 dB BANDWIDTH	-----	6
3.2.2 PEAK OUTPUT POWER	-----	9
3.2.3 POWER SPECTRAL DENSITY	-----	12
3.2.4 BAND EDGE	-----	15
3.2.5 CONDUCTED SPURIOUS EMISSIONS	-----	18
3.2.6 RADIATED SPURIOUS EMISSIONS	-----	21
3.2.7 AC Conducted Emissions	-----	33
APPENDIX		
APPENDIX TEST EQUIPMENT USED FOR TESTS	-----	36

1. General information

1-1 Test Performed

Company name : LTA Co., Ltd.
 Address : 243, Jubug-ri, Yangji-Myeon, Youngin-Si, Kyunggi-Do, Korea. 17159
 Web site : <http://www.ltalab.com>
 E-mail : chahn@ltalab.com
 Telephone : +82-31-323-6008
 Facsimile : +82-31-323-6010

Quality control in the testing laboratory is implemented as per ISO/IEC 17025 which is the “General requirements for the competents of calibration and testing laboratory”.

1-2 Accredited agencies

LTA Co., Ltd. is approved to perform EMC testing by the following agencies:

Agency	Country	Accreditation No.	Validity	Reference
NVLAP	U.S.A	200723-0	2018-09-30	ECT accredited Lab.
RRA	KOREA	KR0049	-	EMC accredited Lab.
FCC	U.S.A	649054	2019-04-13	FCC CAB
VCCI	JAPAN	C-4948,	2020-09-10	VCCI registration
VCCI	JAPAN	T-2416,	2020-09-10	VCCI registration
VCCI	JAPAN	R-4483(10 m),	2020-10-15	VCCI registration
VCCI	JAPAN	G-847	2018-12-13	VCCI registration
IC	CANADA	5799A-1	2019-11-07	IC filing
KOLAS	KOREA	NO.551	2021-08-20	KOLAS accredited Lab.
NVLAP	U.S.A	200723-0	2019-03-15	ECT accredited Lab.

2. Information about test item

2-1 Client & Manufacturer

Company name : bHaptics, Inc.
 Address : Admin.B/D-A606, KAIST-ICC, 193, Munji-ro, Yuseong-gu, Daejeon
 Tel / Fax : TEL No : +82-42-867-2468 / FAX No : +82-42-867-2467

2-2 Equipment Under Test (EUT)

Model name : BHTTT0100
 Serial number : Identical prototype
 Date of receipt : August 20, 2018
 EUT condition : Pre-production, not damaged
 Antenna type : Chip Antenna (Max Gain : 0.5 dBi)
 Frequency Range : 2402 ~ 2480 MHz
 RF output power : Max -1.85 dBm – Conducted
 Number of channels : 40
 Type of Modulation : GFSK
 Power Source : 3.78 Vdc by Bettery

2-3 Tested frequency

	LOW	MID	HIGH
Frequency (MHz)	2402	2442	2480

2-4 Ancillary Equipment

Equipment	Model No.	Serial No.	Manufacturer
Notebook	CR720	MS-1736	MSI

3. Test Report

3.1 Summary of tests

FCC Part Section(s)	Parameter	Limit	Test Condition	Status (note 1)
15.247(a)	6 dB Bandwidth	> 500 kHz	Conducted	C
15.247(b)	Transmitter Peak Output Power	< 1 Watt		C
15.247(d)	Transmitter Power Spectral Density	< 8 dBm @ 3 kHz		C
15.247(d)	Band Edge	> 20 dBc		C
15.209	Field Strength of Harmonics	Emission	Radiated	C
15.207	AC Conducted Emissions	Emissions	Conducted	N/A
15.203	Antenna requirement	-	-	C

Note 1: C=Complies NC=Not Complies NT=Not Tested NA=Not Applicable

Note 2: The data in this test report are traceable to the national or international standards.

The above equipment was tested by LTA Co., Ltd. The test data, data evaluation, test procedures, and equipment configurations shown in this report were made in accordance with the procedures given in ANSI C63.10-2013 and the energy emitted by the sample EUT tested as described in this report is in compliance with the requirements of FCC Rules Part 2 and Part 15.247 The test results of this report relate only to the tested sample identified in this report.

→ Antenna Requirement

The bHaptics, Inc. FCC ID: 2AJ6BBHTTT0100 unit complies with the requirement of §15.203.

The antenna type is Chip Antenna.

3.2 Technical Characteristics Test

3.2.1 6 dB Bandwidth

Procedure:

The bandwidth at 6 dB below the highest in-band spectral density was measured with a spectrum analyzer connected to the antenna terminal, while EUT is operating in transmission mode at the appropriate frequencies.

After the trace being stable, Use the marker-to-peak function to set the marker to the peak of the emission. Use the marker-delta function to measure 6 dB down one side of the emission. Reset the marker-delta function, and move the marker to the other side of the emission, until it is (as close as possible to) even with the reference marker level. The marker-delta reading at this point is the 6 dB bandwidth of the emission.

The spectrum analyzer is set to:

Center frequency = the highest, middle and the lowest channels

RBW = 100 kHz

Span = 5 MHz

VBW = 100 kHz (VBW \geq RBW)

Sweep = auto

Trace = max hold

Detector function = peak

Measurement Data : **Complies**

Frequency (MHz)	Test Results	
	Measured Bandwidth (MHz)	Result
2402	0.694	Complies
2442	0.701	Complies
2480	0.694	Complies

- See next pages for actual measured spectrum plots.

Minimum Standard:

6 dB Bandwidth > 500 kHz

Measurement Setup

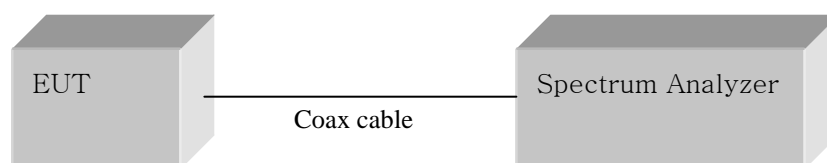
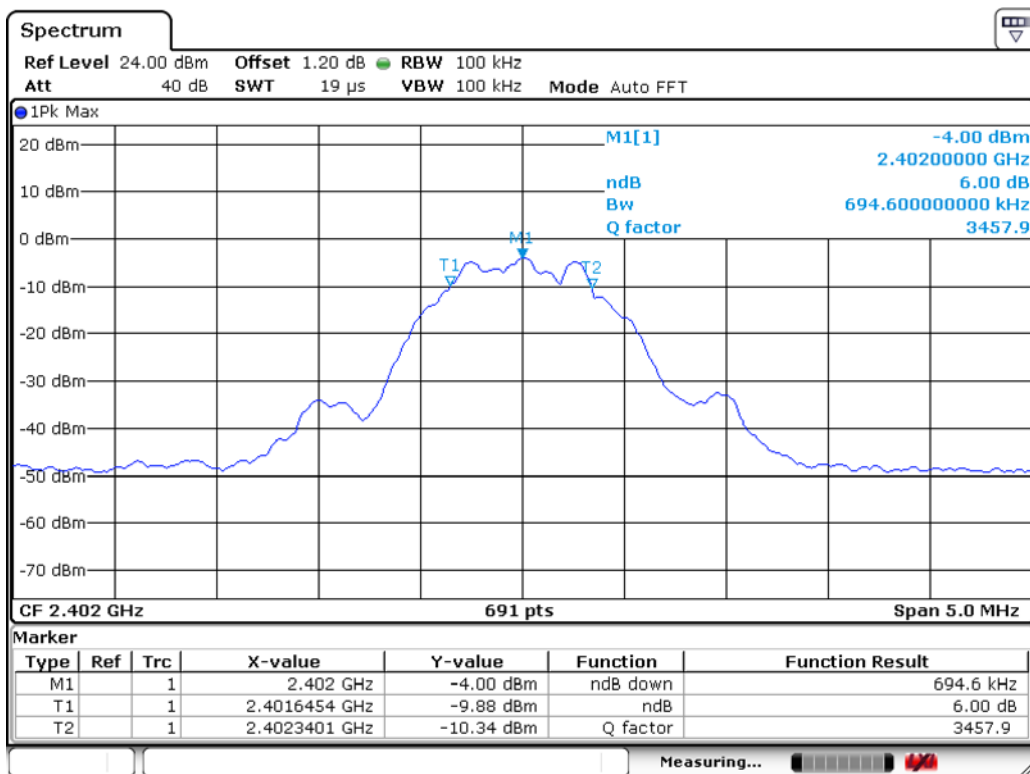
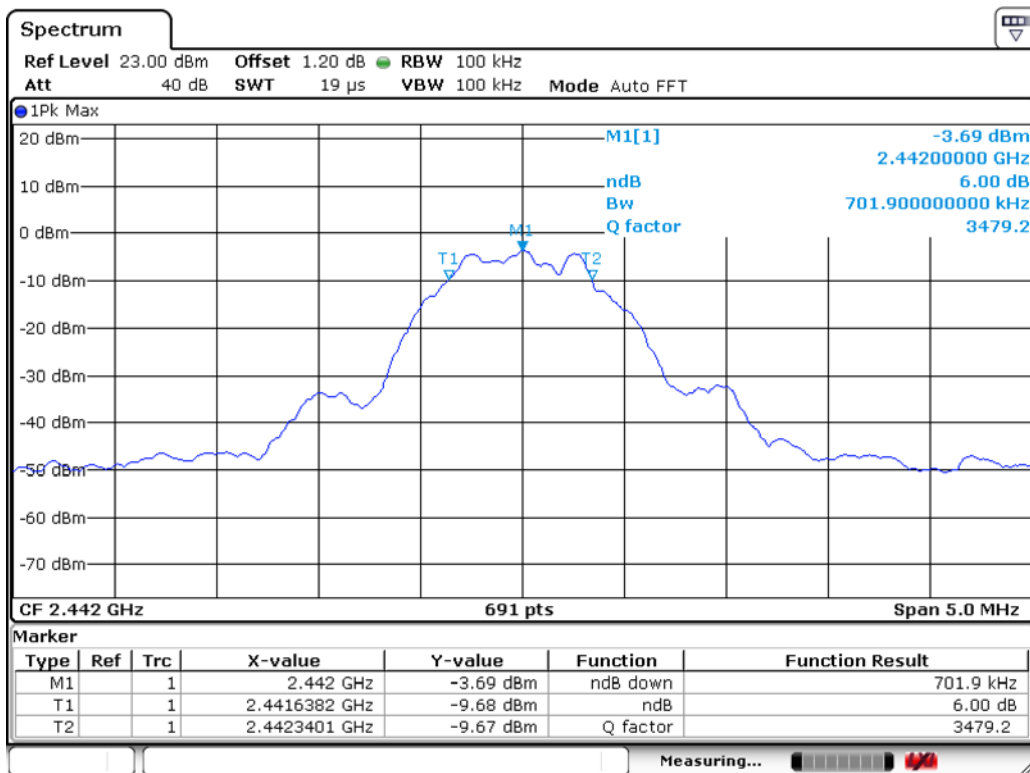

Figure 1: Measurement setup for the carrier frequency separation

Low Channel



Middle Channel



High Channel

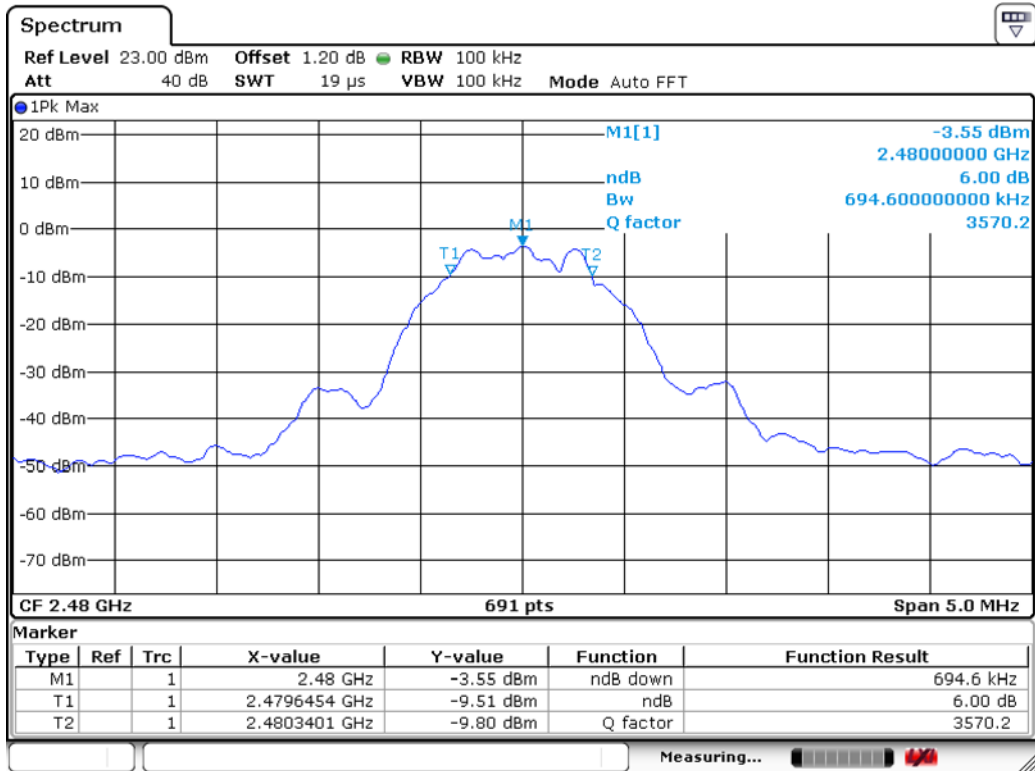

3.2.2 Peak Output Power Measurement

Procedure:

The maximum peak output power was measured with the spectrum analyzer connected to the antenna output of the EUT. The spectrum analyzer's internal channel power integration function is used to integrate the power over a bandwidth greater than or equal to the 99 % bandwidth. The EUT was operating in transmit mode at the appropriate center frequency.

The spectrum analyzer is set to:

Center frequency = the highest, middle and the lowest channels

RBW = 1 MHz

Span = auto

VBW = 1 MHz (VBW \geq RBW)

Sweep = auto

Detector function = peak

Measurement Data : **Complies**

Frequency (MHz)	Test Results		
	dBm	mW	Result
2402	-2.41	0.57	Complies
2442	-1.96	0.64	Complies
2480	-1.85	0.65	Complies

- See next pages for actual measured spectrum plots.

Minimum Standard:

Peak output power	< 1 W
-------------------	-------

Measurement Setup

Same as the Chapter 3.2.1 (Figure 1)

Low Channel

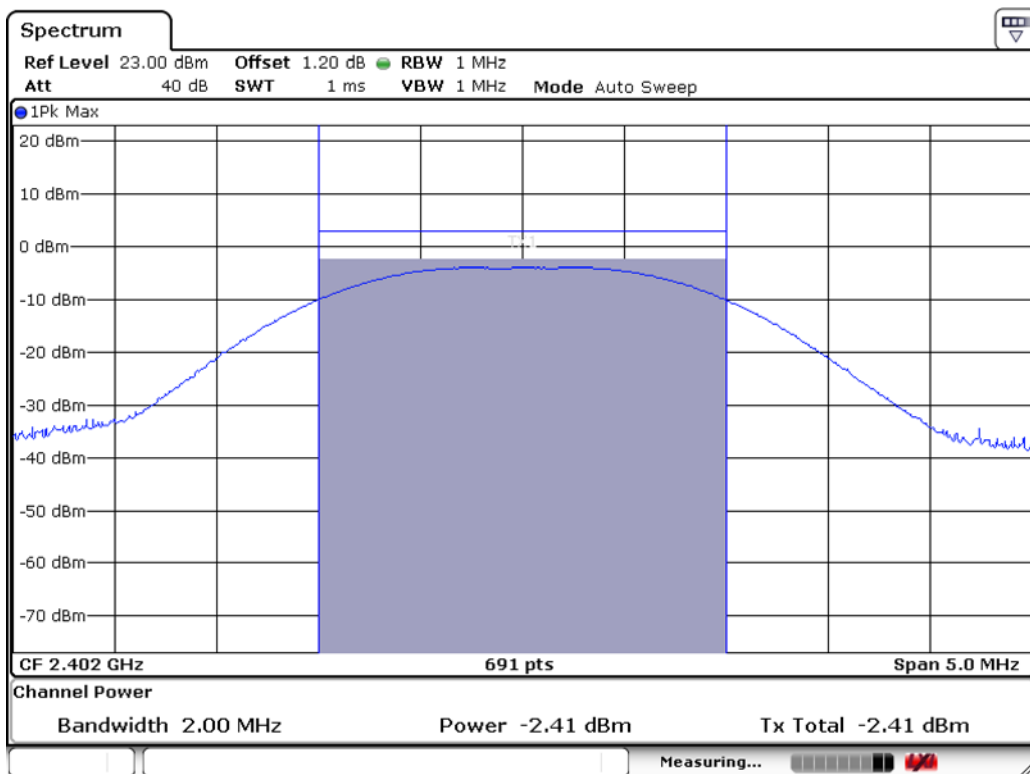

Middle Channel

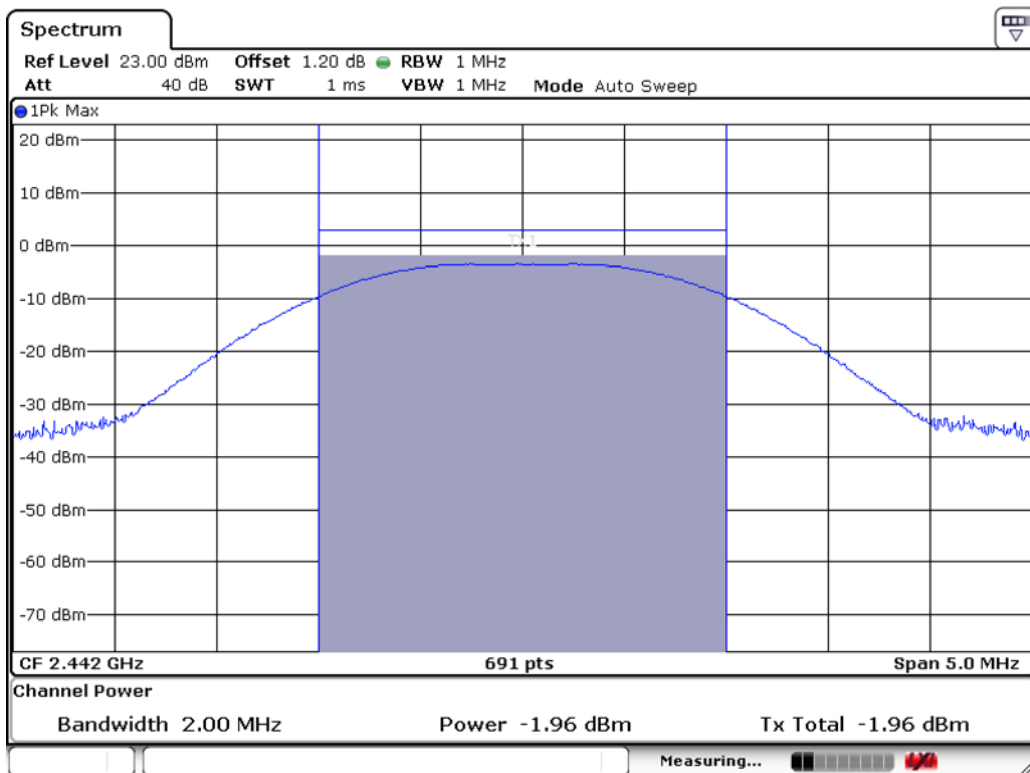

High Channel

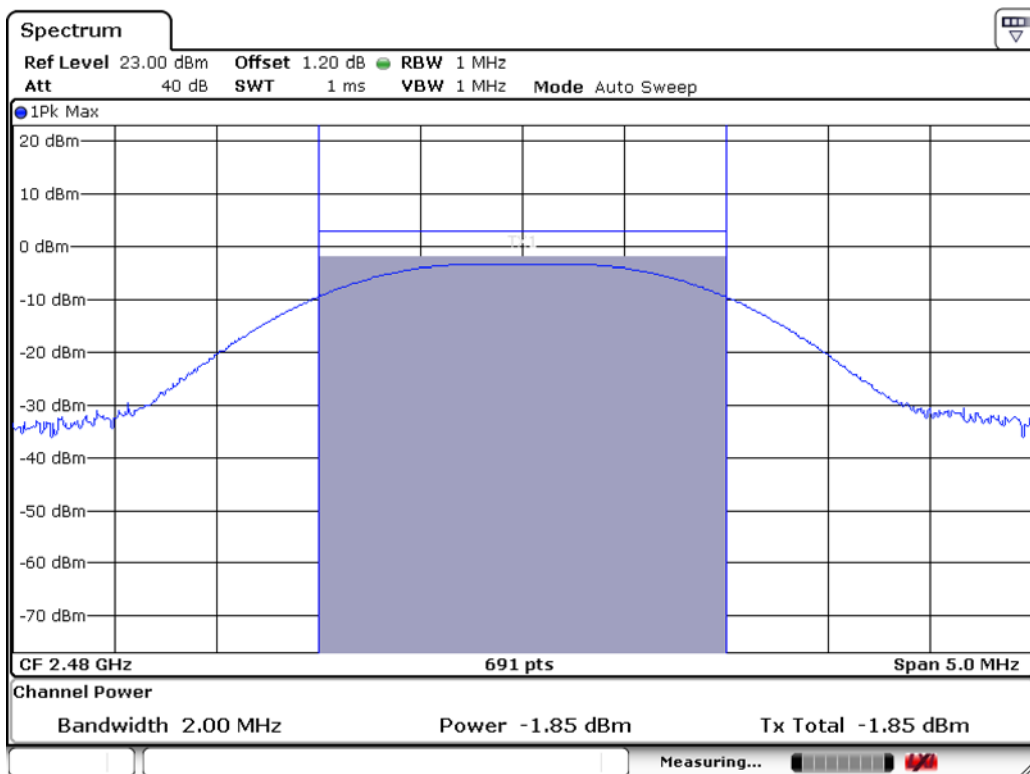

3.2.3 Power Spectral Density

Procedure:

The peak power density is measured with a spectrum analyzer connected to the antenna terminal while the EUT is operating in transmission mode at the appropriate frequencies.

The spectrum analyzer is set to:

RBW = 3 kHz ($3 \text{ kHz} \leq \text{RBW} \leq 100 \text{ kHz}$)

Span = 1.5 times the DTS bandwidth

VBW = 10 kHz (3 X RBW)

Sweep = auto

Detector function = peak

Trace = max hold

Measurement Data : **Complies**

Frequency (MHz)	Test Results	
	dBm/ 3 kHz BW	Result
2402	-21.67	Complies
2442	-21.66	Complies
2480	-21.86	Complies

- See next pages for actual measured spectrum plots.

Minimum Standard:

Power Spectral Density	< 8 dBm @ 3 kHz BW
------------------------	--------------------

Measurement Setup

Same as the Chapter 3.2.1 (Figure 1)

Power Density Measurement Low Channel

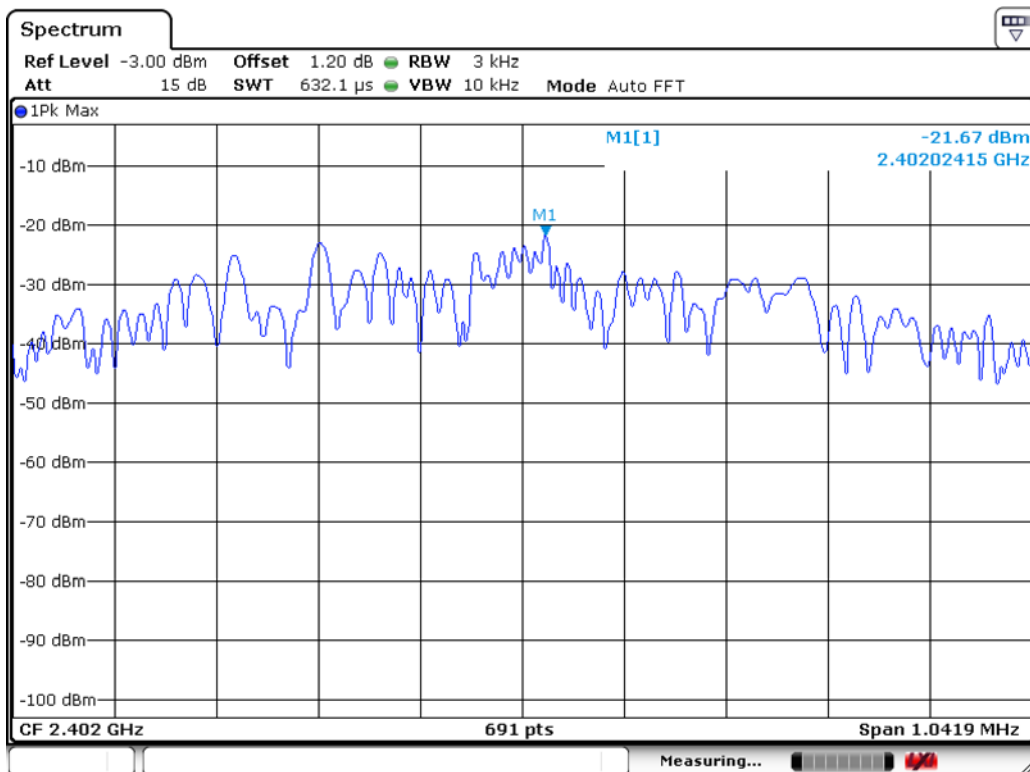

Middle Channel

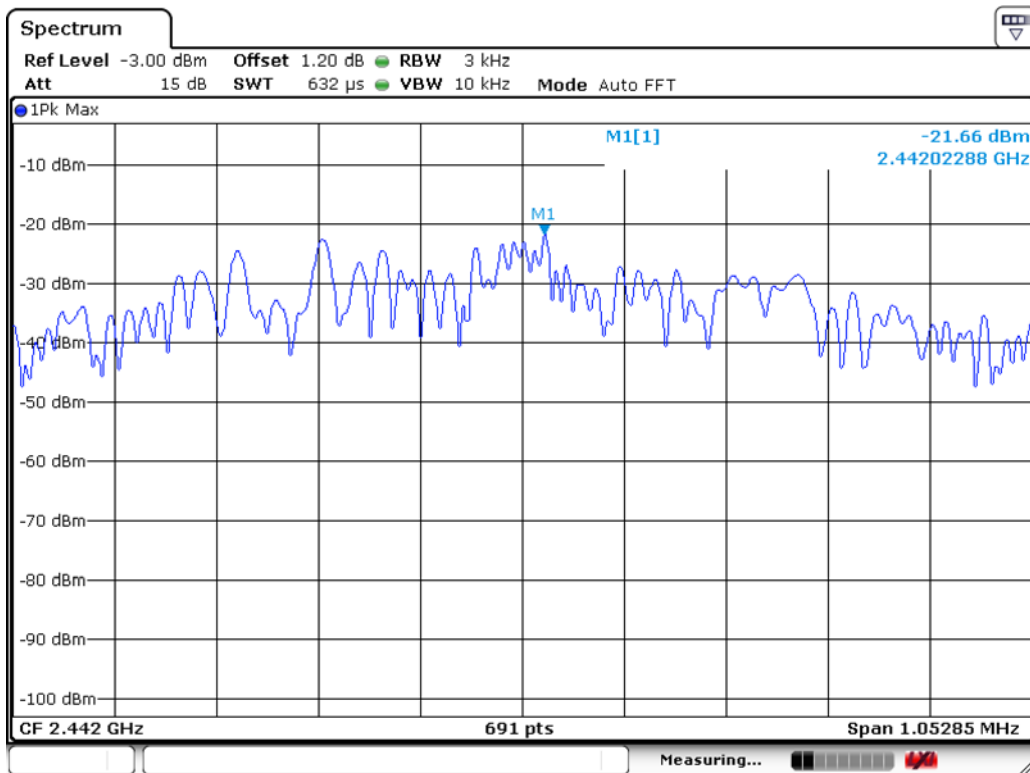

High Channel

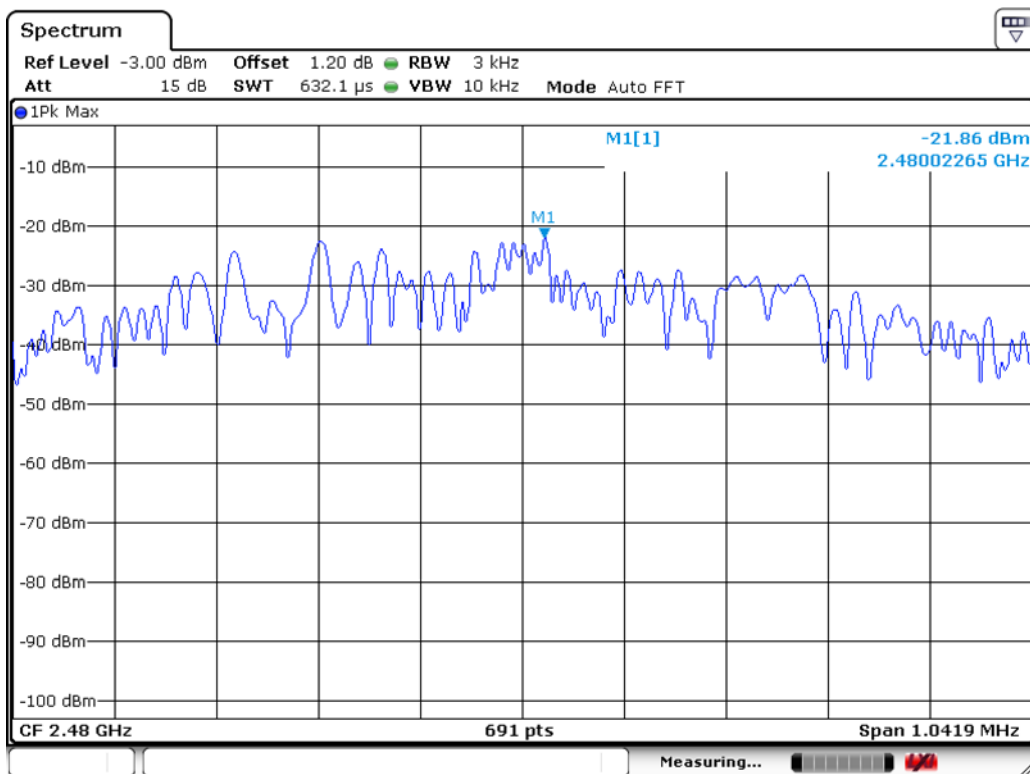

3.2.4 Band Edge

Procedure:

The bandwidth at 20 dB down from the highest inband spectral density is measured with a spectrum analyzer connected to the antenna terminal, while EUT is operating in transmission mode at the appropriate frequencies.

After the trace being stable, Use the marker-to-peak function to measure 20 dB down both sides of the intentional emission.

The spectrum analyzer is set to:

Center frequency = the highest, middle and the lowest channels

RBW = 100 kHz

VBW = 100 kHz

Span = 40 MHz, 100 MHz

Detector function = peak

Trace = max hold

Sweep = auto

Radiated emissions which fall in the restricted bands, as defined in 15.205(a), must also comply with the radiated emission limits specified in 15.209(a)

The spectrum analyzer is set to:

Center frequency = the highest, the lowest channels

PEAK:

RBW = VBW = 1 MHz, Sweep=Auto

Average:

RBW = 1 MHz, VBW = 10 Hz, Sweep=Auto

Measurement Distance:

3 m

Polarization:

Horizontal / Vertical

Measurement Data: Complies

- All conducted emission in any 100 kHz bandwidth outside of the spread spectrum band was at least 20 dB lower than the highest inband spectral density. Therefore the applying equipment meets the requirement.
- See next pages for actual measured spectrum plots.

Minimum Standard:	> 20 dBc
--------------------------	----------

Lower edge

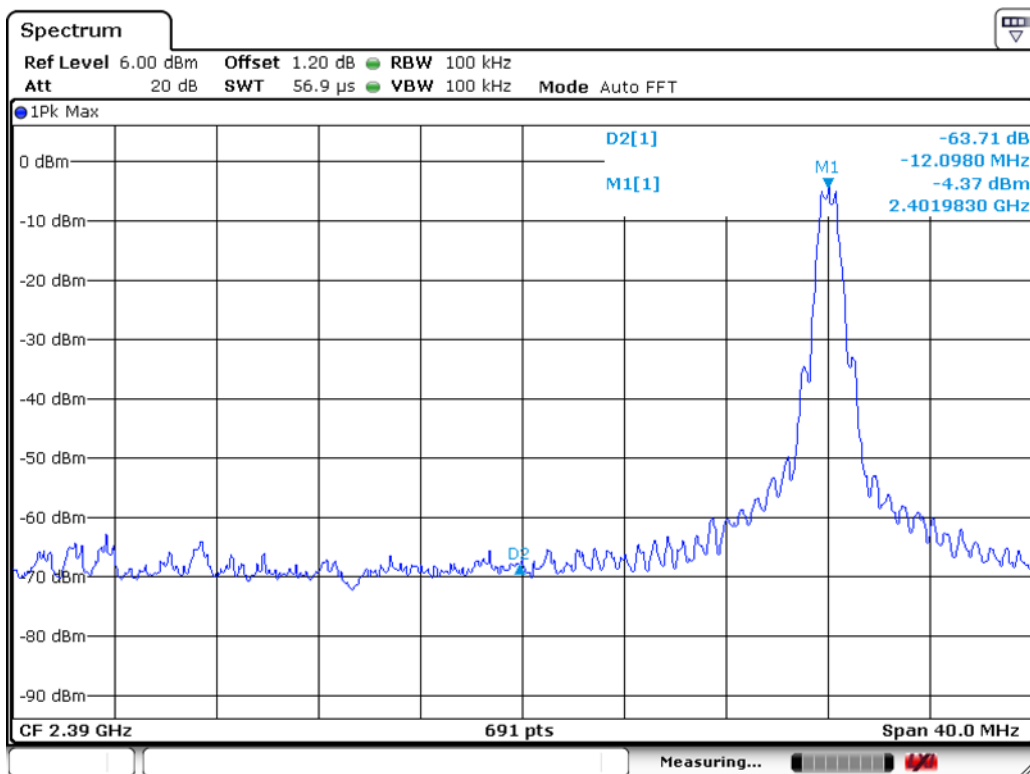

Upper edge

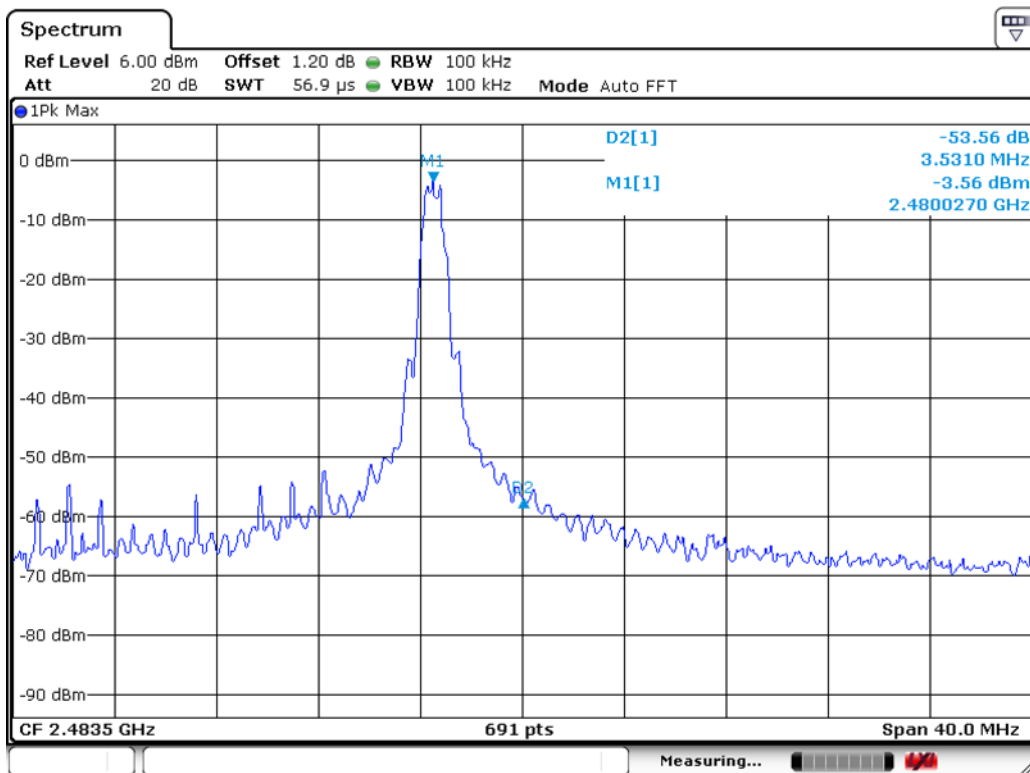

Radiated Band-edges in the restricted band 2310-2390 MHz measurement

Frequency [MHz]	Reading [dBuV/m]		Pol.	Correction Factor	Limits [dBuV/m]		Result [dBuV/m]		Margin [dB]	
	AV	Peak			AV	Peak	AV	Peak	AV	Peak
2389.83	48.81	49.40	H	-9.37	54.0	74.0	39.57	40.16	14.43	33.84
2389.83	50.49	51.38	H	-9.37	54.0	74.0	41.25	42.14	12.75	31.86
2351.74	50.20	51.22	H	-9.38	54.0	74.0	40.96	41.98	13.04	32.02

Radiated Band-edges in the restricted band 2483.5-2500 MHz measurement

Frequency [MHz]	Reading [dBuV/m]		Pol.	Correction Factor	Limits [dBuV/m]		Result [dBuV/m]		Margin [dB]	
	AV	Peak			AV	Peak	AV	Peak	AV	Peak
2490.96	49.24	49.26	H	-9.24	54.0	74.0	40.00	40.02	14.00	33.98
2491.12	48.32	50.67	H	-9.24	54.0	74.0	39.08	41.43	14.92	32.57
2490.84	57.47	57.60	H	-9.24	54.0	74.0	48.23	48.36	5.77	25.64

Note : This EUT was tested in 3 orthogonal positions and the worst-case data was presented

3.2.5 Conducted Spurious Emissions

Procedure:

The test follows KDB558074. The conducted spurious emissions were measured with a spectrum analyzer connected to the antenna terminal, while EUT had its hopping function disabled at the highest, middle and the lowest available channels..

After the trace being stable, set the marker on the peak of any spurious emission recorded.

The spectrum analyzer is set to:

Span = wide enough to capture the peak level of the in-band emission and all spurious emissions

RBW = 100 kHz

Sweep = auto

VBW = 100 kHz

Detector function = peak

Trace = max hold

Measurement Data: Complies

- All conducted emission in any 100 kHz bandwidth outside of the spread spectrum band was at least 20 dB lower than the highest inband spectral density. Therefore the applying equipment meets the requirement.
- See next pages for actual measured spectrum plots.

Minimum Standard:	> 20 dBc
--------------------------	----------

Measurement Setup

Same as the Chapter 3.2.1 (Figure 1)

Unwanted Emission – Low Channel
Frequency Range = 30 MHz ~ 26.5 GHz

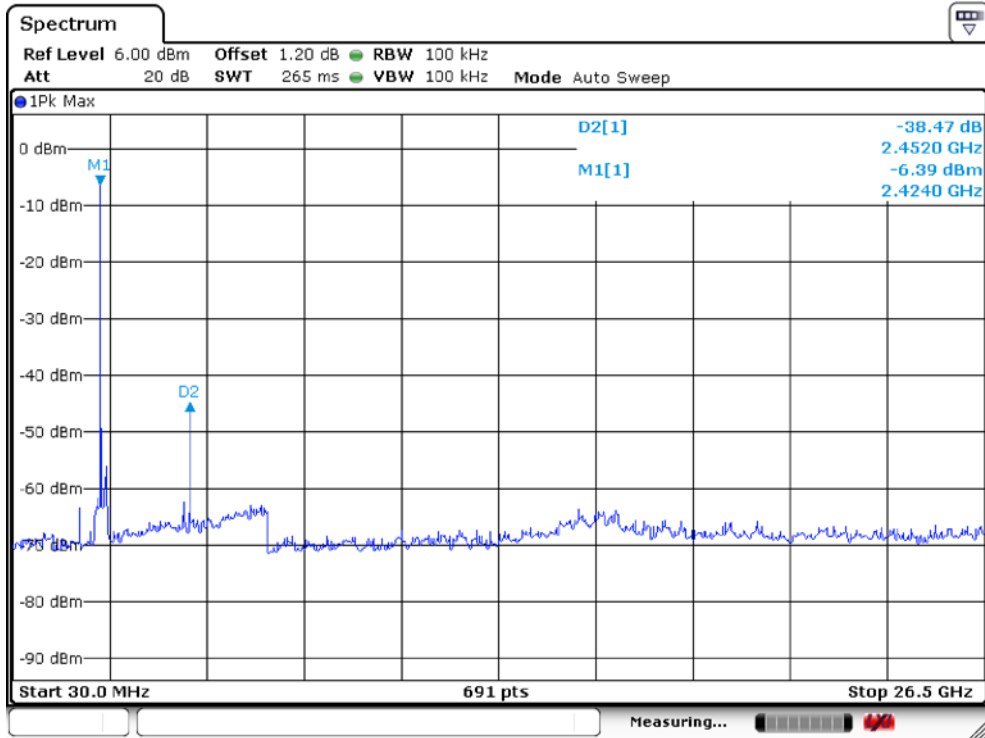

Unwanted Emission – Middle Channel
Frequency Range = 30 MHz ~ 26.5 GHz

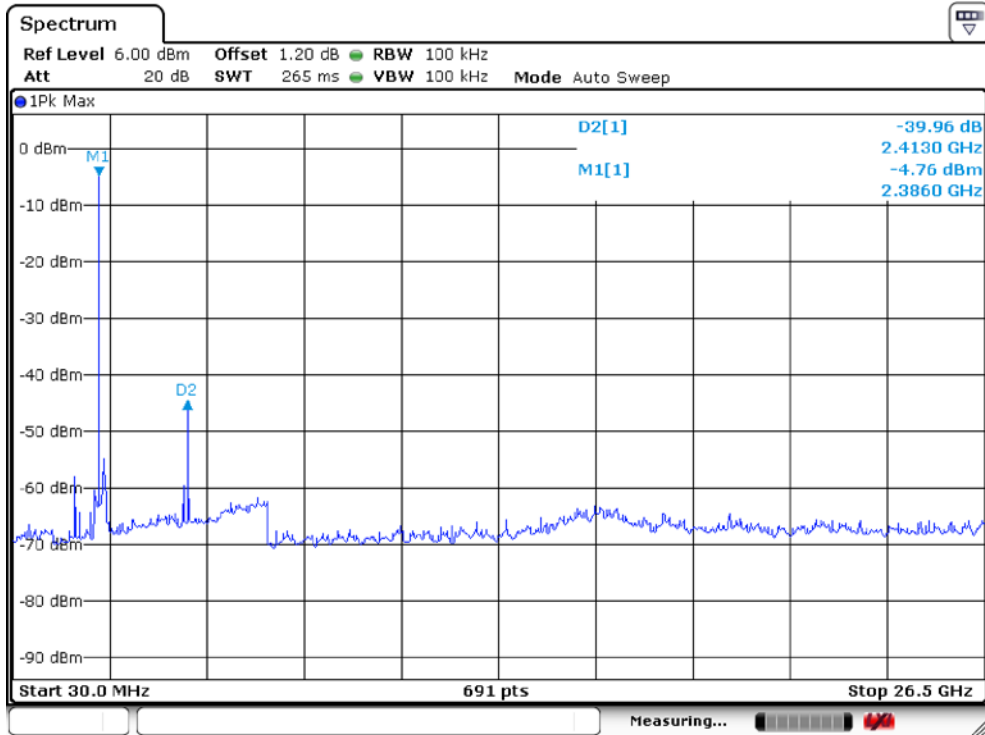

Unwanted Emission – High Channel
Frequency Range = 30 MHz ~ 26.5 GHz

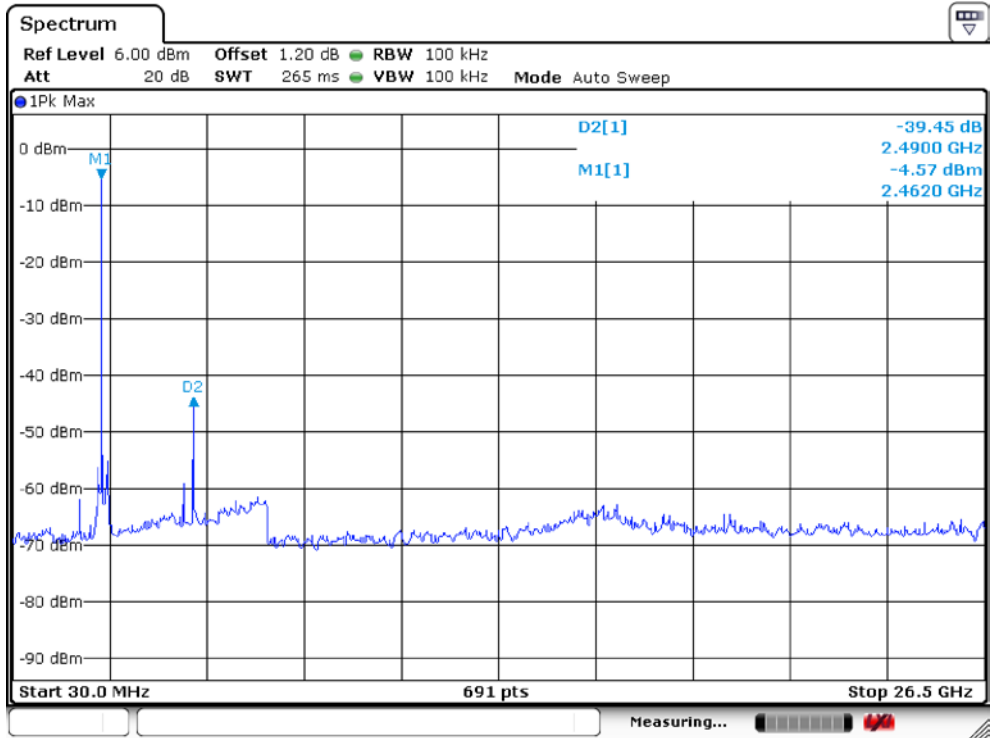

3.2.6 Radiated Spurious Emissions

Procedure:

Radiated emissions from 30 MHz to 25 GHz were measured according to the methods defines in ANSI C63.10-2013.

The EUT is a placed on as turn table. For emissions testing at or below 1 GHz, the table height shall be 0.8 m above the reference ground plane. For emission measurements above 1 GHz, the table height shall be 1.5 m. The turn table shall rotate 360 degrees to determine the position of maximum emission level. EUT is set 3m away from the receiving antenna which varied from 1m to 4m to find out the highest emission. And also, each emission was to be maximized by changing the polarization of receiving antenna both horizontal and vertical. In order to find out the max. emission, the relative positions of this hand-held transmitter (EUT) was rotated through three orthogonal axes and measurement procedures for electric field radiated emissions above 1 GHz the EUT measurement is to be made “while keeping the antenna in the ‘cone of radiation’ from that area and pointed at the area both in azimuth and elevation, with polarization oriented for maximum response.” is still within the 3dB illumination BW of the measurement antenna.

The spectrum analyzer is set to:

Center frequency = the worst channel

Frequency Range = 9 kHz ~ 10th harmonic.

RBW = 100 kHz (30 MHz ~ 1 GHz)

= 1 MHz (1 GHz ~ 10th harmonic)

Span = 100 MHz

Trace = max hold

VBW \geq RBW

Detector function = peak

Sweep = auto

below 30 MHz

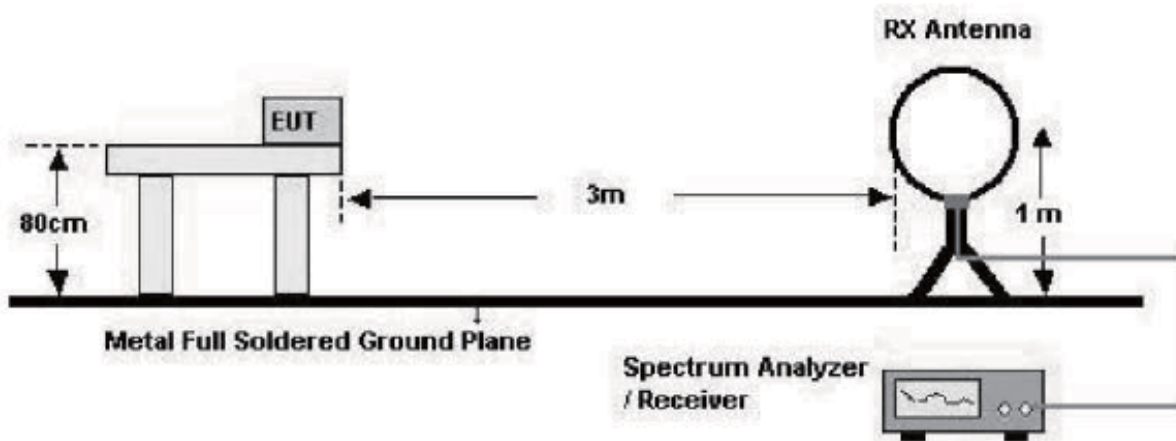

below 1 GHz (30 MHz to 1 GHz)

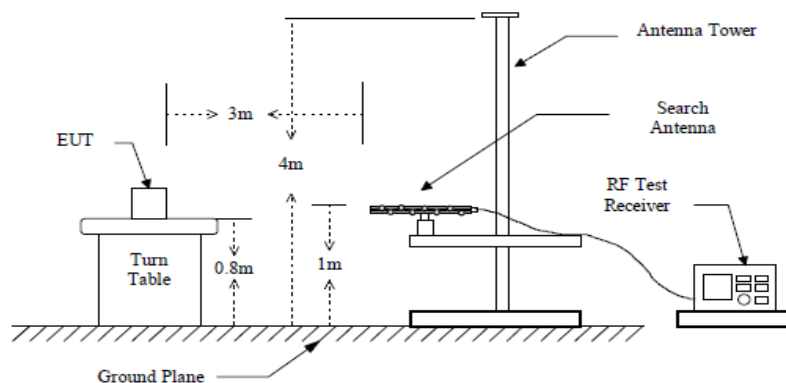

above 1 GHz

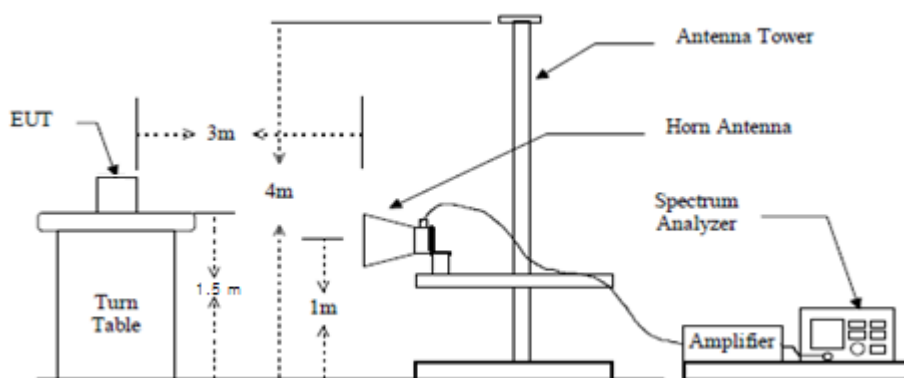

Measurement Data: **Complies**

- See next pages for actual measured data.
- No other emissions were detected at a level greater than 20 dB below limit include from 9 kHz to 30MHz.

Minimum Standard: FCC Part 15.209(a)

Frequency (MHz)	Limit (uV/m) @ 3 m
0.009 ~ 0.490	2400/F(kHz) (@ 300 m)
0.490 ~ 1.705	24000/F(kHz) (@ 30 m)
1.705 ~ 30	30(@ 30 m)
30 ~ 88	100 **
88 ~ 216	150 **
216 ~ 960	200 **
Above 960	500

** Except as provided in 15.209(g), fundamental emissions from intentional radiators operating under this Section shall not be located in the frequency bands 54-72 MHz, 76-88 MHz, 174-216 MHz or 470-806 MHz. However, operation within these frequency bands is permitted under other sections of this Part, e.g. 15.231 and 15.241.

Measurement Data : (Above 1 GHz)

Frequency [MHz]	Reading [dBuV/m] AV / Peak		Pol.	Correction Factor	Limits [dBuV/m] AV/Peak		Result [dBuV/m] AV/Peak		Margin [dB] AV / Peak	
	15710.00	28.60			42.92	H	8.60	54.0	74.0	37.20
16090.00	34.39	51.85	H	9.21	54.0	74.0	43.60	61.06	10.40	12.94
17180.00	36.40	51.84	H	13.63	54.0	74.0	50.03	65.47	3.97	8.53

- No other emissions were detected at a level greater than 20 dB below limit.

Measurement Data: (9 kHz – 30 MHz)

Frequency [MHz]	Reading [dBuV/m] AV / Peak		Pol.	Correction Factor		Limits [dBuV/m] AV / Peak		Result [dBuV/m] AV / Peak		Margin [dB] AV / Peak	
	Antenna	Amp.Gain+Cable		AV / Peak	AV / Peak	AV / Peak	AV / Peak				
-	-	-	-	-	-	-	-	-	-	-	-
-	-	-	-	-	-	-	-	-	-	-	-
*No emissions were detected at a level greater than 20 dB below limit.											
-	-	-	-	-	-	-	-	-	-	-	-

- No other emissions were detected at a level greater than 20 dB below limit.

Radiated Emissions (Below 1 GHz) – Bluetooth(LOW) mode



4, Songjuro 236Beon-gil, yanggi-myeon,
Yongin-si, Gyeonggi-do, Korea
Tel : +82-31-3236008,9
Fax : +82-31-3236010
www.ltalab.com

EUT/Model No.: BHTTT0100 Temp/Humi: 26 / 49

Test Mode : BLE Tested by: H C Kwon

Data: 476 File: C:\Program Files (x86)\e3\1809-1.EM6 (476)

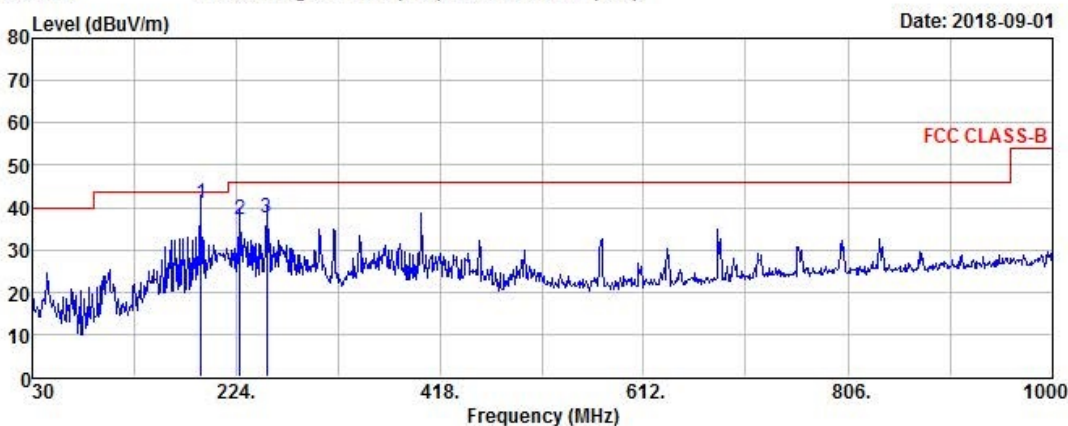

Freq	Reading	C.F	Result	Limit	Margin	Height	Angle	Polarity
MHz	dBuV	dB	QP dBuV/m	dBuV/m	dB	cm	deg	
190.51	59.78	-18.74	41.04	43.50	2.46	119	291	HORIZONTAL
227.63	55.08	-17.84	37.24	46.00	8.76	105	262	HORIZONTAL
253.59	54.11	-16.47	37.64	46.00	8.36	102	288	HORIZONTAL

Remarks: C.F (Correction Factor) = Antenna factor + Cable loss - Preamp gain

Bluetooth(MID) mode



4, Songjuro 236Beon-gil, yanggi-myeon,
Yongin-si, Gyeonggi-do, Korea
Tel : +82-31-3236008,9
Fax : +82-31-3236010
www.ltalab.com

EUT/Model No.: BHTTT0100 Temp/Humi: 26 / 49

Test Mode : BLE Tested by: H C Kwon

Data: 474 File: C:\Program Files (x86)\e3\1809-1.EM6 (474)

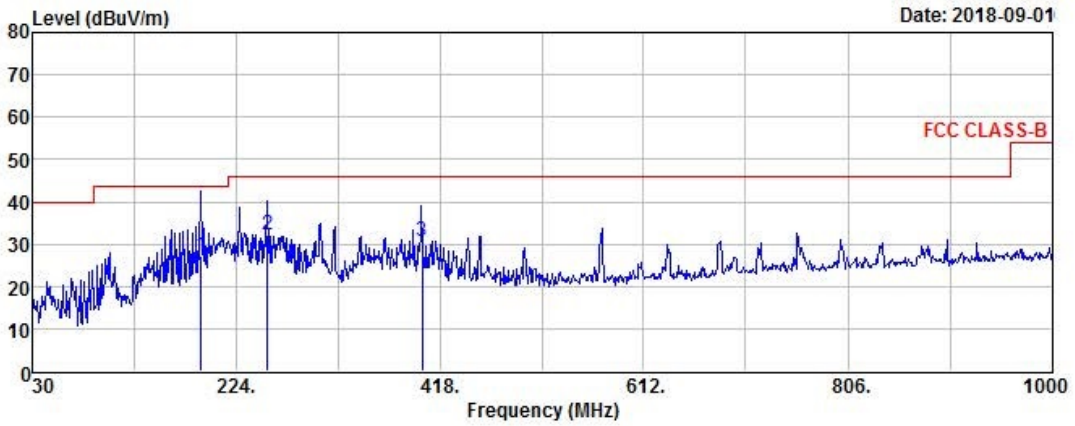

Freq	Reading	C.F	Result	Limit	Margin	Height	Angle	Polarity
MHz	dBuV	dB	QP dBuV/m	dBuV/m	dB	cm	deg	
190.46	46.09	-18.74	27.35	43.50	16.15	398	253	HORIZONTAL
254.23	48.68	-16.44	32.24	46.00	13.76	178	297	HORIZONTAL
401.41	43.20	-12.54	30.66	46.00	15.34	189	283	HORIZONTAL

Remarks: C.F (Correction Factor) = Antenna factor + Cable loss - Preamp gain

Bluetooth(HIGH) mode



4, Songjuro 236Beon-gil, yanggi-myeon,
Yongin-si, Gyeonggi-do, Korea
Tel : +82-31-3236008,9
Fax : +82-31-3236010
www.ltalab.com

EUT/Model No.: BHTTT0100 Temp/Humi: 26 / 49

Test Mode : BLE Tested by: H C Kwon

Data: 471 File: C:\Program Files (x86)\e3\1809-1.EM6 (471)

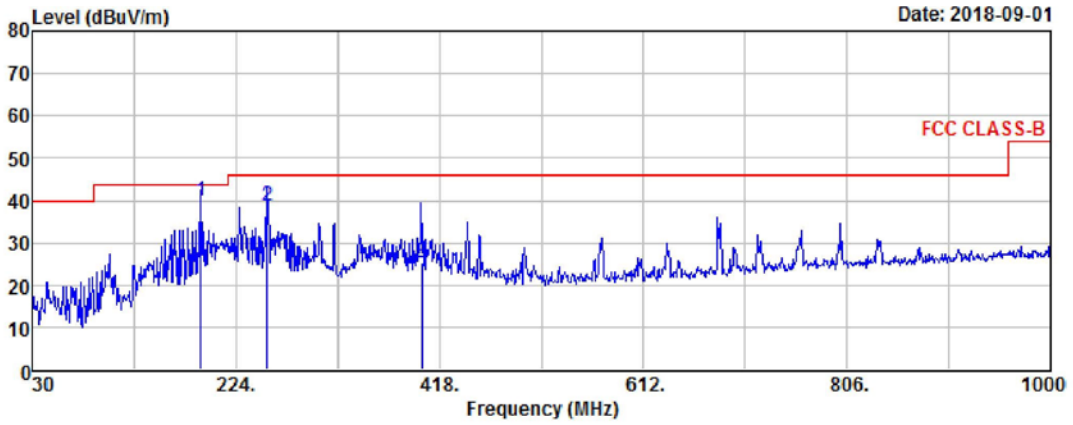

Freq	Reading	C.F	Result	Limit	Margin	Height	Angle	Polarity
MHz	dBuV	dB	QP dBuV/m	dBuV/m	dB	cm	deg	
190.44	58.70	-18.73	39.97	43.50	3.53	132	246	HORIZONTAL
253.97	55.17	-16.45	38.72	46.00	7.28	102	280	HORIZONTAL
401.42	37.62	-12.54	25.08	46.00	20.92	102	75	HORIZONTAL

Remarks: C.F (Correction Factor) = Antenna factor + Cable loss - Preamp gain

Radiated Emissions (Above 1 GHz) – Bluetooth(LOW) mode



4, Songjuro 236Beon-gil, yanggi-myeon,
Yongin-si, Gyeonggi-do, Korea
Tel : +82-31-3236008,9
Fax : +82-31-3236010
www.ltalab.com

EUT/Model No.: BHTTT0100 Temp/Humi: 22 / 48
Test Mode : Wireless mode(LOW) Tested by: H C Kwon

Data: 623 File: C:\Program Files (x86)\e3\1809-1.EM6 (629)

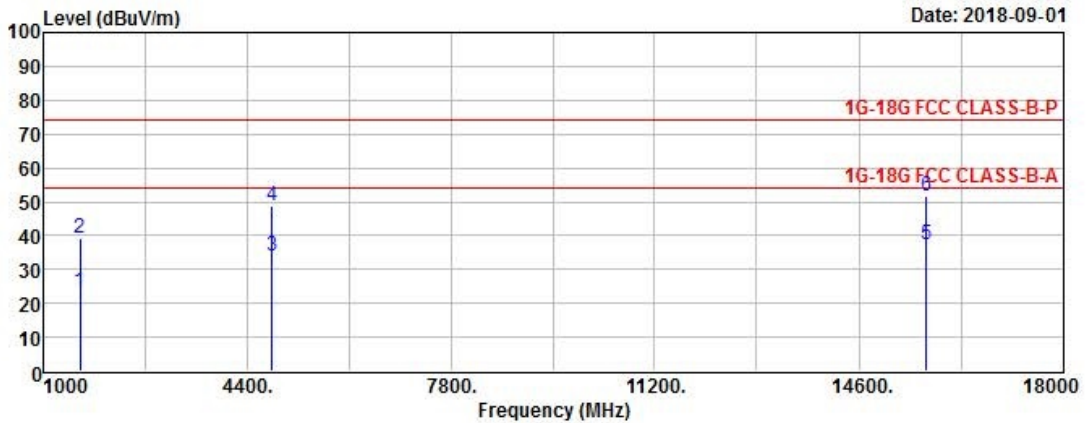

Freq MHz	Reading dBuV	C.F dB	Result QP dBuV/m	Limit dBuV/m	Margin dB	Height cm	Angle deg	Polarity
1609.00	35.59	-12.19	23.40	54.00	30.60	158	265	HORIZONTAL
1609.00	51.20	-12.19	39.01	74.00	34.99	158	265	HORIZONTAL
4817.00	36.28	-2.29	33.99	54.00	20.01	268	124	HORIZONTAL
4817.00	51.03	-2.29	48.74	74.00	25.26	268	124	HORIZONTAL
15710.00	28.60	8.60	37.20	54.00	16.80	364	188	HORIZONTAL
15710.00	42.92	8.60	51.52	74.00	22.48	364	188	HORIZONTAL

Remarks: C.F (Correction Factor) = Antenna factor + Cable loss - Preamp gain



4, Songjuro 236Beon-gil, yanggi-myeon,
 Yongin-si, Gyeonggi-do, Korea
 Tel : +82-31-3236008,9
 Fax : +82-31-3236010
 www.ltalab.com

EUT/Model No.: BHTTT0100 Temp/Humi: 22 / 48
 Test Mode : Wireless mode(LOW) Tested by: H C Kwon

Data: 624 File: C:\Program Files (x86)\e3\1809-1.EM6 (629)

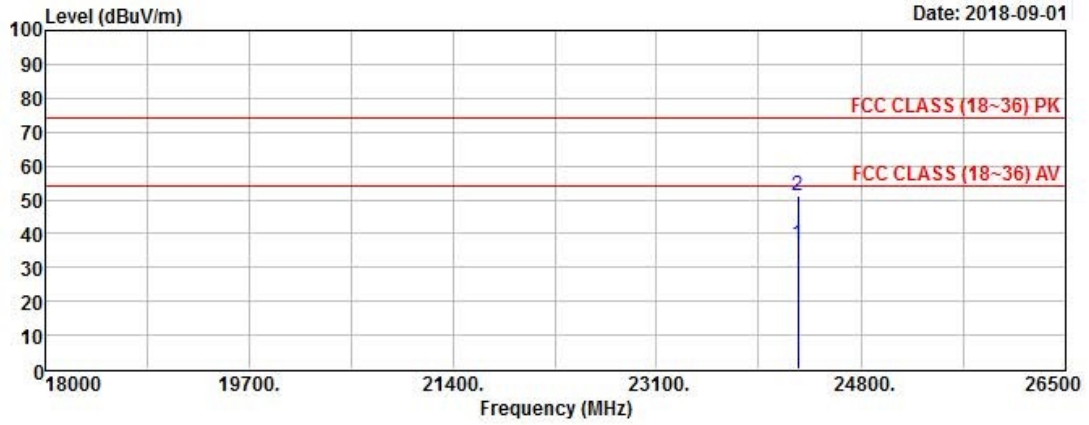

Freq MHz	Reading dBuV	C.F dB	Result QP dBuV/m	Limit dBuV/m	Margin dB	Height cm	Angle deg	Polarity
24280.00	29.79	7.17	36.96	54.00	17.04	210	95	HORIZONTAL
24280.00	43.80	7.17	50.97	74.00	23.03	210	95	HORIZONTAL

Remarks: C.F (Correction Factor) = Antenna factor + Cable loss - Preamp gain

Bluetooth(MID) mode



4, Songjuro 236Beon-gil, yanggi-myeon,
Yongin-si, Gyeonggi-do, Korea
Tel : +82-31-3236008,9
Fax : +82-31-3236010
www.ltalab.com

EUT/Model No.: BHTTT0100 Temp/Humi: 22 / 48
Test Mode : Wireless mode(MID) Tested by: H C Kwon

Data: 629 File: C:\Program Files (x86)\e3\1809-1.EM6 (629)

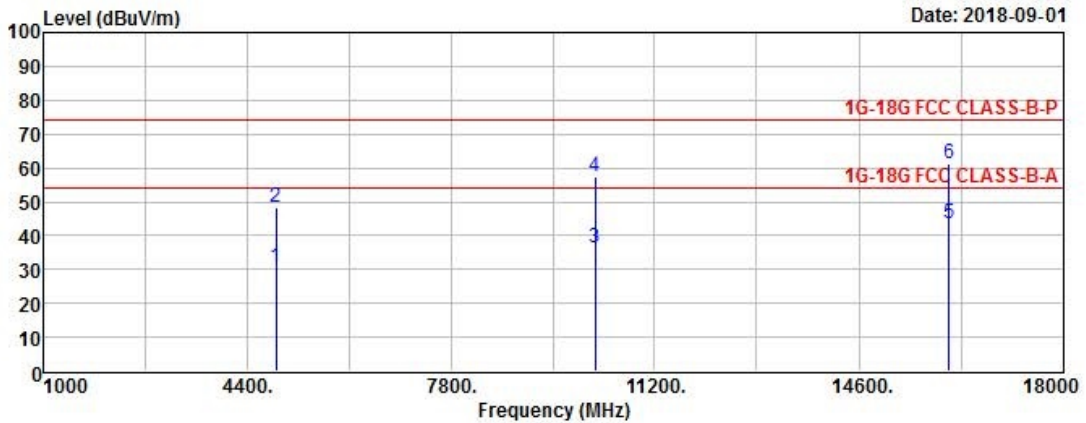

Freq MHz	Reading dBuV	C.F dB	Result QP dBuV/m	Limit dBuV/m	Margin dB	Height cm	Angle deg	Polarity
4882.00	32.85	-2.13	30.72	54.00	23.28	268	85	HORIZONTAL
4882.00	50.42	-2.13	48.29	74.00	25.71	268	85	HORIZONTAL
10210.00	31.38	4.81	36.19	54.00	17.81	166	354	HORIZONTAL
10210.00	52.45	4.81	57.26	74.00	16.74	166	354	HORIZONTAL
16090.00	34.39	9.21	43.60	54.00	10.40	199	54	HORIZONTAL
16090.00	51.85	9.21	61.06	74.00	12.94	199	54	HORIZONTAL

Remarks: C.F (Correction Factor) = Antenna factor + Cable loss - Preamp gain



4, Songjuro 236Beon-gil, yanggi-myeon,
Yongin-si, Gyeonggi-do, Korea
Tel : +82-31-3236008,9
Fax : +82-31-3236010
www.ltalab.com

EUT/Model No.: BHTTT0100 Temp/Humi: 22 / 48
Test Mode : Wireless mode(MID) Tested by: H C Kwon

Data: 625 File: C:\Program Files (x86)\e3\1809-1.EM6 (629)

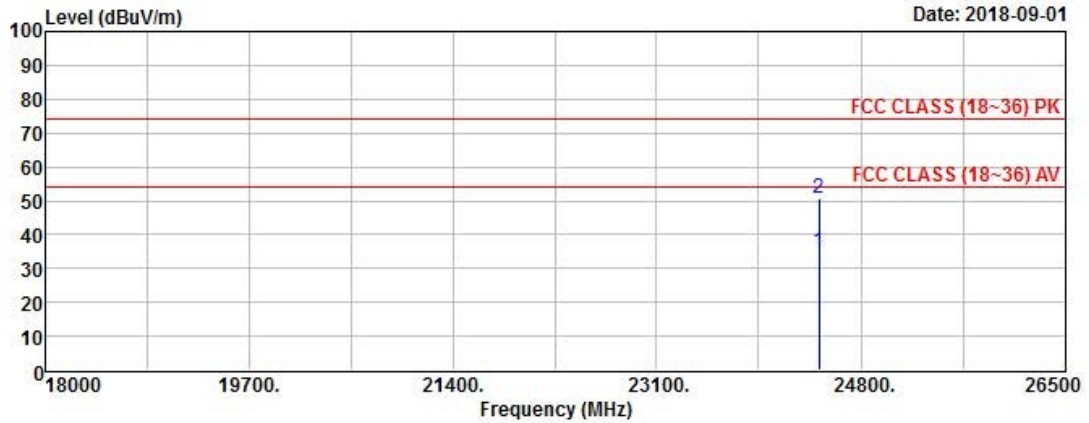

Freq MHz	Reading dBuV	C.F dB	Result QP dBuV/m	Limit dBuV/m	Margin dB	Height cm	Angle deg	Polarity
24454.00	27.58	7.15	34.73	54.00	19.27	189	66	HORIZONTAL
24454.00	43.52	7.15	50.67	74.00	23.33	189	66	HORIZONTAL

Remarks: C.F (Correction Factor) = Antenna factor + Cable loss - Preamp gain

Bluetooth(HIGH) mode



4, Songjuro 236Beon-gil, yanggi-myeon,
Yongin-si, Gyeonggi-do, Korea
Tel : +82-31-3236008,9
Fax : +82-31-3236010
www.ltalab.com

EUT/Model No.: BHTTT0100 Temp/Humi: 22 / 48
Test Mode : Wireless mode(HIGH) Tested by: H C Kwon

Data: 628 File: C:\Program Files (x86)\e3\1809-1.EM6 (629)

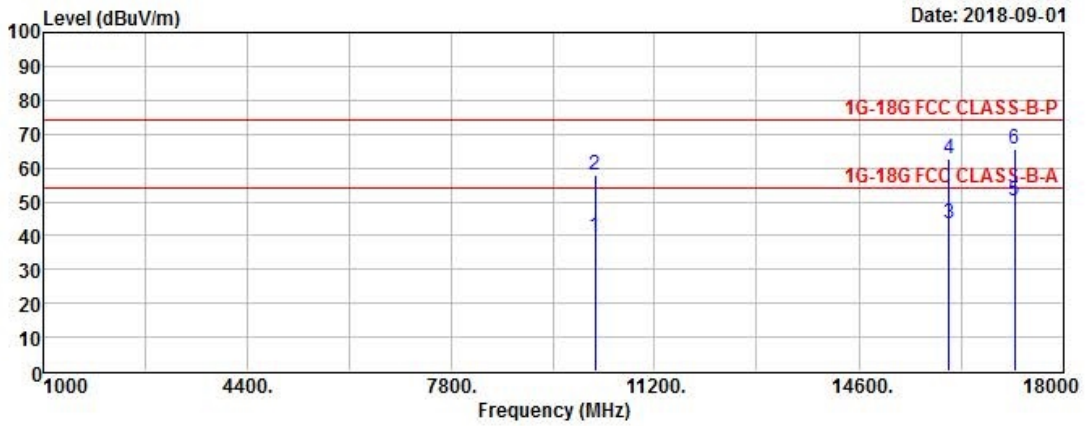

Freq MHz	Reading dBuV	C.F dB	Result QP dBuV/m	Limit dBuV/m	Margin dB	Height cm	Angle deg	Polarity
10210.00	34.68	4.81	39.49	54.00	14.51	155	314	HORIZONTAL
10210.00	52.95	4.81	57.76	74.00	16.24	155	314	HORIZONTAL
16090.00	34.26	9.21	43.47	54.00	10.53	268	141	HORIZONTAL
16090.00	53.48	9.21	62.69	74.00	11.31	268	141	HORIZONTAL
17180.00	36.40	13.63	50.03	54.00	3.97	155	236	HORIZONTAL
17180.00	51.84	13.63	65.47	74.00	8.53	155	236	HORIZONTAL

Remarks: C.F (Correction Factor) = Antenna factor + Cable loss - Preamp gain



4, Songjuro 236Beon-gil, yanggi-myeon,
Yongin-si, Gyeonggi-do, Korea
Tel : +82-31-3236008,9
Fax : +82-31-3236010
www.ltalab.com

EUT/Model No.: BHTTT0100 Temp/Humi: 22 / 48
Test Mode : Wireless mode(HIGH) Tested by: H C Kwon

Data: 626 File: C:\Program Files (x86)\e3\1809-1.EM6 (629)

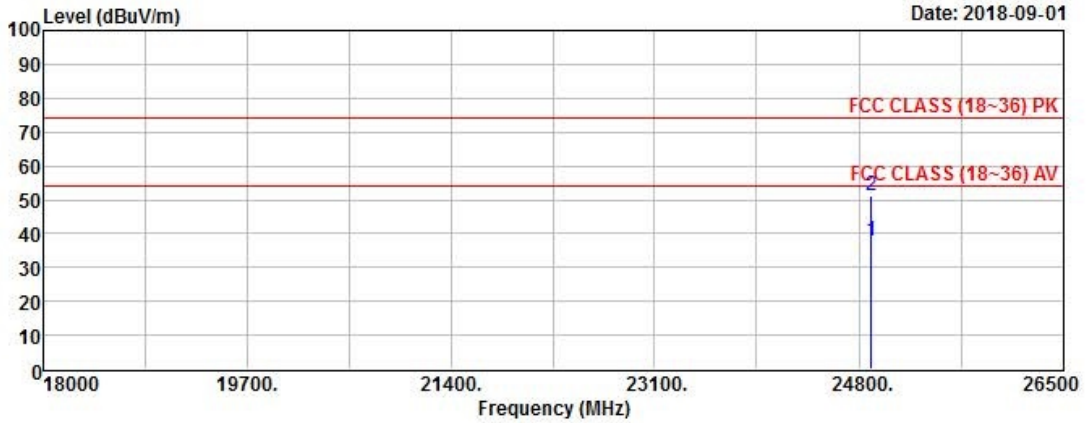

Freq MHz	Reading dBuV	C.F dB	Result QP dBuV/m	Limit dBuV/m	Margin dB	Height cm	Angle deg	Polarity
24895.00	30.59	7.11	37.70	54.00	16.30	345	264	HORIZONTAL
24895.00	43.88	7.11	50.99	74.00	23.01	345	264	HORIZONTAL

Remarks: C.F (Correction Factor) = Antenna factor + Cable loss - Preamp gain

3.2.7 AC Conducted Emissions

Procedure:

The conducted emissions are measured in the shielded room with a spectrum analyzer in peak hold. While the measurement, EUT had its hopping function disabled at the middle channels in line with Section 15.31(m). Emissions closest to the limit are measured in the quasi-peak mode (QP) with the tuned receiver using a bandwidth of 9 kHz. The emissions are maximized further by cable manipulation and Exerciser operation. The highest emissions relative to the limit are listed.

Minimum Standard: FCC Part 15.207(a) / EN 55022

Measurement Data: Complies

Class B

Frequency Range	quasi-peak	Average
0.15 ~ 0.5	66 to 56 *	56 to 46 *
0.5 ~ 5	56	46
5 ~ 30	60	50

* Decreases with the logarithm of the frequency



4, Songjuro 236 Beon-gil, Yangji-myeon
 Cheoin-gu, Youngin-si, Gyeonggi-do
 449-822 Korea
 Tel:+82-31-3236008,9
 Fax:+82-31-3236010

EUT / Model No. : BHTTT0100 Phase : LINE
 Test Mode : Charging mode Test Power : 120 / 60
 Temp. / Humi. : 26 / 51 Test Engineer : H C KWON

Data: 880 File: D:\Conducted Data\2018\LTA_Conduction_2018_9.EM6 (883)

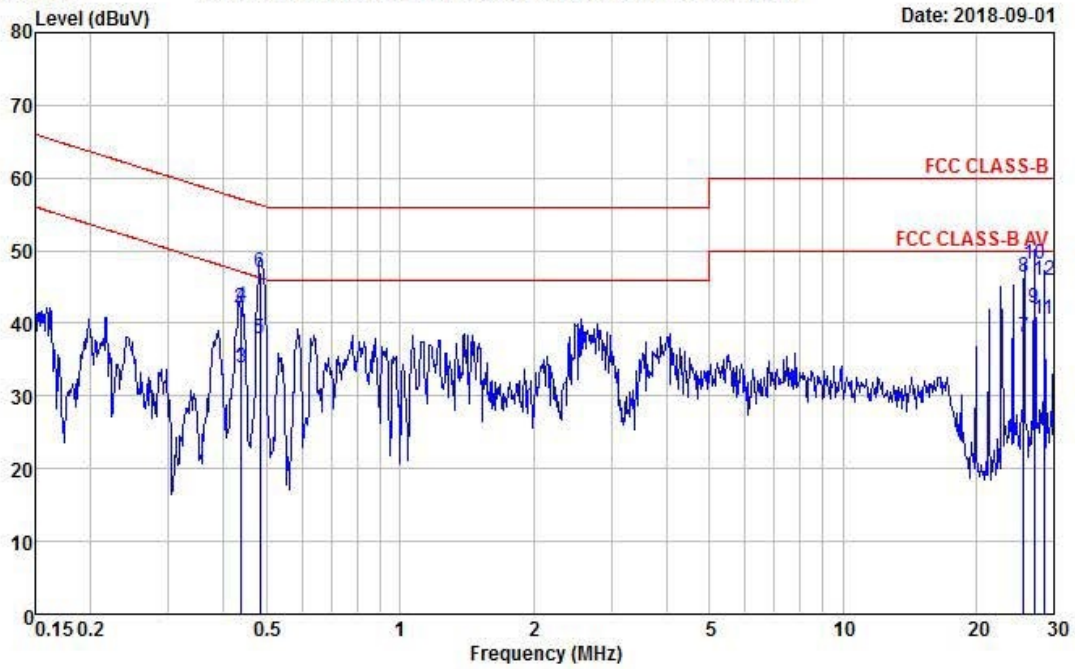

Freq	RD	RD	C.F	Result	Result	Limit	Limit	Margin	Margin
MHz	QP	AV	dB	QP	AV	QP	AV	QP	AV
0.436	22.57	14.39	19.50	42.07	33.89	57.14	47.14	15.07	13.25
0.437	22.74	14.30	19.50	42.24	33.80	57.11	47.11	14.87	13.31
0.484	27.58	18.45	19.50	47.08	37.95	56.28	46.28	9.20	8.33
25.618	25.86	17.76	20.44	46.30	38.20	60.00	50.00	13.70	11.80
27.045	27.70	21.62	20.42	48.12	42.04	60.00	50.00	11.88	7.96
28.467	25.60	20.13	20.41	46.01	40.54	60.00	50.00	13.99	9.46

Remarks: C.F (Correction Factor) = Insertion loss + Cable loss + Pulse Limiter



4, Songjuro 236 Beon-gil, Yangji-myeon
 Cheoin-gu, Youngin-si, Gyeonggi-do
 449-822 Korea
 Tel:+82-31-3236008,9
 Fax:+82-31-3236010

EUT / Model No. : BHTTT0100 Phase : NEUTRAL
 Test Mode : Charging mode Test Power : 120 / 60
 Temp. / Humi. : 26 / 51 Test Engineer : H C KWON

Data: 883 File: D:\Conducted Data\2018\LTA_Conduction_2018_9.EM6 (883)

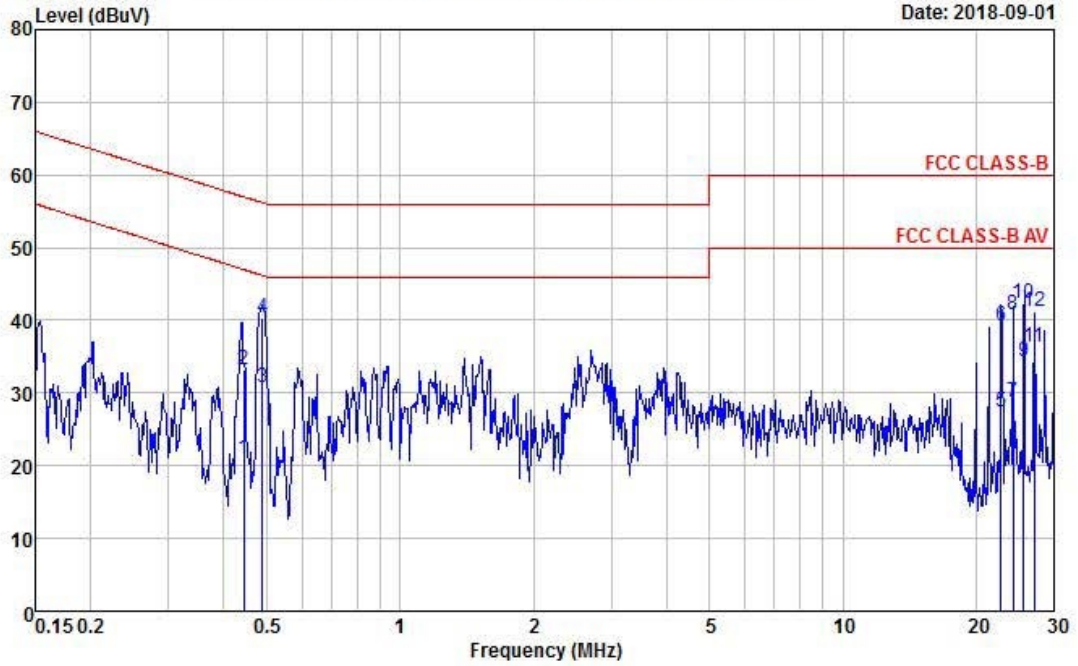

Freq	RD	RD	C.F	Result	Result	Limit	Limit	Margin	Margin
MHz	QP	AV	dB	QP	AV	QP	AV	QP	AV
	dBuV	dBuV		dBuV	dBuV	dBuV	dBuV	dB	dB
0.444	13.74	1.53	19.49	33.23	21.02	56.98	46.98	23.75	25.96
0.488	20.90	11.20	19.49	40.39	30.69	56.19	46.19	15.80	15.50
22.778	18.72	6.99	20.45	39.17	27.44	60.00	50.00	20.83	22.56
24.203	20.16	8.13	20.56	40.72	28.69	60.00	50.00	19.28	21.31
25.628	21.70	13.76	20.54	42.24	34.30	60.00	50.00	17.76	15.70
27.052	20.81	15.84	20.53	41.34	36.37	60.00	50.00	18.66	13.63

Remarks: C.F (Correction Factor) = Insertion loss + Cable loss + Pulse Limiter

APPENDIX
TEST EQUIPMENT USED FOR TESTS

	Use	Description	Model No.	Serial No.	Manufacturer	Interval	Last Cal. Date
1	■	Signal Analyzer (9 kHz ~ 30 GHz)	FSV30	100757	R&S	1 year	2017-09-07
2		SYNTHESIZED CW GENERATOR	83711B	US34490456	HP	1 year	2018-03-19
3		Attenuator (3 dB)	8491A	37822	HP	1 year	2017-09-07
4		Attenuator (10 dB)	8491A	63196	HP	1 year	2017-09-07
5	■	EMI Test Receiver (~7 GHz)	ESCI7	100722	R&S	1 year	2017-09-07
6	■	RF Amplifier (~1.3 GHz)	8447D OPT 010	2944A07684	HP	1 year	2017-09-07
7	■	RF Amplifier (1~26.5 GHz)	8449B	3008A02126	HP	1 year	2018-03-21
8	■	Horn Antenna (1~18 GHz)	3115	00114105	ETS	2 year	2018-08-04
9		DRG Horn (Small)	3116B	81109	ETS-Lindgren	2 year	2018-05-03
10	■	DRG Horn (Small)	3116B	133350	ETS-Lindgren	2 year	2018-05-03
11	■	TRILOG Antenna	VULB 9160	9160-3237	SCHWARZBECK	2 year	2017-04-17
12		Temp.Humidity Data Logger	SK-L200TH II A	00801	SATO	1 year	2017-11-23
13		DC Power Supply	6674A	3637A01657	Agilent	-	-
14	■	Power Meter	EPM-441A	GB32481702	HP	1 year	2018-03-20
15	■	Power Sensor	8481A	3318A94972	HP	1 year	2017-12-30
16		Audio Analyzer	8903B	3729A18901	HP	1 year	2017-09-07
17		Modulation Analyzer	8901B	3749A05878	HP	1 year	2017-09-07
18		TEMP & HUMIDITY Chamber	YJ-500	LTAS06041	JinYoung Tech	1 year	2017-09-07
19		Stop Watch	HS-3	812Q08R	CASIO	2 year	2018-03-21
20		LISN	KNW-407	8-1430-1	Kyoritsu	1 year	2017-09-07
21		Two-Lime V-Network	ESH3-Z5	893045/017	R&S	1 year	2018-03-20
22		Highpass Filter	WHKX1.5/15G-10SS	74	Wainwright Instruments	1 year	2018-03-20
23		Highpass Filter	WHKX3.0/18G-10SS	118	Wainwright Instruments	1 year	2018-03-20
24		OSP120 BASE UNIT	OSP120	101230	R&S	1 year	2018-03-21
25	■	Signal Generator(100 kHz ~ 40 GHz)	SMB100A	177621	R&S	1 year	2018-03-20
26		Vector Signal Generator(9kHz ~ 6 GHz)	SMBV100A	255081	R&S	1 year	2018-03-20
27		Signal Analyzer (10 Hz ~ 40 GHz)	FSV40	101367	R&S	1 year	2018-03-21