



Shenzhen CTL Testing Technology Co., Ltd.
Tel: +86-755-89486194 E-mail: ctl@ctl-lab.com

TEST REPORT

FOR FCC PART 15 SUBPART C 15.239

Report Reference No.....: CTL2106172061-WF02

Compiled by: Happy Guo
(position+printed name+signature) (File administrators)

Tested by: Gary Gao
(position+printed name+signature) (Test Engineer)

Approved by: Ivan Xie
(position+printed name+signature) (Manager)



Product Name.....: Car FM Transmitter

Model/Type reference.....: C81

List Model(s).....: SW-XC652, SW-XC653, C81L,C81Q, C80, C80L

Trade Mark.....: N/A

FCC ID.....: 2AJ5B-C81

Applicant's name.....: SAGE HUMAN ELECTRONICS INTERNATIONAL CO., LTD.

Address of applicant.....: 4F., A Building, Rongli Industrial Park, No.2 Guiyuan Rd. Guihua Community, Guanlan Town, Longhua New Dist. Shenzhen, China.

Test Firm.....: Shenzhen CTL Testing Technology Co., Ltd.

Address of Test Firm.....: Floor 1-A, Baisha Technology Park, No.3011, Shahexi Road, Nanshan District, Shenzhen, China 518055

Test specification.....:

Standard.....: FCC Part 15.239: Operation in the band 88–108 MHz.

TRF Originator.....: Shenzhen CTL Testing Technology Co., Ltd.

Master TRF.....: Dated 2011-01

Date of receipt of test item.....: Aug. 06, 2021

Date of sampling.....: Aug. 06, 2021

Date of Test Date.....: Aug. 06, 2021-Aug. 31, 2021

Date of Issue.....: Aug. 31, 2021

Result.....: Pass

Shenzhen CTL Testing Technology Co., Ltd. All rights reserved.

This publication may be reproduced in whole or in part for non-commercial purposes as long as the Shenzhen CTL Testing Technology Co., Ltd. is acknowledged as copyright owner and source of the material. Shenzhen CTL Testing Technology Co., Ltd. takes no responsibility for and will not assume liability for damages resulting from the reader's interpretation of the reproduced material due to its placement and context.

TEST REPORT

Test Report No. :	CTL2106172061-WF02	Aug. 31, 2021
		Date of issue

Equipment under Test : Car FM Transmitter

Sample No : CTL210617206-1-S001

Model /Type : C81

Listed Models : SW-XC652, SW-XC653, C81L,C81Q, C80, C80L

Applicant : **SAGE HUMAN ELECTRONICS INTERNATIONAL CO., LTD.**

Address : 4F., A Building, Rongli Industrial Park, No.2 Guiyuan Rd. Guihua Community, Guanlan Town, Longhua New Dist. Shenzhen, China.

Manufacturer : **SAGE HUMAN ELECTRONICS INTERNATIONAL CO., LTD.**

Address : 4F., A Building, Rongli Industrial Park, No.2 Guiyuan Rd. Guihua Community, Guanlan Town, Longhua New Dist. Shenzhen, China.

Test result	Pass *
--------------------	---------------

* In the configuration tested, the EUT complied with the standards specified page 5.

Note: The device (Product Name: Car FM Transmitter) Models Name: C81, SW-XC652, SW-XC653, C81L,C81Q, C80, C80L have same electrical, PCB and BOM, only the colour and model's names are different for marketing requirements.

The test report merely corresponds to the test sample.

It is not permitted to copy extracts of these test result without the written permission of the test laboratory.

Table of Contents

Page

1. SUMMARY.....5

1.1. TEST STANDARDS..... 5

1.2. TEST DESCRIPTION..... 5

1.3. TEST FACILITY..... 6

1.4. STATEMENT OF THE MEASUREMENT UNCERTAINTY..... 6

2. GENERAL INFORMATION..... 8

2.1. ENVIRONMENTAL CONDITIONS..... 8

2.2. GENERAL DESCRIPTION OF EUT..... 8

2.3. DESCRIPTION OF TEST MODES AND TEST FREQUENCY..... 8

2.4. EQUIPMENTS USED DURING THE TEST..... 9

2.5. RELATED SUBMITTAL(S) / GRANT(S)..... 9

2.6. MODIFICATIONS..... 9

3. TEST CONDITIONS AND RESULTS.....10

3.1. CONDUCTED EMISSIONS TEST..... 10

3.2. RADIATED EMISSIONS..... 12

3.3. OCCUPIED BANDWIDTH..... 17

3.4. ANTENNA REQUIREMENT..... 19

4. TEST SETUP PHOTOS OF THE EUT.....20

5. EXTERNAL AND INTERNAL PHOTOS OF THE EUT.....21

1. SUMMARY

1.1. TEST STANDARDS

The tests were performed according to following standards:

[FCC Rules Part 15.239](#): Operation in the band 88–108 MHz.

[ANSI C63.10:2020](#) : American National Standard for Testing Unlicensed Wireless Devices

[ANSI C63.4: 2014](#): –American National Standard for Methods of Measurement of Radio-Noise Emissions from Low-Voltage Electrical and Electronic Equipment in the Range of 9 kHz to 40GHz
Range of 9 kHz to 40GHz

1.2. Test Description

FCC PART 15.239		
FCC Part 15.239(b)	Field Strength of Fundamental	PASS
FCC Part 15.209/15.239(c)	Spurious Emission	PASS
FCC Part 15.215	20dB bandwidth	PASS
FCC Part 15.207	Conducted Emission	N/A ^{Note1}
FCC Part 15.203	Antenna Requirement	PASS

Note1:Not applicable to this device, for it is powered by car battery.

1.3. Test Facility

1.3.1 Address of the test laboratory

Shenzhen CTL Testing Technology Co., Ltd.
Floor 1-A, Baisha Technology Park, No. 3011, Shahexi Road, Nanshan, Shenzhen 518055 China

There is one 3m semi-anechoic chamber and two line conducted labs for final test. The Test Sites meet the requirements in documents ANSI C63.4 and CISPR 22/EN 55022 requirements.

1.3.2 Laboratory accreditation

The test facility is recognized, certified, or accredited by the following organizations:

CNAS-Lab Code: L7497

Shenzhen CTL Testing Technology Co., Ltd. has been assessed and proved to be in compliance with CNAS-CL01 Accreditation Criteria for Testing and Calibration Laboratories (identical to ISO/IEC 17025: 2005 General Requirements) for the Competence of Testing and Calibration Laboratories.

A2LA-Lab Cert. No. 4343.01

Shenzhen CTL Testing Technology Co., Ltd, EMC Laboratory has been accredited by A2LA for technical competence in the field of electrical testing, and proved to be in compliance with ISO/IEC 17025: 2005 General Requirements for the Competence of Testing and Calibration Laboratories and any additional program requirements in the identified field of testing.

IC Registration No.: 9618B

CAB identifier: CN0041

The 3m alternate test site of Shenzhen CTL Testing Technology Co., Ltd. EMC Laboratory has been registered by Innovation, Science and Economic Development Canada to test to Canadian radio equipment requirements with Registration No.: 9618B on Jan. 22, 2019.

FCC-Registration No.: 399832

Designation No.: CN1216

Shenzhen CTL Testing Technology Co., Ltd. EMC Laboratory has been registered and fully described in a report filed with the (FCC) Federal Communications Commission. The acceptance letter from the FCC is maintained in our files. Registration 399832, December 08, 2017.

1.4. Statement of the measurement uncertainty

The data and results referenced in this document are true and accurate. The reader is cautioned that there may be errors within the calibration limits of the equipment and facilities. The measurement uncertainty was calculated for all measurements listed in this test report acc. to CISPR 16 - 4 „Specification for radio disturbance and immunity measuring apparatus and methods – Part 4: Uncertainty in EMC Measurements“ and is documented in the Shenzhen CTL Testing Technology Co., Ltd. quality system acc. to DIN EN ISO/IEC 17025. Furthermore, component and process variability of devices similar to that tested may result in additional deviation. The manufacturer has the sole responsibility of continued compliance of the device.

Hereafter the best measurement capability for CTL laboratory is reported:

Test	Range	Measurement Uncertainty	Notes
Radiated Emission	30~1000MHz	4.10dB	(1)
Radiated Emission	Above 1GHz	4.32dB	(1)
Conducted Disturbance	0.15~30MHz	3.20dB	(1)

- (1) This uncertainty represents an expanded uncertainty expressed at approximately the 95% confidence level using a coverage factor of $k=2$.

2. GENERAL INFORMATION

2.1. Environmental conditions

During the measurement the environmental conditions were within the listed ranges:

Normal Temperature:	25°C
Relative Humidity:	55 %
Air Pressure:	101 kPa

2.2. General Description of EUT

Product Name:	Car FM Transmitter
Model/Type reference:	C81
Power supply:	Input : DC 12V-24V Output: DC 5V/2.4A
FM	
Modulation:	FM
Operation frequency:	88.1-107.9MHz
Channel number:	199
Channel separation:	100KHz
Antenna type:	Spring antenna
Antenna gain:	0 dBi

Note: For more details, please refer to the user's manual of the EUT.

2.3. Description of Test Modes and Test Frequency

The Applicant provides communication tools software to control the EUT for staying in continuous transmitting (Duty Cycle more than 98%) and receiving mode for testing .

In section 15.31(m), regards to the operating frequency range over 10 MHz, the lowest frequency, the middle frequency, and the highest frequency of channel were selected to perform the test, and the selected channel see below:

Operation Frequency List :

Channel	Frequency (MHz)
01	88.1
02	88.2
⋮	⋮
100	98.0
101	98.1
102	98.2
⋮	⋮
198	107.8
199	107.9

Note: The line display in grey is the channel selected to perform test.

2.4. Equipments Used during the Test

Test Equipment	Manufacturer	Model No.	Serial No.	Calibration Date	Calibration Due Date
LISN	R&S	ESH2-Z5	860014/010	2021/05/10	2022/05/09
Bilog Antenna	Sunol Sciences Corp.	JB1	A061713	2020/04/08	2023/04/07
EMI Test Receiver	R&S	ESCI	1166.5950.03	2021/05/10	2022/05/09
Spectrum Analyzer	Agilent	E4407B	MY41440676	2021/05/19	2022/05/18
Spectrum Analyzer	Agilent	N9020A	US46220290	2021/05/19	2022/05/18
Spectrum Analyzer	Keysight	N9020A	MY53420874	2021/05/19	2022/05/18
Controller	EM Electronics	EM 1000	060859	2021/05/13	2022/05/12
Horn Antenna	Sunol Sciences Corp.	DRH-118	A062013	2021/05/13	2022/05/12
Active Loop Antenna	Da Ze	ZN30900A	/	2021/05/20	2022/05/19
Amplifier	Agilent	8449B	3008A02306	2021/05/13	2022/05/12
Amplifier	Agilent	8447D	2944A10176	2021/05/11	2022/05/10
Temperature/Humidity Meter	Gangxing	CTH-608	02	2021/05/16	2022/05/15
Power Sensor	Agilent	U2021XA	MY55130004	2021/05/19	2022/05/18
Power Sensor	Agilent	U2021XA	MY55130006	2021/05/19	2022/05/18
Spectrum Analyzer	RS	FSP	1164.4391.38	2021/05/15	2022/05/14
Test Software					
Name of Software			Version		
TST-PASS			1.0.5		
ES-K1(Below 1GHz)			V1.71		
e3(Above 1GHz)			6.111221a		

The calibration interval was one year

2.5. Related Submittal(s) / Grant(s)

This submittal(s) (test report) is intended to comply with Section 15.239 of the FCC Part 15, Subpart C Rules.

2.6. Modifications

No modifications were implemented to meet testing criteria.

3. TEST CONDITIONS AND RESULTS

3.1. Conducted Emissions Test

LIMIT

FCC CFR Title 47 Part 15 Subpart C Section 15.207

Frequency range (MHz)	Limit (dBuV)	
	Quasi-peak	Average
0.15-0.5	66 to 56*	56 to 46*
0.5-5	56	46
5-30	60	50

* Decreases with the logarithm of the frequency.

TEST CONFIGURATION

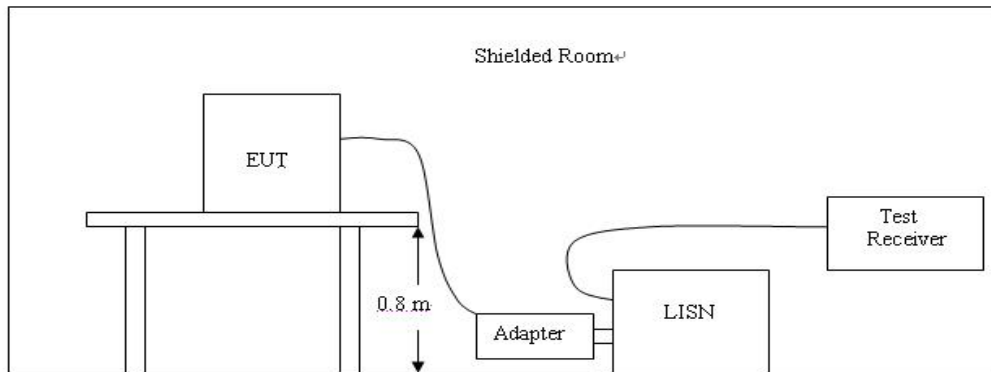

TEST PROCEDURE

1. The equipment was set up as per the test configuration to simulate typical actual usage per the user's manual. The EUT is a tabletop system; a wooden table with a height of 0.8 meters is used and is placed on the ground plane as per ANSI C63.10:2013.
2. Support equipment, if needed, was placed as per ANSI C63.10:2013.
3. All I/O cables were positioned to simulate typical actual usage as per ANSI C63.10:2013.
4. If a EUT received DC power from the USB Port of Notebook PC, the PC's adapter received AC120V/60Hz power through a Line Impedance Stabilization Network (LISN) which supplied power source and was grounded to the ground plane.
5. All support equipments received AC power from a second LISN, if any.
6. The EUT test program was started. Emissions were measured on each current carrying line of the EUT using a spectrum Analyzer / Receiver connected to the LISN powering the EUT. The LISN has two monitoring points: Line 1 (Hot Side) and Line 2 (Neutral Side). Two scans were taken: one with Line 1 connected to Analyzer / Receiver and Line 2 connected to a 50 ohm load; the second scan had Line 1 connected to a 50 ohm load and Line 2 connected to the Analyzer / Receiver.
7. Analyzer / Receiver scanned from 150 KHz to 30MHz for emissions in each of the test modes.
8. During the above scans, the emissions were maximized by cable manipulation.

TEST RESULTS

Not applicable to this device, for it is powered by car battery.

3.2. Radiated Emissions

Limit

15.239(b) The field strength of any emissions within the permitted 200 KHz band shall not exceed 250 microvolts/meter at 3 meters. The emission limit in this paragraph is based on measurement instrumentation employing an average detector. The provisions in §15.35 for limiting peak emissions apply.

Unless otherwise specified, the limit on peak radio frequency emissions is 20 dB above the maximum permitted average emission limit applicable to the equipment under test.

The field strength of any emissions radiated on any frequency outside of the specified 200 kHz band shall not exceed the general radiated emission limits in § 15.209 as table below:

Radiated emission limits

Frequency (MHz)	Distance (Meters)	Radiated (dB μ V/m)	Radiated (μ V/m)
0.009-0.49	3	$20\log(2400/F(\text{KHz}))+40\log(300/3)$	$2400/F(\text{KHz})$
0.49-1.705	3	$20\log(24000/F(\text{KHz}))+40\log(30/3)$	$24000/F(\text{KHz})$
1.705-30	3	$20\log(30)+40\log(30/3)$	30
30-88	3	40.0	100
88-216	3	43.5	150
216-960	3	46.0	200
Above 960	3	54.0	500

TEST CONFIGURATION

(A) Radiated Emission Test Set-Up, Frequency Below 30MHz

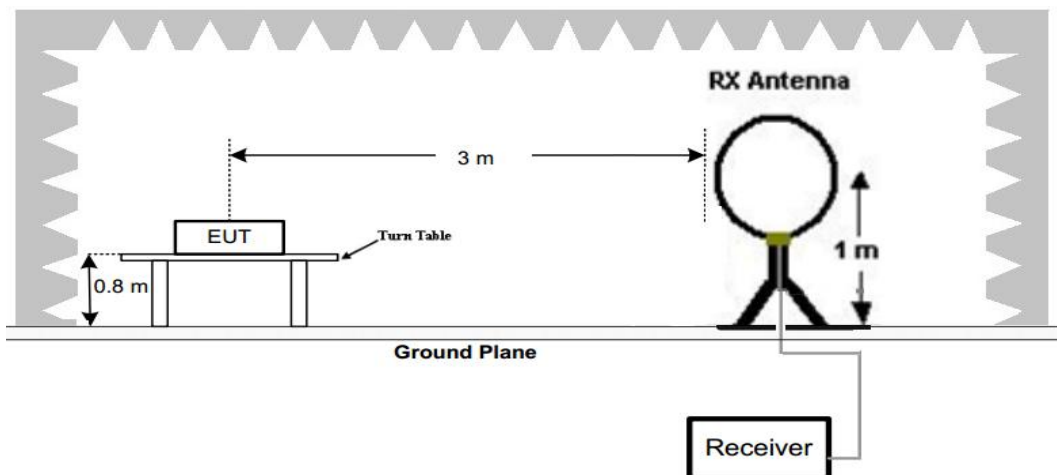

(B) Radiated Emission Test Set-Up, Frequency below 1000MHz

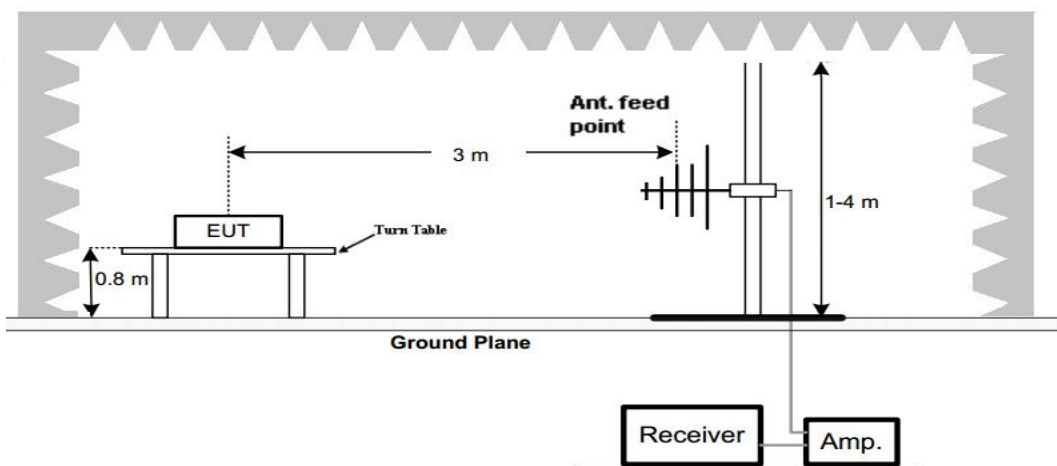

(C) Radiated Emission Test Set-Up, Frequency above 1000MHz

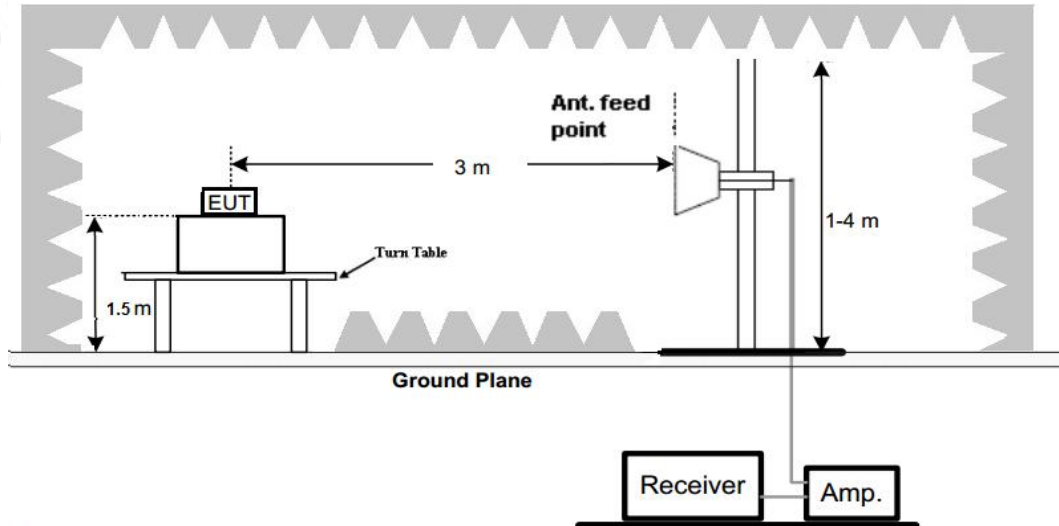
**Test Procedure**

1. Below 1GHz measurement the EUT is placed on a turntable which is 0.8m above ground plane, and above 1GHz measurement EUT was placed on a low permittivity and low loss tangent turn table which is 1.5m above ground plane.
2. Maximum procedure was performed by raising the receiving antenna from 1m to 4m and rotating the turn table from 0° to 360° to acquire the highest emissions from EUT
3. And also, each emission was to be maximized by changing the polarization of receiving antenna both horizontal and vertical.
4. Repeat above procedures until all frequency measurements have been completed.

TEST RESULTS

Remark: Radiated emission test from 9 KHz to 10th harmonic of fundamental was verified, and no emission found except system noise floor in 9KHz to 30MHz and not recorded in this report.

30MHz- 10th Harmonic of Fundamental

Frequency(MHz):				88.1		Polarity:			HORIZONTAL	
No.	Frequency (MHz)	Emission Level (dBuV/m)		Limit (dBuV/m)	Margin (dB)	Raw Value (dBuV)	Antenna Factor (dB/m)	Cable Factor (dB)	Pre-amplifier (dB)	Correction Factor (dB/m)
1	88.10	52.15	PK	68.00	15.85	71.68	8.72	0.56	28.81	-19.53
1	88.10	39.24	AV	48.00	8.76	58.77	8.72	0.56	28.81	-19.53
2	88.00	36.23	QP	40.00	3.77	55.79	8.70	0.55	28.81	-19.56
3	176.20	38.46	QP	43.50	5.04	54.12	11.95	1.05	28.66	-15.66
4	264.30	40.12	QP	46.00	5.88	54.52	12.86	1.48	28.74	-14.40
5	352.40	39.14	QP	46.00	6.86	51.19	14.32	1.95	28.32	-12.05
6	440.50	38.26	QP	46.00	7.74	48.47	16.57	2.18	28.96	-10.21
7	616.70	38.22	QP	46.00	7.78	46.53	18.32	2.24	28.87	-8.31
8	704.80	36.54	QP	46.00	9.46	41.95	20.19	3.09	28.69	-5.41

Frequency(MHz):				88.1		Polarity:			Vertical	
No.	Frequency (MHz)	Emission Level (dBuV/m)		Limit (dBuV/m)	Margin (dB)	Raw Value (dBuV)	Antenna Factor (dB/m)	Cable Factor (dB)	Pre-amplifier (dB)	Correction Factor (dB/m)
1	88.10	54.36	PK	68.00	13.64	73.89	8.72	0.56	28.81	-19.53
1	88.10	42.03	AV	48.00	5.97	61.56	8.72	0.56	28.81	-19.53
2	88.00	37.00	QP	40.00	3.00	56.56	8.70	0.55	28.81	-19.56
3	176.20	38.02	QP	43.50	5.48	53.68	11.95	1.05	28.66	-15.66
4	264.30	39.15	QP	46.00	6.85	53.55	12.86	1.48	28.74	-14.40
5	352.40	41.08	QP	46.00	4.92	53.13	14.32	1.95	28.32	-12.05
6	440.50	39.82	QP	46.00	6.18	50.03	16.57	2.18	28.96	-10.21
7	616.70	39.02	QP	46.00	6.98	47.33	18.32	2.24	28.87	-8.31
8	704.80	38.95	QP	46.00	7.05	44.36	20.19	3.09	28.69	-5.41

REMARKS:

1. Emission level (dBuV/m) = Raw Value (dBuV)+Correction Factor (dB/m)
2. Correction Factor (dB/m) =Antenna Factor (dB/m)+Cable Factor (dB)-Pre-amplifier Factor
3. Margin value = Limit value- Emission level
4. -- Mean the PK detector measured value is below QP limit
5. The other emission levels were very low against the limit
6. For fundamental frequency, RBW 100KHz VBW 300 Hz Peak detectors is for PK Value; RMS detector is for AV value

Frequency(MHz):				98.1		Polarity:			HORIZONTAL	
No.	Frequency (MHz)	Emission Level (dBuV/m)		Limit (dBuV/m)	Margin (dB)	Raw Value (dBuV)	Antenna Factor (dB/m)	Cable Factor (dB)	Pre-amplifier (dB)	Correction Factor (dB/m)
1	98.10	53.16	PK	68.00	14.84	72.66	8.78	0.57	28.85	-19.50
1	98.10	41.08	AV	48.00	6.92	60.58	8.78	0.57	28.85	-19.50
2	196.20	38.05	QP	43.50	5.45	53.84	11.98	1.11	28.88	-15.79
3	294.30	37.20	QP	46.00	8.8	51.46	13.11	1.54	28.91	-14.26
4	490.50	42.11	QP	46.00	3.89	54.38	14.58	2.20	29.05	-12.27
5	588.60	40.96	QP	46.00	5.04	52.19	15.64	2.23	29.10	-11.23
6	686.70	41.88	QP	46.00	4.12	50.06	18.69	2.28	29.15	-8.18
7	882.90	38.76	QP	46.00	7.24	43.53	21.59	3.26	29.62	-4.77

Frequency(MHz):				98.1		Polarity:			Vertical	
No.	Frequency (MHz)	Emission Level (dBuV/m)		Limit (dBuV/m)	Margin (dB)	Raw Value (dBuV)	Antenna Factor (dB/m)	Cable Factor (dB)	Pre-amplifier (dB)	Correction Factor (dB/m)
1	98.10	53.13	PK	68.00	14.87	72.63	8.78	0.57	28.85	-19.50
1	98.10	42.94	AV	48.00	5.06	62.44	8.78	0.57	28.85	-19.50
2	196.20	37.26	QP	43.50	6.24	53.05	11.98	1.11	28.88	-15.79
3	294.30	41.05	QP	46.00	4.95	55.31	13.11	1.54	28.91	-14.26
4	490.50	43.84	QP	46.00	2.16	56.11	14.58	2.20	29.05	-12.27
5	588.60	42.15	QP	46.00	3.85	53.38	15.64	2.23	29.10	-11.23
6	686.70	42.78	QP	46.00	3.22	50.96	18.69	2.28	29.15	-8.18
7	882.90	41.07	QP	46.00	4.93	45.84	21.59	3.26	29.62	-4.77

REMARKS:

1. Emission level (dBuV/m) = Raw Value (dBuV)+Correction Factor (dB/m)
2. Correction Factor (dB/m) =Antenna Factor (dB/m)+Cable Factor (dB)-Pre-amplifier Factor
3. Margin value = Limit value- Emission level
4. -- Mean the PK detector measured value is below QP limit
5. The other emission levels were very low against the limit
6. For fundamental frequency, RBW 100KHz VBW 300 Hz Peak detectors is for PK Value; RMS detector is for AV value

Frequency(MHz):				107.9		Polarity:			HORIZONTAL	
No.	Frequency (MHz)	Emission Level (dBuV/m)		Limit (dBuV/m)	Margin (dB)	Raw Value (dBuV)	Antenna Factor (dB/m)	Cable Factor (dB)	Pre-amplifier (dB)	Correction Factor (dB/m)
1	107.90	56.15	PK	68.00	11.85	75.44	9.04	0.65	28.98	-19.29
1	107.90	43.26	AV	48.00	4.74	62.55	9.04	0.65	28.98	-19.29
2	108.00	39.98	QP	43.50	3.52	59.26	9.05	0.65	28.98	-19.28
3	215.80	38.72	QP	43.50	4.78	54.13	12.14	1.35	28.90	-15.41
4	323.70	41.05	QP	46.00	4.95	54.74	13.58	1.68	28.95	-13.69
5	431.60	42.08	QP	46.00	3.92	54.81	14.25	2.04	29.02	-12.73
6	539.50	42.15	QP	46.00	3.85	53.63	15.47	2.13	29.08	-11.48
7	755.30	40.67	QP	46.00	5.33	48.39	19.11	2.39	29.22	-7.72
8	863.20	39.15	QP	46.00	6.85	44.15	21.34	3.17	29.51	-5.00

Frequency(MHz):				107.9		Polarity:			Vertical	
No.	Frequency (MHz)	Emission Level (dBuV/m)		Limit (dBuV/m)	Margin (dB)	Raw Value (dBuV)	Antenna Factor (dB/m)	Cable Factor (dB)	Pre-amplifier (dB)	Correction Factor (dB/m)
1	107.90	55.38	PK	68.00	12.62	74.67	9.04	0.65	28.98	-19.29
1	107.90	43.67	AV	48.00	4.33	62.96	9.04	0.65	28.98	-19.29
2	108.00	38.16	QP	43.50	5.34	57.44	9.05	0.65	28.98	-19.28
3	215.80	37.36	QP	43.50	6.14	52.77	12.14	1.35	28.90	-15.41
4	323.70	41.65	QP	46.00	4.35	55.34	13.58	1.68	28.95	-13.69
5	431.60	42.84	QP	46.00	3.16	55.57	14.25	2.04	29.02	-12.73
6	539.50	42.02	QP	46.00	3.98	53.50	15.47	2.13	29.08	-11.48
7	755.30	40.00	QP	46.00	6.00	47.72	19.11	2.39	29.22	-7.72
8	863.20	41.74	QP	46.00	4.26	46.74	21.34	3.17	29.51	-5.00

REMARKS:

1. Emission level (dBuV/m) = Raw Value (dBuV)+Correction Factor (dB/m)
2. Correction Factor (dB/m) =Antenna Factor (dB/m)+Cable Factor (dB)-Pre-amplifier Factor
3. Margin value = Limit value- Emission level
4. -- Mean the PK detector measured value is below QP limit
5. The other emission levels were very low against the limit
6. For fundamental frequency, RBW 100KHz VBW 300 Hz Peak detectors is for PK Value; RMS detector is for AV value

3.3. Occupied Bandwidth

Limit

Emissions from the intentional radiator shall be confined within a band 200 kHz wide centered on the operating frequency. The 200 kHz band shall lie wholly within the frequency range of 88–108 MHz.

Test Configuration



Test Procedure

The transmitter output was connected to the spectrum analyzer through an attenuator. The bandwidth of the fundamental frequency was measured by spectrum analyzer with 30 KHz RBW and 100 KHz VBW.

The 20dB bandwidth is defined as the total spectrum the power of which is higher than peak power minus 20dB.

Test Results

Modulation	Channel	99% OBW (KHz)	20dB bandwidth (KHz)	Limit (KHz)	Result
FM	CH01	17.817	17.22	200	Pass
	CH101	17.207	16.45	200	
	CH199	17.712	15.23	200	

Test plot as follows:

FM Modulation

CH01

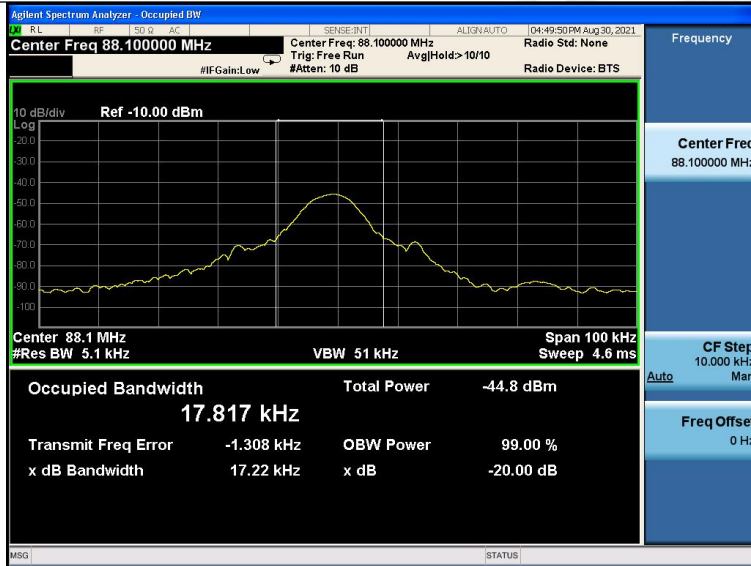

CH101

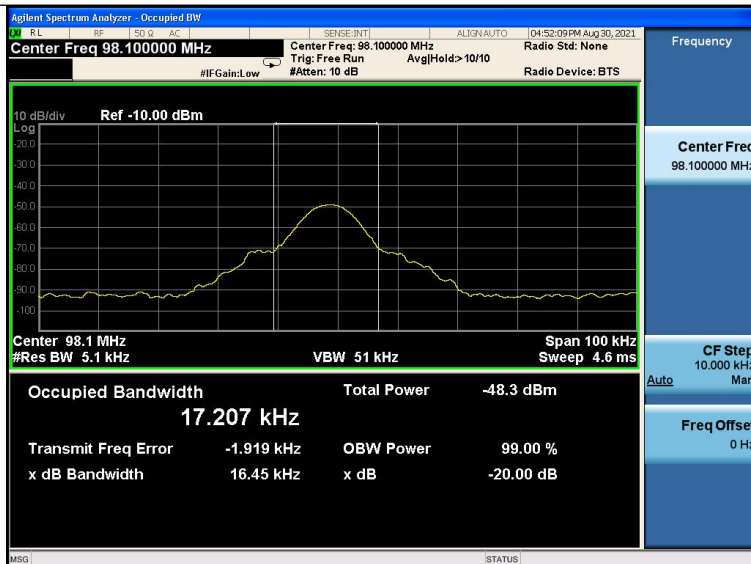

CH199

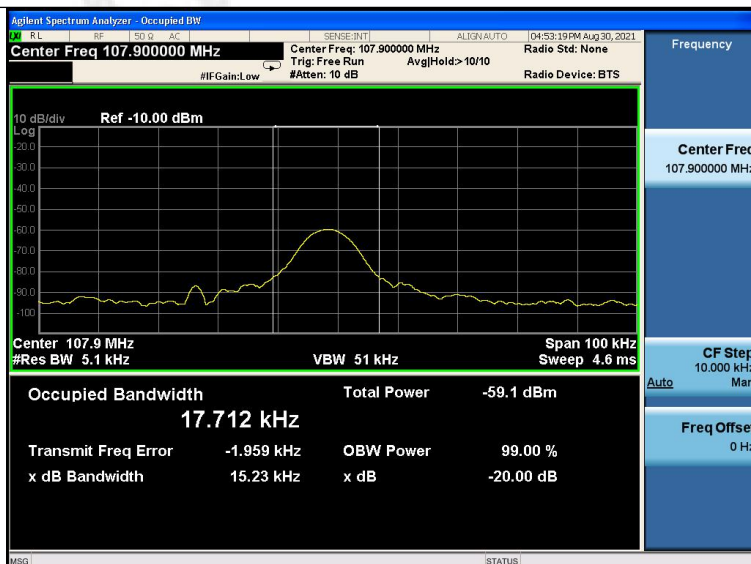

3.4. Antenna Requirement

Standard Applicable

For intentional device, according to FCC 47 CFR Section 15.203, an intentional radiator shall be designed to ensure that no antenna other than that furnished by the responsible party shall be used with the device.

Refer to statement below for compliance.

The manufacturer may design the unit so that the user can replace a broken antenna, but the use of a standard antenna jack or electrical connector is prohibited. Further, this requirement does not apply to intentional radiators that must be professionally installed.

Antenna Connected Construction

The antenna used in this product is an internal Antenna, The directional gains of antenna used for transmitting is 0 dBi.

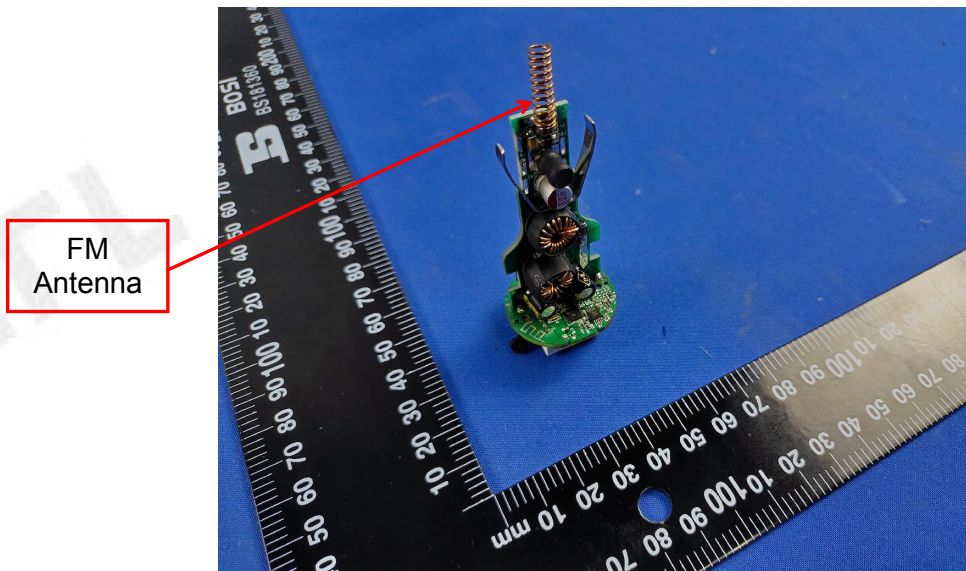

4. Test Setup Photos of the EUT

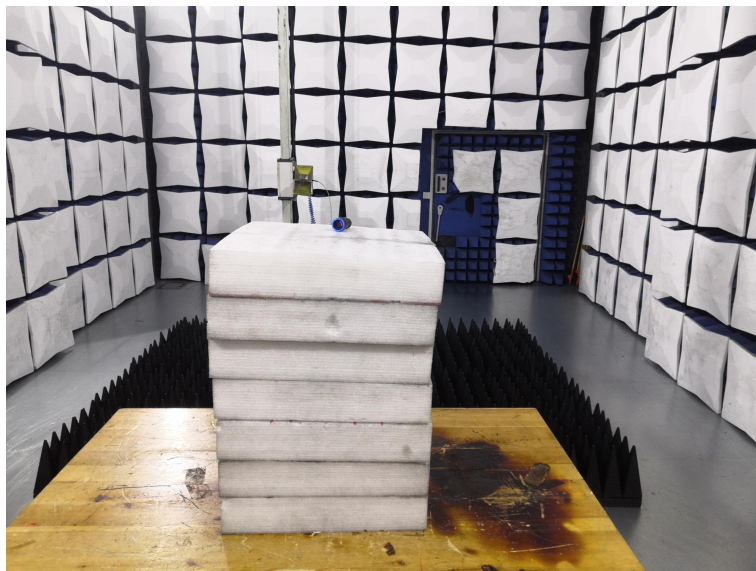
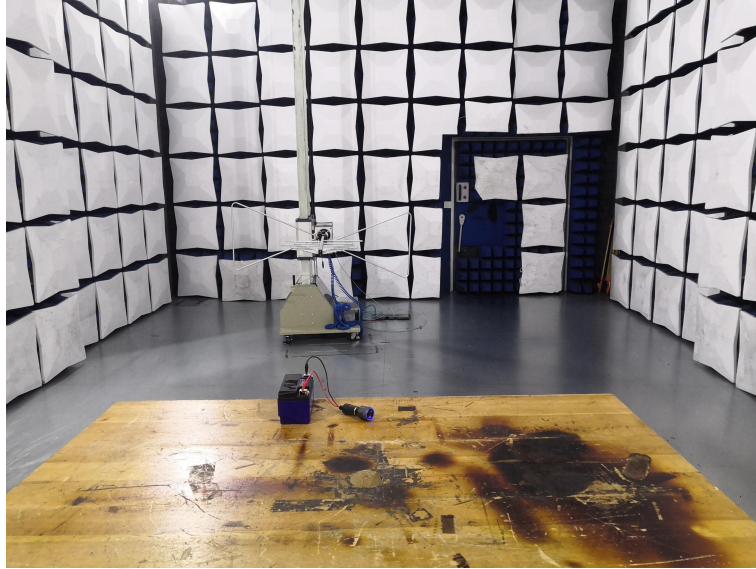

5. External and Internal Photos of the EUT

External Photos of EUT





Internal Photos of EUT

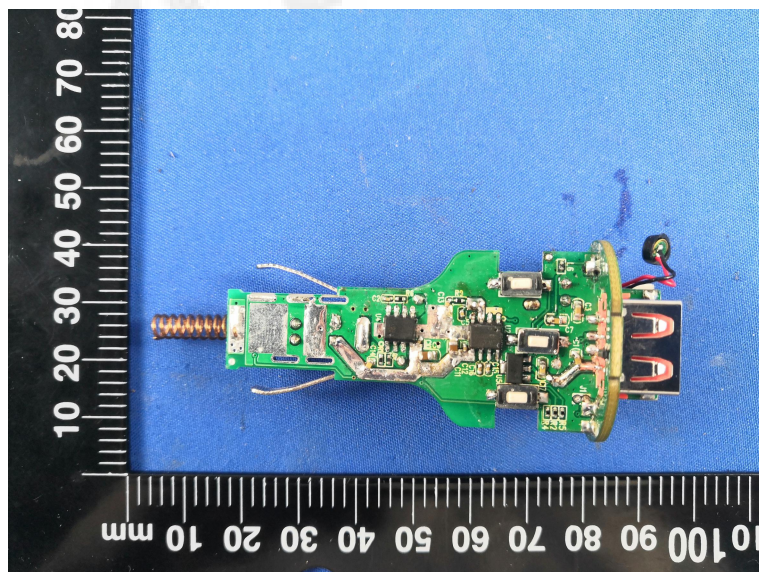
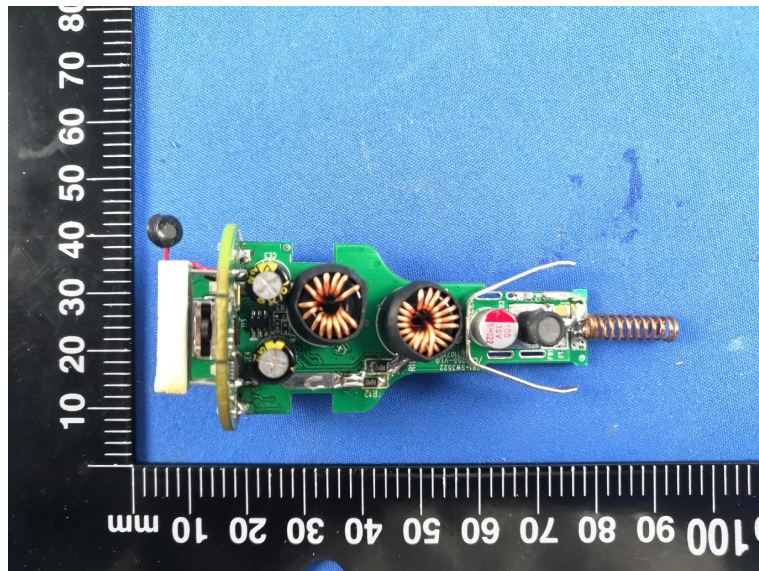
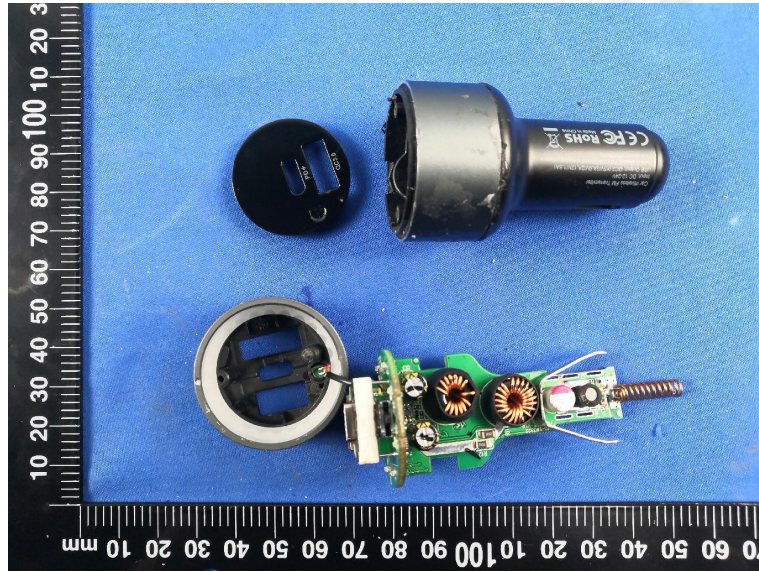

FM Antenna

BT Antenna

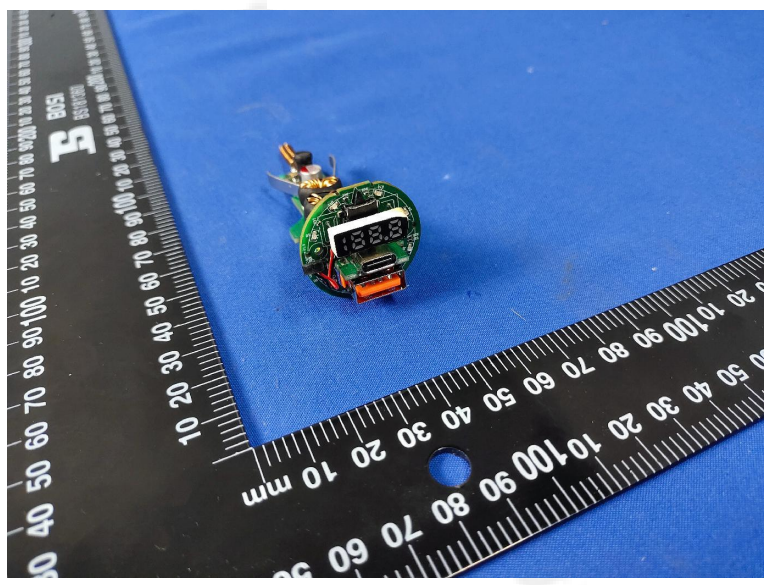
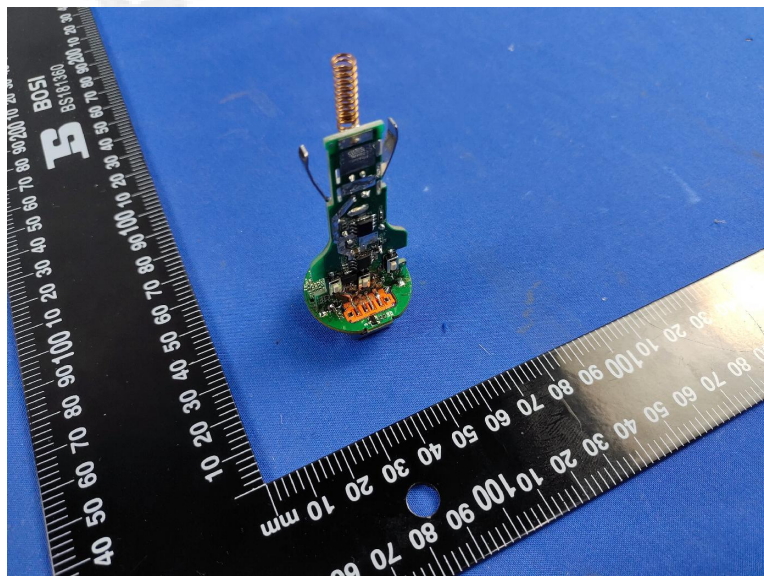
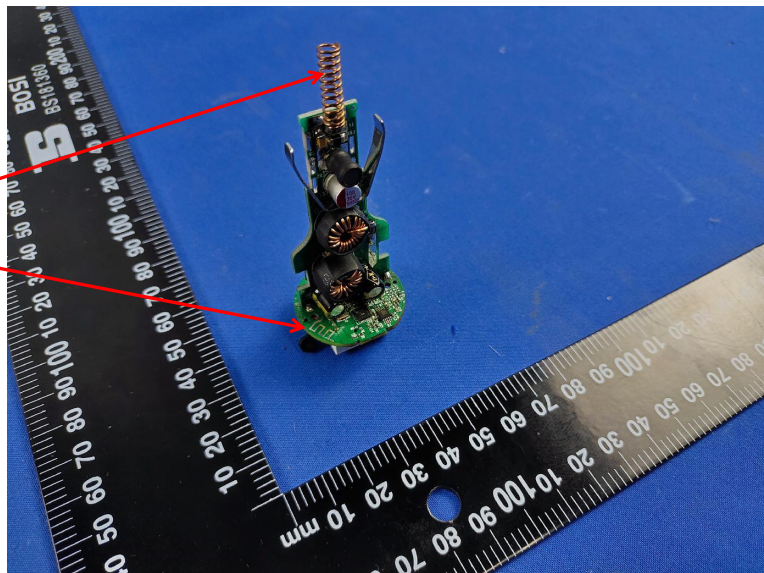

***** End of Report *****