



TEST REPORT

Test report no.: 1-8237/19-02-02-A



Testing laboratory

CTC advanced GmbH

Untertuerkheimer Strasse 6 – 10
66117 Saarbruecken / Germany
Phone: + 49 681 5 98 - 0
Fax: + 49 681 5 98 - 9075
Internet: <http://www.ctcadvanced.com>
e-mail: mail@ctcadvanced.com

Accredited Testing Laboratory:

The testing laboratory (area of testing) is accredited according to DIN EN ISO/IEC 17025 (2005) by the Deutsche Akkreditierungsstelle GmbH (DAkkS). The accreditation is valid for the scope of testing procedures as stated in the accreditation certificate with the registration number: D-PL-12076-01-04 & 05

Applicant

EUCHNER GmbH + Co. KG

Kohlhammerstraße 16
70771 Leinfelden-Echterdingen / GERMANY
Phone: +49 711 7597-0
Contact: Holger Kissing
e-mail: holger.kissing@euchner.de
Phone: +49 711 7597-336

Manufacturer

EUCHNER GmbH + Co. KG

Kohlhammerstraße 16
70771 Leinfelden-Echterdingen / GERMANY

Test standard/s

FCC - Title 47 CFR Part 15

FCC - Title 47 of the Code of Federal Regulations; Chapter I; Part 15 - Radio frequency devices

RSS - 210 Issue 9

Spectrum Management and Telecommunications Radio Standards Specification - Licence-Exempt Radio Apparatus: Category I Equipment

For further applied test standards please refer to section 3 of this test report.

Test Item

Kind of test item: Safety switch
Model name: CTP
FCC ID: 2AJ58-05
IC: 22052-05
Frequency: 125 kHz
Technology tested: RFID
Antenna: Integrated antenna
Power supply: 20.0 V to 28.0 V DC by external power supply
Temperature range: 0°C to +55°C

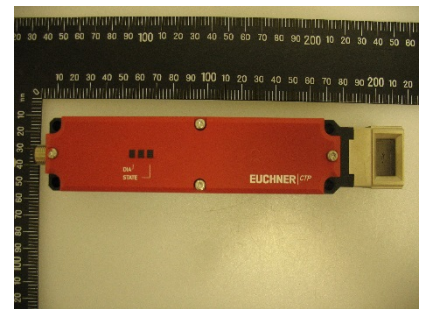

This test report is electronically signed and valid without handwritten signature. For verification of the electronic signatures, the public keys can be requested at the testing laboratory.

Test report authorized:

Christoph Schneider
Lab Manager
Radio Communications & EMC

Test performed:

Tobias Wittenmeier
Testing Manager
Radio Communications & EMC

1 Table of contents

1	Table of contents	2
2	General information	3
2.1	Notes and disclaimer	3
2.2	Application details.....	3
2.3	Test laboratories sub-contracted	3
3	Test standard/s and references	4
4	Test environment.....	5
5	Test item.....	5
5.1	General description.....	5
5.2	Additional information	6
6	Description of the test setup.....	7
6.1	Shielded semi anechoic chamber.....	8
6.2	Shielded fully anechoic chamber	9
6.3	AC conducted	10
6.4	Test setup for normalized measurement configurations	11
7	Sequence of testing	12
7.1	Sequence of testing radiated spurious 9 kHz to 30 MHz.....	12
7.2	Sequence of testing radiated spurious 30 MHz to 1 GHz.....	13
8	Measurement uncertainty	14
9	Summary of measurement results	15
10	Additional comments	15
11	Measurement results	16
11.1	Occupied bandwidth.....	16
11.2	Field strength of the fundamental	18
11.3	Field strength of the harmonics and spurious	20
11.4	Conducted limits	25
12	Observations	30
Annex A	Glossary.....	31
Annex B	Document history	32
Annex C	Accreditation Certificate – D-PL-12076-01-04	32
Annex D	Accreditation Certificate – D-PL-12076-01-05	33

2 General information

2.1 Notes and disclaimer

The test results of this test report relate exclusively to the test item specified in this test report. CTC advanced GmbH does not assume responsibility for any conclusions and generalizations drawn from the test results with regard to other specimens or samples of the type of the equipment represented by the test item.

The test report may only be reproduced or published in full. Reproduction or publication of extracts from the report requires the prior written approval of CTC advanced GmbH.

The testing service provided by CTC advanced GmbH has been rendered under the current "General Terms and Conditions for CTC advanced GmbH".

CTC advanced GmbH will not be liable for any loss or damage resulting from false, inaccurate, inappropriate or incomplete product information provided by the customer.

Under no circumstances does the CTC advanced GmbH test report include any endorsement or warranty regarding the functionality, quality or performance of any other product or service provided.

Under no circumstances does the CTC advanced GmbH test report include or imply any product or service warranties from CTC advanced GmbH, including, without limitation, any implied warranties of merchantability, fitness for purpose, or non-infringement, all of which are expressly disclaimed by CTC advanced GmbH.

All rights and remedies regarding vendor's products and services for which CTC advanced GmbH has prepared this test report shall be provided by the party offering such products or services and not by CTC advanced GmbH. In no case this test report can be considered as a Letter of Approval.

This test report is electronically signed and valid without handwritten signature. For verification of the electronic signatures, the public keys can be requested at the testing laboratory.

This test report replaces the test report with the number 1-8237/19-02-02 and dated 2019-06-03.

2.2 Application details

Date of receipt of order:	2019-04-12
Date of receipt of test item:	2019-04-25
Start of test:	2019-04-25
End of test:	2019-04-26
Person(s) present during the test:	-/-

2.3 Test laboratories sub-contracted

None

3 Test standard/s and references

Test standard	Date	Description
FCC - Title 47 CFR Part 15	-/-	FCC - Title 47 of the Code of Federal Regulations; Chapter I; Part 15 - Radio frequency devices
RSS - 210 Issue 9	August 2016	Spectrum Management and Telecommunications Radio Standards Specification - Licence-Exempt Radio Apparatus: Category I Equipment
RSS - Gen Issue 5	April 2018	Spectrum Management and Telecommunications Radio Standards Specification - General Requirements for Compliance of Radio Apparatus

Guidance	Version	Description
ANSI C63.4-2014	-/-	American National Standard for Methods of Measurement of Radio-Noise Emissions from Low-Voltage Electrical and Electronic Equipment in the Range of 9 kHz to 40 GHz
ANSI C63.10-2013	-/-	American National Standard of Procedures for Compliance Testing of Unlicensed Wireless Devices

4 Test environment

Temperature	:	T_{nom} T_{max} T_{min}	+22 °C during room temperature tests +55 °C during high temperature tests* 0 °C during low temperature tests*
Relative humidity content	:		55 %
Barometric pressure	:		1021 hpa
Power supply	:	V_{nom} V_{max} V_{min}	24.0 V DC by external power supply 28.0 V* 20.0 V*

*No tests under extreme conditions required.

5 Test item

5.1 General description

Kind of test item	:	Safety switch
Type identification	:	CTP
FCC ID	:	2AJ58-05
IC ID	:	22052-05
HMN	:	-/-
PMN	:	CTP-I-AR SERIES CTP-I1-AR SERIES CTP-I2-AR SERIES CTP-L1-AR SERIES CTP-L2-AR SERIES CTP-I-AP SERIES CTP-I1-AP SERIES CTP-I2-AP SERIES CTP-L1-AP SERIES CTP-L2-AP SERIES CTP-IBI-AR SERIES CTP-LBI-AR SERIES CTP-IBI-AP SERIES CTP-LBI-AP SERIES
HVIN	:	05
FVIN	:	-/-
S/N serial numbers	:	CTP-I-AP-U-HA-ZZ-SA-136732 (CTP-I-AP SERIES) : 007469 CTP-L2-AR-U-HA-AZ-SAB- 122814 (CTP-L2-AR SERIES): 004983
Hardware status	:	V1.0.0
Software status	:	V 4.02
Firmware status	:	V4.02
Frequency	:	125 kHz
Type of radio transmission	:	Modulated carrier
Use of frequency spectrum	:	
Type of modulation	:	AM
Number of channels	:	1
Antenna	:	Integrated antenna
Power supply	:	20.0 V to 28.0 V DC by external power supply
Temperature range	:	0°C to +55°C

6 Description of the test setup

Typically, the calibrations of the test apparatus are commissioned to and performed by an accredited calibration laboratory. The calibration intervals are determined in accordance with the DIN EN ISO/IEC 17025. In addition to the external calibrations, the laboratory executes comparison measurements with other calibrated test systems or effective verifications. Weekly chamber inspections and range calibrations are performed. Where possible, RF generating and signaling equipment as well as measuring receivers and analyzers are connected to an external high-precision 10 MHz reference (GPS-based or rubidium frequency standard).

In order to simplify the identification of the equipment used at some special tests, some items of test equipment and ancillaries can be provided with an identifier or number in the equipment list below (Lab/Item).

Agenda: Kind of Calibration

k	calibration / calibrated	EK	limited calibration
ne	not required (k, ev, izw, zw not required)	zw	cyclical maintenance (external cyclical maintenance)
ev	periodic self verification	izw	internal cyclical maintenance
Ve	long-term stability recognized	g	blocked for accredited testing
v/k!	Attention: extended calibration interval		
NK!	Attention: not calibrated	*)	next calibration ordered / currently in progress

6.1 Shielded semi anechoic chamber

The radiated measurements are performed in vertical and horizontal plane in the frequency range from 30 MHz to 1 GHz in semi-anechoic chambers. The EUT is positioned on a non-conductive support with a height of 0.80 m above a conductive ground plane that covers the whole chamber. The receiving antennas are conform to specifications ANSI C63. These antennas can be moved over the height range between 1.0 m and 4.0 m in order to search for maximum field strength emitted from EUT. The measurement distances between EUT and receiving antennas are indicated in the test setups for the various frequency ranges. For each measurement, the EUT is rotated in all three axes until the maximum field strength is received. The wanted and unwanted emissions are received by spectrum analyzers where the detector modes and resolution bandwidths over various frequency ranges are set according to requirement ANSI C63.

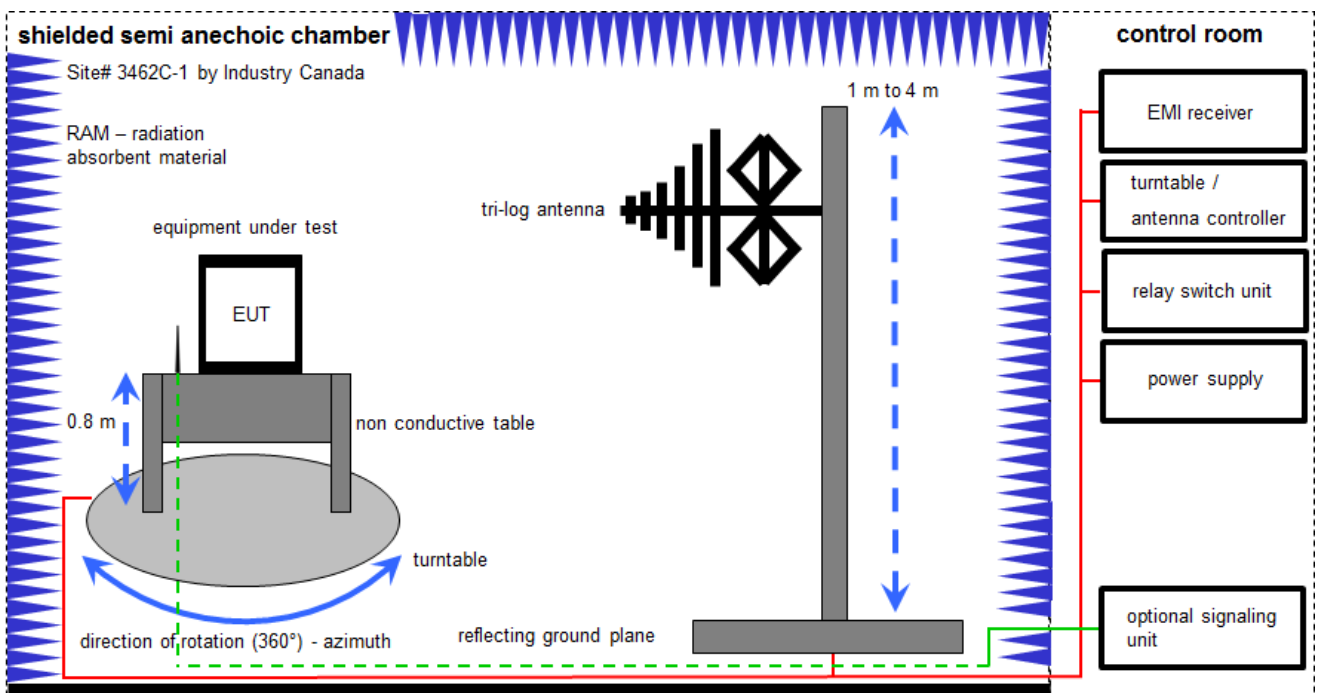

Measurement distance: tri-log antenna 10 meter

EMC32 software version: 10.30.0

FS = UR + CL + AF

(FS-field strength; UR-voltage at the receiver; CL-loss of the cable; AF-antenna factor)

Example calculation:

FS [dBµV/m] = 12.35 [dBµV/m] + 1.90 [dB] + 16.80 [dB/m] = 31.05 [dBµV/m] (35.69 µV/m)

Equipment table:

No.	Lab / Item	Equipment	Type	Manufacturer	Serial No.	INV. No.	Kind of Calibration	Last Calibration	Next Calibration
1	A	Switch-Unit	3488A	HP	2719A14505	300000368	ev	-/-	-/-
2	A	Meßkabine 1	HF-Absorberhalle	MWB AG 300023		300000551	ne	-/-	-/-
3	A	EMI Test Receiver	ESCI 3	R&S	100083	300003312	k	12.12.2018	11.12.2019
5	A	Antenna Tower	Model 2175	ETS-Lindgren	64762	300003745	izw	-/-	-/-
6	A	Positioning Controller	Model 2090	ETS-Lindgren	64672	300003746	izw	-/-	-/-
7	A	Turntable Interface-Box	Model 105637	ETS-Lindgren	44583	300003747	izw	-/-	-/-
8	A	TRILOG Broadband Test-Antenna 30 MHz - 3 GHz	VULB9163	Schwarzbeck Mess - Elektronik	371	300003854	vKI!	24.11.2017	23.11.2020

6.2 Shielded fully anechoic chamber

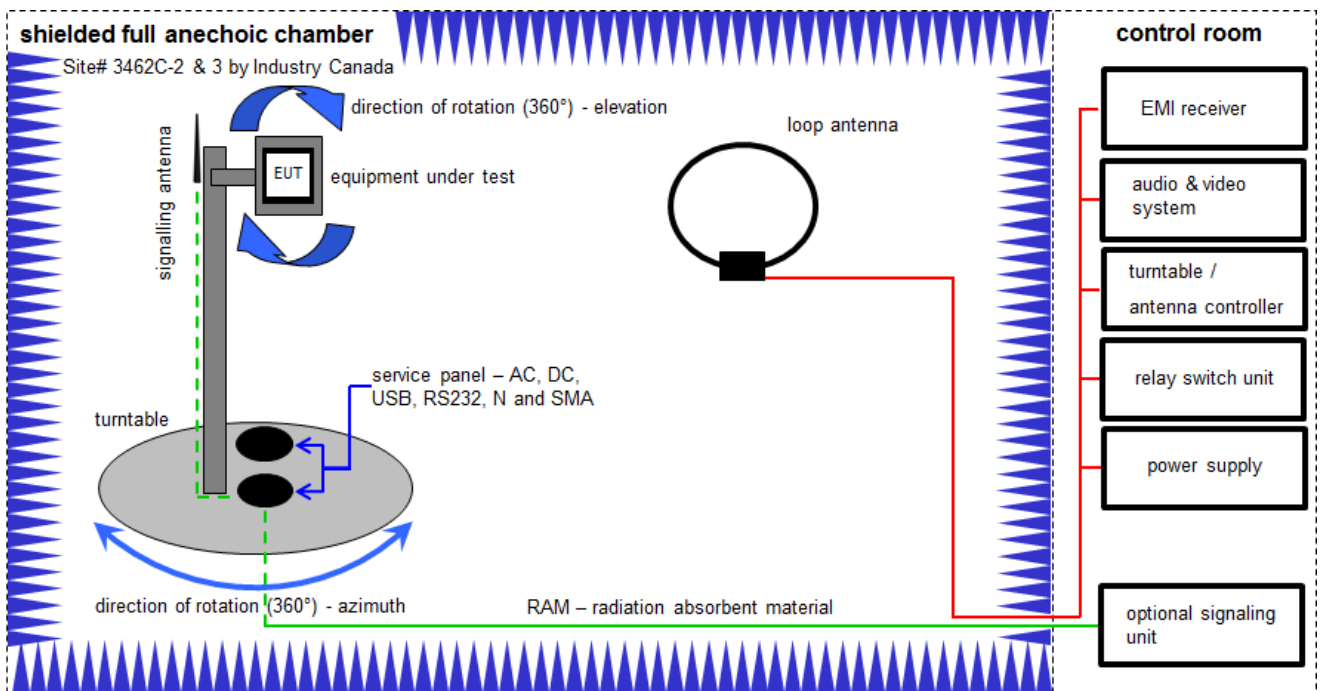

Measurement distance: loop antenna 3 meter

$$FS = UR + CA + AF$$

(FS-field strength; UR-voltage at the receiver; CA-loss of the signal path; AF-antenna factor)

Example calculation:

$$FS [dB\mu V/m] = 40.0 [dB\mu V/m] + (-35.8) [dB] + 32.9 [dB/m] = 37.1 [dB\mu V/m] (71.61 \mu V/m)$$

Equipment table:

No.	Lab / Item	Equipment	Type	Manufacturer	Serial No.	INV. No.	Kind of Calibration	Last Calibration	Next Calibration
1	A	Active Loop Antenna 9 kHz to 30 MHz	6502	EMCO	2210	300001015	vKI!	07.07.2017	06.07.2019
2	A	4U RF Switch Platform	L4491A	Agilent Technologies	MY50000032	300004510	ne	-/-	-/-
3	A	Computer	Intel Core i3 3220/3,3 GHz, Prozessor	-/-	2V2403033A54 21	300004591	ne	-/-	-/-
4	A	NEXIO EMV- Software	BAT EMC V3.16.0.49	EMCO	-/-	300004682	ne	-/-	-/-
5	A	Anechoic chamber	-/-	TDK	-/-	300003726	ne	-/-	-/-
6	A	EMI Test Receiver 9kHz-26,5GHz	ESR26	R&S	101376	300005063	k	19.12.2018	18.12.2019

6.3 AC conducted

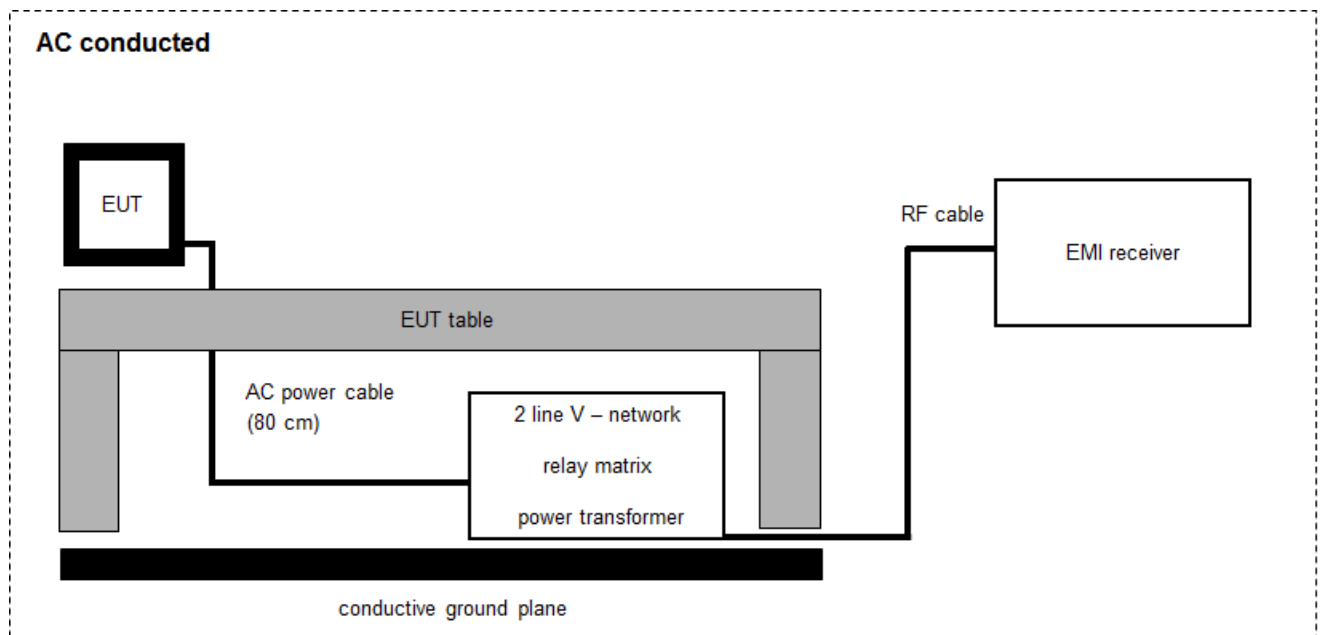

$$FS = UR + CF + VC$$

(FS-field strength; UR-voltage at the receiver; CR-loss of the cable and filter; VC-correction factor of the ISN)

Example calculation:

$$FS [dB\mu V/m] = 37.62 [dB\mu V/m] + 9.90 [dB] + 0.23 [dB] = 47.75 [dB\mu V/m] \quad (244.06 \mu V/m)$$

Equipment table:

No.	Lab / Item	Equipment	Type	Manufacturer	Serial No.	INV. No.	Kind of Calibration	Last Calibration	Next Calibration
1	A	Two-line V-Network (LISN) 9 kHz to 30 MHz	ESH3-Z5	R&S	892475/017	300002209	vIKI!	13.12.2017	12.12.2019
2	A	RF-Filter-section	85420E	HP	3427A00162	300002214	NK!	-/-	-/-
3	A	Hochpass 150 kHz	EZ-25	R&S	100010	300003798	ev	-/-	-/-
4	A	MXE EMI Receiver 20 Hz to 26,5 GHz	N9038A	Agilent Technologies	MY51210197	300004405	k	12.12.2018	11.12.2019

6.4 Test setup for normalized measurement configurations

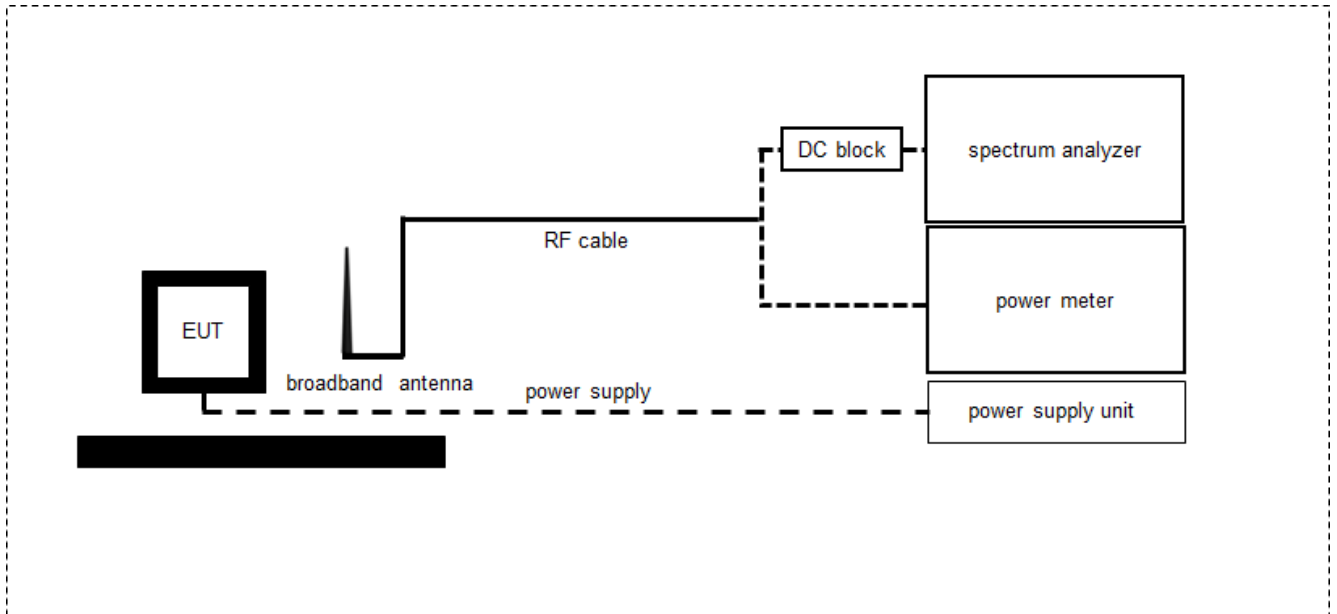

$$FS = UR + CA + AF$$

(FS-field strength; UR-voltage at the receiver; CA-loss of the signal path; AF-antenna factor)

Example calculation:

$$FS [dB\mu V/m] = 40.0 [dB\mu V/m] + (-35.8) [dB] + 32.9 [dB/m] = 37.1 [dB\mu V/m] (71.61 \mu V/m)$$

Equipment table:

No.	Lab / Item	Equipment	Type	Manufacturer	Serial No.	INV. No.	Kind of Calibration	Last Calibration	Next Calibration
1	A	EMI Test Receiver 9 kHz - 3 GHz incl. Preselector	ESPI3	R&S	101713	300004059	k	13.12.2018	12.12.2019
2	A	Loop Antenna	-/-	ZEG TS Steinfurt	-/-	400001208	ev	-/-	-/-
3	A	RF Cable BNC	RG58	Huber & Suhner	-/-	400001209	ev	-/-	-/-

7 Sequence of testing

7.1 Sequence of testing radiated spurious 9 kHz to 30 MHz

Setup

- The equipment is set up to simulate normal operation mode as described in the user manual or defined by the manufacturer.
- If the EUT is a tabletop system, it is placed on a table with 0.8 m height.
- If the EUT is a floor standing device, it is placed directly on the turn table.
- Auxiliary equipment and cables are positioned to simulate normal operation conditions as described in ANSI C 63.4.
- The AC power port of the EUT (if available) is connected to a power outlet below the turntable.
- Measurement distance is 3 m (see ANSI C 63.4) – see test details.
- EUT is set into operation.

Premeasurement*

- The turntable rotates from 0° to 315° using 45° steps.
- The antenna height is 1 m.
- At each turntable position the analyzer sweeps with positive-peak detector to find the maximum of all emissions.

Final measurement

- Identified emissions during the pre-measurement are maximized by the software by rotating the turntable from 0° to 360°.
- Loop antenna is rotated about its vertical axis for maximum response at each azimuth about the EUT. (For certain applications, the loop antenna plane may also need to be positioned horizontally at the specified distance from the EUT)
- The final measurement is done in the position (turntable and elevation) causing the highest emissions with quasi-peak (as described in ANSI C 63.4).
- Final levels, frequency, measuring time, bandwidth, turntable position, correction factor, margin to the limit and limit will be recorded. A plot with the graph of the premeasurement and the limit is stored.

*)Note: The sequence will be repeated three times with different EUT orientations.

7.2 Sequence of testing radiated spurious 30 MHz to 1 GHz

Setup

- The equipment is set up to simulate normal operation mode as described in the user manual or defined by the manufacturer.
- If the EUT is a tabletop system, a table with 0.8 m height is used, which is placed on the ground plane.
- If the EUT is a floor standing device, it is placed on the ground plane with insulation between both.
- Auxiliary equipment and cables are positioned to simulate normal operation conditions as described in ANSI C 63.4.
- The AC power port of the EUT (if available) is connected to a power outlet below the turntable.
- Measurement distance is 10 m or 3 m (see ANSI C 63.4) – see test details.
- EUT is set into operation.

Premeasurement

- The turntable rotates from 0° to 315° using 45° steps.
- The antenna is polarized vertical and horizontal.
- The antenna height changes from 1 m to 3 m.
- At each turntable position, antenna polarization and height the analyzer sweeps three times in peak to find the maximum of all emissions.

Final measurement

- The final measurement is performed for at least six highest peaks according to the requirements of the ANSI C63.4.
- Based on antenna and turntable positions at which the peak values are measured the software maximize the peaks by changing turntable position $\pm 45^\circ$ and antenna height between 1 and 4 m.
- The final measurement is done with quasi-peak detector (as described in ANSI C 63.4).
- Final levels, frequency, measuring time, bandwidth, antenna height, antenna polarization, turntable angle, correction factor, margin to the limit and limit are recorded. A plot with the graph of the premeasurement with marked maximum final results and the limit is stored.

8 Measurement uncertainty

Measurement uncertainty	
Test case	Uncertainty
Occupied bandwidth	± used RBW
Field strength of the fundamental	± 3 dB
Field strength of the harmonics and spurious	± 3 dB
Receiver spurious emissions and cabinet radiations	± 3 dB
Conducted limits	± 2.6 dB

9 Summary of measurement results

<input checked="" type="checkbox"/>	No deviations from the technical specifications were ascertained
<input type="checkbox"/>	There were deviations from the technical specifications ascertained
<input type="checkbox"/>	This test report is only a partial test report. The content and verdict of the performed test cases are listed below.

TC Identifier	Description	Verdict	Date	Remark
RF-Testing	CFR Part 15 RSS 210 Issue 9 RSS Gen Issue 5	See table!	2019-06-11	-/-

Test specification clause	Test case	Temperature conditions	Power source conditions	C	NC	NA	NP	Remark
RSS Gen Issue 5 (6.6)	Occupied bandwidth	Nominal	Nominal	<input checked="" type="checkbox"/>	<input type="checkbox"/>	<input type="checkbox"/>	<input type="checkbox"/>	-/-
§ 15.209	Field strength of the fundamental	Nominal	Nominal	<input checked="" type="checkbox"/>	<input type="checkbox"/>	<input type="checkbox"/>	<input type="checkbox"/>	-/-
§ 15.209 RSS Gen Issue 5 (6.13)	Field strength of the harmonics and spurious	Nominal	Nominal	<input checked="" type="checkbox"/>	<input type="checkbox"/>	<input type="checkbox"/>	<input type="checkbox"/>	-/-
§ 15.109	Receiver spurious emissions and cabinet radiations	Nominal	Nominal	<input type="checkbox"/>	<input type="checkbox"/>	<input checked="" type="checkbox"/>	<input type="checkbox"/>	-/-
§15.107 §15.207	Conducted limits	Nominal	Nominal	<input checked="" type="checkbox"/>	<input type="checkbox"/>	<input type="checkbox"/>	<input type="checkbox"/>	-/-

Note: NA = Not applicable; NP = Not performed; C = Compliant; NC = Not compliant

10 Additional comments

Reference documents: None

Special test descriptions: We tested 2 different model variants:

EUT A: CTP-I-AP-U-HA-ZZ-SA-136732 (CTP-I-AP SERIES)

EUT B: CTP-L2-AR-U-HA-AZ-SAB- 122814 (CTP-L2-AR SERIES)

EUT short description is used to simplify the identification of the EUTs in this test report.

Configuration descriptions: None

11 Measurement results

11.1 Occupied bandwidth

Measurement:

The emission bandwidth (x dB) is defined as the frequency range between two points, one above and one below the carrier frequency, at which the spectral density of the emission is attenuated x dB below the maximum in-band spectral density of the modulated signal.

Measurement parameters	
Detector:	Peak
Resolution bandwidth:	1 % – 5 % of the occupied bandwidth
Video bandwidth:	≥ 3x RBW
Trace mode:	Max hold
Analyser function:	99 % power function
Used test setup:	See sub clause 6.4 - A
Measurement uncertainty:	See sub clause 8

Limit:

IC
for RSP-100 test report coversheet only

Result:

EUT A

99% emission bandwidth
10.80 kHz

EUT B

99% emission bandwidth
11.44 kHz

Plot:

Plot 1: 99 % emission bandwidth (EUT A)

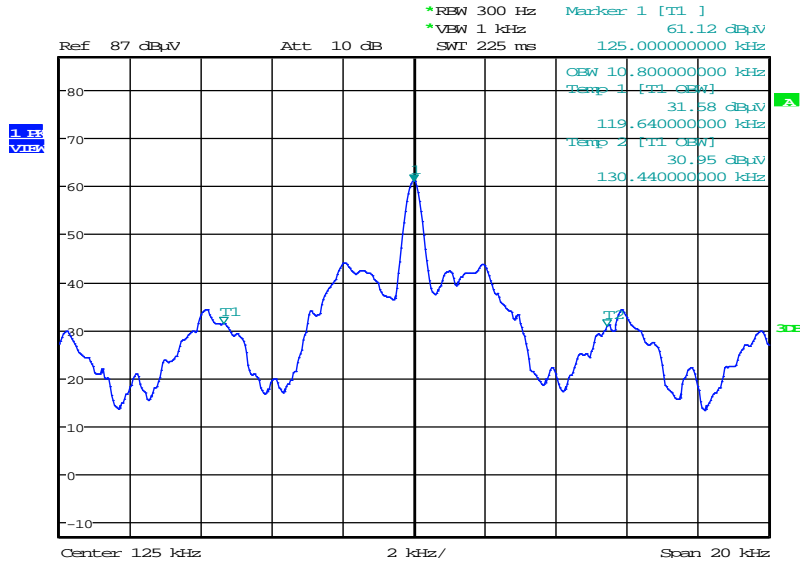

Date: 8.MAY.2019 12:08:19

Plot 2: 99 % emission bandwidth (EUT B)

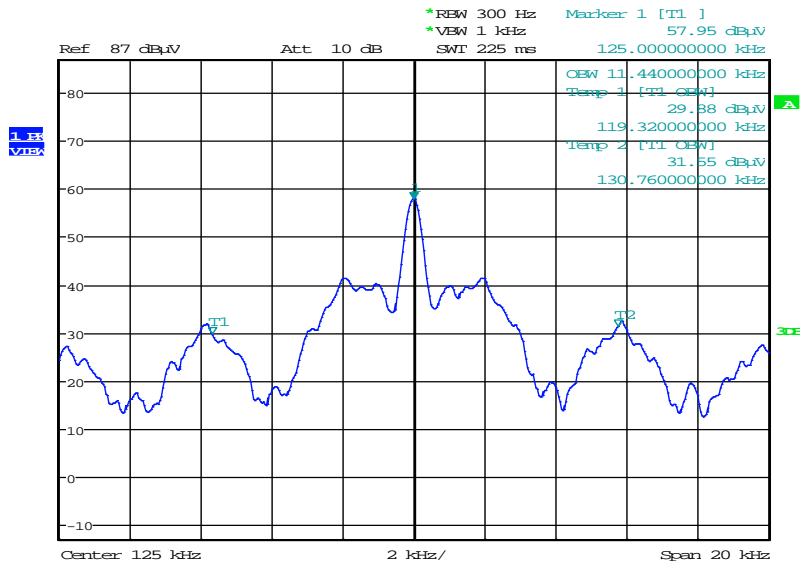

Date: 8.MAY.2019 12:11:13

11.2 Field strength of the fundamental

Measurement:

The maximum detected field strength for the carrier signal.

Measurement parameters	
Detector:	Quasi peak / peak (worst case)
Resolution bandwidth:	9 kHz
Video bandwidth:	≥ 3x RBW
Trace mode:	Max hold
Used test setup	See sub clause 6.2A
Measurement uncertainty:	See sub clause 8

Limit:

FCC & IC		
Frequency (MHz)	Field strength (dBµV/m)	Measurement distance (m)
1.705 – 30.0	2400/F (kHz) (19.2 dBµV/m @ 125 kHz)	300

Recalculation:

According to ANSI C63.10		
Frequency	Formula	Correction value
125 kHz	$FS_{limit} = FS_{max} - 40 \log\left(\frac{d_{nearfield}}{d_{measure}}\right) - 20 \log\left(\frac{d_{limit}}{d_{nearfield}}\right)$ <p> FS_{limit} is the calculation of field strength at the limit distance, expressed in dBµV/m FS_{max} is the measured field strength, expressed in dBµV/m $d_{nearfield}$ is the $\lambda/2\pi$ distance $d_{measure}$ is the distance of the measurement point from EUT d_{limit} is the reference limit distance </p>	-82.1 (from 3 to 300m)

Result:

EUT A

Field strength of the fundamental		
Frequency	125 kHz	
Distance	@ 3 m	@ 300 m
Measured / calculated value (peak measurement)	35.8 dB μ V/m	-46.3 dB μ V/m
Measured / calculated value (QP measurement)	31.7 dB μ V/m	-50.4 dB μ V/m

EUT B

Field strength of the fundamental		
Frequency	125 kHz	
Distance	@ 3 m	@ 300 m
Measured / calculated value (peak measurement)	37.2 dB μ V/m	-44.9 dB μ V/m
Measured / calculated value (QP measurement)	33.3 dB μ V/m	-48.8 dB μ V/m

11.3 Field strength of the harmonics and spurious

Measurement:

The maximum detected field strength for the harmonics and spurious.

Measurement parameters	
Detector:	Quasi peak / average or peak (worst case – pre-scan)
Resolution bandwidth:	F < 150 kHz: 200 Hz 150 kHz < F < 30 MHz: 9 kHz 30 MHz < F < 1 GHz: 120 kHz
Video bandwidth:	F < 150 kHz: 1 kHz 150 kHz < F < 30 MHz: 100 kHz 30 MHz < F < 1 GHz: 300 kHz
Trace mode:	Max hold
Used test setup:	9 kHz to 30 MHz: see sub clause 6.2A 30 MHz to 1 GHz: see sub clause 6.1A
Measurement uncertainty:	See sub clause 8

Limit:

FCC & IC		
Frequency (MHz)	Field strength (dB μ V/m)	Measurement distance (m)
0.009 – 0.490	2400/F(kHz)	300
0.490 – 1.705	24000/F(kHz)	30
1.705 – 30	30 (29.5 dB μ V/m)	30
30 – 88	100 (40 dB μ V/m)	3
88 – 216	150 (43.5 dB μ V/m)	3
216 – 960	200 (46 dB μ V/m)	3

Result: Valid for EUT A and B

Detected emissions			
Frequency (MHz)	Detector	Resolution bandwidth (kHz)	Detected value
All emissions were more than 10 dB below the limit. For emissions between 30 MHz and 1 GHz see result table below the plots.			

Plots: EUT A

Plot 1: 9 kHz – 30 MHz, magnetic emissions

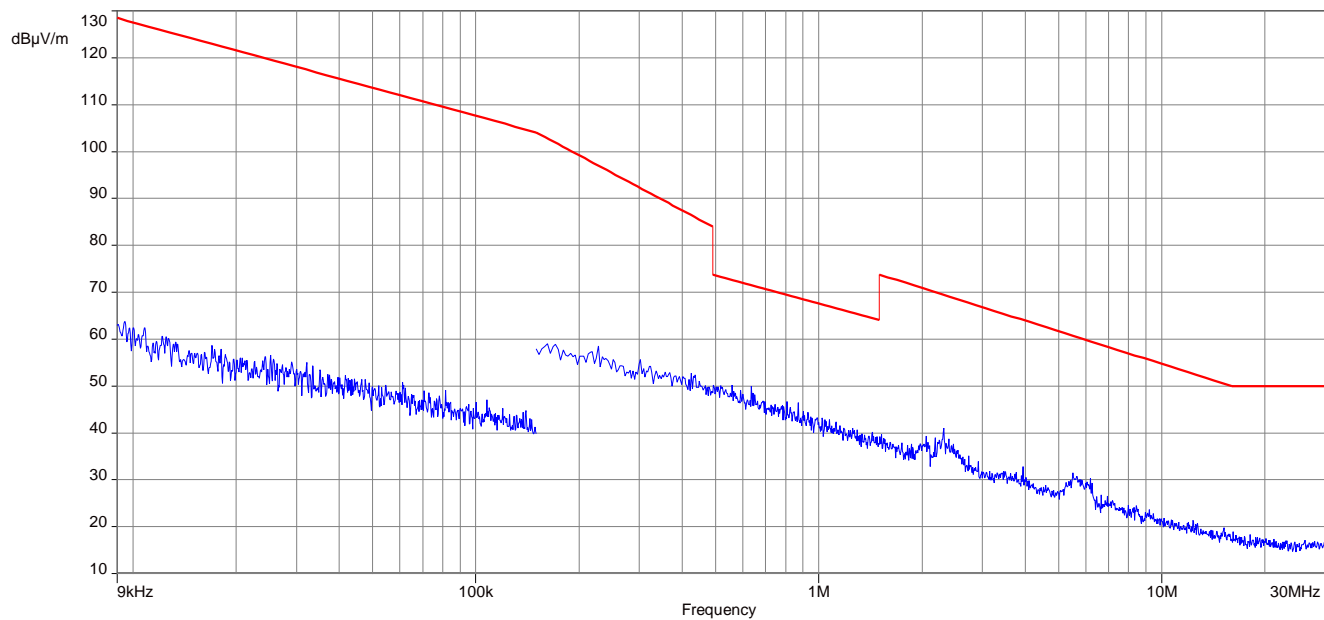

Plot 2: 30 MHz – 1 GHz, vertical and horizontal polarization

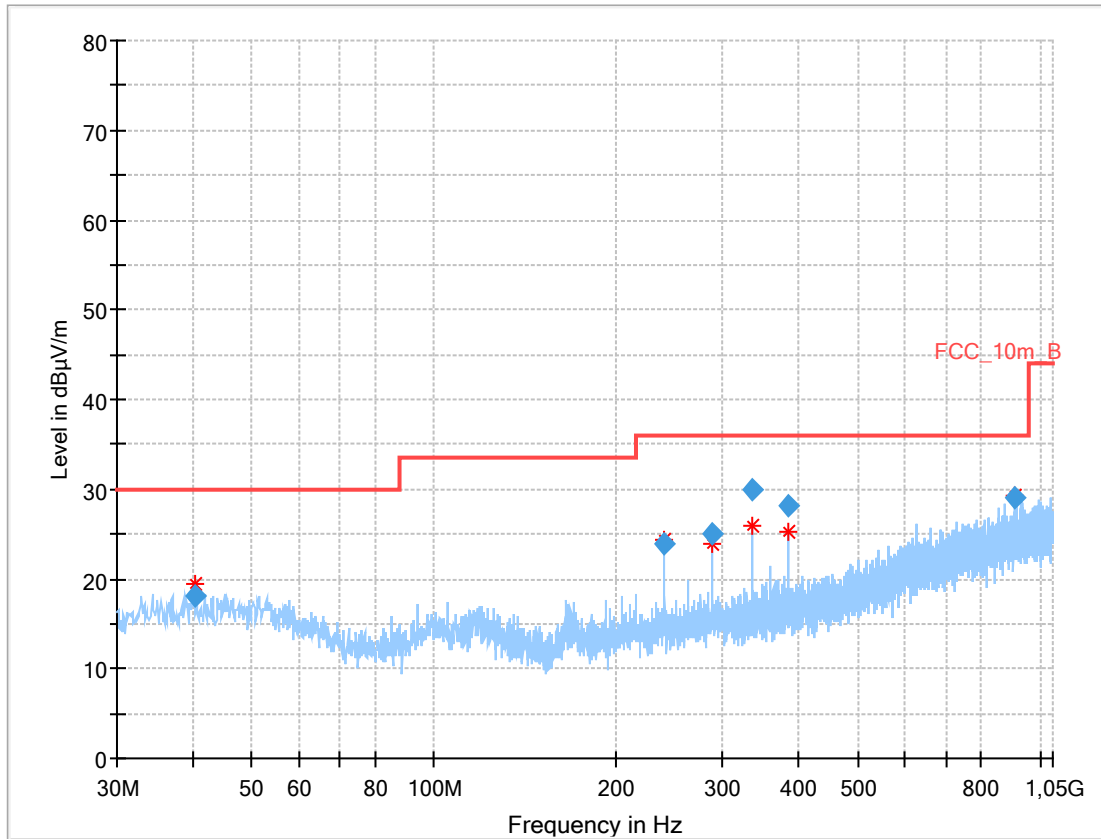

Final_Result

Frequency (MHz)	QuasiPeak (dBµV/m)	Limit (dBµV/m)	Margin (dB)	Meas. Time (ms)	Bandwidth (kHz)	Height (cm)	Pol	Azimuth (deg)	Corr. (dB/m)
40.284	18.00	30.0	12.00	1000	120	101.0	H	272.0	14
239.972	24.01	36.0	11.99	1000	120	101.0	V	67.0	13
288.003	25.09	36.0	10.91	1000	120	101.0	V	67.0	14
335.993	30.02	36.0	5.98	1000	120	170.0	H	112.0	16
384.004	28.07	36.0	7.93	1000	120	170.0	H	112.0	16
911.049	29.06	36.0	6.94	1000	120	170.0	V	166.0	24

Plots: EUT B

Plot 1: 9 kHz – 30 MHz, magnetic emissions

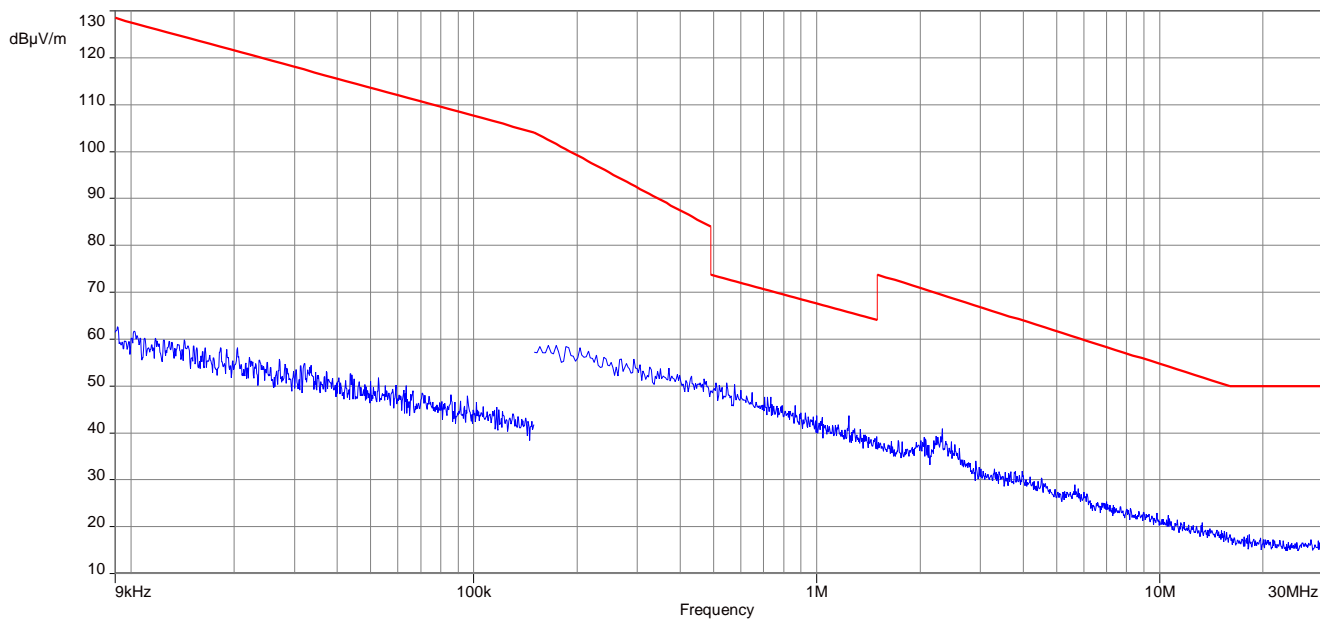

Plot 2: 30 MHz – 1 GHz, vertical and horizontal polarization

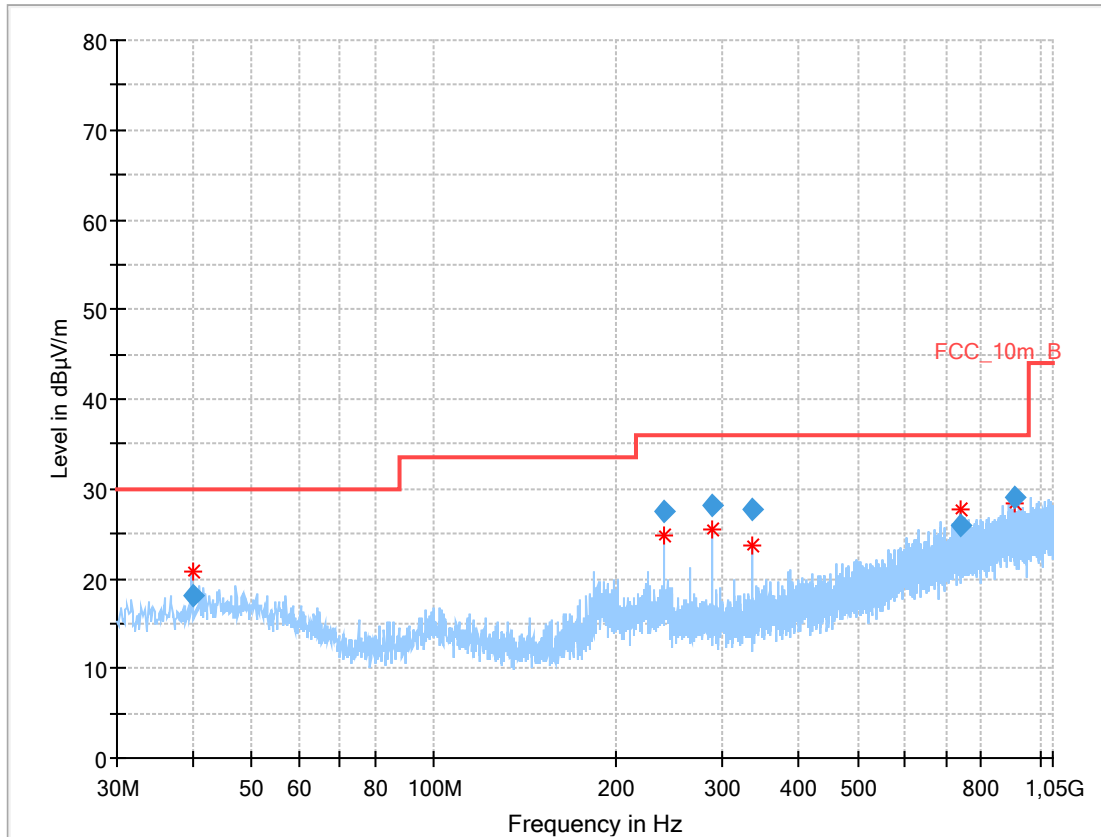

Final_Result

Frequency (MHz)	QuasiPeak (dBµV/m)	Limit (dBµV/m)	Margin (dB)	Meas. Time (ms)	Bandwidth (kHz)	Height (cm)	Pol	Azimuth (deg)	Corr. (dB/m)
40.014	17.99	30.0	12.01	1000	120	102.0	H	158.0	14
239.999	27.48	36.0	8.52	1000	120	98.0	V	-22.0	13
287.992	28.25	36.0	7.75	1000	120	170.0	H	76.0	14
335.991	27.69	36.0	8.31	1000	120	170.0	H	75.0	16
737.909	26.02	36.0	9.98	1000	120	170.0	V	-13.0	22
907.674	29.13	36.0	6.87	1000	120	170.0	V	292.0	24

11.4 Conducted limits

Measurement:

Measurement of the conducted spurious emissions for an intentional radiator that is designed to be connected to the public utility (AC) power line.

Measurement parameters	
Detector:	Quasi peak / average or peak (worst case – pre-scan)
Resolution bandwidth:	F < 150 kHz: 200 Hz F > 150 kHz: 9 kHz
Video bandwidth:	F < 150 kHz: 1 kHz F > 150 kHz: 100 kHz
Trace mode:	Max hold
Used test setup	See sub clause 6.3A
Measurement uncertainty:	See sub clause 8

Limit:

FCC & IC		
Frequency (MHz)	Quasi-peak (dBµV/m)	Average (dBµV/m)
0.15 – 0.5	66 to 56*	56 to 46*
0.5 – 5	56	46
5 – 30.0	60	50

Result: Valid for EUT A and B

Detected emissions			
Frequency (MHz)	Detector	Resolution bandwidth (kHz)	Detected value
See result table below the plots.			

Plots EUT A:

Plot 1: 150 kHz to 30 MHz, phase line

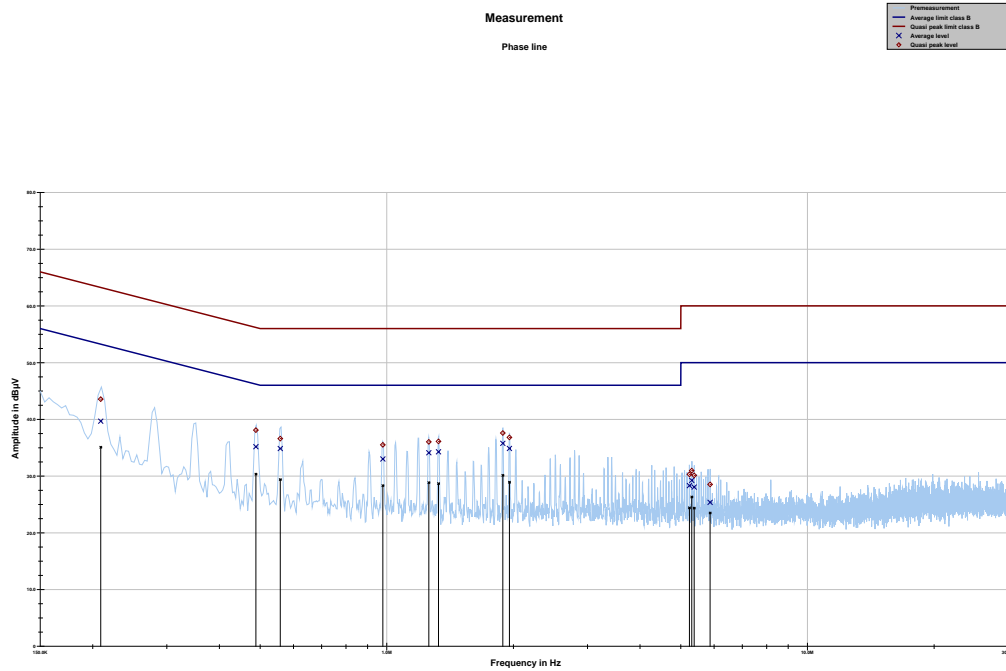

Project ID: 1-8237/19-02-02

Frequency MHz	Quasi peak level dBµV	Margin quasi peak dB	Limit QP dBµV	Average level dBµV	Margin average dB	Limit AV dBµV
0.208953	43.55	19.69	63.247	39.67	14.65	54.316
0.488583	38.09	18.10	56.192	35.18	11.15	46.326
0.558143	36.60	19.40	56.000	34.84	11.16	46.000
0.978769	35.50	20.50	56.000	33.02	12.98	46.000
1.258869	36.03	19.97	56.000	34.11	11.89	46.000
1.327489	36.12	19.88	56.000	34.27	11.73	46.000
1.887587	37.59	18.41	56.000	35.76	10.24	46.000
1.956288	36.82	19.18	56.000	34.86	11.14	46.000
5.241731	30.30	29.70	60.000	28.32	21.68	50.000
5.309646	30.96	29.04	60.000	29.23	20.77	50.000
5.379399	30.12	29.88	60.000	28.06	21.94	50.000
5.868864	28.53	31.47	60.000	25.37	24.63	50.000

Plot 2: 150 kHz to 30 MHz, neutral line

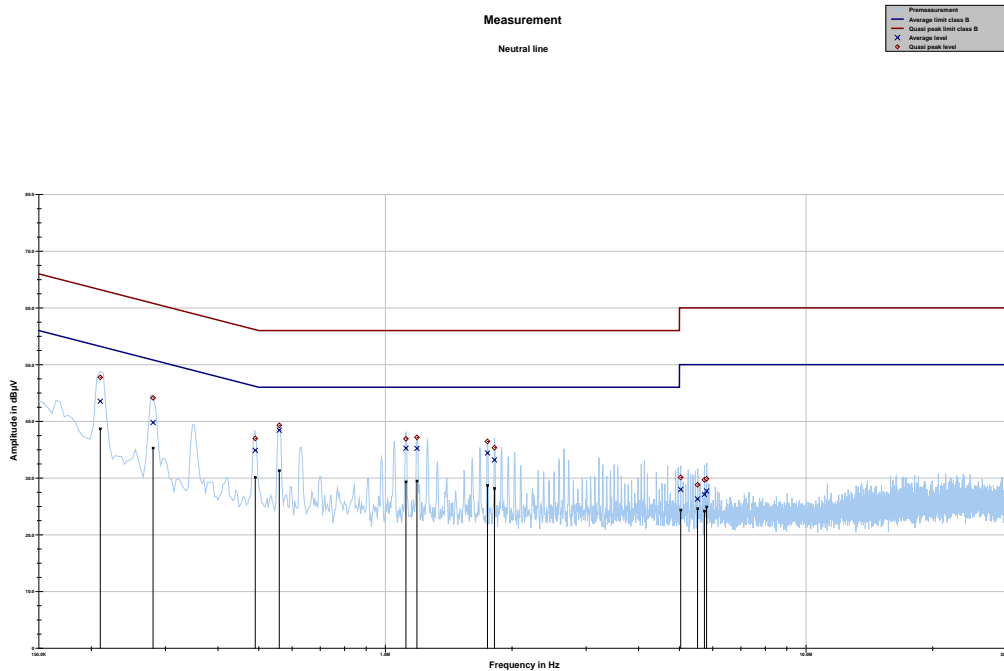

Project ID: 1-8237/19-02-02

Frequency MHz	Quasi peak level dBµV	Margin quasi peak dB	Limit QP dBµV	Average level dBµV	Margin average dB	Limit AV dBµV
0.210024	47.75	15.45	63.204	43.54	10.75	54.285
0.280359	44.13	16.67	60.805	39.79	12.48	52.275
0.490587	37.00	19.16	56.158	34.88	11.38	46.269
0.559273	39.31	16.69	56.000	38.44	7.56	46.000
1.118789	36.91	19.09	56.000	35.26	10.74	46.000
1.188602	37.18	18.82	56.000	35.22	10.78	46.000
1.747967	36.45	19.55	56.000	34.41	11.59	46.000
1.816693	35.36	20.64	56.000	33.21	12.79	46.000
5.034095	30.12	29.88	60.000	27.99	22.01	50.000
5.520387	28.80	31.20	60.000	26.31	23.69	50.000
5.732649	29.67	30.33	60.000	27.11	22.89	50.000
5.800503	29.87	30.13	60.000	27.73	22.27	50.000

Plots EUT B:

Plot 1: 150 kHz to 30 MHz, phase line

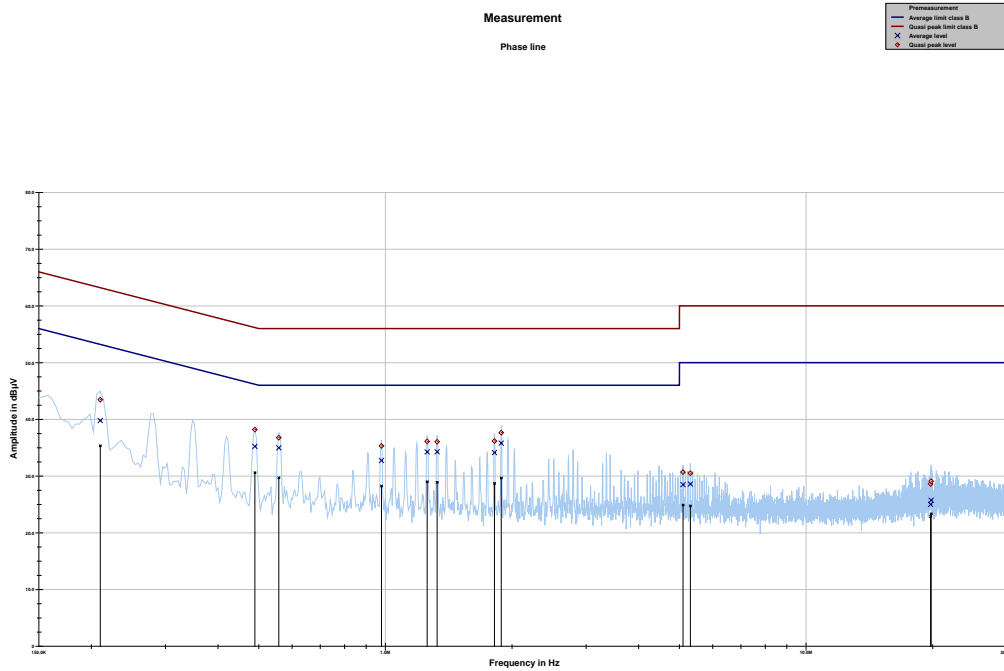

Project ID: 1-8237/19-02-02

Frequency	Quasi peak level	Margin quasi peak	Limit QP	Average level	Margin average	Limit AV
MHz	dBµV	dB	dBµV	dBµV	dB	dBµV
0.209989	43.46	19.75	63.206	39.79	14.50	54.286
0.489598	38.19	17.98	56.175	35.23	11.07	46.297
0.558016	36.77	19.23	56.000	34.98	11.02	46.000
0.978514	35.31	20.69	56.000	32.74	13.26	46.000
1.256605	36.11	19.89	56.000	34.26	11.74	46.000
1.327358	36.04	19.96	56.000	34.28	11.72	46.000
1.816883	36.18	19.82	56.000	34.14	11.86	46.000
1.885671	37.66	18.34	56.000	35.80	10.20	46.000
5.098497	30.70	29.30	60.000	28.48	21.52	50.000
5.307886	30.49	29.51	60.000	28.59	21.41	50.000
19.766230	28.61	31.39	60.000	25.00	25.00	50.000
19.833674	29.08	30.92	60.000	25.73	24.27	50.000

Plot 2: 150 kHz to 30 MHz, neutral line

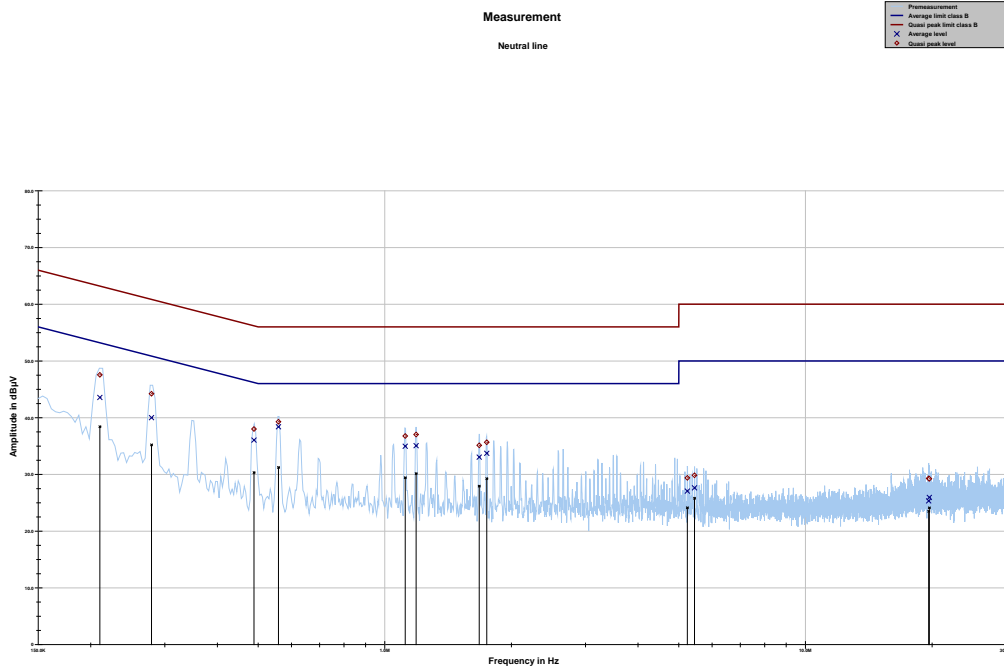

Project ID: 1-8237/19-02-02

Frequency MHz	Quasi peak level dBµV	Margin quasi peak dB	Limit QP dBµV	Average level dBµV	Margin average dB	Limit AV dBµV
0.210238	47.54	15.65	63.196	43.56	10.71	54.279
0.278867	44.22	16.63	60.850	40.00	12.32	52.318
0.488695	38.00	18.19	56.190	36.04	10.29	46.323
0.558841	39.27	16.73	56.000	38.40	7.60	46.000
1.118585	36.76	19.24	56.000	34.97	11.03	46.000
1.187099	37.03	18.97	56.000	35.07	10.93	46.000
1.677292	35.13	20.87	56.000	33.04	12.96	46.000
1.747627	35.67	20.33	56.000	33.72	12.28	46.000
5.237323	29.38	30.62	60.000	27.05	22.95	50.000
5.448995	29.85	30.15	60.000	27.63	22.37	50.000
19.627479	29.30	30.70	60.000	25.32	24.68	50.000
19.697614	29.21	30.79	60.000	25.94	24.06	50.000

12 Observations

No observations except those reported with the single test cases have been made.

Annex A Glossary

EUT	Equipment under test
DUT	Device under test
UUT	Unit under test
GUE	GNSS User Equipment
ETSI	European Telecommunications Standards Institute
EN	European Standard
FCC	Federal Communications Commission
FCC ID	Company Identifier at FCC
IC	Industry Canada
PMN	Product marketing name
HMN	Host marketing name
HVIN	Hardware version identification number
FVIN	Firmware version identification number
EMC	Electromagnetic Compatibility
HW	Hardware
SW	Software
Inv. No.	Inventory number
S/N or SN	Serial number
C	Compliant
NC	Not compliant
NA	Not applicable
NP	Not performed
PP	Positive peak
QP	Quasi peak
AVG	Average
OC	Operating channel
OCW	Operating channel bandwidth
OBW	Occupied bandwidth
OOB	Out of band
DFS	Dynamic frequency selection
CAC	Channel availability check
OP	Occupancy period
NOP	Non occupancy period
DC	Duty cycle
PER	Packet error rate
CW	Clean wave
MC	Modulated carrier
WLAN	Wireless local area network
RLAN	Radio local area network
DSSS	Dynamic sequence spread spectrum
OFDM	Orthogonal frequency division multiplexing
FHSS	Frequency hopping spread spectrum
GNSS	Global Navigation Satellite System
C/N₀	Carrier to noise-density ratio, expressed in dB-Hz

Annex B Document history

Version	Applied changes	Date of release
-/-	Initial release	2019-06-03
-A	Test results reduced to CTP series	2019-06-11

Annex C Accreditation Certificate – D-PL-12076-01-04

first page	last page
 <p>The first page of the accreditation certificate includes the DAkkS logo, the name 'Deutsche Akkreditierungsstelle GmbH', and accreditation details for CTC advanced GmbH. It states that the company is accredited for Telecommunication (TC) and Electromagnetic Compatibility (EMC) for Canadian Standards. The certificate is valid until 21.04.2021. A signature of Udo Steg, Head of Division, is present at the bottom.</p>	 <p>The last page of the certificate provides contact information for three offices: Berlin, Frankfurt am Main, and Braunschweig. It also contains legal disclaimers regarding the publication of extracts and the accreditation's validity, along with website links for EA, ILAC, and IAF.</p>

Note: The current certificate annex is published on the website (link see below) of the Accreditation Body DAkkS or may be received by CTC advanced GmbH on request

<https://www.dakks.de/as/ast/d/D-PL-12076-01-04.pdf>

Annex D Accreditation Certificate – D-PL-12076-01-05

first page	last page
 <p>The first page of the accreditation certificate features the DAKKS logo (Deutsche Akkreditierungsstelle) and the text: 'Deutsche Akkreditierungsstelle GmbH', 'Entrusted according to Section 8 subsection 1 AkkStelleG in connection with Section 1 subsection 1 AkkStelleGBV', and 'Signatory to the Multilateral Agreements of EA, ILAC and IAF for Mutual Recognition'. The main heading is 'Accreditation' with the German national emblem. It states: 'The Deutsche Akkreditierungsstelle GmbH attests that the testing laboratory CTC advanced GmbH, Untertürkheimer Straße 6-10, 66117 Saarbrücken, is competent under the terms of DIN EN ISO/IEC 17025:2005 to carry out tests in the following fields: Telecommunication (FCC Requirements)'. At the bottom, it includes the registration number 'D-PL-12076-01-05', the date 'Frankfurt am Main, 11.01.2019', and a signature of 'Uwe Zimmermann, Head of Division'.</p>	 <p>The last page of the accreditation certificate lists the office addresses: 'Office Berlin, Spittelmarkt 10, 10117 Berlin', 'Office Frankfurt am Main, Europa-Allee 52, 60327 Frankfurt am Main', and 'Office Braunschweig, Bundesallee 100, 38116 Braunschweig'. It contains several paragraphs of legal text regarding the approval of extracts, the scope of accreditation, and the legal basis for the accreditation (Act on the Accreditation Body (AkkStelleG) of 31 July 2009). It also provides website links for EA (www.european-accreditation.org), ILAC (www.ilac.org), and IAF (www.iaf.eu).</p>

Note: The current certificate annex is published on the website (link see below) of the Accreditation Body DAKKS or may be received by CTC advanced GmbH on request

<https://www.dakks.de/as/ast/d/D-PL-12076-01-05.pdf>

END OF TEST REPORT