

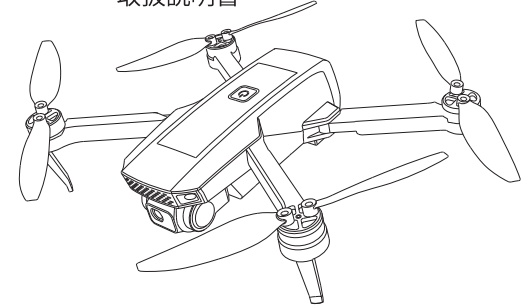

# D20S

User Manual  
Gebrauchsanweisung  
取扱説明書

v1.0



usa@deerc.com (USA)  
jp@deerc.com (JP)

eu@deerc.com (EU)  
au@deerc.com (AU)

+1 (334) 336-0888

# CONTENTS

---

English	01-46
Deutsch	47-90
日本語	91-135

## 1 Product Profile

---

01	Package Contents
02	Diagram of the Drone
03	Diagram of the Transmitter

## 3 Drone Functions

---

22	Flight Functions
33	Attitude Adjustment
35	Stabilization Functions

## 2 Operation Guide

---

07	Battery Preparation	15	Flight
09	Pre-Flight Preparations		
14	Pre-Flight Checklist		

## 4 Appendix

---

38	Specifications	42	Compliance Information
40	Contact Us		
41	Troubleshooting		

# Reading Guidance

## Icon

“⚠️” essential precautions. “💡” tips for operation and usage.

## Recommended Steps

Our product offers both tutorial videos and the following resources:

- Disclaimer and Safety Guidelines
- Quick Start Guide
- User Manual

For a smooth start, we suggest watching the tutorial videos and reviewing the “Disclaimer and Safety Guidelines” first. Then, familiarize yourself with the basics through the “Quick Start Guide”. For a comprehensive understanding, delve into the “User Manual”.

## Access Tutorial Videos

To ensure you're using the product safely and correctly, scan the QR code below to view our tutorial videos.



## Download the DEERC FPV App

Simply scan the QR code below.



iOS



Android APP on Google play

💡 Required Operating Systems: iOS 12.0 or later/Android 5.0 or later.

1.1 Package Contents >>

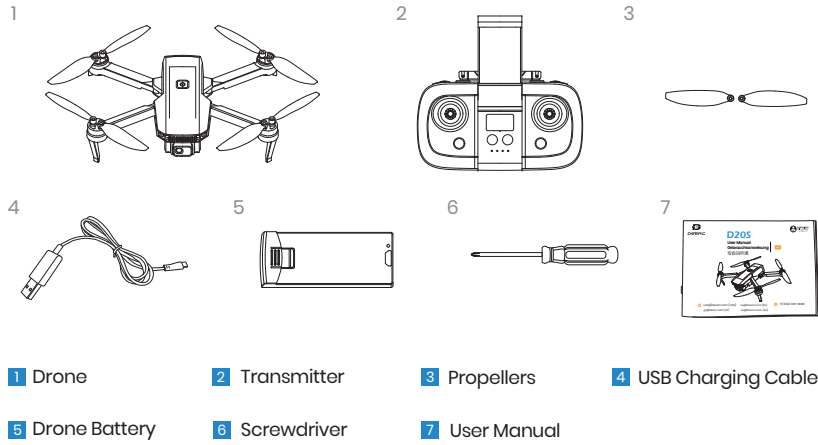

1.2 Diagram of the Drone >>

Drone

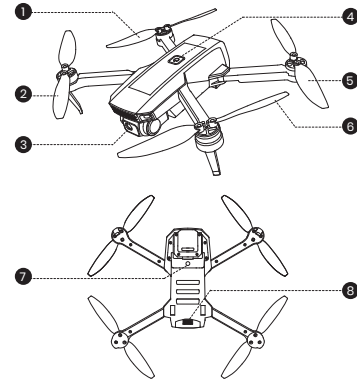

- 1 Propeller A
- 2 Propeller B
- 3 Camera
- 4 Power Switch: long press
- 5 Propeller B
- 6 Propeller A
- 7 Optical Flow Positioning Lens
- 8 Drone Battery

💡 Turning on/off: Long press the power switch (🔌) on the drone to turn it on/off.

## 1.3 Diagram of the Transmitter &gt;&gt;

## The Transmitter

## ● Front:

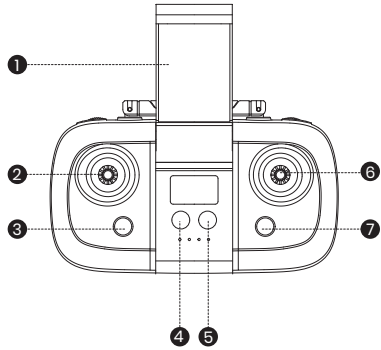

## ● Top:

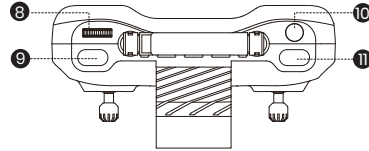

1 Phone Holder

2 Left Joystick

3 Power Switch: long press

4 Speed Switch: short press

Headless Mode: long press

5 Trimmer: long press

6 Right Joystick

7 Takeoff/Landing: short press

Emergency Stop: long press

8 Camera Angle Adjustment

9 Take Photo: short press

Record Video: long press

10 High Speed Rotation: short press

Circle Fly: long press

11 360°Flips: short press



💡 Turning on/off: Long press the power switch (  ) on the transmitter to turn it on/off.

## 1.3 Diagram of the Transmitter &gt;&gt;

## Joystick Mode

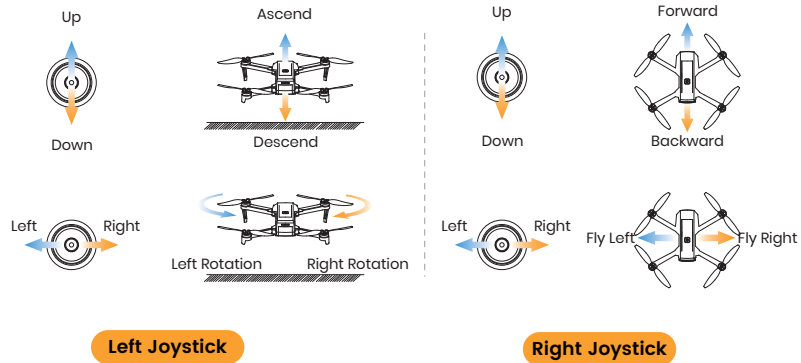
- **MODE 2** : (The default setting, i.e., left joystick as the throttle joystick.)



- **MODE 1** : To enter MODE 1, turn on the transmitter while holding the  button. (Please do not release the  button until the transmitter is powered on.)

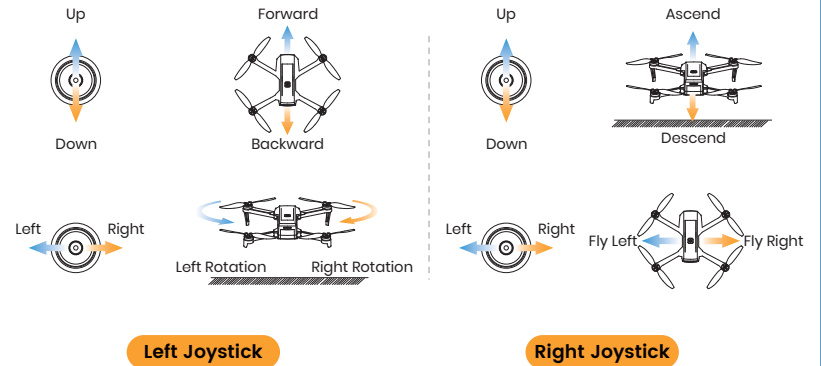

## 2.1 Battery Preparation &gt;&gt;

## Drone Battery

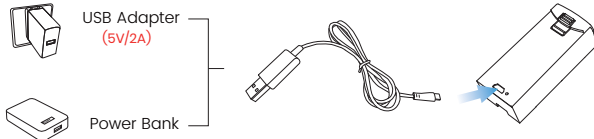

- 1 Remove the battery from the drone and connect it to a USB charging cable.
- 2 Plug the USB charging cable into a USB charging port on a power bank or a USB adapter (5V/2A).
- 3 The red light on the drone battery illuminates during charging and goes off once the battery is fully charged.
- 4 Charging time: About 150 minutes.

**\*Low Battery Signal:** The indicator lights on the drone keep flashing, and the transmitter will keep beeping.

- ⚠ Before charging, please read the instructions in the "Battery Safety" section of the "Disclaimer and Safety Guidelines" carefully!
- DO NOT charge a battery immediately after a flight as the temperature may be too high. Please wait until it cools down to room temperature before charging again.
- Please use the original charging cable to charge the battery.

07

## 2.1 Battery Preparation &gt;&gt;

## Changing Transmitter Batteries

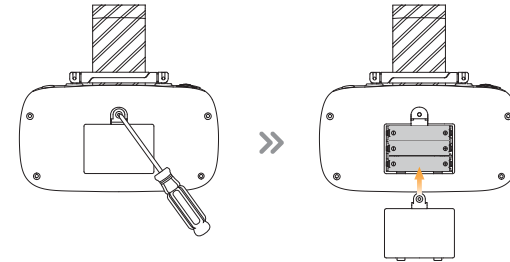

Open the battery cover on the back of the transmitter. Put in three AAA batteries (not included). Then, close the cover.

**\*Low Battery Signal:** The indicator lights on the transmitter flash slowly.

- 💡 · Install batteries carefully.
- Do not mix old and new batteries.
- Do not mix different types of batteries.

08

## 2.2 Pre-Flight Preparations &gt;&gt;

## Arms

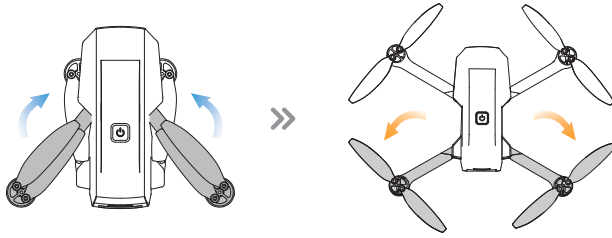

All arms of the drone are folded before the drone is packaged at the factory. First, unfold the front arms, then unfold the rear arms

## 2.2 Pre-Flight Preparations &gt;&gt;

## Propellers

- **Installation:**

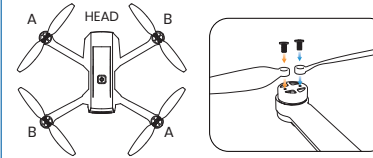

The drone will not fly unless the correct propeller is installed on the correct motor shaft. Each propeller is labeled with either an "A" or "B" on it. Secure the propeller onto the motor shaft using screws, turning each screw clockwise.

- **Removal:**

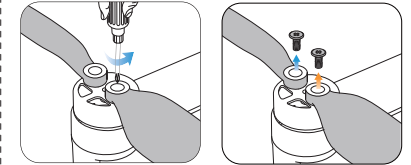

For propeller removal, use a screwdriver (provided) to rotate the screws counter-clockwise and remove the propellers. Be sure to hold the motor while detaching the propeller.

- ⚠ Please check that the propellers are properly installed and tightened before each flight.
- Exercise caution when attaching/detaching the propellers to prevent any cuts or injuries.
- The propellers are installed before the drone is packaged at the factory.



## 2.2 Pre-Flight Preparations >>

### Drone Battery

#### ● Installation:

\* Before installing the battery, please check if it has a detachable insulation pad/band. If yes, remove it.

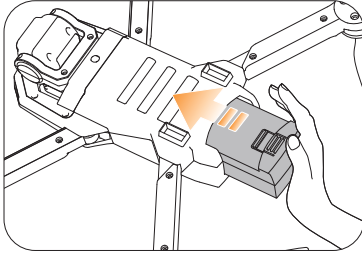

Push the battery correctly into the drone. Make sure that you hear a click sound, which indicates that the battery is firmly installed.

#### ● Removal:

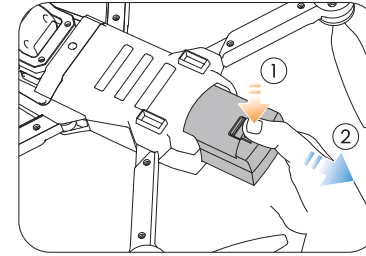

Press the lock button on the battery, and pull the battery out from the drone.

⚠ The battery should be installed firmly. Otherwise, the flight safety of your drone may be affected. The drone may crash due to a power-cut during the flight.

## 2.2 Pre-Flight Preparations &gt;&gt;

## Phone Holder

Expand the phone holder and place your mobile phone in it. Adjust the clamp to secure your mobile phone.

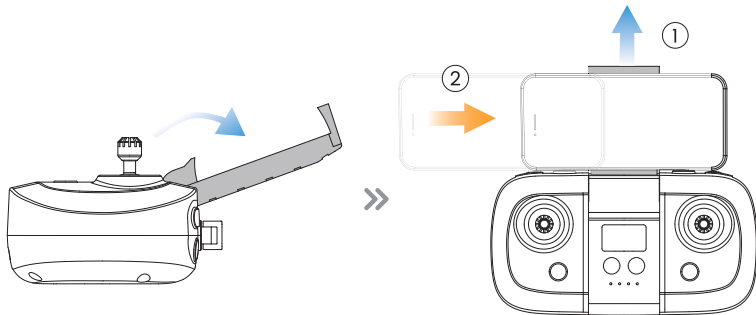

## 2.3 Pre-Flight Checklist &gt;&gt;

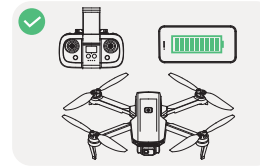

Make sure the transmitter, the mobile phone and the drone battery are fully charged.

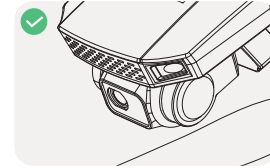

Make sure that the camera is clean.

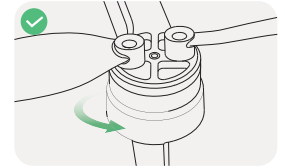

Make sure that there is nothing obstructing the motors.

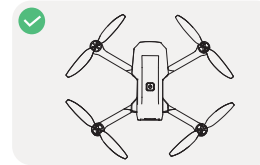

Make sure the drone arms are unfolded.

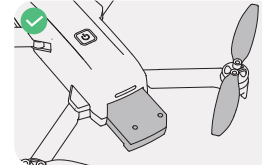

Make sure the drone battery and the propellers are mounted securely.



Please ensure that you use only accessories manufactured by our company.

## 2.4 Flight &gt;&gt;

## Pairing

- All of the operations shown in this manual are demonstrated using **MODE 2**.
- You must keep your drone in visual line of sight all the time. If you can't see it, you can't control it.

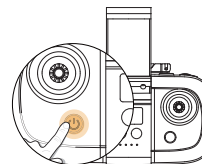
**2 Turning on the Transmitter**

Long press the power switch on the transmitter to turn it on; its indicator lights will begin to flash.

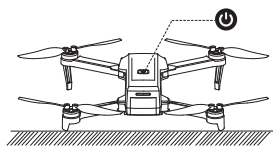
**1 Turning on the drone**

Set the drone on a flat, level surface, positioning it so that the front faces away from you and the tail points towards you. Long press the power switch to turn on the drone. The indicator lights on the drone begin to flash.

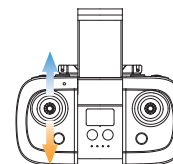
**3 Pairing**

Move the left joystick up and then back down to pair the drone with the transmitter. Successful pairing is confirmed when the indicator lights on both the drone and the transmitter become steady.

## 2.4 Flight &gt;&gt;

## Wi-Fi Connection

💡 Make sure the pairing has finished before going to the Wi-Fi settings on your phone.



- 1 Go to the Wi-Fi settings on your phone.
- 2 Connect to the drone's Wi-Fi network: **DeercFPV-\*\*\*\*\***.
- 3 Run the **DEERC FPV** app. A successful connection is confirmed **when the drone's live video feed is displayed within the app interface**.



· Connecting your phone to the drone's Wi-Fi may take some time. Please remain patient and wait for the connection to be established successfully.

· For optimal connectivity, if you're experiencing issues with the WIFI connection or the image transmission in the APP isn't displaying, it's advised to disable your phone's Bluetooth, Mobile Data, and VPN. Alternatively, switch your phone to airplane mode and attempt to reconnect.



The Wi-Fi network created by the drone does not have internet access. As a result, your cellphone might:

- Notify you that the connection isn't secure,
  - Indicate there's no internet connection, or
  - Suggest switching to cellular data.
- (The exact wording may vary based on cellphone models.)

Please disregard these messages. If prompted, select the option to remain connected to the current Wi-Fi.

## 2.4 Flight &gt;&gt;

## Gyro-Calibration



Make sure to place the drone on a level surface before calibrating the gyro. Simultaneously push the left joystick and the right joystick to the bottom left corner to calibrate the gyro. The indicator lights on the drone will blink, then turn solid, which indicates that the calibration is completed.

💡 To ensure a stable flight, we suggest that the pilot calibrates the gyro every time after pairing the drone and after a crash.

## 2.4 Flight &gt;&gt;

## Unlocking the Motors

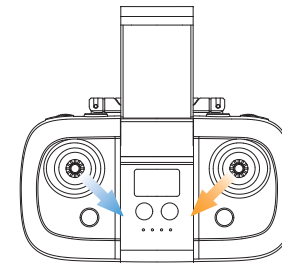

Simultaneously push the left joystick to the bottom right corner and the right joystick to the bottom left corner. The motors will rotate, and the drone is unlocked.

💡 To lock the motors: Simply repeat the above steps. The motors will halt instantly.

## 2.4 Flight &gt;&gt;

## Takeoff/Landing

💡 Remember to unlock the motors before takeoff.

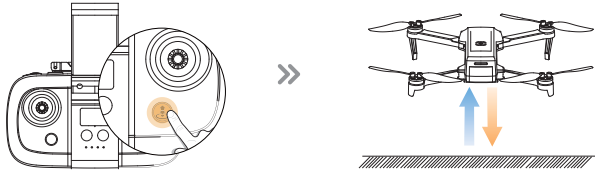



**Takeoff** Short press the  button, the drone will take off automatically and hover at 4 ft. Now you can control the drone by using the joysticks.

**Landing** During the flight, short press the  button, the drone will land on the ground automatically.

## 3.1 Flight Functions &gt;&gt;

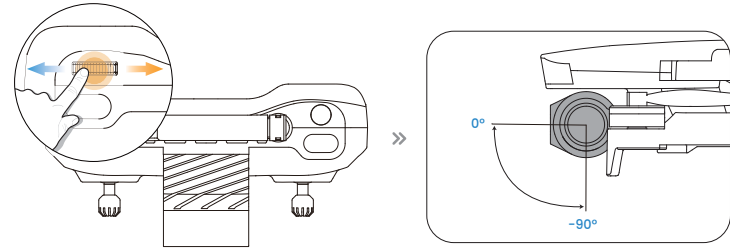
## Camera Angle Adjustment





Adjust the camera angle by scrolling the camera adjustment dial .  
(tilt range: -90°~ 0°)

## 3.1 Flight Functions &gt;&gt;

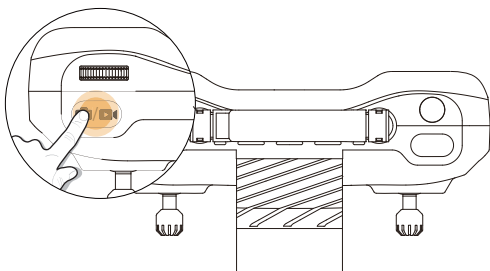
## Take Photo/Record Video





**Take Photo:** Short press the  button on the transmitter to take a photo. The transmitter will beep once, signaling that a photo has been taken.

**Record Video:** Long press the  button on the transmitter. The transmitter will long beep once, indicating that video recording has started. Press the same button again to stop recording.

## 3.1 Flight Functions &gt;&gt;

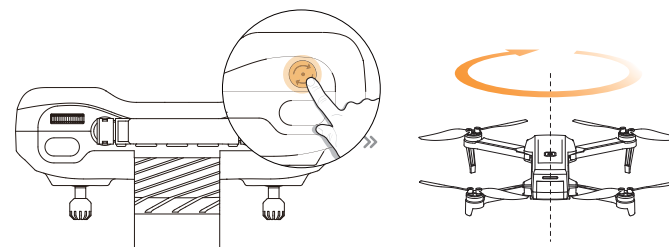
## High Speed Rotation



Short press the  button, the drone will enter the High Speed Rotation mode. Exit the High Speed Rotation mode by pressing the same button again or pushing the right joystick in any direction.

## 3.1 Flight Functions &gt;&gt;

## Circle Fly

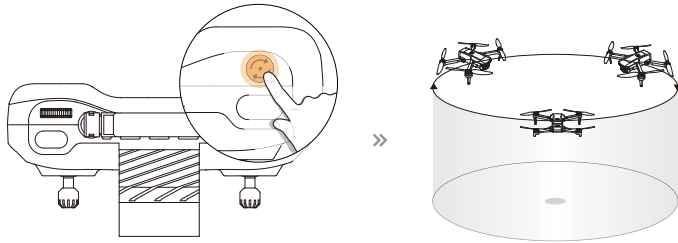



Long press the  button, the drone will enter the Circle Fly mode. Exit the Circle Fly mode by long pressing the same button again or pushing the right joystick in any direction.

## 3.1 Flight Functions &gt;&gt;

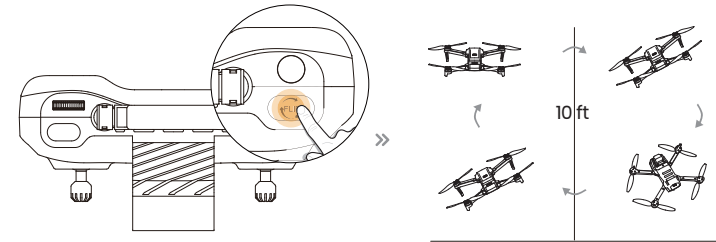
## 360° Flips



After you get familiar with all the functions of the drone, you can try this amazing flip mode. When the drone is at least 10 ft from the ground, press down on the  button, then push the right joystick in any direction. The drone will perform a flip toward that direction.

 360° Flip functions better when the battery is fully charged.



## 3.1 Flight Functions &gt;&gt;

## Speed Switch

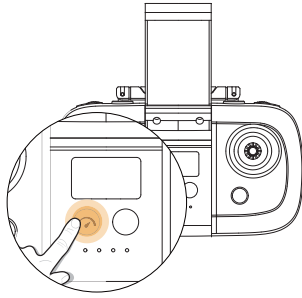

This drone offers three speed modes: Low, Middle and High. By default, it's set to Low speed.

To toggle between the modes, give the  button a short press. The transmitter beeps once to indicate Low Speed, beeps twice to indicate Medium Speed and beeps three times to indicate High Speed.

## 3.1 Flight Functions &gt;&gt;

## Headless Mode

The Headless Mode is a great training tool for beginner pilots. It is also useful when the drone is too far from the pilot (**which makes it difficult to tell its orientation**). It keeps the drone traveling forward, backward, left, or right when you move the right joystick in those directions, regardless of which way the front of the drone is pointed.

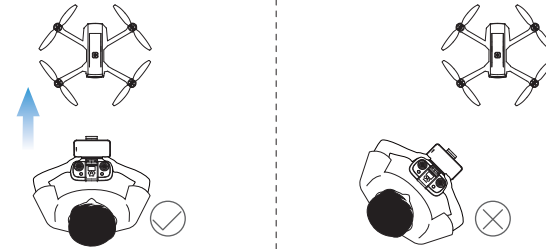



The pilot should stay facing the same direction that the drone's head points to when it takes off.

## 3.1 Flight Functions &gt;&gt;

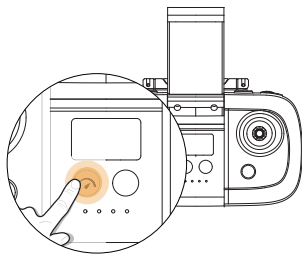
## Headless Mode



- 1 **ACTIVATING:** Long press the  button to activate this mode. While in Headless Mode, the drone's indicator lights will flash continuously, and the transmitter will keep beeping.
- 2 **DEACTIVATING:** Long press the  button once more. A prolonged beep will sound, and the drone's indicator lights will return to a steady glow, indicating the drone has successfully exited Headless Mode.

## \* Why is the orientation of the drone important?

**In normal flying mode,** the control of the drone movement can sometimes be counter-intuitive for beginners. For instance, when the drone is in the air with its head pointing to your right, if you push the right joystick forward, the drone will fly to your right, instead of flying forward.

**With the headless mode, the drone has a fixed "head."** In Headless Mode, the drone always remembers the side its head points to during takeoff as the front side. This means that if the drone takes off with its head pointing forward, it doesn't matter how the drone is oriented in the air, when you push the right joystick forward, the drone will fly forward. Or, when its head is pointing to you, if you push the right joystick to the left, the drone will fly to your left.

## 3.1 Flight Functions &gt;&gt;

## Emergency Stop

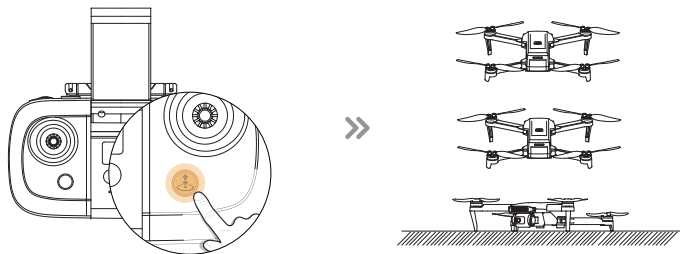

- 1 The Emergency Stop function should only be used in an emergency during the flight to avoid any damage or injury. Long Press the  button. The transmitter will long beep once. The drone will fall down immediately.

 Be aware that you risk breakage of the drone if it falls from a large distance or hits anything at a high rate of speed.

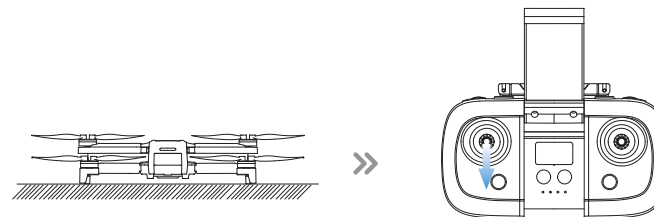

- 2 After the drone hits the ground, The drone indicator will keep on flashing. Please put the drone on a level surface again, and push the left joystick downward. The drone indicator then turn from flashing to solid, which indicates that you can use the drone now.

## 3.2 Attitude Adjustment &gt;&gt;

## Trimming

 **Trim adjustments are designed to counter drifts not caused by airflow.**

**1 Initiate Trim Mode:** Long press the Trim button.

**2 L/R Sideward Trim:**

- If the drone drifts to the left, push the right joystick to the right.
- If the drone drifts to the right, push the right joystick to the left.

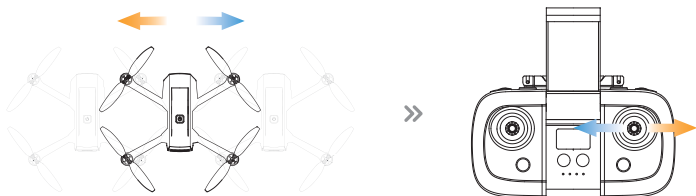

**F/B Sideward Trim:**

- If the drone drifts forward, push the right joystick downward.
- If the drone drifts backward, push the right joystick upward.

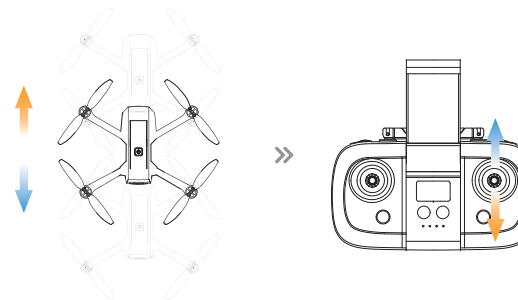

**3 Deactivate Trim Mode:** Once adjustments are made, long press the Trim button or stop operating the joysticks for 2 seconds to exit Trim Mode.

## 3.3 Stabilization Functions &gt;&gt;

## Altitude-Hold Function

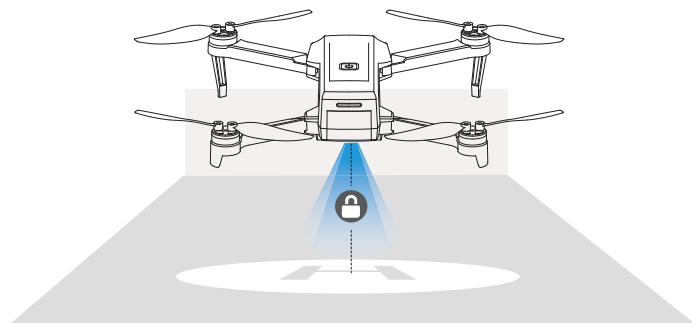

The drone is designed with an **altitude-hold** function to maintain its altitude after releasing the left joystick. (The left joystick will automatically spring back to the middle)

35

## 3.3 Stabilization Functions &gt;&gt;

## Optical Flow Positioning

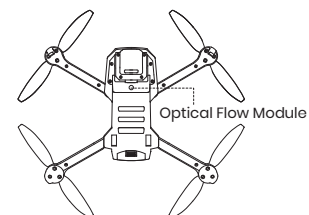

The Optical Flow Positioning System consists of a camera module, which acquires the position information of the drone through visual images to ensure precise positioning of the drone. The optimal usage height for Optical Flow Mode is 1.6-9.8ft.



- The precision of the Optical Flow Positioning System is easily affected by the light intensity and features of the surface textures. Once the image sensor is not available, your drone will switch on the altitude-hold function automatically. Please exercise utmost caution when operating the drone under these circumstances:

36

### 3.3 Stabilization Functions >>

- Fly over surfaces without clear patterns or textures.
- Fly over extremely dark or bright surfaces.
- Fly in an area where the lighting changes dramatically and frequently.
- Fly over moving surfaces or objects. (e.g., above crowds, above bushes or grasses swayed by strong winds).
- Fly over water or transparent surfaces.
- Fly over highly light reflective surfaces. (e.g., mirrors).
- Fly over monochrome surfaces (e.g. pure black, red, or green).
- Flying over surfaces with repeating identical patterns or textures (e.g., tiles with the same design).
- Flying speed should be controlled not to be too fast.
- Keep sensors clean at all times.
- DO NOT scratch or tamper with the sensors. DO NOT use the aircraft in dusty or humid environments.
- Make sure that the light is bright enough and the surface is with clear textures so that the Optical Flow Positioning can acquire the movement information through recognizing the ground textures.

### 4.1 Specifications >>

#### • DRONE :

Model: D20S	Weight: 144g/5.1oz
Max Flight Time: 15 minutes <small>(in a windless environment)</small>	Max Flight Height: 164ft/50m
Operating Temperature Range: 32° to 104°F (0° to 40°C)	
Size : 242*182*52 mm (unfolded)	127*77*52 mm (folded)

#### • DRONE BATTERY :

Capacity: 1200mAh	Voltage: 3.7V
Battery Type: Lithium-ion Polymer Battery	Energy: 4.44Wh
Charging Temperature Range: 41° to 104°F (5° to 40°C)	
Charging Time: About 150 minutes	

## 4.1 Specifications &gt;&gt;

## • TRANSMITTER:

Operating Frequency: 2410-2470MHz	Max Flight Distance: 262ft/80m <small>(outdoor and unobstructed)</small>
Battery Type: 3 × AAA Battery (not included)	
Operating Temperature Range: 32° to 104°F (0° to 40°C)	

## • CAMERA:

Operating Frequency: 2412-2462MHz	Photo Resolution: 1920×1080P
Video Resolution: 1920×1080P@25fps	Max Transmission Distance: 164ft/50m <small>(outdoor and unobstructed)</small>
Controllable Range: -90° to 0°	Photo Formats: JPEG
Video Formats: MP4	

## • USB CHARGING CABLE:

Input: 5V/2A	Rated Power: ≤10W
--------------	-------------------

## 4.2 Contact Us &gt;&gt;

Please do not hesitate to contact us if you need further support.



usa@deerc.com (America)  
eu@deerc.com (Europe)  
au@deerc.com (Australia)  
jp@deerc.com (Japan)



+1 (334) 336-0888

## 4.3 Troubleshooting &gt;&gt;

Issue	Suggested Solutions
Lag in the drone's response to the transmitter.	Transmitter battery is low. It is recommended to replace the transmitter batteries.
	Beyond the transmitter's range. It is advised to fly within a safe range.
Drone drifts.	Ineffective or poor optical flow. It is recommended not to fly the drone in dimly lit areas, on highly reflective or overly smooth surfaces, or over water. Also, avoid flying too high. (See page 36)
Unable to control drone's flight via the app.	The drone's aerial movements can be controlled by either the transmitter or the cellphone, but not both simultaneously. To use the app for flying the drone, ensure the transmitter is switched off first.
App is not functional.	Permission or compatibility issues. It is recommended to download the latest version of the app. When opening the app, ensure that all requested permissions are granted; your phone's operating system must meet the app's requirements; alternatively, try using a different phone.

## 4.4 Compliance Information &gt;&gt;

**FCC Notice:**

This device complies with part 15 of the FCC Rules. Operation is subject to the following two conditions:

- (1) This device may not cause harmful interference, and
- (2) This device must accept any interference received, including interference that may cause undesired operation.

The Supplier's Declaration of Conformity is available at the following address:

[https://www.deerc.com/Download/US/D20S\\_FCC\\_sDoC.pdf](https://www.deerc.com/Download/US/D20S_FCC_sDoC.pdf)

This equipment has been tested and found to comply with the limits for a Class B digital device, pursuant to part 15 of the FCC Rules. These limits are designed to provide reasonable protection against harmful interference in a residential installation. This equipment generates, uses and can radiate radio frequency energy and, if not installed and used in accordance with the instructions, may cause harmful interference to radio communications. However, there is no guarantee that interference will not occur in a particular installation. If this equipment does cause harmful interference to radio or television reception, which can be determined by turning the equipment off and on, the user is encouraged to try to correct the interference by one or more of the following measures:

- Reorient or relocate the receiving antenna.
- Increase the separation between the equipment and receiver.
- Connect the equipment into an outlet on a circuit different from that to which the receiver is connected.
- Consult the dealer or an experienced radio/TV technician for help.

Changes or modifications not expressly approved by the party responsible for compliance could void the user's authority to operate the equipment.



## 4.4 Compliance Information &gt;&gt;

**RF Exposure:**

The equipment complies with FCC radiation exposure limits set forth for an uncontrolled environment. This device should be installed and operated with minimum distance 20cm between the radiator & your body. (only for the drone)

**IC Notice:**

This device complies with Canada Industry licence-exempt RSS standard (s).

Operation is subject to the following two conditions:

- (1) this device may not cause interference; and
- (2) this device must accept any interference. Including interference that may cause undesired operation of the device.

**CAN ICES-003 (B):**

Avis d' Industrie Canada

Le présent appareil est conforme aux CNR d'industrie Canada applicables aux appareils radio exempts de licence. L'exploitation est autorisée aux deux conditions suivantes:

- (1) l'appareil ne doit pas produire de brouillage; et
- (2) l'utilisateur de l'appareil doit accepter le brouillage radioélectrique subi même si le brouillage est susceptible d'en compromettre le fonctionnement. mauvais fonctionnement de l'appareil. Cet appareil numérique de la classe B est conforme à la norme NMB-003 du Canada.

## 4.4 Compliance Information &gt;&gt;

**CAN NMB-003 (B):**

RF Exposure

Radiation Exposure Statement:

This equipment complies with IC radiation exposure limits set forth for an uncontrolled environment. This equipment should be installed and operated with a minimum distance of 20cm between the radiator & your body.

Déclaration d'exposition aux radiations:

Cet équipement est conforme aux limites d'exposition aux rayonnements IC établies pour un environnement non contrôlé. Cet équipement doit être installé et utilisé avec un minimum de 20 cm de distance entre la source de rayonnement et votre corps.

**EU RF Power(EIRP):** <10 dBm (2452MHz-2474 MHz)

**Caution:**

1. The max operating of the EUT is 45°C, and shouldn't be lower than -10°C.
2. The device complies with RF specifications when the device used at 0mm from your body.
3. Declaration of Conformity.

We, Xiamen Huoshiquan Import & Export CO.,LTD

hereby, declare that the compliance of the essential requirements with the Directive 2014/53/EU, the RoHS Directive 2011/65/EU and Safety Directive 2009/48/EC have been fully fulfilled on our product with

## 4.4 Compliance Information &gt;&gt;

**indication below:**

Product Name: Remote control four axis series

Model/Mark:D20S/Deerc

The Statement of compliance is available at the following address:

[http://www.deerc.com/Download/CE/D20S\\_EU\\_DOC.pdf](http://www.deerc.com/Download/CE/D20S_EU_DOC.pdf)

This product can be used among EU member states.

**MANUFACTURER INFORMATION:**

Manufactured by

Xiamen Huoshiquan Import & Export CO.,LTD.

Address: Unit 1, Room 501, Hongxiang Building, No.258 Hubin Nan Road, Siming District, Xiamen, China  
+1 (334) 336-0888

**MTOM Statement**

D20S is a quadrotor drone. The MTOM of D20S is 144 g, including the propellers, the Flight Battery, which is compliant with C0 requirements.

Users must follow the instructions below to comply with the MTOM C0 requirements. Otherwise, the drone cannot be used as a C0 aircraft:

1. DO NOT add any payload to the aircraft except the items listed in the List of Items including qualified accessories section.
2. DO NOT use any non-qualified replacement parts, such as flight batteries or propellers, etc.
3. DO NOT retrofit the aircraft.

## 4.4 Compliance Information &gt;&gt;

**List of Items including qualified accessories**

1. D20S Propellers (0.95g each propeller)
2. D20S Flight Battery (approx. 34.5g)

**List of Spare and Replacement Parts**

1. D20S Propellers (0.95g each propeller)
2. D20S Flight Battery (approx. 34.5g)

**List of Safe Guards**

Below is the list of the mechanical safeguards and operation safeguards for D20S.

1. Emergency Stop function can be performed to stop the motors in case of an emergency. Refer to the Emergency Stop section for details.
2. The Optical Flow Positioning. Refer to the Optical Flow Positioning section for details.
3. Prevent the drone from flying in restricted airspace. Refer to the Flight Environment Requirements section for details.

