

TEST REPORT

Product Name : Face Recognition Terminal
Model Number : Edge Point
FCC ID : 2AJ2B-EDGEPOINT

Prepared for : Telepower Communication Co., Ltd.
Address : 5 Bld, Zone A, Hantian Technology Town No.17 ShenHai
RD, Nanhai District, Foshan, China

Prepared by : EMTEK (SHENZHEN) CO., LTD.
Address : Building 69, Majialong Industry Zone, Nanshan District,
Shenzhen, Guangdong, China

Tel: (0755) 26954280
Fax: (0755) 26954282

Report Number : ENS2206230216W00205R
Date(s) of Tests : June 23, 2022 to July 19, 2022
Date of issue : July 21, 2022

TABLE OF CONTENTS

1. TEST RESULT CERTIFICATION	3
2. EUT DESCRIPTION	4
3. SUMMARY OF TEST RESULT	6
4. TEST METHODOLOGY	7
4.1 General Description Of Applied Standards	7
4.2 Measurement Equipment Used.....	7
4.3 Description Of Test Modes	8
4.4 Test Software.....	9
5. FACILITIES AND ACCREDITATIONS	10
5.1 Facilities.....	10
5.2 Equipment.....	10
5.3 Laboratory Accreditations And Listings	10
6. SETUP OF EQUIPMENT UNDER TEST	11
6.1 Setup Configuration Of Eut.....	11
6.2 Calibration Of Dfs Detection Threshold Level:	11
6.3 Support Equipment.....	12
7. DYNAMIC FREQUENCY SELECTION REQUIREMENTS	13
7.1 Applicable Standard	13
7.2 Conformance Limit	13
7.3 Test Configuration	13
7.4 Test Parameters Of DFS Test Signal.....	14
7.5 Transmitter Output Power	15
7.6 Operation Modes And Requirement Test Items	16
7.7 Test Procedure	16
8. TEST RESULT	17
8.1 Detailed Test Results	17
8.2 Radar Waveform	18
8.3 In-Service Monitoring	20
8.4 Non-Occupancy Period	23

1. TEST RESULT CERTIFICATION

Applicant : Telepower Communication Co., Ltd.
 Address : 5 Bld, Zone A, Hantian Technology Town No.17 ShenHai RD, Nanhai District, Foshan, China
 Manufacturer : Telepower Communication Co., Ltd.
 Address : 5 Bld, Zone A, Hantian Technology Town No.17 ShenHai RD, Nanhai District, Foshan, China
 EUT : Face Recognition Terminal
 Model Name : Edge Point
 Trademark : **oosto**

Measurement Procedure Used:

APPLICABLE STANDARDS	
STANDARD	TEST RESULT
FCC 47 CFR Part 15, Subpart E	PASS
IC RSS-247 Issue 2(02-2017)	PASS

The above equipment was tested by EMTEK (SHENZHEN) CO., LTD. The test data, data evaluation, test procedures, and equipment configurations shown in this report were made in accordance with the procedures given in ANSI C63.10 (2013) and the energy emitted by the sample EUT tested as described in this report is in compliance with the requirements of FCC Rules Part 15.407 and IC RSS-247 Issue 2.

The test results of this report relate only to the tested sample identified in this report.

Date of Test : June 23, 2022 to July 19, 2022

Prepared by : 
 Una Yu /Editor

Reviewer : 
 Joe Xia /Supervisor

Approve & Authorized Signer : 
 Lisa Wang/Manager



2. EUT DESCRIPTION

Characteristics	Description
Product:	Face Recognition Terminal
Model Number:	Edge Point
Sample Number:	2#
Wifi Type:	Wifi 5G with 5150MHz-5250MHz Band Wifi 5G with 5250MHz-5350MHz Band Wifi 5G with 5470MHz-5725MHz Band Wifi 5G with 5725MHz-5850MHz Band
WLAN Supported:	802.11a/n/ac
Data Rate :	802.11a: 54/48/36/24/18/12/9/6Mbps 802.11n: MCS0-MCS15 802.11ac: MCS0-MCS9
Modulation:	OFDM with BPSK/QPSK/16QAM/64QAM for 802.11a/n OFDM with BPSK/QPSK/16QAM/64QAM/256QAM for 802.11ac
Frequency Range:	UNII-1: 5150MHz-5250MHz Band 5180-5240MHz for 802.11a/n(HT20)/ac(VHT20); 5190-5230MHz for 802.11n(HT40)/ac(VHT40); 5210MHz for 802.11ac(VHT80);
	UNII-2A: 5250MHz-5350MHz Band 5260-5320MHz for 802.11a/n(HT20)/ac(VHT20); 5270-5310MHz for 802.11n(HT40)/ac(VHT40); 5290MHz for 802.11ac(VHT80);
	UNII-2C: 5470MHz-5725MHz Band 5500-5700MHz for 802.11a/n(HT20)/ac(VHT20); 5510-5670MHz for 802.11n(HT40)/ac(VHT40); 5530MHz for 802.11ac(VHT80);
	UNII-3 with 5725MHz-5850MHz Band 5745-5825MHz for 802.11a/n(HT20)/ac(VHT20); 5755-5795MHz for 802.11n(HT40)/ac(VHT40); 5775MHz for 802.11ac(VHT80);
TPC Function:	Not Applicable
Antenna Type:	FPC Antenna
Antenna Gain:	ANT 1: 4.60 dBi
Transmit Power:	UNII-1 Band: 17.75 dBm UNII-2A Band: 17.42 dBm UNII-2C Band: 16.75 dBm UNII-3 Band: 16.30 dBm

Power Supply:	DC12V from adapter
Adapter:	Model: BI24-120200-AdU Input: AC100-240, 50Hz/60Hz,0.8A Output: DC12V,2.0A
Date of Received:	June 23, 2022
Temperature Range:	-10°C ~ +45°C
Transmit Power:	5150MHz-5250MHz : 17.75 dBm 5250MHz-5350MHz : 17.42 dBm 5470MHz-5725MHz : 16.75 dBm 5725MHz-5850MHz : 16.30 dBm
Power Supply :	Input: AC 100-240V~2.5A 50/60HZ
Temperature Range:	-10°C ~ +45°C

Note: for more details, please refer to the User's manual of the EUT.

3. SUMMARY OF TEST RESULT

FCC Part Clause	IC Part Clause	Test Parameter	Remarks	Pass/Fail
15.407(h)	RSS-247 6.3	DFS Detection Threshold	N/A	N/A
		Channel Availability Check Time	N/A	N/A
		Channel Move Time	Applicable	Pass
		Channel Closing Transmission Time	Applicable	Pass
		Non- Occupancy Period	N/A	N/A
		Uniform Spreading	N/A	N/A
		U-NII Detection Bandwidth	N/A	N/A



4. TEST METHODOLOGY

4.1 GENERAL DESCRIPTION OF APPLIED STANDARDS

According to its specifications, the EUT must comply with the requirements of the following standards:

FCC 06-96

FCC 47 CFR Parts 15, Subpart E

FCC KDB 905462 D02 UNII DFS Compliance Procedures New Rules v02

IC RSS-247 Issue 2(02-2017)

4.2 MEASUREMENT EQUIPMENT USED

Equipment	Manufacturer	Model No.	Serial No.	Last Cal.	Cal. Interval
Wireless Connectivity Tester	R&S	CMW270	102543	Aug. 27, 2021	1Year
Automatic Control Unit	Tonscend	JS0806-2	2118060480	Nov. 18, 2021	1Year
Signal Analyzer	KEYSIGHT	N9010B	MY60242456	Jan. 21, 2022	1Year
Analog Signal Generator	KEYSIGHT	N5173B	MY61252625	Oct. 29, 2021	1Year
UP/DOWN-Converter	R&S	CMW-Z800A	100274	Sep. 14, 2021	1Year
Vector Signal Generator	KEYSIGHT	N5182B	MY61252674	Oct. 28, 2021	1Year
Frequency Extender	KEYSIGHT	N5182BX07	MY59362541	Nov. 23, 2021	1Year
Temperature&Humidity test chamber	ESPEC	EL-02KA	12107166	Jul. 02, 2022	1 Year

4.3 DESCRIPTION OF TEST MODES

The EUT has been tested under its typical operating condition.

The EUT configuration for testing is installed on RF field strength measurement to meet the Commissions requirement and operating in a manner which intends to maximize its emission characteristics in a continuous normal application.

The Transmitter was operated in the normal operating mode. The TX frequency was fixed which was for the purpose of the measurements.

Test of channel included the lowest and middle and highest frequency to perform the test, then record on this report.

Pre-defined engineering program for regulatory testing used to control the EUT for staying in continuous transmitting and receiving mode is programmed.

Wifi 5G with U-NII -2A

Frequency and Channel list 802.11a, 802.11n (HT20), 802.11ac (VHT20):

Channel	Frequency (MHz)	Channel	Frequency (MHz)	Channel	Frequency (MHz)
52	5260	60	5300		
56	5280	64	5320		

Frequency and Channel list for 802.11n (HT40), 802.11ac (VHT40):

Channel	Frequency (MHz)	Channel	Frequency (MHz)	Channel	Frequency (MHz)
54	5270				
62	5310				

Frequency and Channel list for 802.11ac (VHT80):

Channel	Frequency (MHz)	Channel	Frequency (MHz)	Channel	Frequency (MHz)
58	5290				

Test Frequency and Channel for 802.11a, 802.11n (HT20), 802.11ac (VHT20):

Lowest Frequency		Middle Frequency		Highest Frequency	
Channel	Frequency (MHz)	Channel	Frequency (MHz)	Channel	Frequency (MHz)
52	5260	56	5280	64	5320

Test Frequency and channel for 802.11n (HT40), 802.11ac (VHT40):

Lowest Frequency		Middle Frequency		Highest Frequency	
Channel	Frequency (MHz)	Channel	Frequency (MHz)	Channel	Frequency (MHz)
54	5270	N/A	N/A	62	5310

Test Frequency and channel for 802.11ac (VHT80):

Lowest Frequency		Middle Frequency		Highest Frequency	
Channel	Frequency (MHz)	Channel	Frequency (MHz)	Channel	Frequency (MHz)
58	5290				

Wifi 5G with U-NII -2C

Frequency and Channel list for 802.11a, 802.11n (HT20), 802.11ac (VHT20):

Channel	Frequency (MHz)	Channel	Frequency (MHz)	Channel	Frequency (MHz)
100	5500	116	5580	132	5660
104	5520	120	5600	136	5680
108	5540	124	5620	140	5700
112	5560	128	5640		

Frequency and Channel list for 802.11n (HT40), 802.11ac (VHT40):

Channel	Frequency (MHz)	Channel	Frequency (MHz)	Channel	Frequency (MHz)
102	5510	118	5590	134	5670
110	5550	126	5630		

Frequency and Channel list for 802.11ac (VHT80):

Channel	Frequency (MHz)	Channel	Frequency (MHz)	Channel	Frequency (MHz)
106	5530	122	5610		

Test Frequency and Channel for 802.11a, 802.11n (HT20), 802.11ac (VHT20):

Lowest Frequency		Middle Frequency		Highest Frequency	
Channel	Frequency (MHz)	Channel	Frequency (MHz)	Channel	Frequency (MHz)
100	5500	120	5600	140	5700

Test Frequency and channel for 802.11n (HT40), 802.11ac (VHT40):

Lowest Frequency		Middle Frequency		Highest Frequency	
Channel	Frequency (MHz)	Channel	Frequency (MHz)	Channel	Frequency (MHz)
102	5510			134	5670

Test Frequency and channel for 802.11ac (VHT80):

Lowest Frequency		Middle Frequency		Highest Frequency	
Channel	Frequency (MHz)	Channel	Frequency (MHz)	Channel	Frequency (MHz)
106	5530				

4.4 TEST SOFTWARE

Item	Software
RF conducted:	ETSI Certification of Regulations Test Solution(V1.04.01)
	N7607B Signal Studio for DFS Radar Profiles

5. FACILITIES AND ACCREDITATIONS

5.1 FACILITIES

All measurement facilities used to collect the measurement data are located at

Building 69, Majialong Industry Zone District, Nanshan District, Shenzhen, China

The sites are constructed in conformance with the requirements of ANSI C63.7, ANSI C63.4 and CISPR Publication 22.

5.2 EQUIPMENT

Radiated emissions are measured with one or more of the following types of linearly polarized antennas: tuned dipole, biconical, log periodic, bi-log, and/or ridged waveguide, horn. Spectrum analyzers with preselectors and quasi-peak detectors are used to perform radiated measurements.

Conducted emissions are measured with Line Impedance Stabilization Networks and EMI Test Receivers.

Calibrated wideband preamplifiers, coaxial cables, and coaxial attenuators are also used for making measurements.

All receiving equipment conforms to CISPR Publication 16-1, "Radio Interference Measuring Apparatus and Measurement Methods."

5.3 LABORATORY ACCREDITATIONS AND LISTINGS

Site Description	
EMC Lab.	<p>Accredited by CNAS The Certificate Registration Number is L2291. The Laboratory has been assessed and proved to be in compliance with CNAS-CL01 (identical to ISO/IEC 17025:2017)</p> <p>Accredited by FCC Designation Number: CN1204 Test Firm Registration Number: 882943</p> <p>Accredited by A2LA The Certificate Number is 4321.01.</p> <p>Accredited by Industry Canada The Conformity Assessment Body Identifier is CN0008</p>
Name of Firm	: EMTEK (SHENZHEN) CO., LTD.
Site Location	: Building 69, Majialong Industry Zone, Nanshan District, Shenzhen, Guangdong, China

6. SETUP OF EQUIPMENT UNDER TEST

6.1 SETUP CONFIGURATION OF EUT

Master Modes

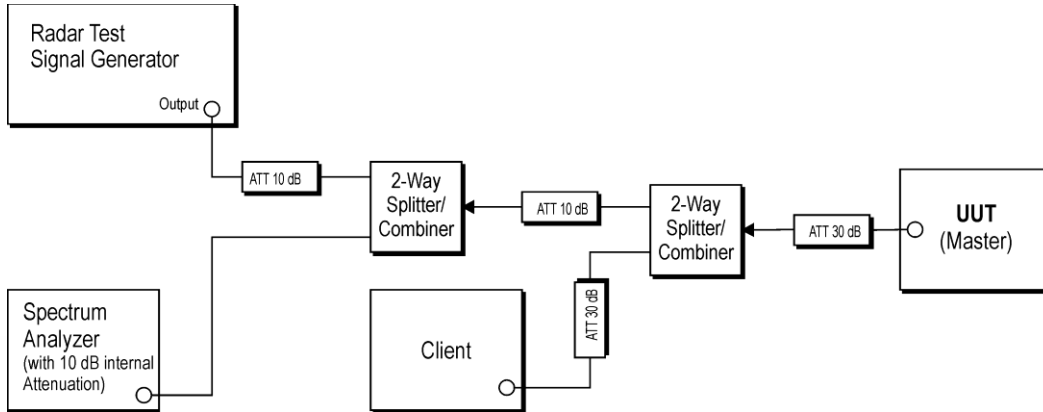

Slave Mode

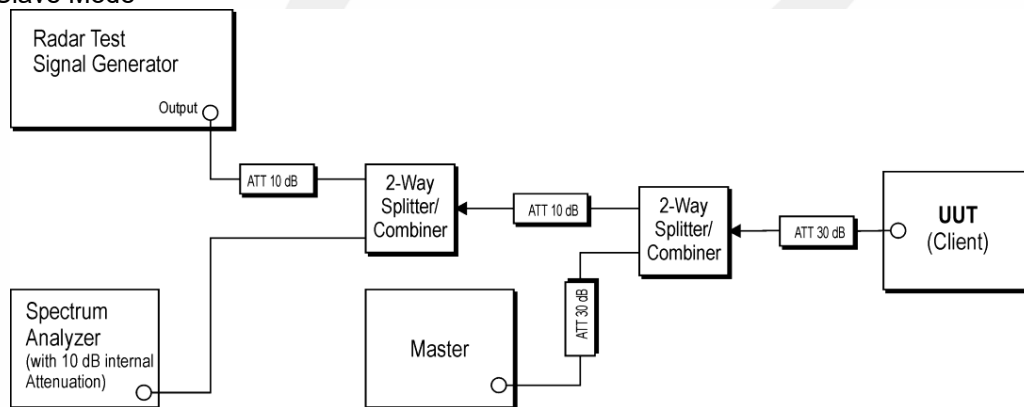

6.2 CALIBRATION OF DFS DETECTION THRESHOLD LEVEL:

A 50 ohm load is connected in place of the spectrum analyzer, and the spectrum analyzer is connected in place of the master device and the signal generator is set to CW mode. The amplitude of the signal generator is adjusted to yield a level of -62 dBm as measured on the spectrum analyzer.

Without changing any of the instrument settings, the spectrum analyzer is reconnected to the Common port of the Spectrum Analyzer Combiner/Divider. Measure the amplitude and calculate the difference from -62 dBm. Adjust the Reference Level Offset of the spectrum analyzer to this difference.

The spectrum analyzer displays the level of the signal generator as received at the antenna ports of the Master Device. The interference detection threshold may be varied from the calibrated value of -62 dBm and the spectrum analyzer will still indicate the level as received by the Master Device.

Set the signal generator to produce a radar waveform, trigger a burst manually and measure the level on the spectrum analyzer. Readjust the amplitude of the signal generator as required so that the peak level of the waveform is at a displayed level equal to the required or desired interference detection threshold.

Separate signal generator amplitude settings are determined as required for each radar type.

6.3 SUPPORT EQUIPMENT

Item	Equipment	Mfr/Brand	Model/Type No.	Series No.	FCC ID/IC
1.	Wireless Access Point	Cisco	AIR-CAP3702E-A-K9	FTX182276QD	FCC ID: LDK102087 IC:2461B-102087
<p>Note: Software for transferring data between master and slave devices is TFGEN-1.00 (transmission rate >80%)</p>					

Notes:

1. All the equipment/cables were placed in the worst-case configuration to maximize the emission during the test.
2. Grounding was established in accordance with the manufacturer's requirements and conditions for the intended use.



7. DYNAMIC FREQUENCY SELECTION REQUIREMENTS

7.1 APPLICABLE STANDARD

According to 15.407(h) and RSS-247 6.3

7.2 CONFORMANCE LIMIT

The dynamic frequency selection requirement

Parameter	Value
Non-occupancy period	Minimum 30 minutes
Channel Availability Check Time	60 seconds
Channel Move Time	10 seconds See Note 1.
Channel Closing Transmission Time	200 milliseconds + an aggregate of 60 milliseconds over remaining 10 second periods. See Notes 1 and 2.
U-NII Detection Bandwidth	Minimum 100% of the U-NII 99% transmission power bandwidth. See Note 3.

Note 1: Channel Move Time and the Channel Closing Transmission Time should be performed with Radar Type 0. The measurement timing begins at the end of the Radar Type 0 burst.

Note 2: The Channel Closing Transmission Time is comprised of 200 milliseconds starting at the beginning of the Channel Move Time plus any additional intermittent control signals required to facilitate a Channel move (an aggregate of 60 milliseconds) during the remainder of the 10 second period. The aggregate duration of control signals will not count quiet periods in between transmissions.

Note 3: During the U-NII Detection Bandwidth detection test, radar type 0 should be used. For each frequency step the minimum percentage of detection is 90 percent. Measurements are performed with no data traffic.

The following table lists the DFS The detection threshold values

Maximum Transmit Power	Value (See Notes 1, 2, and 3)
EIRP \geq 200 milliwatt	-64 dBm
EIRP < 200 milliwatt and power spectral density < 10 dBm/MHz	-62 dBm
EIRP < 200 milliwatt that do not meet the power spectral density requirement	-64 dBm

Note 1: This is the level at the input of the receiver assuming a 0 dBi receive antenna.

Note 2: Throughout these test procedures an additional 1 dB has been added to the amplitude of the test transmission waveforms to account for variations in measurement equipment. This will ensure that the test signal is at or above the detection threshold level to trigger a DFS response.

Note3: EIRP is based on the highest antenna gain. For MIMO devices refer to KDB Publication 662911 D01.

7.3 TEST CONFIGURATION

Conducted measurements shall be used for DFS test

7.4 TEST PARAMETERS OF DFS TEST SIGNAL

The following table lists the parameters of radar test signals

Short Pulse Radar Test Waveforms

Radar Type	Pulse Width (μsec)	PRI (μsec)	Number of Pulses	Minimum Percentage of Successful Detection	Minimum Number of Trials
0	1	1428	18	See Note 1	See Note 1
1	1	Test A: 15 unique PRI values randomly selected from the list of 23 PRI values in Table 5a	Roundup $\left\{ \begin{matrix} \left(\frac{1}{360} \right) \cdot \\ \left(\frac{19 \cdot 10^6}{PRI_{\mu sec}} \right) \end{matrix} \right\}$	60%	30
		Test B: 15 unique PRI values randomly selected within the range of 518-3066 μsec, with a minimum increment of 1 μsec, excluding PRI values selected in Test A			
2	1-5	150-230	23-29	60%	30
3	6-10	200-500	16-18	60%	30
4	11-20	200-500	12-16	60%	30
Aggregate (Radar Types 1-4)				80%	120
Note 1: Short Pulse Radar Type 0 should be used for the detection bandwidth test, channel move time, and channel closing time tests.					

Long Pulse Radar Test Waveform

Radar Type	Pulse Width (μsec)	Chirp Width (MHz)	PRI (μsec)	Number of Pulses per Burst	Number of Bursts	Minimum Percentage of Successful Detection	Minimum Number of Trials
5	50-100	5-20	1000-2000	1-3	8-20	80%	30

Frequency Hopping Radar Test Waveform

Radar Type	Pulse Width (μsec)	PRI (μsec)	Pulses per Hop	Hopping Rate (kHz)	Hopping Sequence Length (msec)	Minimum Percentage of Successful Detection	Minimum Number of Trials
6	1	333	9	0.333	300	70%	30

7.5 TRANSMITTER OUTPUT POWER

Test Mode	Antenna	Frequency[MHz]	Channel Power[dBm]	Duty Cycle [%]	DC Factor [dBm]	Result [dBm]	Limit [dBm]	Gain [dBi]	EIRP [dBm]	EIRP Limit [dBm]	Verdict
11A	Ant1	5260	12.47	98.10	0.08	12.55	≤23.98	4.60	17.15	≤30.00	PASS
		5300	11.83	98.10	0.08	11.91	≤23.98	4.60	16.51	≤30.00	PASS
		5320	12.06	98.10	0.08	12.14	≤23.98	4.60	16.74	≤30.00	PASS
		5500	12.07	98.10	0.08	12.15	≤23.98	4.60	16.75	≤30.00	PASS
		5580	10.89	98.57	0.06	10.95	≤23.98	4.60	15.55	≤30.00	PASS
11N20SI SO	Ant1	5700	10.36	98.10	0.08	10.44	≤23.98	4.60	15.04	≤30.00	PASS
		5260	12.65	97.96	0.09	12.74	≤23.98	4.60	17.34	≤30.00	PASS
		5300	11.90	97.96	0.09	11.99	≤23.98	4.60	16.59	≤30.00	PASS
		5320	12.09	97.96	0.09	12.18	≤23.98	4.60	16.78	≤30.00	PASS
		5500	12.01	98.47	0.07	12.08	≤23.98	4.60	16.68	≤30.00	PASS
11N40SI SO	Ant1	5580	10.84	97.96	0.09	10.93	≤23.98	4.60	15.53	≤30.00	PASS
		5700	10.15	97.96	0.09	10.24	≤23.98	4.60	14.84	≤30.00	PASS
		5270	10.76	95.96	0.18	10.94	≤23.98	4.60	15.54	≤30.00	PASS
		5310	10.16	95.92	0.18	10.34	≤23.98	4.60	14.94	≤30.00	PASS
		5510	9.84	95.92	0.18	10.02	≤23.98	4.60	14.62	≤30.00	PASS
11AC20S ISO	Ant1	5550	9.60	95.92	0.18	9.78	≤23.98	4.60	14.38	≤30.00	PASS
		5670	8.06	95.96	0.18	8.24	≤23.98	4.60	12.84	≤30.00	PASS
		5260	12.73	97.97	0.09	12.82	≤23.98	4.60	17.42	≤30.00	PASS
		5300	11.95	97.97	0.09	12.04	≤23.98	4.60	16.64	≤30.00	PASS
		5320	12.14	97.97	0.09	12.23	≤23.98	4.60	16.83	≤30.00	PASS
11AC40S ISO	Ant1	5500	12.08	98.48	0.07	12.15	≤23.98	4.60	16.75	≤30.00	PASS
		5580	11.00	97.97	0.09	11.09	≤23.98	4.60	15.69	≤30.00	PASS
		5700	10.31	98.48	0.07	10.38	≤23.98	4.60	14.98	≤30.00	PASS
		5270	10.87	95.96	0.18	11.05	≤23.98	4.60	15.65	≤30.00	PASS
		5310	10.30	96.94	0.13	10.43	≤23.98	4.60	15.03	≤30.00	PASS
11AC80S ISO	Ant1	5510	9.93	95.96	0.18	10.11	≤23.98	4.60	14.71	≤30.00	PASS
		5550	9.71	95.96	0.18	9.89	≤23.98	4.60	14.49	≤30.00	PASS
		5670	8.07	95.96	0.18	8.25	≤23.98	4.60	12.85	≤30.00	PASS
		5290	9.65	92.00	0.36	10.01	≤23.98	4.60	14.61	≤30.00	PASS
		5530	8.74	92.00	0.36	9.10	≤23.98	4.60	13.70	≤30.00	PASS
	Ant1	5610	7.92	92.00	0.36	8.28	≤23.98	4.60	12.88	≤30.00	PASS

7.6 OPERATION MODES AND REQUIREMENT TEST ITEMS

The manufacture shall state whether the EUT is capable of operating as a Master or a Slave modes,if the EUT is capable of operating in more than one operational mode then every operating mode shall be assessed separately.

Applicability of DFS Requirements Prior to Use of a Channel

Requirement	Operational Mode		
	Master	Client Without Radar Detection	Client With Radar Detection
Non-Occupancy Period	Yes	Not required	Yes
DFS Detection Threshold	Yes	Not required	Yes
Channel Availability Check Time	Yes	Not required	Not required
Uniform Spreading	Yes	Not required	Not required
U-NII Detection Bandwidth	Yes	Not required	Yes

Applicability of DFS requirements during normal operation

Requirement	Operational Mode		
	Master	Client Without Radar Detection	Client With Radar Detection
DFS Detection Threshold	Yes	Not required	Yes
Channel Closing Transmission Time	Yes	Yes	Yes
Channel Move Time	Yes	Yes	Yes
U-NII Detection Bandwidth	Yes	Not required	Yes

7.7 TEST PROCEDURE

According to KDB 905462 D02v02 Section 7.

8. TEST RESULT

8.1 DETAILED TEST RESULTS

MODES	Test Parameter	Remark	Verdict
<input type="checkbox"/> Master	DFS Detection Threshold	N/A	N/A
	Channel Availability Check Time	N/A	N/A
	Channel Move Time	N/A	N/A
	Channel Closing Transmission Time	N/A	N/A
	Non-Occupancy Period	N/A	N/A
	Uniform Spreading	N/A	N/A
	U-NII Detection Bandwidth	N/A	N/A
<input checked="" type="checkbox"/> Slave	Radar Detection Threshold	N/A	N/A
	Channel Move Time	Applicable	PASS
	Channel Closing Transmission Time	Applicable	PASS
	Non-Occupancy Period	N/A	N/A
	U-NII Detection Bandwidth	N/A	N/A

8.2 RADAR WAVEFORM

Calibration:

Maximum Transmit Power is be less than 200 milliwatt and power spectral density <10 dBm/MHz in this report, so detection threshold level is -62dBm.

The 801.11a/n/ac have been tested, and the worst result have been recorded in the below page.



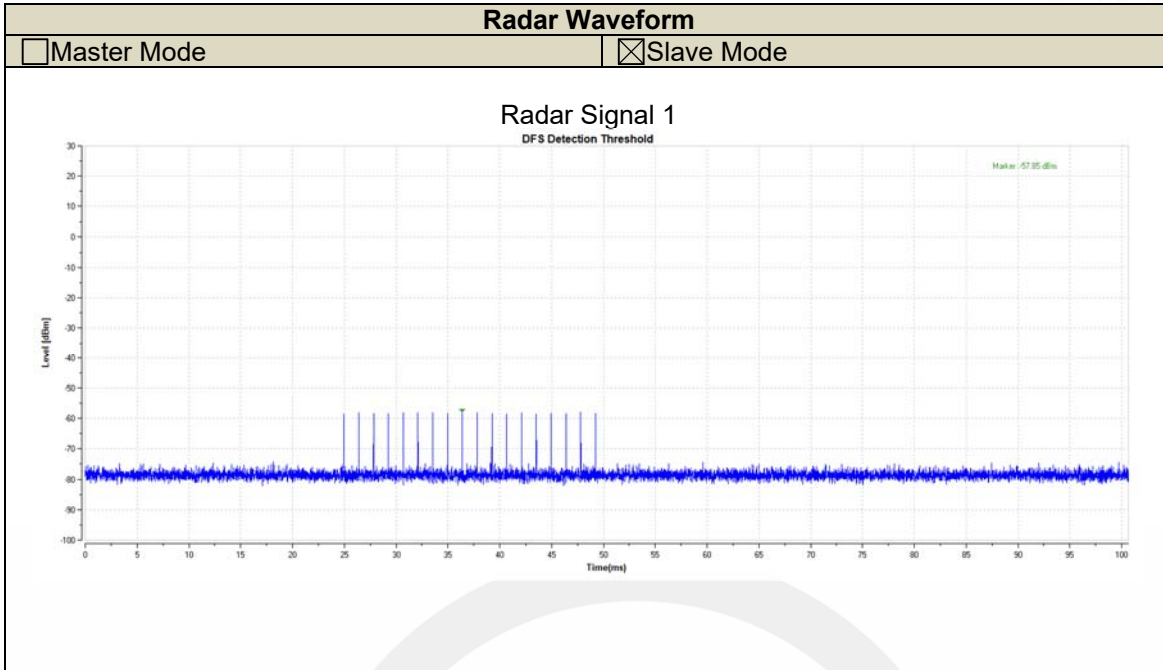

8.3 IN-SERVICE MONITORING

U-NII-Band II-A

Radar test signal type 0					Detection(Y/N)
Trial ID	Pulse Width(us)	PRI(us)	Number of Pulses	Waveform Length(us)	
0	1.0	1428.0	18	25704.0	Y
1	1.0	1428.0	18	25704.0	Y
2	1.0	1428.0	18	25704.0	Y
3	1.0	1428.0	18	25704.0	Y
4	1.0	1428.0	18	25704.0	Y
5	1.0	1428.0	18	25704.0	Y
6	1.0	1428.0	18	25704.0	Y
7	1.0	1428.0	18	25704.0	Y
8	1.0	1428.0	18	25704.0	Y
9	1.0	1428.0	18	25704.0	Y
10	1.0	1428.0	18	25704.0	Y
11	1.0	1428.0	18	25704.0	Y
12	1.0	1428.0	18	25704.0	Y
13	1.0	1428.0	18	25704.0	Y
14	1.0	1428.0	18	25704.0	Y
15	1.0	1428.0	18	25704.0	Y
16	1.0	1428.0	18	25704.0	Y
17	1.0	1428.0	18	25704.0	Y
18	1.0	1428.0	18	25704.0	Y
19	1.0	1428.0	18	25704.0	Y
20	1.0	1428.0	18	25704.0	Y
21	1.0	1428.0	18	25704.0	Y
22	1.0	1428.0	18	25704.0	Y
23	1.0	1428.0	18	25704.0	Y
24	1.0	1428.0	18	25704.0	Y
25	1.0	1428.0	18	25704.0	Y
26	1.0	1428.0	18	25704.0	Y
27	1.0	1428.0	18	25704.0	Y
28	1.0	1428.0	18	25704.0	Y
29	1.0	1428.0	18	25704.0	Y
Detection Rate					100%

U-NII-Band II-C

Radar test singal type 0					Detection(Y/N)
Trial ID	Pulse Width(us)	PRI(us)	Number of Pulses	Waveform Length(us)	
0	1.0	1428.0	18	25704.0	Y
1	1.0	1428.0	18	25704.0	Y
2	1.0	1428.0	18	25704.0	Y
3	1.0	1428.0	18	25704.0	Y
4	1.0	1428.0	18	25704.0	Y
5	1.0	1428.0	18	25704.0	Y
6	1.0	1428.0	18	25704.0	Y
7	1.0	1428.0	18	25704.0	Y
8	1.0	1428.0	18	25704.0	Y
9	1.0	1428.0	18	25704.0	Y
10	1.0	1428.0	18	25704.0	Y
11	1.0	1428.0	18	25704.0	Y
12	1.0	1428.0	18	25704.0	Y
13	1.0	1428.0	18	25704.0	Y
14	1.0	1428.0	18	25704.0	Y
15	1.0	1428.0	18	25704.0	Y
16	1.0	1428.0	18	25704.0	Y
17	1.0	1428.0	18	25704.0	Y
18	1.0	1428.0	18	25704.0	N
19	1.0	1428.0	18	25704.0	Y
20	1.0	1428.0	18	25704.0	Y
21	1.0	1428.0	18	25704.0	Y
22	1.0	1428.0	18	25704.0	Y
23	1.0	1428.0	18	25704.0	Y
24	1.0	1428.0	18	25704.0	N
25	1.0	1428.0	18	25704.0	Y
26	1.0	1428.0	18	25704.0	Y
27	1.0	1428.0	18	25704.0	Y
28	1.0	1428.0	18	25704.0	Y
29	1.0	1428.0	18	25704.0	Y
Detection Rate					93%

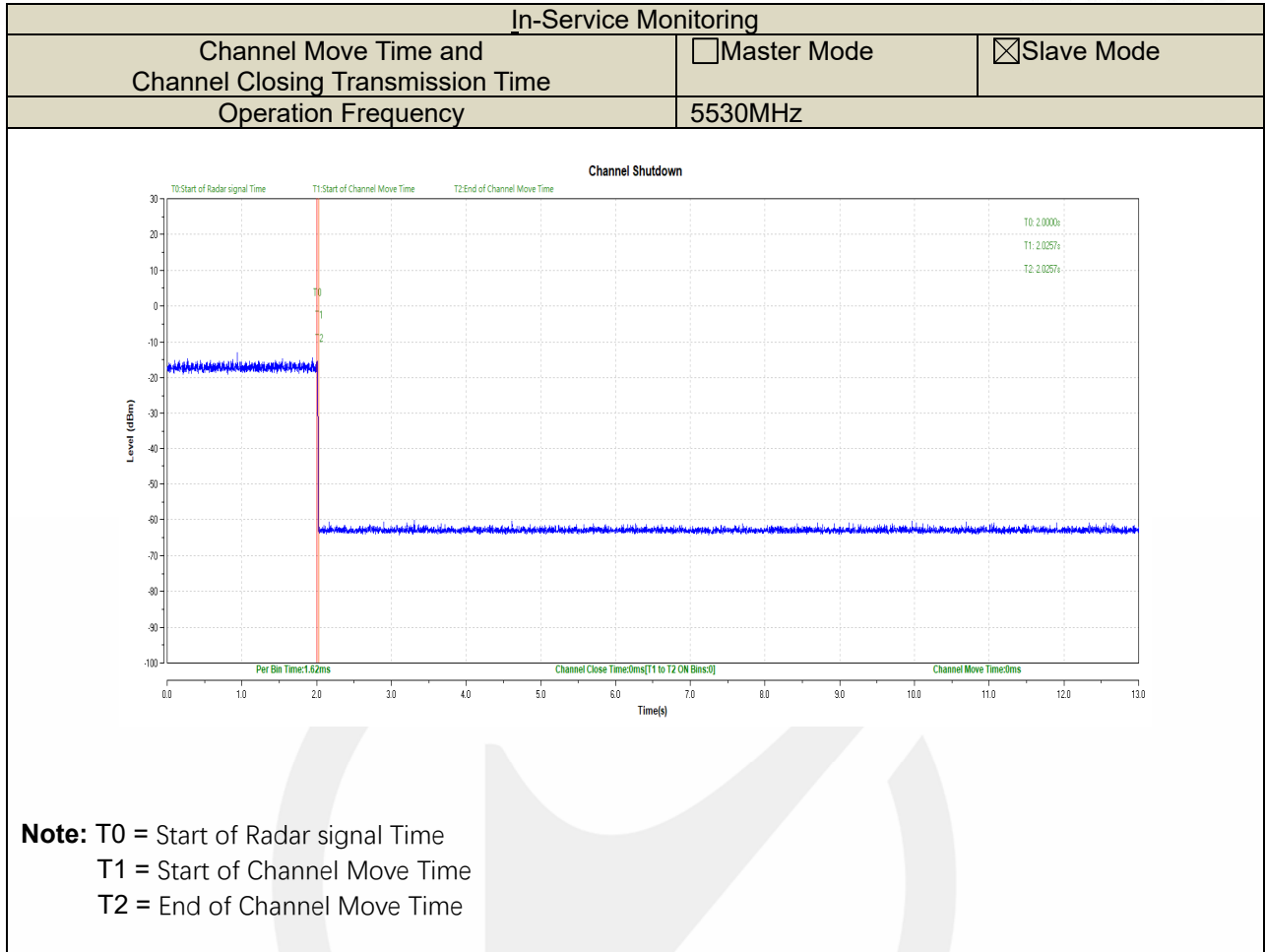

8.4 NON-OCCUPANCY PERIOD

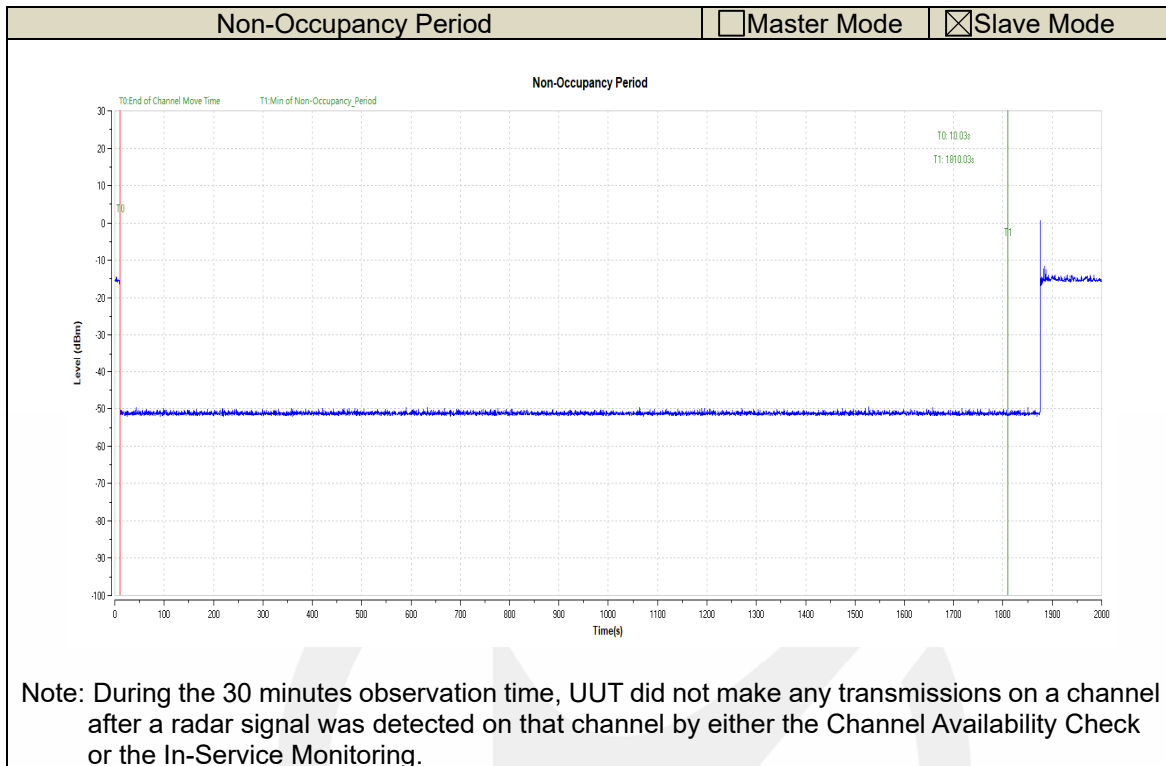

----- END OF REPORT -----