

FCC TEST REPORT
for
iTon Technology Corp.

BW2570-PCIE
Model No.: BW2570-PCIE

Prepared for : iTon Technology Corp.
Address : 7 Floor East, Building C, No. 1006 Shennan Road, Shenzhen
International Innovation Center (Futian Technology Square),
Futian District, Shenzhen, China

Prepared By : Shenzhen Anbotek Compliance Laboratory Limited
Address : 1/F., Building 1, SEC Industrial Park, No.0409 Qianhai Road,
Nanshan District, Shenzhen, Guangdong, China
Tel: (86) 755-26066544
Fax: (86) 755-26014772

Report Number : R011609746Y
Date of Test : Oct. 08~ 17, 2016
Date of Report : Oct. 17, 2016

TABLE OF CONTENT

Description

Page

Test Report

1. GENERAL INFORMATION.....4

 1.1. Description of Device (EUT).....4

 1.2. Auxiliary Equipment Used during Test.....5

 1.3. Description of Test Facility.....6

 1.4. Measurement Uncertainty.....6

2. TEST METHODOLOGY.....7

 2.1. Summary of Test Results.....7

 2.2. Description of Test Modes.....7

 2.3. List of channels:.....8

3. Conducted Emission Test.....9

 3.1. Block Diagram of Test Setup.....9

 3.2. Power Line Conducted Emission Measurement Limits (15.207).....9

 3.3. Configuration of EUT on Measurement.....9

 3.4. Operating Condition of EUT.....9

 3.5. Test Procedure.....10

 3.6. Test equipment.....10

 3.7. Power Line Conducted Emission Measurement Results.....10

4. FCC Part 15.247 Requirements for DSSS & OFDM Modulation..... 15

 4.1 Test Setup.....15

 4.2 6dB Bandwidth.....15

 4.3. Maximum Output Power Test.....29

 4.4. Band Edges Measurement.....37

 4.5. Peak Power Spectral Density.....75

 4.6. Radiated Emissions.....83

5. ANTENNA APPLICATION..... 94

 5.1. Antenna requirement.....94

 5.2. Result.....94

6. PHOTOGRAPH..... 95

 6.1. Photo of Conducted Emission Test.....95

 6.2. Photo of Radiation Emission Test.....95

APPENDIX I (EXTERNAL PHOTOS)..... 97

APPENDIX II (INTERNAL PHOTOS)..... 99

TEST REPORT

Applicant : iTon Technology Corp.
Manufacturer : iTon Technology Corp.
EUT : BW2570-PCIE
Model No. : BW2570-PCIE
Serial No. : N.A.
Trade Mark : N.A.
Rating : DC 3.3V, 680mA

Measurement Procedure Used:
FCC Part15 Subpart C 2016, Paragraph 15.247

The device described above is tested by Shenzhen Anbotek Compliance Laboratory Limited to determine the maximum emission levels emanating from the device and the severe levels of the device can endure and its performance criterion. The measurement results are contained in this test report and Shenzhen Anbotek Compliance Laboratory Limited is assumed full of responsibility for the accuracy and completeness of these measurements. Also, this report shows that the EUT (Equipment Under Test) is technically compliant with the FCC Part 15 Subpart C requirements.

This report applies to above tested sample only and shall not be reproduced in part without written approval of Shenzhen Anbotek Compliance Laboratory Limited.

Date of Test : Oct. 08~ 17, 2016

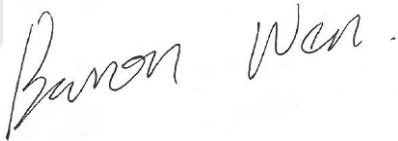
Prepared by : 
(Tested Engineer / Baron Wen)

Reviewer : 
(Project Manager / Amy Ding)

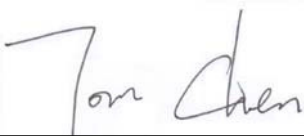
Approved & Authorized Signer : 
(Manager / Tom Chen)

1. GENERAL INFORMATION

1.1. Description of Device (EUT)

EUT : BW2570-PCIE

Model Number : BW2570-PCIE
(Note: During the test, the EUT is inserted into the PC)

Test Power Supply : DC 3.3V from the PC (AC120V/60Hz for PC)

Frequency :

Types of module	Operating Frequency
BT 4.1+EDR	2402-2480MHz
WiFi 2.4G (802.11b/ g/ n(HT20))	2412-2462MHz
WiFi 2.4G (802.11n(HT40))	2422-2452MHz
WiFi 5G (802.11a/ n(HT20)/ ac(HT20))	5180-5240MHz & 5745-5825MHz
WiFi 5G (802.11n(HT40)/ ac(HT40))	5190MHz-MHz & 5755-5795MHz
WiFi 5G (802.11ac(HT80))	5210MHz & 5775MHz

Antenna Spec. : 5 dBi

Modulation : BT EDR: GFSK, $\pi/4$ DQPSK, 8DPSK
BT 4.1: GFSK
WiFi:
802.11a OFDM, 802.11b CCK; 802.11g OFDM, 802.11n MCS;
802.11ac MCS

Applicant : iTon Technology Corp.
Address : 7 Floor East, Building C, No. 1006 Shennan Road, Shenzhen
International Innovation Center (Futian Technology Square), Futian
District, Shenzhen, China

Manufacturer/ Factory : iTon Technology Corp.
Address : Room A1302, Building 4, Tianan Cyber Park, Huangge Rd.,
Longgang, Shenzhen, China

Date of receipt : Sept. 23, 2016

Date of Test : Oct. 08~ 17, 2016

Remark : This report is for WiFi 2.4G.

1.2. Auxiliary Equipment Used during Test

PC	: Manufacturer: DELL M/N: Optiplex 3020 MT S/N: CN-079V51-70163-4AD-089K-A00 Input Rating: AC 100-240V, 50-60Hz 5.4A CE , FCC DOC, CCC
MONITOR	: Manufacturer: DELL M/N: UZ2215Hf S/N: CN-035VN6-72872-45A-A3AB Input Rating: AC 100-240V, 50-60Hz, 1.5A Output Rating: DC 19.5V, 4.62A TUV-GS FCC CE KCC VCCI
KEYBOARD	: Manufacturer: DELL M/N: SK-8120 S/N: CN-0DJ365-71616-49J-0MVR-A00 Input Rating: DC 5V,0.05A CE FCC VCCI KCC TUV-GS Cable: 1.8m, unshielded
MOUSE	: Manufacturer: DELL M/N: MS111-T S/N: CN-0KW2YH-71616-488-1CBJ Input Rating: DC 5V,0.1A Cable: 1.8m, unshielded CE FCC VCCI KCC TUV-GS
Printer	: Manufacturer:Brother M/N: MFC-3360C S/N: N/A CE, FCC:DOC
Power Line	: Non-Shielded, 1.5m
VGA Cable	: Non-Shielded, 1.5m

1.3. Description of Test Facility

The test facility is recognized, certified, or accredited by the following organizations:

FCC-Registration No.: 752021

Shenzhen Anbotek Compliance Laboratory Limited, EMC Laboratory has been registered and fully described in a report filed with the (FCC) Federal Communications Commission. The acceptance letter from the FCC is maintained in our files. Registration 752021, July 06, 2016.

IC-Registration No.: 8058A-1

Shenzhen Anbotek Compliance Laboratory Limited., EMC Laboratory has been registered and fully described in a report filed with the (IC) Industry Canada. The acceptance letter from the IC is maintained in our files. Registration 8058A-1, Jun. 13, 2016.

Test Location

All Emissions tests were performed at Shenzhen Anbotek Compliance Laboratory Limited. at 1/F., Building 1, SEC Industrial Park, No.0409 Qianhai Road, Nanshan District, Shenzhen, Guangdong, China

1.4. Measurement Uncertainty

Radiation Uncertainty : Ur = 4.1 dB (Horizontal)
Ur = 4.3 dB (Vertical)

Conduction Uncertainty : Uc = 3.4dB

2. TEST METHODOLOGY

The tests documented in this report were performed in accordance with ANSI C63.10: 2013 and FCC Part 15, Paragraph 15.247.

2.1. Summary of Test Results

The EUT has been tested according to the following specifications:

Standard	Test Type	Result	Notes
FCC Part 15, Paragraph 15.107, 15.207	Conducted Emission Test	PASS	Complies
FCC Part 15, Paragraph 15.247(b)(1)	Maximum Output Power	PASS	Complies
FCC Part 15, Paragraph 15.247(a)(2)	6dB Bandwidth	PASS	Complies
FCC Part 15, Paragraph 15.247(c)	100kHz Bandwidth of Frequency Band Edges	PASS	Complies
FCC Part 15, Paragraph 15.209(a)(f)	Spurious Emission	PASS	Complies
FCC Part 15, Paragraph 15.247(a)(1)	Frequency Separation	-	N/A
FCC Part 15, Paragraph 15.247(a)(1)(iii)	Number of Hopping Frequency	-	N/A
FCC Part 15, Paragraph 15.247(a)(1)(iii)	Time of Occupancy	-	N/A
FCC Part 15, Paragraph 15.247(c)	Peak Power Density	PASS	Complies

Note: This product is low voltage products. It is using the battery as a power source.

2.2. Description of Test Modes

The EUT has been tested under operating condition.

Software used to control the EUT for staying in continuous transmitting and receiving mode is programmed.

IEEE802.11b: Channel 1(2412MHz), Channel 6(2437MHz) and Channel 11(2462MHz) with 1 Mbps lowest data rate (worst case) are chosen for the final testing.

IEEE802.11g: Channel 1(2412MHz), Channel 6(2437MHz) and Channel 11(2462MHz) with 6 Mbps lowest data rate (the worst case) are chosen for the final testing.

IEEE802.11n (HT20): Channel 1(2412MHz), Channel 6(2437MHz) and Channel 11(2462MHz) with MCS 0 Mbps lowest data rate (the worst case) are chosen for the final testing.

IEEE802.11n (HT40): Channel 3(2422MHz), Channel 6(2437MHz) and Channel 9(2452MHz) with MCS 0 Mbps lowest data rate (the worst case) are chosen for the final testing.

2.3. List of channels:

√ - available

X - tested

Number	Frequency(MHz)		802.11 b/g/n (HT20)	802.11 b/g/n (HT40)
1	2412	√	X	
2	2417	√		
3	2422	√		X
4	2427	√		
5	2432	√		
6	2437	√	X	X
7	2442	√		
8	2447	√		
9	2452	√		X
10	2457	√		
11	2462	√	X	

3. Conducted Emission Test

3.1. Block Diagram of Test Setup

3.1.1. Block diagram of connection between the EUT and simulators

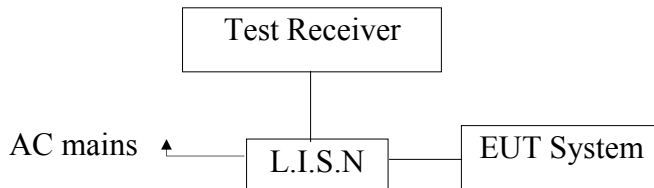

3.2. Power Line Conducted Emission Measurement Limits (15.207)

Frequency MHz	Limits dB(μV)	
	Quasi-peak Level	Average Level
0.15 ~ 0.50	66 ~ 56*	56 ~ 46*
0.50 ~ 5.00	56	46
5.00 ~ 30.00	60	50

- Notes: 1. *Decreasing linearly with logarithm of frequency.
2. The lower limit shall apply at the transition frequencies.

3.3. Configuration of EUT on Measurement

The following equipments are installed on Power Line Conducted Emission Measurement to meet the commission requirement and operating regulations in a manner which tends to maximize its emission characteristics in a normal application.

3.4. Operating Condition of EUT

- 3.4.1. Setup the EUT and simulator as shown as Section 3.1.
- 3.4.2. Turn on the power of all equipment.
- 3.4.3. Let the EUT work in test mode (ON) and measure it.

3.5. Test Procedure

The EUT system is connected to the power mains through a line impedance stabilization network (L.I.S.N.). This provides a 50ohm coupling impedance for the EUT system. Please refer the block diagram of the test setup and photographs. Both sides of AC line are checked to find out the maximum conducted emission. In order to find the maximum emission levels, the relative positions of equipment and all of the interface cables shall be changed according to FCC ANSI C63.10-2013 on Conducted Emission Measurement.

The bandwidth of test receiver (ESCI) set at 9KHz.

The frequency range from 150KHz to 30MHz is checked.

The test results are reported on Section 3.6.

3.6. Test equipment

Item	Equipment	Manufacturer	Model No.	Serial No.	Last Cal.	Cal. Interval
1.	Two-Line V-network	Rohde & Schwarz	ENV216	100055	Apr. 16, 2016	1 Year
2.	EMI Test Receiver	Rohde & Schwarz	ESCI	100627	Apr. 16, 2016	1 Year
3.	RF Switching Unit	Compliance Direction	RSU-M2	38303	Apr. 16, 2016	1 Year

3.7. Power Line Conducted Emission Measurement Results

PASS.

The frequency range from 150KHz to 30 MHz is investigated.

Please refer the following pages.

CONDUCTED EMISSION TEST DATA

Test Site: 1# Shielded Room
 Operating Condition: ON
 Test Specification: AC 120V, 60Hz for PC
 Comment: Live Line
 Tem.:25°C Hum.:50%

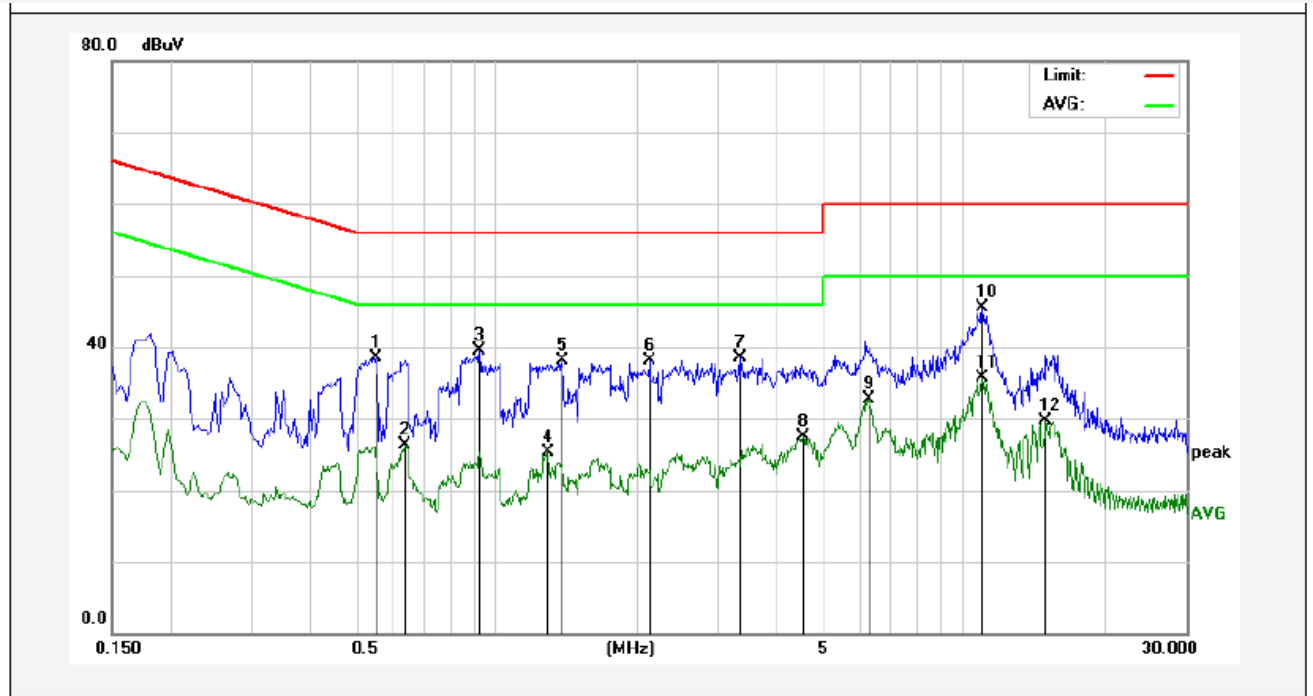

No.	Freq. (MHz)	Reading (dBuV)	Factor (dB)	Result (dBuV)	Limit (dBuV)	Over Limit (dB)	Detector	Remark
1	0.5540	18.60	19.98	38.58	56.00	-17.42	QP	
2	0.6380	6.40	20.01	26.41	46.00	-19.59	AVG	
3	0.9220	19.59	20.10	39.69	56.00	-16.31	QP	
4	1.2900	5.40	20.13	25.53	46.00	-20.47	AVG	
5	1.3820	18.13	20.13	38.26	56.00	-17.74	QP	
6	2.1220	18.04	20.15	38.19	56.00	-17.81	QP	
7	3.3220	18.55	20.16	38.71	56.00	-17.29	QP	
8	4.5380	7.54	20.18	27.72	46.00	-18.28	AVG	
9	6.2460	12.65	20.19	32.84	50.00	-17.16	AVG	
10	10.9819	25.48	20.34	45.82	60.00	-14.18	QP	
11	10.9819	15.73	20.34	36.07	50.00	-13.93	AVG	
12	15.0420	9.70	20.26	29.96	50.00	-20.04	AVG	

CONDUCTED EMISSION TEST DATA

Test Site: 1# Shielded Room
 Operating Condition: ON
 Test Specification: AC 120V, 60Hz for PC
 Comment: Neutral Line
 Tem.:25°C Hum.:50%

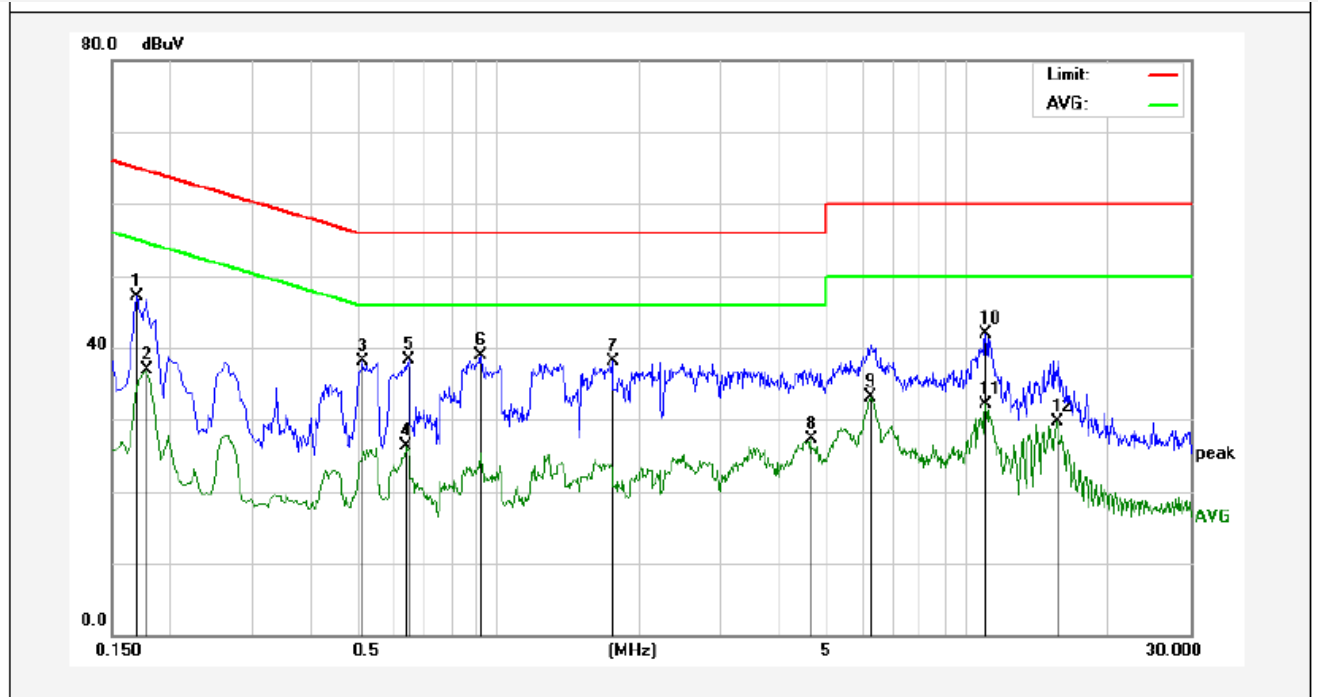

No.	Freq. (MHz)	Reading (dBuV)	Factor (dB)	Result (dBuV)	Limit (dBuV)	Over Limit (dB)	Detector	Remark
1	0.1700	27.11	19.90	47.01	64.96	-17.95	QP	
2	0.1780	16.92	19.90	36.82	54.57	-17.75	AVG	
3	0.5140	18.02	19.98	38.00	56.00	-18.00	QP	
4	0.6380	6.29	19.98	26.27	46.00	-19.73	AVG	
5	0.6460	18.31	19.99	38.30	56.00	-17.70	QP	
6	0.9220	18.81	20.10	38.91	56.00	-17.09	QP	
7	1.7450	18.08	20.13	38.21	56.00	-17.79	QP	
8	4.6500	7.27	20.18	27.45	46.00	-18.55	AVG	
9	6.2340	13.09	20.23	33.32	50.00	-16.68	AVG	
10	10.9740	21.94	20.34	42.28	60.00	-17.72	QP	
11	10.9740	12.19	20.34	32.53	50.00	-17.47	AVG	
12	15.5260	9.79	20.26	30.05	50.00	-19.95	AVG	

CONDUCTED EMISSION TEST DATA

Test Site: 1# Shielded Room
 Operating Condition: ON
 Test Specification: AC 240V, 60Hz for PC
 Comment: Live Line
 Tem.:25°C Hum.:50%

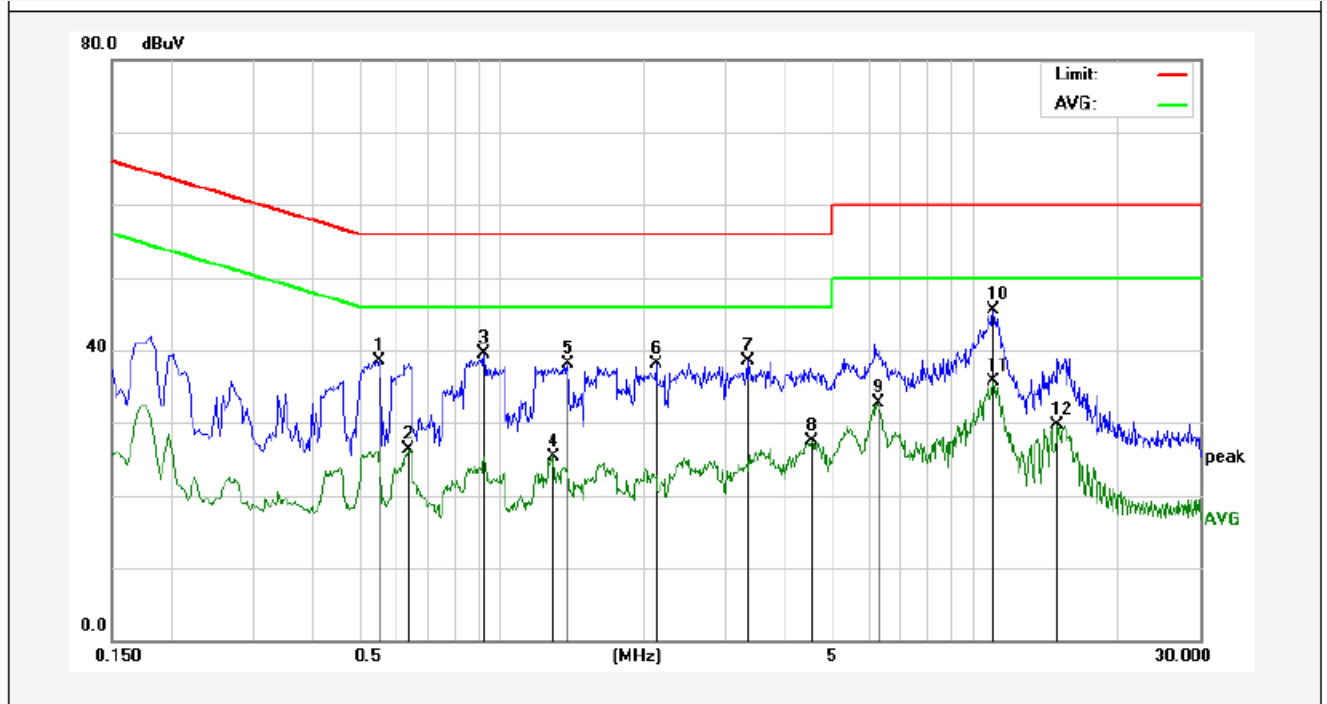

No.	Freq. (MHz)	Reading (dBuV)	Factor (dB)	Result (dBuV)	Limit (dBuV)	Over Limit (dB)	Detector	Remark
1	0.5540	18.60	19.90	38.50	56.00	-17.50	QP	
2	0.6380	6.40	20.00	26.40	46.00	-19.60	AVG	
3	0.9220	19.59	19.89	39.48	56.00	-16.52	QP	
4	1.2900	5.40	20.12	25.52	46.00	-20.48	AVG	
5	1.3820	18.13	20.12	38.25	56.00	-17.75	QP	
6	2.1220	18.04	20.13	38.17	56.00	-17.83	QP	
7	3.3220	18.55	20.15	38.70	56.00	-17.30	QP	
8	4.5380	7.54	20.18	27.72	46.00	-18.28	AVG	
9	6.2460	12.65	20.20	32.85	50.00	-17.15	AVG	
10	10.9819	25.48	20.34	45.82	60.00	-14.18	QP	
11	10.9819	15.73	20.34	36.07	50.00	-13.93	AVG	
12	15.0420	9.70	20.26	29.96	50.00	-20.04	AVG	

CONDUCTED EMISSION TEST DATA

Test Site: 1# Shielded Room
 Operating Condition: ON
 Test Specification: AC 240V, 60Hz for PC
 Comment: Neutral Line
 Tem.:25°C Hum.:50%

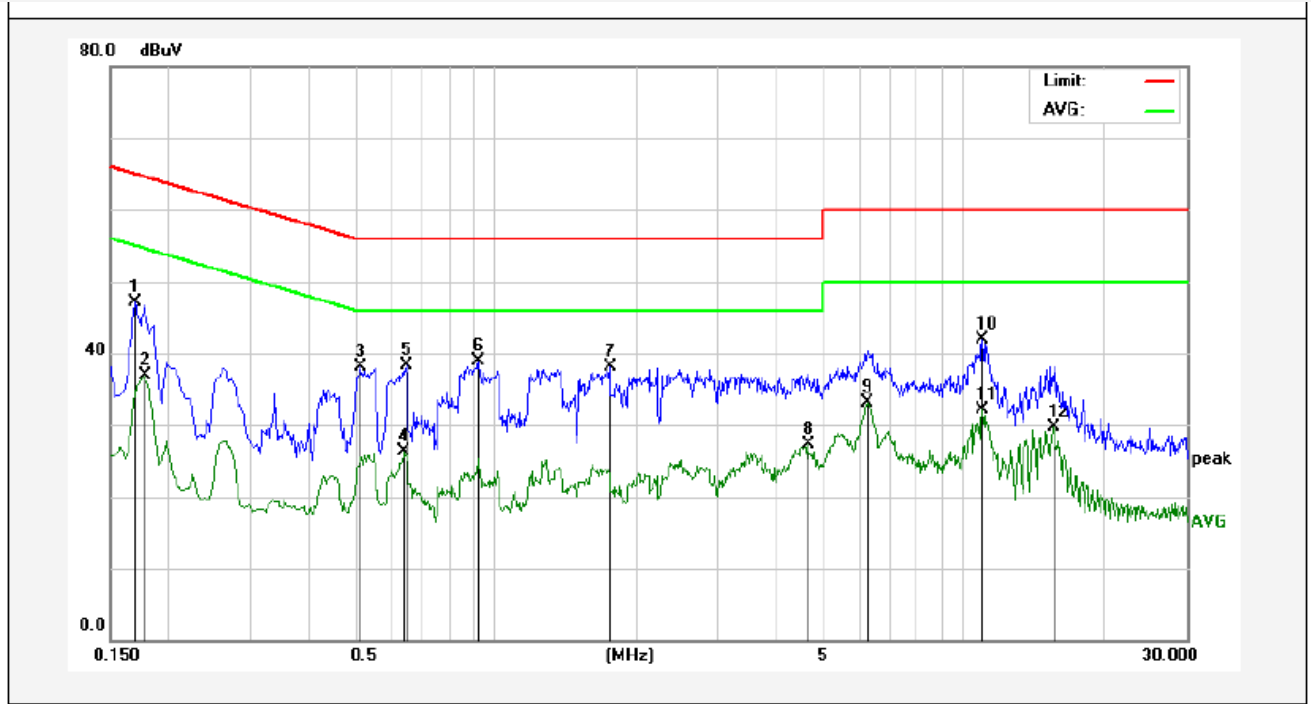

No.	Freq. (MHz)	Reading (dBuV)	Factor (dB)	Result (dBuV)	Limit (dBuV)	Over Limit (dB)	Detector	Remark
1	0.1700	27.11	19.90	47.01	47.11	-0.10	QP	
2	0.1780	16.92	19.90	36.82	36.92	-0.10	AVG	
3	0.5140	18.02	19.98	38.00	38.02	-0.02	QP	
4	0.6380	6.29	19.98	26.27	26.29	-0.02	AVG	
5	0.6460	18.31	20.00	38.31	38.31	0.00	QP	
6	0.9220	18.31	20.10	38.41	38.31	0.10	QP	
7	1.7540	18.08	20.14	38.22	38.08	0.14	QP	
8	4.6500	7.27	20.18	27.45	27.27	0.18	AVG	
9	6.2340	13.09	20.20	33.29	33.09	0.20	AVG	
10	10.9740	21.94	20.34	42.28	41.94	0.34	QP	
11	10.9740	12.19	20.34	32.53	32.19	0.34	AVG	
12	15.5260	9.79	20.26	30.05	29.79	0.26	AVG	

4. FCC Part 15.247 Requirements for DSSS & OFDM Modulation

4.1 Test Setup

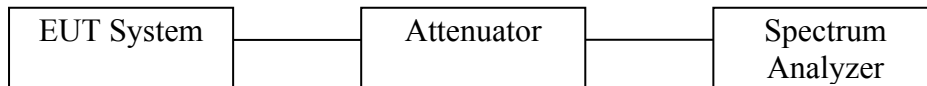

4.2 6dB Bandwidth

a. Limit

For the direct sequence systems, the minimum 6dB bandwidth shall be at least 500kHz.

b. Test Procedure

1. Place the EUT on the table and set it in the transmitting mode.
2. Remove the antenna from the EUT and then connect a low loss RF cable from the antenna port to the spectrum analyzer.
3. Set the spectrum analyzer as:
RBW = 100kHz, VBW $\geq 3 \times$ RBW = 300kHz,
Detector= Peak
Trace mode= Max hold.
Sweep- auto couple.
4. Mark the peak frequency and -6dB (upper and lower) frequency.
5. Repeat until all the rest channels are investigated.

20dB Bandwidth:

C63.10

Occupied Bandwidth (OBW=20dB Bandwidth)

1. Set RBW=1%~5% OBW
2. Set the VBW $\geq 3 \times$ RBW
3. Set the span range between 2 times and 5 times of the OBW
4. Sweep Time= Auto
Detector= Peak
Trace= Max hold
5. Once the reference level is established, the equipment is conditioned with typical modulating signals to produce the worst case (i.e. the widest) bandwidth. Unless otherwise specified for an unlicensed wireless device, measure the bandwidth at the -20dB levels with respect to the reference level.

c. Test Setup See 4.1

d. Test Equipment

Item	Equipment	Manufacturer	Model No.	Serial No.	Last Cal.	Cal. Interval
1.	Spectrum Analysis	Agilent	E4407B	US39390582	Apr. 16, 2016	1 Year
2.	Preamplifier	Instruments corporation	EMC011830	980100	Apr. 16, 2016	1 Year
3.	EMI Test Receiver	Rohde & Schwarz	ESPI	101604	Apr. 16, 2016	1 Year
4.	Double Ridged Horn Antenna	Instruments corporation	GTH-0118	351600	Apr. 19, 2016	1 Year
5.	Bilog Broadband Antenna	Schwarzbeck	VULB9163	VULB 9163-289	Apr. 19, 2016	1 Year
6.	Pre-amplifier	SONOMA	310N	186860	Apr. 16, 2016	1 Year
7.	EMI Test Software EZ-EMC	SHURPLE	N/A	N/A	N/A	N/A
8	Power Sensor	DAER	RPR3006W	15I00041SN046	Jun 30, 2016	1 Year
9	MXA Spectrum Analysis	Agilent	N9020A	MY51170037	Jun 30, 2016	1 Year
10	MXG RF Vector Signal Generator	Agilent	N5182A	MY48180656	Jun 30, 2016	1 Year
11	Signal Generator	Agilent	E4421B	MY41000743	Jun 30, 2016	1 Year
12	DC Power supply	IV	IV-8080	YQSB0096	Jun 30, 2016	1 Year
13	TEMP&HUMI PROGRAMMABLE CHAMBER	Bell Group	BE-THK-150M8	SE-0137	Mar 16, 2016	1 Year
14	Spectrum Analysis	Rohde & Schwarz	FSV40	132.1.3008K39-100965	Mar 17, 2016	1 Year
15	Pre-amplifier	Agilent	8449B	3008A00252	Mar 17, 2016	1 Year
16	Horn Antenna	SCHWARZBECK	BBHA9170	9170-068	Mar 17, 2016	1 Year

e. Test Results

Pass.

f. Test Data
6dB Bandwidth

ANT 0

Test mode: IEEE 802.11b

Channel	Frequency (MHz)	Bandwidth (MHz)	Limit (kHz)	Results
Low	2412	8.028	>500	Pass
Mid	2437	8.053		Pass
High	2462	8.061		Pass

Test mode: IEEE 802.11g

Channel	Frequency (MHz)	Bandwidth (MHz)	Limit (kHz)	Results
Low	2412	16.35	>500	Pass
Mid	2437	16.35		Pass
High	2462	16.36		Pass

Test mode: IEEE 802.11n (HT20)

Channel	Frequency (MHz)	Bandwidth (MHz)	Limit (kHz)	Results
Low	2412	17.60	>500	Pass
Mid	2437	17.32		Pass
High	2462	17.59		Pass

Test mode: IEEE 802.11n (HT40)

Channel	Frequency (MHz)	Bandwidth (MHz)	Limit (kHz)	Results
Low	2422	36.35	>500	Pass
Mid	2437	35.74		Pass
High	2452	36.30		Pass

Test Plots See the following page.

ANT 1

Test mode: IEEE 802.11b

Channel	Frequency (MHz)	Bandwidth (MHz)	Limit (kHz)	Results
Low	2412	8.082		Pass
Mid	2437	8.525	>500	Pass
High	2462	8.072		Pass

Test mode: IEEE 802.11g

Channel	Frequency (MHz)	Bandwidth (MHz)	Limit (kHz)	Results
Low	2412	16.38		Pass
Mid	2437	16.33	>500	Pass
High	2462	16.36		Pass

Test mode: IEEE 802.11n (HT20)

Channel	Frequency (MHz)	Bandwidth (MHz)	Limit (kHz)	Results
Low	2412	17.59		Pass
Mid	2437	17.58	>500	Pass
High	2462	17.58		Pass

Test mode: IEEE 802.11n (HT40)

Channel	Frequency (MHz)	Bandwidth (MHz)	Limit (kHz)	Results
Low	2422	36.40		Pass
Mid	2437	35.74	>500	Pass
High	2452	36.26		Pass

Test Plots See the following page.

ANT 0

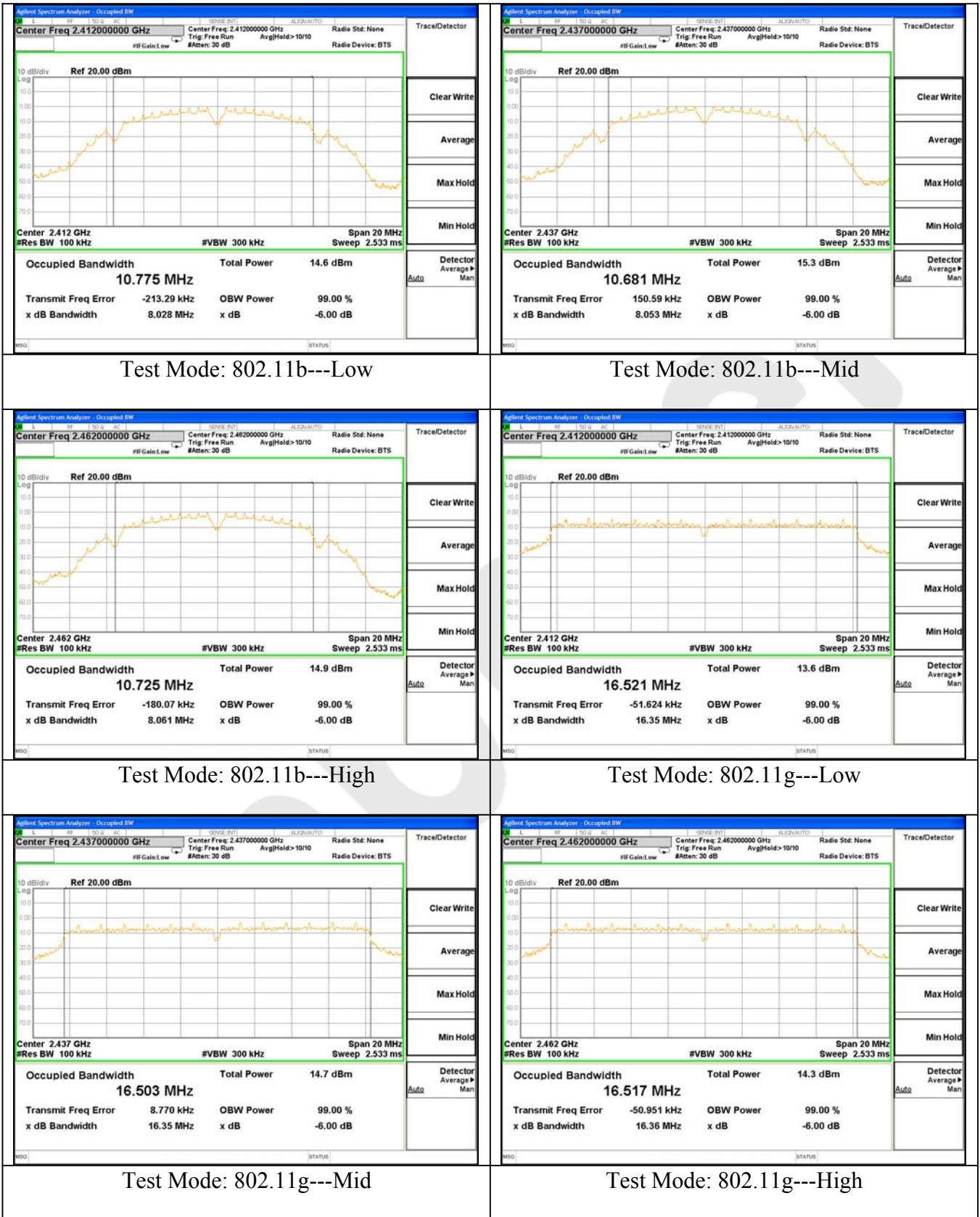

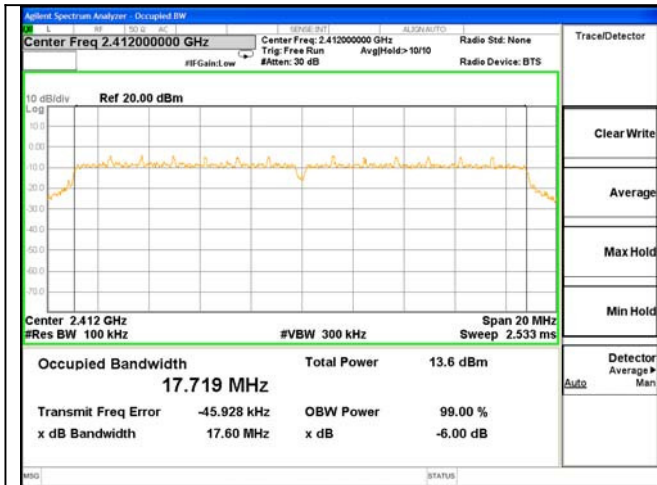

Test Mode: 802.11n20---Low

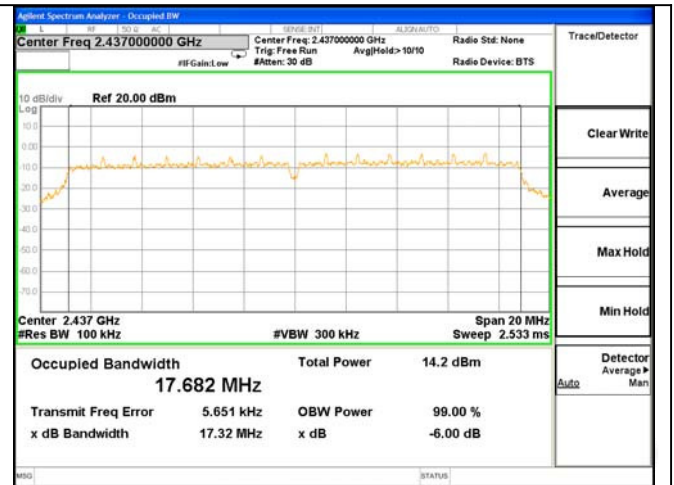

Test Mode: 802.11n20---Mid

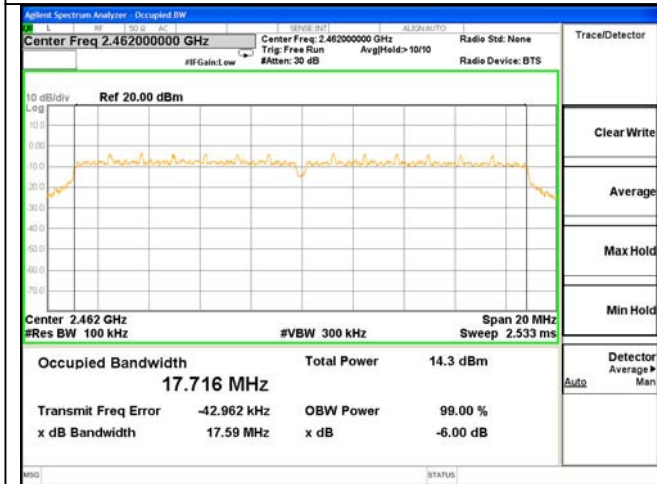

Test Mode: 802.11n20---High

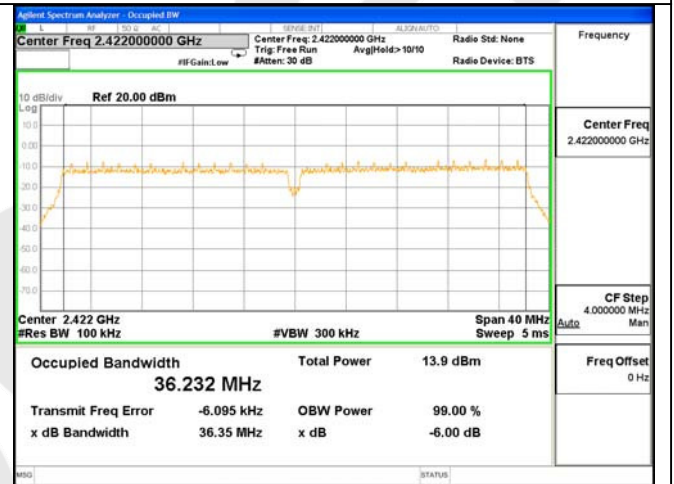

Test Mode: 802.11n40---Low

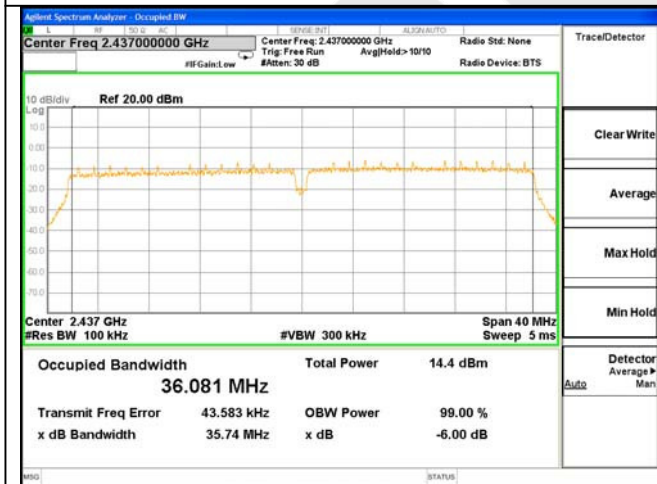

Test Mode: 802.11n40---Mid

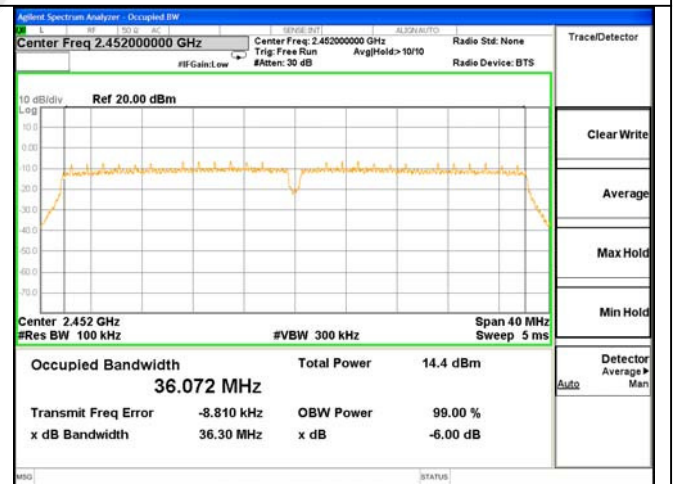

Test Mode: 802.11n40---High

ANT 1

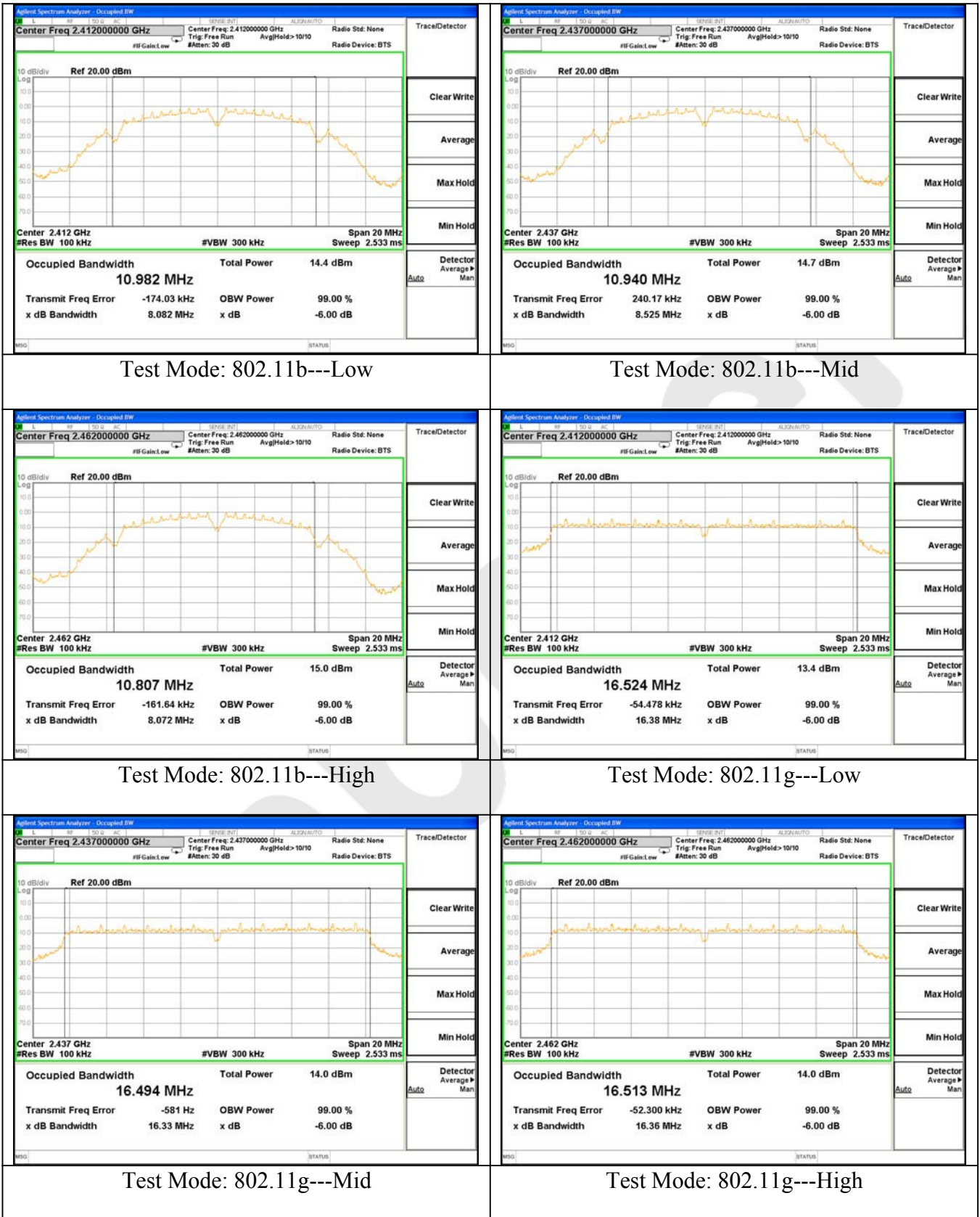

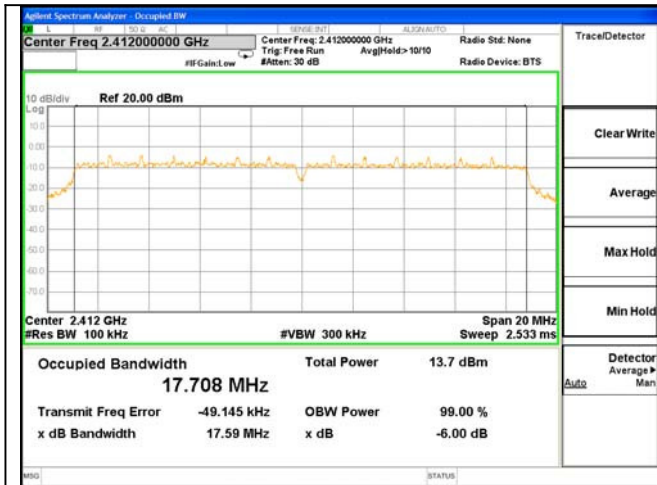

Test Mode: 802.11n20---Low

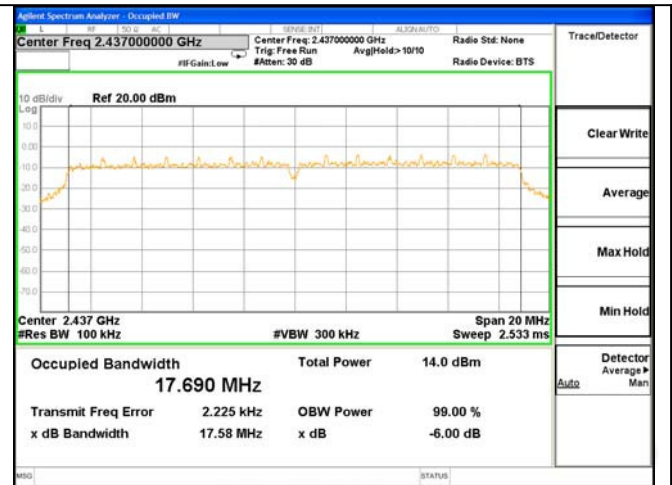

Test Mode: 802.11n20---Mid

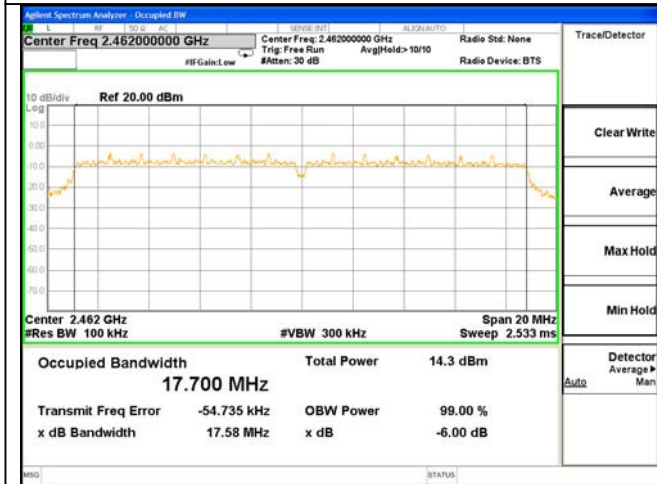

Test Mode: 802.11n20---High

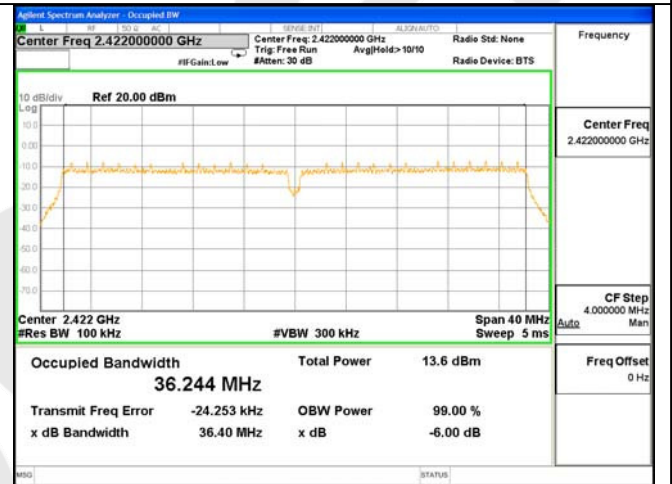

Test Mode: 802.11n40---Low

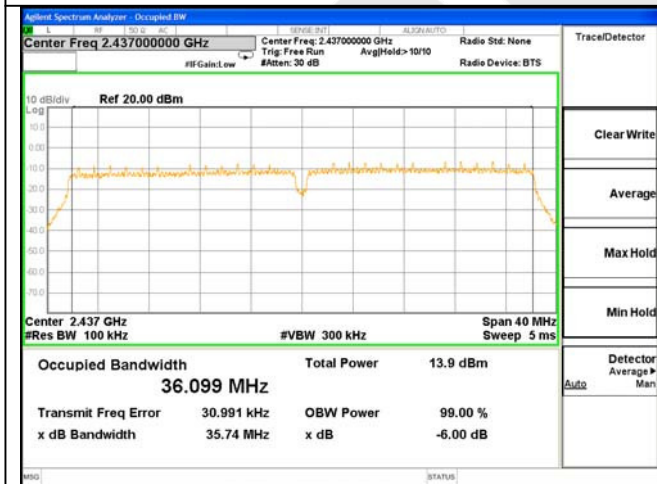

Test Mode: 802.11n40---Mid

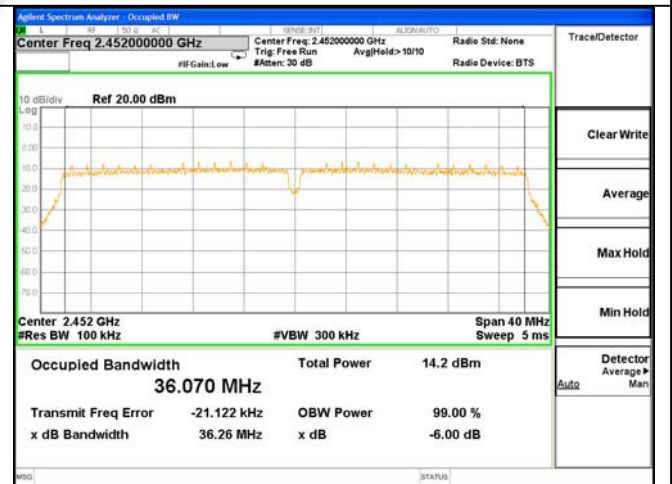

Test Mode: 802.11n40---High

20dB Bandwidth

ANT 0

Test mode: IEEE 802.11b

Channel	Frequency (MHz)	Bandwidth (MHz)	Results
Low	2412	13.19	Pass
Mid	2437	12.89	Pass
High	2462	13.11	Pass

Test mode: IEEE 802.11g

Channel	Frequency (MHz)	Bandwidth (MHz)	Results
Low	2412	20.44	Pass
Mid	2437	20.06	Pass
High	2462	20.50	Pass

Test mode: IEEE 802.11n (HT20)

Channel	Frequency (MHz)	Bandwidth (MHz)	Results
Low	2412	20.87	Pass
Mid	2437	20.87	Pass
High	2462	20.88	Pass

Test mode: IEEE 802.11n (HT40)

Channel	Frequency (MHz)	Bandwidth (MHz)	Results
Low	2422	39.59	Pass
Mid	2437	39.28	Pass
High	2452	39.39	Pass

Test Plots See the following page.

ANT 1

Test mode: IEEE 802.11b

Channel	Frequency (MHz)	Bandwidth (MHz)	Results
Low	2412	13.21	Pass
Mid	2437	13.18	Pass
High	2462	13.19	Pass

Test mode: IEEE 802.11g

Channel	Frequency (MHz)	Bandwidth (MHz)	Results
Low	2412	20.40	Pass
Mid	2437	20.15	Pass
High	2462	20.49	Pass

Test mode: IEEE 802.11n (HT20)

Channel	Frequency (MHz)	Bandwidth (MHz)	Results
Low	2412	20.88	Pass
Mid	2437	20.83	Pass
High	2462	20.76	Pass

Test mode: IEEE 802.11n (HT40)

Channel	Frequency (MHz)	Bandwidth (MHz)	Results
Low	2422	39.77	Pass
Mid	2437	38.55	Pass
High	2452	39.73	Pass

Test Plots See the following page.

ANT 0

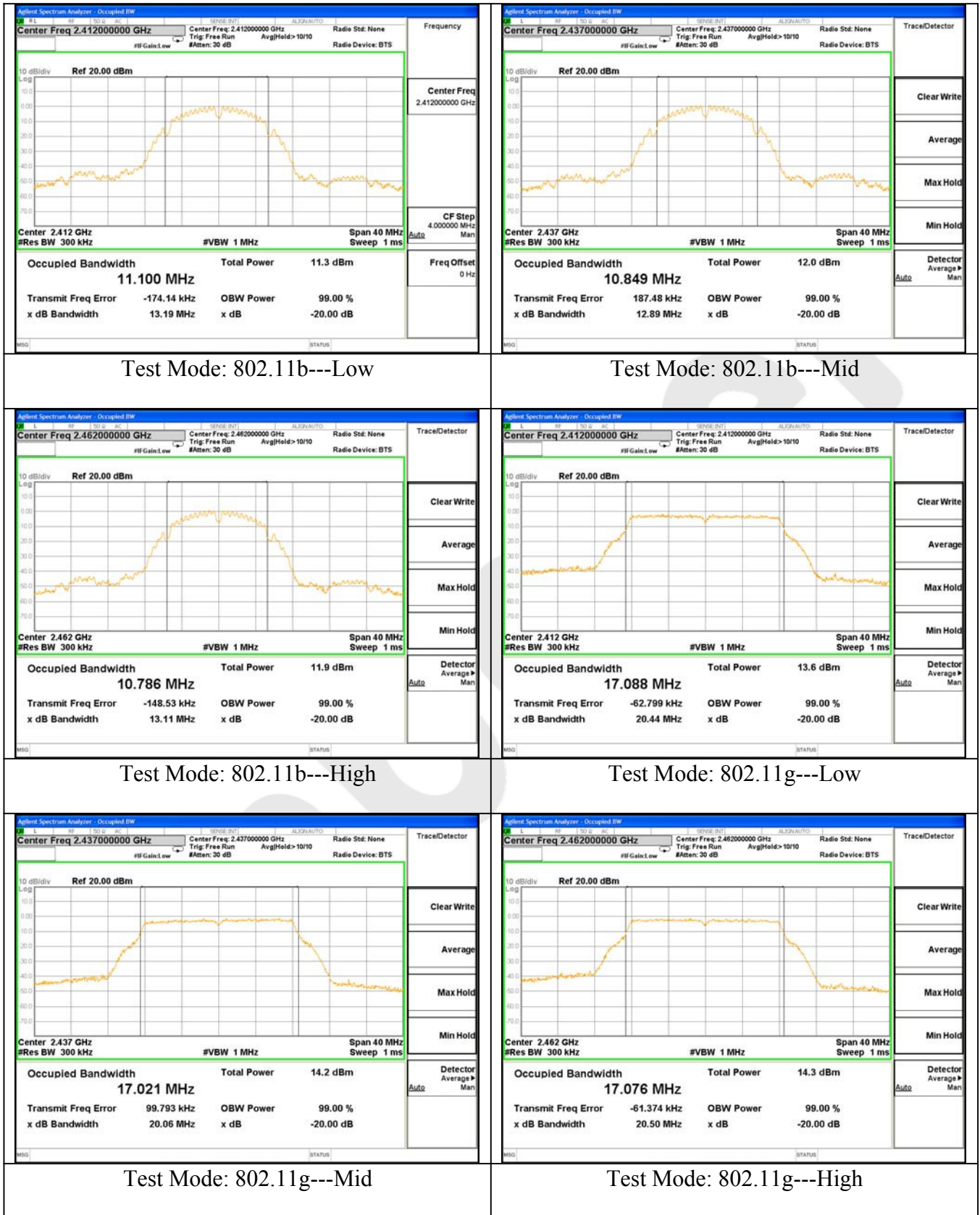

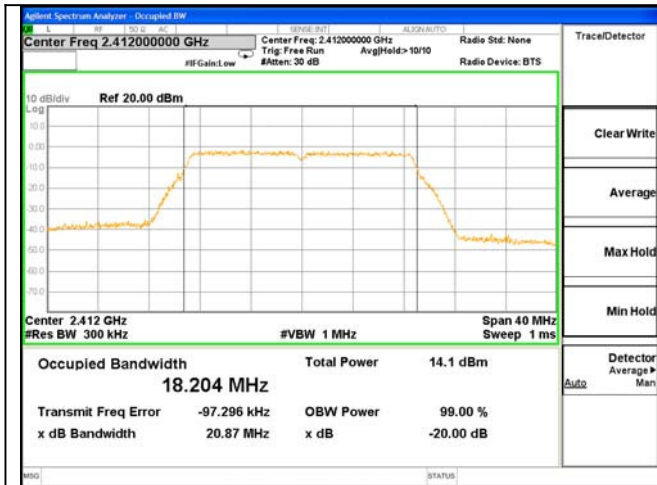

Test Mode: 802.11n20---Low

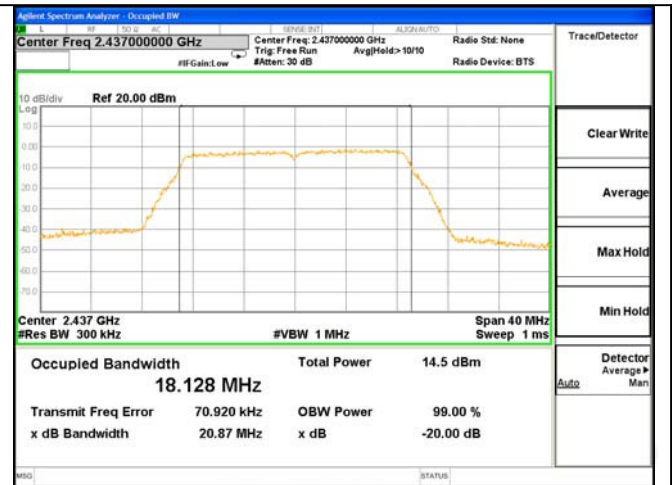

Test Mode: 802.11n20---Mid

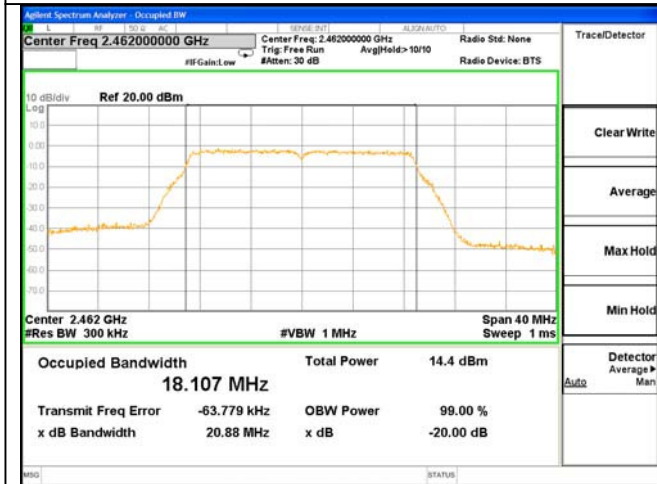

Test Mode: 802.11n20---High

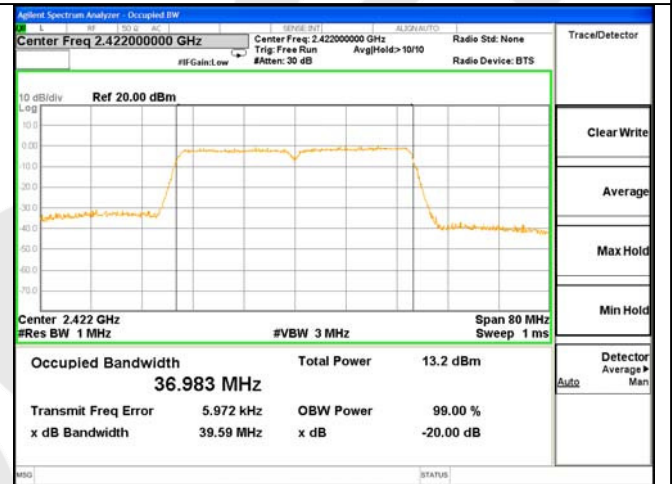

Test Mode: 802.11n40---Low

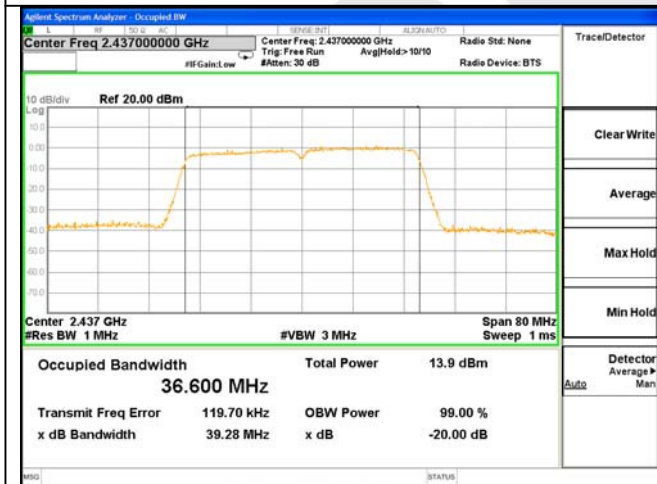

Test Mode: 802.11n40---Mid

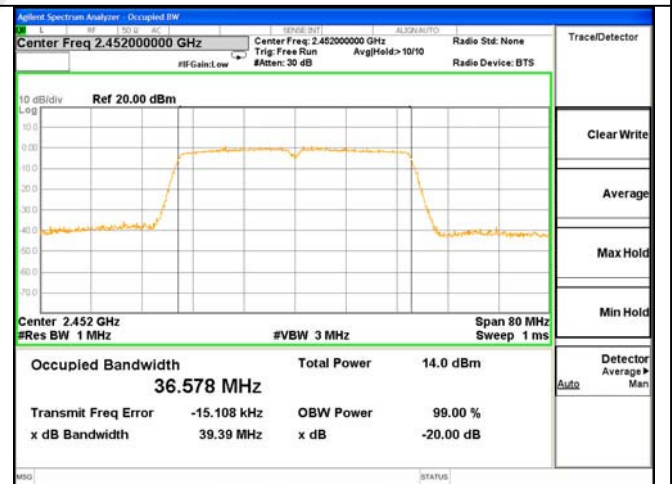

Test Mode: 802.11n40---High

ANT 1

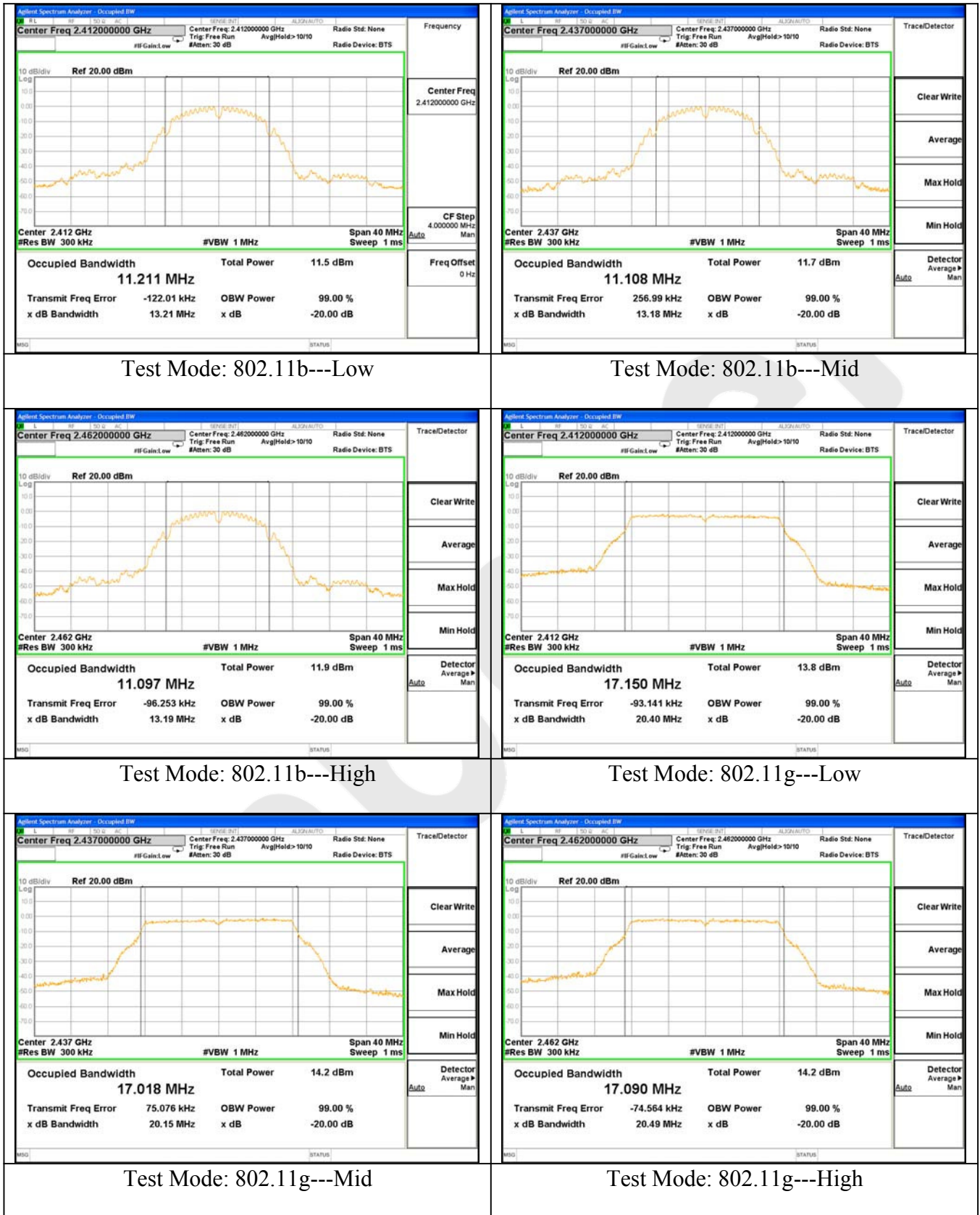

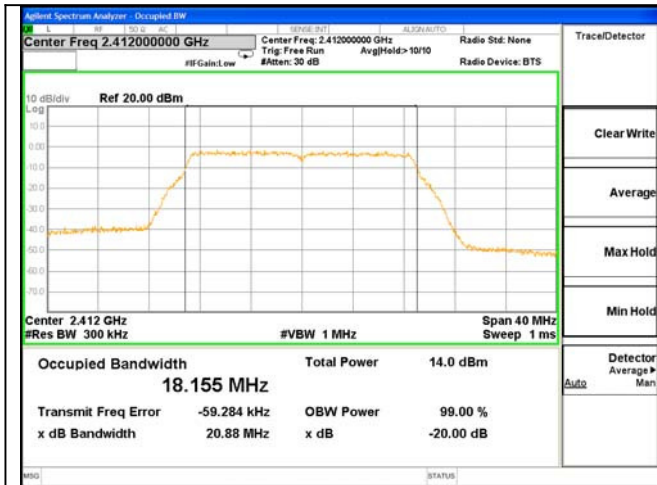

Test Mode: 802.11n20---Low

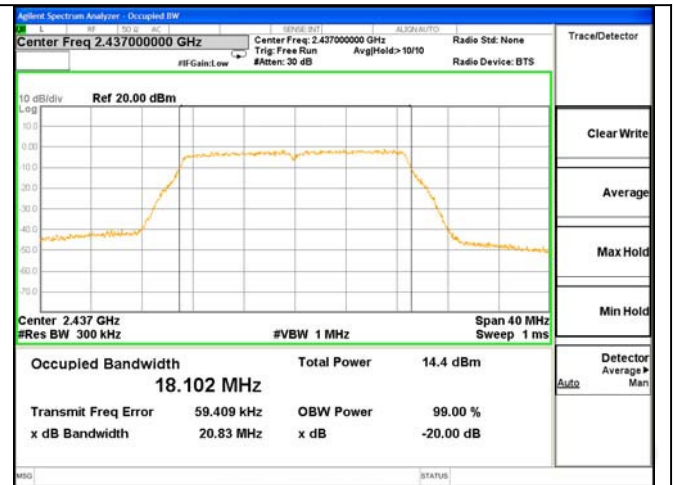

Test Mode: 802.11n20---Mid

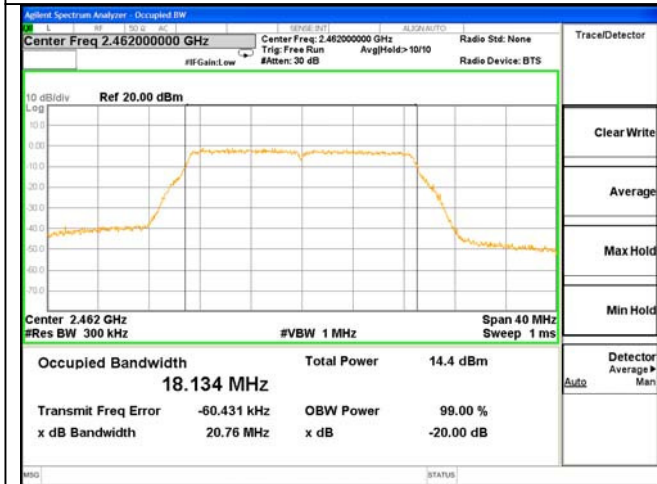

Test Mode: 802.11n20---High

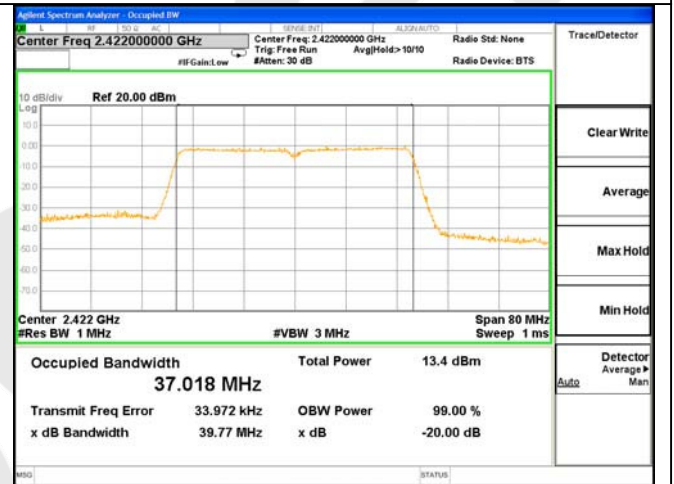

Test Mode: 802.11n40---Low

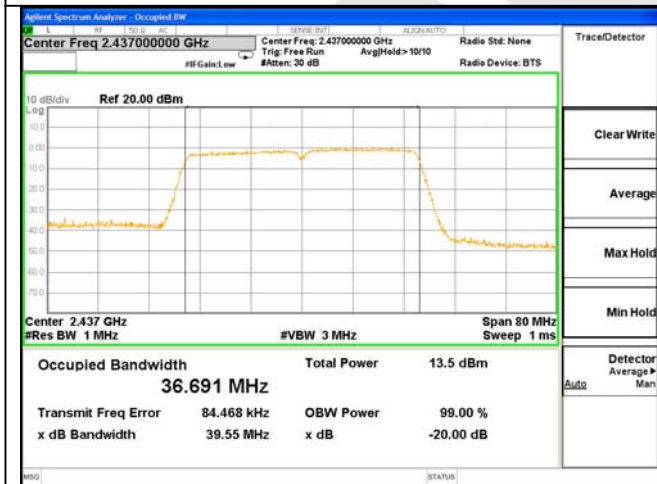

Test Mode: 802.11n40---Mid

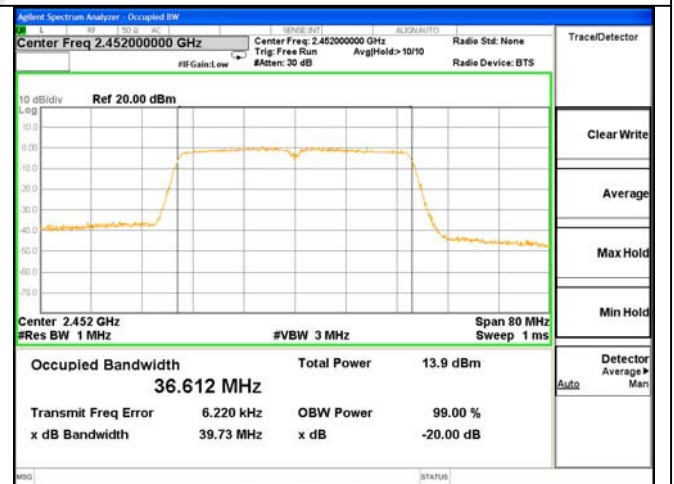

Test Mode: 802.11n40---High

4.3. Maximum Output Power Test

a. Limit

The maximum output power of the intentional radiator shall not exceed the following:

1. For systems using digital modulation in the bands of 902-928 MHz, 2400-2483.5 MHz, and 5725-5850 MHz: 1 watt (30dBm).
2. Except as shown in paragraphs (b)(3) (i), (ii) and (iii) of this section, if transmitting antenna of directional gain greater than 6 dBi are used the peak output power from the intentional radiator shall be reduced below the stated values in paragraphs (b)(1) or (b)(2) of this section, as appropriate, by the amount in dB that the directional gain of the antenna exceeds 6 dBi.

b. Configuration of Measurement

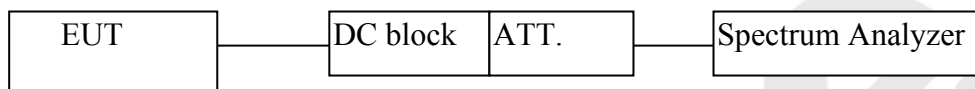

c. Data Rates

IEEE802.11b: Channel 1(2412MHz), Channel 6(2437MHz) and Channel 11(2462MHz) with 1 Mbps data rate (worst case) are chosen for the final testing.

IEEE802.11g: Channel 1(2412MHz), Channel 6(2437MHz) and Channel 11(2462MHz) with 6 Mbps data rate (the worst case) are chosen for the final testing.

IEEE802.11n (HT20): Channel 1(2412MHz), Channel 6(2437MHz) and Channel 11(2462MHz) with 6.5Mbps data rate (the worst case) are chosen for the final testing.

IEEE802.11n (HT40): Channel 3(2422MHz), Channel 6(2437MHz) and Channel 9(2452MHz) with 13.5Mbps data rate (the worst case) are chosen for the final testing.

d. Test Procedure

This test was according the kDB 558074 D01 DTS Meas Guidance v03r05 9.1.1:

1. Set span to at least 1.5 times the OBW.
2. Set the RBW = 1~5% of the OBW, not to exceed 1MHz.
3. Set VBW $\geq 3 * RBW$.
4. Detector = Average.
5. Sweep time = auto couple.
6. Trace mode = max hold.
7. Allow trace to fully stabilize.

e. Test Equipment

Same as the equipment listed in 4.2.

f. Test Results

Pass.

g. Test Data

ANT 0

Test mode: IEEE 802.11b

Channel	Frequency (MHz)	Maximum transmit power (dBm)	Limit		Result
			(dBm)	(watts)	
Low	2412	11.75	27.99	0.630	Pass
Mid	2437	12.10			Pass
High	2462	12.12			Pass

Test mode: IEEE 802.11g

Channel	Frequency (MHz)	Maximum transmit power (dBm)	Limit		Result
			(dBm)	(watts)	
Low	2412	13.85	27.99	0.630	Pass
Mid	2437	14.34			Pass
High	2462	14.39			Pass

Test mode: IEEE 802.11n (HT20)

Channel	Frequency (MHz)	Maximum transmit power (dBm)	Limit		Result
			(dBm)	(watts)	
Low	2412	14.13	27.99	0.630	Pass
Mid	2437	14.40			Pass
High	2462	14.37			Pass

Test mode: IEEE 802.11n (HT40)

Channel	Frequency (MHz)	Maximum transmit power (dBm)	Limit		Result
			(dBm)	(watts)	
Low	2422	13.27	27.99	0.630	Pass
Mid	2437	13.74			Pass
High	2452	13.97			Pass

ANT 1

Test mode: IEEE 802.11b

Channel	Frequency (MHz)	Maximum transmit power (dBm)	Limit		Result
			(dBm)	(watts)	
Low	2412	11.20	27.99	0.630	Pass
Mid	2437	11.76			Pass
High	2462	11.91			Pass

Test mode: IEEE 802.11g

Channel	Frequency (MHz)	Maximum transmit power (dBm)	Limit		Result
			(dBm)	(watts)	
Low	2412	13.67	27.99	0.630	Pass
Mid	2437	14.37			Pass
High	2462	14.29			Pass

Test mode: IEEE 802.11n (HT20)

Channel	Frequency (MHz)	Maximum transmit power (dBm)	Limit		Result
			(dBm)	(watts)	
Low	2412	13.61	27.99	0.630	Pass
Mid	2437	14.57			Pass
High	2462	14.80			Pass

Test mode: IEEE 802.11n (HT40)

Channel	Frequency (MHz)	Maximum transmit power (dBm)	Limit		Result
			(dBm)	(watts)	
Low	2422	13.10	27.99	0.630	Pass
Mid	2437	13.90			Pass
High	2452	13.82			Pass

Channel	Channel Frequency (MHz)	ANT 0 Output Power (dBm)	ANT 1 Output Power (dBm)	Data Rate (Mbps)	MIMO Output Power (dBm)	Limit (dBm)
802.11n (20M MIMO) mode						
Low	2412	14.13	13.61	MCS0	16.89	27.99
Middle	2437	14.40	14.57	MCS0	17.50	27.99
High	2462	14.37	14.80	MCS0	17.60	27.99
802.11n (40M MIMO) mode						
Low	2422	13.27	13.10	MCS0	16.20	27.99
Middle	2437	13.74	13.90	MCS0	16.83	27.99
High	2452	13.97	13.82	MCS0	16.91	27.99

Remark:

Antenna 0 Gain= 5 dBi
Antenna 1 Gain= 5 dBi
Array Gain= 8.01 dBi= $G_{ANT}+10*\log(N_{ANT})$ dBi

Limit=30dBm-(8.01-6)=27.99

ANT 0

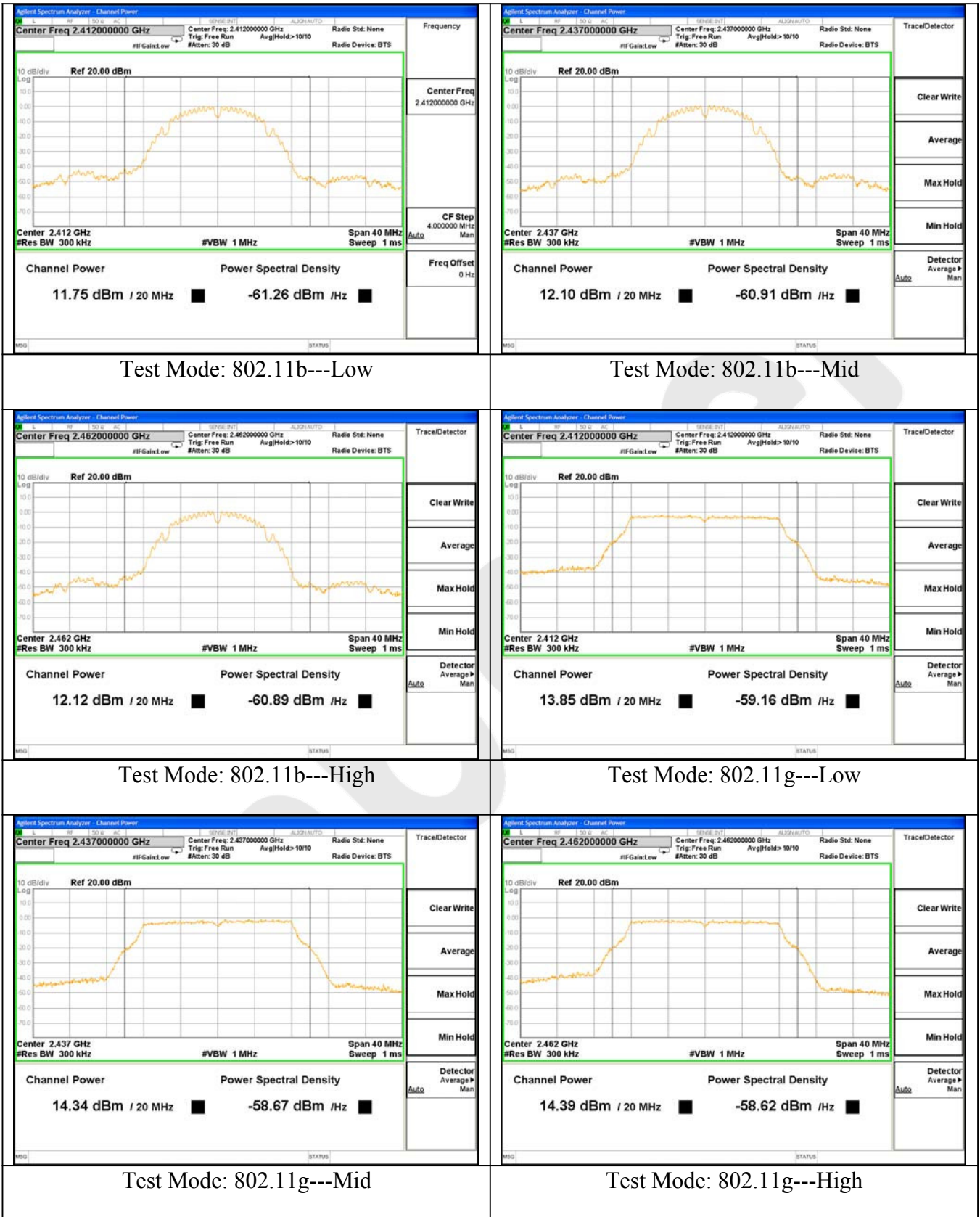



Test Mode: 802.11n20---Low



Test Mode: 802.11n20---Mid



Test Mode: 802.11n20---High



Test Mode: 802.11n40---Low



Test Mode: 802.11n40---Mid

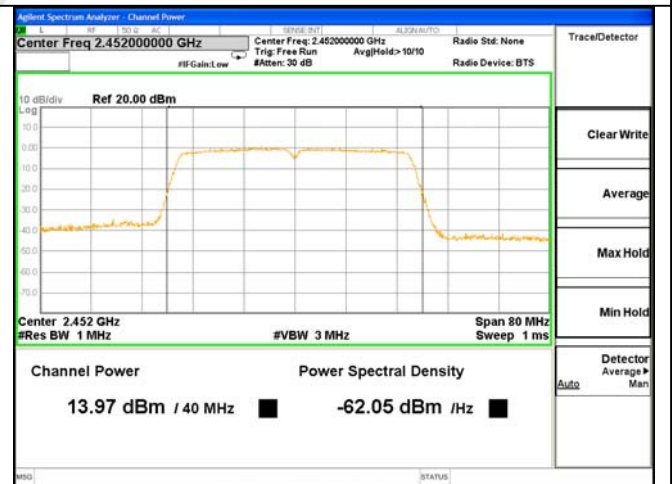

Test Mode: 802.11n40---High

ANT 1

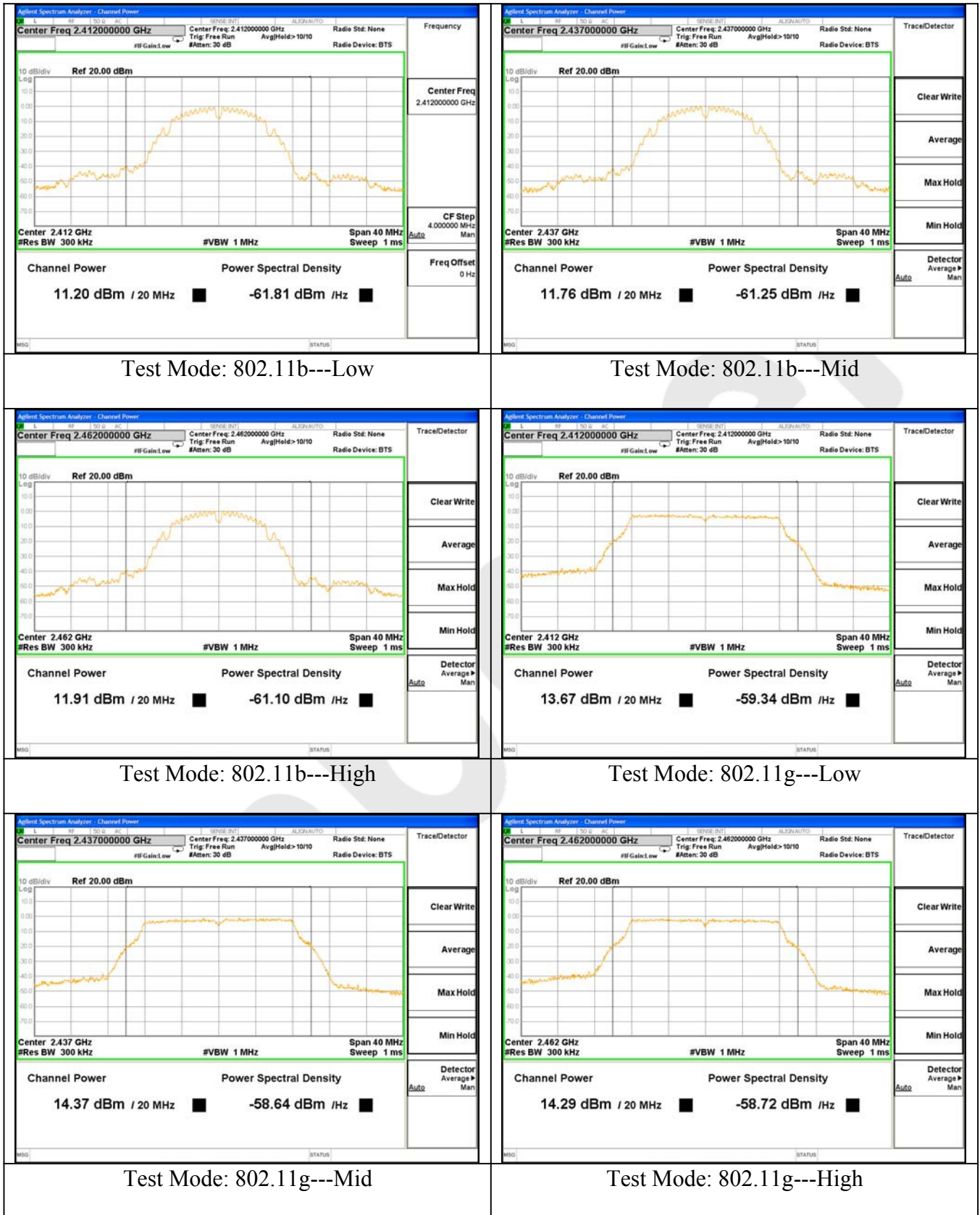



Test Mode: 802.11n20---Low



Test Mode: 802.11n20---Mid



Test Mode: 802.11n20---High

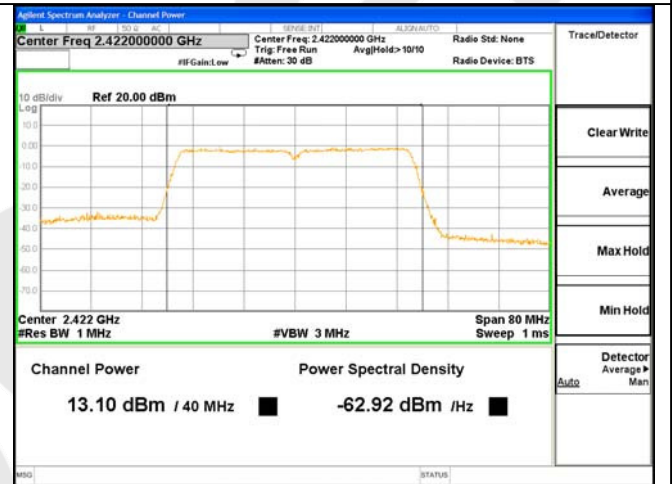

Test Mode: 802.11n40---Low



Test Mode: 802.11n40---Mid

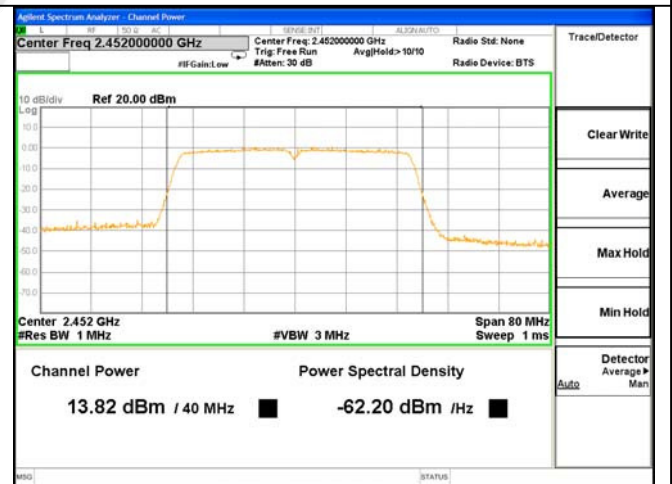

Test Mode: 802.11n40---High

4.4. Band Edges Measurement

a. Limit

According to §15.247(c), in any 100 kHz bandwidth outside the frequency bands in which the spread spectrum intentional radiator is operating, the radio frequency power that is produced by the intentional radiator shall be at least 20dB below that in the 100kHz bandwidth within the band that contains the highest level of the desired power, In addition, radiated emissions which fall in the restricted bands, as defined in §15.205(a), must also comply with the radiated emission limits specified in §15.209(a).

b. Test Procedure

1. Conducted Method:

- 1) Set RBW=100KHz, VBW=300KHz
- 2) Detector=peak
- 3) Sweep time= auto
- 4) Trace mode=max hold.

2. Radiated Method:

- 1) For below 1GHz: The EUT is placed on a turntable, which is 0.8m above the ground plane. The EUT is tested in 9*6*6 Chamber.
For above 1GHz: The EUT is placed on a turntable, which is 1.5m above the ground plane. The EUT is tested in 9*6*6 Chamber.
- 2) The turntable shall be rotated for 360 degrees to determine the position of maximum emission level.
- 3) EUT is set 3m away from the receiving antenna, which is varied from 1m to 4m to find out the highest emission.
- 4) Peak detector: RBW=1MHz, VBW=3MHz, SWT=AUTO
Average detector: RBW=1MHz, VBW=10Hz, SWT=AUTO
The EUT is tested in 9*6*6 Chamber.
- 5) Repeat the procedures until all the PEAK and AVERAGE versus POLARIZATION are measured.

30M to 1G emissions:

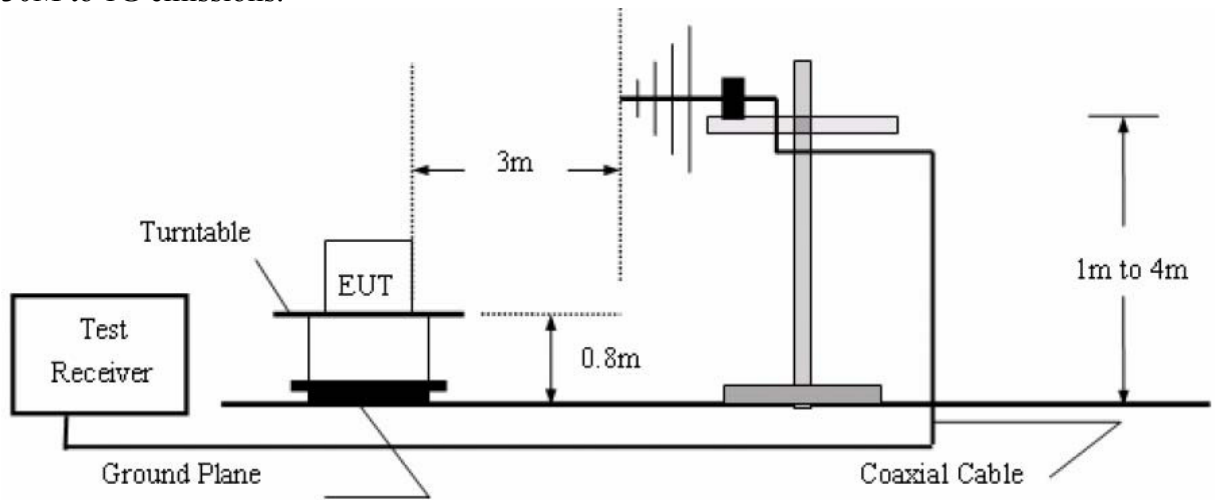

1G to 40G emissions:

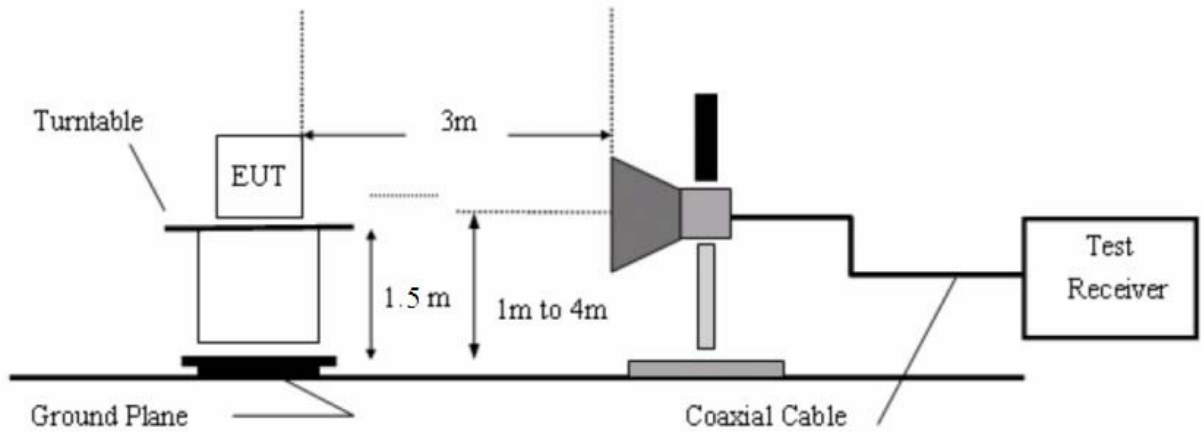

c. Test Equipment

Same as the equipment listed in 4.2.

d. Test Results

Pass.

e. Test Plots

See the following page.

ANT 0

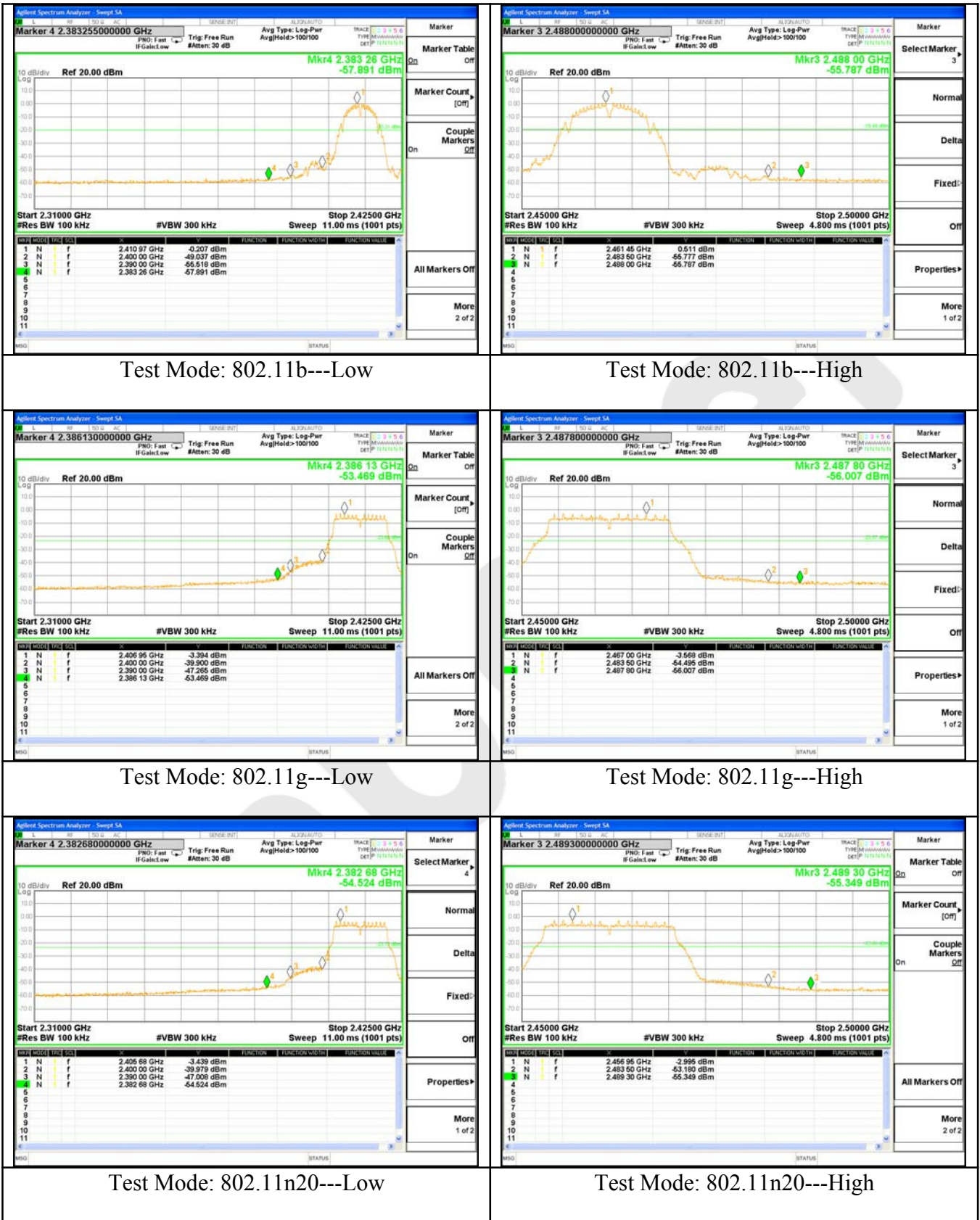

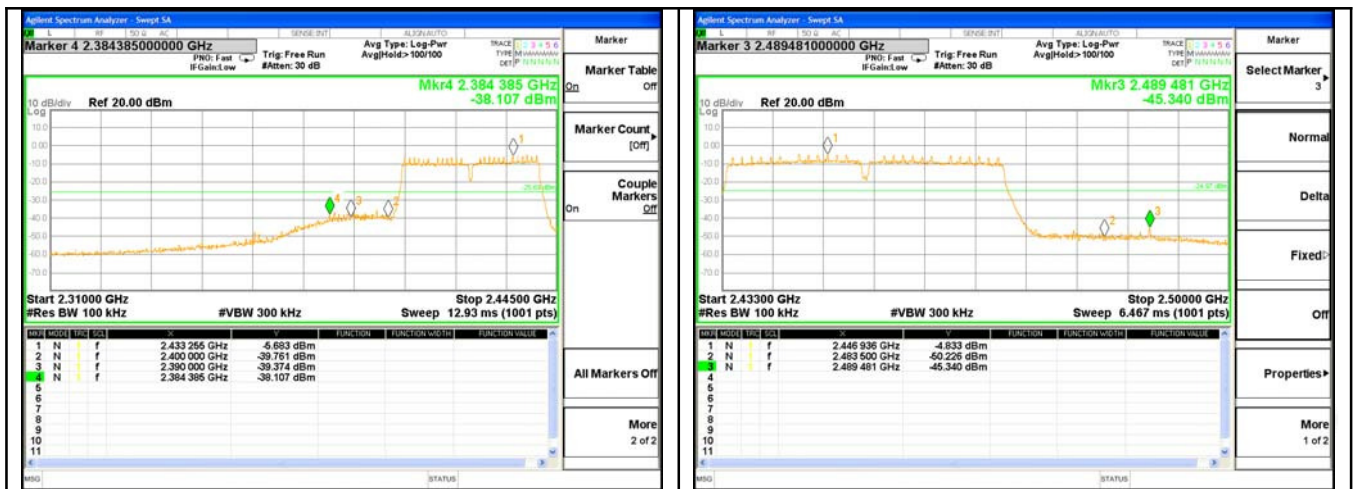

Test Mode: 802.11n40---Low

Test Mode: 802.11n40---High



ANT 1

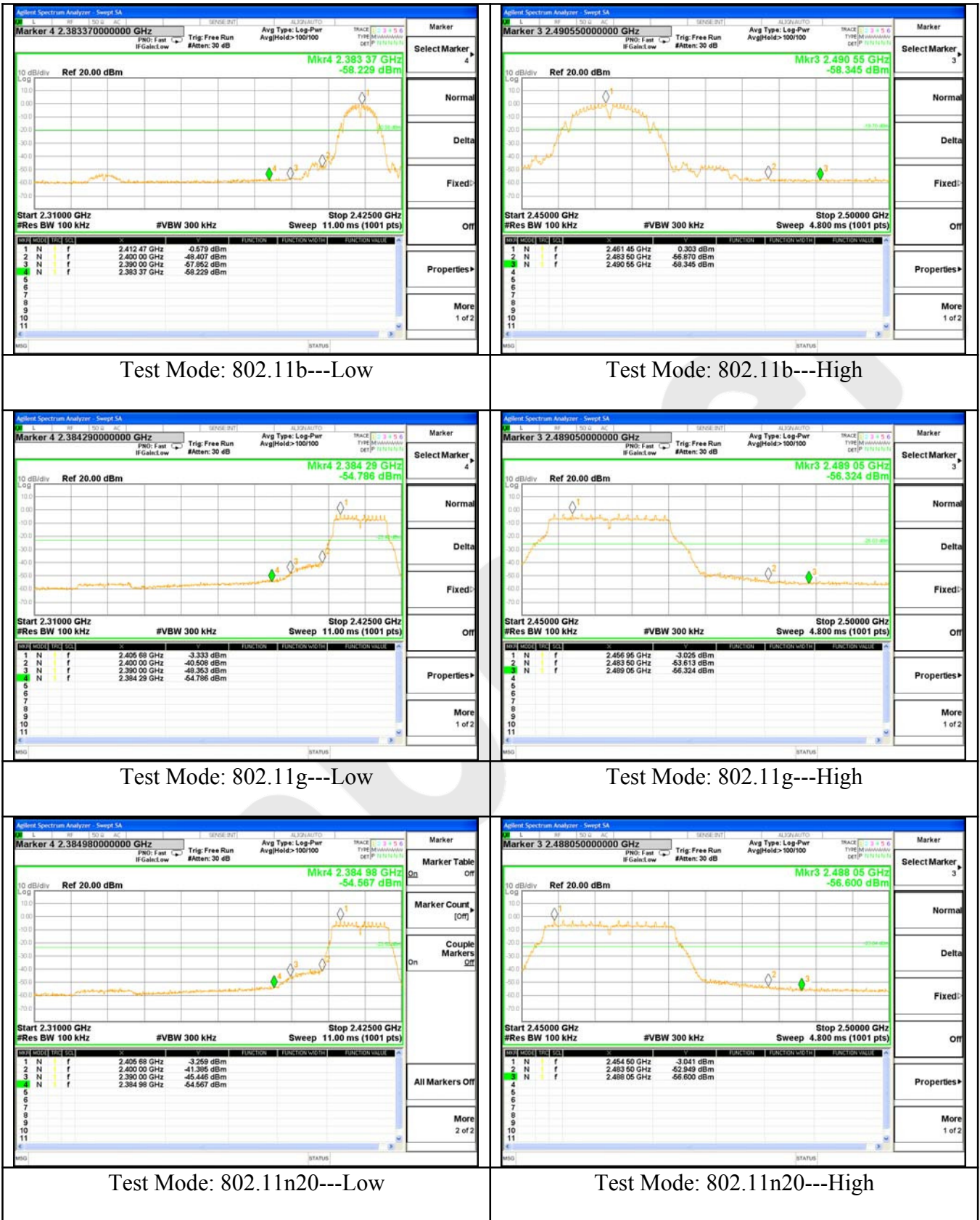



Test Mode: 802.11n40---Low

Test Mode: 802.11n40---High



ANT 0

Test Mode: 802.11b

2412MHz

Horizontal-PEAK:

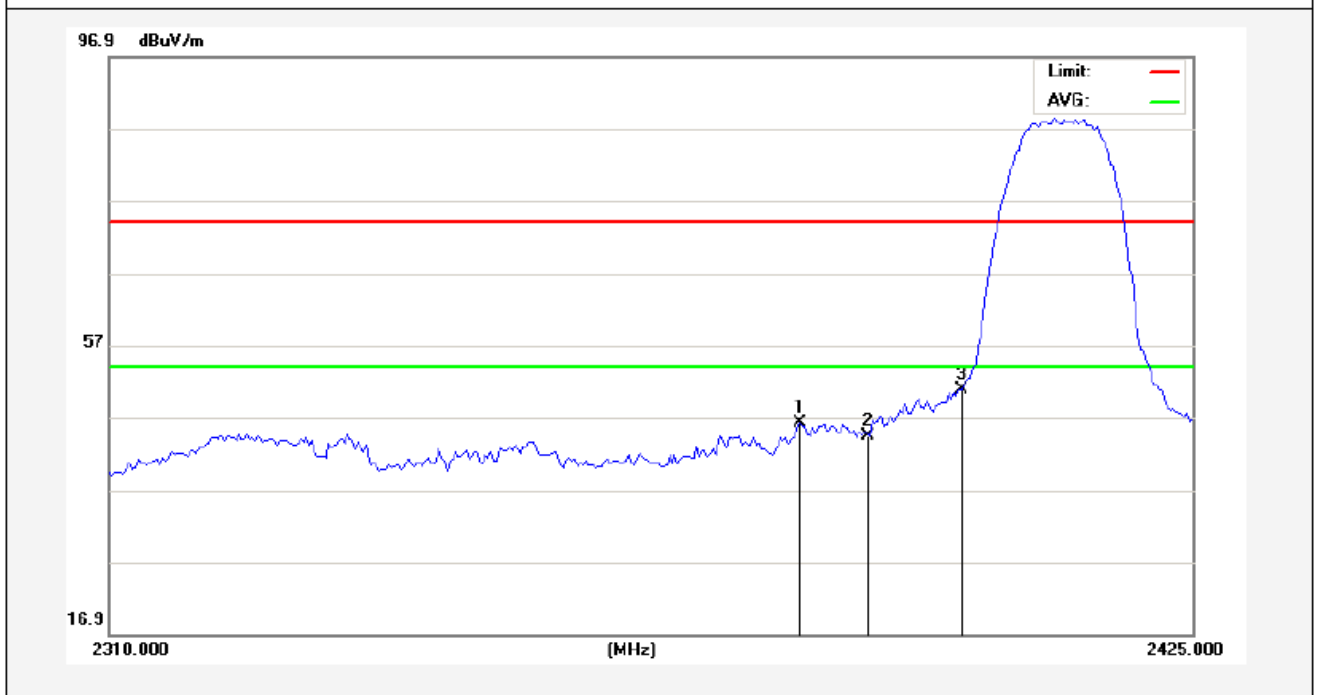

No.	Freq. (MHz)	Reading (dBuV/m)	Factor (dB/m)	Result (dBuV/m)	Limit (dBuV/)	Over Limit (dB)	Detector	Height (cm)	degree (deg)	Remark
1	2382.738	48.79	-2.53	46.26	74.00	-27.74	peak			
2	2390.000	46.88	-2.51	44.37	74.00	-29.63	peak			
3	2400.000	53.32	-2.49	50.83	74.00	-23.17	peak			

ANT 0

Horizontal-AV:

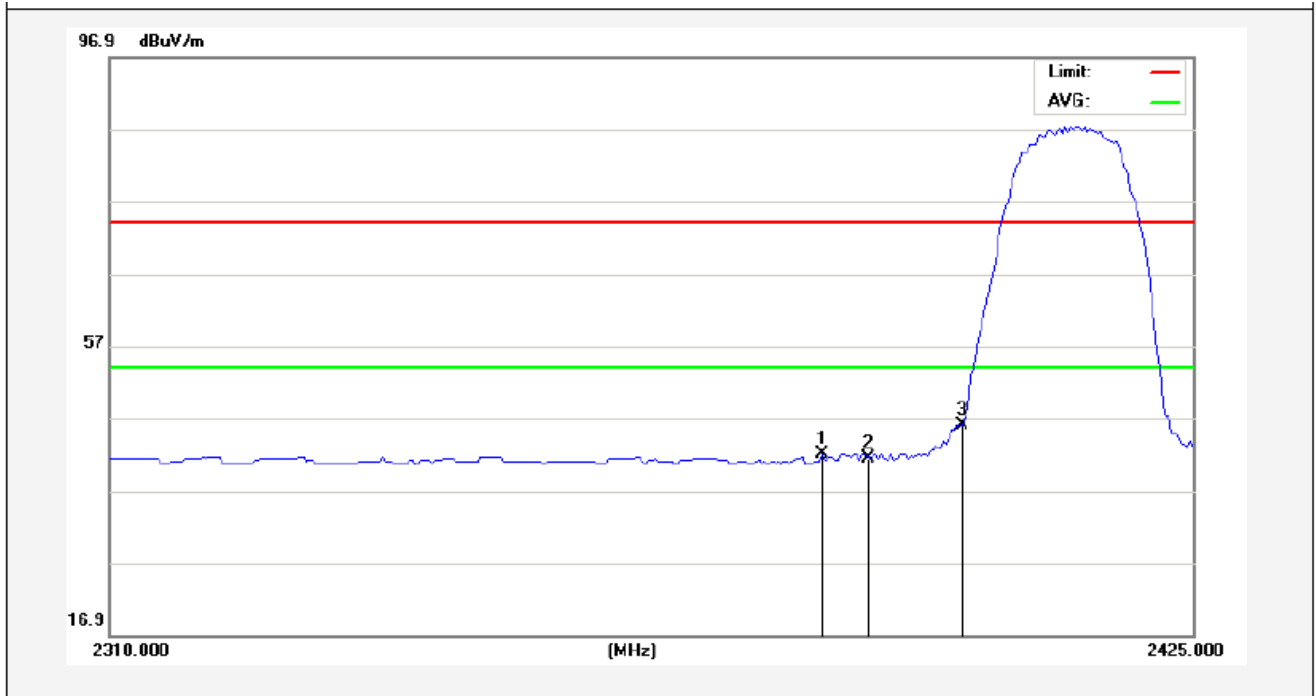

No.	Freq. (MHz)	Reading (dBuV/m)	Factor (dB/m)	Result (dBuV/m)	Limit (dBuV/)	Over Limit (dB)	Detector	Height (cm)	degree (deg)	Remark
1	2385.037	44.60	-2.53	42.07	54.00	-11.93	AVG			
2	2390.000	43.95	-2.51	41.44	54.00	-12.56	AVG			
3	2400.000	48.43	-2.49	45.94	54.00	-8.06	AVG			

Anbotek

Test Mode: 802.11b
2412MHz
Vertical-PEAK:

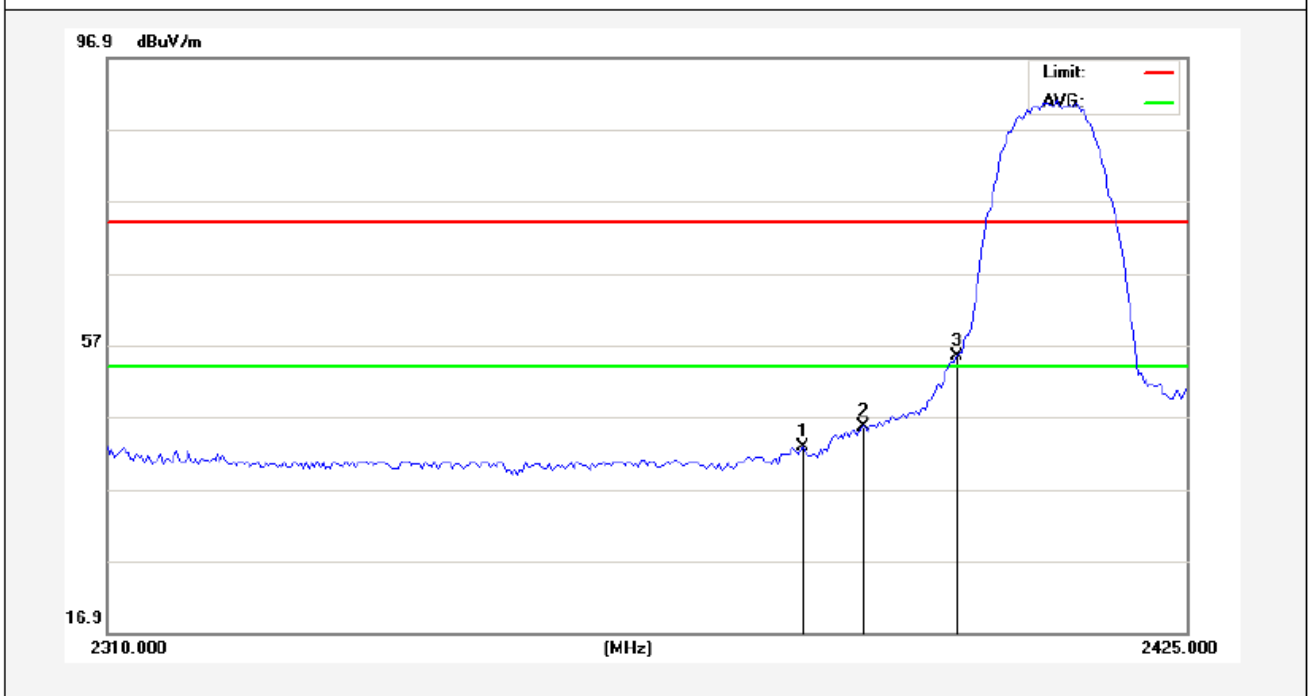

No.	Freq. (MHz)	Reading (dBuV/m)	Factor (dB/m)	Result (dBuV/m)	Limit (dBuV/)	Over Limit (dB)	Detector	Height (cm)	degree (deg)	Remark
1	2383.600	45.34	-2.53	42.81	74.00	-31.19	peak			
2	2390.000	48.11	-2.51	45.60	74.00	-28.40	peak			
3	2400.000	57.81	-2.49	55.32	74.00	-18.68	peak			

Anbotek

Vertical-AV:

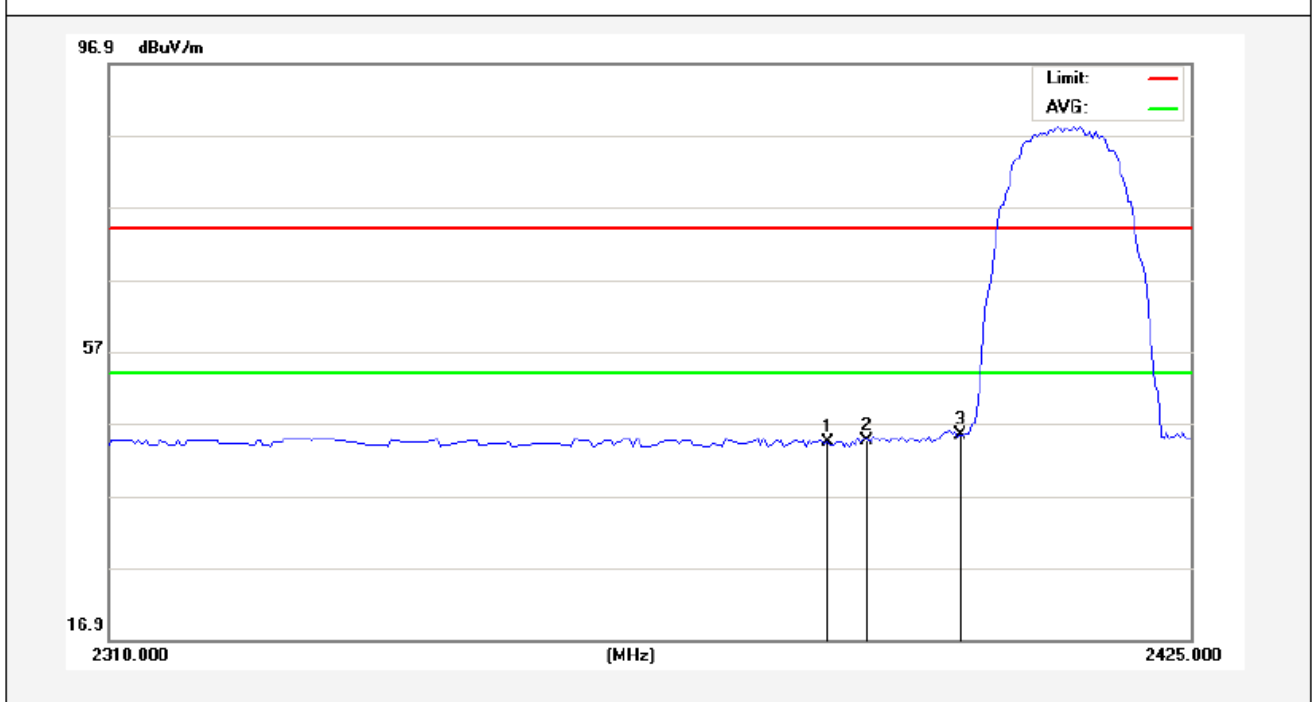

No.	Freq. (MHz)	Reading (dBuV/m)	Factor (dB/m)	Result (dBuV/m)	Limit (dBuV/)	Over Limit (dB)	Detector	Height (cm)	degree (deg)	Remark
1	2385.900	46.91	-2.52	44.39	54.00	-9.61	AVG			
2	2390.000	47.14	-2.51	44.63	54.00	-9.37	AVG			
3	2400.000	47.96	-2.49	45.47	54.00	-8.53	AVG			

Anbotek

Test Mode: 802.11b
2462MHz
Horizontal-PEAK:

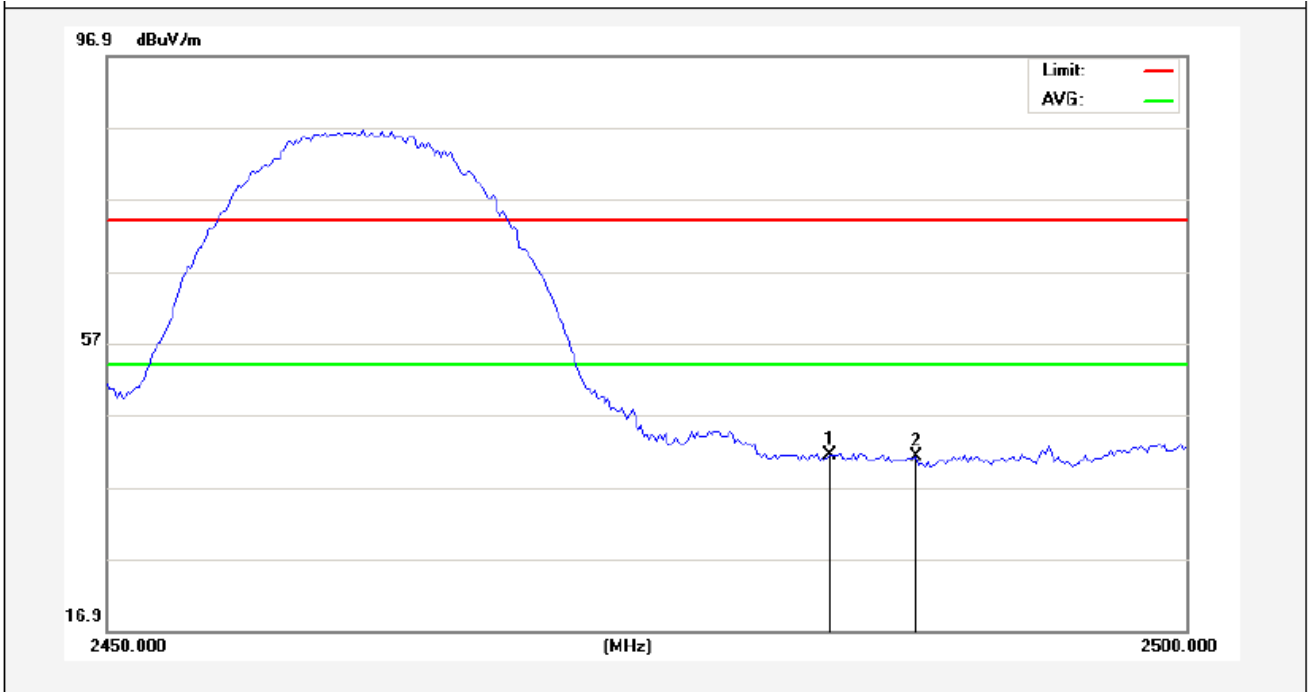

No.	Freq. (MHz)	Reading (dBuV/m)	Factor (dB/m)	Result (dBuV/m)	Limit (dBuV)	Over Limit (dB)	Detector	Height (cm)	degree (deg)	Remark
1	2483.500	43.80	-2.31	41.49	74.00	-32.51	peak			
2	2487.500	43.53	-2.30	41.23	74.00	-32.77	peak			

Anbotek

Horizontal-AV:

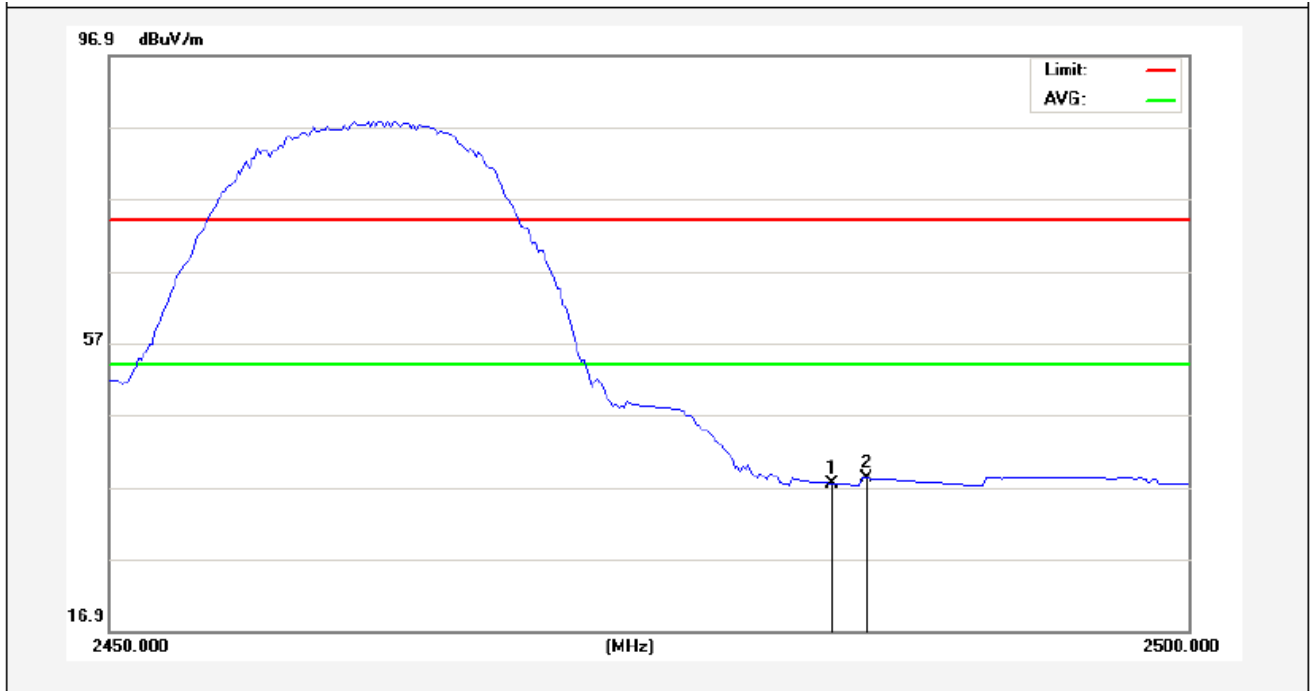

No.	Freq. (MHz)	Reading (dBuV/m)	Factor (dB/m)	Result (dBuV/m)	Limit (dBuV/)	Over Limit (dB)	Detector	Height (cm)	degree (deg)	Remark
1	2483.500	39.76	-2.31	37.45	54.00	-16.55	AVG			
2	2485.125	40.41	-2.30	38.11	54.00	-15.89	AVG			

Anbotek

Test Mode: 802.11b
2462MHz
Vertical-PEAK:

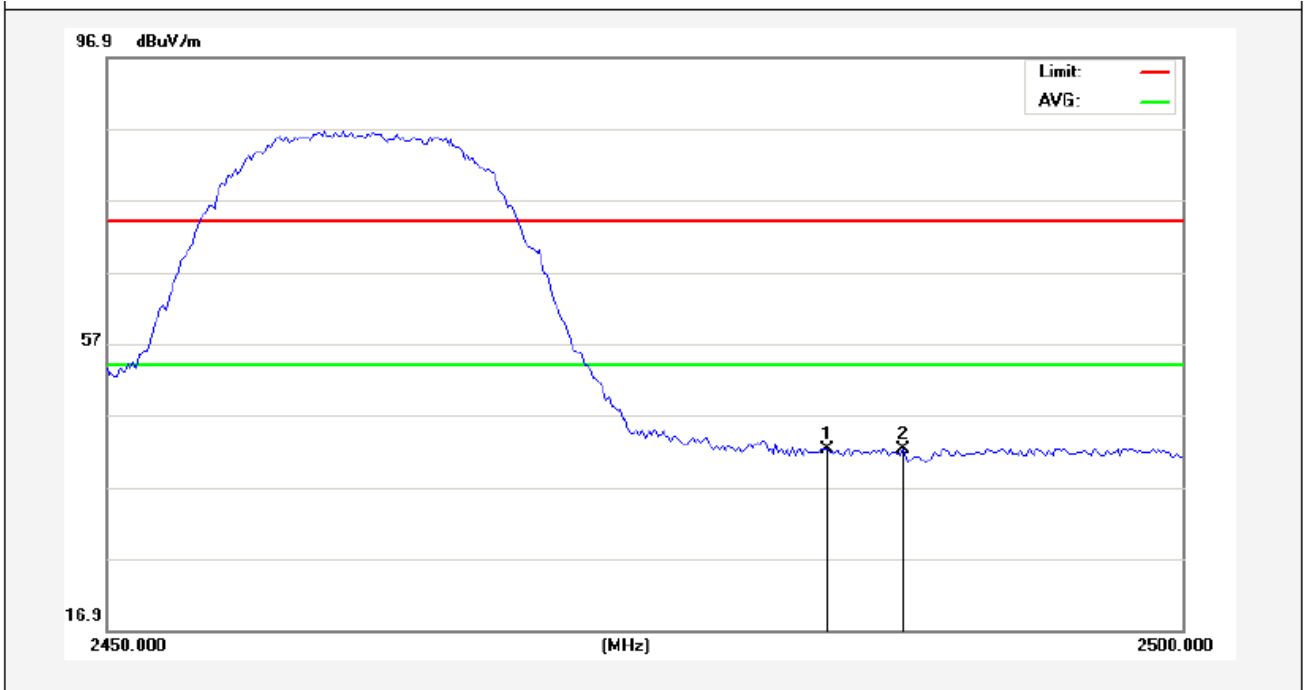

No.	Freq. (MHz)	Reading (dBuV/m)	Factor (dB/m)	Result (dBuV/m)	Limit (dBuV/)	Over Limit (dB)	Detector	Height (cm)	degree (deg)	Remark
1	2483.500	44.53	-2.31	42.22	74.00	-31.78	peak			
2	2487.000	44.54	-2.30	42.24	74.00	-31.76	peak			

Anbotek

Vertical-AV:

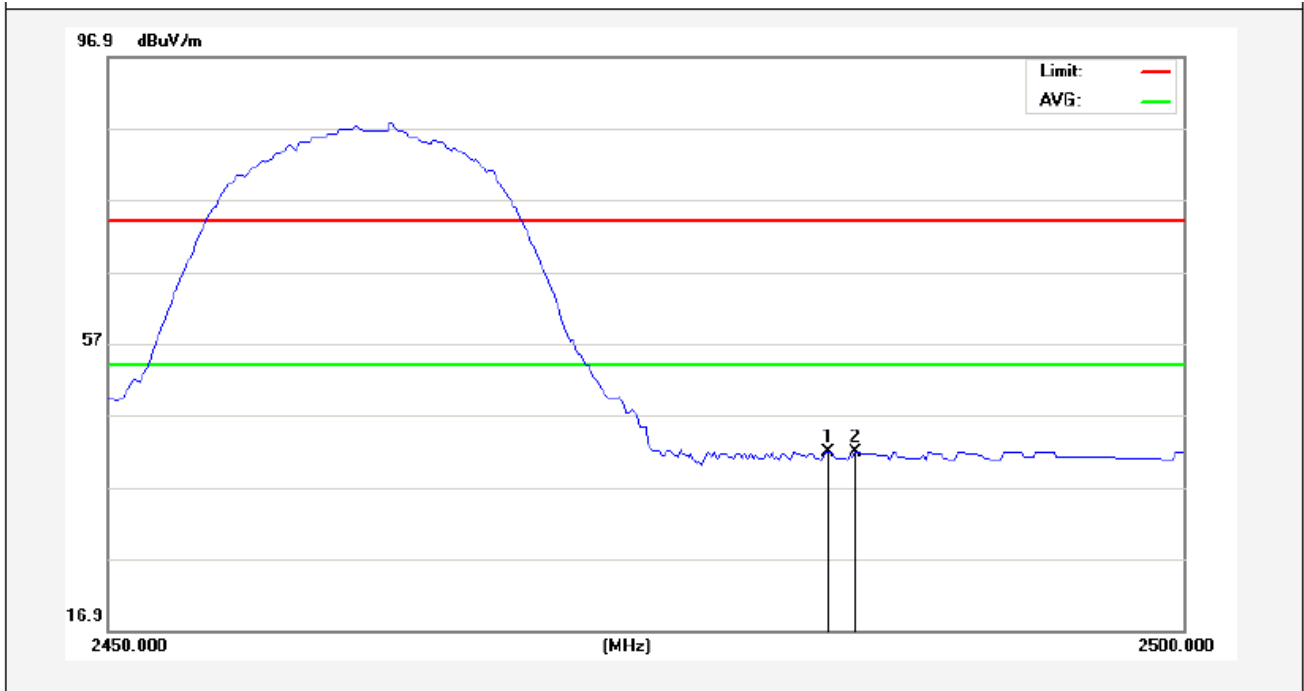

No.	Freq. (MHz)	Reading (dBuV/m)	Factor (dB/m)	Result (dBuV/m)	Limit (dBuV/)	Over Limit (dB)	Detector	Height (cm)	degree (deg)	Remark
1	2483.500	44.08	-2.31	41.77	54.00	-12.23	AVG			
2	2484.750	44.06	-2.30	41.76	54.00	-12.24	AVG			

Anbotek

Test Mode: 802.11g
2412MHz
Horizontal-PEAK:

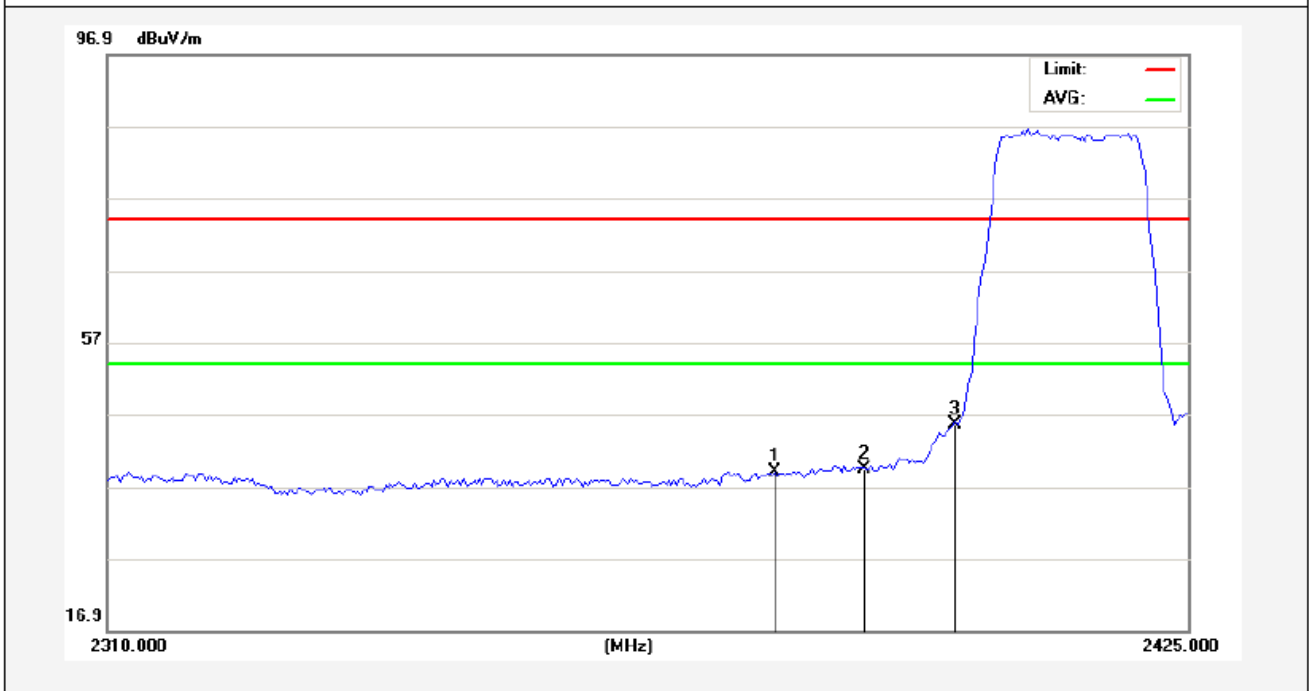

No.	Freq. (MHz)	Reading (dBuV/m)	Factor (dB/m)	Result (dBuV/m)	Limit (dBuV/)	Over Limit (dB)	Detector	Height (cm)	degree (deg)	Remark
1	2380.438	41.52	-2.54	38.98	74.00	-35.02	peak			
2	2390.000	41.86	-2.51	39.35	74.00	-34.65	peak			
3	2400.000	48.16	-2.49	45.67	74.00	-28.33	peak			

Anbotek

Horizontal-AV:

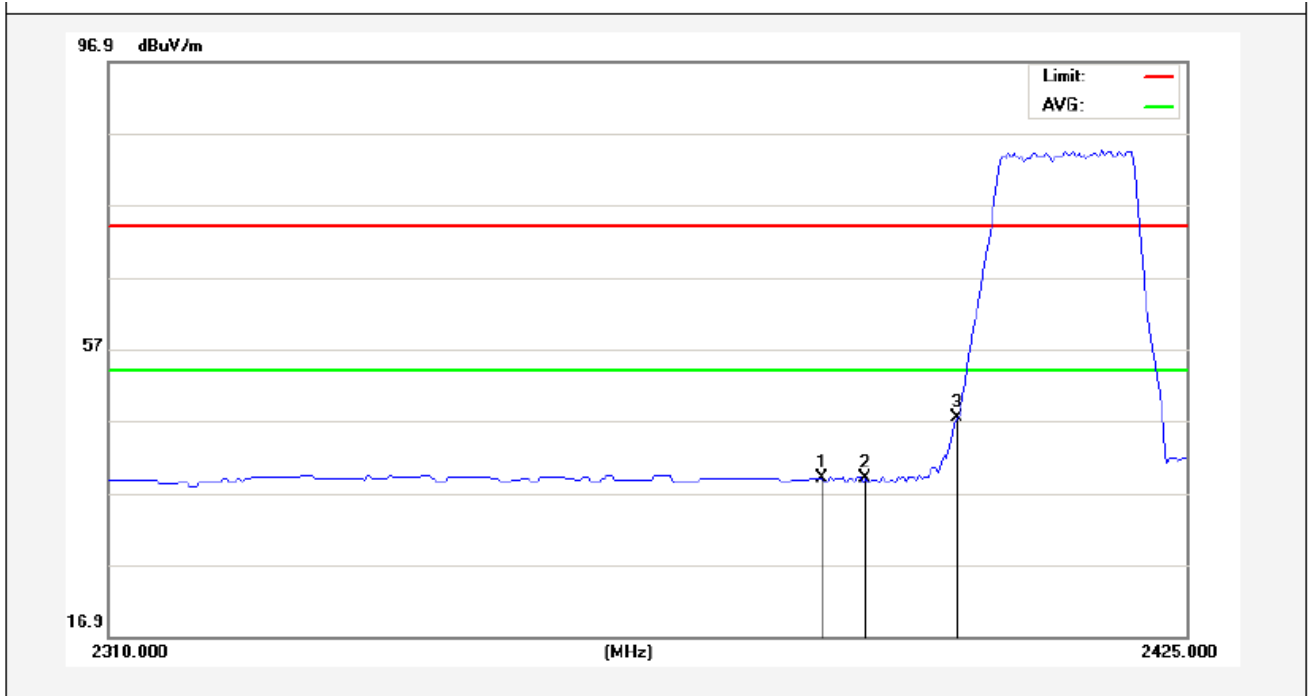

No.	Freq. (MHz)	Reading (dBuV/m)	Factor (dB/m)	Result (dBuV/m)	Limit (dBuV/)	Over Limit (dB)	Detector	Height (cm)	degree (deg)	Remark
1	2385.325	41.53	-2.52	39.01	54.00	-14.99	AVG			
2	2390.000	41.43	-2.51	38.92	54.00	-15.08	AVG			
3	2400.000	49.91	-2.49	47.42	54.00	-6.58	AVG			

Anbotek

Test Mode: 802.11g
2412MHz
Vertical-PEAK:

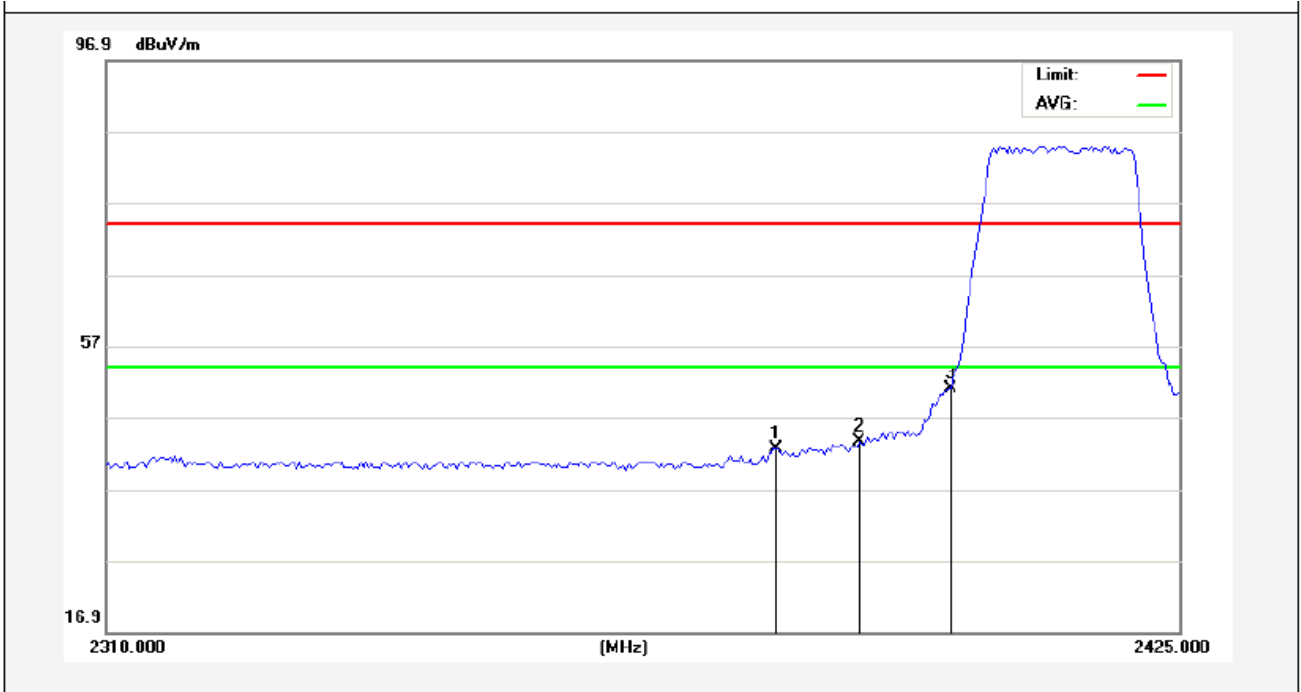

No.	Freq. (MHz)	Reading (dBuV/m)	Factor (dB/m)	Result (dBuV/m)	Limit (dBuV/)	Over Limit (dB)	Detector	Height (cm)	degree (deg)	Remark
1	2381.300	45.23	-2.53	42.70	74.00	-31.30	peak			
2	2390.000	46.05	-2.51	43.54	74.00	-30.46	peak			
3	2400.000	53.49	-2.49	51.00	74.00	-23.00	peak			

Anbotek

Vertical-AV:

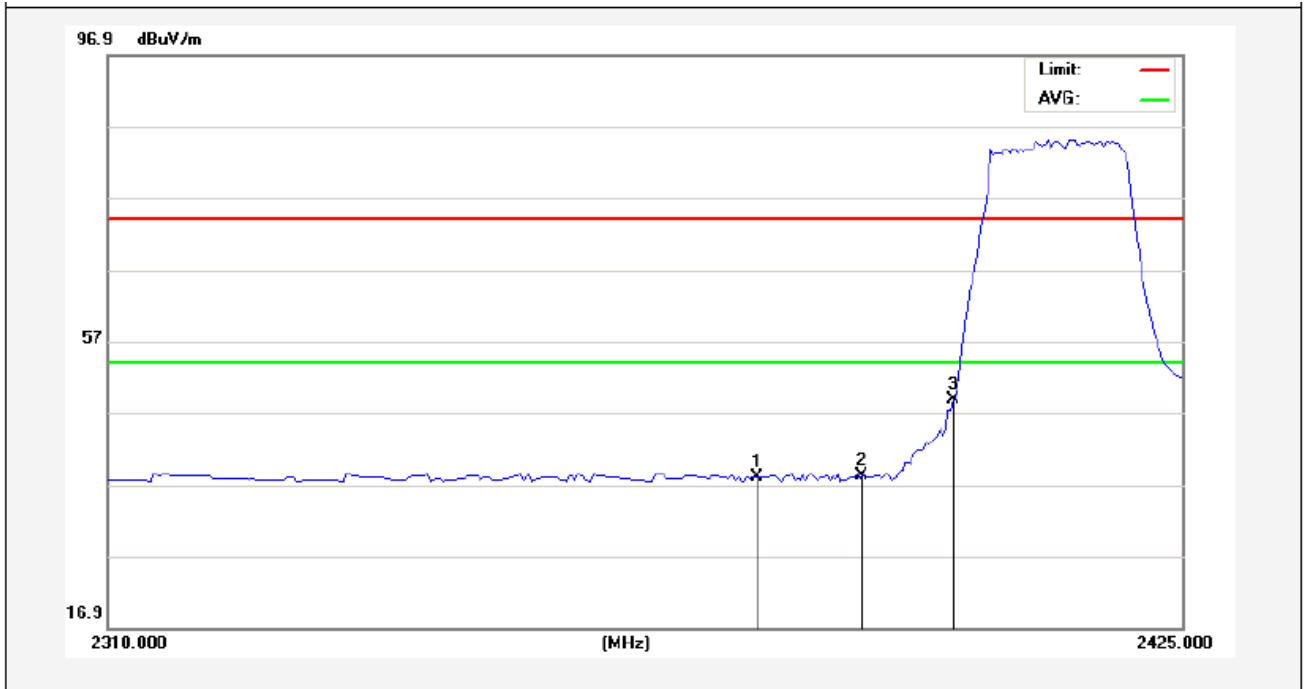

No.	Freq. (MHz)	Reading (dBuV/m)	Factor (dB/m)	Result (dBuV/m)	Limit (dBuV/)	Over Limit (dB)	Detector	Height (cm)	degree (deg)	Remark
1	2379.000	40.52	-2.54	37.98	54.00	-16.02	AVG			
2	2390.000	40.68	-2.51	38.17	54.00	-15.83	AVG			
3	2400.000	51.29	-2.49	48.80	54.00	-5.20	AVG			

Anbotek

Test Mode: 802.11g
2462MHz
Horizontal-PEAK:

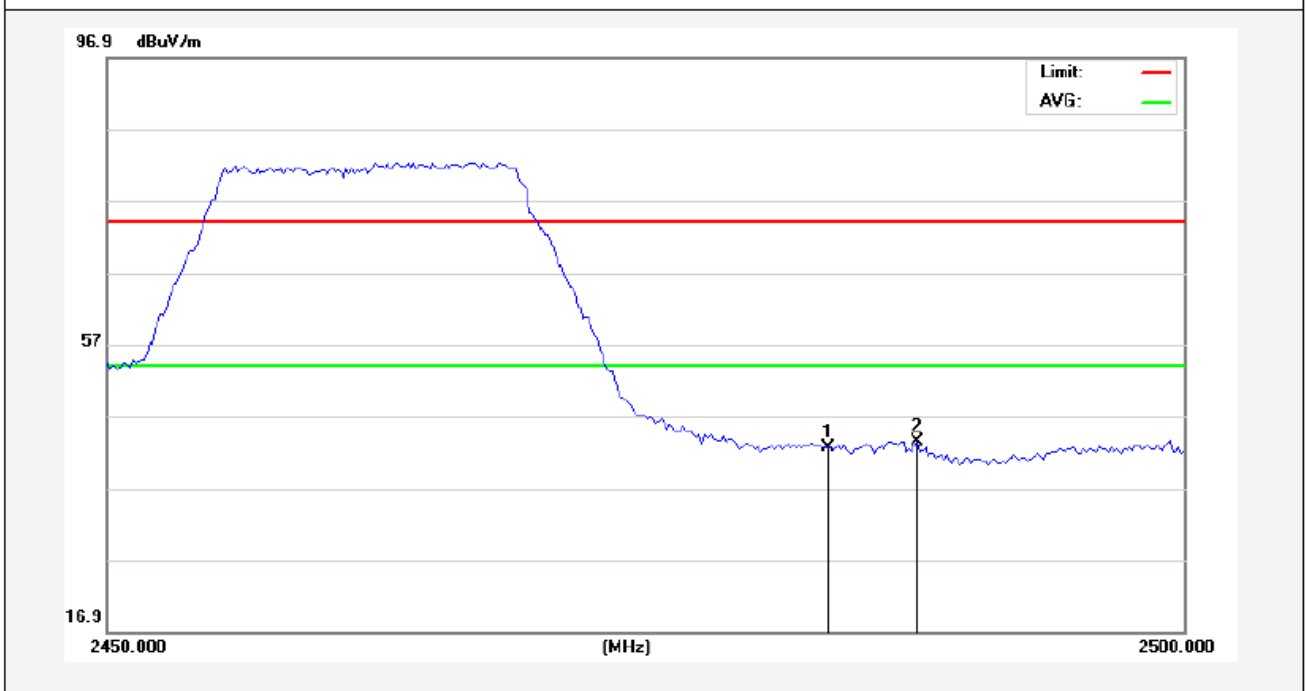

No.	Freq. (MHz)	Reading (dBuV/m)	Factor (dB/m)	Result (dBuV/m)	Limit (dBuV/)	Over Limit (dB)	Detector	Height (cm)	degree (deg)	Remark
1	2483.500	44.94	-2.31	42.63	74.00	-31.37	peak			
2	2487.625	45.69	-2.30	43.39	74.00	-30.61	peak			

Anbotek

Horizontal-AV:

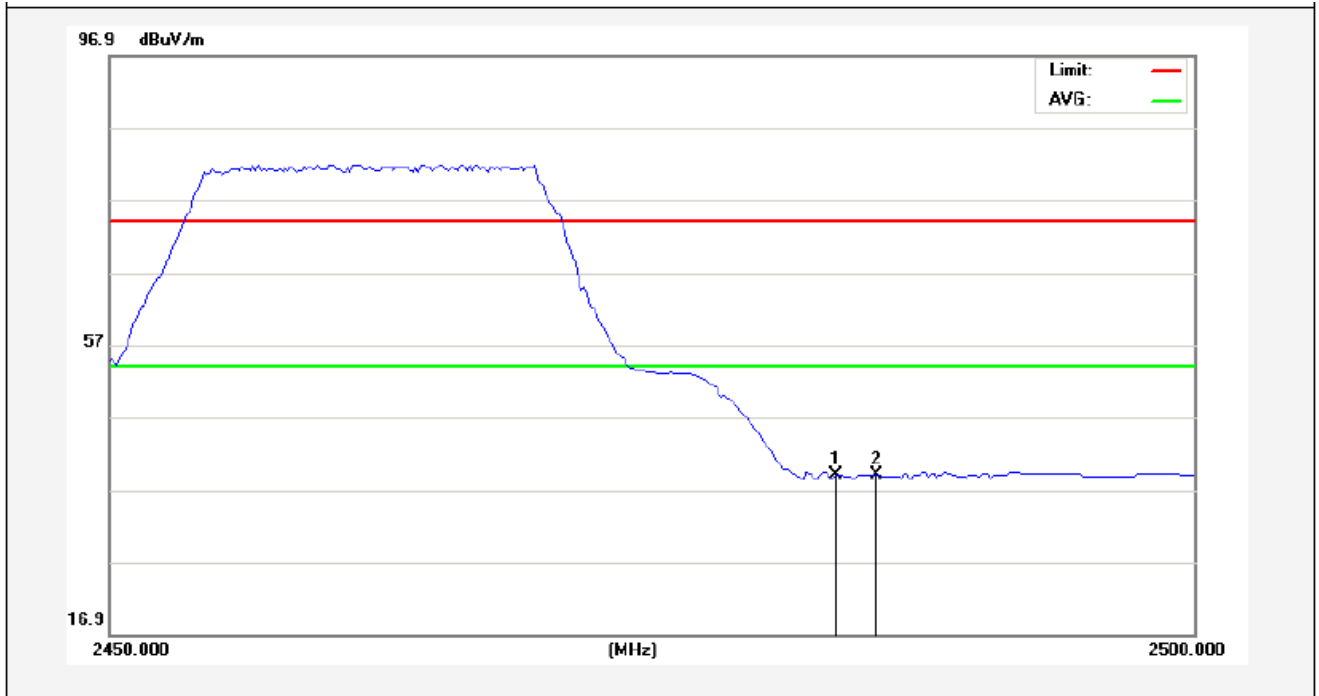

No.	Freq. (MHz)	Reading (dBuV/m)	Factor (dB/m)	Result (dBuV/m)	Limit (dBuV/)	Over Limit (dB)	Detector	Height (cm)	degree (deg)	Remark
1	2483.500	41.38	-2.31	39.07	54.00	-14.93	AVG			
2	2485.375	41.22	-2.30	38.92	54.00	-15.08	AVG			

Anbotek

Test Mode: 802.11g
2462MHz
Vertical-PEAK:

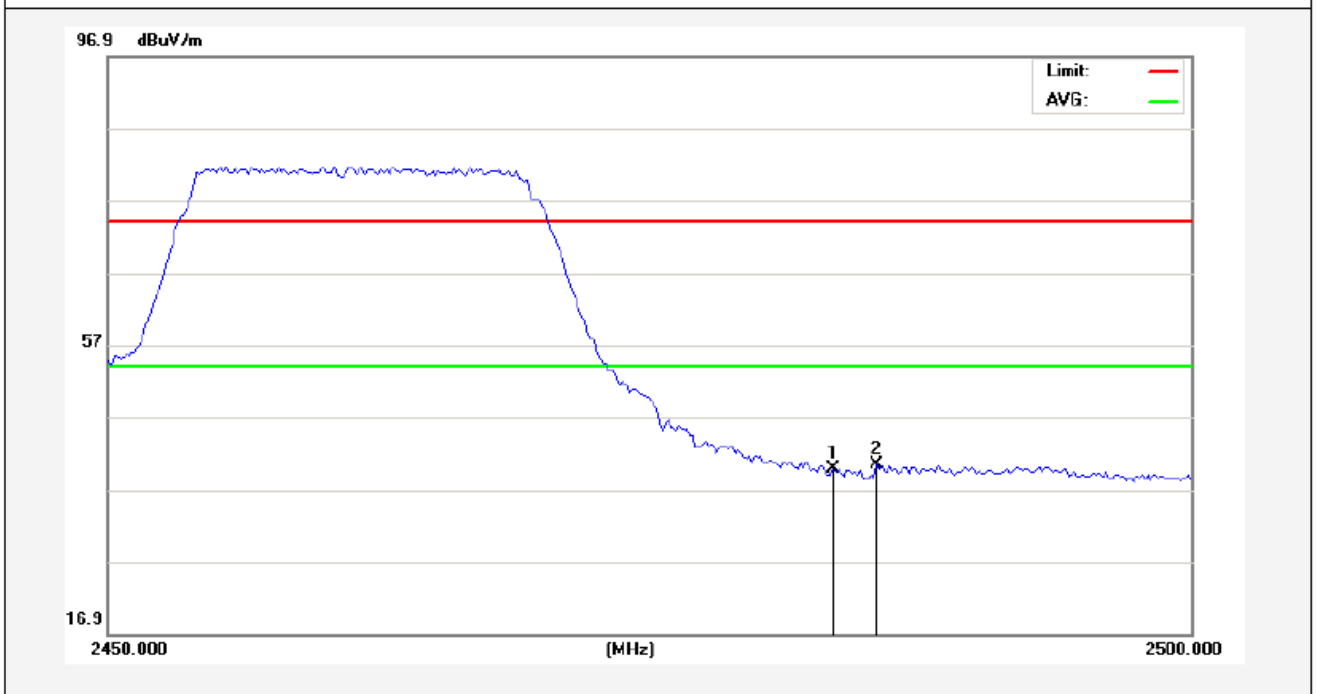

No.	Freq. (MHz)	Reading (dBuV/m)	Factor (dB/m)	Result (dBuV/m)	Limit (dBuV/)	Over Limit (dB)	Detector	Height (cm)	degree (deg)	Remark
1	2483.500	42.07	-2.31	39.76	74.00	-34.24	peak			
2	2485.500	42.64	-2.30	40.34	74.00	-33.66	peak			

Anbotek

Vertical-AV:

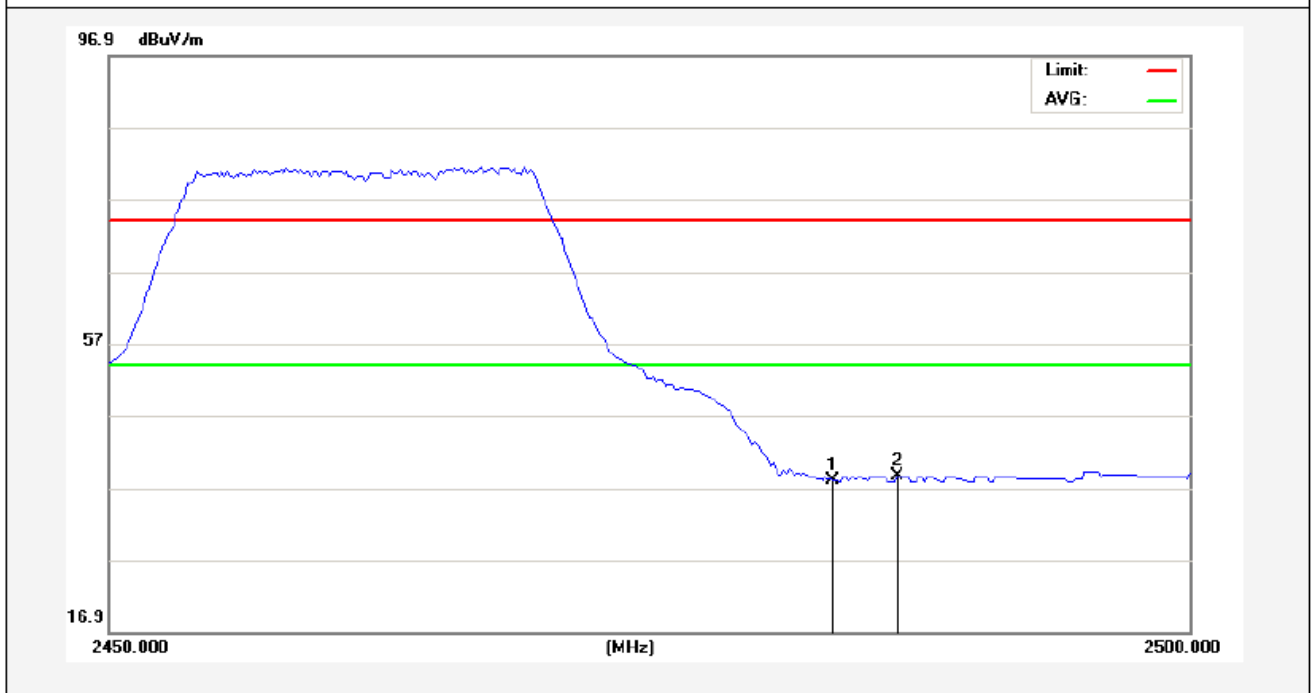

No.	Freq. (MHz)	Reading (dBuV/m)	Factor (dB/m)	Result (dBuV/m)	Limit (dBuV/)	Over Limit (dB)	Detector	Height (cm)	degree (deg)	Remark
1	2483.500	40.38	-2.31	38.07	54.00	-15.93	AVG			
2	2486.500	40.99	-2.30	38.69	54.00	-15.31	AVG			

Anbotek

Test Mode: 802.11n (HT20)

2412MHz

Horizontal-PEAK:

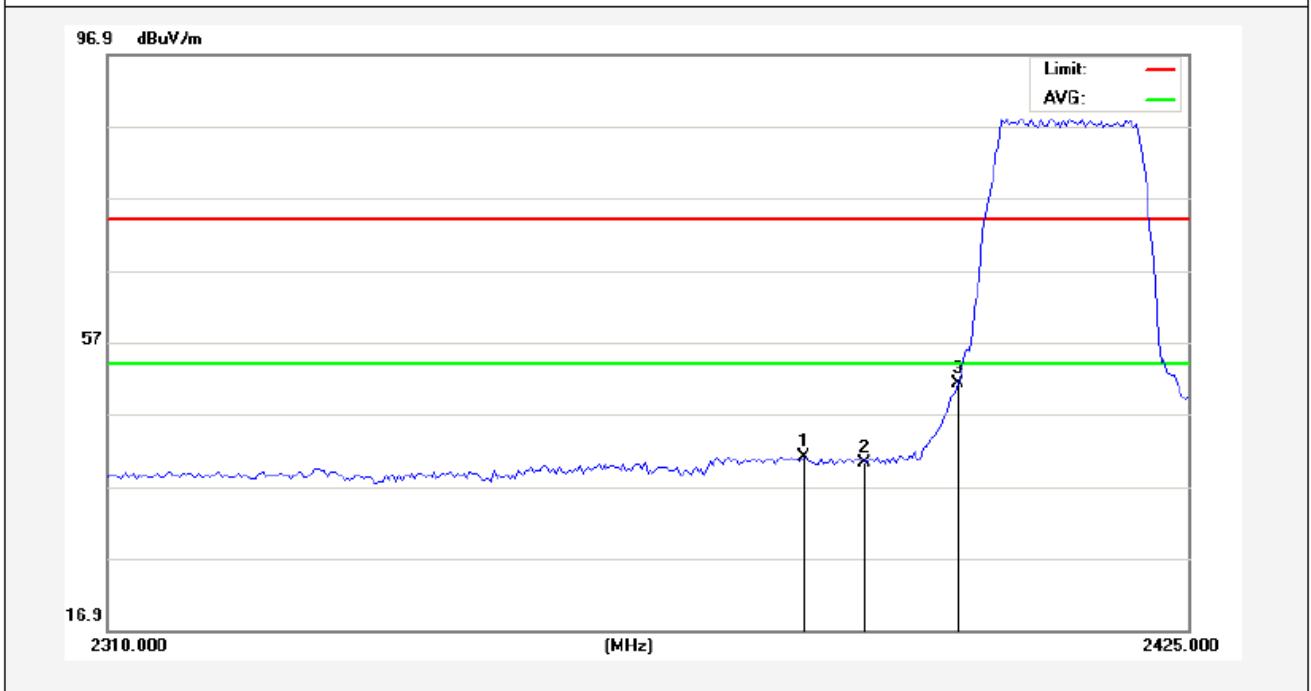

No.	Freq. (MHz)	Reading (dBuV/m)	Factor (dB/m)	Result (dBuV/m)	Limit (dBuV/)	Over Limit (dB)	Detector	Height (cm)	degree (deg)	Remark
1	2383.600	43.44	-2.53	40.91	74.00	-33.09	peak			
2	2390.000	42.63	-2.51	40.12	74.00	-33.88	peak			
3	2400.000	53.75	-2.49	51.26	74.00	-22.74	peak			

Anbotek

Horizontal-AV:

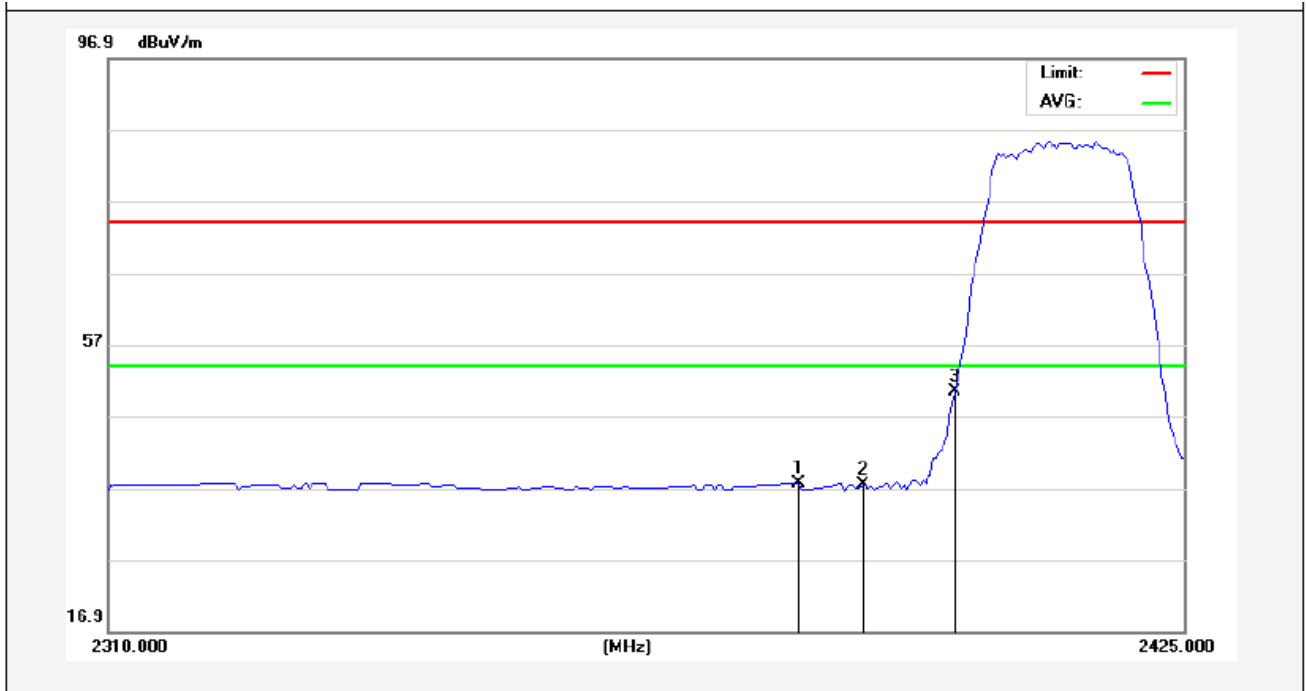

No.	Freq. (MHz)	Reading (dBuV/m)	Factor (dB/m)	Result (dBuV/m)	Limit (dBuV/)	Over Limit (dB)	Detector	Height (cm)	degree (deg)	Remark
1	2383.313	40.22	-2.53	37.69	54.00	-16.31	AVG			
2	2390.000	39.83	-2.51	37.32	54.00	-16.68	AVG			
3	2400.000	52.89	-2.49	50.40	54.00	-3.60	AVG			

Anbotek

Test Mode: 802.11n (HT20)

2412MHz

Vertical-PEAK:

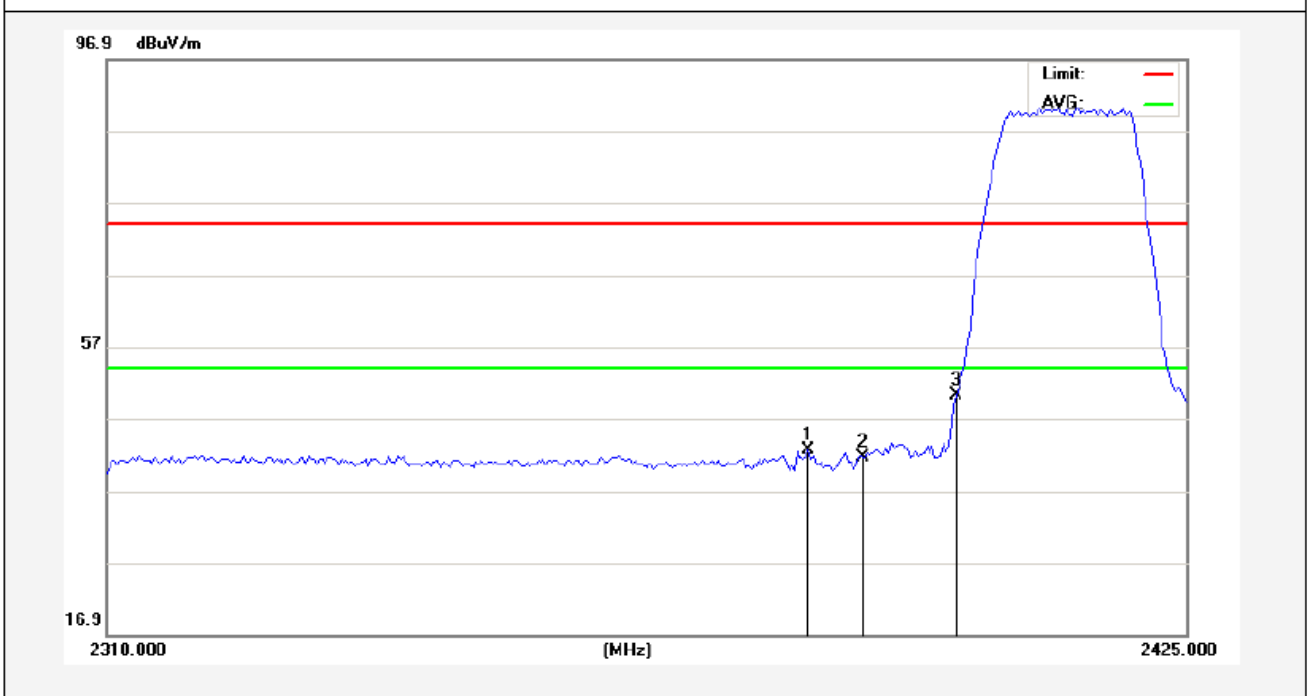

No.	Freq. (MHz)	Reading (dBuV/m)	Factor (dB/m)	Result (dBuV/m)	Limit (dBuV/)	Over Limit (dB)	Detector	Height (cm)	degree (deg)	Remark
1	2384.175	45.13	-2.53	42.60	74.00	-31.40	peak			
2	2390.000	44.13	-2.51	41.62	74.00	-32.38	peak			
3	2400.000	52.73	-2.49	50.24	74.00	-23.76	peak			

Anbotek

Vertical-AV:

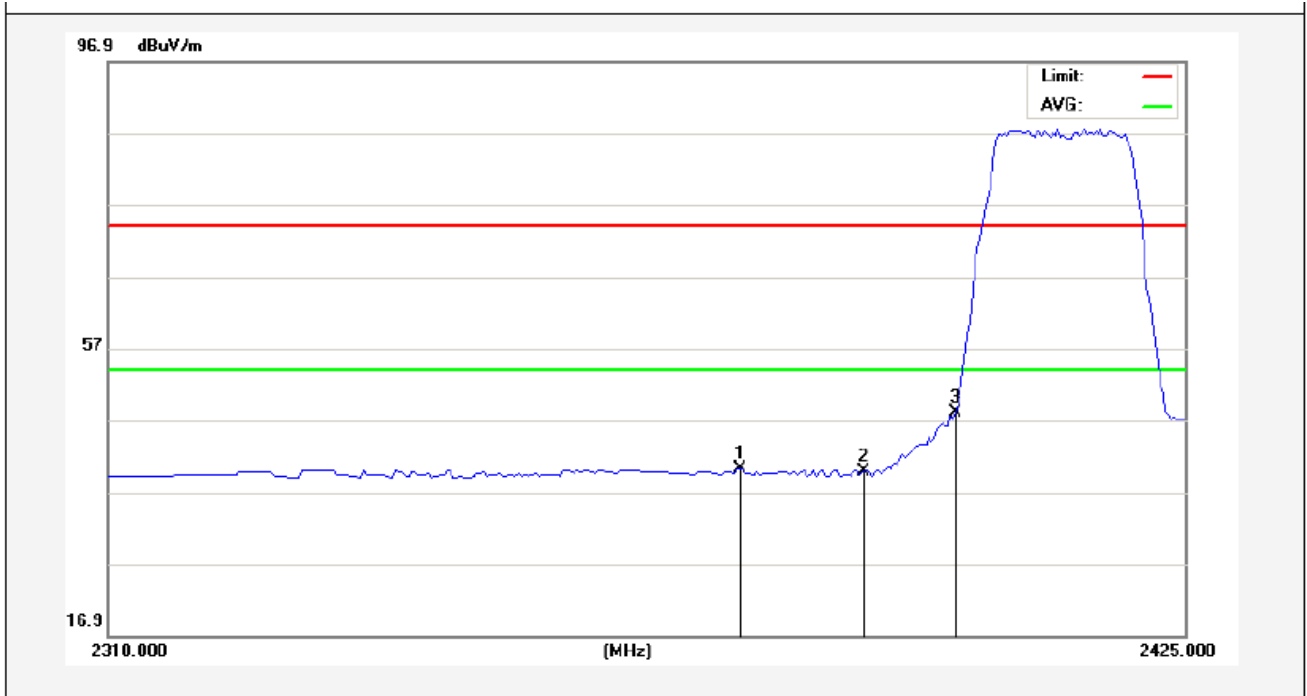

No.	Freq. (MHz)	Reading (dBuV/m)	Factor (dB/m)	Result (dBuV/m)	Limit (dBuV/)	Over Limit (dB)	Detector	Height (cm)	degree (deg)	Remark
1	2376.988	42.66	-2.54	40.12	54.00	-13.88	AVG			
2	2390.000	42.30	-2.51	39.79	54.00	-14.21	AVG			
3	2400.000	50.50	-2.49	48.01	54.00	-5.99	AVG			

Anbotek

Test Mode: 802.11n (HT20)

2462MHz

Horizontal-PEAK:

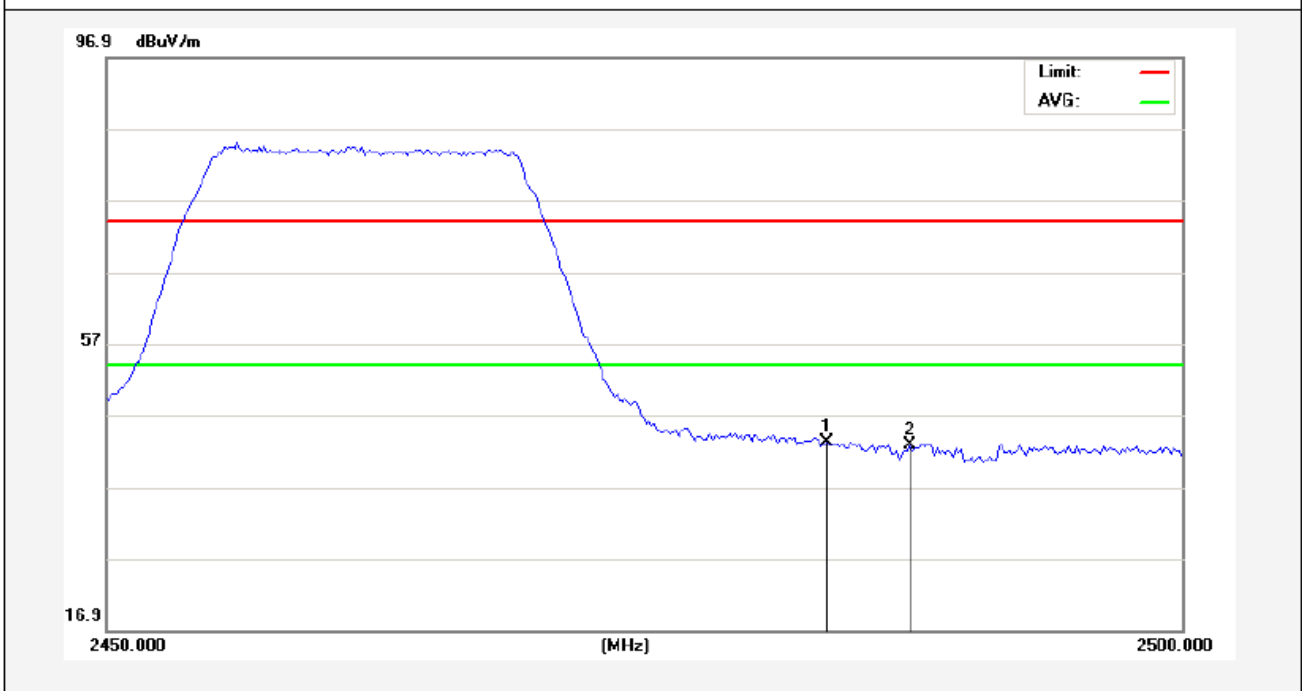

No.	Freq. (MHz)	Reading (dBuV/m)	Factor (dB/m)	Result (dBuV/m)	Limit (dBuV/)	Over Limit (dB)	Detector	Height (cm)	degree (deg)	Remark
1	2483.500	45.59	-2.31	43.28	74.00	-30.72	peak			
2	2487.375	45.06	-2.30	42.76	74.00	-31.24	peak			

Anbotek

Horizontal-AV:

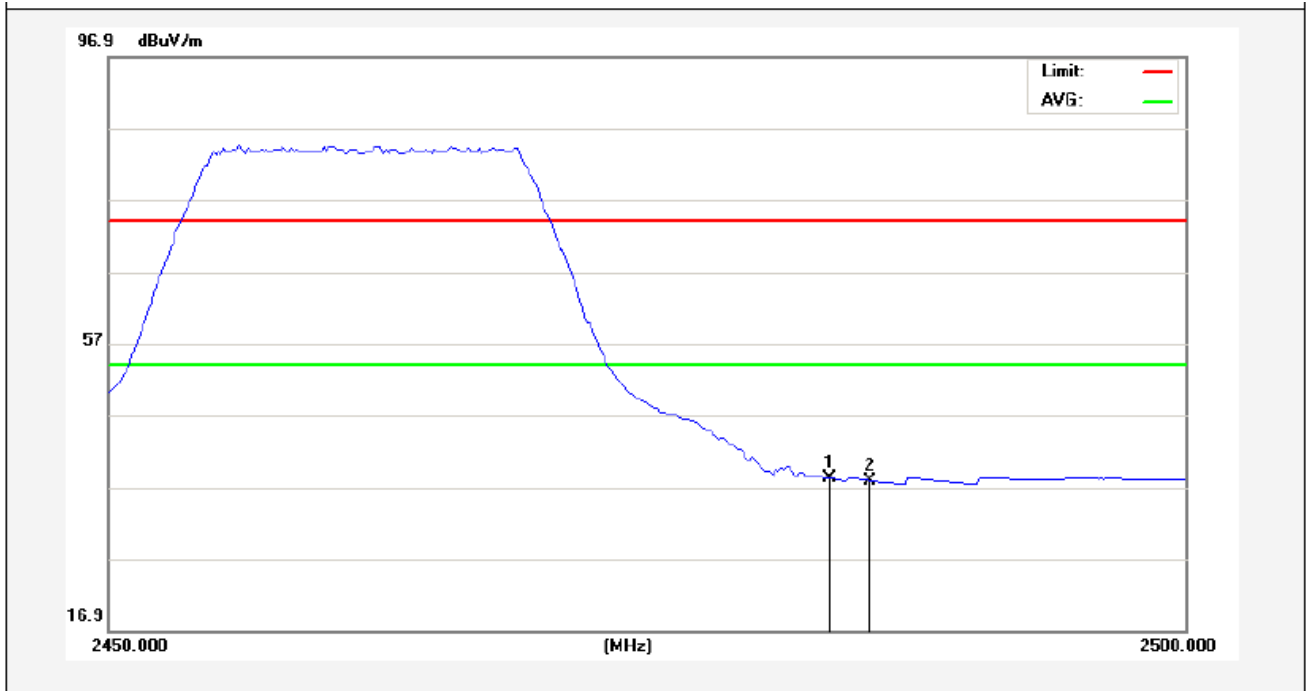

No.	Freq. (MHz)	Reading (dBuV/m)	Factor (dB/m)	Result (dBuV/m)	Limit (dBuV/)	Over Limit (dB)	Detector	Height (cm)	degree (deg)	Remark
1	2483.500	40.47	-2.31	38.16	54.00	-15.84	AVG			
2	2485.375	40.18	-2.30	37.88	54.00	-16.12	AVG			

Anbotek

Test Mode: 802.11n (HT20)

2462MHz

Vertical-PEAK:

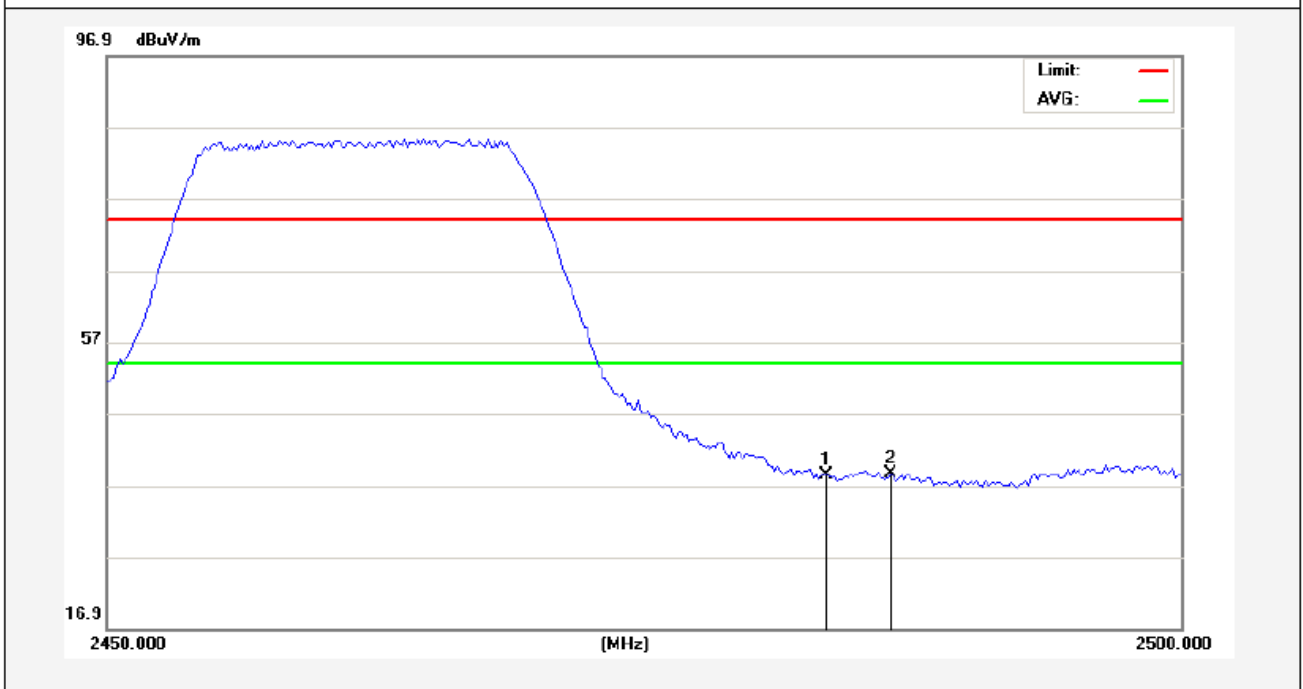

No.	Freq. (MHz)	Reading (dBuV/m)	Factor (dB/m)	Result (dBuV/m)	Limit (dBuV/)	Over Limit (dB)	Detector	Height (cm)	degree (deg)	Remark
1	2483.500	40.62	-2.31	38.31	74.00	-35.69	peak			
2	2486.500	40.86	-2.30	38.56	74.00	-35.44	peak			

Anbotek

Vertical-AV:

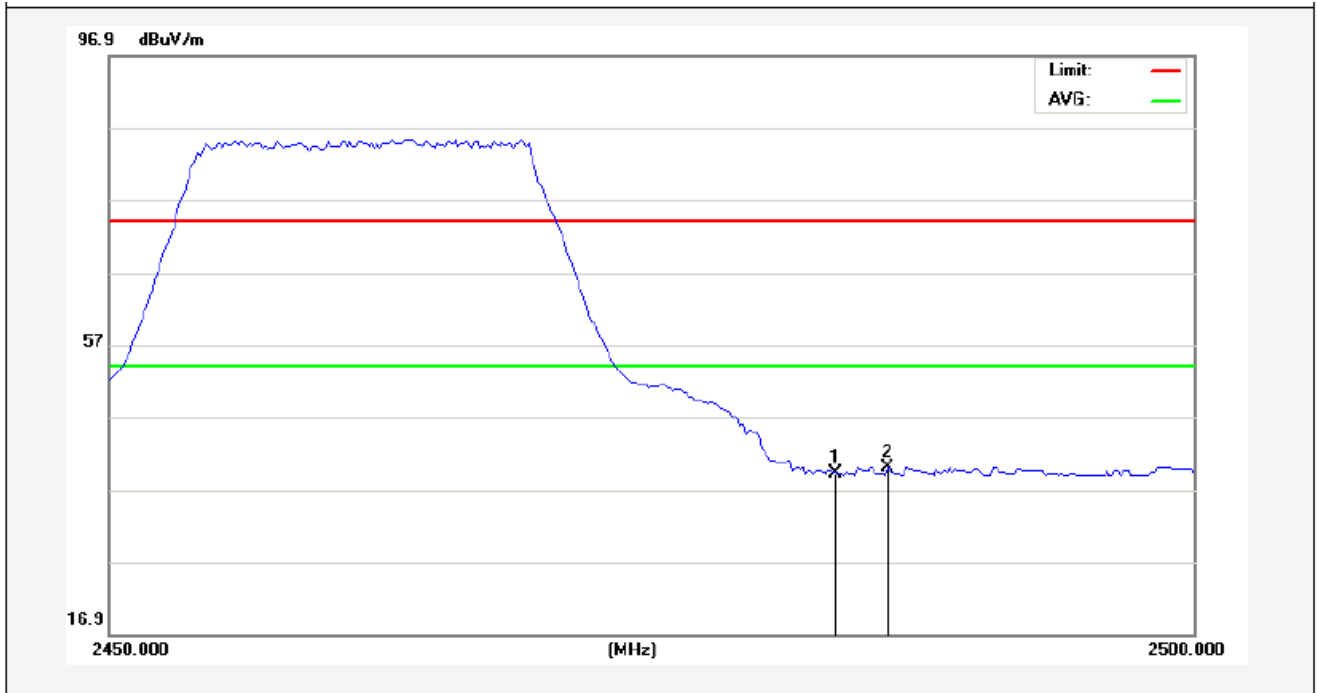

No.	Freq. (MHz)	Reading (dBuV/m)	Factor (dB/m)	Result (dBuV/m)	Limit (dBuV/)	Over Limit (dB)	Detector	Height (cm)	degree (deg)	Remark
1	2483.500	41.61	-2.31	39.30	54.00	-14.70	AVG			
2	2485.875	42.29	-2.30	39.99	54.00	-14.01	AVG			

Anbotek

Test Mode: 802.11n (HT40)

2422MHz

Horizontal-PEAK:

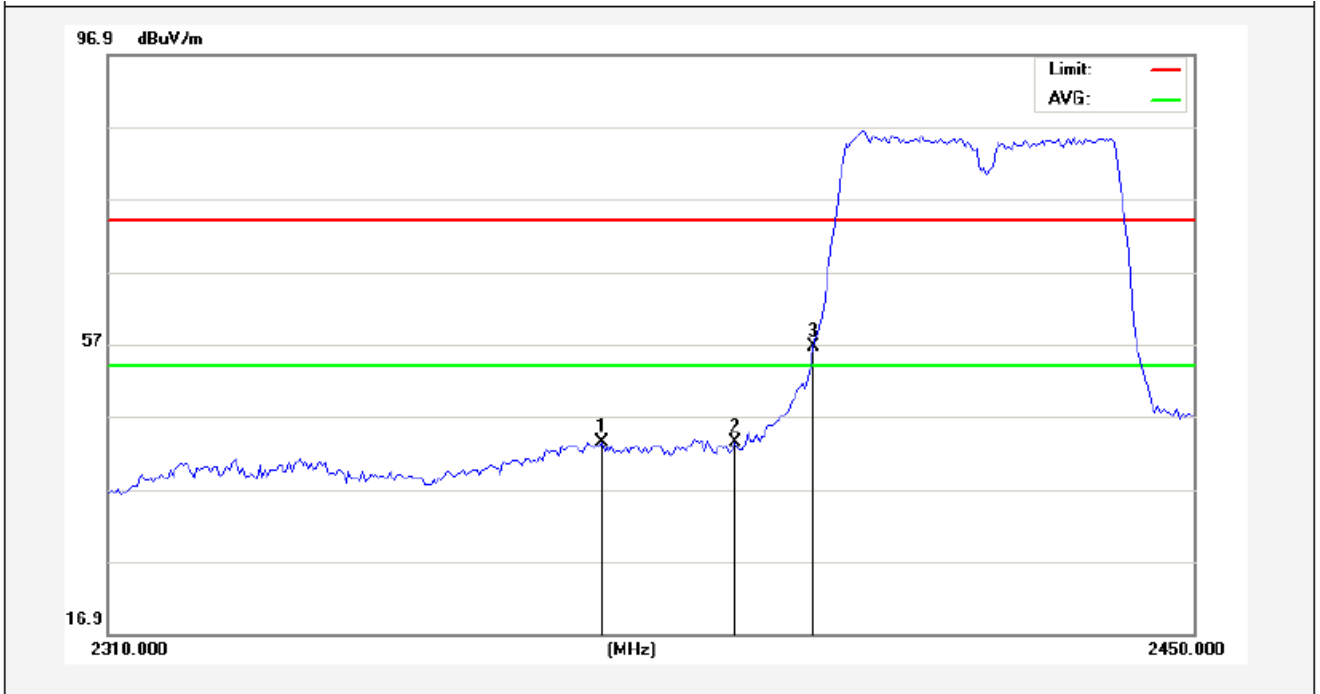

No.	Freq. (MHz)	Reading (dBuV/m)	Factor (dB/m)	Result (dBuV/m)	Limit (dBuV/)	Over Limit (dB)	Detector	Height (cm)	degree (deg)	Remark
1	2373.000	45.93	-2.55	43.38	74.00	-30.62	peak			
2	2390.000	46.01	-2.51	43.50	74.00	-30.50	peak			
3	2400.000	59.01	-2.49	56.52	74.00	-17.48	peak			

Anbotek

Horizontal-AV:

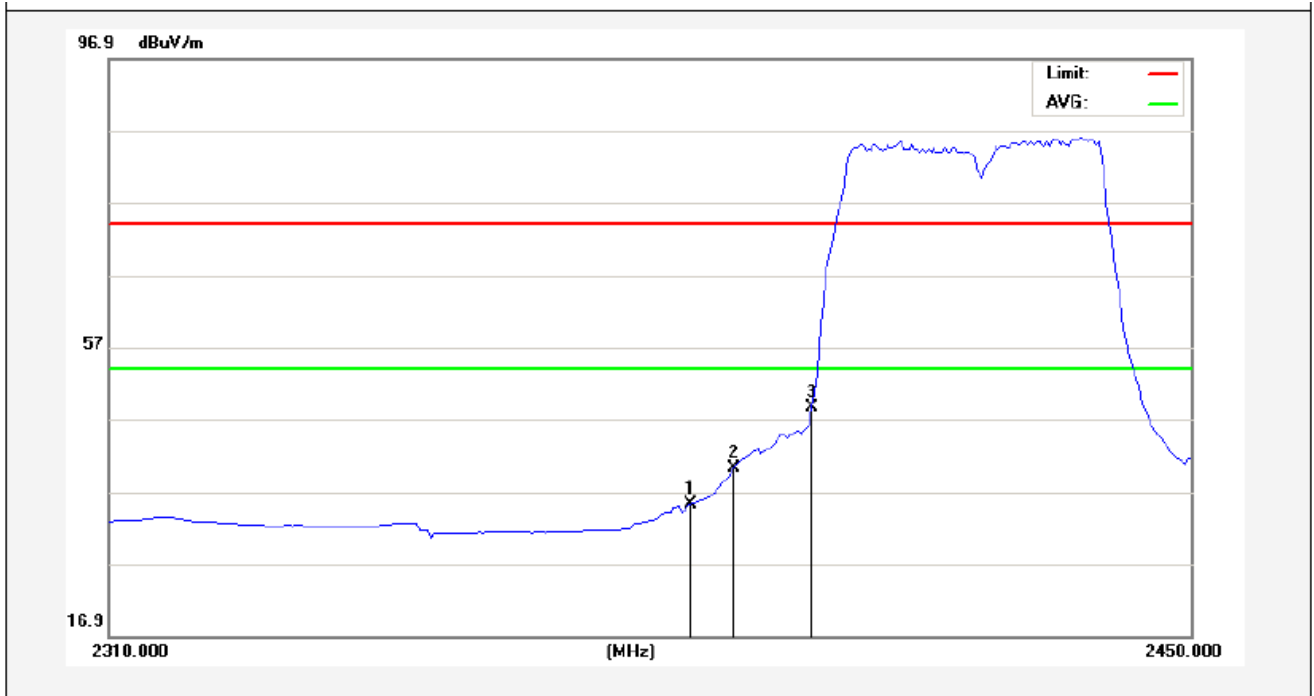

No.	Freq. (MHz)	Reading (dBuV/m)	Factor (dB/m)	Result (dBuV/m)	Limit (dBuV/)	Over Limit (dB)	Detector	Height (cm)	degree (deg)	Remark
1	2384.550	37.67	-2.53	35.14	54.00	-18.86	AVG			
2	2390.000	42.65	-2.51	40.14	54.00	-13.86	AVG			
3	2400.000	51.14	-2.49	48.65	54.00	-5.35	AVG			

Anbotek

Test Mode: 802.11n (HT40)

2422MHz

Vertical-PEAK:

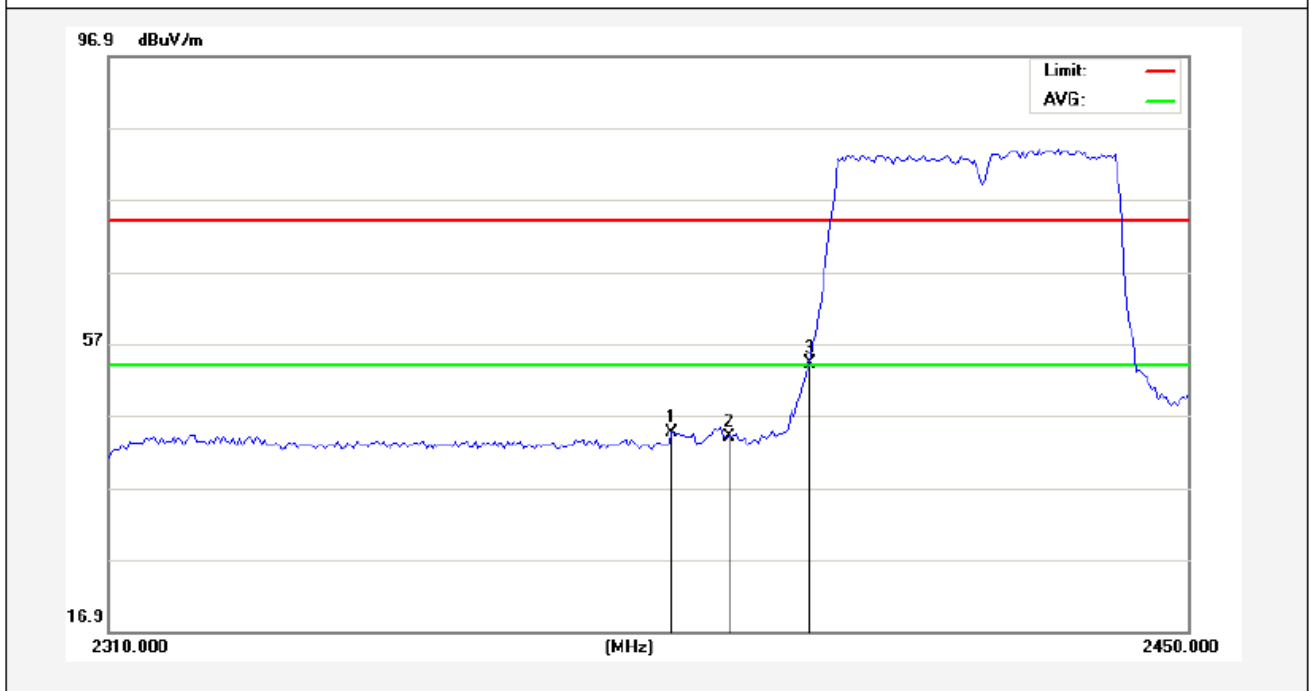

No.	Freq. (MHz)	Reading (dBuV/m)	Factor (dB/m)	Result (dBuV/m)	Limit (dBuV/)	Over Limit (dB)	Detector	Height (cm)	degree (deg)	Remark
1	2382.450	47.08	-2.53	44.55	74.00	-29.45	peak			
2	2390.000	46.46	-2.51	43.95	74.00	-30.05	peak			
3	2400.000	56.72	-2.49	54.23	74.00	-19.77	peak			

Anbotek

Vertical-AV:

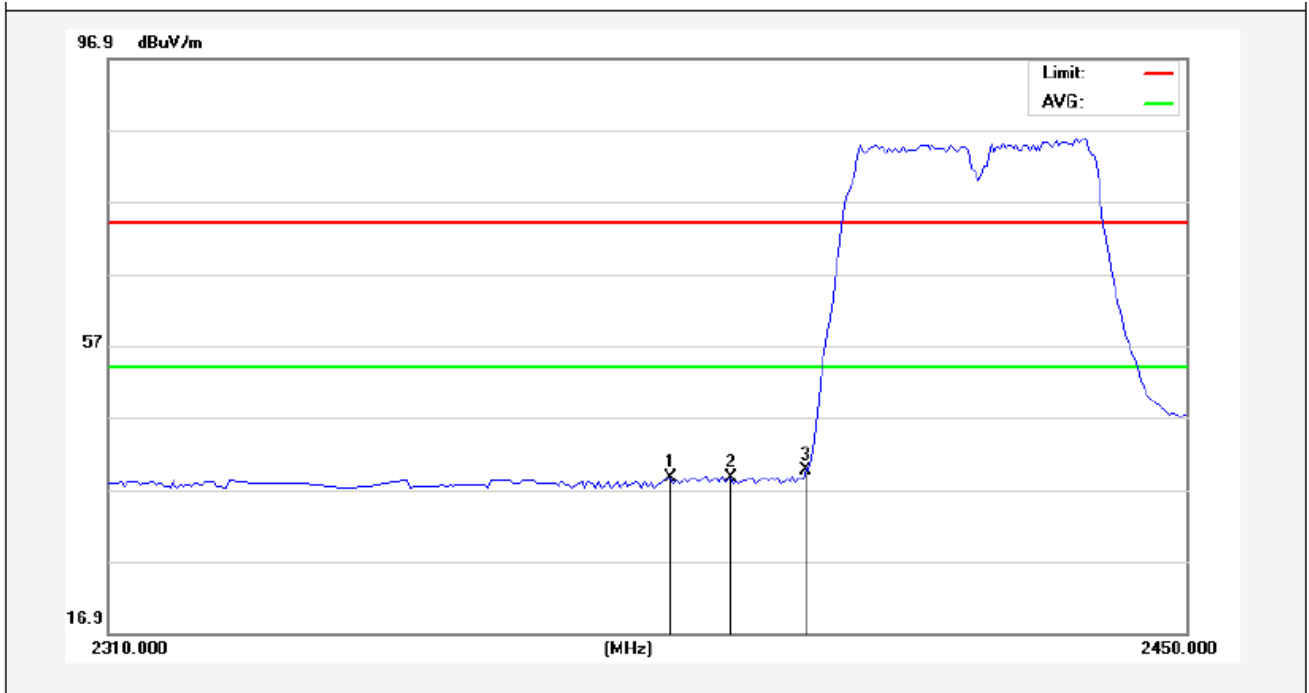

No.	Freq. (MHz)	Reading (dBuV/m)	Factor (dB/m)	Result (dBuV/m)	Limit (dBuV/)	Over Limit (dB)	Detector	Height (cm)	degree (deg)	Remark
1	2382.450	41.12	-2.53	38.59	54.00	-15.41	AVG			
2	2390.000	41.14	-2.51	38.63	54.00	-15.37	AVG			
3	2400.000	42.16	-2.49	39.67	54.00	-14.33	AVG			

Anbotek

Test Mode: 802.11n (HT40)

2452MHz

Horizontal-PEAK:

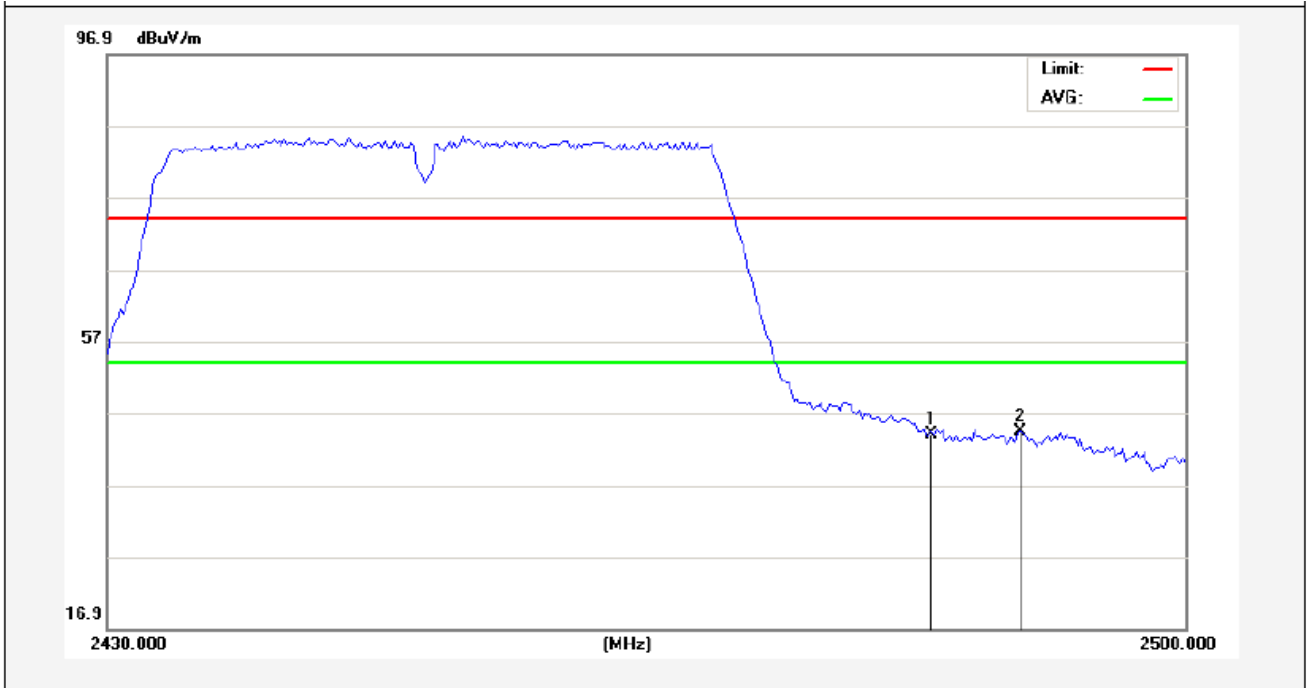

No.	Freq. (MHz)	Reading (dBuV/m)	Factor (dB/m)	Result (dBuV/m)	Limit (dBuV/)	Over Limit (dB)	Detector	Height (cm)	degree (deg)	Remark
1	2483.500	46.23	-2.31	43.92	74.00	-30.08	peak			
2	2489.325	46.77	-2.29	44.48	74.00	-29.52	peak			

Anbotek

Horizontal-AV:

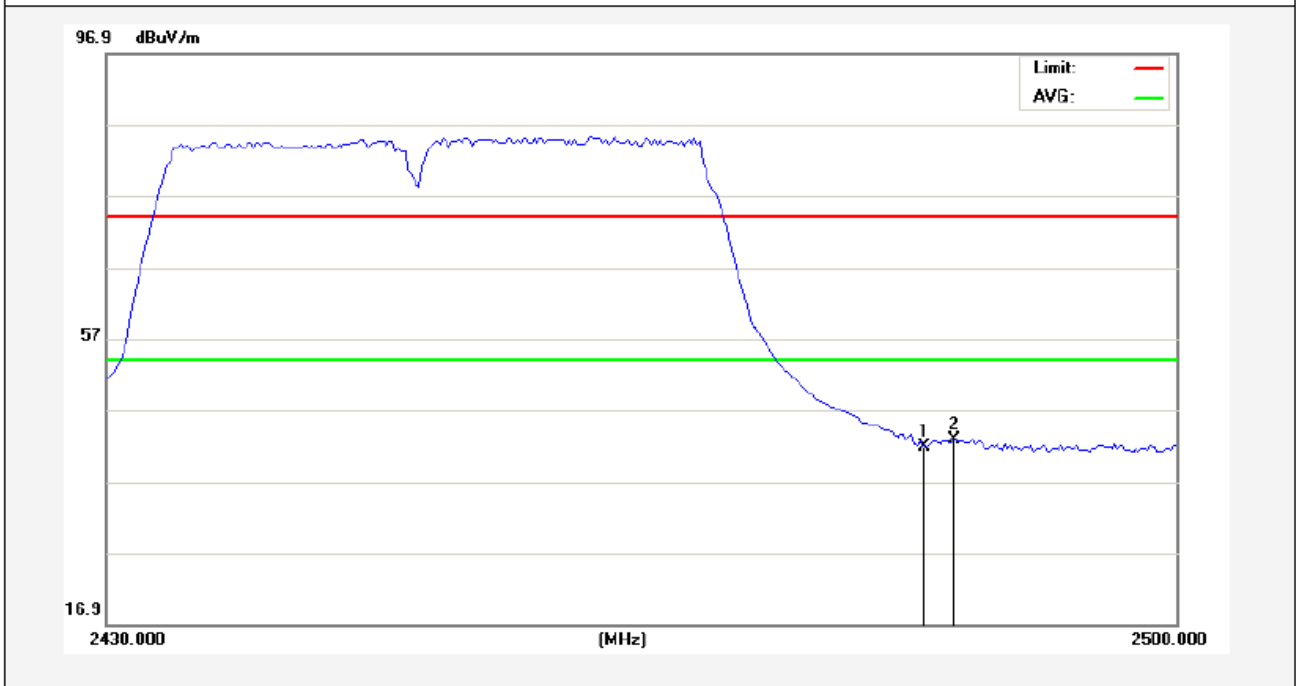

No.	Freq. (MHz)	Reading (dBuV/m)	Factor (dB/m)	Result (dBuV/m)	Limit (dBuV/)	Over Limit (dB)	Detector	Height (cm)	degree (deg)	Remark
1	2483.500	44.20	-2.31	41.89	54.00	-12.11	AVG			
2	2485.475	45.08	-2.30	42.78	54.00	-11.22	AVG			

Anbotek

Test Mode: 802.11n (HT40)

2452MHz

Vertical-PEAK:

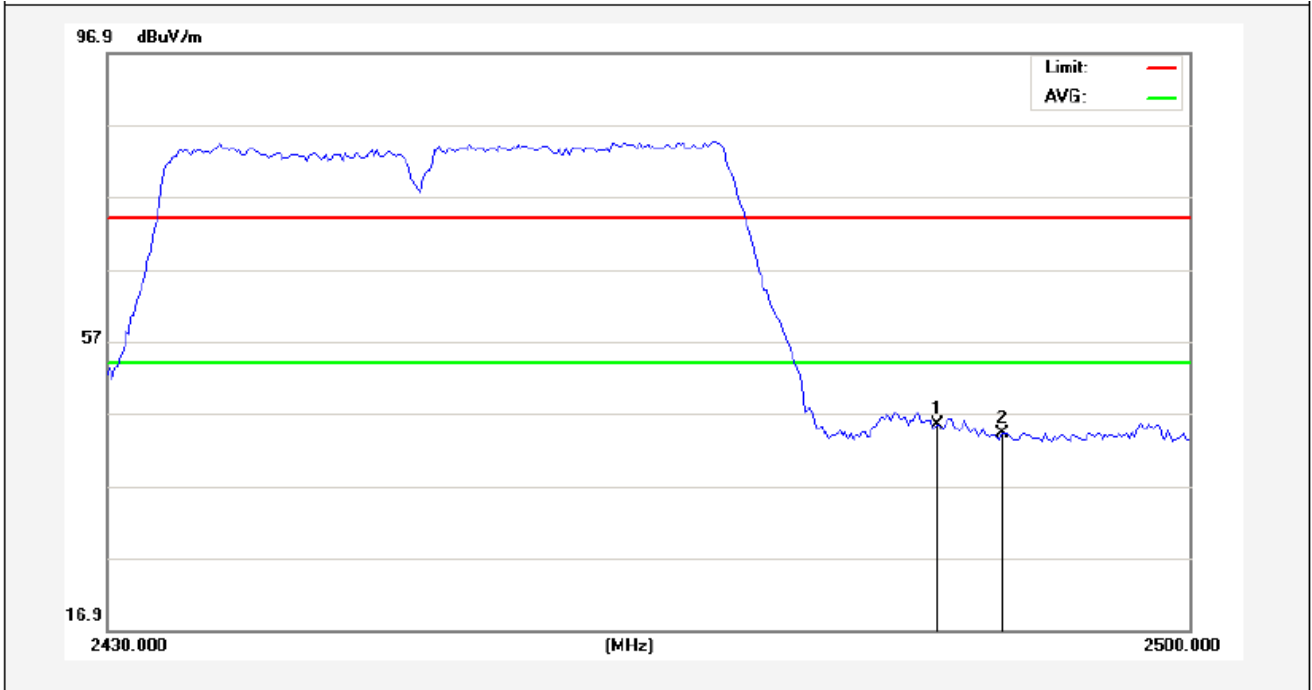

No.	Freq. (MHz)	Reading (dBuV/m)	Factor (dB/m)	Result (dBuV/m)	Limit (dBuV/)	Over Limit (dB)	Detector	Height (cm)	degree (deg)	Remark
1	2483.500	47.81	-2.31	45.50	74.00	-28.50	peak			
2	2487.925	46.51	-2.30	44.21	74.00	-29.79	peak			

Anbotek

Vertical-AV:

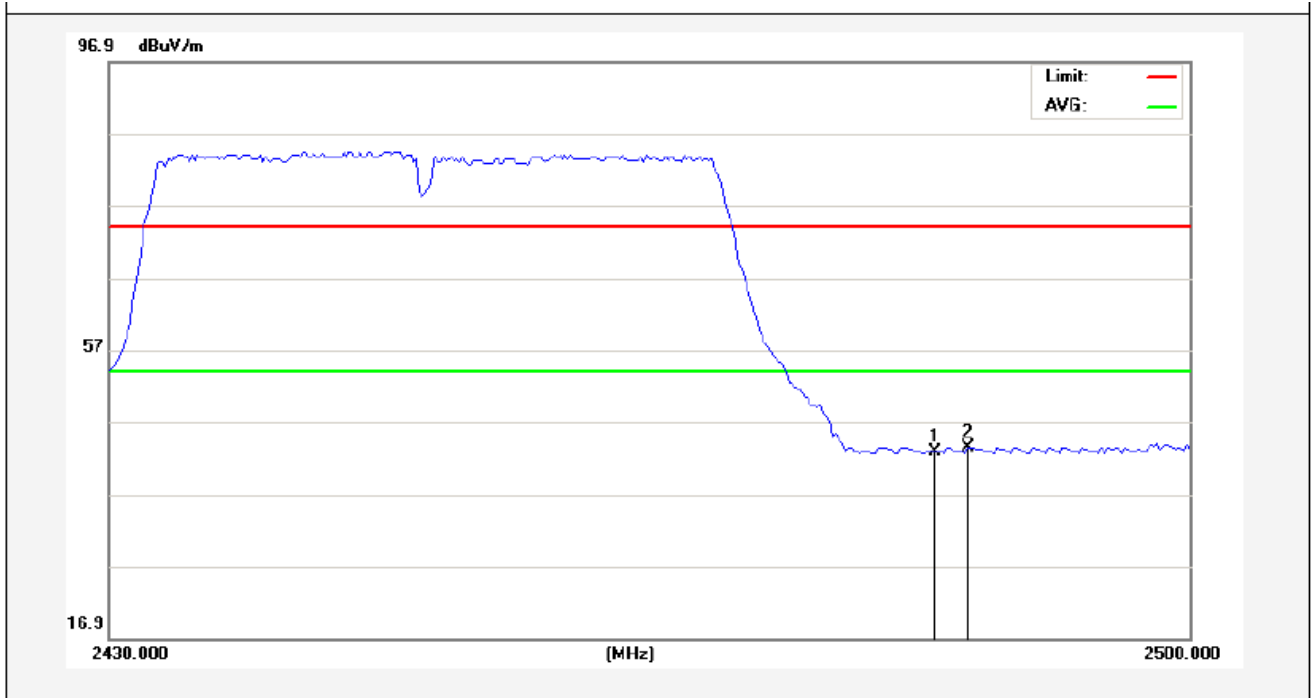

No.	Freq. (MHz)	Reading (dBuV/m)	Factor (dB/m)	Result (dBuV/m)	Limit (dBuV/)	Over Limit (dB)	Detector	Height (cm)	degree (deg)	Remark
1	2483.500	45.10	-2.31	42.79	54.00	-11.21	AVG			
2	2485.650	45.80	-2.30	43.50	54.00	-10.50	AVG			

Anbotek