



FCC PART 27

FCC PART 22H, PART 24E

TEST REPORT

For

INFINIX MOBILITY LIMITED

FLAT 39 8/F BLOCK D WAH LOK INDUSTRIAL CENTRE 31-35 SHAN MEI STREET
FOTAN NT, Hong Kong

FCC ID: 2AIZN-X688C

Report Type: Original Report	Product Type: Mobile Phone
Report Number: RSZ201102004-00D	
Report Date: 2020-12-02	
Reviewed By: RF Engineer	Nancy Wang 
Prepared By: Bay Area Compliance Laboratories Corp. (Shenzhen) 6/F., West Wing, Third Phase of Wanli Industrial Building, Shihua Road, Futian Free Trade Zone, Shenzhen, Guangdong, China Tel: +86-755-33320018 Fax: +86-755-33320008 www.baclcorp.com.cn	

Note: This report may contain data that are not covered by the A2LA accreditation and are marked with an asterisk "★".

BACL is not responsible for the authenticity of any test data provided by the applicant. Data included from the applicant that may affect test results are marked with an asterisk '*'. Customer model name, addresses, names, trademarks etc. are not considered data.

This report cannot be reproduced except in full, without prior written approval of the Company. Unless otherwise stated the results shown in this test report refer only to the sample(s) tested. This report is valid only with a valid digital signature. The digital signature may be available only under the Adobe software above version 7.0.

TABLE OF CONTENTS

GENERAL INFORMATION.....	3
PRODUCT DESCRIPTION FOR EQUIPMENT UNDER TEST (EUT)	3
OBJECTIVE	3
TEST METHODOLOGY	4
MEASUREMENT UNCERTAINTY.....	4
TEST FACILITY	4
SYSTEM TEST CONFIGURATION.....	5
DESCRIPTION OF TEST CONFIGURATION	5
EQUIPMENT MODIFICATIONS	5
SUPPORT EQUIPMENT LIST AND DETAILS	5
SUPPORT CABLE DESCRIPTION	5
BLOCK DIAGRAM OF TEST SETUP	5
SUMMARY OF TEST RESULTS.....	6
TEST EQUIPMENT LIST	7
FCC §1.1307(B) & §2.1093 - RF EXPOSURE INFORMATION.....	9
APPLICABLE STANDARD	9
TEST RESULT	9
FCC §2.1047 - MODULATION CHARACTERISTIC	10
FCC § 2.1046, § 22.913 (A) & § 24.232 (C); §27.50 (C) (D) (H) - RF OUTPUT POWER.....	11
APPLICABLE STANDARD	11
TEST PROCEDURE	11
TEST DATA	11
FCC §2.1049, §22.917, §22.905 & §24.238 & §27.53 - OCCUPIED BANDWIDTH.....	37
APPLICABLE STANDARD	37
TEST PROCEDURE	37
TEST DATA	37
FCC §2.1051, §22.917(A) & §24.238(A); §27.53 - SPURIOUS EMISSIONS AT ANTENNA TERMINALS...163	163
APPLICABLE STANDARD	163
TEST PROCEDURE	163
TEST DATA	163
FCC § 2.1053; § 22.917 (A);§ 24.238 (A); §27.53 SPURIOUS RADIATED EMISSIONS	197
APPLICABLE STANDARD	197
TEST PROCEDURE	197
TEST DATA	197
FCC § 22.917 (A);§ 24.238 (A); §27.53 (H)(M) - BAND EDGES	206
APPLICABLE STANDARD	206
TEST PROCEDURE	206
TEST DATA	206
FCC § 2.1055; § 22.355; § 24.235; §27.54 - FREQUENCY STABILITY	276
APPLICABLE STANDARD	276
TEST PROCEDURE	276
TEST DATA	277

GENERAL INFORMATION

Product Description for Equipment under Test (EUT)

Product	Mobile Phone
Tested Model	X688C
Frequency Range	EGSM 850: 824-849MHz(TX); 869-894MHz(RX) PCS 1900: 1850-1910MHz(TX); 1930-1990MHz(RX) WCDMA Band 2: 1850-1910MHz(TX); 1930-1990MHz(RX) WCDMA Band 4: 1710-1755MHz(TX); 2110-2155MHz(RX) WCDMA Band 5: 824-849MHz(TX); 869-894MHz(RX) LTE Band 2: 1850-1910MHz(TX); 1930-1990MHz(RX) LTE Band 4: 1710-1755MHz(TX); 2110-2155MHz(RX) LTE Band 5: 824-849MHz(TX); 869-894MHz(RX) LTE Band 7: 2500-2570MHz(TX); 2620-2690MHz(RX) LTE Band 38: 2570-2620MHz(TX); 2570-2620MHz(RX) LTE Band 41: 2535-2655MHz(TX); 2535-2655MHz(RX)
Maximum Target Output Power	EGSM 850: 33.0dBm(GMSK), 27.0dBm(8PSK) PCS 1900: 30.0dBm(GMSK), 28.0dBm(8PSK) WCDMA Band 2/4: 23.0dBm, WCDMA Band 5: 23.2dBm LTE Band 2/4/5/7/38/41: 22.5dBm
Modulation Technique	2G: GMSK, 8PSK 3G: BPSK, QPSK, 16QAM 4G: QPSK, 16QAM
Antenna Specification*	EGSM850/ WCDMA Band 5/ LTE Band 5: -1.9dBi PCS1900/ WCDMA Band 2/ LTE Band 2: -0.6dBi WCDMA Band 4/ LTE Band 4: -0.8dBi LTE Band 7/ Band 38/ Band 41: -0.3 dBi (provided by the applicant)
Voltage Range	DC 3.85V from battery or DC 5.0V from adapter
Date of Test	2020-11-09 to 2020-12-02
Sample serial number	RSZ201102004-RF-S1 (Assigned by BAACL, Shenzhen)
Received date	2020-11-02
Sample/EUT Status	Good condition
Adapter information	Model: U100XSA Input: AC 100-240V, 50/60Hz, 0.3A Output: DC 5.0V, 2.0A

Objective

This test report is in accordance with Part 2-Subpart J, Part 22-Subpart H and Part 24-Subpart E and Subpart 27 of the Federal Communication Commissions rules.

The objective is to determine the compliance of the EUT with FCC rules for output power, modulation characteristic, occupied bandwidth, and spurious emission at antenna terminal, spurious radiated emission, frequency stability and band edge.

Test Methodology

All tests and measurements indicated in this document were performed in accordance with the Code of Federal Regulations Title 47 Part 2-Subpart J as well as the following parts:

Part 22 Subpart H - Public Mobile Services
 Part 24 Subpart E - Personal Communication Services
 Part 27 – Miscellaneous wireless communications services

ANSI C63.26-2015: American National Standard for Compliance Testing of Transmitters Used in Licensed Radio Services

All emissions measurement was performed at Bay Area Compliance Laboratories Corp. (Shenzhen). The radiated testing was performed at an antenna-to-EUT distance of 3 meters.

Measurement Uncertainty

Parameter		Uncertainty
Occupied Channel Bandwidth		±5%
RF output power, conducted		±0.73dB
Unwanted Emission, conducted		±1.6dB
Emissions, Radiated	Below 1GHz	±4.75dB
	Above 1GHz	±4.88dB
Temperature		±1 °C
Humidity		±6%
Supply voltages		±0.4%

Note: The extended uncertainty given in this report is obtained by combining the standard uncertainty times the coverage factor K with the 95% confidence interval. Otherwise required by the applicant or Product Regulations, Decision Rule in this report did not consider the uncertainty.

Test Facility

The Test site used by Bay Area Compliance Laboratories Corp. (Shenzhen) to collect test data is located on the 6/F., West Wing, Third Phase of Wanli Industrial Building, Shihua Road, Futian Free Trade Zone, Shenzhen, Guangdong, China.

The test site has been approved by the FCC under the KDB 974614 D01 and is listed in the FCC Public Access Link (PAL) database, FCC Registration No.: 342867, the FCC Designation No.: CN1221.

The test site has been registered with ISED Canada under ISED Canada Registration Number 3062B.

SYSTEM TEST CONFIGURATION

Description of Test Configuration

The final qualification test was performed with the EUT operating at normal mode.

Equipment Modifications

No modification was made to the EUT.

Support Equipment List and Details

Manufacturer	Description	Model	Serial Number
Rohde & Schwarz	Wideband Radio Communication Tester	CMW500	1201.002K50-116218-UY
Rohde & Schwarz	Universal Radio Communication Tester	CMU200	110605

Support Cable Description

Cable Description	Length (m)	From / Port	To
Unshielded Un-detachable AC cable	1.2	AC Power	CMW500/ CMU200

Block Diagram of Test Setup

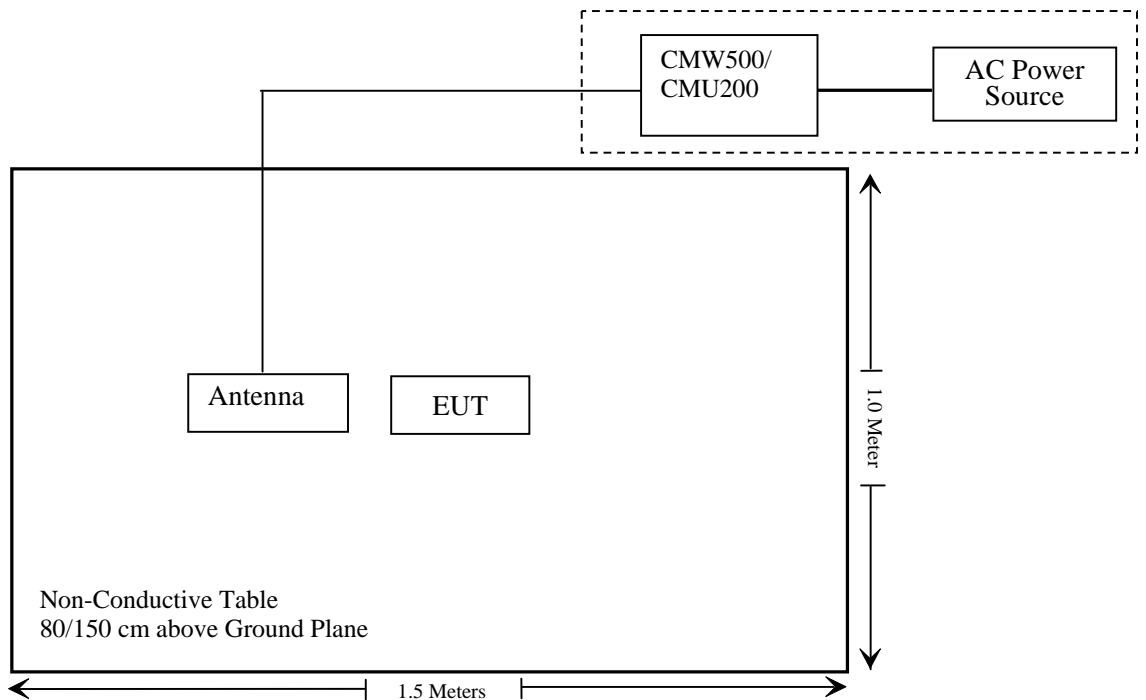

SUMMARY OF TEST RESULTS

FCC Rules	Description of Test	Result
§ 1.1307 , §2.1093	RF Exposure (SAR)	Compliance*
§2.1046; § 22.913 (a); § 24.232 (c); §27.50 (c) (d) (h)	RF Output Power	Compliance
§ 2.1047	Modulation Characteristics	Not Applicable
§ 2.1049; § 22.905; § 22.917; § 24.238; §27.53	Occupied Bandwidth	Compliance
§ 2.1051; § 22.917 (a); § 24.238 (a); §27.53	Spurious Emissions at Antenna Terminal	Compliance
§ 2.1053; § 22.917 (a); § 24.238 (a); §27.53	Field Strength of Spurious Radiation	Compliance
§ 22.917 (a); § 24.238 (a); §27.53(h) (m)	Band Edge	Compliance
§ 2.1055; § 22.355; § 24.235; §27.54;	Frequency stability	Compliance

Note: * Please refer to SAR report released by BACL, report number: RSZ201102004-SA.

TEST EQUIPMENT LIST

Manufacturer	Description	Model	Serial Number	Calibration Date	Calibration Due Date
Radiated Emission Test					
R&S	EMI Test Receiver	ESR3	102455	2020/08/04	2021/08/03
Sonoma instrument	Pre-amplifier	310 N	186238	2020/08/04	2021/08/03
Sunol Sciences	Broadband Antenna	JB1	A040904-1	2017/12/22	2020/12/21
COM-POWER	Dipole Antenna	AD-100	721027	NCR	NCR
Unknown	Cable 2	RF Cable 2	F-03-EM197	2019/11/29	2020/11/28
Unknown	Cable	Chamber Cable 1	F-03-EM236	2019/11/29	2020/11/28
Rohde & Schwarz	Spectrum Analyzer	FSV40-N	102259	2020/08/04	2021/08/03
COM-POWER	Pre-amplifier	PA-122	181919	2019/11/29	2020/11/28
Quinstar	Amplifier	QLW-18405536-J0	15964001002	2019/11/29	2020/11/28
Sunol Sciences	Horn Antenna	DRH-118	A052604	2017/12/22	2020/12/21
A.H.System	Horn Antenna	SAS-200/571	135	2018/09/01	2021/08/31
Insulated Wire Inc.	RF Cable	SPS-2503-3150	02222010	2019/11/29	2020/11/28
Unknown	RF Cable	W1101-EQ1 OUT	F-19-EM005	2019/11/29	2020/11/28
MICRO-TRONICS	Passband filter	HPM50111	F-19-EM006	2020/04/20	2021/04/20
Unknown	High Pass filter	1.3GHz	101120	2020/04/20	2021/04/20
Ducommun Technologies	Horn antenna	ARH-4223-02	1007726-02 1304	2017/12/06	2020/12/05
Ducommun Technologies	Horn antenna	ARH-4223-02	1007726-01 1304	2017/12/06	2020/12/05
Agilent	Signal Generator	N5183A	MY51040755	2019/12/04	2020/12/04

Manufacturer	Description	Model	Serial Number	Calibration Date	Calibration Due Date
RF Conducted Test					
Rohde & Schwarz	SPECTRUM ANALYZER	FSU26	200120	2020/04/03	2021/04/02
Yijia	Temperature & Humidity Meter	10316377	T-03-EM397	2020/10/14	2021/10/13
Rohde & Schwarz	Wideband Radio Communication Tester	CMW500	1201.002K50-146520-wh	2020/08/04	2021/08/03
Unknown	RF Cable	Unknown	2301 276	2019/11/29	2020/11/28
Unknown	RF Cable	Unknown	2301 276	2020/11/29	2021/11/28
Unknown	RF Cable	Unknown	DLO J5/W6102	2019/11/29	2020/11/28
Unknown	RF Cable	Unknown	DLO J5/W6102	2020/11/29	2021/11/28
Weinschel	Power divider	1515	MY628	2019/11/29	2020/11/28
Weinschel	Power divider	1515	MY628	2020/11/29	2021/11/28
Rohde & Schwarz	Universal Radio Communication Tester	CMU200	115500	2020/07/31	2021/07/30
instek	DC Power Supply	GPS-3030DD	EM832096	NCR	NCR
Fluke	Digital Multimeter	287	19000011	2020/07/23	2021/07/22

* Statement of Traceability: Bay Area Compliance Laboratories Corp. (Shenzhen) attests that all calibrations have been performed in accordance to requirements that traceable to National Primary Standards and International System of Units (SI).

FCC §1.1307(b) & §2.1093 - RF EXPOSURE INFORMATION

Applicable Standard

FCC§1.1310 and §2.1093.

Test Result

Compliance, please refer to the SAR report: RSZ201102004-SA.

FCC §2.1047 - MODULATION CHARACTERISTIC

According to FCC § 2.1047(d), Part 22H & 24E & 27 there is no specific requirement for digital modulation, therefore modulation characteristic is not presented.

FCC § 2.1046, § 22.913 (a) & § 24.232 (c); §27.50 (c) (d) (h) - RF OUTPUT POWER

Applicable Standard

According to FCC §2.1046 and §22.913 (a), the ERP of mobile transmitters and auxiliary test transmitters must not exceed 7 watts.

According to FCC §2.1046 and §24.232 (C), mobile and portable stations are limited to 2 watts EIRP and the equipment must employ a means for limiting power to the minimum necessary for successful communications.

The peak-to-average power ratio (PAPR) of the transmitter output power must not exceed 13 dB.

According to §27.50(d), the maximum EIRP must not exceed 1Watts (30dBm) for 1710-1755MHz.

According to §27.50(h), the maximum EIRP must not exceed 2Watts (33dBm) for 2500-2570MHz & 2496-2690MHz.

Test Procedure

Conducted method:

The RF output of the transmitter was connected to the CMW500/CMU200 through sufficient attenuation.

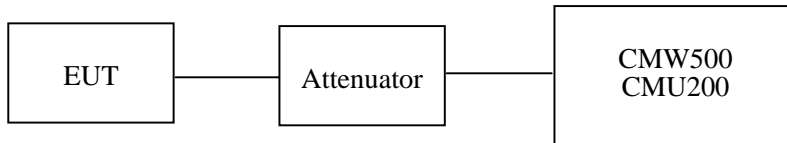

Radiated method:

TIA 603-D section 2.2.17

Test Data

Environmental Conditions

Temperature:	25 °C
Relative Humidity:	55 %
ATM Pressure:	101.0 kPa

The testing was performed by Coco Liu on 2020-11-09.

Conducted Power

Cellular Band (Part 22H)

Mode	Channel	Frequency (MHz)	Average Output Power (dBm)	ERP(dBm)	Limit (dBm)
GSM	128	824.2	32.80	27.75	38.45
	190	836.6	32.68	27.63	38.45
	251	848.8	31.60	26.55	38.45

Mode	Channel	Frequency (MHz)	Average Output Power (dBm)				ERP(dBm)				Limit (dBm)
			1 slot	2 slots	3 slots	4 slots	1 slot	2 slots	3 slots	4 slots	
GPRS	128	824.2	32.85	31.60	29.71	28.55	27.80	26.55	24.66	23.50	38.45
	190	836.6	32.65	31.46	29.54	28.38	27.60	26.41	24.49	23.33	38.45
	251	848.8	32.58	31.40	29.26	28.30	27.53	26.35	24.21	23.25	38.45

Mode	Channel	Frequency (MHz)	Average Output Power (dBm)				ERP(dBm)				Limit (dBm)
			1 slot	2 slots	3 slots	4 slots	1 slot	2 slots	3 slots	4 slots	
EGPRS	128	824.2	26.27	25.00	24.97	23.82	21.22	19.95	18.92	17.77	38.45
	190	836.6	26.17	24.86	24.84	23.67	21.12	19.81	18.79	17.62	38.45
	251	848.8	26.00	24.72	24.69	23.55	20.95	19.67	18.64	17.50	38.45

Mode	Test Mode	3GPP Sub Test	Average Output Power (dBm)			ERP(dBm)		
			Low	Mid	High	Low	Mid	High
WCDMA (Band 5)	RMC12.2k		23.08	23.15	23.18	18.03	18.10	18.13
	HSDPA	1	22.04	22.08	22.12	16.99	17.03	17.07
		2	22.12	22.21	22.17	17.07	17.16	17.12
		3	21.85	21.91	22.07	16.80	16.86	17.02
		4	21.88	22.09	22.11	16.83	17.04	17.06
	HSUPA	1	21.65	21.70	21.76	16.60	16.65	16.71
		2	21.58	21.56	21.97	16.53	16.51	16.92
		3	21.68	21.59	21.60	16.63	16.54	16.55
		4	21.60	21.81	21.73	16.55	16.76	16.68
		5	21.63	21.67	21.97	16.58	16.62	16.92

Note: ERP(dBm) = Conducted Power(dBm) + Antenna Gain(dBd) - Cable loss(dB)
 For GSM850 / WCDMA Band5: Antenna Gain = -1.9dBi = -4.05dBd (0dBd=2.15dBi)
 For 700-960MHz, Cable Loss=1dB* (provided by the applicant)
 Limit: ERP ≤ 38.45dBm

PCS Band (Part 24E)

Mode	Channel	Frequency (MHz)	Average Output Power (dBm)	EIRP(dBm)	Limit (dBm)
GSM	512	1850.2	29.14	27.74	33
	661	1880.0	29.18	27.78	33
	810	1909.8	29.38	27.98	33

Mode	Channel	Frequency (MHz)	Average Output Power (dBm)				EIRP(dBm)				Limit (dBm)
			1 slot	2 slots	3 slots	4 slots	1 slot	2 slots	3 slots	4 slots	
GPRS	512	1850.2	29.20	28.18	26.20	25.10	27.80	26.78	24.80	23.70	33
	661	1880.0	29.21	28.21	26.22	25.12	27.81	26.81	24.82	23.72	33
	810	1909.8	29.40	28.42	26.45	25.31	28.00	27.02	25.05	23.91	33

Mode	Channel	Frequency (MHz)	Average Output Power (dBm)				EIRP(dBm)				Limit (dBm)
			1 slot	2 slots	3 slots	4 slots	1 slot	2 slots	3 slots	4 slots	
EGPRS	512	1850.2	27.75	26.62	25.58	24.61	26.35	25.22	24.18	23.21	33
	661	1880.0	27.08	25.90	24.87	24.02	25.68	24.50	23.47	22.62	33
	810	1909.8	26.75	25.58	24.54	23.70	25.35	24.18	23.14	22.30	33

Mode	Test Mode	3GPP Sub Test	Average Output Power (dBm)			EIRP(dBm)		
			Low	Mid	High	Low	Mid	High
WCDMA (Band 2)	RMC12.2k		23.00	22.92	22.97	21.60	21.52	21.57
	HSDPA	1	22.64	22.23	22.39	21.24	20.83	20.99
		2	22.54	22.38	22.29	21.14	20.98	20.89
		3	22.52	22.22	22.27	21.12	20.82	20.87
		4	22.09	22.52	22.13	20.69	21.12	20.73
	HSUPA	1	21.96	21.85	21.71	20.56	20.45	20.31
		2	21.79	21.96	21.54	20.39	20.56	20.14
		3	21.88	21.71	21.63	20.48	20.31	20.23
		4	21.98	21.75	21.73	20.58	20.35	20.33
		5	21.86	21.67	21.61	20.46	20.27	20.21

Note: EIRP(dBm) = Conducted Power(dBm) + Antenna Gain(dBi) - Cable loss(dB)
 For PCS1900 / WCDMA Band2: Antenna Gain = -0.6dBi
 For 1700-2000MHz, Cable Loss=0.8dB*(provided by the applicant)
 Limit: EIRP ≤ 33dBm

AWS Band (Part 27)

Mode	Test Mode	3GPP Sub Test	Average Output Power (dBm)			EIRP(dBm)		
			Low	Mid	High	Low	Mid	High
WCDMA (Band 4)	RMC12.2k		22.85	22.80	22.85	21.25	21.20	21.25
	HSDPA	1	21.82	21.77	21.78	20.22	20.17	20.18
		2	21.61	21.61	21.60	20.01	20.01	20.00
		3	21.85	21.71	21.90	20.25	20.11	20.30
		4	21.82	21.77	21.92	20.22	20.17	20.32
	HSUPA	1	21.42	21.37	21.39	19.82	19.77	19.79
		2	21.55	21.28	21.43	19.95	19.68	19.83
		3	21.29	21.40	21.28	19.69	19.80	19.68
		4	21.45	21.35	21.33	19.85	19.75	19.73
		5	21.31	21.36	21.35	19.71	19.76	19.75

Note: EIRP(dBm) = Conducted Power(dBm) + Antenna Gain(dBi) - Cable loss(dB)
 For Band4: Antenna Gain = -0.8dBi
 For 1700-2000MHz, Cable Loss=0.8dB*(provided by the applicant)
 Limit: EIRP ≤ 30dBm

Peak-to-average ratio (PAR)

Cellular Band

Mode	Channel	PAR (dB)	Limit (dB)
GSM	Low	3.14	13
	Middle	3.30	13
	High	3.42	13

Mode	Channel	PAR (dB)	Limit (dB)
EGPRS	Low	3.18	13
	Middle	3.52	13
	High	3.22	13

Mode	Channel	PAR (dB)	Limit (dB)
RMC (BPSK)	Low	3.54	13
	Middle	3.31	13
	High	3.51	13
HSDPA (16QAM)	Low	3.24	13
	Middle	3.36	13
	High	3.52	13
HSUPA (BPSK)	Low	3.20	13
	Middle	3.39	13
	High	3.28	13

PCS Band

Mode	Channel	PAR (dB)	Limit (dB)
GSM	Low	3.34	13
	Middle	3.21	13
	High	3.73	13

Mode	Channel	PAR (dB)	Limit (dB)
EGPRS	Low	3.26	13
	Middle	3.14	13
	High	3.46	13

Mode	Channel	PAR (dB)	Limit (dB)
RMC (BPSK)	Low	3.55	13
	Middle	3.43	13
	High	3.63	13
HSDPA (16QAM)	Low	3.1	13
	Middle	3.11	13
	High	3.52	13
HSUPA (BPSK)	Low	3.42	13
	Middle	3.38	13
	High	3.13	13

AWS Band

Mode	Channel	PAR (dB)	Limit (dB)
RMC (BPSK)	Low	3.46	13
	Middle	3.13	13
	High	3.25	13
HSDPA (16QAM)	Low	3.15	13
	Middle	3.43	13
	High	3.73	13
HSUPA (BPSK)	Low	3.62	13
	Middle	3.72	13
	High	3.61	13

LTE Band 2:

Maximum Output Power

Bandwidth (MHz)	Modulation	RB size/ RB Offset	Conducted Average Output Power (dBm)			EIRP(dBm)		
			Low	Mid	High	Low	Mid	High
1.4	QPSK	RB1#0	21.54	21.33	21.41	20.14	19.93	20.01
		RB1#2	21.70	21.53	21.56	20.30	20.13	20.16
		RB1#5	21.61	21.42	21.42	20.21	20.02	20.02
		RB3#0	21.83	21.90	21.91	20.43	20.50	20.51
		RB3#1	21.79	21.81	21.87	20.39	20.41	20.47
		RB3#2	21.75	21.77	21.73	20.35	20.37	20.33
		RB6#0	20.59	20.43	20.47	19.19	19.03	19.07
	16QAM	RB1#0	20.68	20.35	20.40	19.28	18.95	19.00
		RB1#2	20.82	20.53	20.58	19.42	19.13	19.18
		RB1#5	20.38	20.41	20.47	18.98	19.01	19.07
		RB3#0	20.24	20.59	20.66	18.84	19.19	19.26
		RB3#1	20.25	20.37	20.48	18.85	18.97	19.08
		RB3#2	20.05	20.56	20.64	18.65	19.16	19.24
		RB6#0	19.96	19.52	19.84	18.56	18.12	18.44
3.0	QPSK	RB1#0	21.39	21.46	21.31	19.99	20.06	19.91
		RB1#7	21.65	21.49	21.69	20.25	20.09	20.29
		RB1#14	21.55	21.35	21.37	20.15	19.95	19.97
		RB8#0	21.74	22.05	22.17	20.34	20.65	20.77
		RB8#4	21.95	21.84	21.79	20.55	20.44	20.39
		RB8#7	21.82	22.01	21.76	20.42	20.61	20.36
		RB15#0	20.58	20.37	20.49	19.18	18.97	19.09
	16QAM	RB1#0	20.56	20.30	20.26	19.16	18.90	18.86
		RB1#7	20.77	20.65	20.69	19.37	19.25	19.29
		RB1#14	20.16	20.44	20.44	18.76	19.04	19.04
		RB8#0	20.18	20.65	20.62	18.78	19.25	19.22
		RB8#4	20.31	20.34	20.67	18.91	18.94	19.27
		RB8#7	19.97	20.59	20.76	18.57	19.19	19.36
		RB15#0	19.92	19.46	19.91	18.52	18.06	18.51

Bandwidth (MHz)	Modulation	RB size/ RB Offset	Conducted Average Output Power (dBm)			EIRP(dBm)		
			Low	Mid	High	Low	Mid	High
5.0	QPSK	RB1#0	21.36	21.38	21.51	19.96	19.98	20.11
		RB1#12	21.85	21.51	21.54	20.45	20.11	20.14
		RB1#24	21.58	21.32	21.47	20.18	19.92	20.07
		RB12#0	21.73	21.88	21.87	20.33	20.48	20.47
		RB12#6	21.92	21.75	21.68	20.52	20.35	20.28
		RB12#11	21.59	21.62	21.64	20.19	20.22	20.24
		RB25#0	20.69	20.22	20.61	19.29	18.82	19.21
	16QAM	RB1#0	20.54	20.36	20.49	19.14	18.96	19.09
		RB1#12	20.65	20.43	20.74	19.25	19.03	19.34
		RB1#24	20.29	20.59	20.40	18.89	19.19	19.00
		RB12#0	20.24	20.58	20.56	18.84	19.18	19.16
		RB12#6	20.07	20.48	20.64	18.67	19.08	19.24
		RB12#11	20.04	20.57	20.72	18.64	19.17	19.32
		RB25#0	19.80	19.48	19.86	18.40	18.08	18.46
10.0	QPSK	RB1#0	21.24	21.44	21.46	19.84	20.04	20.06
		RB1#24	21.62	21.29	21.40	20.22	19.89	20.00
		RB1#49	21.65	21.46	21.49	20.25	20.06	20.09
		RB25#0	22.04	21.99	22.18	20.64	20.59	20.78
		RB25#12	21.82	21.55	21.77	20.42	20.15	20.37
		RB25#24	21.78	21.72	21.96	20.38	20.32	20.56
		RB50#0	20.58	20.60	20.63	19.18	19.20	19.23
	16QAM	RB1#0	20.65	20.62	20.53	19.25	19.22	19.13
		RB1#24	20.68	20.52	20.51	19.28	19.12	19.11
		RB1#49	20.28	20.50	20.60	18.88	19.10	19.20
		RB25#0	20.37	20.60	20.65	18.97	19.20	19.25
		RB25#12	20.49	20.17	20.54	19.09	18.77	19.14
		RB25#24	20.21	20.73	20.50	18.81	19.33	19.10
		RB50#0	19.80	19.34	19.90	18.40	17.94	18.50

Bandwidth (MHz)	Modulation	RB size/ RB Offset	Conducted Average Output Power (dBm)			EIRP(dBm)		
			Low	Mid	High	Low	Mid	High
15.0	QPSK	RB1#0	21.21	21.22	21.18	19.81	19.82	19.78
		RB1#37	21.76	21.46	21.43	20.36	20.06	20.03
		RB1#74	21.62	21.41	21.33	20.22	20.01	19.93
		RB36#0	21.90	21.94	22.02	20.50	20.54	20.62
		RB36#18	21.78	21.79	21.68	20.38	20.39	20.28
		RB36#37	21.75	21.68	21.82	20.35	20.28	20.42
		RB75#0	20.61	20.45	20.39	19.21	19.05	18.99
	16QAM	RB1#0	20.87	20.27	20.34	19.47	18.87	18.94
		RB1#37	20.71	20.58	20.50	19.31	19.18	19.10
		RB1#74	20.41	20.26	20.55	19.01	18.86	19.15
		RB36#0	20.12	20.75	20.91	18.72	19.35	19.51
		RB36#18	20.21	20.52	20.34	18.81	19.12	18.94
		RB36#37	20.02	20.34	20.49	18.62	18.94	19.09
		RB75#0	19.96	19.60	19.60	18.56	18.20	18.20
20.0	QPSK	RB1#0	21.17	21.15	21.40	19.77	19.75	20.00
		RB1#49	21.72	21.51	21.52	20.32	20.11	20.12
		RB1#99	21.63	21.52	21.49	20.23	20.12	20.09
		RB50#0	21.67	21.80	21.90	20.27	20.40	20.50
		RB50#24	21.88	21.66	21.97	20.48	20.26	20.57
		RB50#49	21.71	21.68	21.68	20.31	20.28	20.28
		RB100#0	20.70	20.41	20.32	19.30	19.01	18.92
	16QAM	RB1#0	20.65	20.19	20.54	19.25	18.79	19.14
		RB1#49	20.81	20.63	20.55	19.41	19.23	19.15
		RB1#99	20.42	20.28	20.72	19.02	18.88	19.32
		RB50#0	20.36	20.40	20.47	18.96	19.00	19.07
		RB50#24	20.36	20.29	20.57	18.96	18.89	19.17
		RB50#49	20.03	20.58	20.58	18.63	19.18	19.18
		RB100#0	19.96	19.59	20.09	18.56	18.19	18.69

Note: EIRP(dBm) = Conducted Power(dBm) + Antenna Gain(dBi) - Cable loss(dB)
 For Band2: Antenna Gain = -0.6dBi
 For 1700-2000MHz, Cable Loss=0.8dB*(provided by the applicant)
 Limit: EIRP ≤ 33dBm

Peak-to-average ratio (PAR)**20MHz Bandwidth**

Modulation	Low channel (dB)	Middle channel (dB)	High channel (dB)	PAR Limit (dB)	Result
QPSK (1RB Size)	3.21	4.20	3.14	13	Pass
QPSK (100RB Size)	5.11	5.25	5.24	13	Pass
16QAM (1RB Size)	4.13	4.41	4.28	13	Pass
16QAM (100RB Size)	6.24	6.31	6.04	13	Pass

LTE Band 4

Bandwidth (MHz)	Modulation	RB size/ RB Offset	Conducted Average Output Power (dBm)			EIRP(dBm)		
			Low	Mid	High	Low	Mid	High
1.4	QPSK	RB1#0	22.00	21.99	21.81	20.40	20.39	20.21
		RB1#2	21.93	21.48	21.32	20.33	19.88	19.72
		RB1#5	21.42	21.26	21.61	19.82	19.66	20.01
		RB3#0	21.90	21.92	21.75	20.30	20.32	20.15
		RB3#1	21.52	21.77	21.98	19.92	20.17	20.38
		RB3#2	21.90	21.55	21.75	20.30	19.95	20.15
		RB6#0	20.82	20.51	20.38	19.22	18.91	18.78
	16QAM	RB1#0	20.65	20.28	20.47	19.05	18.68	18.87
		RB1#2	20.84	20.45	20.44	19.24	18.85	18.84
		RB1#5	20.16	20.42	20.41	18.56	18.82	18.81
		RB3#0	20.25	20.54	20.85	18.65	18.94	19.25
		RB3#1	20.32	20.45	20.57	18.72	18.85	18.97
		RB3#2	20.05	20.55	20.75	18.45	18.95	19.15
		RB6#0	19.94	19.79	19.82	18.34	18.19	18.22
3.0	QPSK	RB1#0	22.12	21.69	21.89	20.52	20.09	20.29
		RB1#7	21.62	21.41	21.64	20.02	19.81	20.04
		RB1#14	21.41	21.46	21.15	19.81	19.86	19.55
		RB8#0	21.97	21.90	21.95	20.37	20.30	20.35
		RB8#4	21.88	21.84	21.86	20.28	20.24	20.26
		RB8#7	21.84	21.74	21.59	20.24	20.14	19.99
		RB15#0	20.67	20.61	20.39	19.07	19.01	18.79
	16QAM	RB1#0	20.80	20.51	20.33	19.20	18.91	18.73
		RB1#7	20.73	20.41	20.38	19.13	18.81	18.78
		RB1#14	20.34	20.42	20.52	18.74	18.82	18.92
		RB8#0	20.15	20.51	20.78	18.55	18.91	19.18
		RB8#4	20.15	20.43	20.47	18.55	18.83	18.87
		RB8#7	20.18	20.50	20.89	18.58	18.90	19.29
		RB15#0	19.90	19.63	19.83	18.30	18.03	18.23

Bandwidth (MHz)	Modulation	RB size/ RB Offset	Conducted Average Output Power (dBm)			EIRP(dBm)		
			Low	Mid	High	Low	Mid	High
5.0	QPSK	RB1#0	21.95	21.69	22.16	20.35	20.09	20.56
		RB1#12	21.85	21.57	21.58	20.25	19.97	19.98
		RB1#24	21.56	21.35	21.49	19.96	19.75	19.89
		RB12#0	21.77	22.00	22.06	20.17	20.40	20.46
		RB12#6	21.92	22.09	21.73	20.32	20.49	20.13
		RB12#11	21.81	21.76	21.65	20.21	20.16	20.05
		RB25#0	20.65	20.52	20.47	19.05	18.92	18.87
	16QAM	RB1#0	20.82	20.45	20.41	19.22	18.85	18.81
		RB1#12	20.60	20.36	20.64	19.00	18.76	19.04
		RB1#24	20.32	20.45	20.23	18.72	18.85	18.63
		RB12#0	20.22	20.59	20.75	18.62	18.99	19.15
		RB12#6	20.25	20.38	20.44	18.65	18.78	18.84
		RB12#11	20.16	20.59	20.62	18.56	18.99	19.02
		RB25#0	19.81	19.40	19.98	18.21	17.80	18.38
10.0	QPSK	RB1#0	21.61	21.74	21.82	20.01	20.14	20.22
		RB1#24	21.83	21.67	21.58	20.23	20.07	19.98
		RB1#49	21.68	21.31	21.47	20.08	19.71	19.87
		RB25#0	21.76	21.82	21.68	20.16	20.22	20.08
		RB25#12	21.83	21.98	21.74	20.23	20.38	20.14
		RB25#24	21.88	21.61	21.66	20.28	20.01	20.06
		RB50#0	20.66	20.62	20.35	19.06	19.02	18.75
	16QAM	RB1#0	20.64	20.29	20.63	19.04	18.69	19.03
		RB1#24	20.78	20.41	20.53	19.18	18.81	18.93
		RB1#49	20.20	20.40	20.45	18.60	18.80	18.85
		RB25#0	20.28	20.70	20.71	18.68	19.10	19.11
		RB25#12	20.32	20.34	20.58	18.72	18.74	18.98
		RB25#24	20.10	20.77	20.62	18.50	19.17	19.02
		RB50#0	19.98	19.56	19.80	18.38	17.96	18.20

Bandwidth (MHz)	Modulation	RB size/ RB Offset	Conducted Average Output Power (dBm)			EIRP(dBm)		
			Low	Mid	High	Low	Mid	High
15.0	QPSK	RB1#0	21.86	22.04	21.81	20.26	20.44	20.21
		RB1#37	21.71	21.47	21.36	20.11	19.87	19.76
		RB1#74	21.70	21.40	21.31	20.10	19.80	19.71
		RB36#0	21.98	21.92	21.98	20.38	20.32	20.38
		RB36#18	21.70	21.79	21.95	20.10	20.19	20.35
		RB36#37	21.72	21.65	21.74	20.12	20.05	20.14
		RB75#0	20.69	20.66	20.57	19.09	19.06	18.97
	16QAM	RB1#0	20.59	20.24	20.48	18.99	18.64	18.88
		RB1#37	20.86	20.40	20.59	19.26	18.80	18.99
		RB1#74	20.41	20.35	20.30	18.81	18.75	18.70
		RB36#0	20.44	20.67	20.75	18.84	19.07	19.15
		RB36#18	20.48	20.18	20.33	18.88	18.58	18.73
		RB36#37	20.26	20.36	20.57	18.66	18.76	18.97
		RB75#0	19.95	19.63	19.63	18.35	18.03	18.03
20.0	QPSK	RB1#0	21.96	21.60	21.85	20.36	20.00	20.25
		RB1#49	21.88	21.64	21.50	20.28	20.04	19.90
		RB1#99	21.71	21.29	21.51	20.11	19.69	19.91
		RB50#0	21.94	22.00	21.90	20.34	20.40	20.30
		RB50#24	21.75	21.92	22.01	20.15	20.32	20.41
		RB50#49	21.94	21.72	21.73	20.34	20.12	20.13
		RB100#0	20.59	20.55	20.67	18.99	18.95	19.07
	16QAM	RB1#0	20.71	20.30	20.22	19.11	18.70	18.62
		RB1#49	20.83	20.53	20.68	19.23	18.93	19.08
		RB1#99	20.46	20.32	20.33	18.86	18.72	18.73
		RB50#0	20.15	20.52	20.63	18.55	18.92	19.03
		RB50#24	20.29	20.11	20.30	18.69	18.51	18.70
		RB50#49	20.21	20.64	20.63	18.61	19.04	19.03
		RB100#0	19.98	19.47	19.83	18.38	17.87	18.23

Note: EIRP(dBm) = Conducted Power(dBm) + Antenna Gain(dBi) - Cable loss(dB)
 For Band4: Antenna Gain = -0.8dBi
 For 1700-2000MHz, Cable Loss=0.8dB*(provided by the applicant)
 Limit: EIRP ≤ 30dBm

Peak-to-average ratio (PAR)**20MHz Bandwidth**

Modulation	Low channel (dB)	Middle channel (dB)	High channel (dB)	PAR Limit (dB)	Result
QPSK (1RB Size)	4.42	4.25	4.35	13	Pass
QPSK (100RB Size)	5.63	5.54	5.86	13	Pass
16QAM (1RB Size)	5.25	5.24	4.86	13	Pass
16QAM (100RB Size)	6.24	6.16	6.24	13	Pass

LTE Band 5:

Maximum Output Power

Bandwidth (MHz)	Modulation	RB size/ RB Offset	Conducted Average Output Power (dBm)			ERP(dBm)		
			Low	Mid	High	Low	Mid	High
1.4	QPSK	RB1#0	21.92	21.86	21.70	16.87	16.81	16.65
		RB1#2	21.74	21.48	21.50	16.69	16.43	16.45
		RB1#5	21.53	21.28	21.36	16.48	16.23	16.31
		RB3#0	21.61	21.84	21.69	16.56	16.79	16.64
		RB3#1	21.81	21.79	21.88	16.76	16.74	16.83
		RB3#2	21.88	21.95	21.61	16.83	16.90	16.56
		RB6#0	20.63	20.51	20.37	15.58	15.46	15.32
	16QAM	RB1#0	20.81	20.53	20.17	15.76	15.48	15.12
		RB1#2	20.84	20.38	20.68	15.79	15.33	15.63
		RB1#5	20.49	20.21	20.55	15.44	15.16	15.50
		RB3#0	20.48	20.39	20.64	15.43	15.34	15.59
		RB3#1	20.46	20.10	20.46	15.41	15.05	15.41
		RB3#2	20.16	20.40	20.82	15.11	15.35	15.77
		RB6#0	19.98	19.66	19.94	14.93	14.61	14.89
3.0	QPSK	RB1#0	21.70	21.71	21.69	16.65	16.66	16.64
		RB1#7	21.62	21.42	21.51	16.57	16.37	16.46
		RB1#14	21.61	21.24	21.52	16.56	16.19	16.47
		RB8#0	21.71	22.06	21.97	16.66	17.01	16.92
		RB8#4	21.67	21.80	21.88	16.62	16.75	16.83
		RB8#7	21.50	22.00	21.72	16.45	16.95	16.67
		RB15#0	20.62	20.32	20.47	15.57	15.27	15.42
	16QAM	RB1#0	20.80	20.43	20.36	15.75	15.38	15.31
		RB1#7	21.08	20.65	20.44	16.03	15.60	15.39
		RB1#14	20.29	20.24	20.55	15.24	15.19	15.50
		RB8#0	20.25	20.42	20.68	15.20	15.37	15.63
		RB8#4	20.20	20.35	20.45	15.15	15.30	15.40
		RB8#7	19.85	20.63	20.64	14.80	15.58	15.59
		RB15#0	21.70	21.71	21.69	16.65	16.66	16.64

Bandwidth (MHz)	Modulation	RB size/ RB Offset	Conducted Average Output Power (dBm)			ERP(dBm)		
			Low	Mid	High	Low	Mid	High
5.0	QPSK	RB1#0	21.62	21.75	21.73	16.57	16.70	16.68
		RB1#12	21.77	21.39	21.58	16.72	16.34	16.53
		RB1#24	21.71	21.49	21.65	16.66	16.44	16.60
		RB12#0	21.83	21.92	21.93	16.78	16.87	16.88
		RB12#6	21.82	21.73	22.04	16.77	16.68	16.99
		RB12#11	22.01	21.99	21.77	16.96	16.94	16.72
		RB25#0	20.54	20.31	20.34	15.49	15.26	15.29
	16QAM	RB1#0	20.68	20.36	20.40	15.63	15.31	15.35
		RB1#12	20.76	20.55	20.64	15.71	15.50	15.59
		RB1#24	20.34	20.18	20.60	15.29	15.13	15.55
		RB12#0	20.50	20.55	20.57	15.45	15.50	15.52
		RB12#6	20.34	20.25	20.52	15.29	15.20	15.47
		RB12#11	20.03	20.49	20.62	14.98	15.44	15.57
		RB25#0	19.81	19.76	19.77	14.76	14.71	14.72
10.0	QPSK	RB1#0	21.80	21.82	21.71	16.75	16.77	16.66
		RB1#24	21.67	21.78	21.69	16.62	16.73	16.64
		RB1#49	21.74	21.64	21.51	16.69	16.59	16.46
		RB25#0	21.61	22.20	21.90	16.56	17.15	16.85
		RB25#12	21.58	21.81	21.70	16.53	16.76	16.65
		RB25#24	21.91	21.76	21.61	16.86	16.71	16.56
		RB50#0	20.56	20.41	20.48	15.51	15.36	15.43
	16QAM	RB1#0	20.71	20.22	20.54	15.66	15.17	15.49
		RB1#24	20.67	20.61	20.66	15.62	15.56	15.61
		RB1#49	20.41	20.26	20.36	15.36	15.21	15.31
		RB25#0	20.26	20.42	20.74	15.21	15.37	15.69
		RB25#12	20.37	20.45	20.57	15.32	15.40	15.52
		RB25#24	20.26	20.52	20.64	15.21	15.47	15.59
		RB50#0	20.11	19.67	19.75	15.06	14.62	14.70

Note: ERP(dBm) = Conducted Power(dBm) + Antenna Gain(dBd) - Cable loss(dB)
 For Band5: Antenna Gain = -1.9dBi = -4.05dBd (0dBd=2.15dBi)
 For 700-960MHz, Cable Loss= 1dB*(provided by the applicant)
 Limit: ERP ≤ 38.45dBm

Peak-to-average ratio (PAR)**10MHz bandwidth**

Modulation	Low channel (dB)	Middle channel (dB)	High channel (dB)	PAR Limit (dB)	Result
QPSK (1RB Size)	4.25	4.36	4.24	13	Pass
QPSK (50RB Size)	5.34	5.52	5.57	13	Pass
16QAM (1RB Size)	5.43	4.53	5.24	13	Pass
16QAM (50RB Size)	6.24	6.64	6.35	13	Pass

LTE Band 7:

Maximum Output Power

Bandwidth (MHz)	Modulation	RB size/ RB Offset	Conducted Average Output Power (dBm)			EIRP(dBm)		
			Low	Mid	High	Low	Mid	High
5.0	QPSK	RB1#0	22.18	21.91	21.88	21.38	21.11	21.08
		RB1#12	21.68	21.77	21.59	20.88	20.97	20.79
		RB1#24	21.50	21.38	21.51	20.70	20.58	20.71
		RB12#0	21.89	21.99	21.89	21.09	21.19	21.09
		RB12#6	21.82	21.97	21.74	21.02	21.17	20.94
		RB12#11	21.86	21.81	21.76	21.06	21.01	20.96
		RB25#0	20.77	20.42	20.48	19.97	19.62	19.68
	16QAM	RB1#0	20.88	20.49	20.36	20.08	19.69	19.56
		RB1#12	21.00	20.65	20.46	20.20	19.85	19.66
		RB1#24	20.23	20.37	20.37	19.43	19.57	19.57
		RB12#0	20.09	20.56	20.74	19.29	19.76	19.94
		RB12#6	20.19	20.49	20.37	19.39	19.69	19.57
		RB12#11	20.05	20.67	20.81	19.25	19.87	20.01
		RB25#0	19.81	19.70	19.84	19.01	18.90	19.04
10.0	QPSK	RB1#0	21.95	21.87	21.72	21.15	21.07	20.92
		RB1#24	21.60	21.50	21.59	20.80	20.70	20.79
		RB1#49	21.47	21.39	21.55	20.67	20.59	20.75
		RB25#0	22.01	22.02	21.69	21.21	21.22	20.89
		RB25#12	21.64	21.99	22.10	20.84	21.19	21.30
		RB25#24	21.61	21.81	21.87	20.81	21.01	21.07
		RB50#0	20.49	20.42	20.53	19.69	19.62	19.73
	16QAM	RB1#0	20.64	20.18	20.30	19.84	19.38	19.50
		RB1#24	20.73	20.36	20.53	19.93	19.56	19.73
		RB1#49	20.35	20.54	20.51	19.55	19.74	19.71
		RB25#0	20.14	20.45	20.49	19.34	19.65	19.69
		RB25#12	20.20	20.39	20.39	19.40	19.59	19.59
		RB25#24	20.30	20.61	20.64	19.50	19.81	19.84
		RB50#0	19.99	19.91	19.82	19.19	19.11	19.02

Bandwidth (MHz)	Modulation	RB size/ RB Offset	Conducted Average Output Power (dBm)			EIRP(dBm)		
			Low	Mid	High	Low	Mid	High
15.0	QPSK	RB1#0	21.95	22.17	22.04	21.15	21.37	21.24
		RB1#37	21.83	21.62	21.30	21.03	20.82	20.50
		RB1#74	21.86	21.46	21.17	21.06	20.66	20.37
		RB36#0	22.04	21.61	22.04	21.24	20.81	21.24
		RB36#18	22.24	22.02	21.79	21.44	21.22	20.99
		RB36#37	21.39	21.42	21.51	20.59	20.62	20.71
		RB75#0	20.37	20.47	20.48	19.57	19.67	19.68
	16QAM	RB1#0	20.84	20.35	20.34	20.04	19.55	19.54
		RB1#37	20.75	20.49	20.72	19.95	19.69	19.92
		RB1#74	20.66	20.26	20.26	19.86	19.46	19.46
		RB36#0	19.96	20.63	20.26	19.16	19.83	19.46
		RB36#18	20.42	20.59	20.28	19.62	19.79	19.48
		RB36#37	20.16	20.62	20.70	19.36	19.82	19.90
		RB75#0	20.03	19.57	19.87	19.23	18.77	19.07
20.0	QPSK	RB1#0	22.17	22.15	22.04	21.37	21.35	21.24
		RB1#49	21.60	21.49	21.57	20.80	20.69	20.77
		RB1#99	21.45	21.58	21.50	20.65	20.78	20.70
		RB50#0	21.69	21.91	21.82	20.89	21.11	21.02
		RB50#24	21.74	21.79	21.98	20.94	20.99	21.18
		RB50#49	21.90	21.96	21.77	21.10	21.16	20.97
		RB100#0	20.46	20.68	20.45	19.66	19.88	19.65
	16QAM	RB1#0	20.68	20.21	20.60	19.88	19.41	19.80
		RB1#49	21.05	20.41	20.63	20.25	19.61	19.83
		RB1#99	20.45	20.17	20.67	19.65	19.37	19.87
		RB50#0	20.26	20.51	20.69	19.46	19.71	19.89
		RB50#24	20.50	20.44	20.69	19.70	19.64	19.89
		RB50#49	20.03	20.81	20.68	19.23	20.01	19.88
		RB100#0	20.11	19.73	19.81	19.31	18.93	19.01

Note: EIRP(dBm) = Conducted Power(dBm) + Antenna Gain(dBi) - Cable loss(dB)
 For Band 7: Antenna Gain = -0.3dBi
 For 2000-3000MHz, Cable Loss=0.5dB*(provided by the applicant)
 Limit: EIRP ≤ 33dBm

Peak-to-average ratio (PAR)**20MHz bandwidth**

Modulation	Low channel (dB)	Middle channel (dB)	High channel (dB)	PAR Limit (dB)	Result
QPSK (1RB Size)	4.8	4.43	3.56	13	Pass
QPSK (100RB Size)	5.46	5.57	5.54	13	Pass
16QAM (1RB Size)	5.46	5.54	4.58	13	Pass
16QAM (100RB Size)	6.16	6.35	6.24	13	Pass

LTE Band 38

Maximum Output Power

Bandwidth (MHz)	Modulation	RB size/ RB Offset	Conducted Average Output Power (dBm)			EIRP(dBm)		
			Low	Mid	High	Low	Mid	High
5	QPSK	RB1#0	22.07	22.01	22.06	21.27	21.21	21.26
		RB1#2	21.78	21.88	21.82	20.98	21.08	21.02
		RB1#5	21.78	21.70	21.84	20.98	20.90	21.04
		RB3#0	21.59	21.75	21.74	20.79	20.95	20.94
		RB3#1	21.57	21.54	21.93	20.77	20.74	21.13
		RB3#2	21.54	21.74	21.85	20.74	20.94	21.05
		RB6#0	21.72	21.81	21.74	20.92	21.01	20.94
	16QAM	RB1#0	21.71	21.80	21.69	20.91	21.00	20.89
		RB1#2	21.84	21.86	21.61	21.04	21.06	20.81
		RB1#5	21.69	21.74	21.59	20.89	20.94	20.79
		RB3#0	21.80	21.49	21.88	21.00	20.69	21.08
		RB3#1	21.90	21.53	21.91	21.10	20.73	21.11
		RB3#2	21.61	21.95	21.97	20.81	21.15	21.17
		RB6#0	21.04	20.83	20.96	20.24	20.03	20.16
10	QPSK	RB1#0	22.11	22.05	22.04	21.31	21.25	21.24
		RB1#7	21.60	21.49	21.57	20.80	20.69	20.77
		RB1#14	21.45	21.58	21.50	20.65	20.78	20.70
		RB8#0	21.69	21.91	21.82	20.89	21.11	21.02
		RB8#4	21.74	21.79	21.98	20.94	20.99	21.18
		RB8#7	21.90	21.96	21.77	21.10	21.16	20.97
		RB15#0	20.46	20.68	20.45	19.66	19.88	19.65
	16QAM	RB1#0	20.68	20.21	20.60	19.88	19.41	19.80
		RB1#7	21.05	20.41	20.63	20.25	19.61	19.83
		RB1#14	20.45	20.17	20.67	19.65	19.37	19.87
		RB8#0	20.26	20.51	20.69	19.46	19.71	19.89
		RB8#4	20.50	20.44	20.69	19.70	19.64	19.89
		RB8#7	20.03	20.81	20.68	19.23	20.01	19.88
		RB15#0	20.11	19.73	19.81	19.31	18.93	19.01

Bandwidth (MHz)	Modulation	RB size/ RB Offset	Conducted Average Output Power (dBm)			EIRP(dBm)		
			Low	Mid	High	Low	Mid	High
15	QPSK	RB1#0	22.06	22.00	22.14	21.26	21.20	21.34
		RB1#12	21.42	21.89	21.67	20.62	21.09	20.87
		RB1#24	21.70	21.89	21.68	20.90	21.09	20.88
		RB12#0	21.82	21.58	21.77	21.02	20.78	20.97
		RB12#6	21.63	21.84	21.55	20.83	21.04	20.75
		RB12#11	21.61	21.95	21.85	20.81	21.15	21.05
		RB25#0	21.73	21.57	21.82	20.93	20.77	21.02
	16QAM	RB1#0	21.51	21.82	21.63	20.71	21.02	20.83
		RB1#12	21.73	21.98	22.05	20.93	21.18	21.25
		RB1#24	21.56	21.90	21.57	20.76	21.10	20.77
		RB12#0	21.91	21.80	22.03	21.11	21.00	21.23
		RB12#6	22.05	21.97	21.85	21.25	21.17	21.05
		RB12#11	21.91	21.54	22.15	21.11	20.74	21.35
		RB25#0	20.82	20.75	20.85	20.02	19.95	20.05
20.0	QPSK	RB1#0	21.90	22.02	21.84	21.10	21.22	21.04
		RB1#24	21.67	21.57	21.81	20.87	20.77	21.01
		RB1#49	21.56	21.60	21.96	20.76	20.80	21.16
		RB25#0	21.40	21.59	21.67	20.60	20.79	20.87
		RB25#12	21.77	21.67	21.64	20.97	20.87	20.84
		RB25#24	21.53	21.79	21.54	20.73	20.99	20.74
		RB50#0	21.71	21.79	21.95	20.91	20.99	21.15
	16QAM	RB1#0	21.69	21.79	21.63	20.89	20.99	20.83
		RB1#24	21.90	21.77	22.09	21.10	20.97	21.29
		RB1#49	21.77	21.75	21.86	20.97	20.95	21.06
		RB25#0	21.61	21.77	21.77	20.81	20.97	20.97
		RB25#12	21.72	21.63	21.59	20.92	20.83	20.79
		RB25#24	20.99	21.46	21.76	20.19	20.66	20.96
		RB50#0	20.79	20.90	20.59	19.99	20.10	19.79

Note: EIRP(dBm) = Conducted Power(dBm) + Antenna Gain(dBi) - Cable loss(dB)
 For Band 38: Antenna Gain = -0.3dBi
 For 2000-3000MHz, Cable Loss=0.5dB*(provided by the applicant)
 Limit: EIRP ≤ 33dBm

Peak-to-average ratio (PAR)**20MHz bandwidth**

Modulation	Low channel (dB)	Middle channel (dB)	High channel (dB)	PAR Limit (dB)	Result
QPSK (1RB Size)	4.24	4.25	4.28	13	Pass
QPSK (100RB Size)	5.28	5.25	5.17	13	Pass
16QAM (1RB Size)	5.43	5.32	5.46	13	Pass
16QAM (100RB Size)	6.04	6.17	6.68	13	Pass

LTE Band 41:

Maximum Output Power

Bandwidth (MHz)	Modulation	RB size/ RB Offset	Conducted Average Output Power (dBm)			EIRP(dBm)		
			Low	Mid	High	Low	Mid	High
5.0	QPSK	RB1#0	22.08	21.98	21.88	21.28	21.18	21.08
		RB1#12	21.69	21.84	21.80	20.89	21.04	21.00
		RB1#24	21.65	21.56	21.69	20.85	20.76	20.89
		RB12#0	21.63	21.64	21.69	20.83	20.84	20.89
		RB12#6	21.57	21.72	21.75	20.77	20.92	20.95
		RB12#11	21.80	21.54	21.87	21.00	20.74	21.07
		RB25#0	21.44	21.62	21.58	20.64	20.82	20.78
	16QAM	RB1#0	21.55	21.53	21.73	20.75	20.73	20.93
		RB1#12	21.54	21.92	21.83	20.74	21.12	21.03
		RB1#24	21.96	21.90	21.64	21.16	21.10	20.84
		RB12#0	21.69	21.99	21.67	20.89	21.19	20.87
		RB12#6	21.72	21.62	21.76	20.92	20.82	20.96
		RB12#11	20.70	21.23	21.71	19.90	20.43	20.91
		RB25#0	20.64	21.07	21.01	19.84	20.27	20.21
10.0	QPSK	RB1#0	22.05	22.11	22.03	21.25	21.31	21.23
		RB1#24	21.75	21.57	21.79	20.95	20.77	20.99
		RB1#49	21.60	21.66	21.88	20.80	20.86	21.08
		RB25#0	21.52	21.78	21.65	20.72	20.98	20.85
		RB25#12	21.74	21.67	21.79	20.94	20.87	20.99
		RB25#24	21.64	21.75	21.68	20.84	20.95	20.88
		RB50#0	21.74	21.57	21.70	20.94	20.77	20.90
	16QAM	RB1#0	21.79	21.61	21.90	20.99	20.81	21.10
		RB1#24	21.82	21.78	21.57	21.02	20.98	20.77
		RB1#49	21.95	21.96	21.74	21.15	21.16	20.94
		RB25#0	21.69	21.85	21.92	20.89	21.05	21.12
		RB25#12	21.73	21.63	21.95	20.93	20.83	21.15
		RB25#24	20.57	21.52	21.64	19.77	20.72	20.84
		RB50#0	20.73	20.75	20.75	19.93	19.95	19.95

Bandwidth (MHz)	Modulation	RB size/ RB Offset	Conducted Average Output Power (dBm)			EIRP(dBm)		
			Low	Mid	High	Low	Mid	High
15	QPSK	RB1#0	21.97	22.25	22.00	21.17	21.45	21.20
		RB1#12	21.64	21.67	21.74	20.84	20.87	20.94
		RB1#24	21.69	21.70	21.82	20.89	20.90	21.02
		RB12#0	21.66	21.58	21.62	20.86	20.78	20.82
		RB12#6	21.87	21.84	22.01	21.07	21.04	21.21
		RB12#11	21.85	21.87	21.89	21.05	21.07	21.09
		RB25#0	21.82	21.75	21.65	21.02	20.95	20.85
	16QAM	RB1#0	21.67	21.68	21.73	20.87	20.88	20.93
		RB1#12	21.96	21.72	21.60	21.16	20.92	20.80
		RB1#24	21.63	21.71	21.60	20.83	20.91	20.80
		RB12#0	21.85	22.10	22.01	21.05	21.30	21.21
		RB12#6	21.54	21.96	21.65	20.74	21.16	20.85
		RB12#11	20.59	21.54	21.62	19.79	20.74	20.82
		RB25#0	20.83	20.76	20.81	20.03	19.96	20.01
20.0	QPSK	RB1#0	21.85	22.20	21.88	21.05	21.40	21.08
		RB1#24	21.66	21.79	21.60	20.86	20.99	20.80
		RB1#49	21.50	21.77	21.73	20.70	20.97	20.93
		RB25#0	21.78	21.73	21.76	20.98	20.93	20.96
		RB25#12	21.61	21.49	21.77	20.81	20.69	20.97
		RB25#24	21.60	21.66	21.81	20.80	20.86	21.01
		RB50#0	21.63	21.53	21.81	20.83	20.73	21.01
	16QAM	RB1#0	21.72	21.65	21.57	20.92	20.85	20.77
		RB1#24	21.83	21.82	21.88	21.03	21.02	21.08
		RB1#49	21.86	21.90	21.82	21.06	21.10	21.02
		RB25#0	21.85	21.64	21.63	21.05	20.84	20.83
		RB25#12	21.94	21.84	21.72	21.14	21.04	20.92
		RB25#24	20.99	21.35	21.54	20.19	20.55	20.74
		RB50#0	21.85	22.20	21.88	21.05	21.40	21.08

Note: EIRP(dBm) = Conducted Power(dBm) + Antenna Gain(dBi) - Cable loss(dB)
 For Band 41: Antenna Gain = -0.3dBi
 For 2000-3000MHz, Cable Loss=0.5dB*(provided by the applicant)
 Limit: EIRP ≤ 33dBm

Peak-to-average ratio (PAR)**20MHz bandwidth**

Modulation	Low channel (dB)	Middle channel (dB)	High channel (dB)	PAR Limit (dB)	Result
QPSK (1RB Size)	4.57	4.45	4.42	13	Pass
QPSK (100RB Size)	5.45	5.24	5.24	13	Pass
16QAM (1RB Size)	5.42	5.54	5.53	13	Pass
16QAM (100RB Size)	6.64	6.35	6.21	13	Pass

FCC §2.1049, §22.917, §22.905 & §24.238 & §27.53 - OCCUPIED BANDWIDTH

Applicable Standard

FCC 47 §2.1049, §22.917, §22.905, §24.238 and §27.53.

Test Procedure

The RF output of the transmitter was connected to the simulator and the spectrum analyzer through sufficient attenuation.

The resolution bandwidth of the spectrum analyzer was set at 1% to 5% of the anticipated emission bandwidth and the 26 dB & 99% bandwidth was recorded.

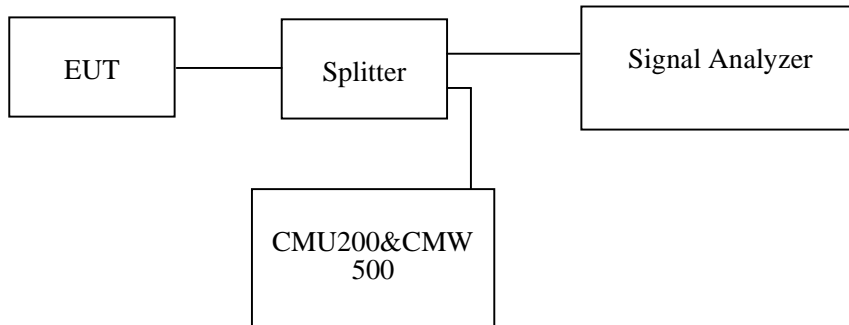

Test Data

Environmental Conditions

Temperature:	25 °C
Relative Humidity:	55 %
ATM Pressure:	101.0 kPa

The testing was performed by Coco Liu from 2020-11-09 to 2020-11-26.

EUT operation mode: Transmitting

Test Result: Pass

Please refer to the following tables and plots.

Cellular Band (Part 22H)

Mode	Channel	Frequency (MHz)	99% Occupied Bandwidth (kHz)	26 dB Emission Bandwidth (kHz)
GSM(GMSK)	128	824.2	243.59	315.71
	190	836.6	243.59	322.12
	251	848.8	245.19	317.31
EGPRS(8PSK)	128	824.2	250.00	312.50
	190	836.6	248.40	317.31
	251	848.8	248.40	315.38

	Frequency (MHz)	Occupied Bandwidth (MHz)	26dB Bandwidth (MHz)
RMC	826.4	4.20	5.21
	836.6	4.20	4.73
	846.6	4.18	4.76
HSDPA	826.4	4.20	4.78
	836.6	4.20	4.70
	846.6	4.21	4.85
HSUPA	826.4	4.20	4.97
	836.6	4.20	4.90
	846.6	4.20	4.77

PCS Band (Part 24E)

Mode	Channel	Frequency (MHz)	99% Occupied Bandwidth (kHz)	26 dB Emission Bandwidth (kHz)
GSM(GMSK)	512	1850.2	245.19	314.10
	661	1880.0	243.59	305.13
	810	1909.8	246.79	316.35
EGPRS(8PSK)	512	1850.2	253.21	320.51
	661	1880.0	251.60	322.12
	810	1909.8	250.00	318.91

Frequency (MHz)		Occupied Bandwidth (MHz)	26dB Bandwidth (MHz)
RMC	1852.4	4.20	4.73
	1880.0	4.18	4.73
	1907.6	4.18	4.73
HSDPA	1852.4	4.21	4.73
	1880.0	4.20	4.74
	1907.6	4.18	4.71
HSUPA	1852.4	4.17	4.73
	1880.0	4.20	4.73
	1907.6	4.20	4.73

AWS Band (Part 27)

Frequency (MHz)		Occupied Bandwidth (MHz)	26dB Bandwidth (MHz)
RMC	1712.4	4.18	4.74
	1732.6	4.18	4.71
	1752.6	4.20	4.73
HSDPA	1712.4	4.20	4.71
	1732.6	4.18	4.73
	1752.6	4.18	4.71
HSUPA	1712.4	4.18	4.73
	1732.6	4.23	6.51
	1752.6	4.18	4.71

Cellular Band (Part 22H)

26 dB Emissions & 99% Occupied Bandwidth for GSM (GMSK) Mode, Low channel

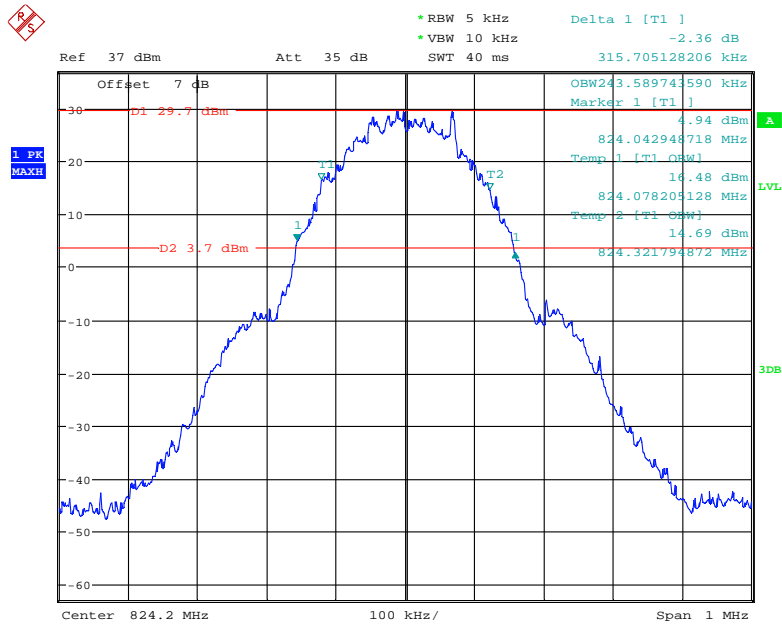

Date: 9.NOV.2020 10:58:45

26 dB Emissions & 99% Occupied Bandwidth for GSM (GMSK) Mode, Middle channel

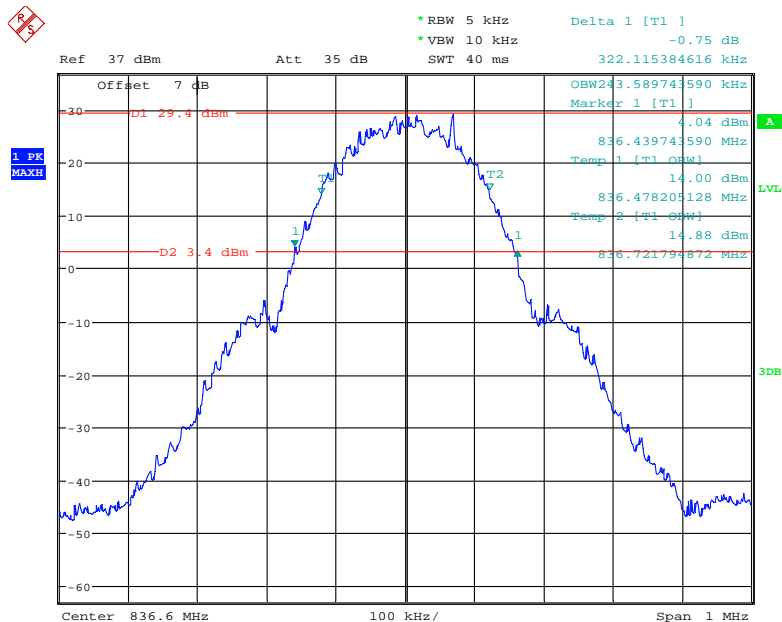

Date: 9.NOV.2020 10:57:31

26 dB Emissions & 99% Occupied Bandwidth for GSM (GMSK) Mode, High channel

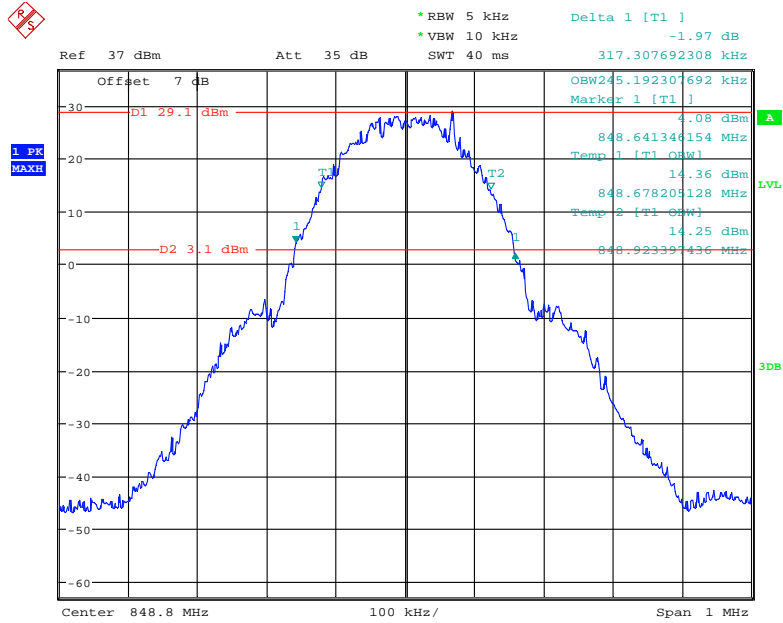

Date: 9.NOV.2020 10:55:46

26 dB Emissions & 99% Occupied Bandwidth for EGPRS (8PSK) Mode, Low channel

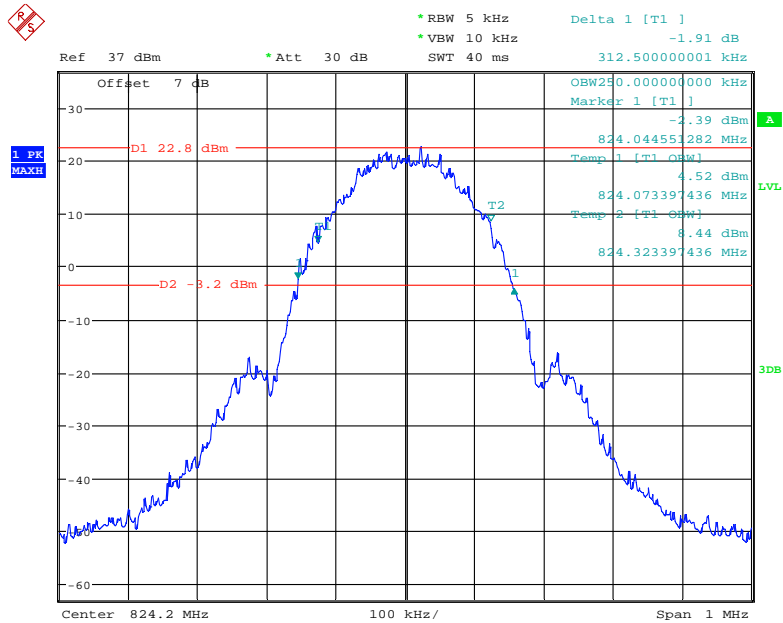

Date: 9.NOV.2020 11:08:34

26 dB Emissions & 99% Occupied Bandwidth for EGPRS (8PSK) Mode, Middle channel

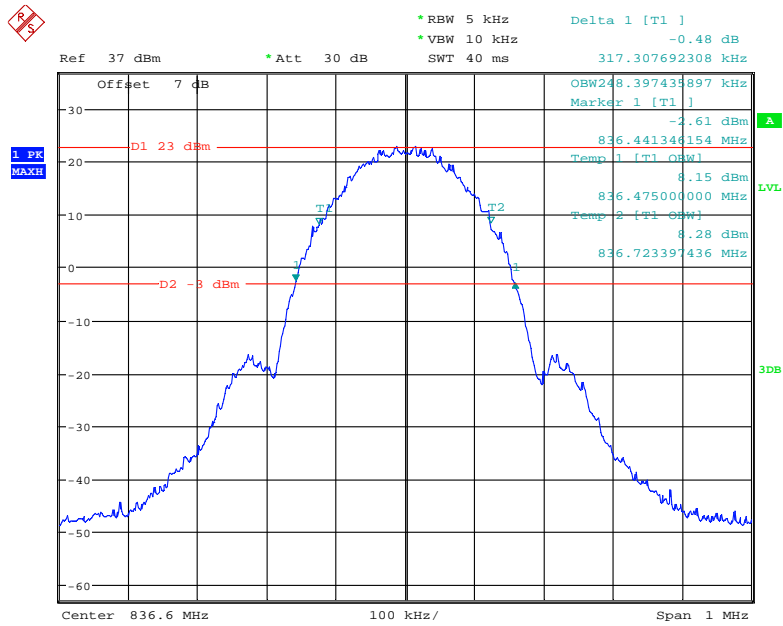

Date: 9.NOV.2020 11:40:09

26 dB Emissions & 99% Occupied Bandwidth for EGPRS (8PSK) Mode, High channel

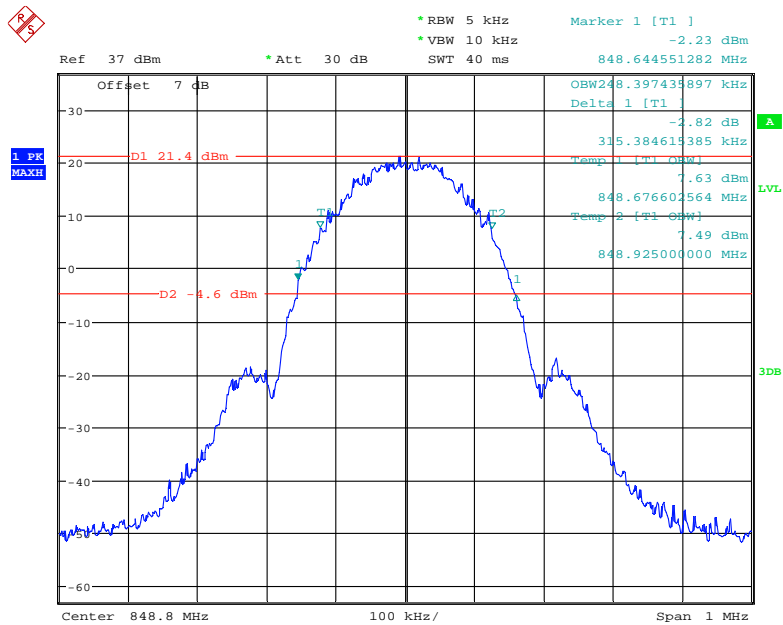

Date: 9.NOV.2020 11:42:34

26 dB Emissions Bandwidth for RMC (BPSK) Mode, Low channel

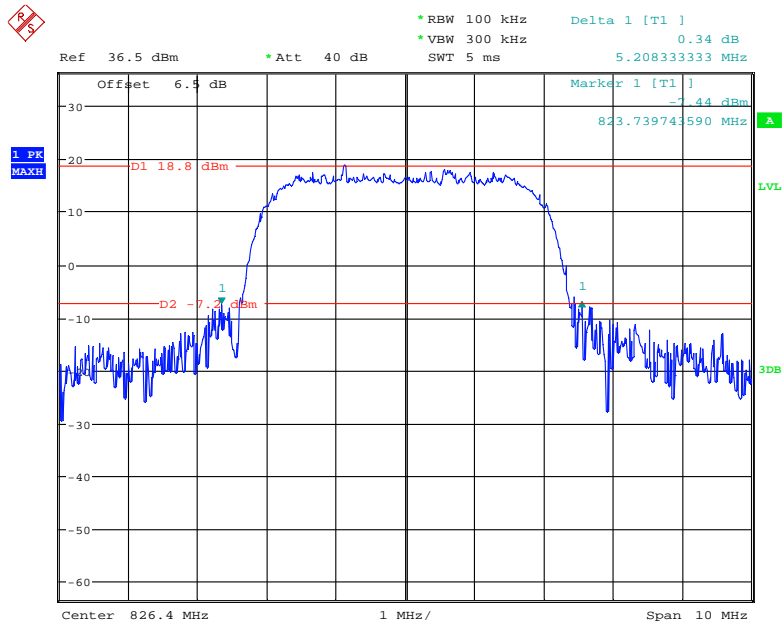

Date: 17.NOV.2020 15:15:38

26 dB Emissions Bandwidth for RMC (BPSK) Mode, Middle channel

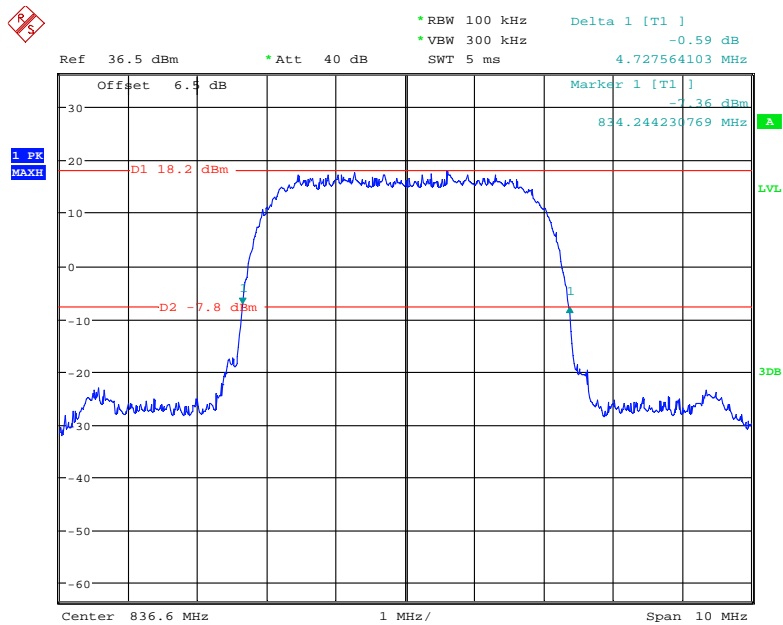

Date: 17.NOV.2020 15:14:33

26 dB Emissions Bandwidth for RMC (BPSK) Mode, High channel

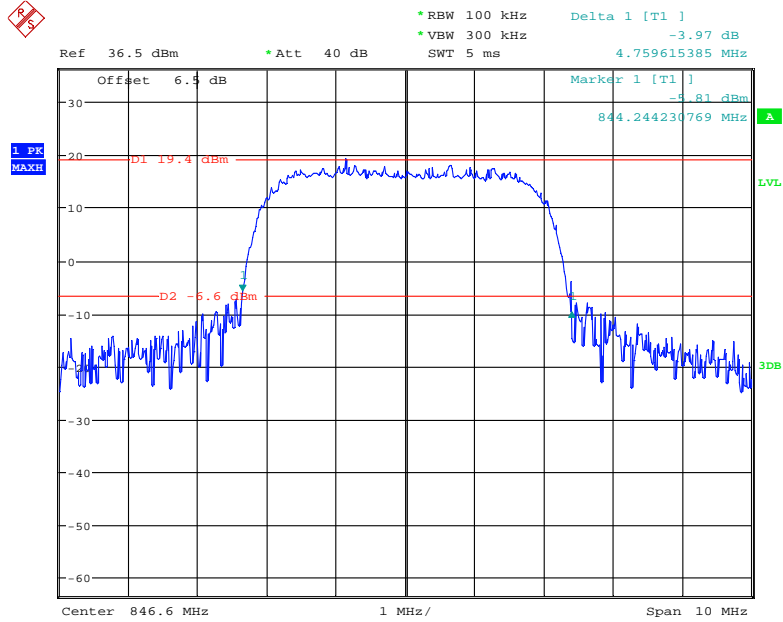

Date: 17.NOV.2020 15:13:28

26 dB Emissions Bandwidth for HSUPA (BPSK) Mode, Low channel

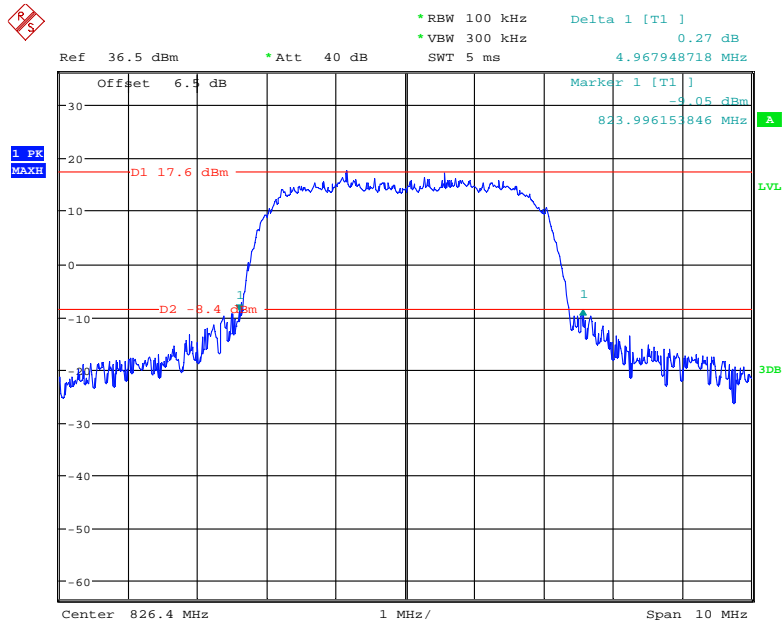

Date: 17.NOV.2020 15:16:43

26 dB Emissions Bandwidth for HSUPA (BPSK) Mode, Middle channel

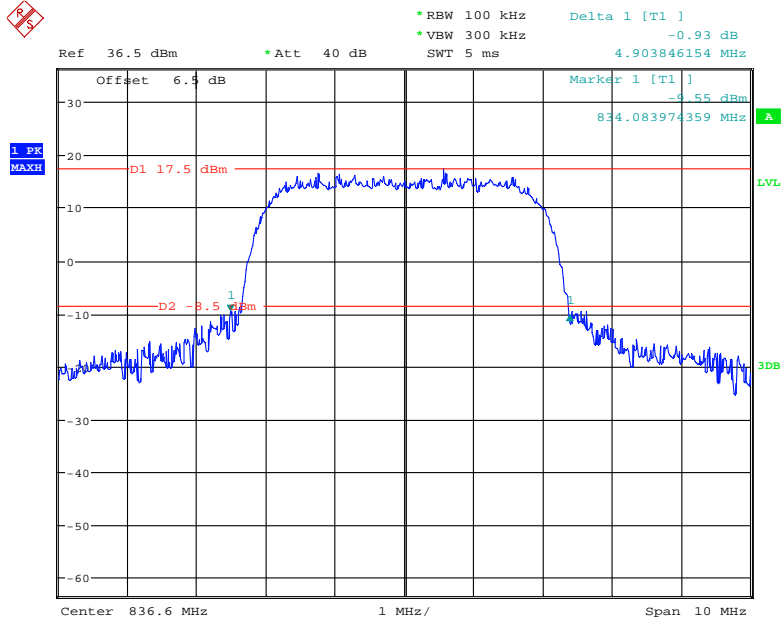

Date: 17.NOV.2020 15:18:26

26 dB Emissions Bandwidth for HSUPA (BPSK) Mode, High channel

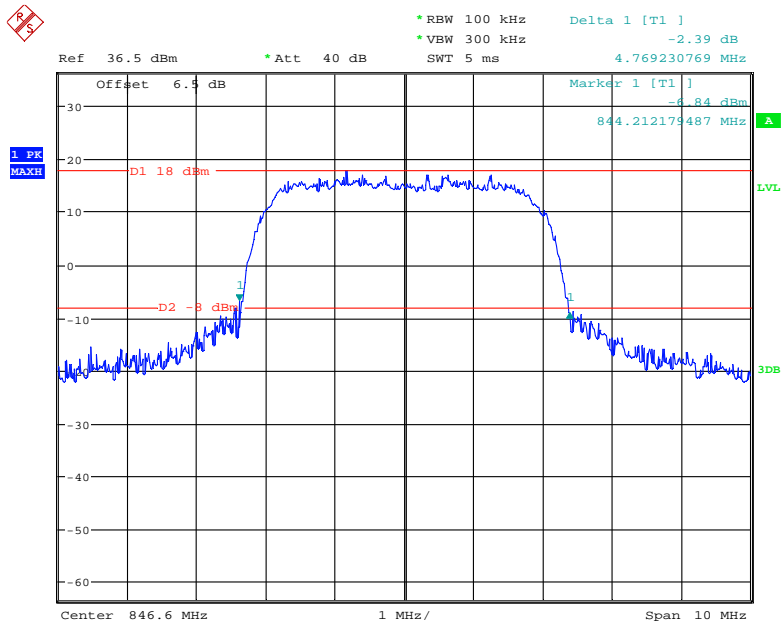

Date: 17.NOV.2020 15:19:42

26 dB Emissions Bandwidth for HSDPA (16QAM) Mode, Low channel

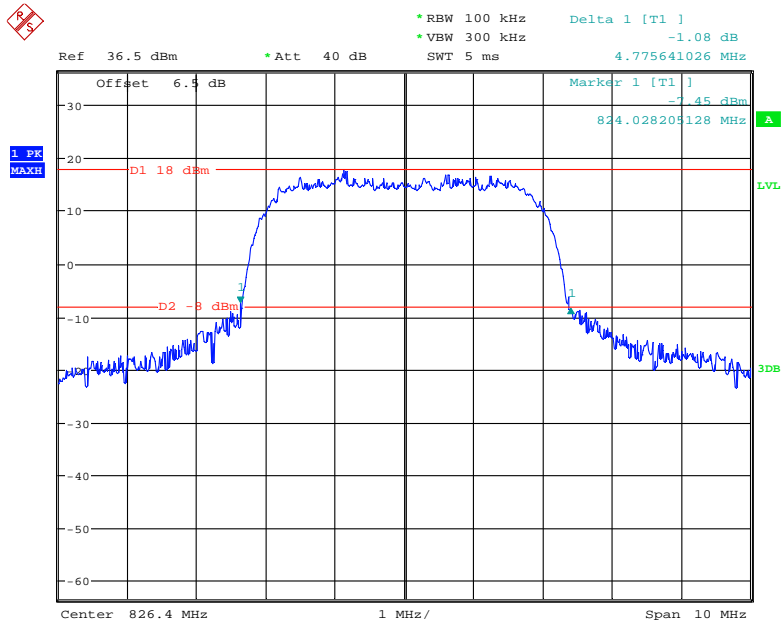

Date: 17.NOV.2020 15:23:43

26 dB Emissions Bandwidth for HSDPA (16QAM) Mode, Middle channel

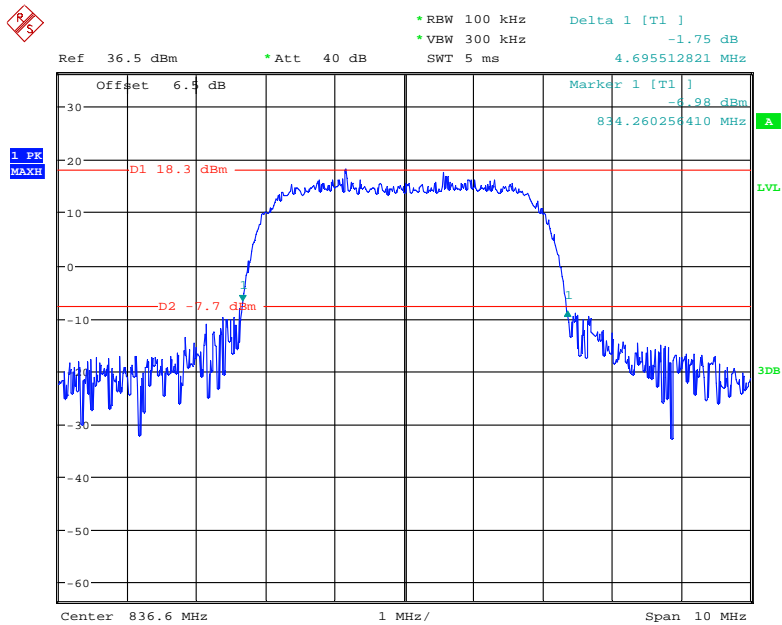

Date: 17.NOV.2020 15:22:18

26 dB Emissions Bandwidth for HSDPA (16QAM) Mode, High channel

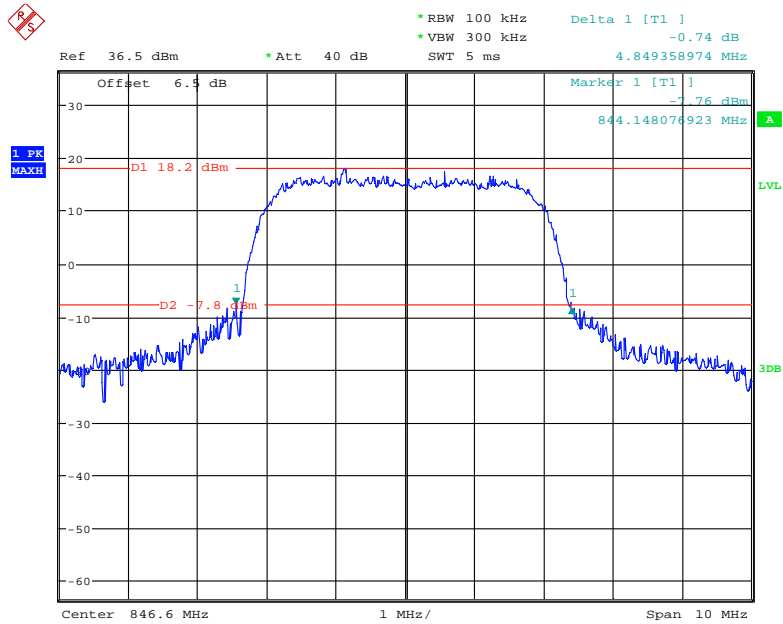

Date: 17.NOV.2020 15:21:12

99% Occupied Bandwidth for RMC (BPSK) Mode, Low channel

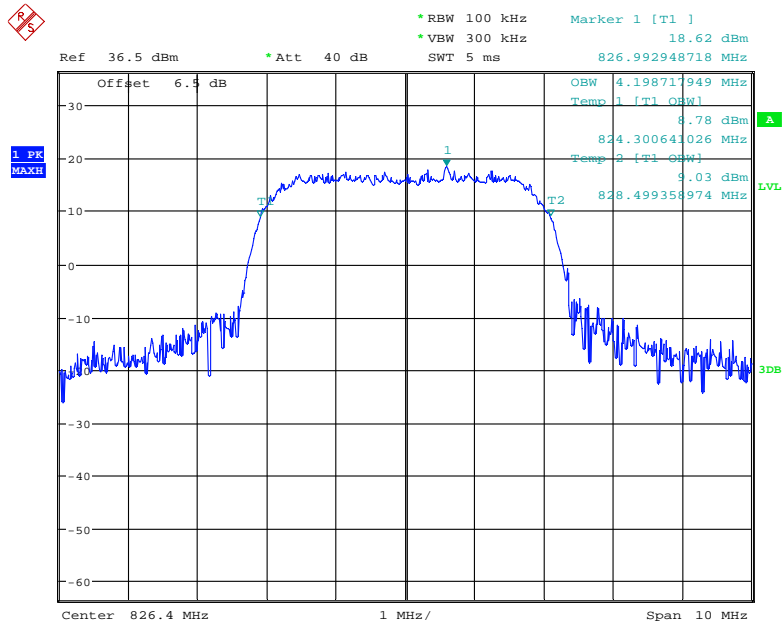

Date: 17.NOV.2020 15:48:13

99% Occupied Bandwidth for RMC (BPSK) Mode, Middle channel

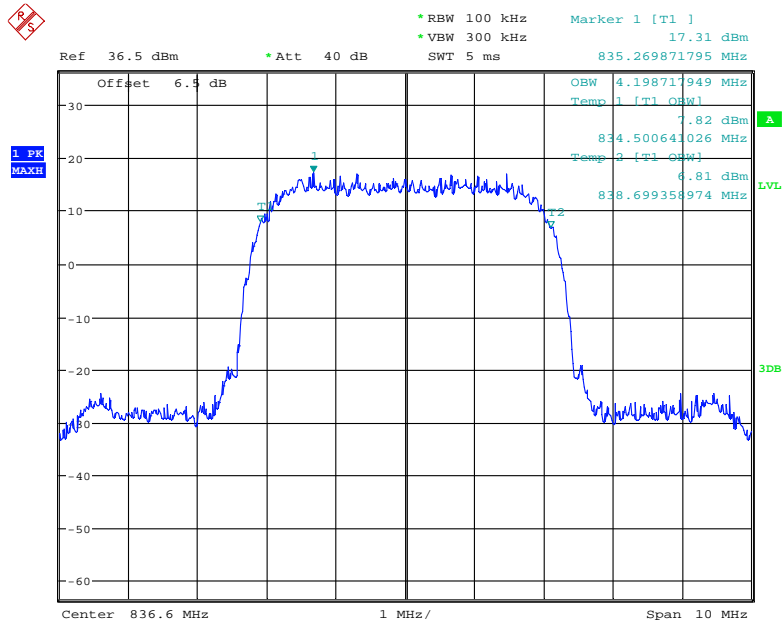

Date: 17.NOV.2020 15:47:06

99% Occupied Bandwidth for RMC (BPSK) Mode, High channel

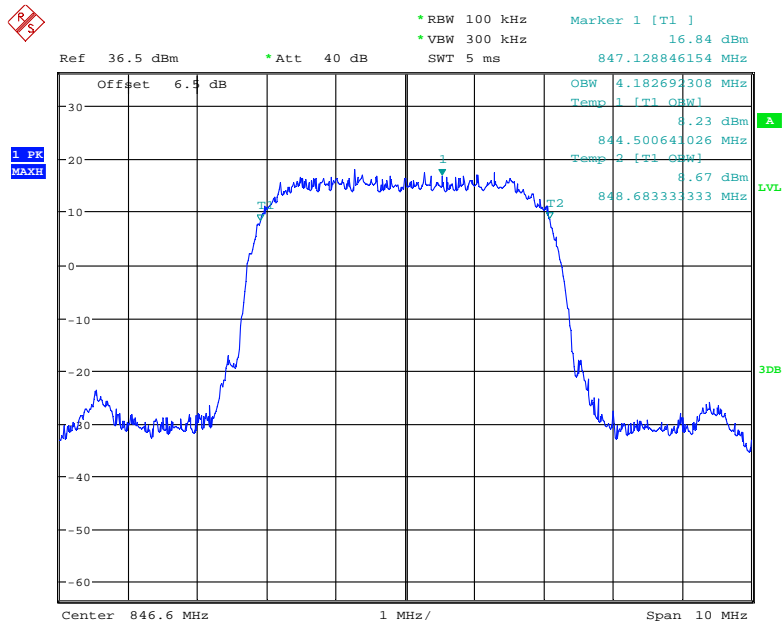

Date: 17.NOV.2020 15:46:38

99% Occupied Bandwidth for HSUPA (BPSK) Mode, Low channel

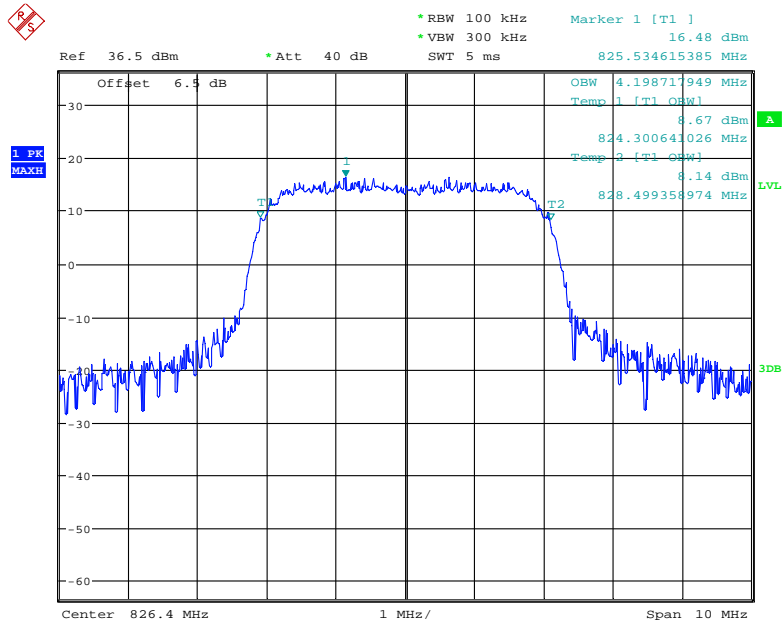

Date: 17.NOV.2020 15:43:01

99% Occupied Bandwidth for HSUPA (BPSK) Mode, Middle channel

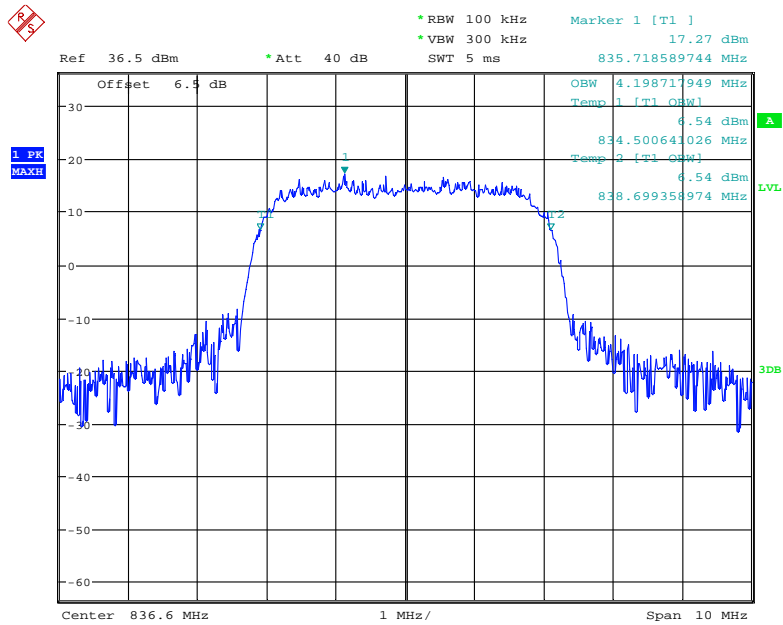

Date: 17.NOV.2020 15:42:15

99% Occupied Bandwidth for HSDP (BPSK) Mode, Low channel

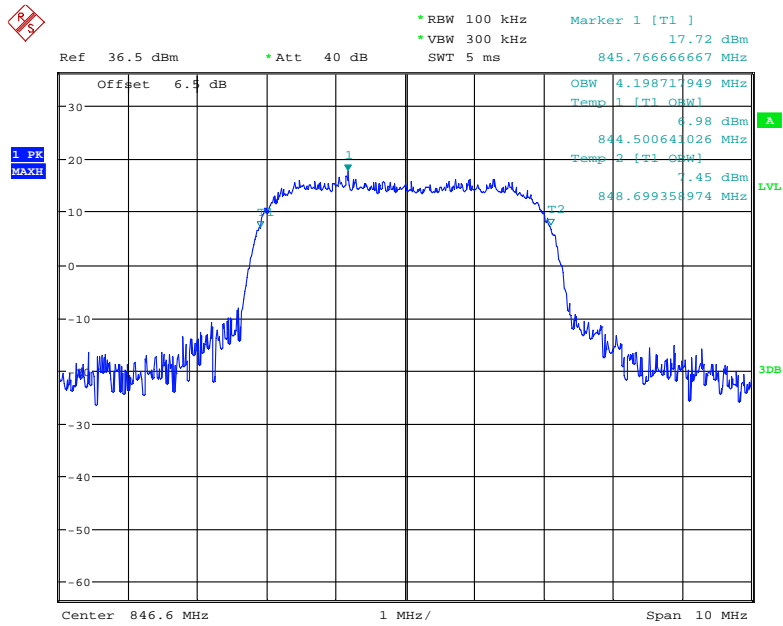

Date: 17.NOV.2020 15:41:15

99% Occupied Bandwidth for HSDPA (16QAM) Mode, Low channel

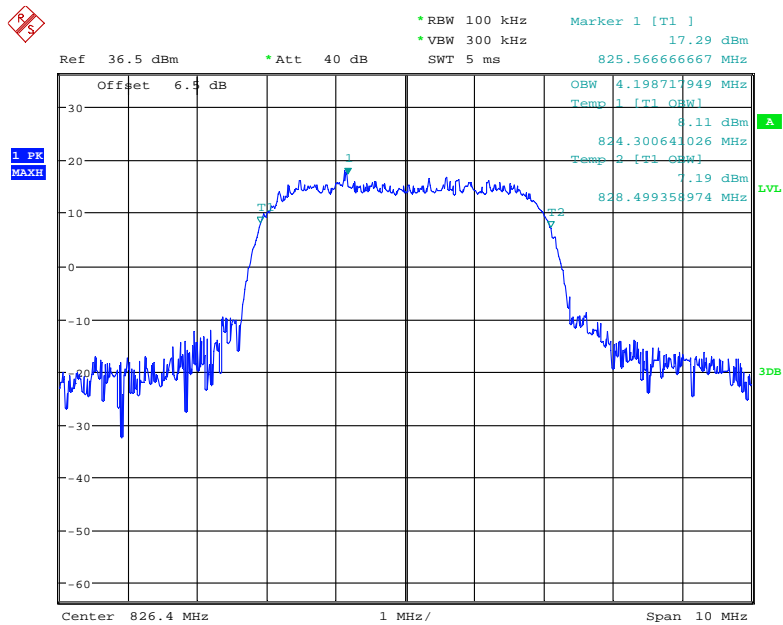

Date: 17.NOV.2020 15:30:12

99% Occupied Bandwidth for HSDPA (16QAM) Mode, Middle channel

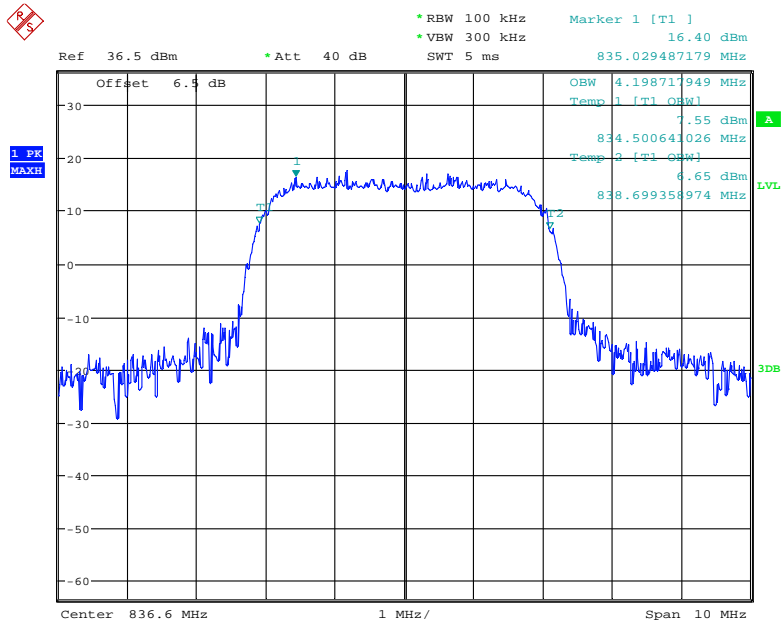

Date: 17.NOV.2020 15:31:23

99% Occupied Bandwidth for HSDPA (16QAM) Mode, High channel

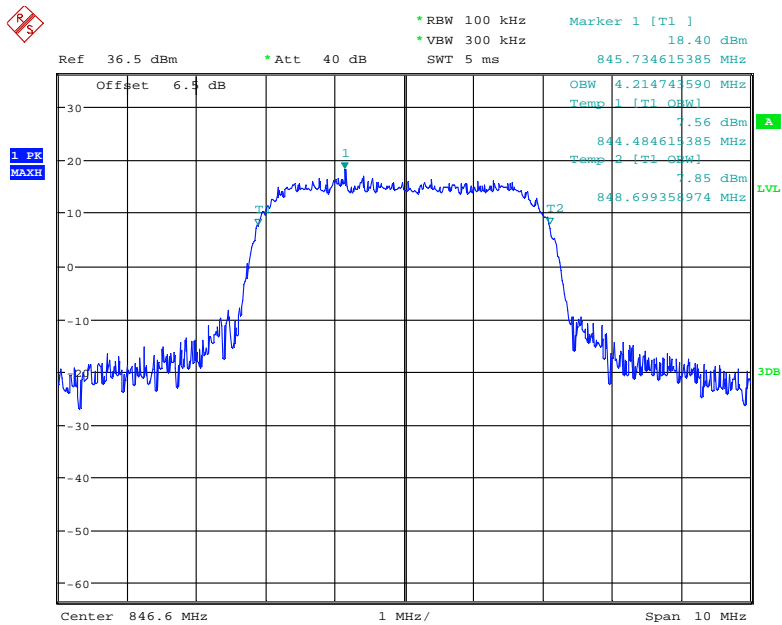

Date: 17.NOV.2020 15:32:07

PCS Band (Part 24E)

26 dB Emissions & 99% Occupied Bandwidth for GSM (GMSK) Mode, Low channel

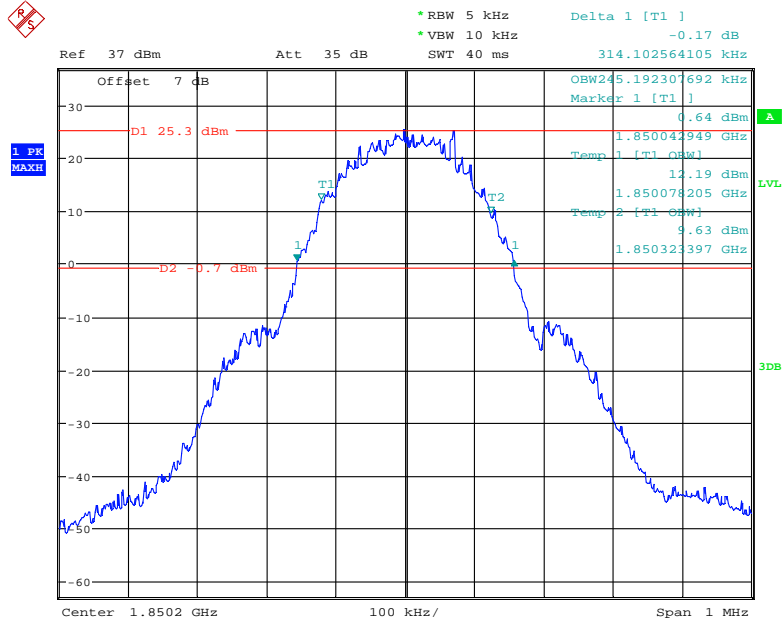

Date: 9.NOV.2020 10:46:25

26 dB Emissions & 99% Occupied Bandwidth for GSM (GMSK) Mode, Middle channel

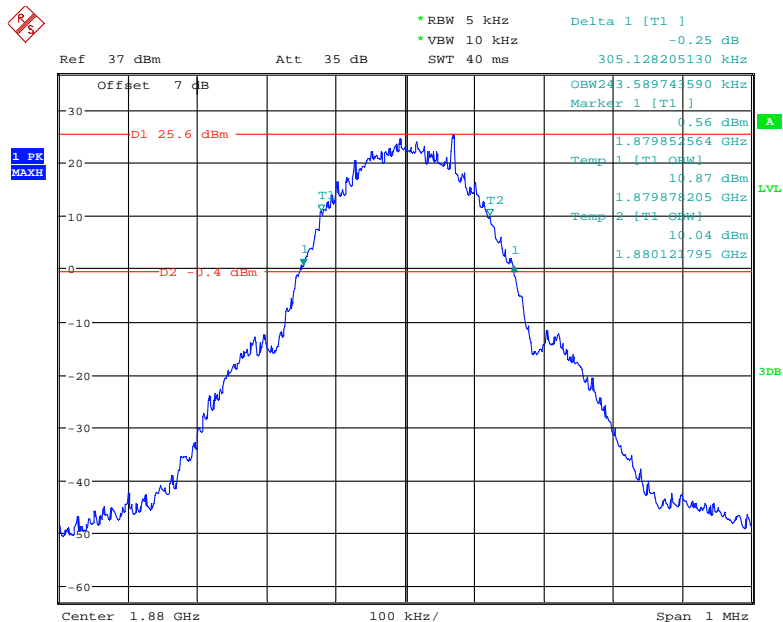

Date: 9.NOV.2020 10:48:43

26 dB Emissions & 99% Occupied Bandwidth for GSM (GMSK) Mode, High channel

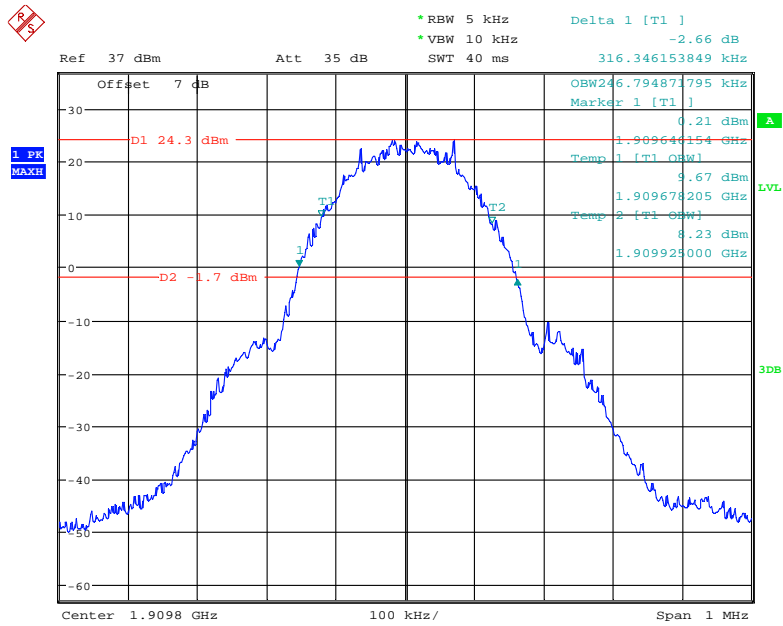

Date: 9.NOV.2020 10:50:43

26 dB Emissions & 99% Occupied Bandwidth for EGPRS (8PSK) Mode, Low channel

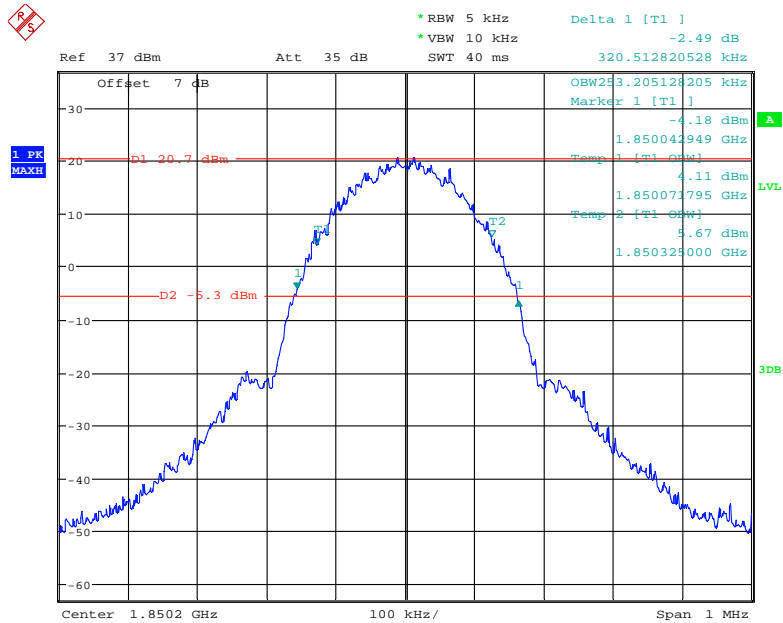

Date: 22.NOV.2020 11:30:10

26 dB Emissions & 99% Occupied Bandwidth for EGPRS (8PSK) Mode, Middle channel

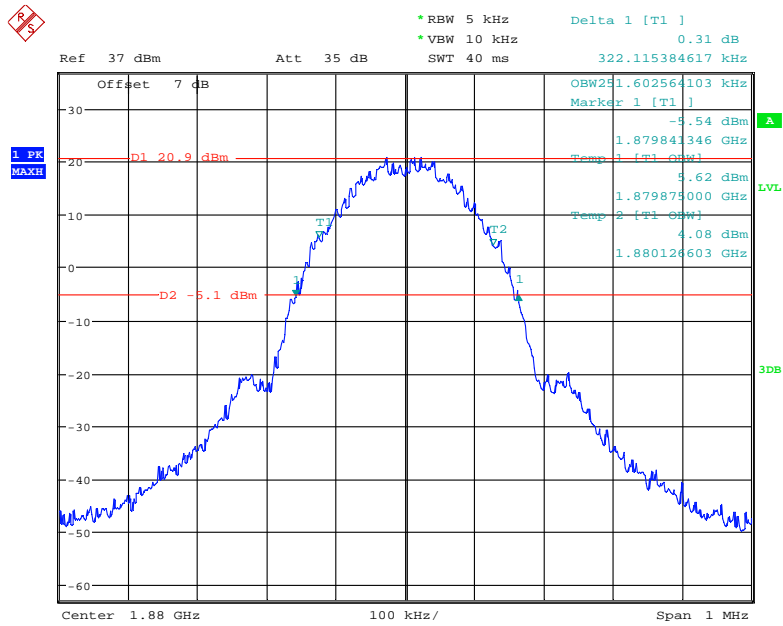

Date: 9.NOV.2020 10:42:22

26 dB Emissions & 99% Occupied Bandwidth for EGPRS (8PSK) Mode, High channel

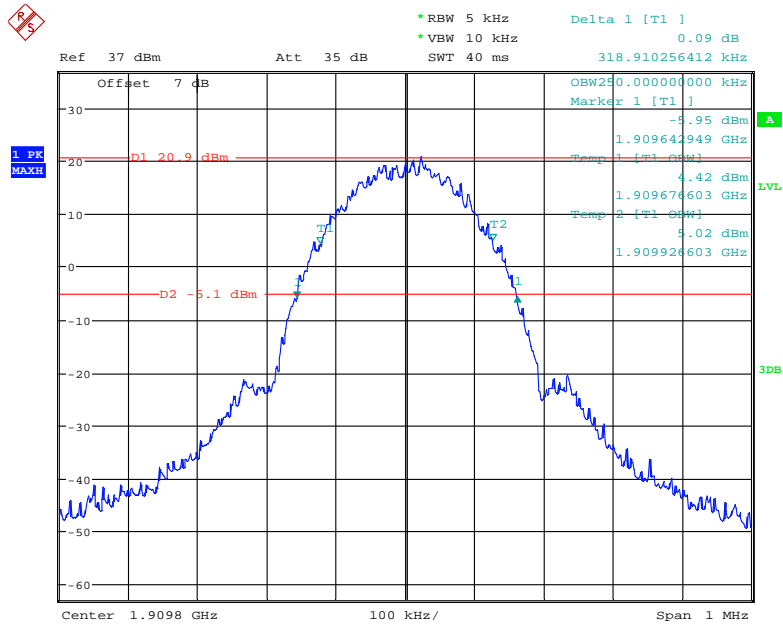

Date: 9.NOV.2020 10:39:24

26 dB Emissions Bandwidth for RMC (BPSK) Mode, Low channel

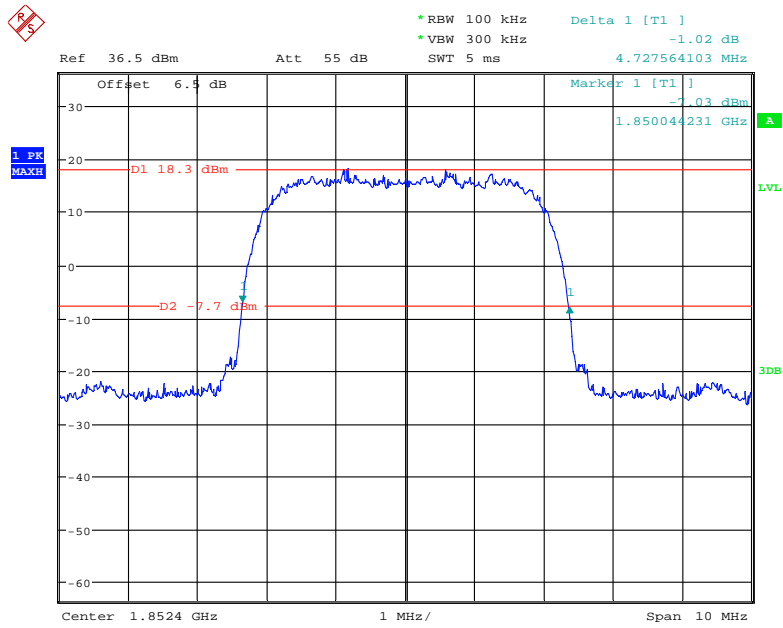

Date: 17.NOV.2020 14:43:53

26 dB Emissions Bandwidth for RMC (BPSK) Mode, Middle channel

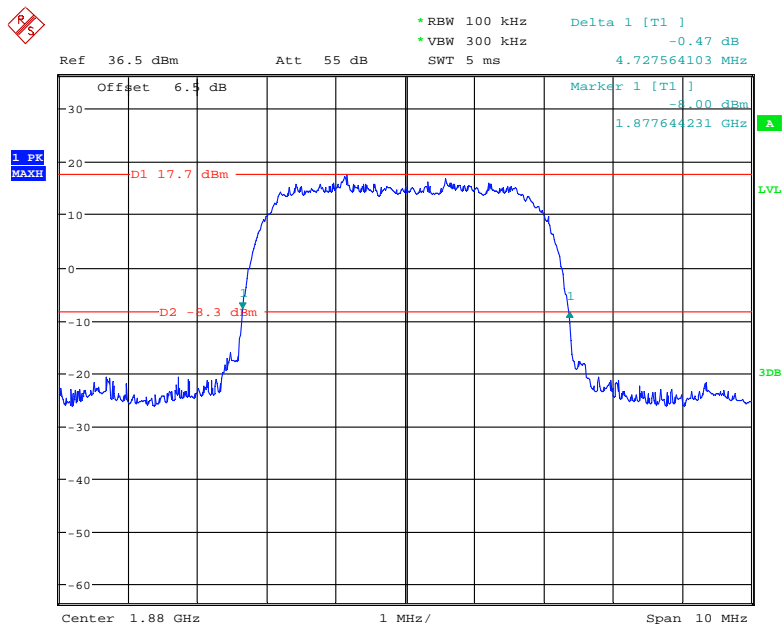

Date: 17.NOV.2020 14:47:52

26 dB Emissions Bandwidth for RMC (BPSK) Mode, High channel

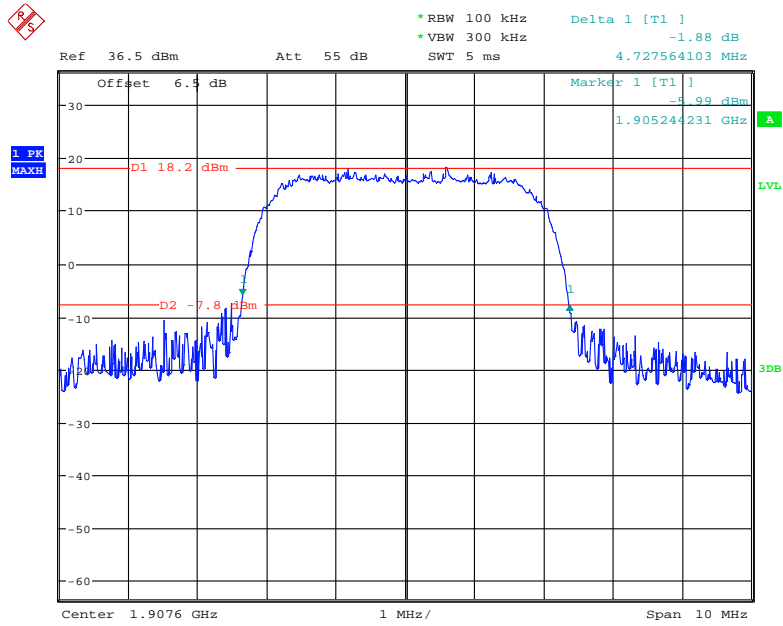

Date: 17.NOV.2020 14:38:38

26 dB Emissions Bandwidth for HSUPA (BPSK) Mode, Low channel

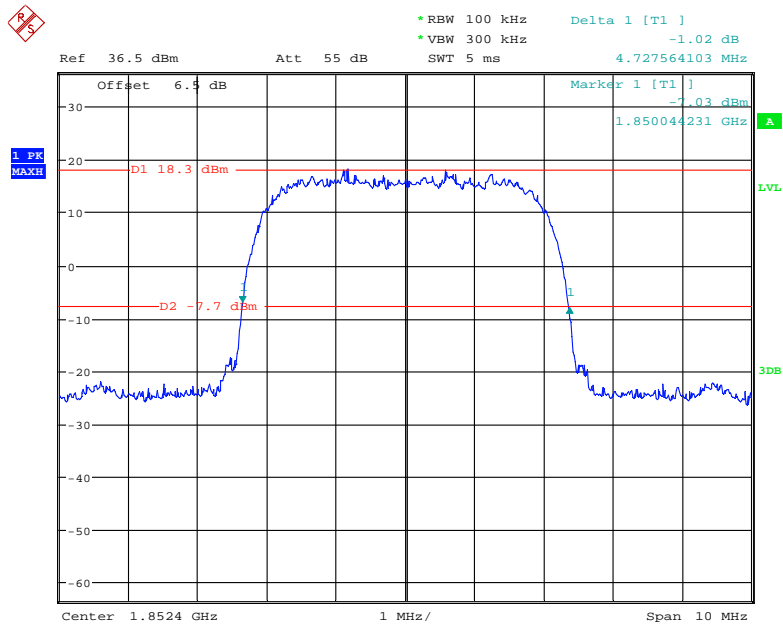

Date: 17.NOV.2020 14:43:49

26 dB Emissions Bandwidth for HSUPA (BPSK) Mode, Middle channel

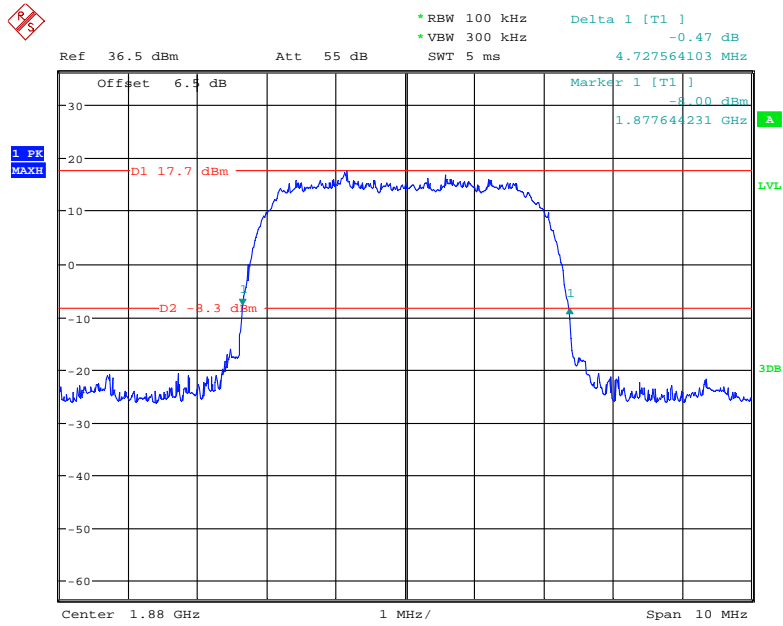

Date: 17.NOV.2020 14:47:00

26 dB Emissions Bandwidth for HSUPA (BPSK) Mode, High channel

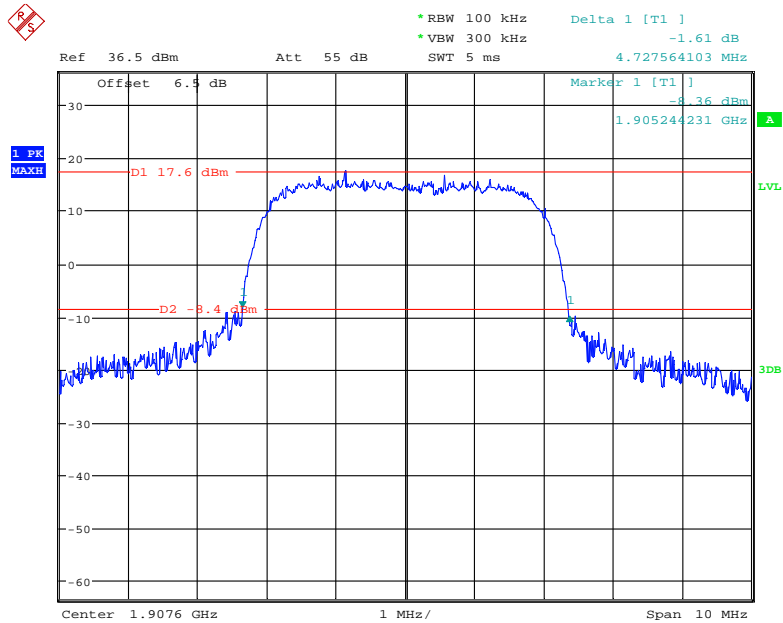

Date: 17.NOV.2020 14:49:30

26 dB Emissions Bandwidth for HSDPA (16QAM) Mode, Low channel

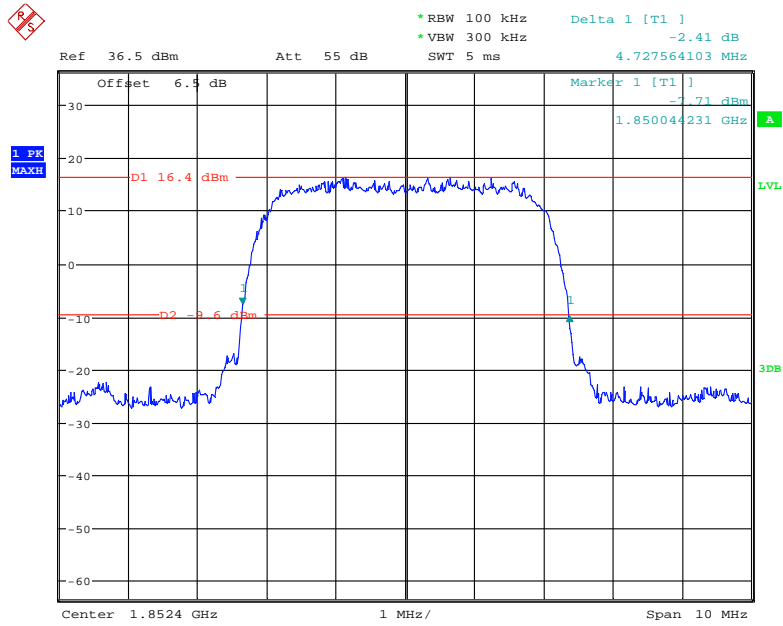

Date: 17.NOV.2020 14:54:26

26 dB Emissions Bandwidth for HSDPA (16QAM) Mode, Middle channel

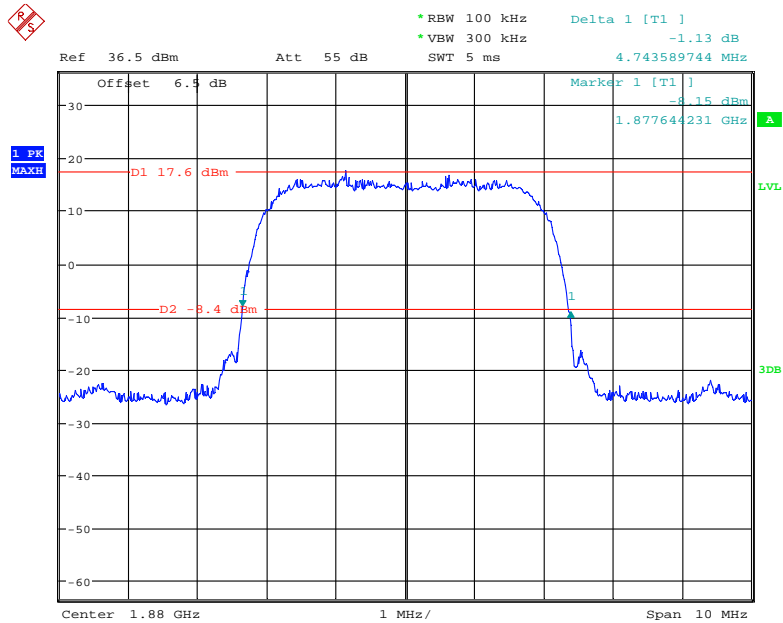

Date: 17.NOV.2020 14:53:29

26 dB Emissions Bandwidth for HSDPA (16QAM) Mode, High channel

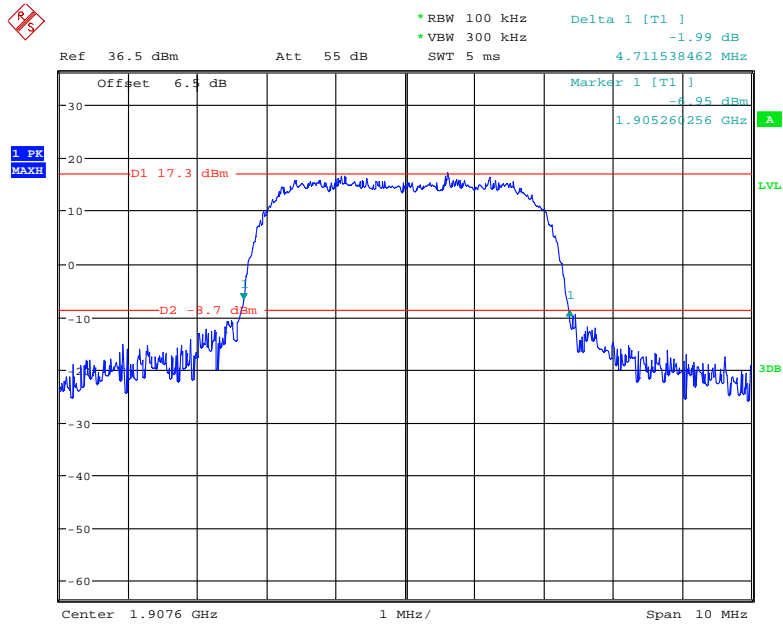

Date: 17.NOV.2020 14:52:19

99% Occupied Bandwidth for RMC (BPSK) Mode, Low channel

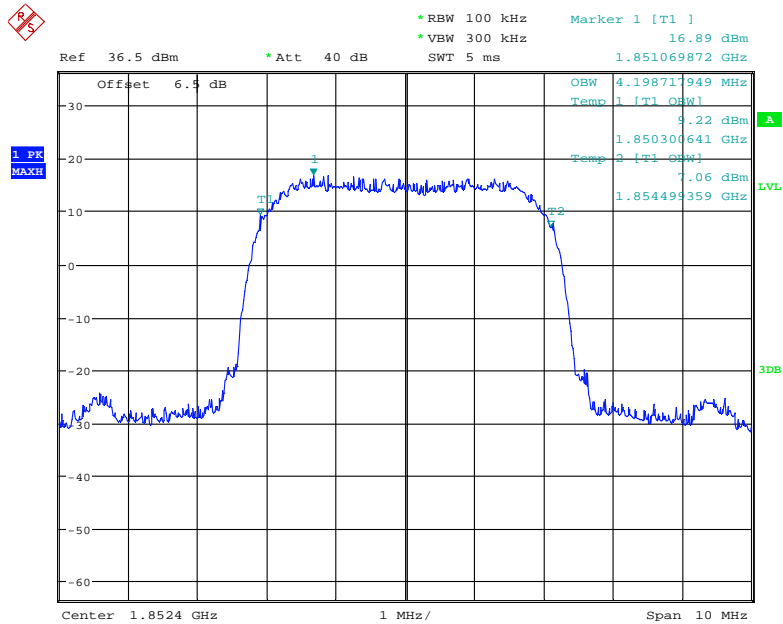

Date: 17.NOV.2020 16:08:01

99% Occupied Bandwidth for RMC (BPSK) Mode, Middle channel

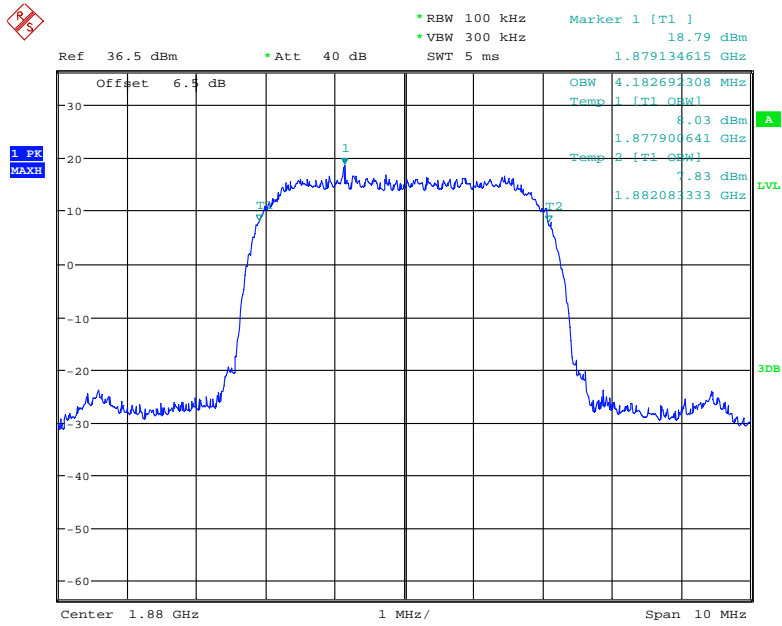

Date: 17.NOV.2020 16:07:01

99% Occupied Bandwidth for RMC (BPSK) Mode, High channel

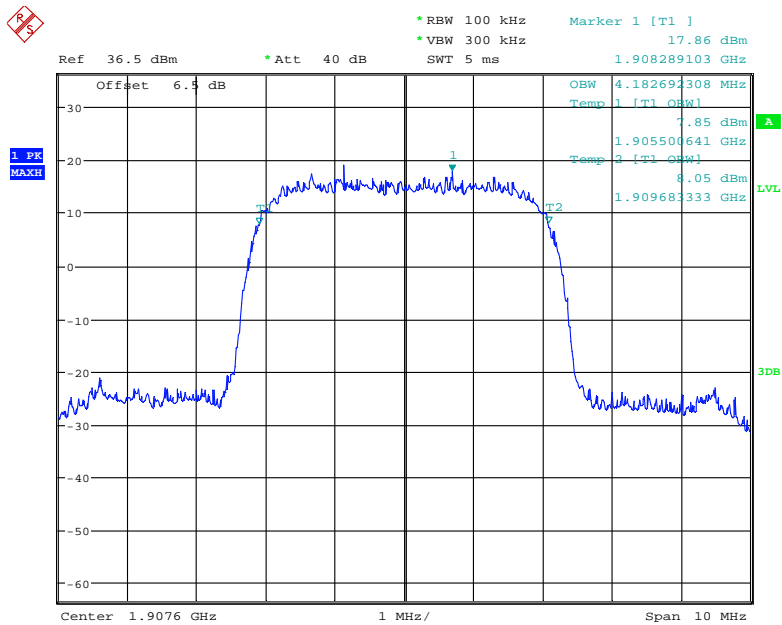

Date: 17.NOV.2020 16:06:25

99% Occupied Bandwidth for HSUPA (BPSK) Mode, Low channel

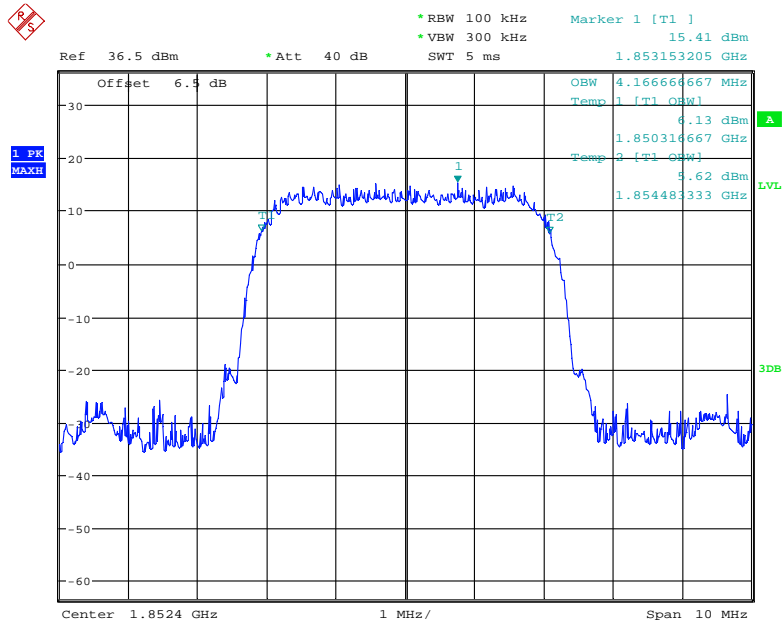

Date: 17.NOV.2020 16:17:32

99% Occupied Bandwidth for HSUPA (BPSK) Mode, Middle channel

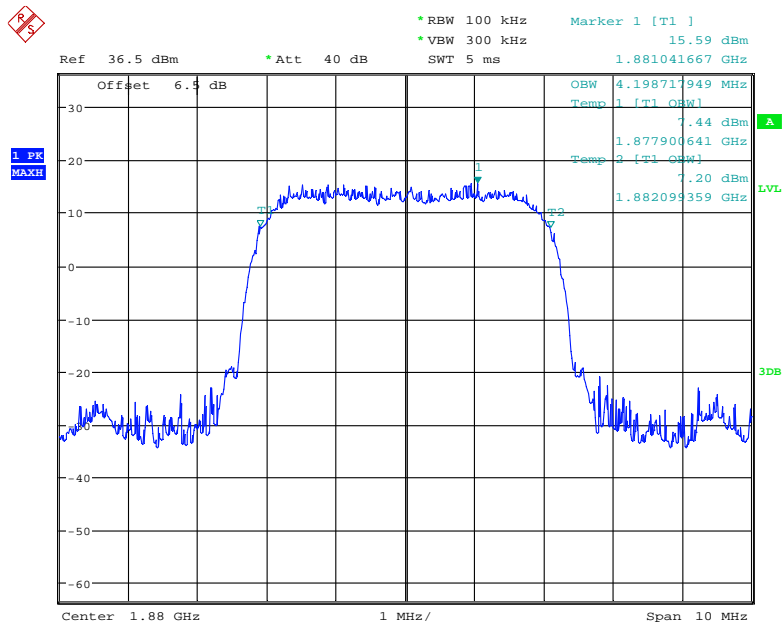

Date: 17.NOV.2020 16:17:05

99% Occupied Bandwidth for HSUPA(BPSK) Mode, High channel

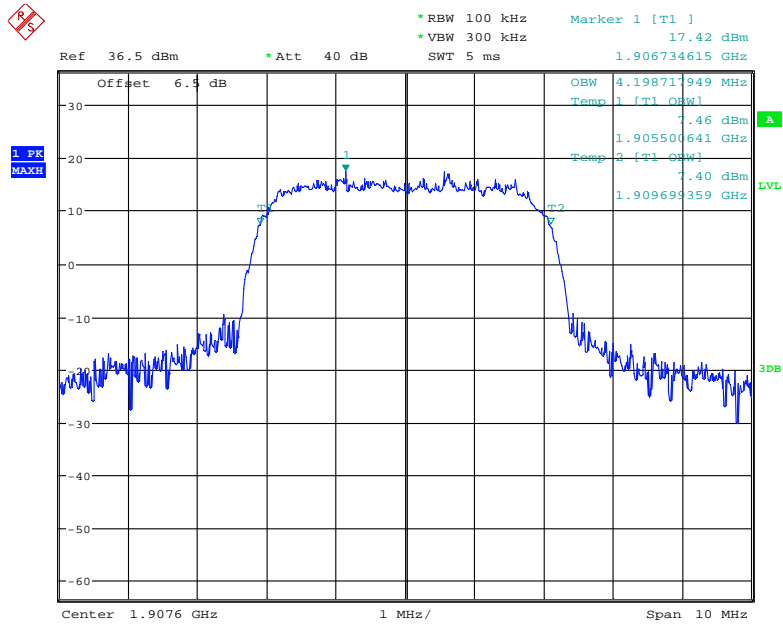

Date: 17.NOV.2020 16:16:34

99% Occupied Bandwidth for HSDPA (16QAM) Mode, Low channel

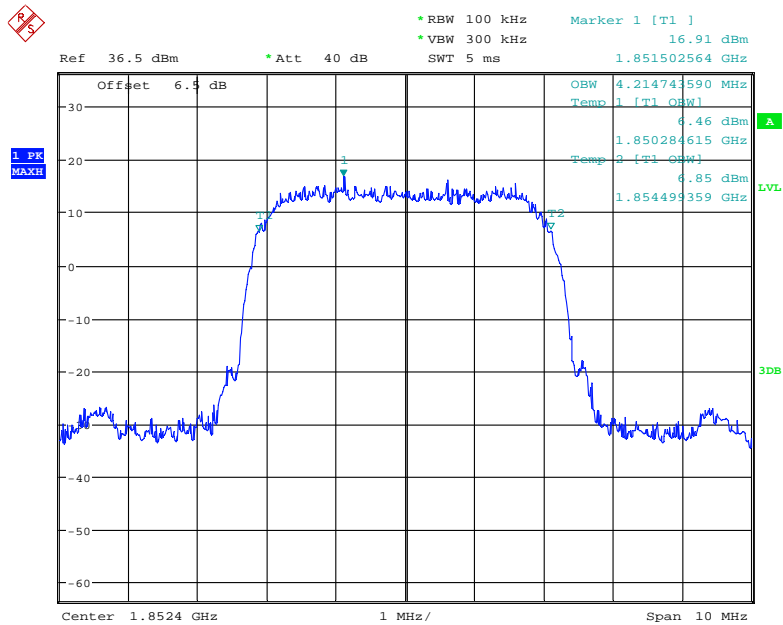

Date: 17.NOV.2020 16:08:30

99% Occupied Bandwidth for HSDPA (16QAM) Mode, Middle channel

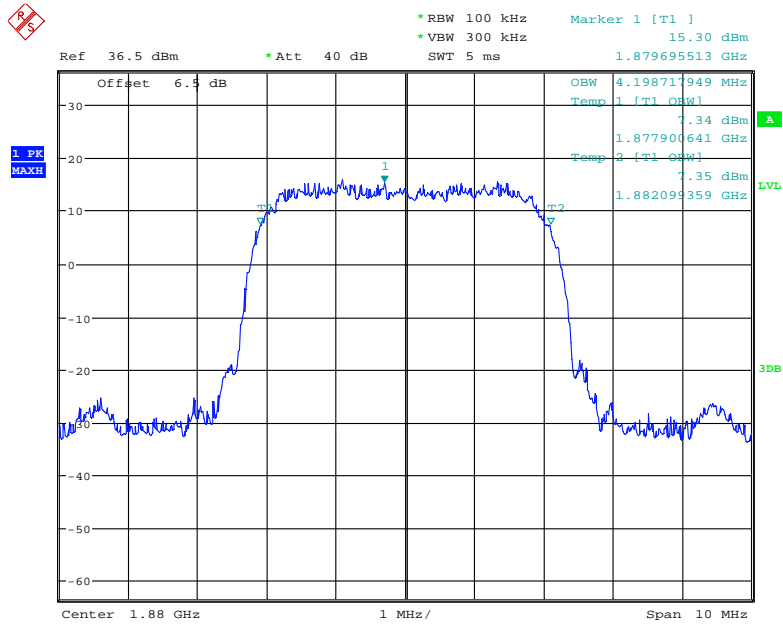

Date: 17.NOV.2020 16:08:58

99% Occupied Bandwidth for HSDPA (16QAM) Mode, High channel

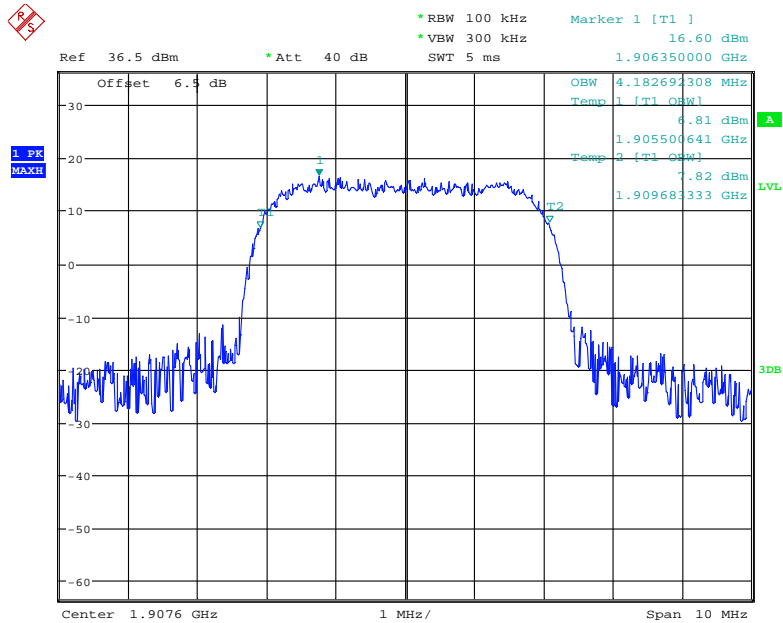

Date: 17.NOV.2020 16:09:43

AWS Band (Part 27)

26 dB Emissions Bandwidth for RMC (BPSK) Mode, Low channel

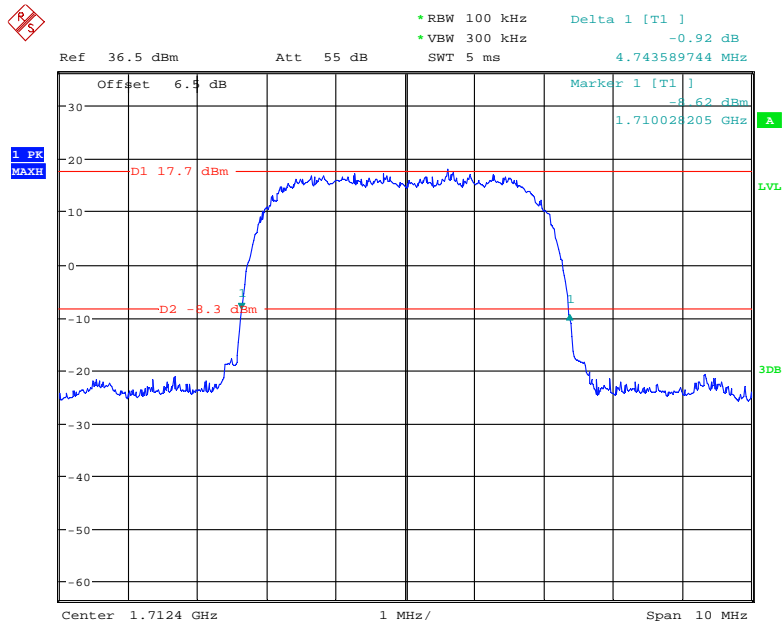

Date: 17.NOV.2020 14:56:44

26 dB Emissions for RMC (BPSK) Mode, Middle channel

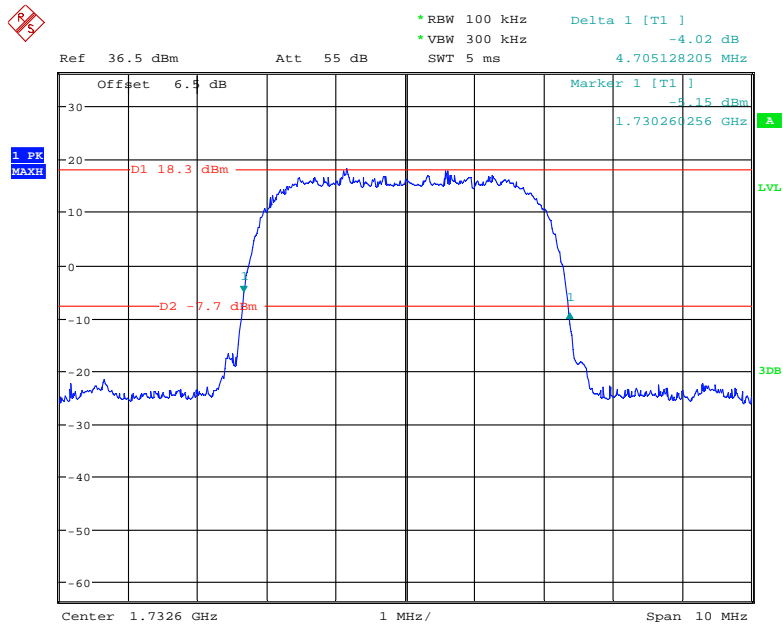

Date: 17.NOV.2020 14:58:05

26 dB Emissions Bandwidth for RMC (BPSK) Mode, High channel

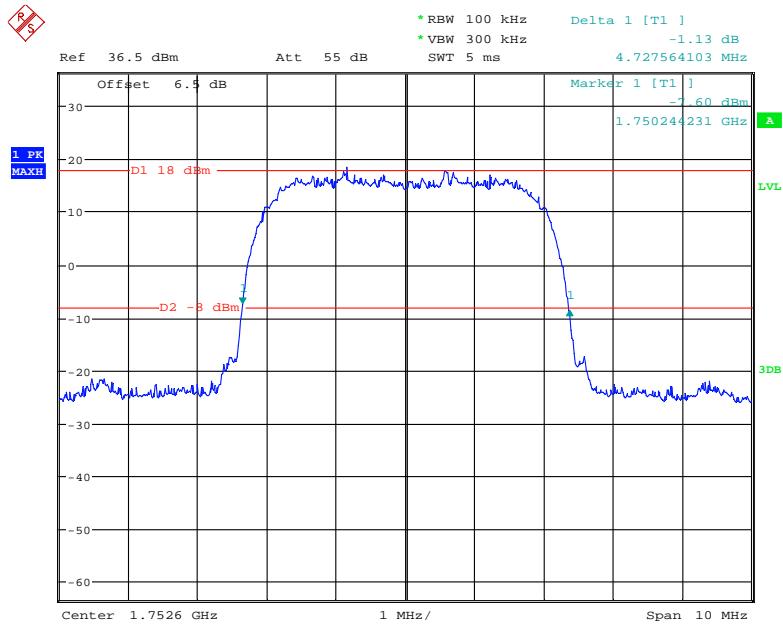

Date: 17.NOV.2020 14:59:00

26 dB Emissions Bandwidth for HSUPA (BPSK) Mode, Low channel

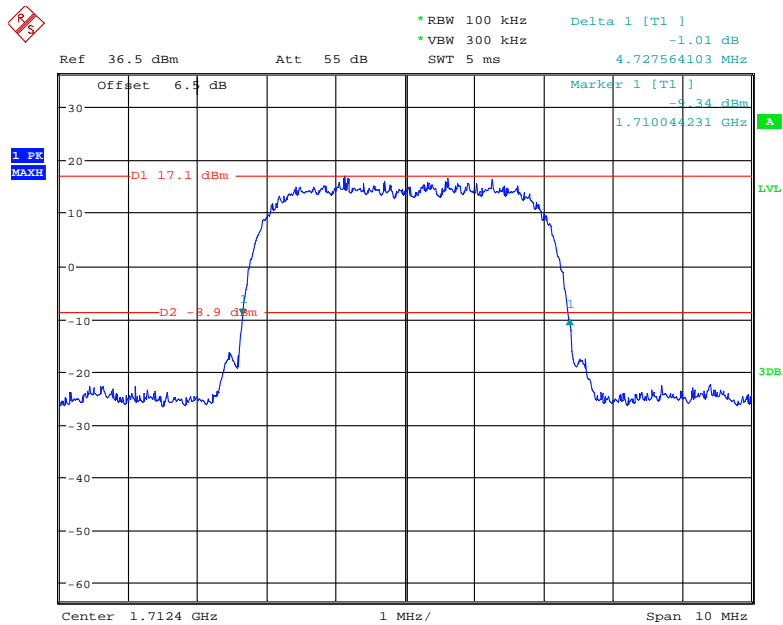

Date: 17.NOV.2020 15:05:28

26 dB Emissions Bandwidth for HSUPA (BPSK) Mode, Middle channel

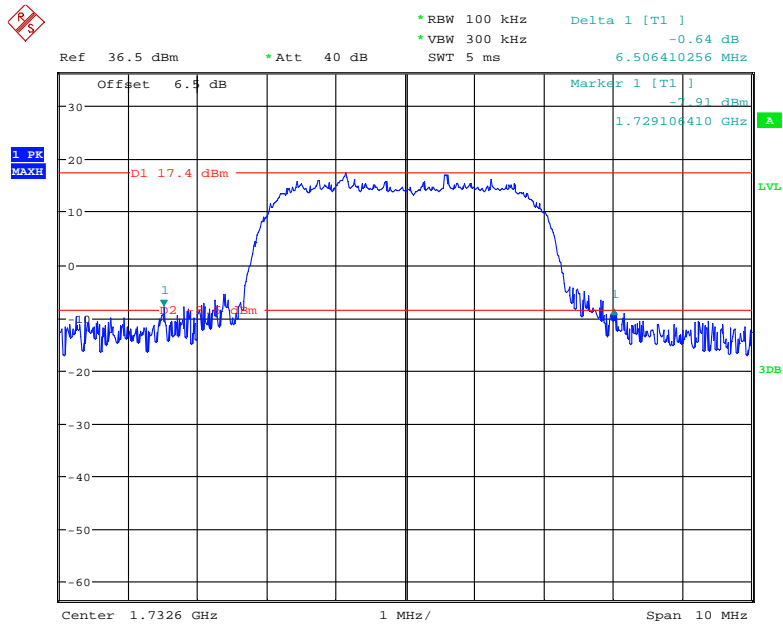

Date: 17.NOV.2020 15:10:24

26 dB Emissions for HSUPA (BPSK) Mode, High channel

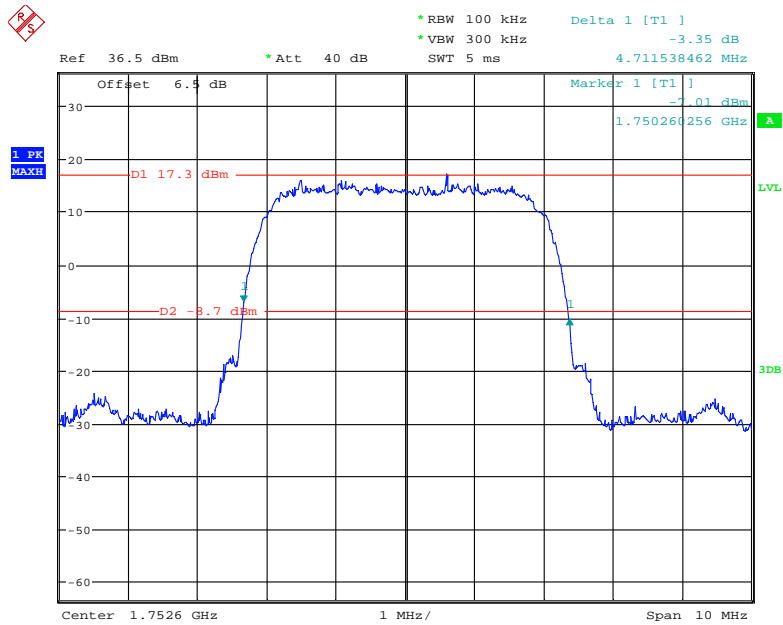

Date: 17.NOV.2020 15:11:35

26 dB Emissions Bandwidth for HSDPA (16QAM) Mode, Low channel

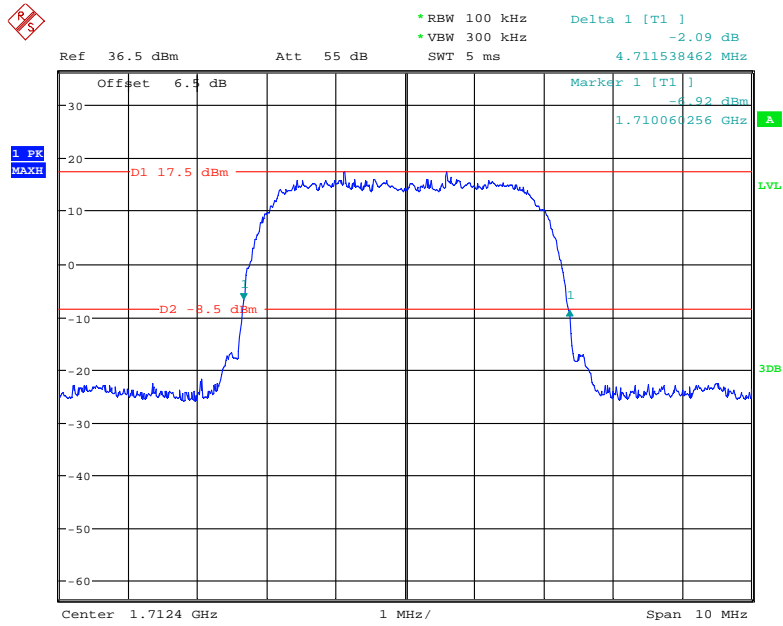

Date: 17.NOV.2020 15:03:28

26 dB Emissions Bandwidth for HSDPA (16QAM) Mode, Middle channel

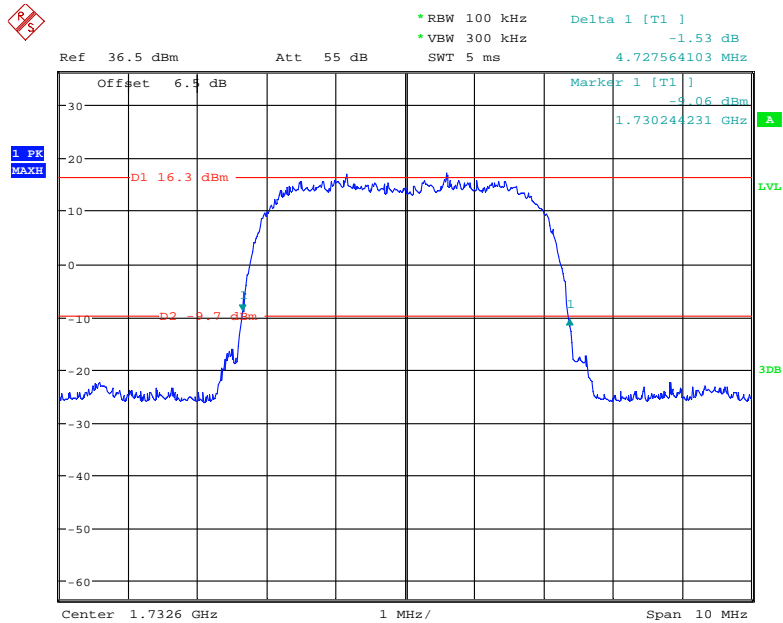

Date: 17.NOV.2020 15:01:42

26 dB Emissions Bandwidth for HSDPA (16QAM) Mode, High channel

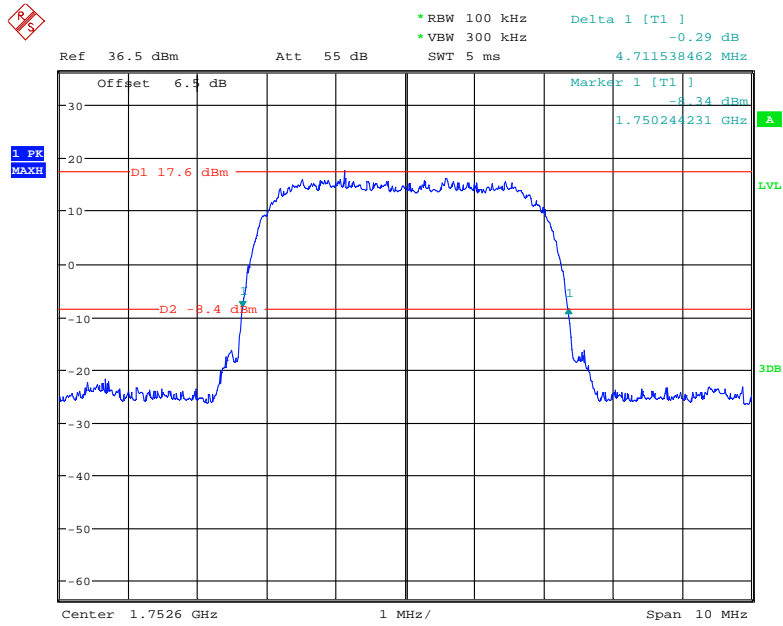

Date: 17.NOV.2020 15:00:26

99% Occupied Bandwidth for RMC (BPSK) Mode, Low channel

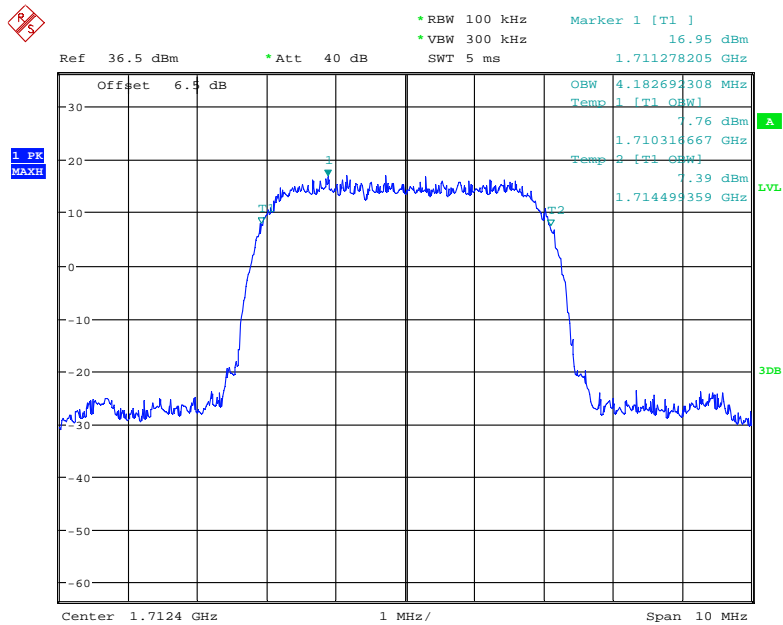

Date: 17.NOV.2020 15:50:38

99% Occupied Bandwidth for RMC (BPSK) Mode, Middle channel

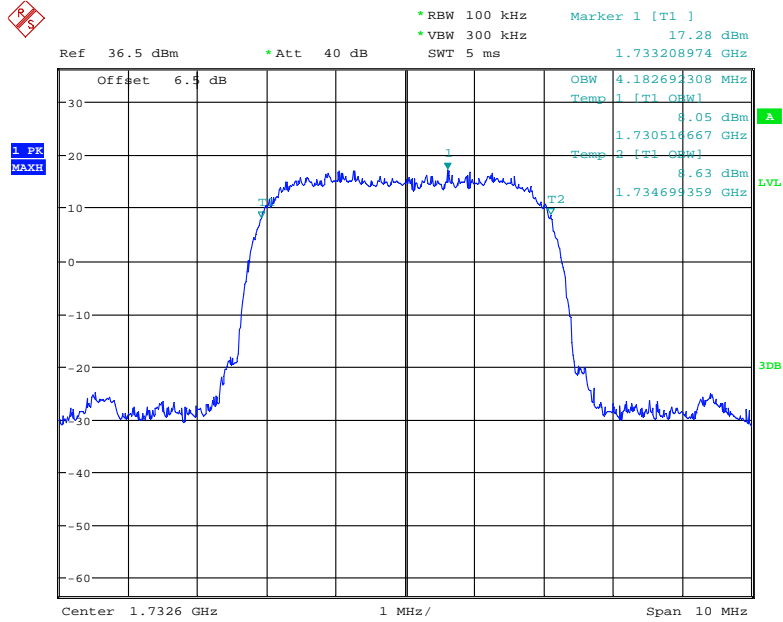

Date: 17.NOV.2020 15:50:12

99% Occupied Bandwidth for RMC (BPSK) Mode, High channel

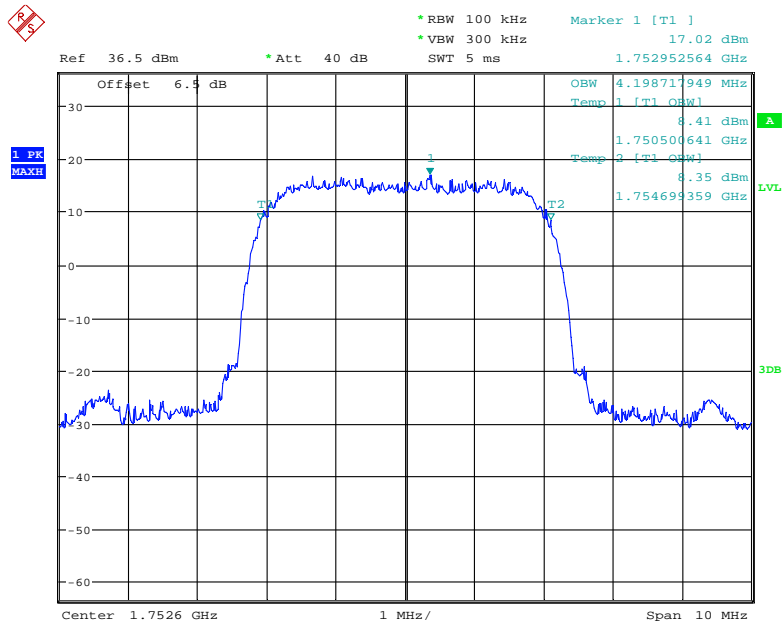

Date: 17.NOV.2020 15:49:34

99% Occupied Bandwidth for HSUPA (BPSK) Mode, Low channel

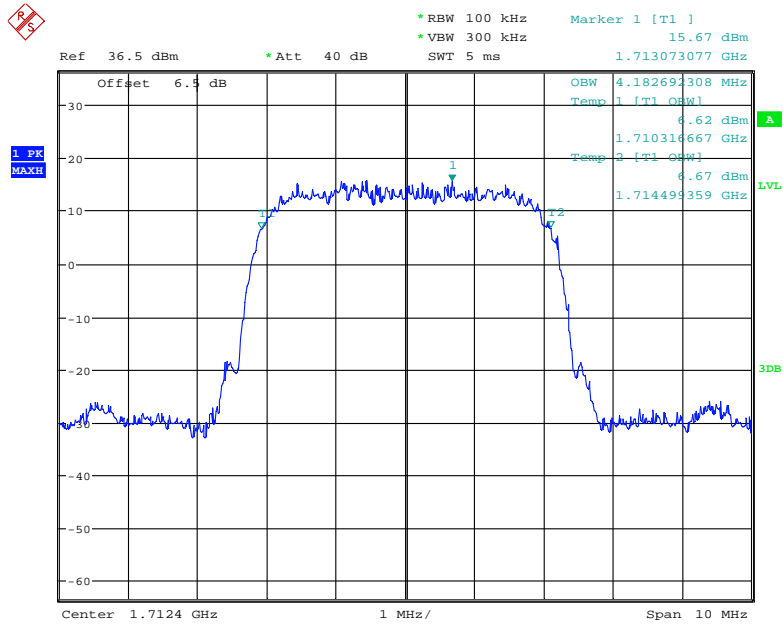

Date: 17.NOV.2020 15:56:58

99% Occupied Bandwidth for HSUPA (BPSK) Mode, Middle channel

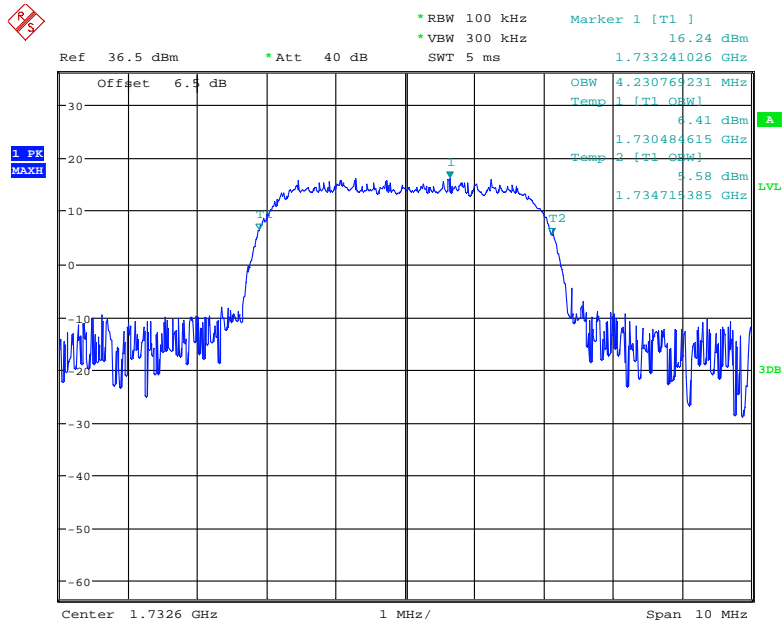

Date: 17.NOV.2020 15:57:57

99% Occupied Bandwidth for HSUPA(BPSK) Mode, High channel

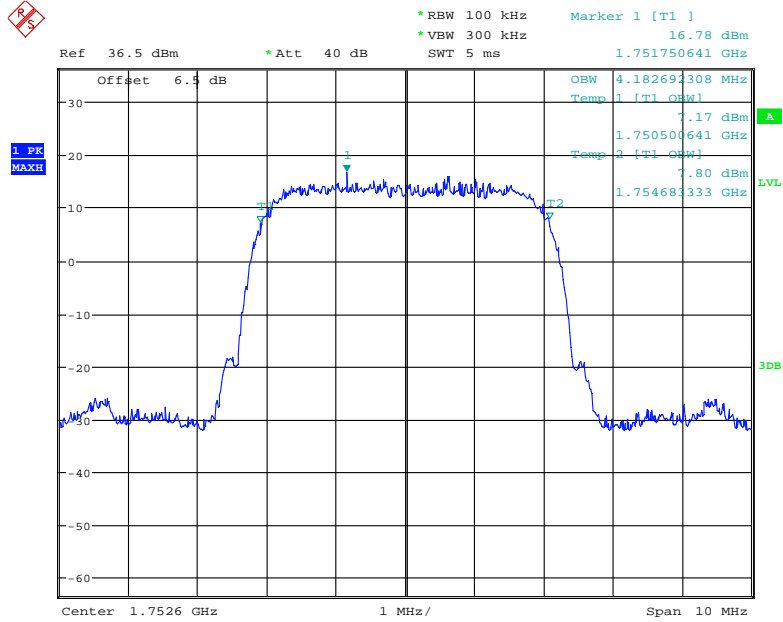

Date: 17.NOV.2020 15:58:29

99% Occupied Bandwidth for HSDPA (16QAM) Mode, Low channel

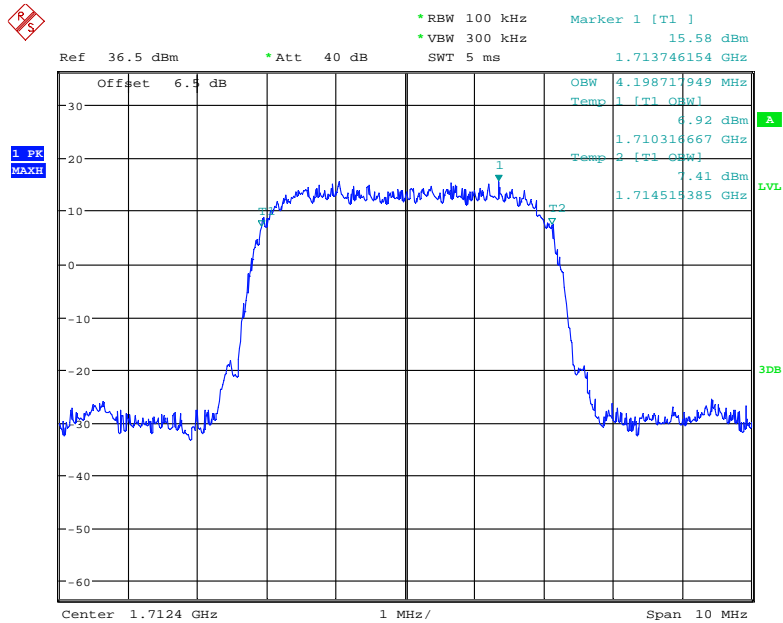

Date: 17.NOV.2020 16:00:06

99% Occupied Bandwidth for HSDPA (16QAM) Mode, Middle channel

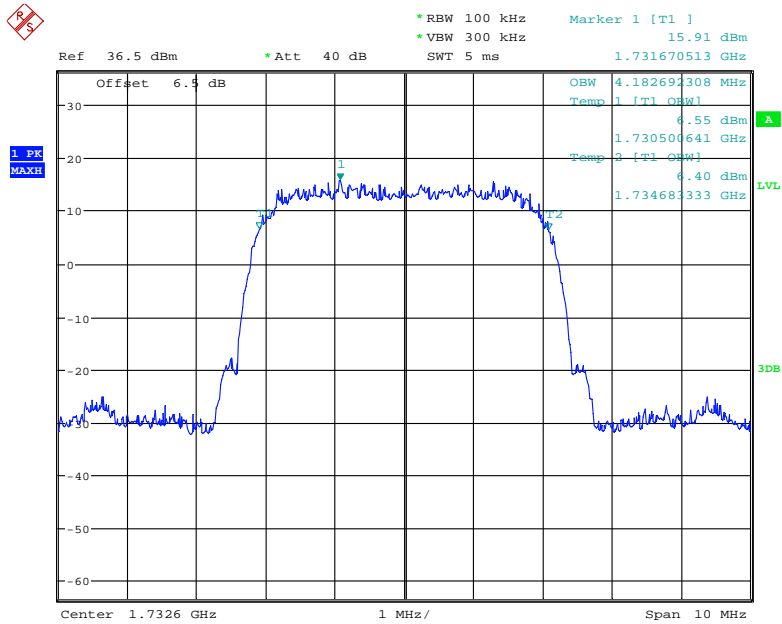

Date: 17.NOV.2020 15:59:41

99% Occupied Bandwidth for HSDPA (16QAM) Mode, High channel

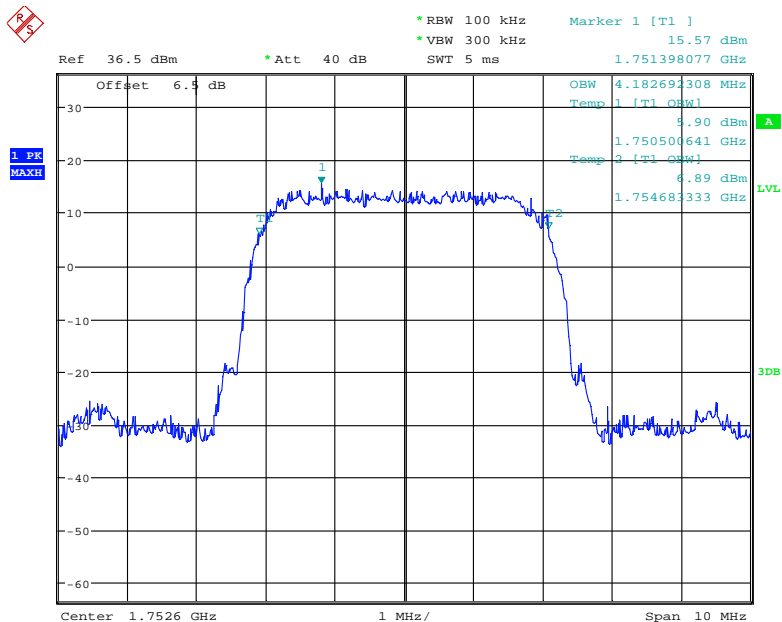

Date: 17.NOV.2020 15:59:14

LTE Band 2:

Bandwidth (MHz)	Modulation	Channel	99% Occupied Bandwidth (MHz)	26 dB Emission Bandwidth (MHz)
1.4	QPSK	Low	1.11	1.30
		Middle	1.10	1.31
		High	1.11	1.31
	16QAM	Low	1.10	1.30
		Middle	1.10	1.30
		High	1.10	1.30
3	QPSK	Low	2.69	2.89
		Middle	2.69	2.92
		High	2.68	2.87
	16QAM	Low	2.67	2.88
		Middle	2.69	2.88
		High	2.69	2.87
5	QPSK	Low	4.52	5.06
		Middle	4.52	4.94
		High	4.52	5.06
	16QAM	Low	4.52	4.95
		Middle	4.48	4.98
		High	4.50	4.95
10	QPSK	Low	8.97	9.62
		Middle	8.96	9.60
		High	8.97	9.48
	16QAM	Low	8.97	9.58
		Middle	8.96	9.52
		High	8.97	9.61
15	QPSK	Low	13.51	14.85
		Middle	13.50	14.76
		High	13.56	14.86
	16QAM	Low	13.51	14.81
		Middle	13.50	14.76
		High	13.56	14.66
20	QPSK	Low	18.01	19.49
		Middle	17.92	19.28
		High	18.01	20.08
	16QAM	Low	17.95	19.36
		Middle	18.00	19.36
		High	18.01	20.07

Please refer to following plots:

Band 2_1.4 MHz_L_16-QAM_RB6#0

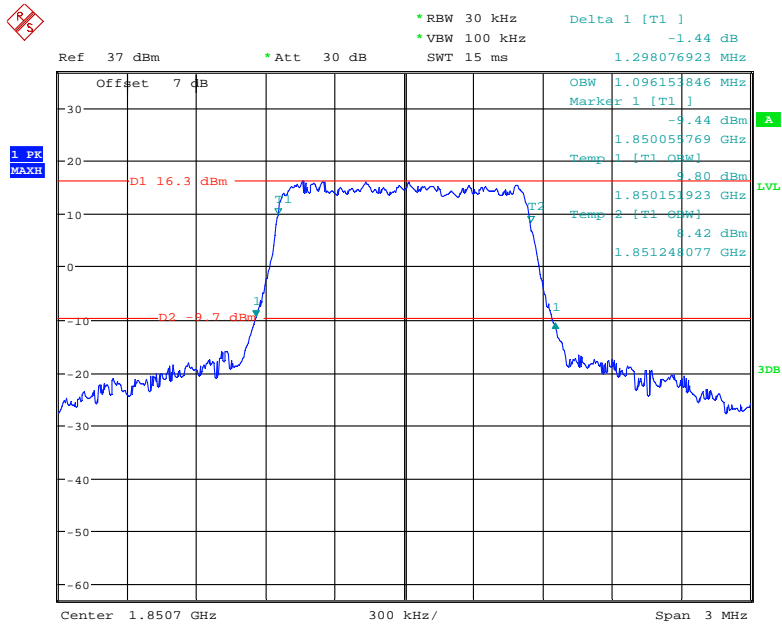

Date: 19.NOV.2020 09:33:27

Band 2_1.4 MHz_L_QPSK_RB6#0

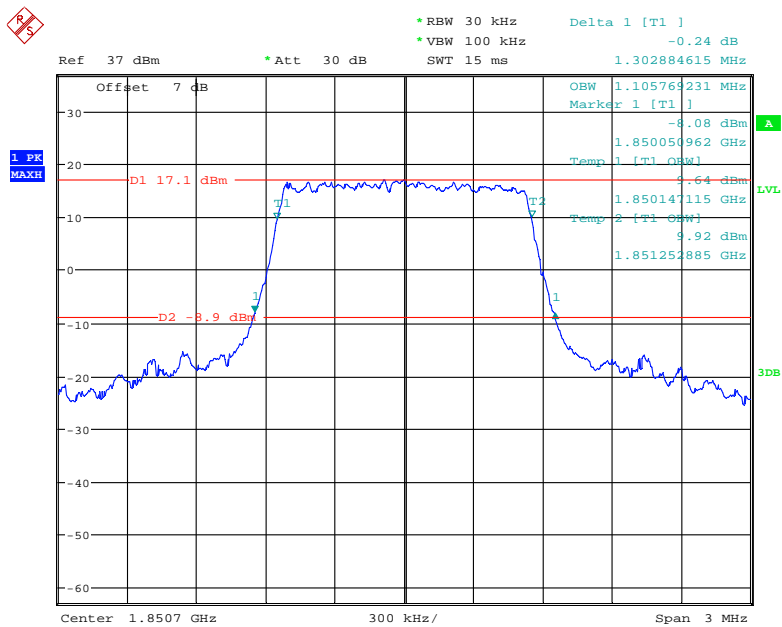

Date: 19.NOV.2020 09:32:03

Band 2_1.4 MHz_Middle_16QAM_RB6#0

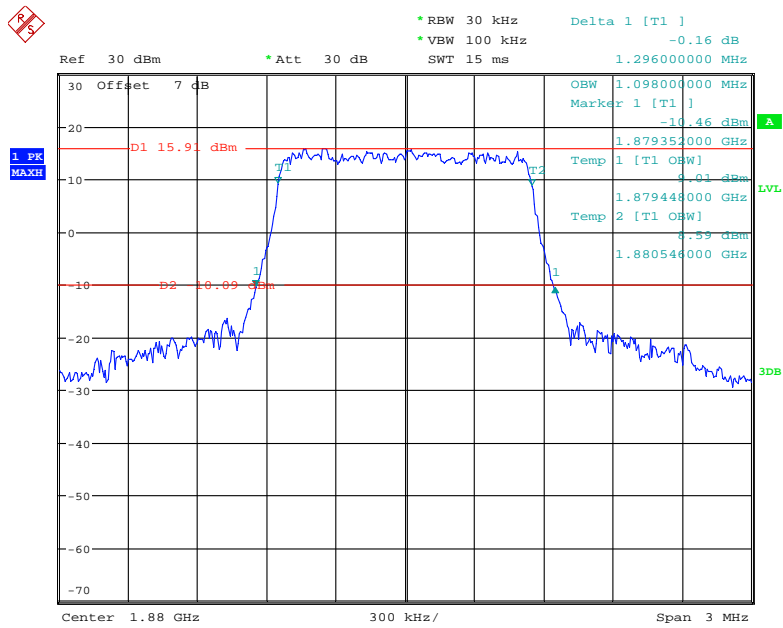

Date: 18.NOV.2020 14:26:06

Band 2_1.4 MHz_Middle_QPSK_RB6#0

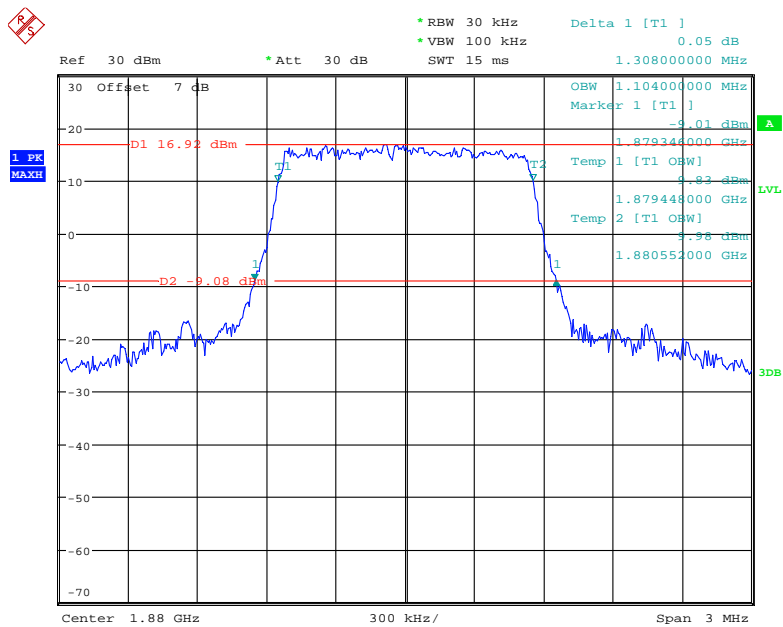

Date: 18.NOV.2020 14:25:48

Band 2_1.4 MHz_H_16-QAM_RB6#0

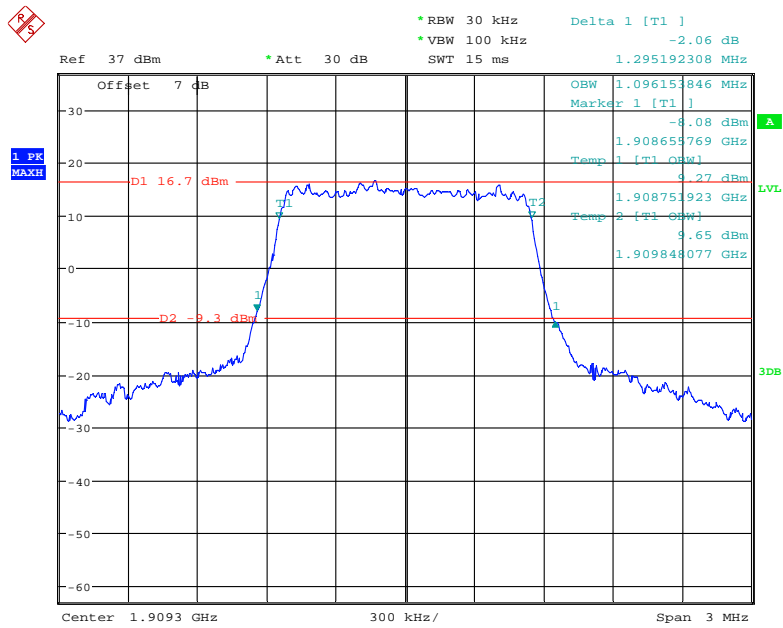

Date: 19.NOV.2020 09:34:50

Band 2_1.4 MHz_H_QPSK_RB6#0

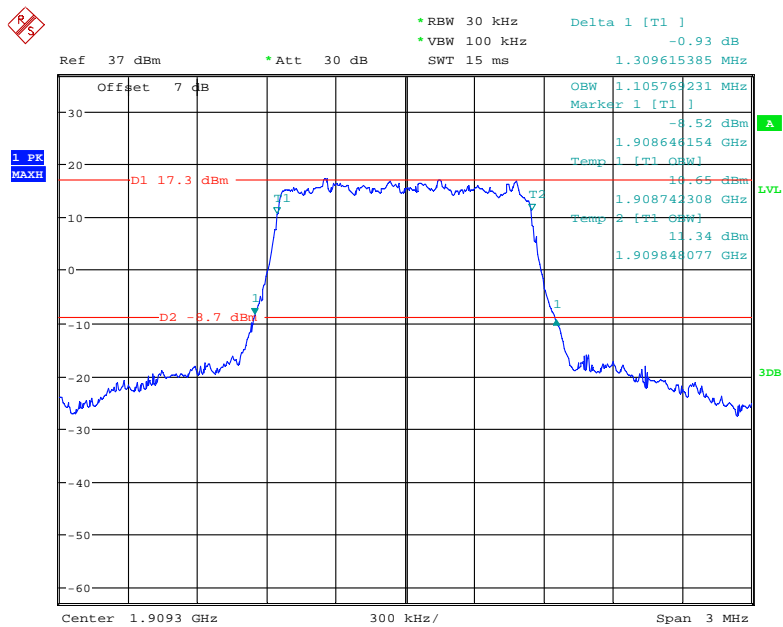

Date: 19.NOV.2020 09:35:36

Band 2_3 MHz_L_16QAM_RB15#0

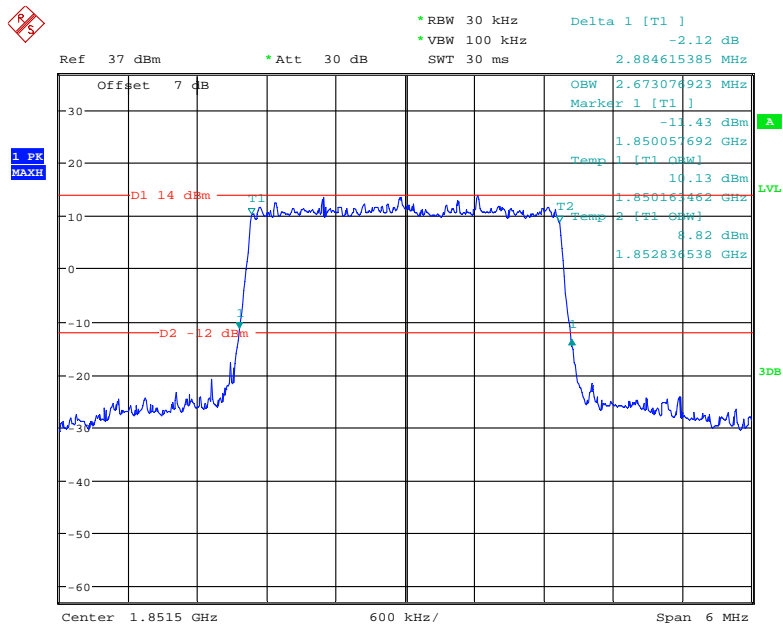

Date: 19.NOV.2020 09:38:52

Band 2_3 MHz_L_QPSK_RB15#0

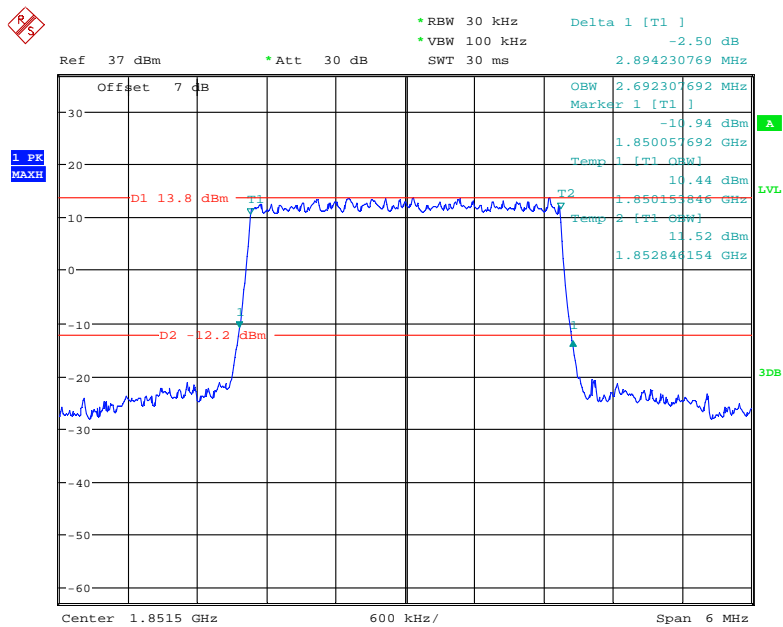

Date: 19.NOV.2020 09:37:43

Band 2_3 MHz_Middle_QPSK_RB15#0

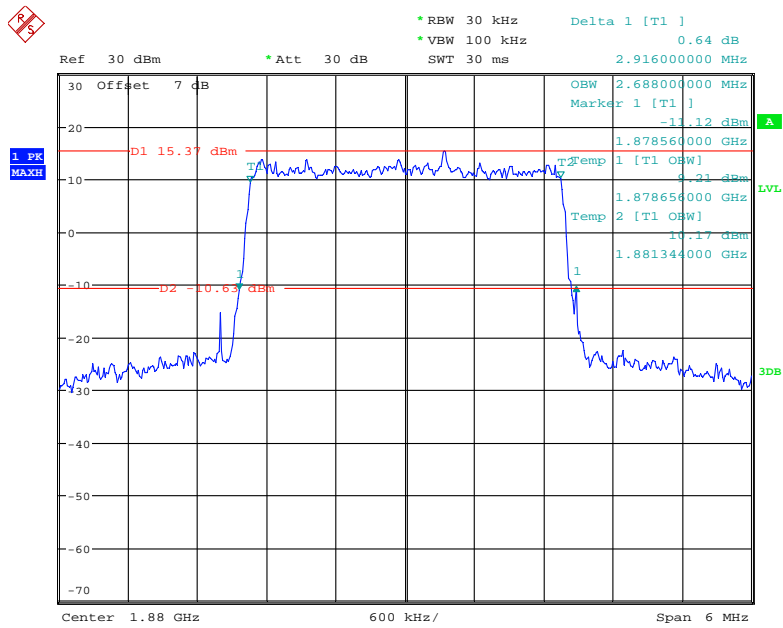

Date: 18.NOV.2020 14:26:29

Band 2_3 MHz_Middle_16QAM_RB15#0

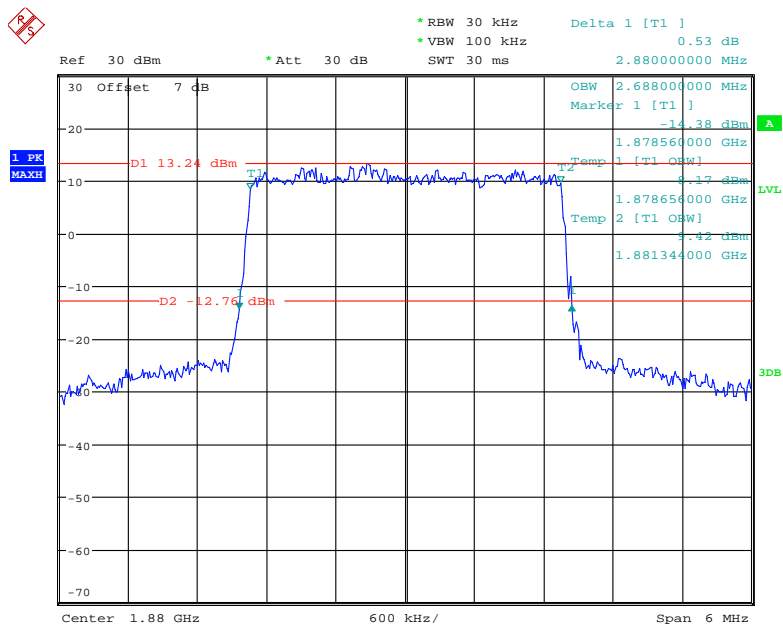

Date: 18.NOV.2020 14:26:46

Band 2_3 MHz_H_16QAM_RB15#0

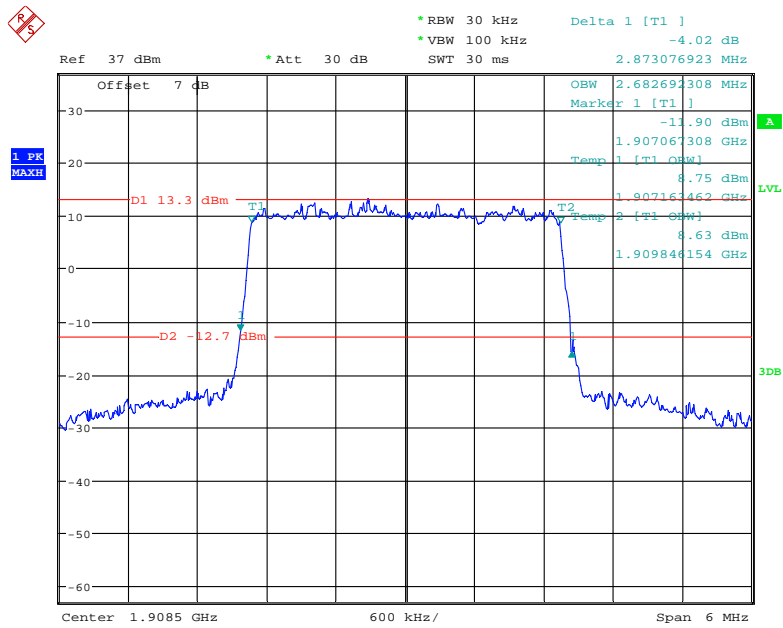

Date: 19.NOV.2020 09:41:43

Band 2_3 MHz_H_QPSK_RB15#0

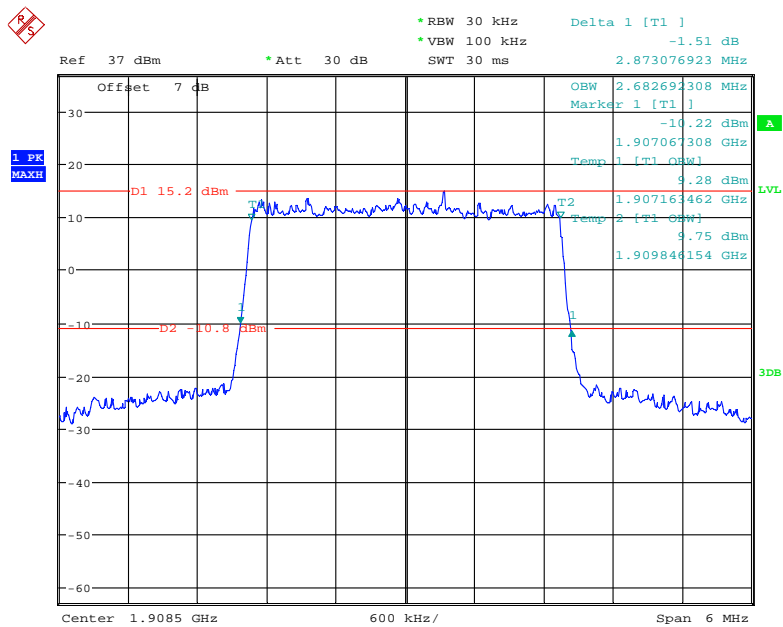

Date: 19.NOV.2020 09:40:46

Band 2_5 MHz_L_16QAM_RB25#0

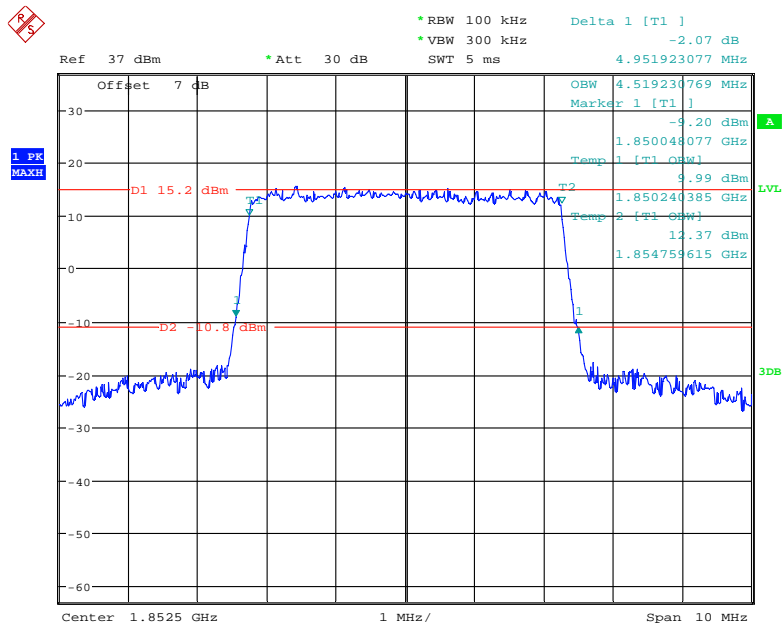

Date: 19.NOV.2020 10:02:37

Band 2_5 MHz_L_QPSK_RB25#0

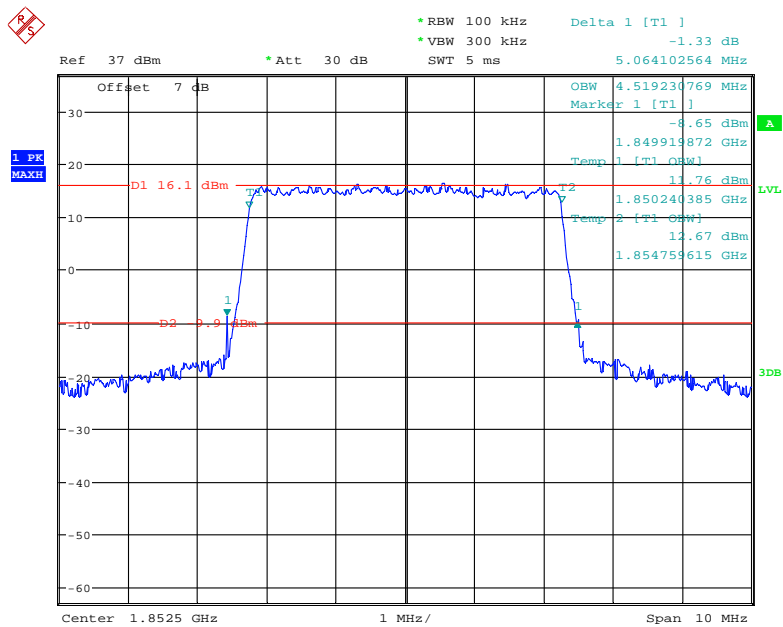

Date: 19.NOV.2020 10:03:47

Band 2_5 MHz_Middle_QPSK_RB25#0

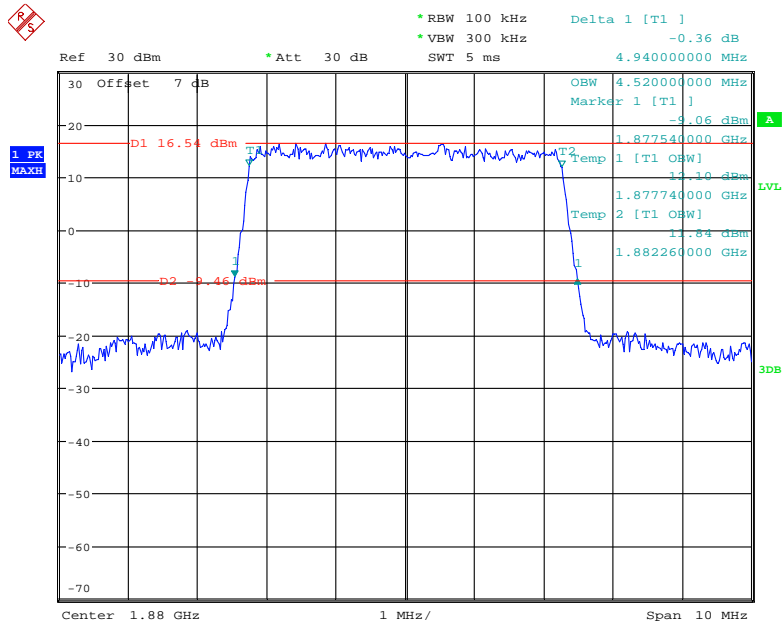

Date: 18.NOV.2020 14:27:10

Band 2_5 MHz_Middle_16QAM_RB25#0

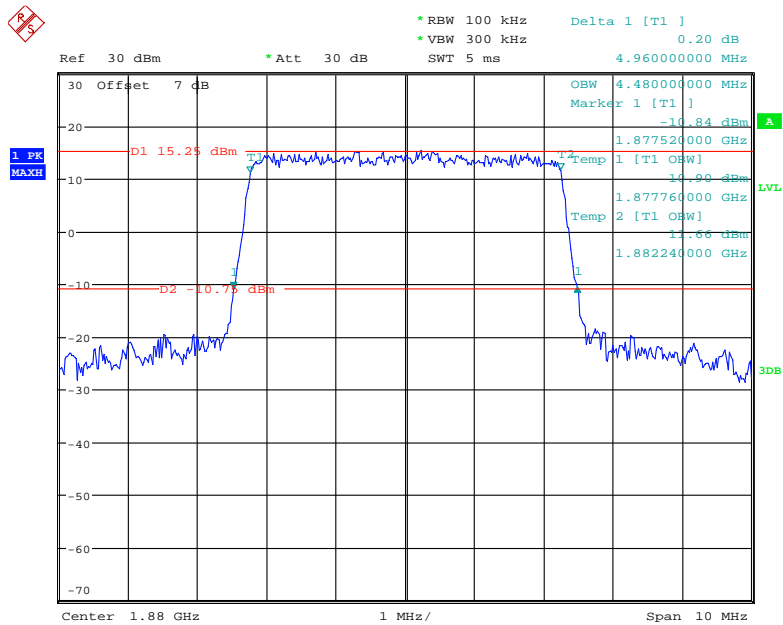

Date: 18.NOV.2020 14:27:32

Band 2_5 MHz_H_16QAM_RB25#0

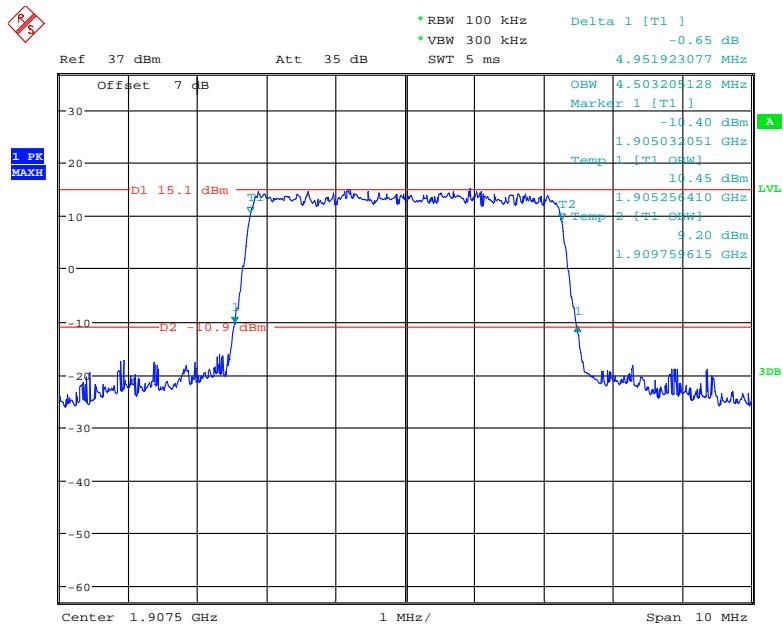

Date: 19.NOV.2020 10:10:49

Band 2_5 MHz_H_QPSK_RB25#0

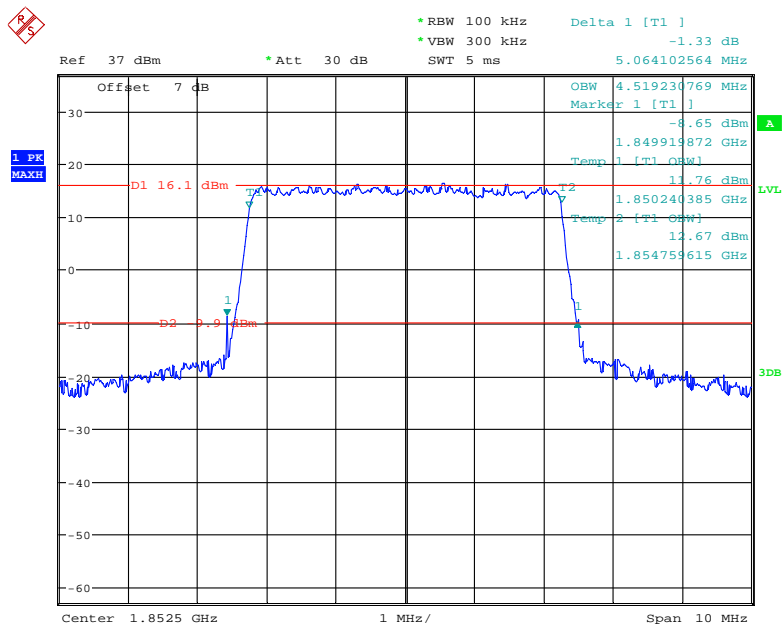

Date: 19.NOV.2020 10:03:47

Band 2_10 MHz_L_16QAM_RB50#0

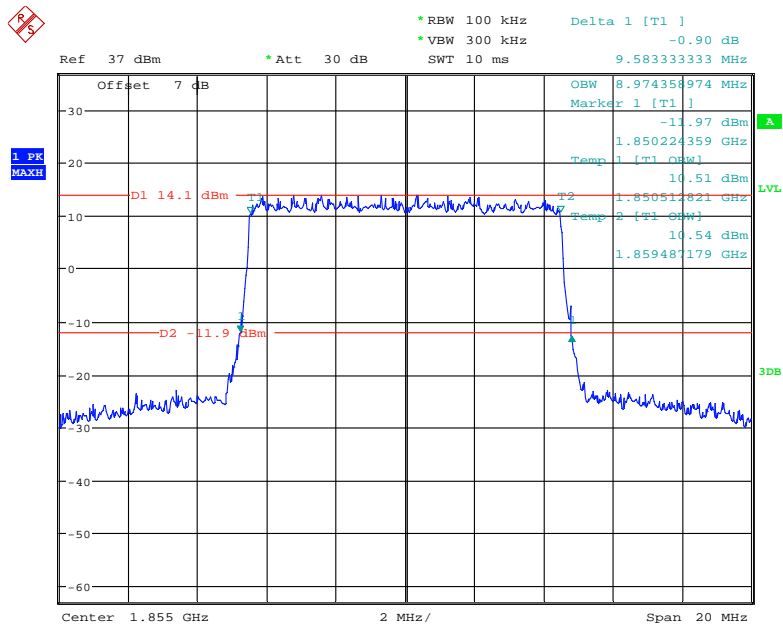

Date: 19.NOV.2020 10:00:27

Band 2_10 MHz_L_QPSK_RB50#0

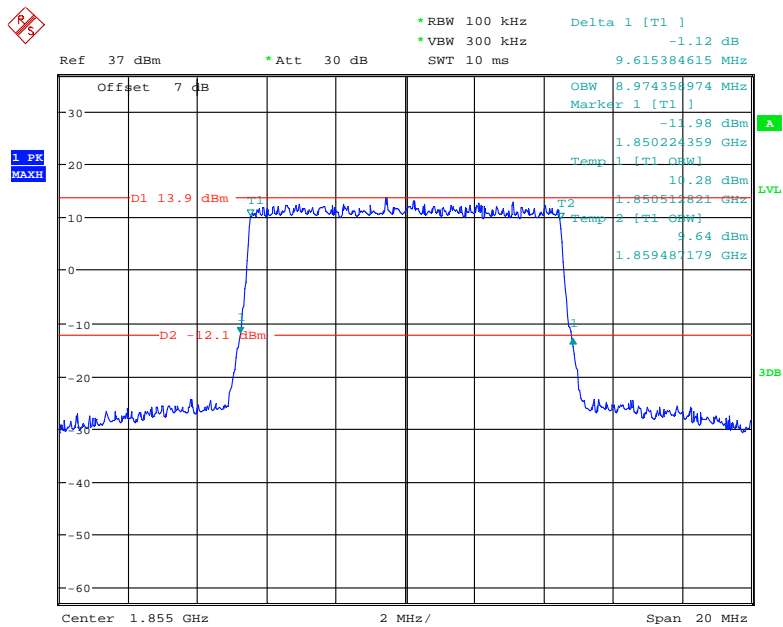

Date: 19.NOV.2020 09:59:49

Band 2_10 MHz_Middle_QPSK_RB50#0

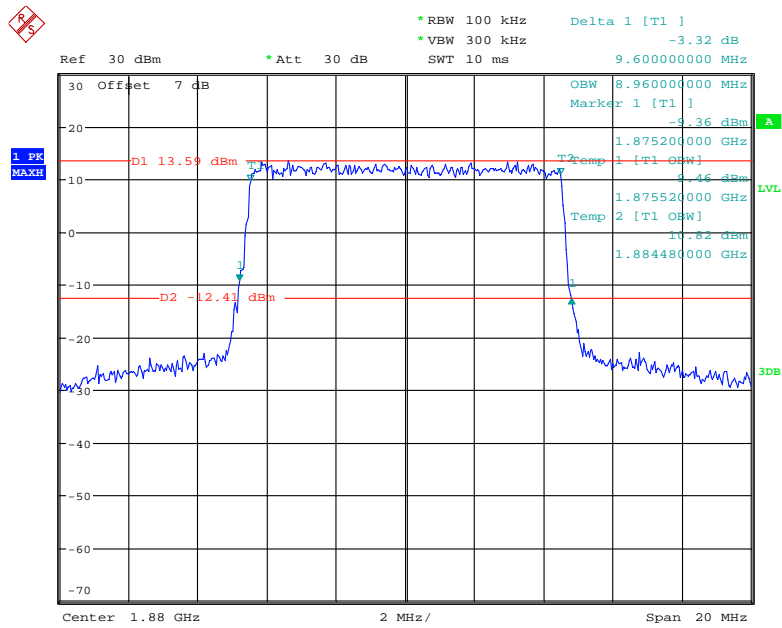

Date: 18.NOV.2020 14:27:57

Band 2_10 MHz_Middle_16QAM_RB50#0

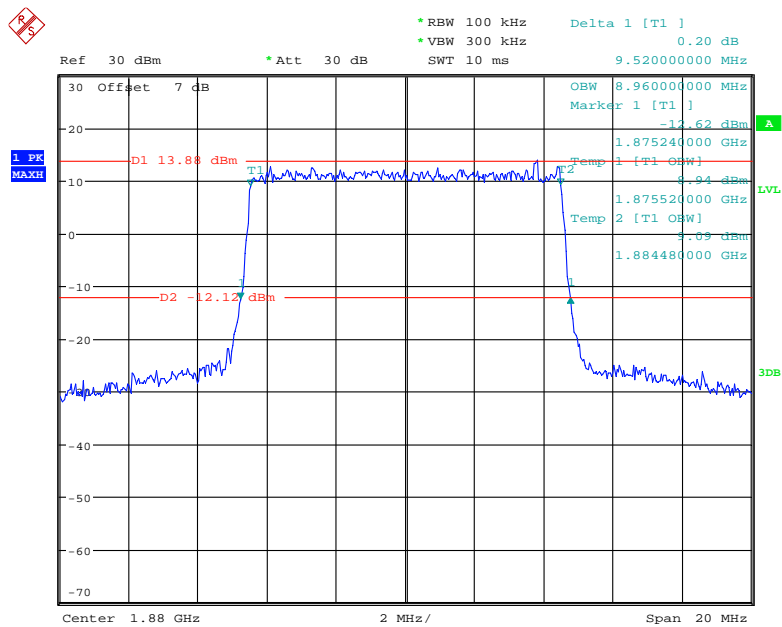

Date: 18.NOV.2020 14:28:21

Band 2_10 MHz_H_16QAM_RB50#0

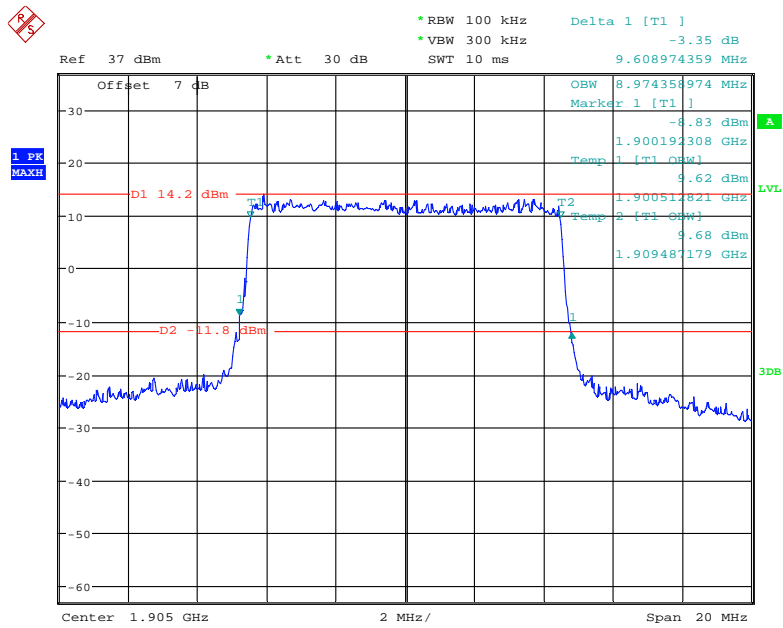

Date: 19.NOV.2020 09:56:14

Band 2_10 MHz_H_QPSK_RB50#0

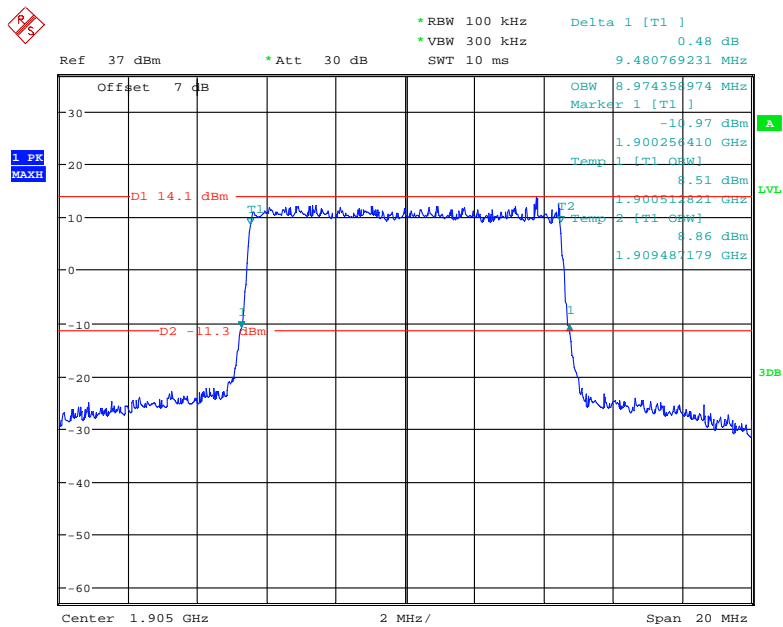

Date: 19.NOV.2020 09:55:08

Band 2_15 MHz_L_16QAM_RB75#0

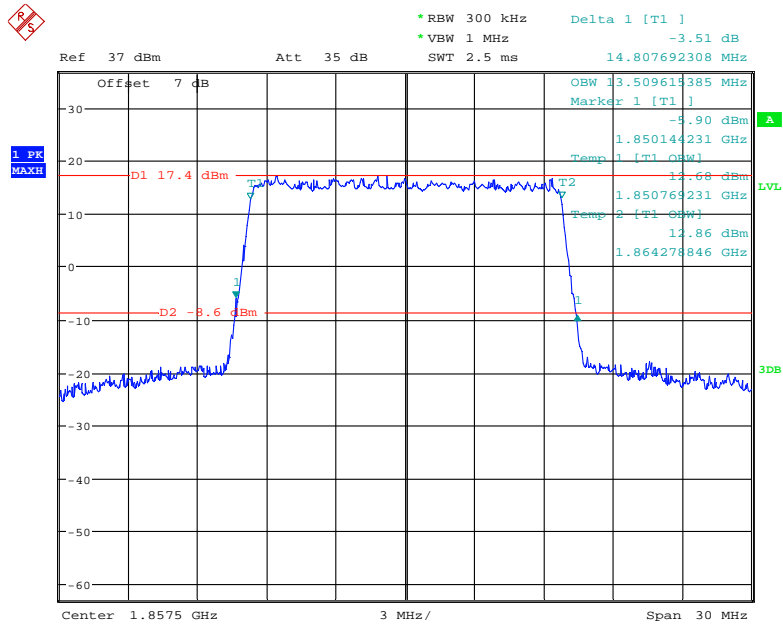

Date: 19.NOV.2020 10:31:14

Band 2_15 MHz_L_QPSK_RB75#0

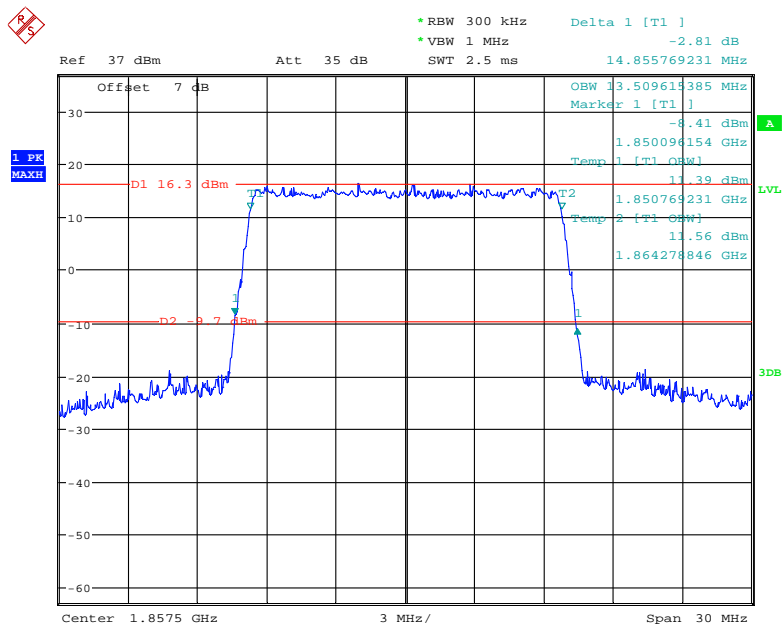

Date: 24.NOV.2020 18:45:25

2_15 MHz_Middle_QPSK_RB75#0

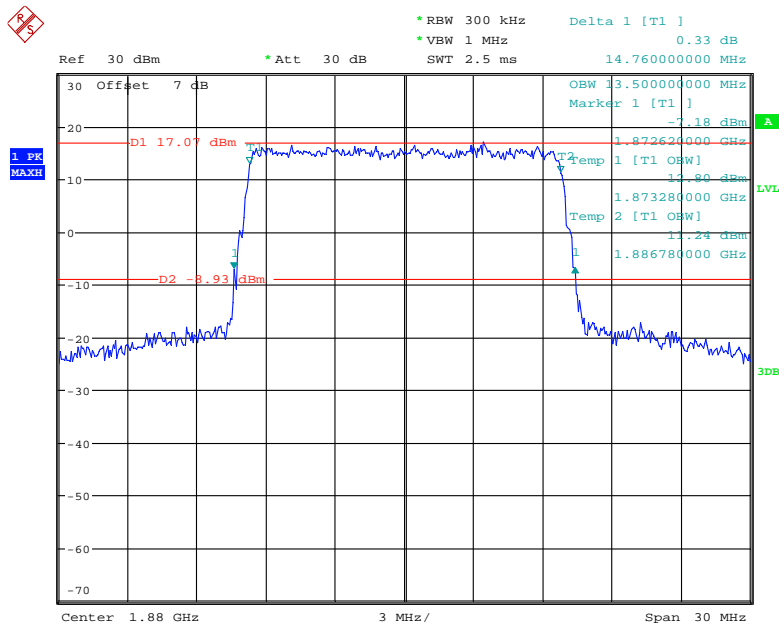

Date: 18.NOV.2020 14:28:49

Band 2_15 MHz_Middle_16QAM_RB75#0

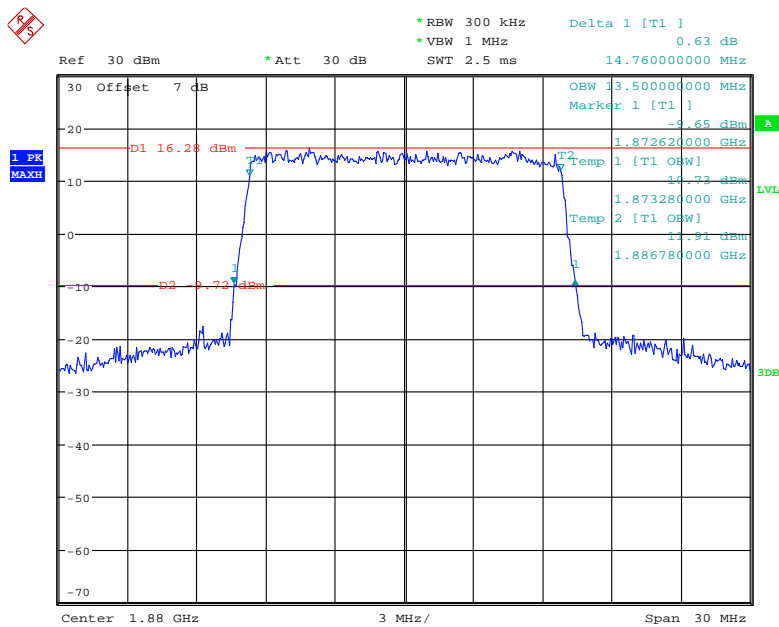

Date: 18.NOV.2020 14:29:14

Band 2_15 MHz_H_16QAM_RB75#0

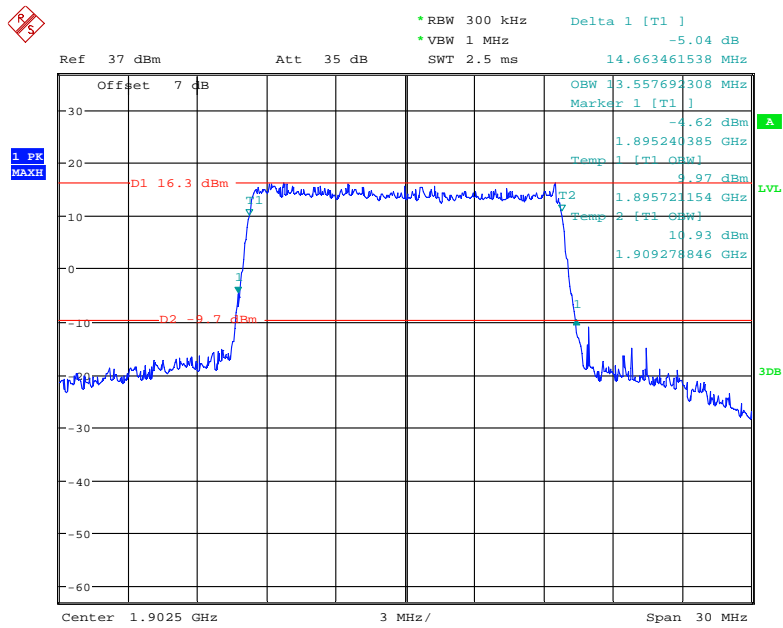

Date: 19.NOV.2020 10:34:01

Band 2_15 MHz_H_QPSK_RB75#0

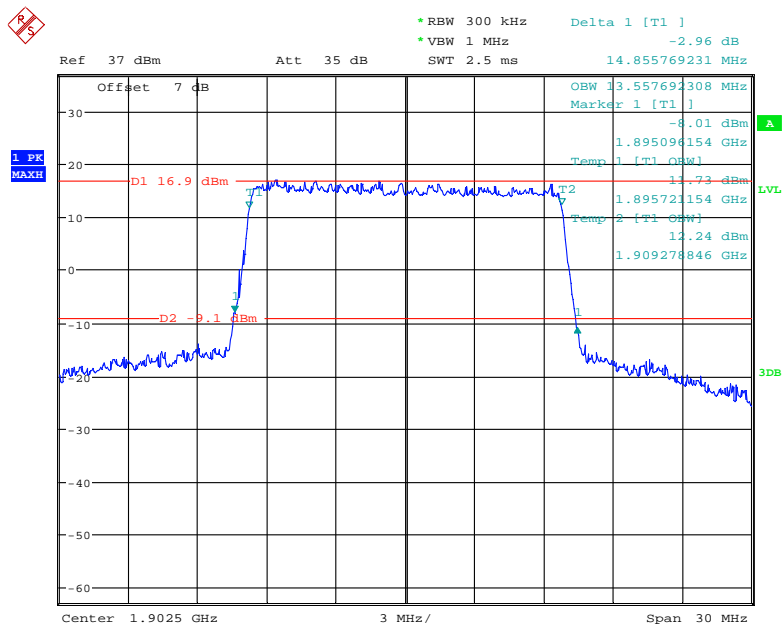

Date: 19.NOV.2020 10:34:43

Band 2_20 MHz_L_16QAM_RB100#0

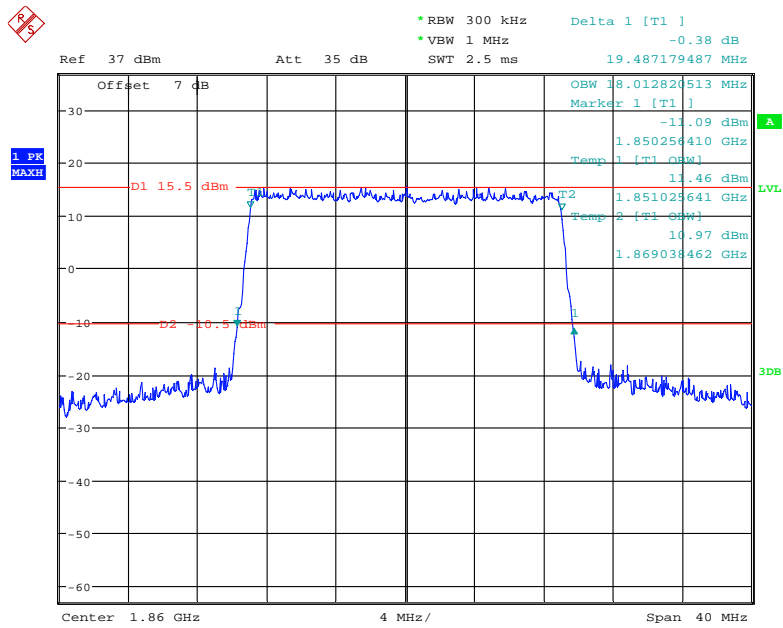

Date: 24.NOV.2020 18:47:48

Band 2_20 MHz_L_QPSK_RB100#0

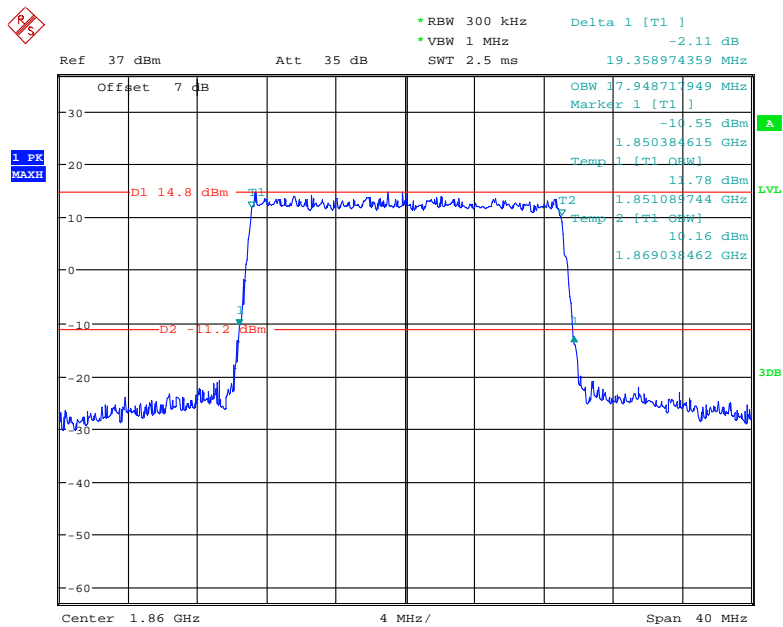

Date: 24.NOV.2020 18:48:36

Band 2_20 MHz_Middle_QPSK_RB100#0

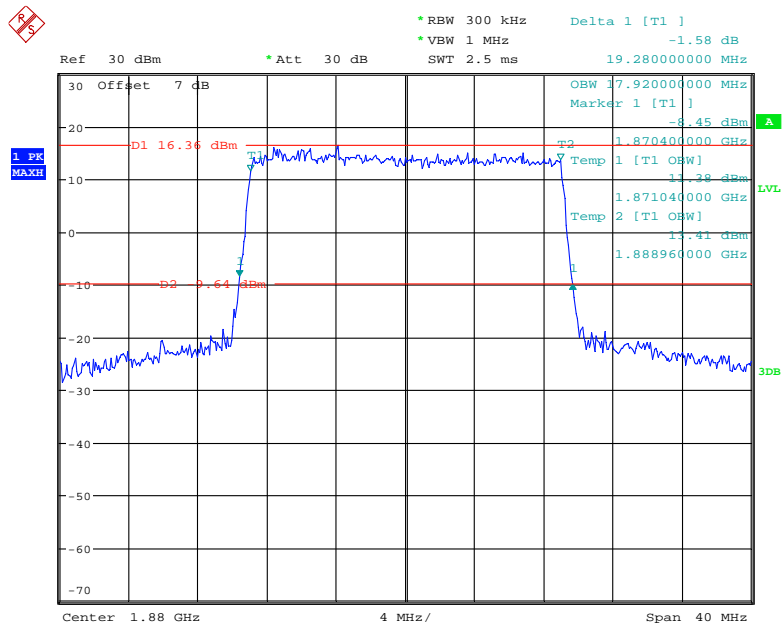

Date: 18.NOV.2020 14:29:41

Band 2_20 MHz_Middle_16QAM_RB100#0

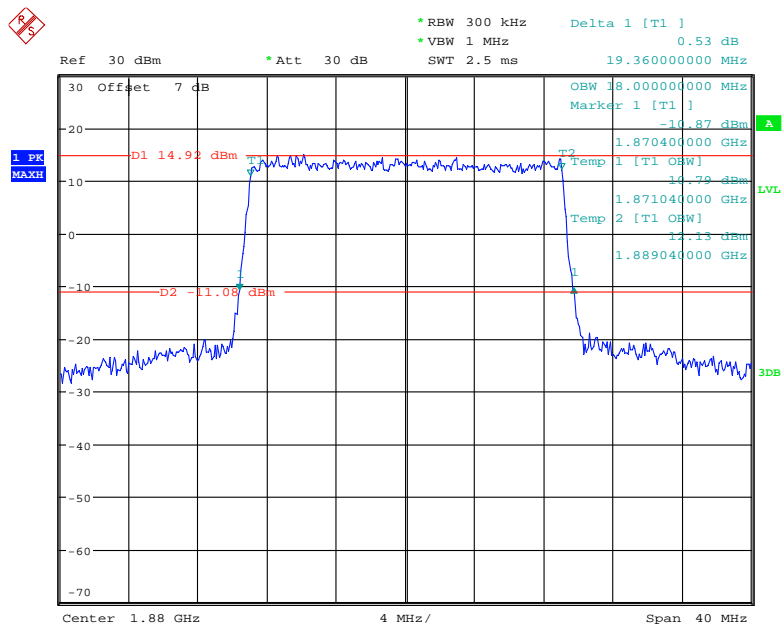

Date: 18.NOV.2020 14:30:06

Band 2_20 MHz_H_16QAM_RB100#0

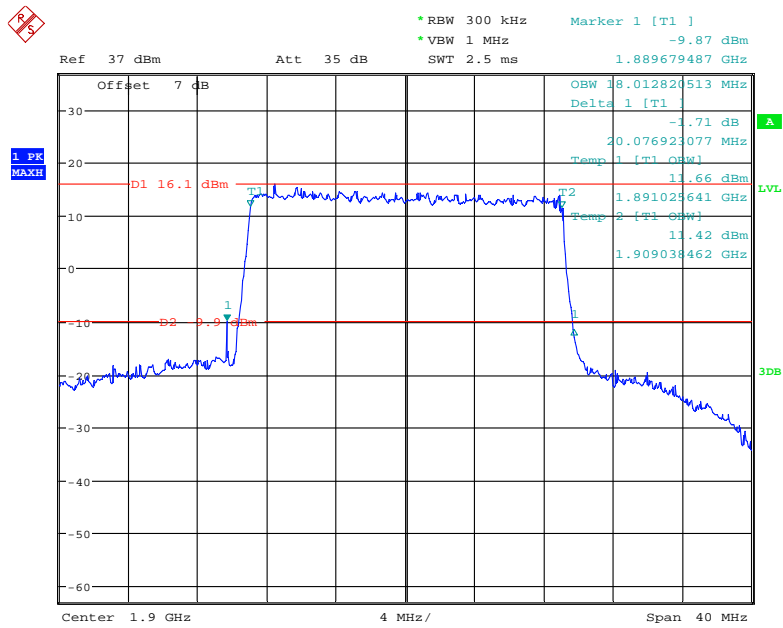

Date: 19.NOV.2020 10:38:22

Band 2_20 MHz_H_QPSK_RB100#0

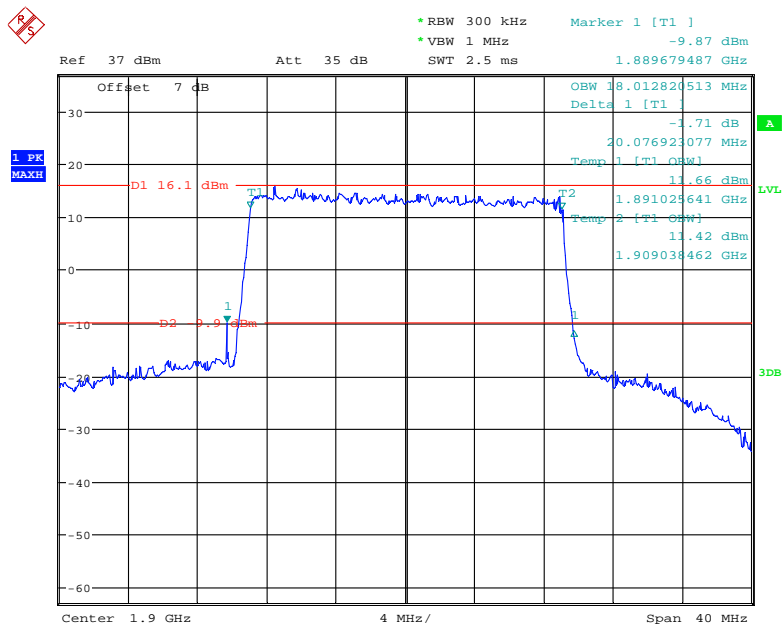

Date: 19.NOV.2020 10:38:22

Band 4:

Bandwidth (MHz)	Modulation	Channel	99% Occupied Bandwidth (MHz)	26 dB Emission Bandwidth (MHz)
1.4	QPSK	Low	1.11	1.30
		Middle	1.10	1.30
		High	1.10	1.30
	16QAM	Low	1.10	1.31
		Middle	1.10	1.30
		High	1.11	1.31
3	QPSK	Low	2.67	2.87
		Middle	2.69	2.87
		High	2.68	2.88
	16QAM	Low	2.69	2.88
		Middle	2.69	2.88
		High	2.68	2.86
5	QPSK	Low	4.50	4.95
		Middle	4.52	4.90
		High	4.50	4.89
	16QAM	Low	4.50	4.94
		Middle	4.50	4.95
		High	4.52	4.93
10	QPSK	Low	8.97	9.58
		Middle	8.96	9.64
		High	8.97	9.58
	16QAM	Low	8.97	9.58
		Middle	8.96	9.52
		High	8.97	9.58
15	QPSK	Low	13.51	14.75
		Middle	13.50	15.00
		High	13.51	14.72
	16QAM	Low	13.51	14.71
		Middle	13.56	14.70
		High	13.51	14.72
20	QPSK	Low	18.01	19.42
		Middle	18.00	19.28
		High	17.94	19.32
	16QAM	Low	17.95	19.42
		Middle	17.92	19.28
		High	17.95	19.42

Band 4_1.4 MHz_Low_16QAM_RB6#0

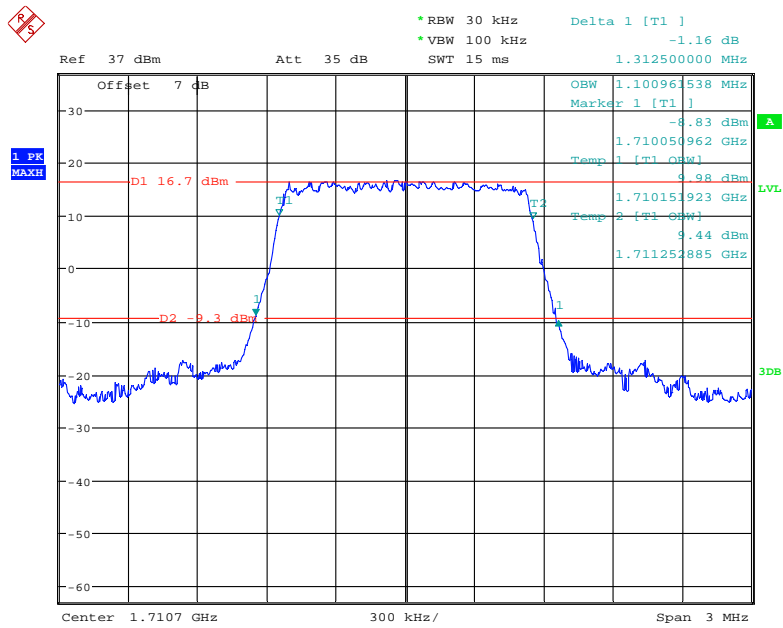

Date: 19.NOV.2020 10:40:36

Band 4_1.4 MHz_Low_QPSK_RB6#0

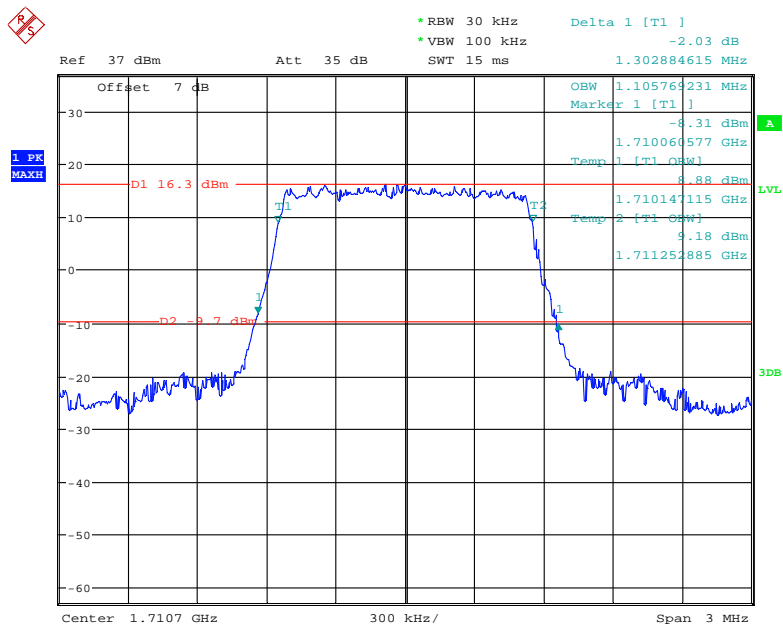

Date: 24.NOV.2020 18:51:22

Band 4_1.4 MHz_Middle_QPSK_RB6#0

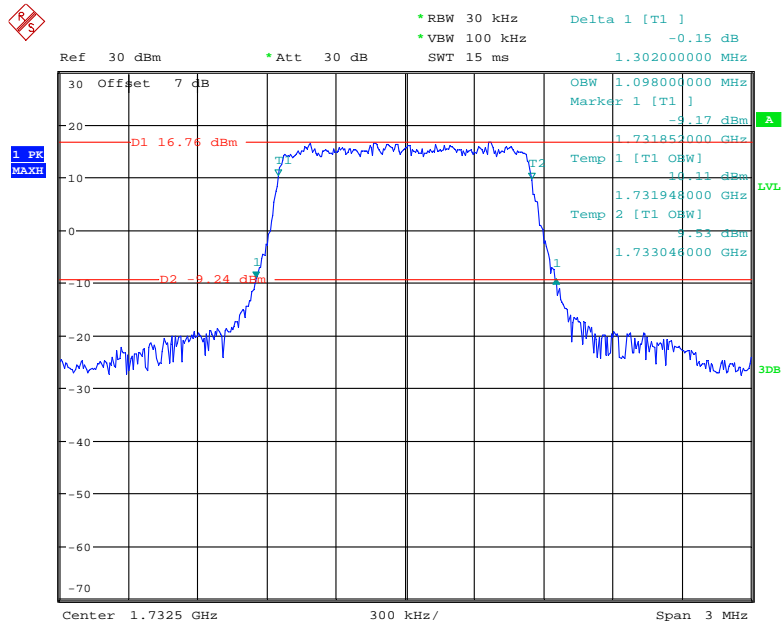

Date: 18.NOV.2020 14:30:29

Band 4_1.4 MHz_Middle_16QAM_RB6#0

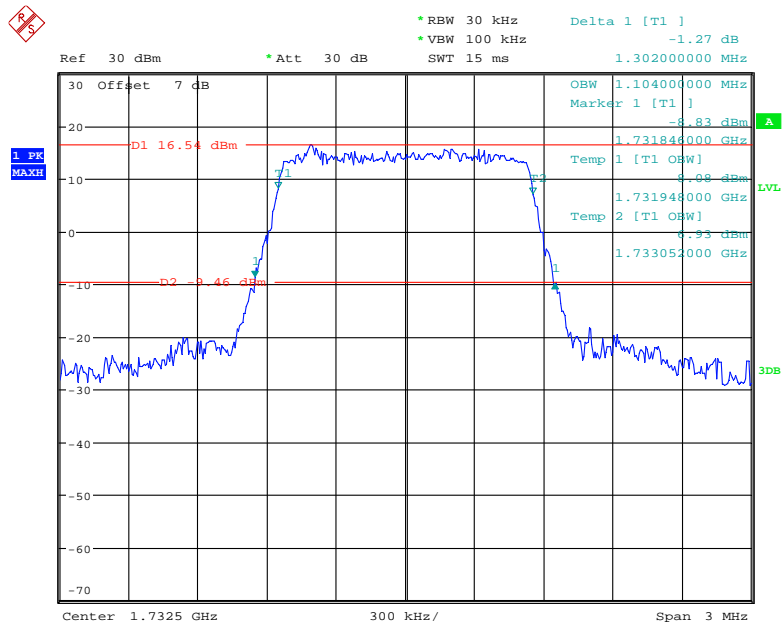

Date: 18.NOV.2020 14:30:47

Band 4_1.4 MHz_H_16QAM_RB6#0

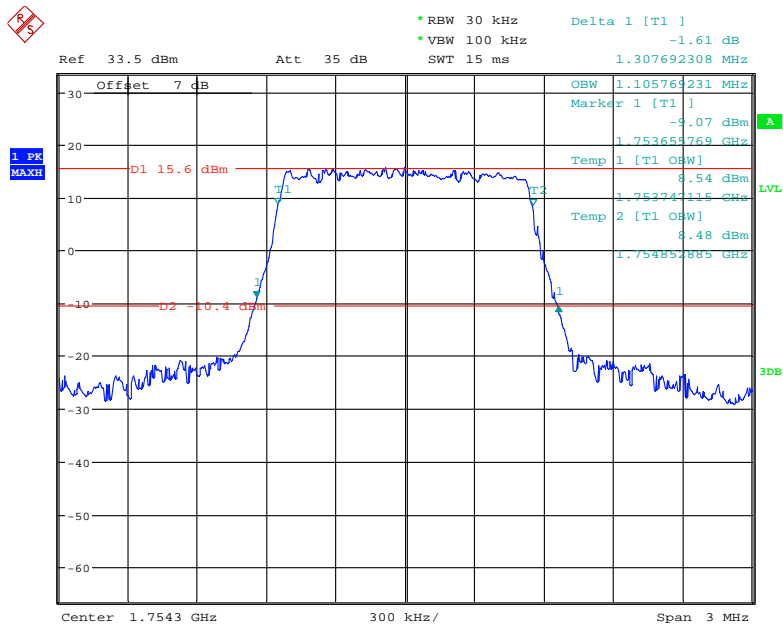

Date: 26.NOV.2020 13:36:49

Band 4_1.4 MHz_H_QPSK_RB6#0

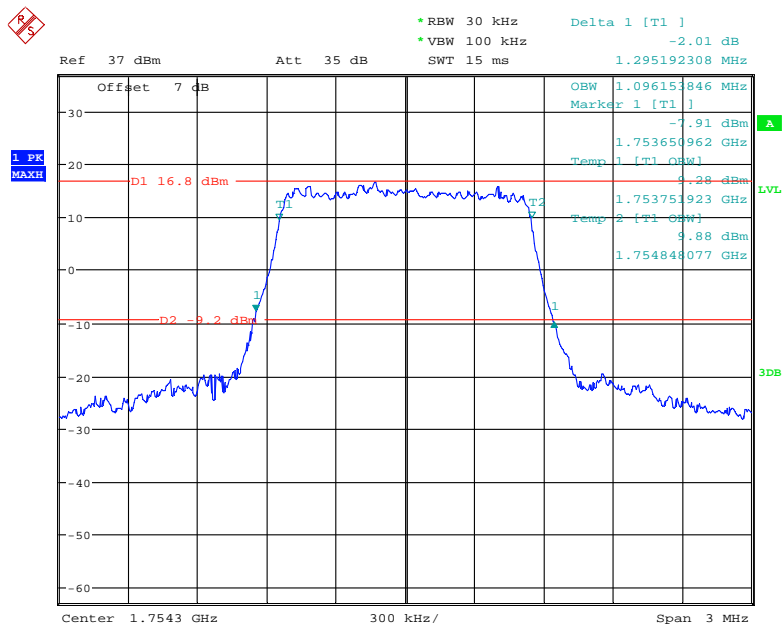

Date: 19.NOV.2020 10:42:21

Band 4_3 MHz_L_16QAM_RB15#0

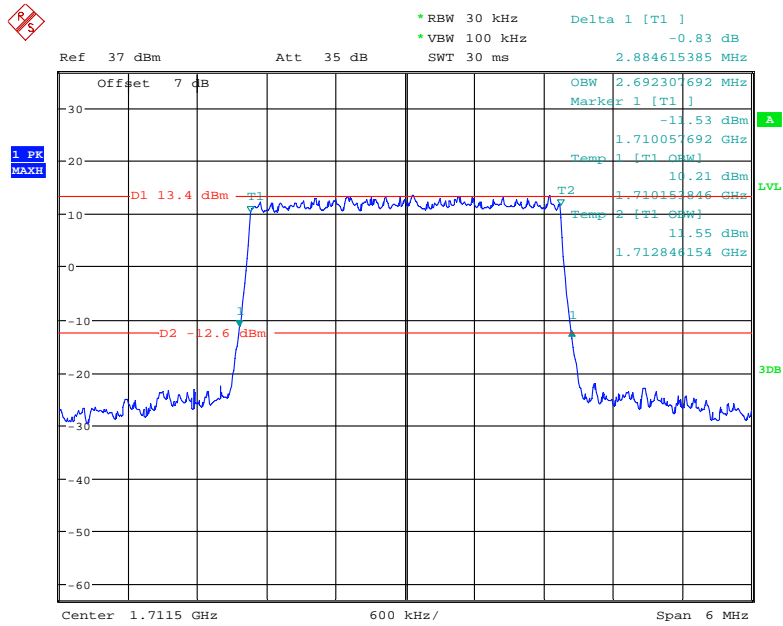

Date: 19.NOV.2020 10:44:06

Band 4_3 MHz_L_QPSK_RB15#0

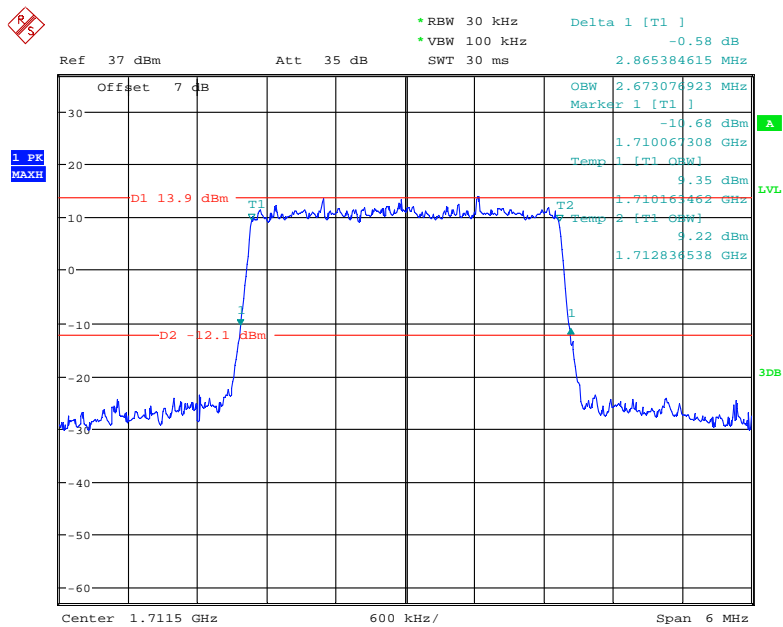

Date: 19.NOV.2020 10:45:01

Band 4_3 MHz_Middle_16QAM_RB15#0

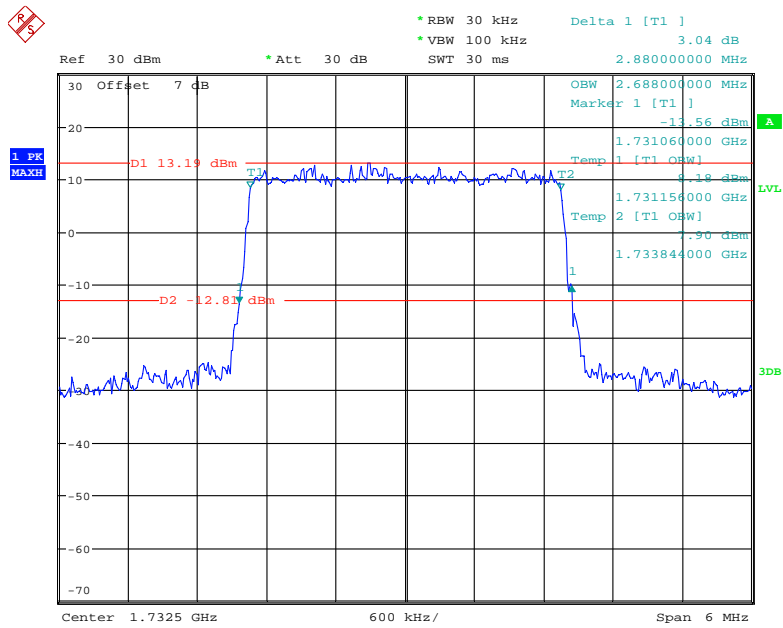

Date: 18.NOV.2020 14:31:24

Band 4_3 MHz_Middle_QPSK_RB15#0

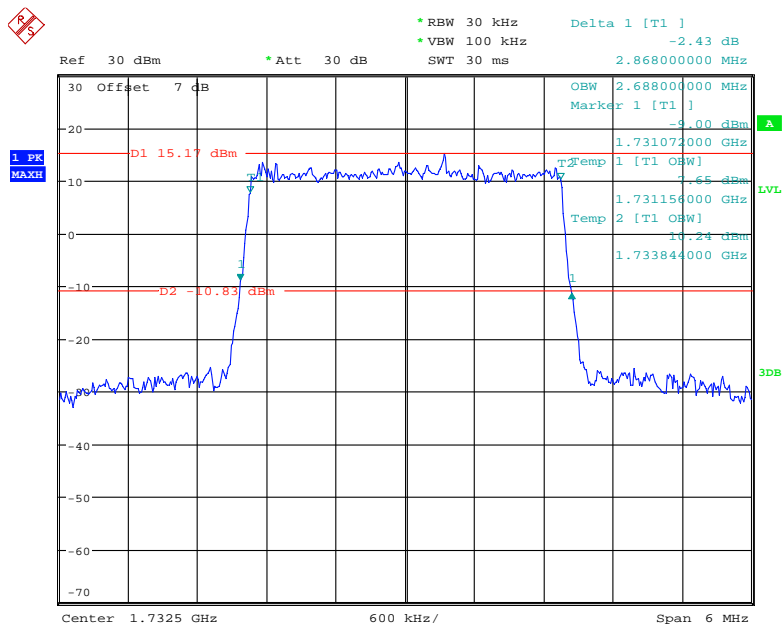

Date: 18.NOV.2020 14:31:06

Band 4_3 MHz_H_16QAM_RB15#0

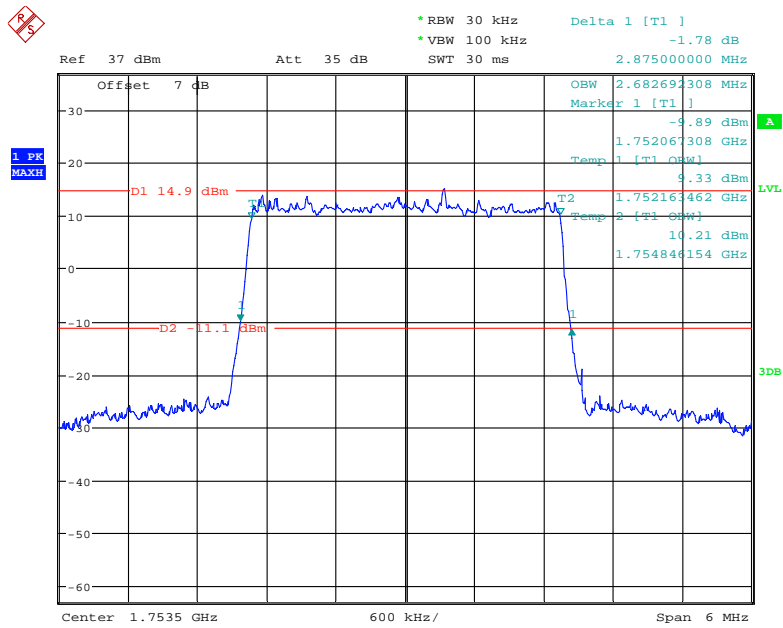

Date: 19.NOV.2020 10:46:56

Band 4_3 MHz_H_QPSK_RB15#0

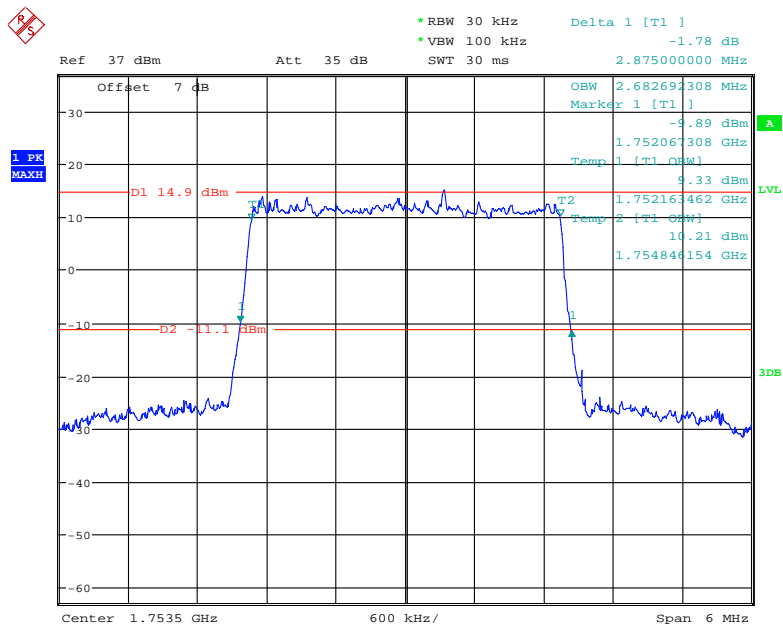

Date: 19.NOV.2020 10:46:56

Band 4_5 MHz_H_16QAM_RB25#0

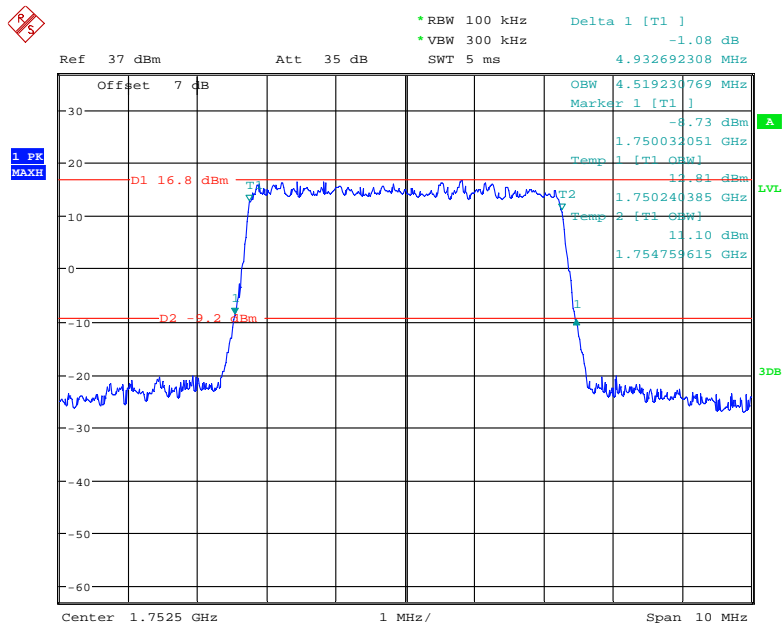

Date: 19.NOV.2020 10:51:23

Band 4_5 MHz_H_QPSK_RB25#0

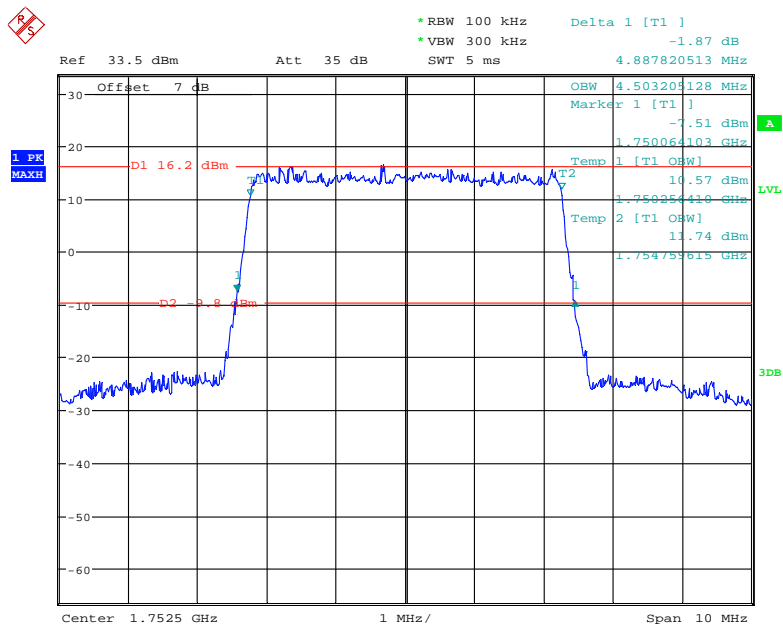

Date: 26.NOV.2020 08:45:20

Band 4_5 MHz_L_16QAM_RB25#0

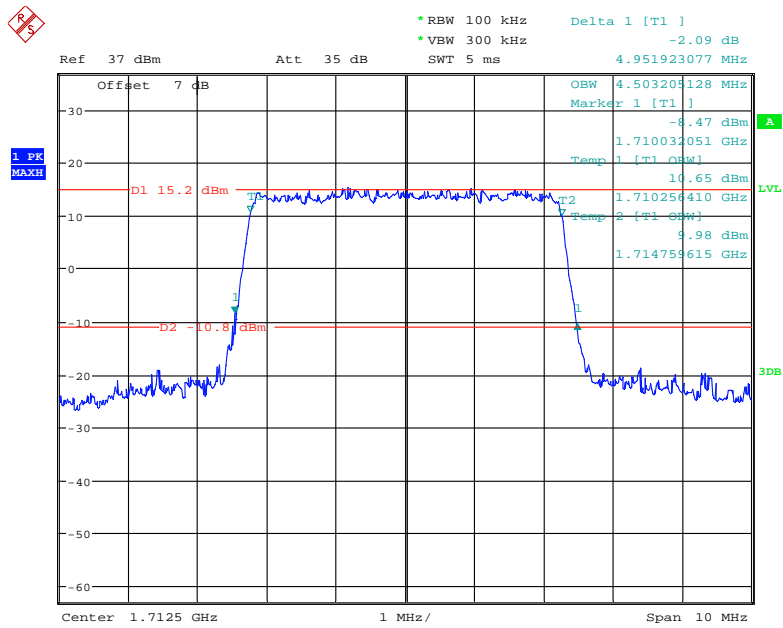

Date: 19.NOV.2020 10:48:59

Band 4_5 MHz_L_QPSK_RB25#0

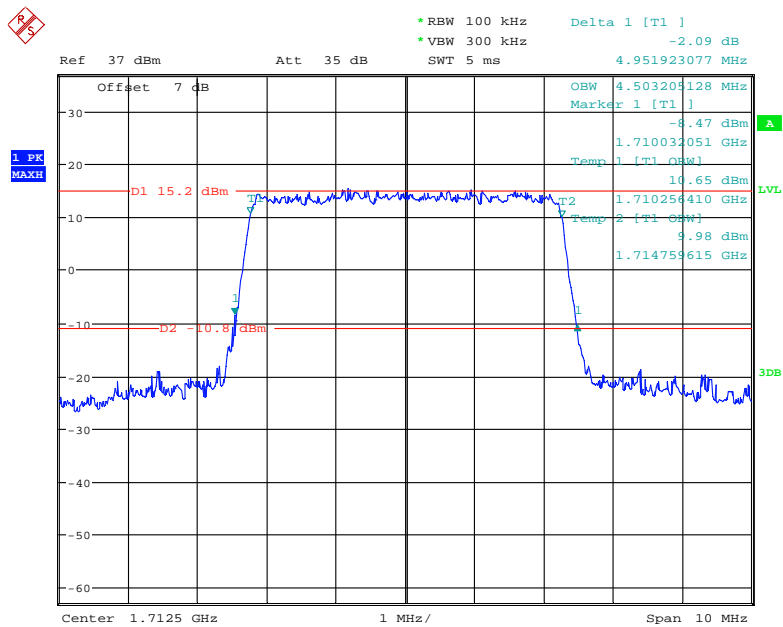

Date: 19.NOV.2020 10:48:59

Band 4_5 MHz_Middle_QPSK_RB25#0

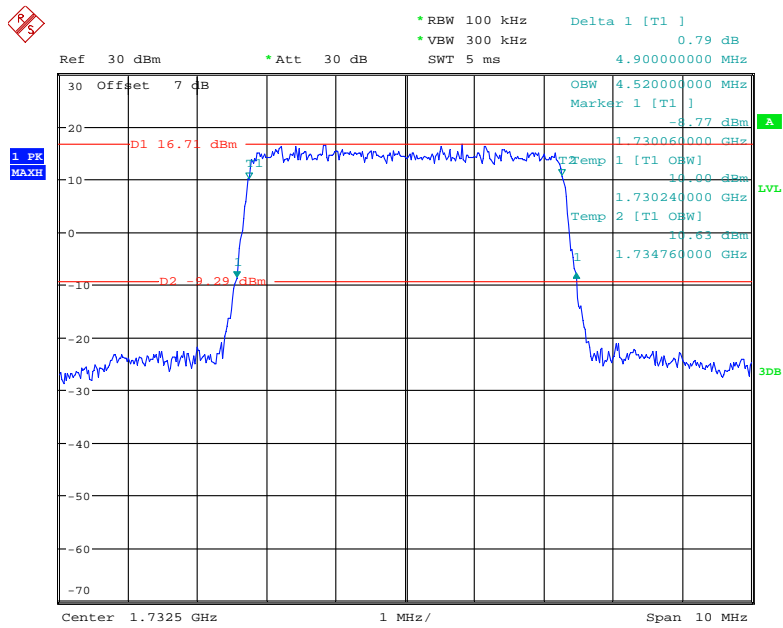

Date: 18.NOV.2020 14:31:48

Band 4_5 MHz_Middle_16QAM_RB25#0

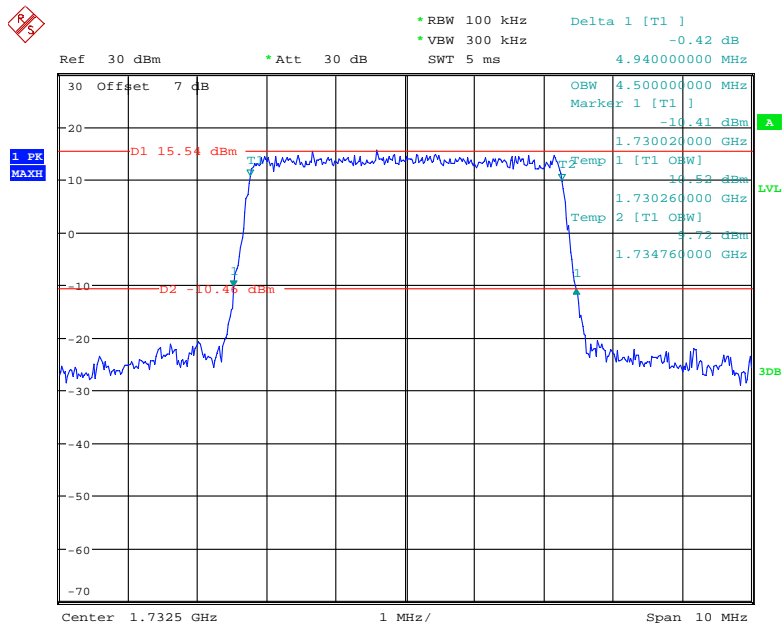

Date: 18.NOV.2020 14:32:09

Band 4_10 MHz_L_16QAM_RB50#0

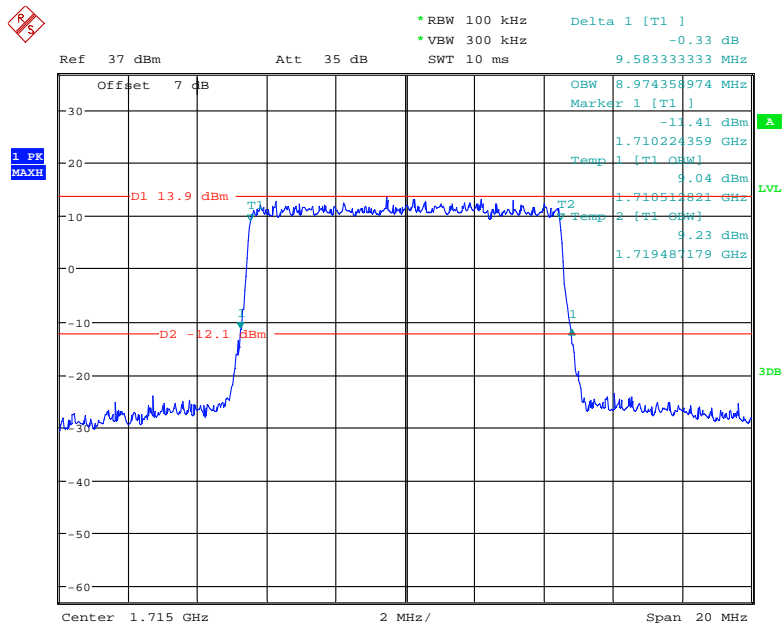

Date: 19.NOV.2020 10:53:19

Band 4_10 MHz_L_QPSK_RB50#0

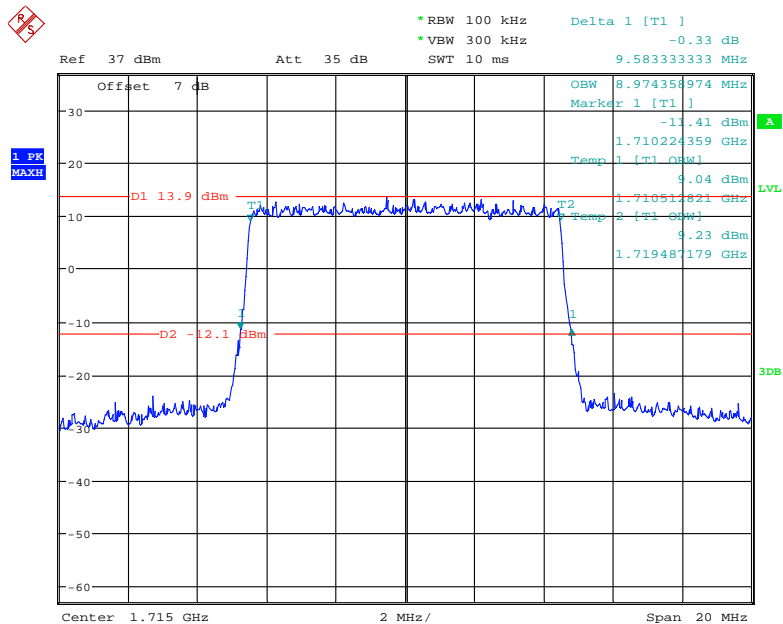

Date: 19.NOV.2020 10:53:19

Band 4_10 MHz_Middle_QPSK_RB50#0

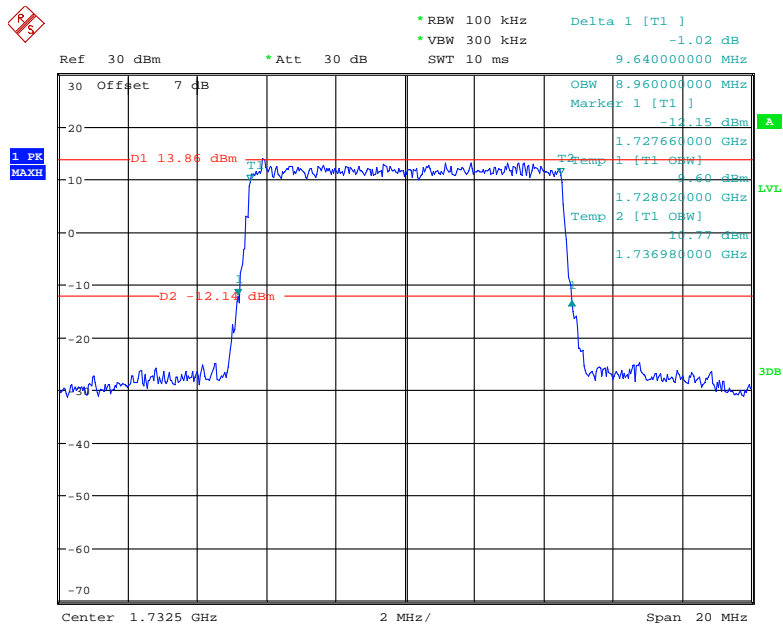

Date: 18.NOV.2020 14:32:34

Band 4_10 MHz_Middle_16QAM_RB50#0

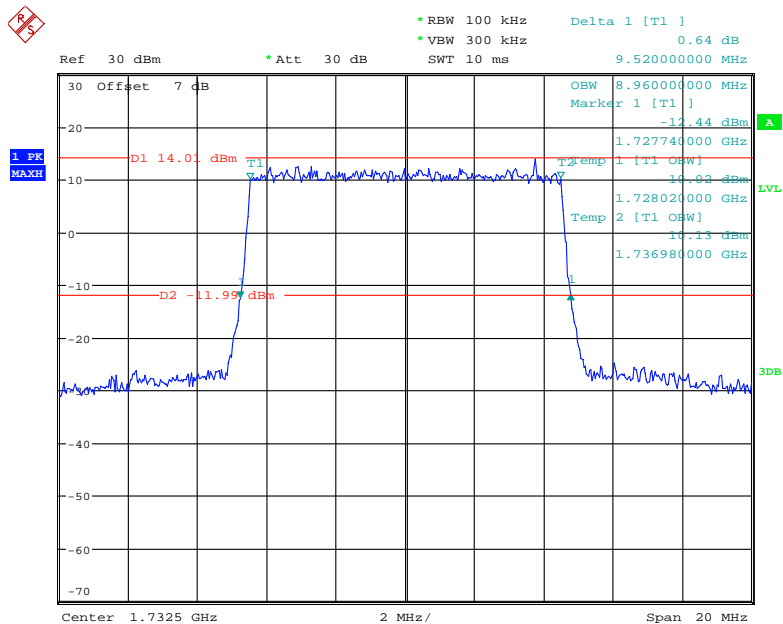

Date: 18.NOV.2020 14:32:55

Band 4_10 MHz_H_16QAM_RB50#0

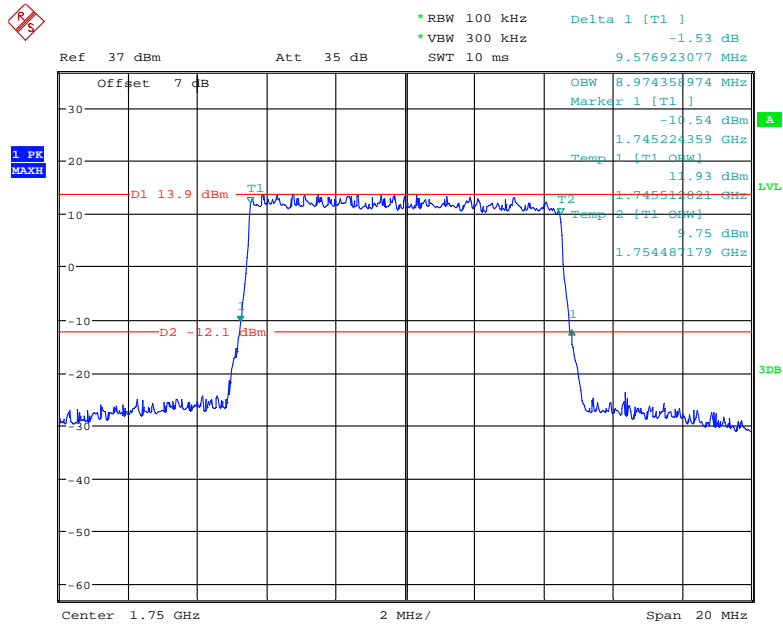

Date: 19.NOV.2020 10:56:05

Band 4_10 MHz_H_QPSK_RB50#0

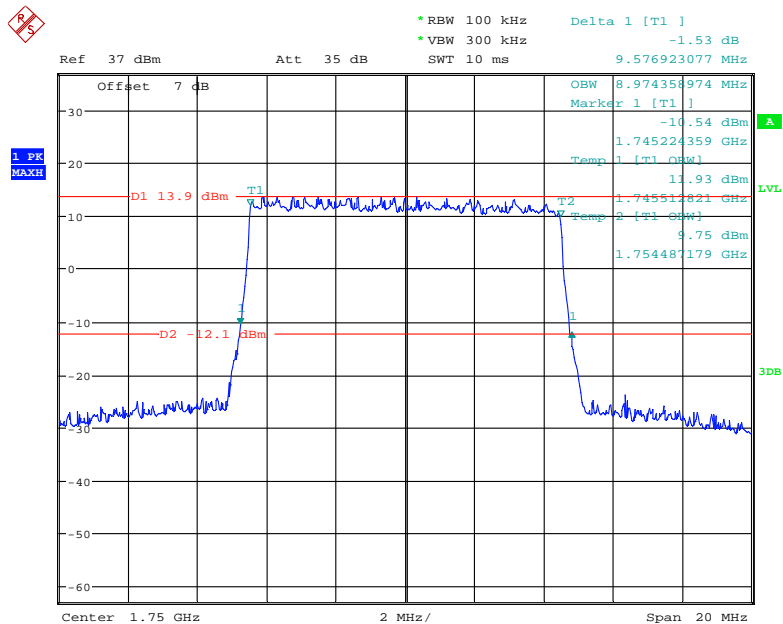

Date: 19.NOV.2020 10:56:05

Band 4_15 MHz_L_16QAM_RB75#0

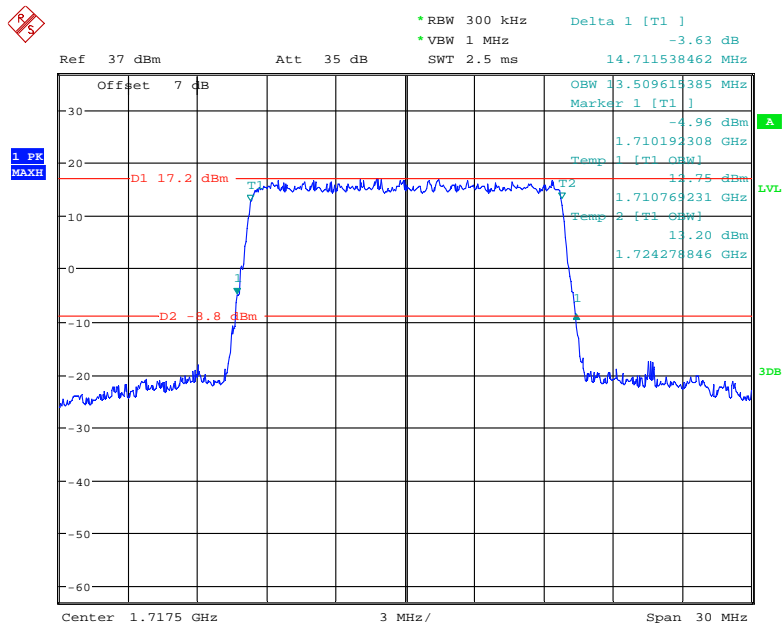

Date: 19.NOV.2020 10:58:00

Band 4_15 MHz_L_QPSK_RB75#0

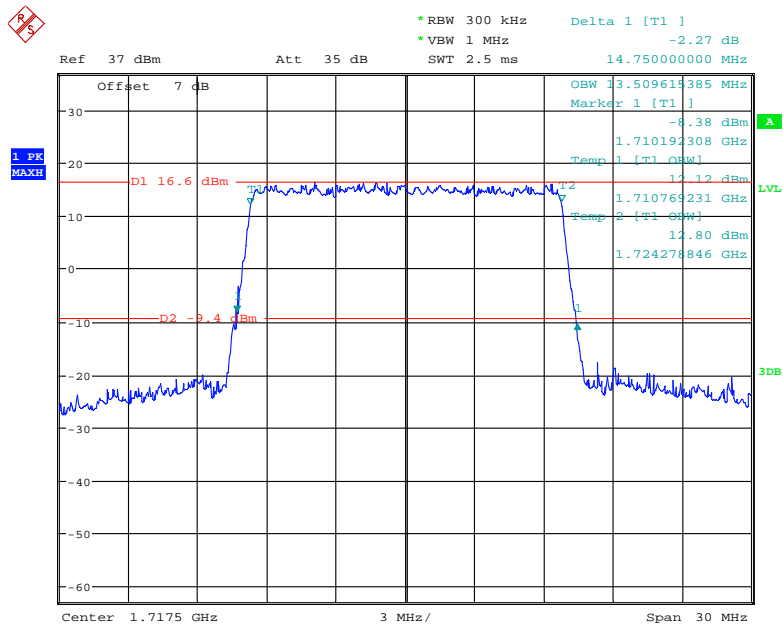

Date: 24.NOV.2020 18:53:33

Band 4_15 MHz_Middle_QPSK_RB75#0

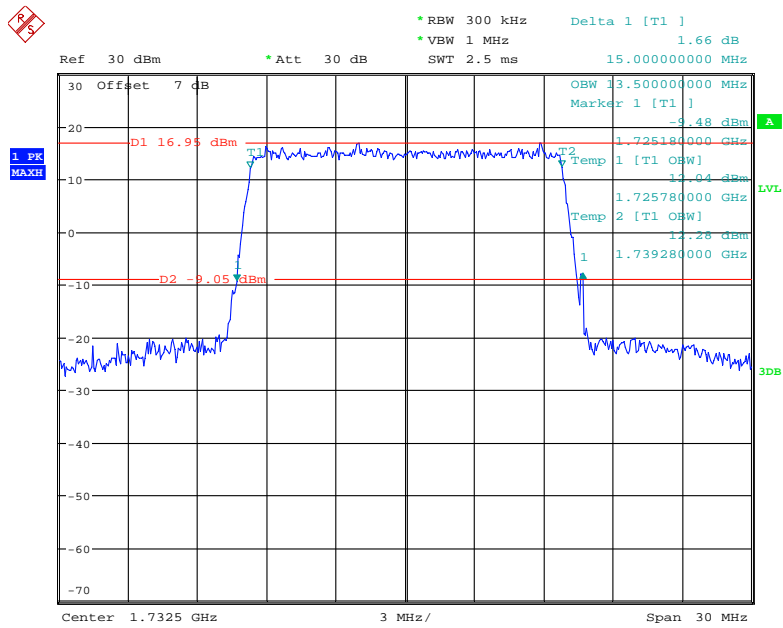

Date: 18.NOV.2020 14:33:22

Band 4_15 MHz_Middle_16QAM_RB75#0

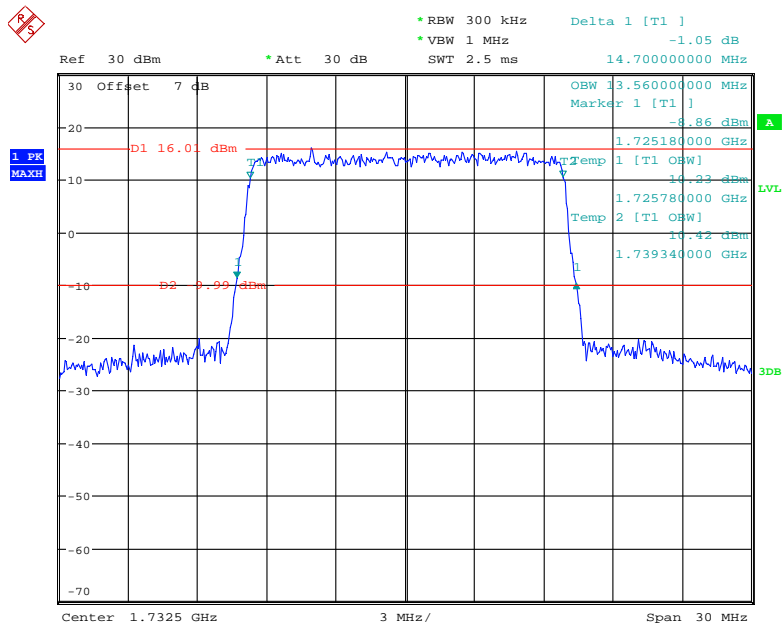

Date: 18.NOV.2020 14:33:44

Band 4_15 MHz_H_16QAM_RB75#0

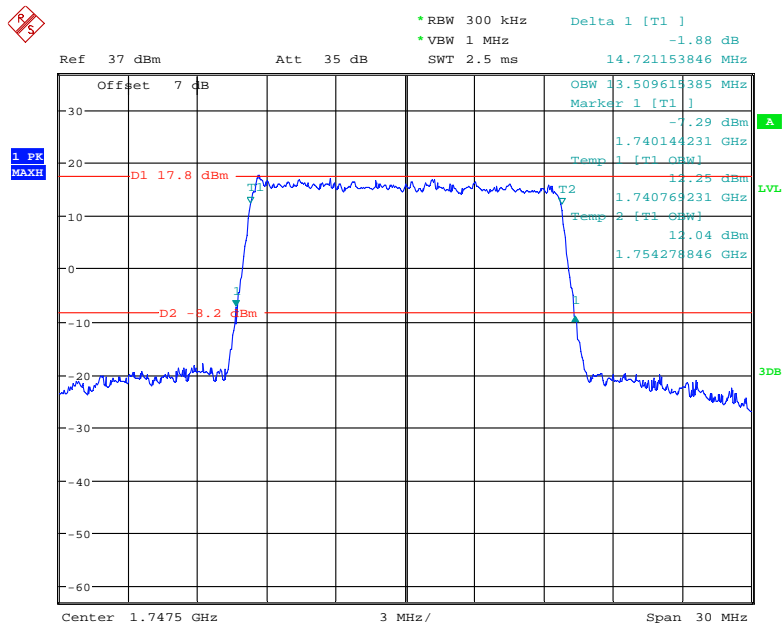

Date: 19.NOV.2020 11:01:03

Band 4_15 MHz_H_QPSK_RB75#0

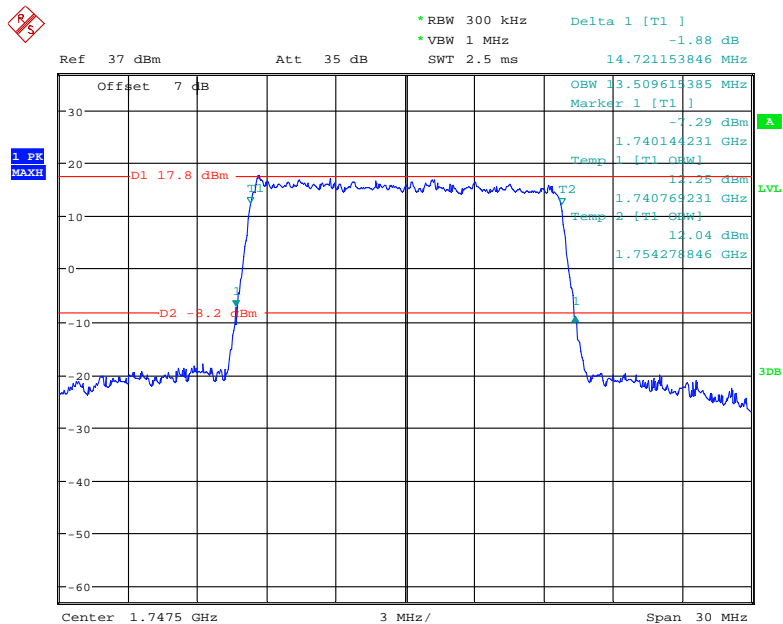

Date: 19.NOV.2020 11:01:03

Band 4_20 MHz_L_16QAM_RB100#0

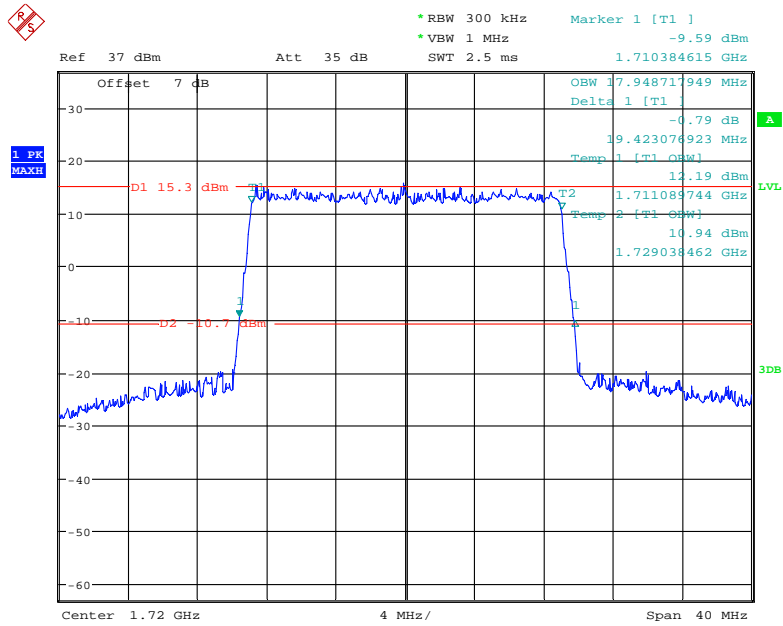

Date: 19.NOV.2020 11:03:52

Band 4_20 MHz_L_QPSK_RB100#0

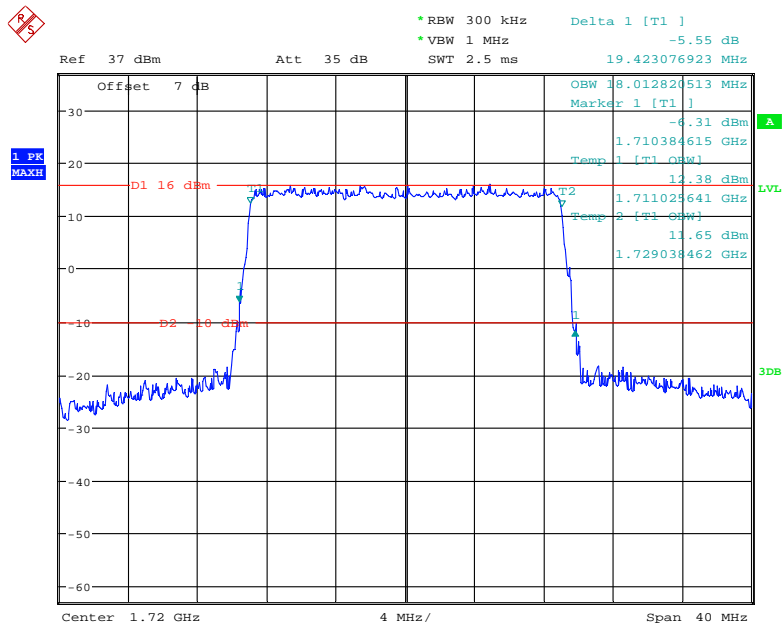

Date: 19.NOV.2020 11:03:09

Band 4_20 MHz_Middle_QPSK_RB100#0

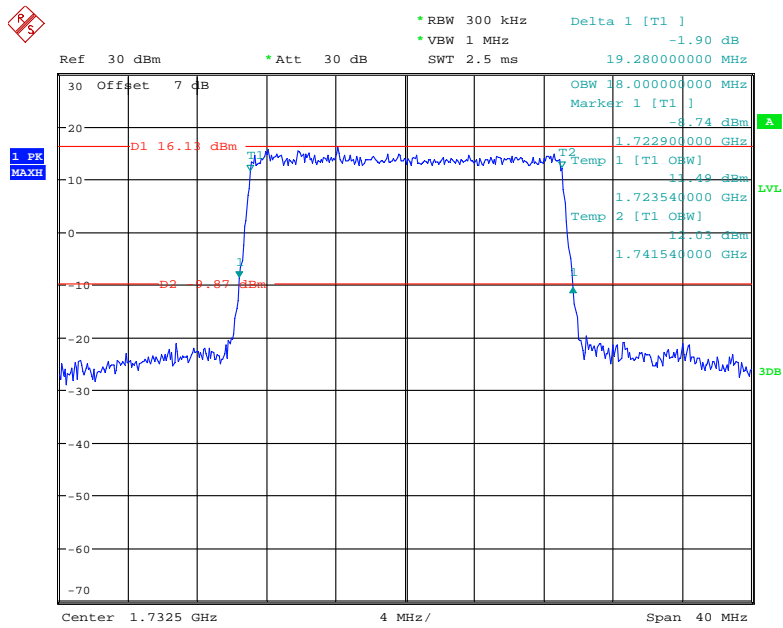

Date: 18.NOV.2020 14:34:15

Band 4_20 MHz_Middle_16QAM_RB100#0

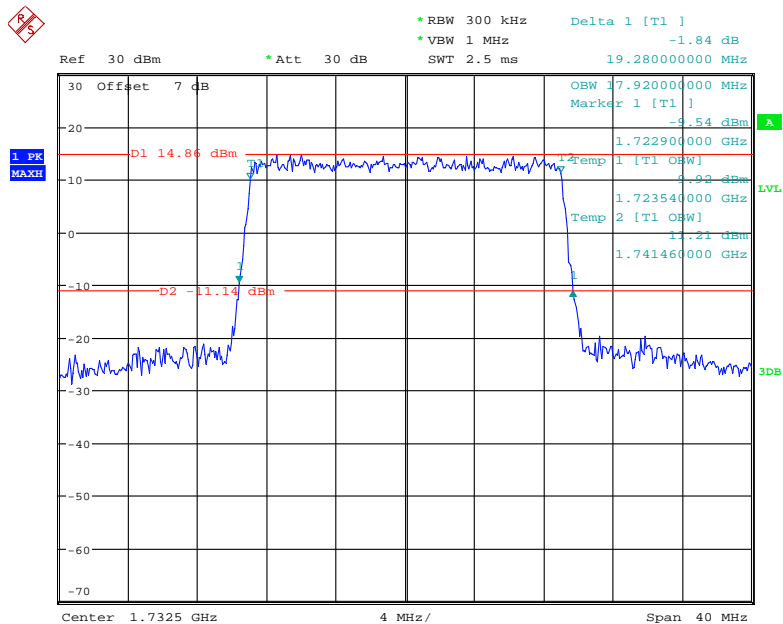

Date: 18.NOV.2020 14:34:40

Band 4_20 MHz_H_16QAM_RB100#0

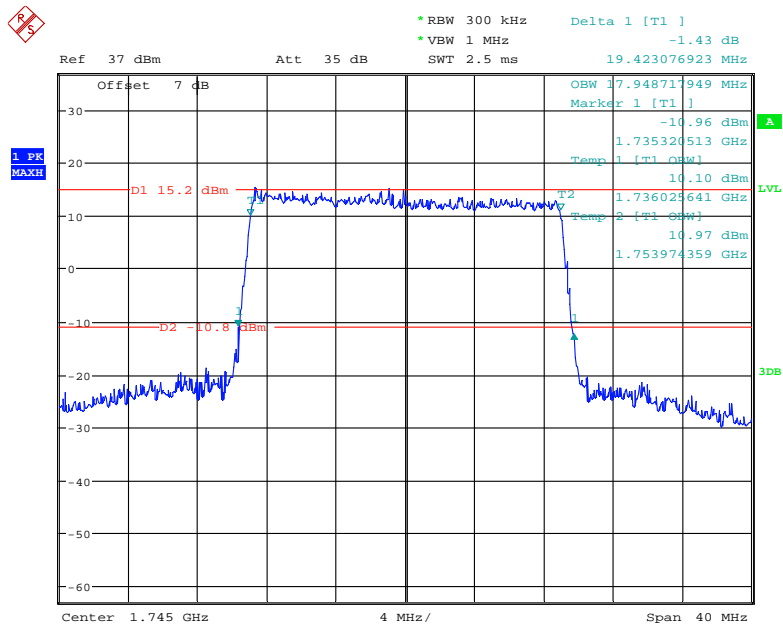

Date: 24.NOV.2020 18:55:35

Band 4_20 MHz_H_QPSK_RB100#0

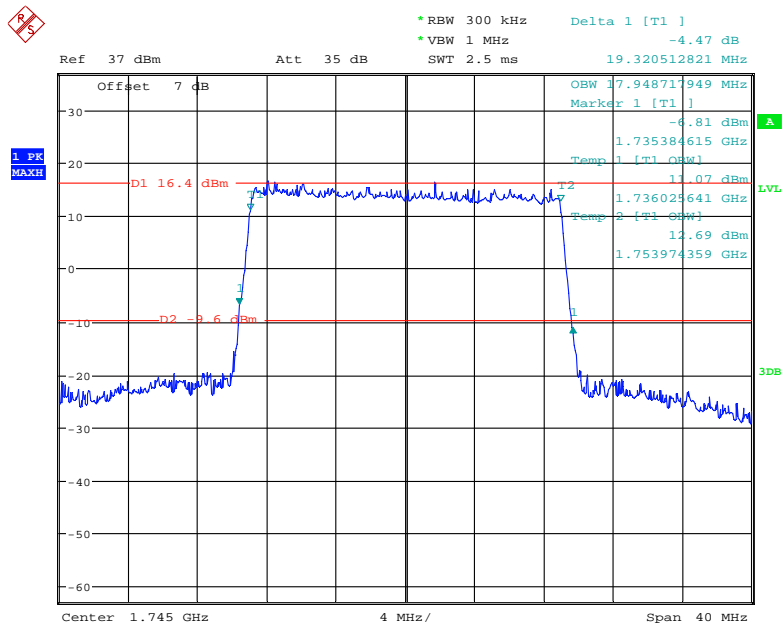

Date: 19.NOV.2020 11:06:09

Band 5:

Bandwidth (MHz)	Modulation	Channel	99% Occupied Bandwidth (MHz)	26 dB Emission Bandwidth (MHz)
1.4	QPSK	Low	1.10	1.49
		Middle	1.10	1.30
		High	1.10	1.31
	16QAM	Low	1.10	1.29
		Middle	1.10	1.31
		High	1.10	1.31
3	QPSK	Low	2.68	2.89
		Middle	2.69	2.87
		High	2.69	2.89
	16QAM	Low	2.68	2.89
		Middle	2.69	2.89
		High	2.68	2.87
5	QPSK	Low	4.50	5.03
		Middle	4.52	4.98
		High	4.50	4.93
	16QAM	Low	4.50	4.95
		Middle	4.50	4.90
		High	4.50	4.93
10	QPSK	Low	8.97	9.62
		Middle	9.00	9.64
		High	8.97	9.72
	16QAM	Low	8.97	9.52
		Middle	8.96	9.52
		High	8.42	9.56

Band 5_1.4 MHz_L_QPSK_RB6#0

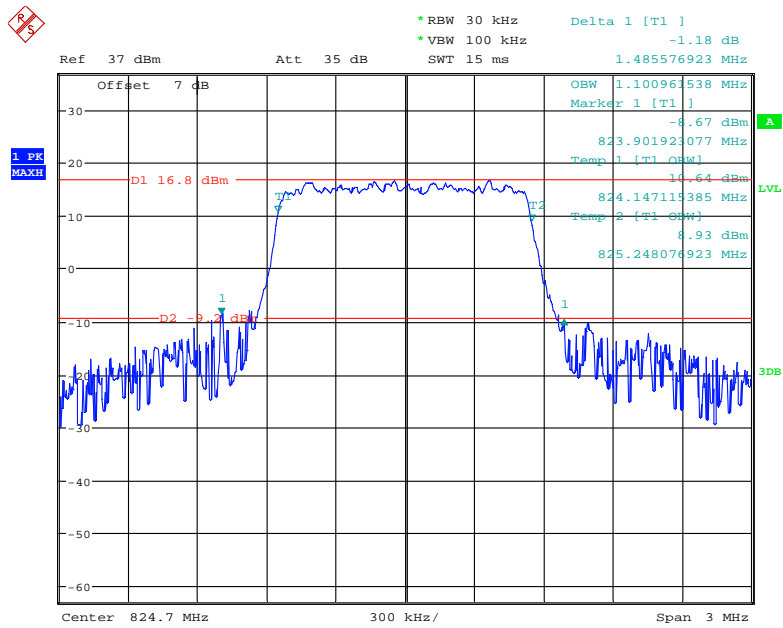

Date: 24.NOV.2020 18:58:18

Band 5_1.4 MHz_L_16QAM_RB6#0

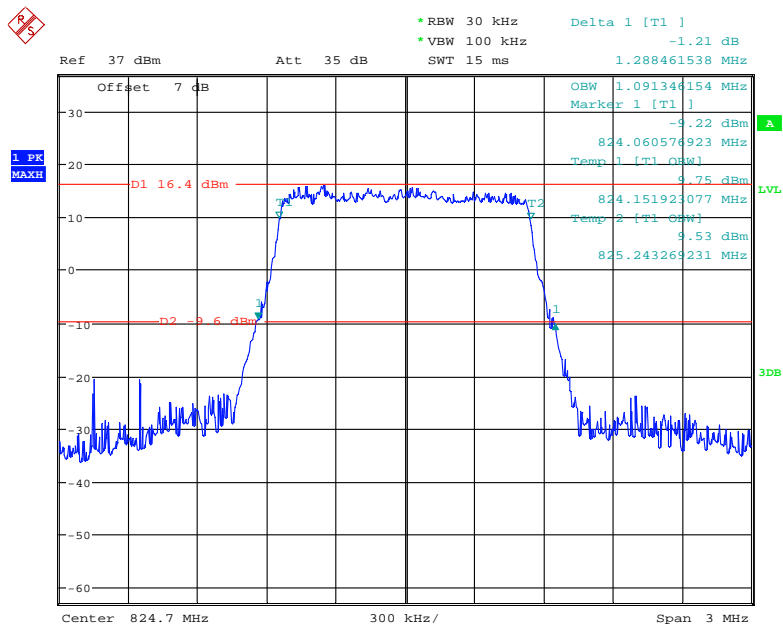

Date: 19.NOV.2020 11:10:40

Band 5_1.4 MHz_Middle_QPSK_RB6#0

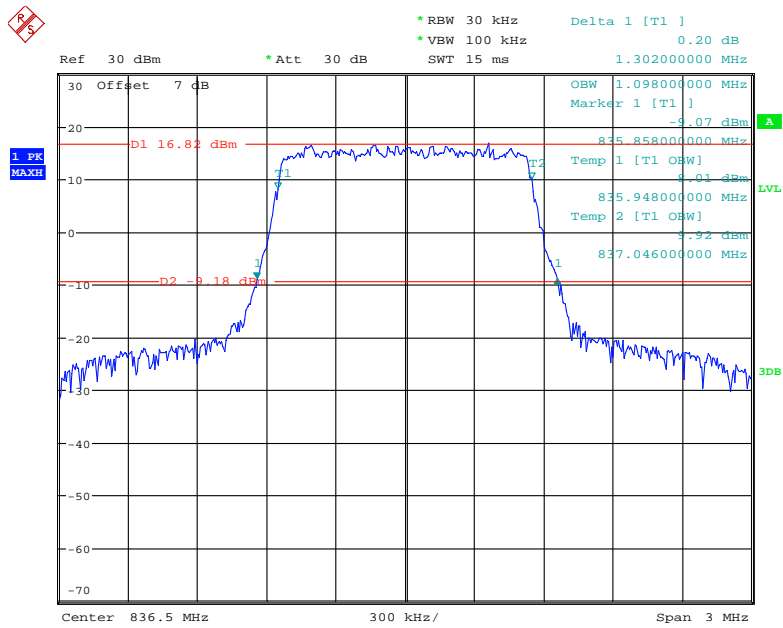

Date: 18.NOV.2020 14:35:06

Band 5_1.4 MHz_Middle_16QAM_RB6#0

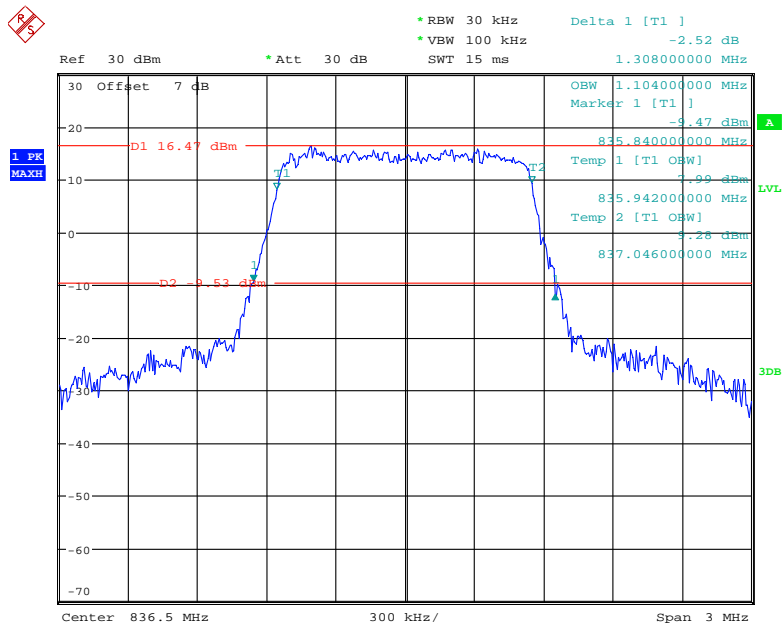

Date: 18.NOV.2020 14:35:30

Band 5_1.4 MHz_H_16QAM_RB6#0

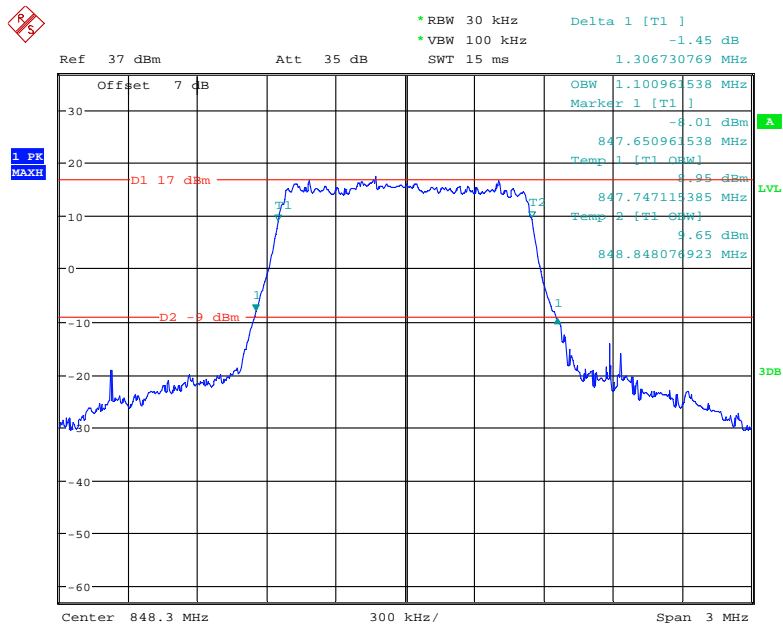

Date: 19.NOV.2020 11:11:55

Band 5_1.4 MHz_H_QPSK_RB6#0

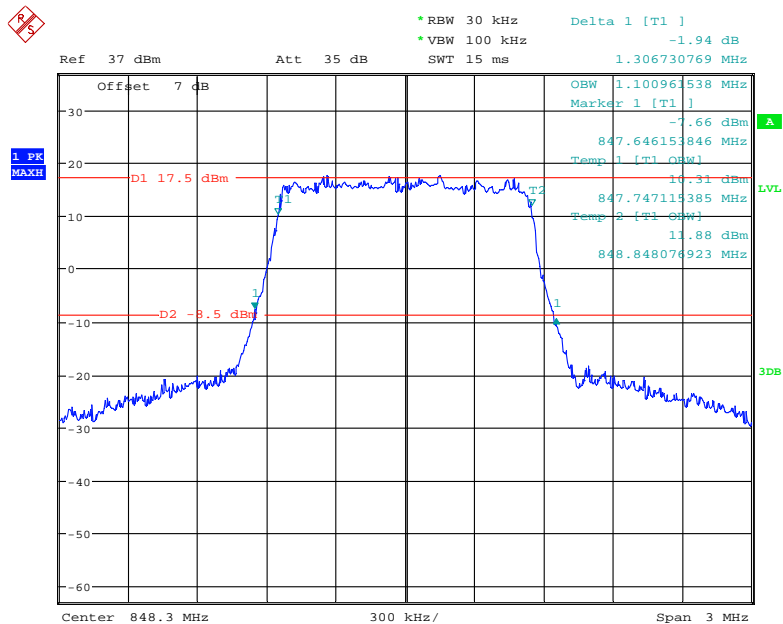

Date: 19.NOV.2020 11:12:58

Band 5_3 MHz_L_16QAM_RB15#0

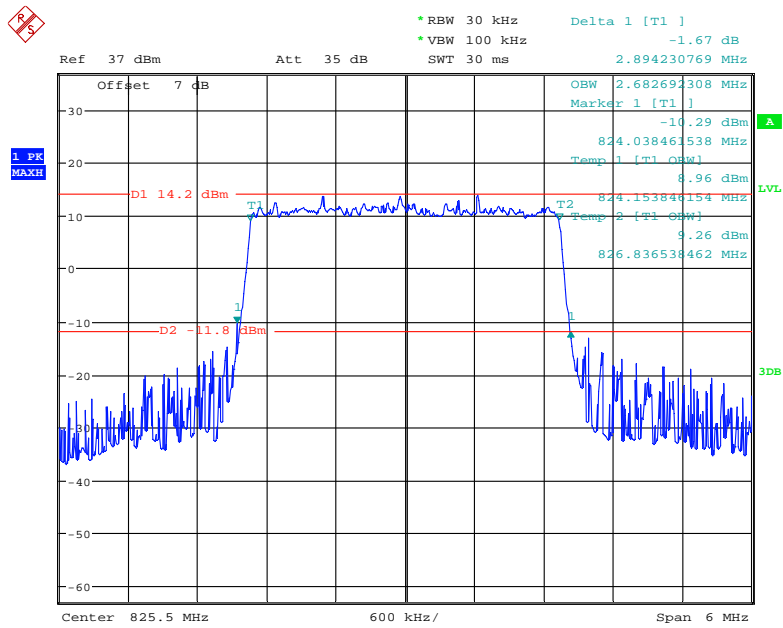

Date: 19.NOV.2020 11:14:41

Band 5_3 MHz_L_QPSK_RB15#0

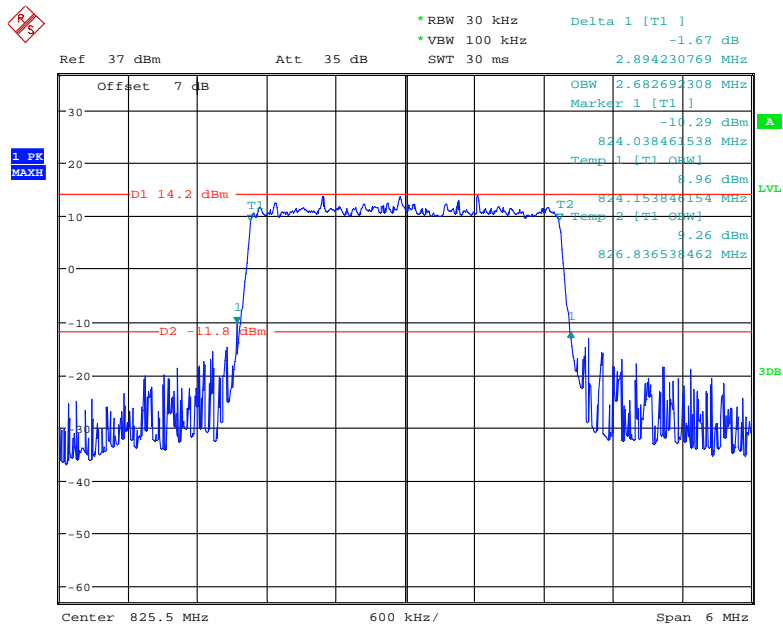

Date: 19.NOV.2020 11:14:41

Band 5_3 MHz_Middle_16QAM_RB15#0

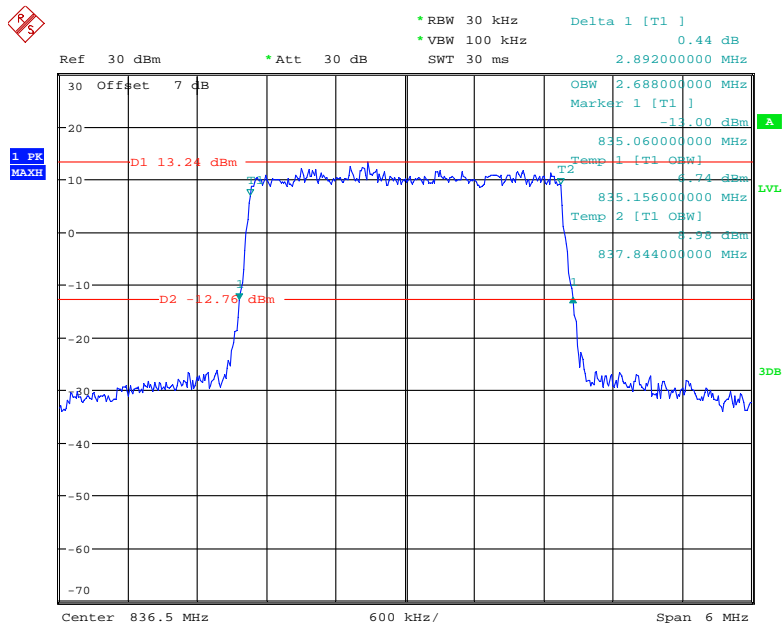

Date: 18.NOV.2020 14:36:13

Band 5_3 MHz_Middle_QPSK_RB15#0

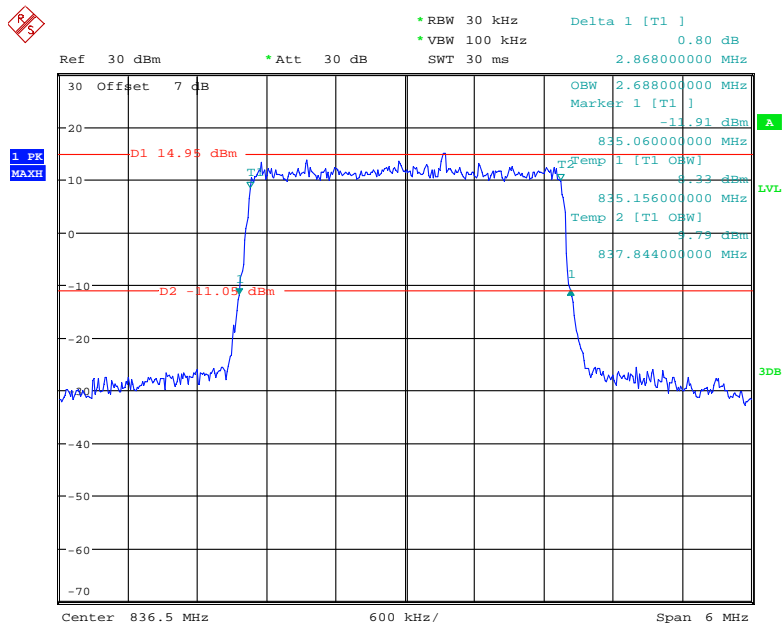

Date: 18.NOV.2020 14:35:52

Band 5_3 MHz_H_16QAM_RB15#0

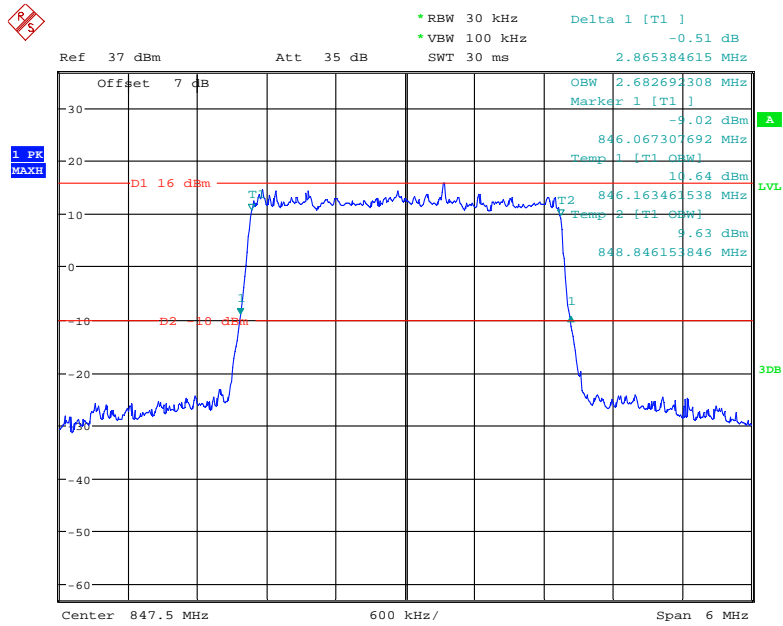

Date: 19.NOV.2020 11:16:56

Band 5_3 MHz_H_QPSK_RB15#0

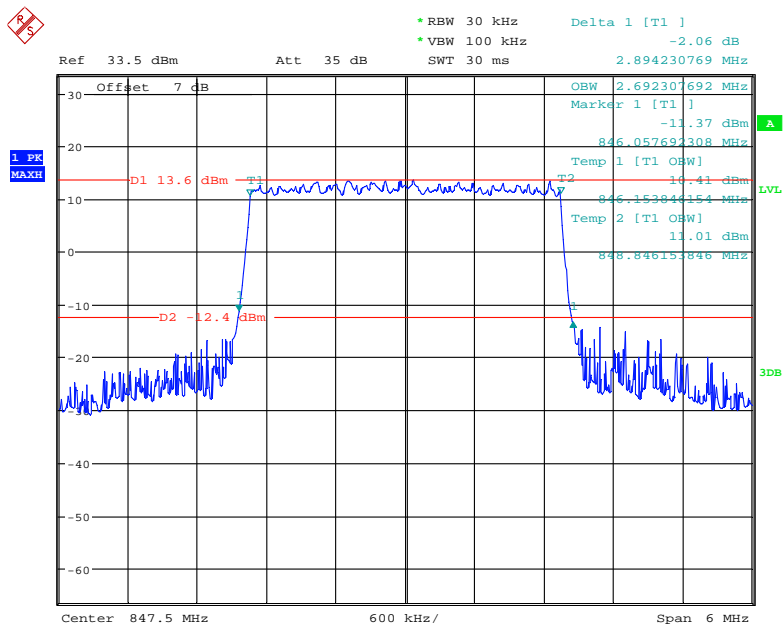

Date: 26.NOV.2020 08:47:53

Band 5_5 MHz_L_16QAM_RB25#0

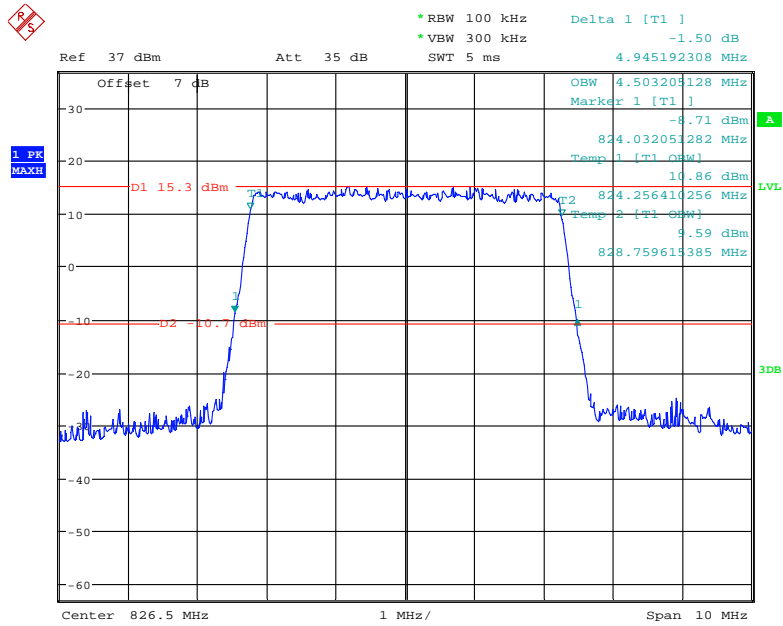

Date: 24.NOV.2020 19:00:29

Band 5_5 MHz_L_QP_RB25#0

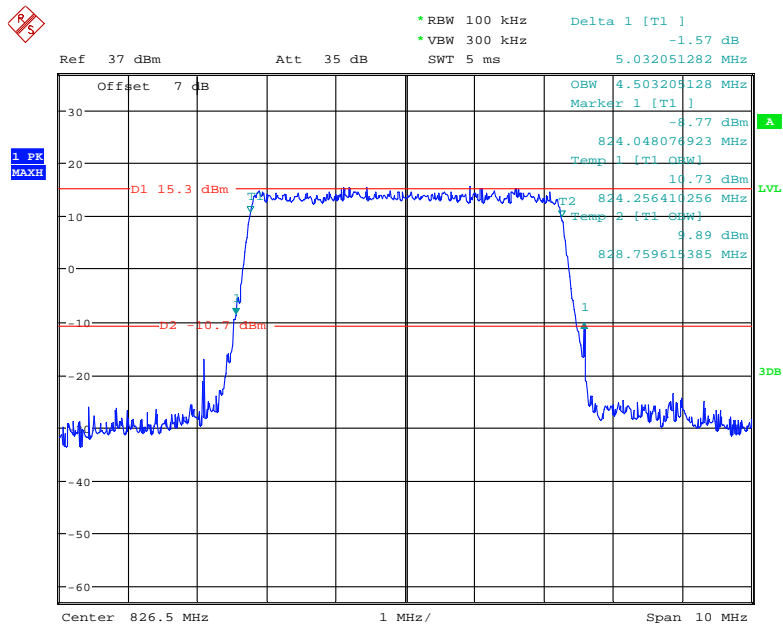

Date: 19.NOV.2020 11:19:22

Band 5_5 MHz_Middle_QPSK_RB25#0

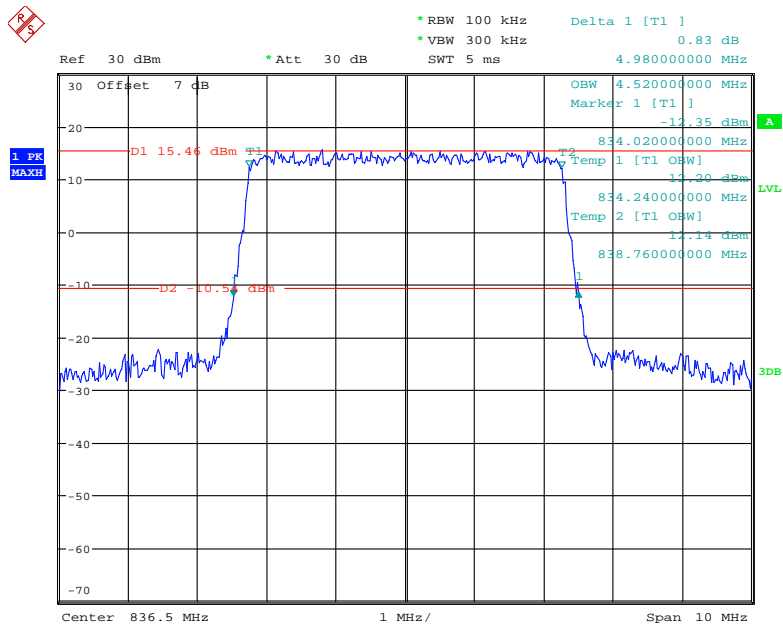

Date: 18.NOV.2020 14:36:40

Band 5_5 MHz_Middle_16QAM_RB25#0

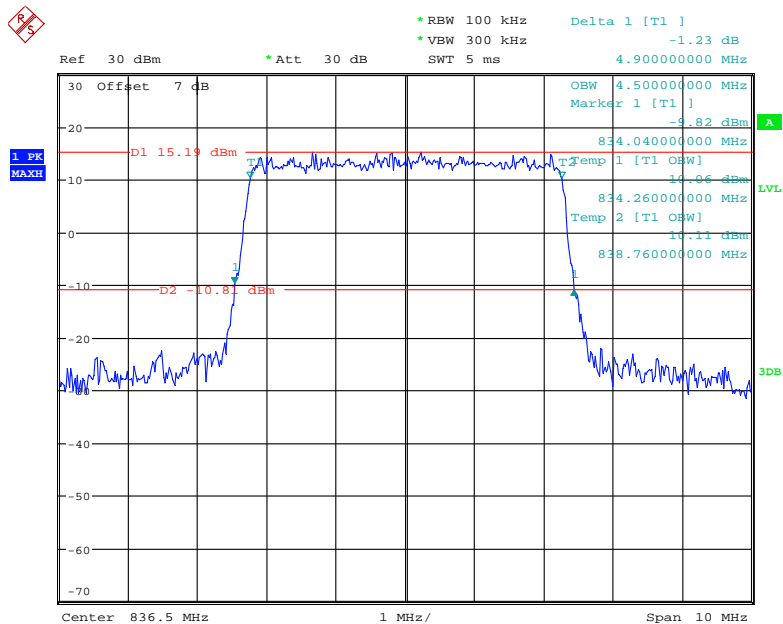

Date: 18.NOV.2020 14:37:04

Band 5_5 MHz_H_16QAM_RB25#0

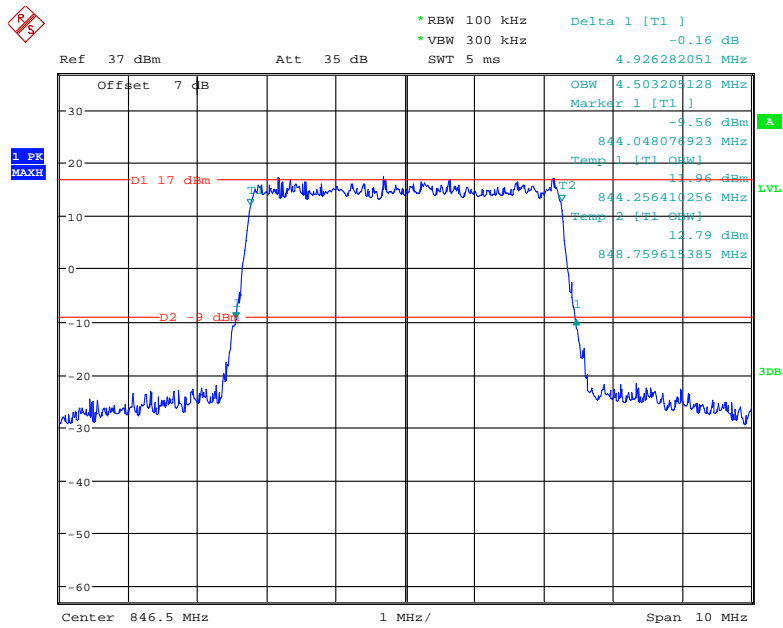

Date: 19.NOV.2020 11:21:53

Band 5_5 MHz_H_QPSK_RB25#0

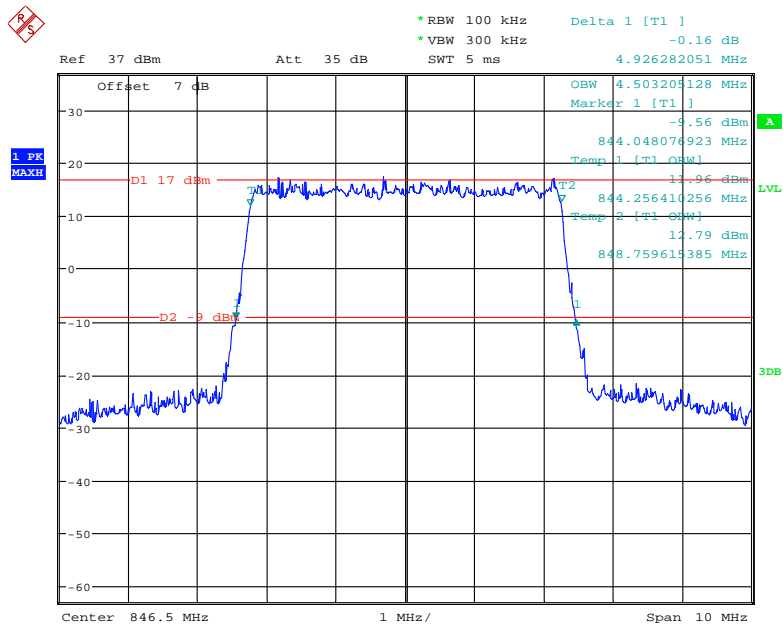

Date: 19.NOV.2020 11:21:53

Band 5_10 MHz_L_16QAM_RB50#0

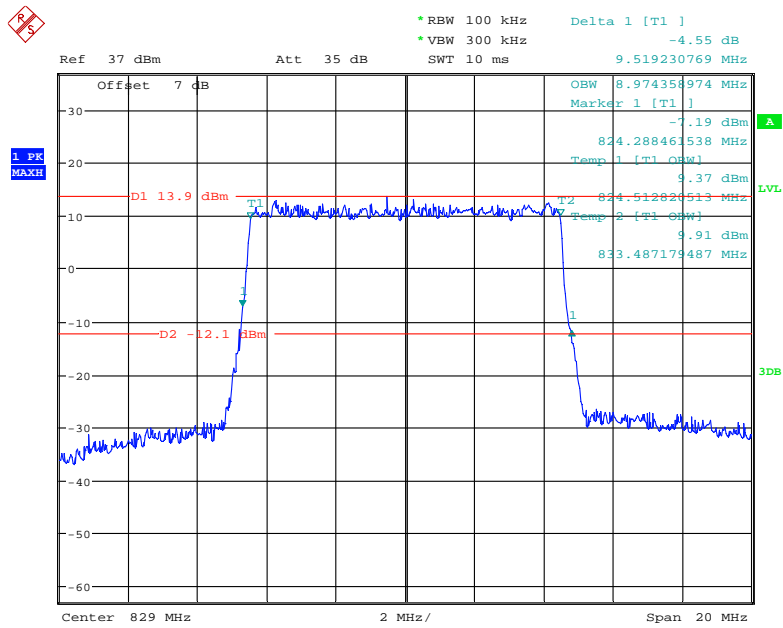

Date: 19.NOV.2020 11:24:29

Band 5_10 MHz_L_QPSK_RB50#0

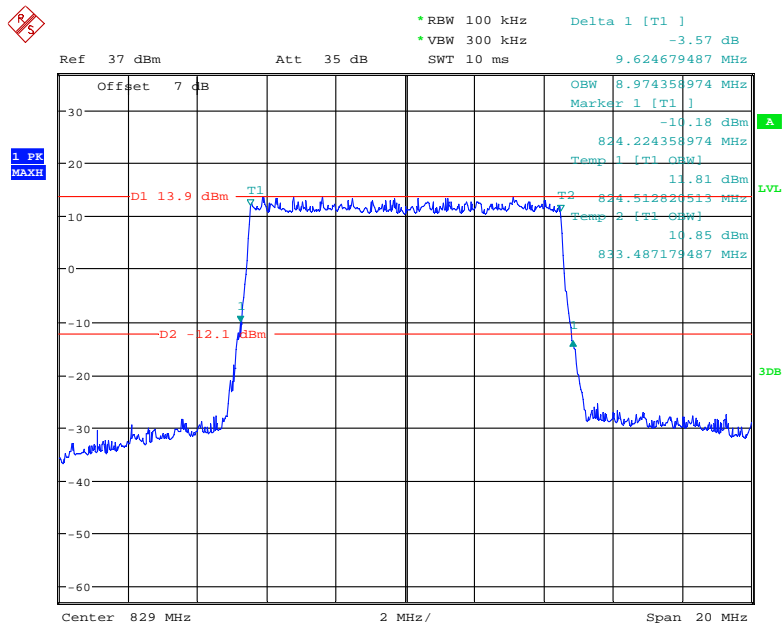

Date: 24.NOV.2020 19:02:46

Band 5_10 MHz_Middle_QPSK_RB50#0

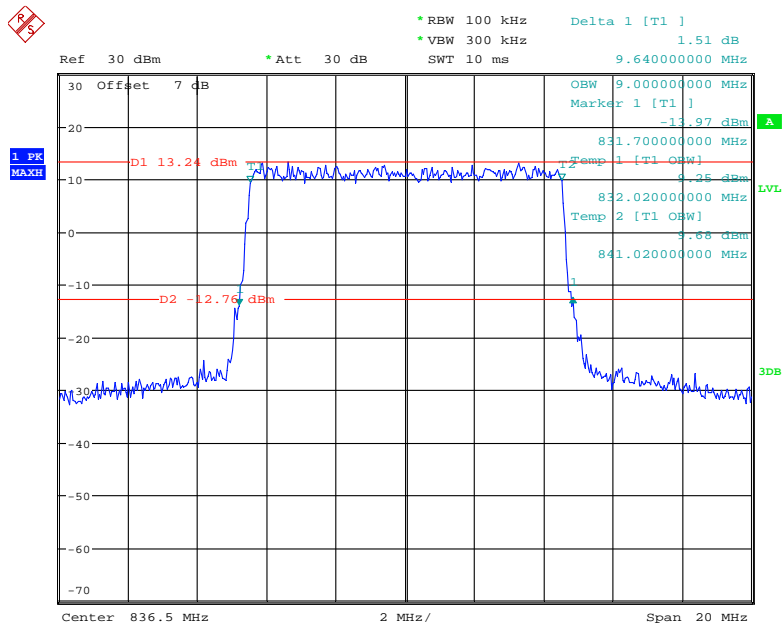

Date: 18.NOV.2020 14:37:28

Band 5_10 MHz_Middle_16QAM_RB50#0

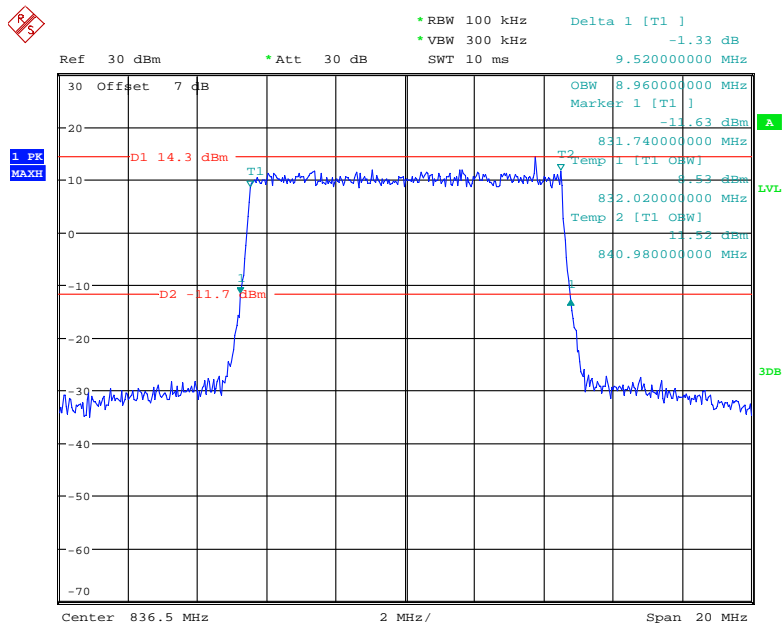

Date: 18.NOV.2020 14:37:50

Band 5_10 MHz_H_16QAM_RB50#0

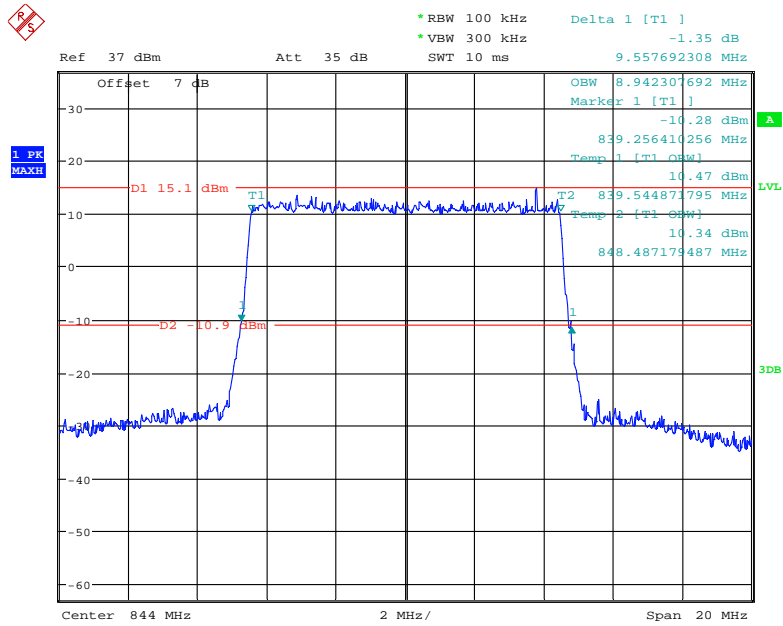

Date: 19.NOV.2020 11:25:35

Band 5_10 MHz_H_QPSK_RB50#0

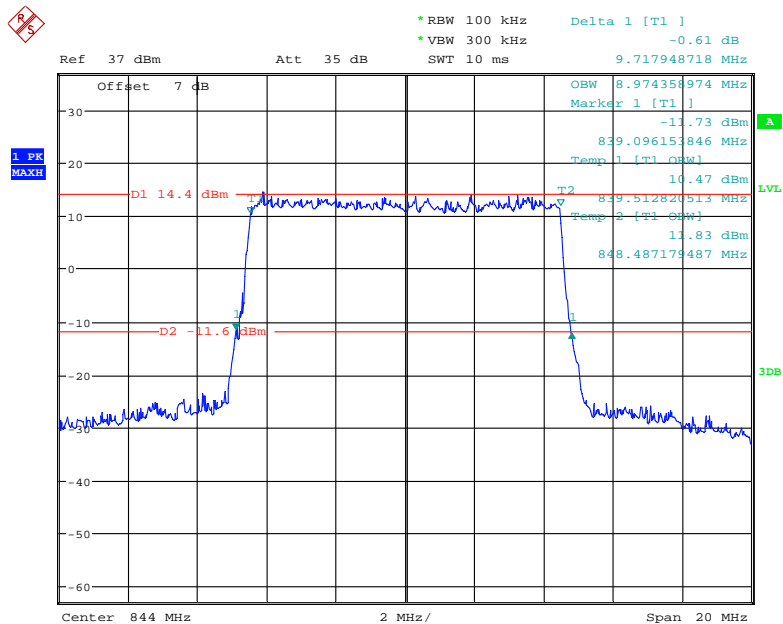

Date: 19.NOV.2020 11:26:17

Band 7

Bandwidth (MHz)	Modulation	Channel	99% Occupied Bandwidth (MHz)	26 dB Emission Bandwidth (MHz)
5	QPSK	Low	4.52	4.95
		Middle	4.52	4.96
		High	4.50	4.94
	16QAM	Low	4.52	4.93
		Middle	4.52	4.92
		High	4.50	4.94
10	QPSK	Low	8.97	9.60
		Middle	8.96	9.52
		High	8.97	9.54
	16QAM	Low	8.97	9.58
		Middle	8.96	9.60
		High	8.97	9.64
15	QPSK	Low	13.56	14.86
		Middle	13.56	14.82
		High	13.51	14.75
	16QAM	Low	13.56	14.76
		Middle	13.50	14.70
		High	13.51	14.82
20	QPSK	Low	17.95	19.36
		Middle	18.00	19.28
		High	18.01	19.22
	16QAM	Low	17.95	19.29
		Middle	18.00	19.36
		High	17.95	19.29

Band 7_5 MHz_L_16QAM_RB25#0

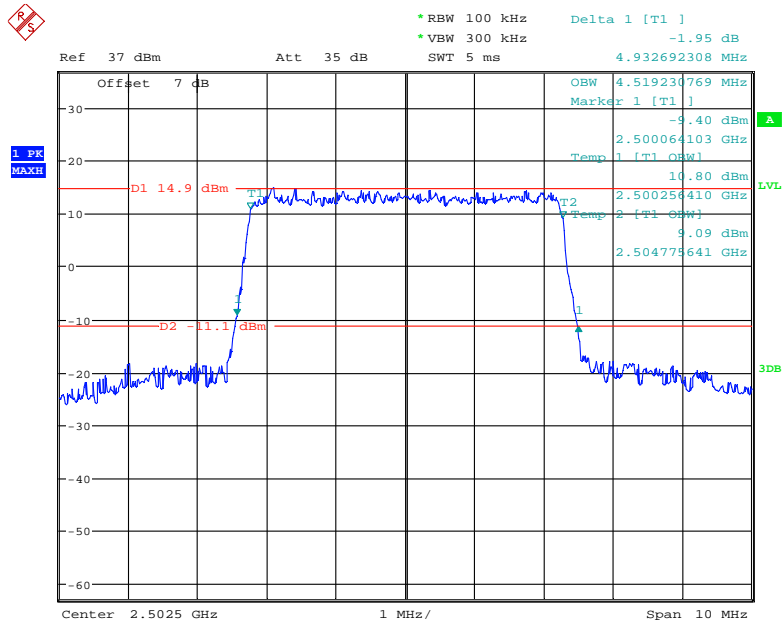

Date: 19.NOV.2020 11:27:33

Band 7_5 MHz_L_QPSK_RB25#0

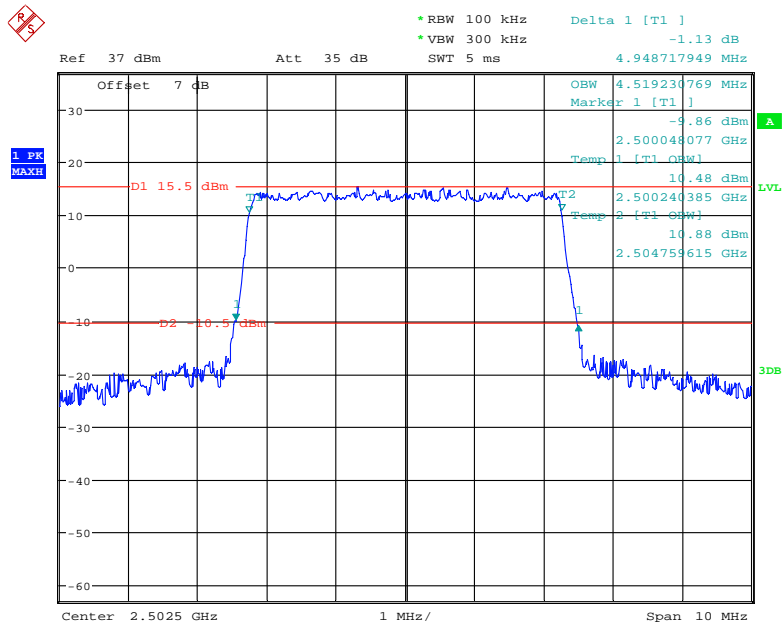

Date: 19.NOV.2020 11:28:54

Band 7_5 MHz_Middle_QPSK_RB25#0

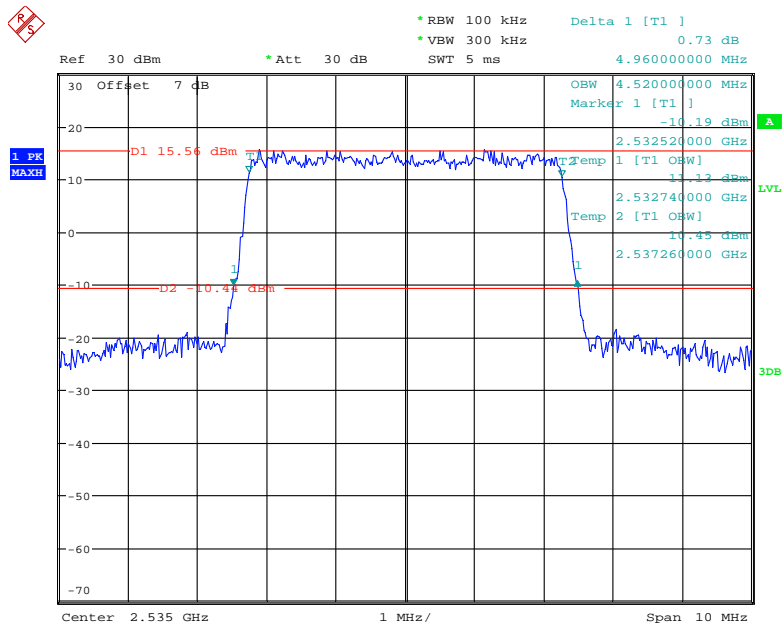

Date: 18.NOV.2020 14:38:17

Band 7_5 MHz_Middle_16QAM_RB25#0

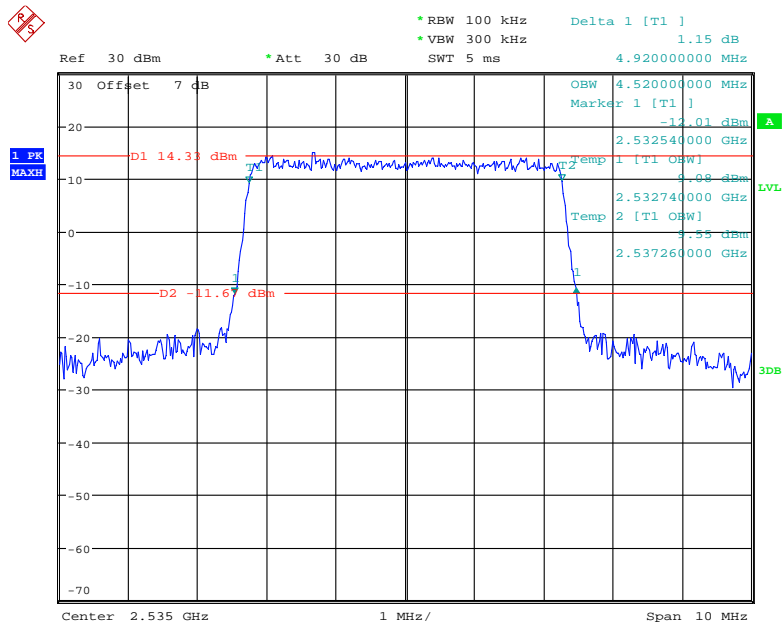

Date: 18.NOV.2020 14:38:38

Band 7_5 MHz_H_16QAM_RB25#0

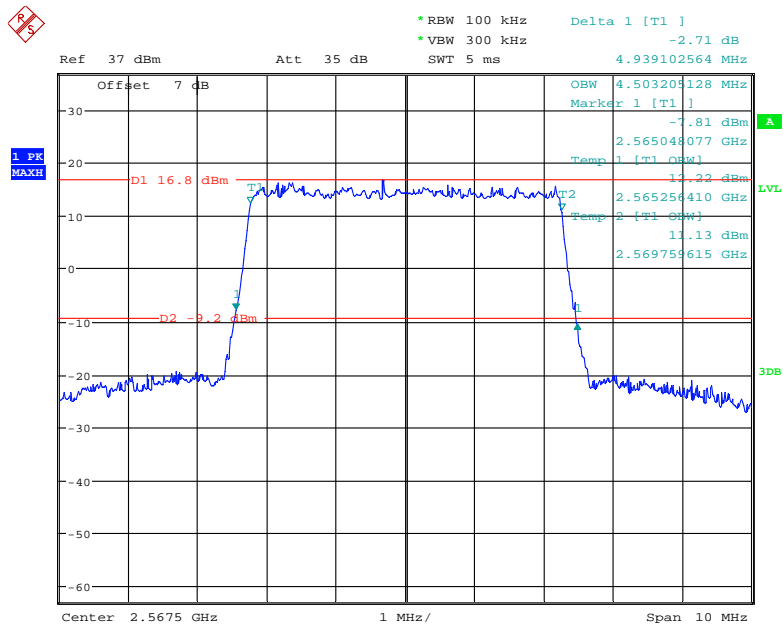

Date: 19.NOV.2020 11:31:51

Band 7_5 MHz_H_QPSK_RB25#0

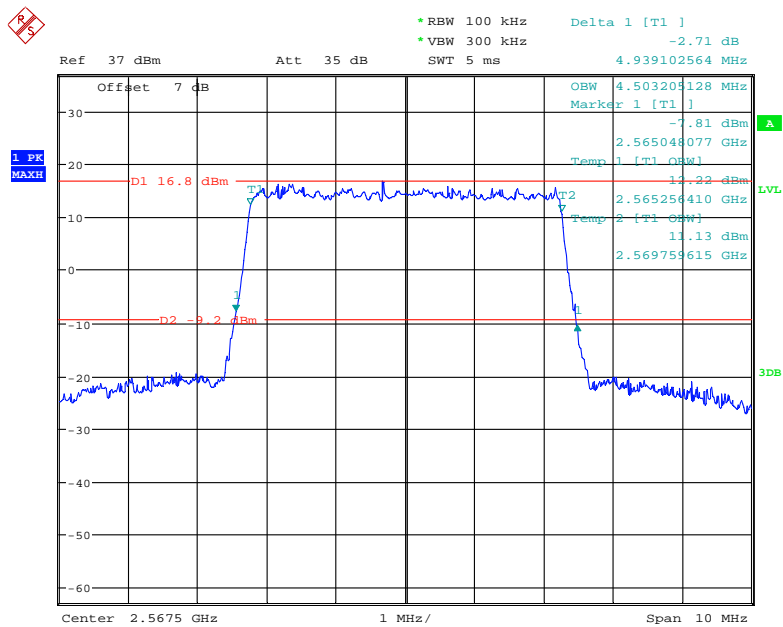

Date: 19.NOV.2020 11:31:51

Band 7_10 MHz_L_16QAM_RB50#0

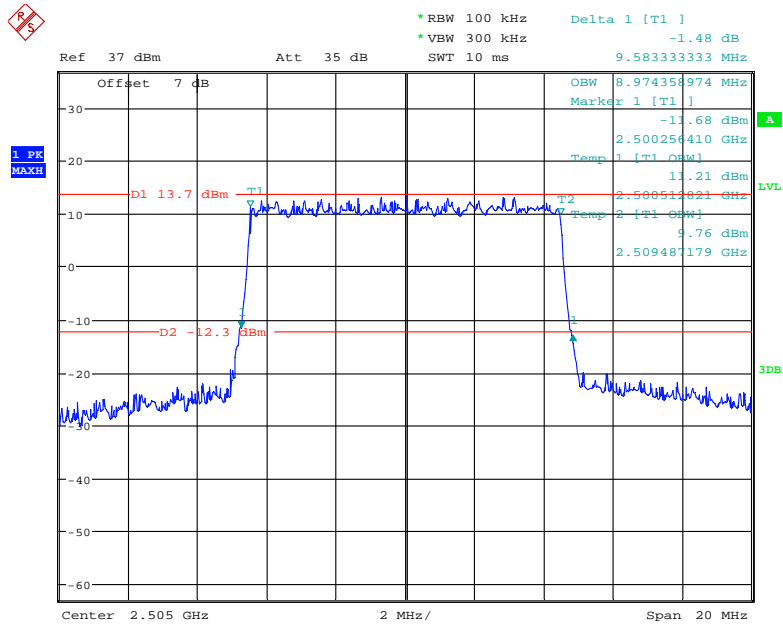

Date: 19.NOV.2020 11:34:17

Band 7_10 MHz_L_QPSK_RB50#0

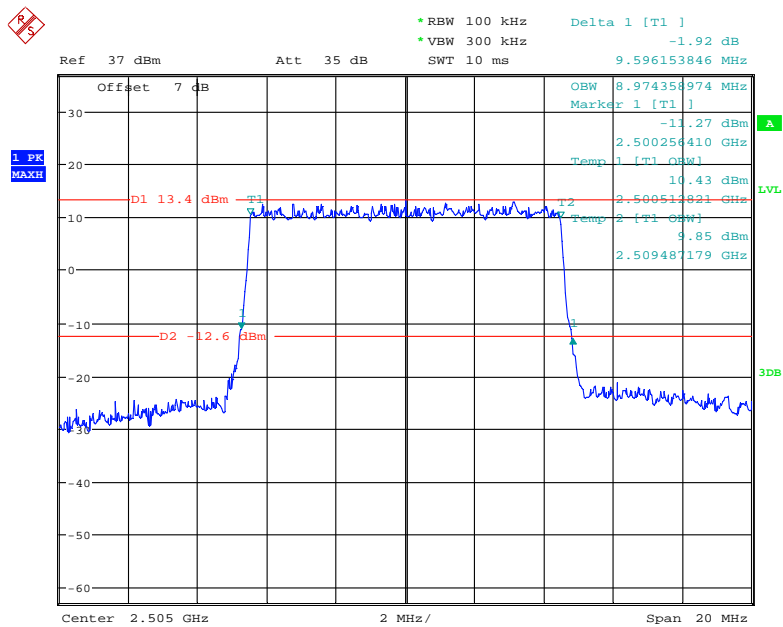

Date: 24.NOV.2020 19:05:07

Band 7_10 MHz_Middle_QPSK_RB50#0

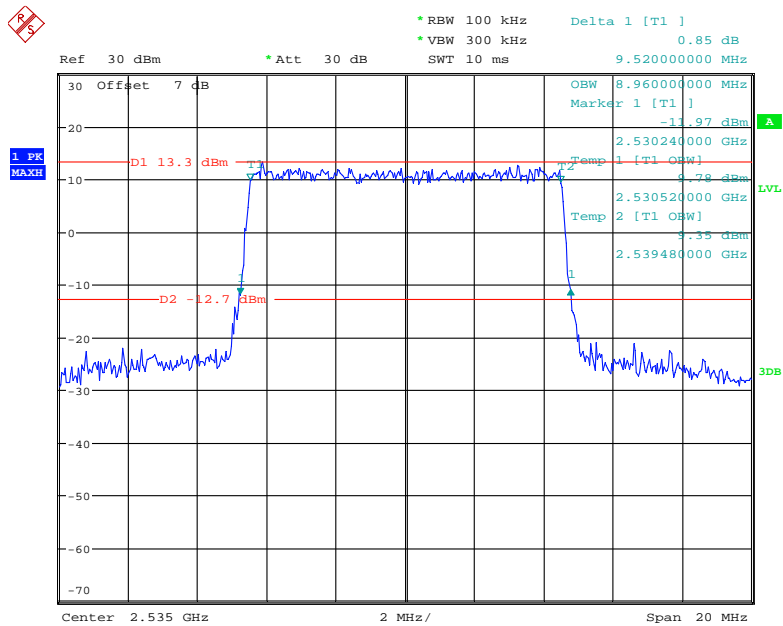

Date: 18.NOV.2020 14:38:59

Band 7_10 MHz_Middle_16QAM_RB50#0

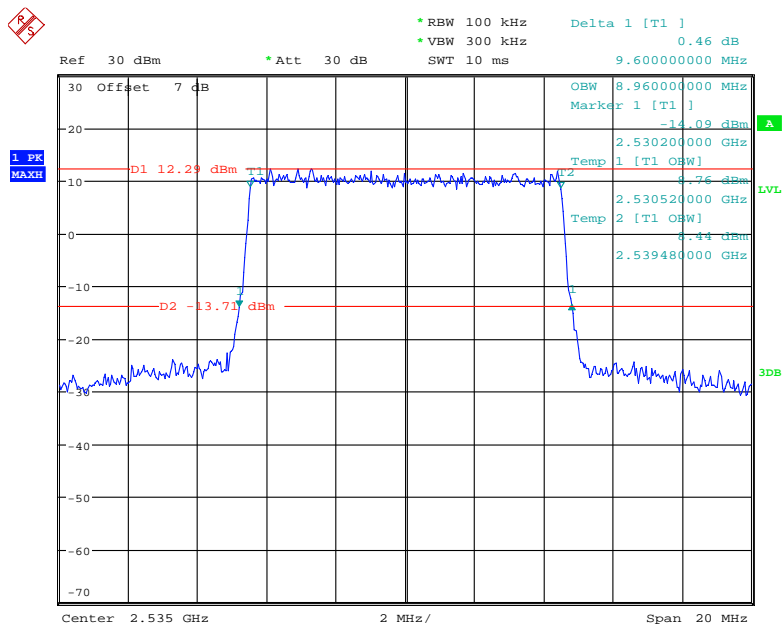

Date: 18.NOV.2020 14:39:21

Band 7_10 MHz_H_16QAM_RB50#0

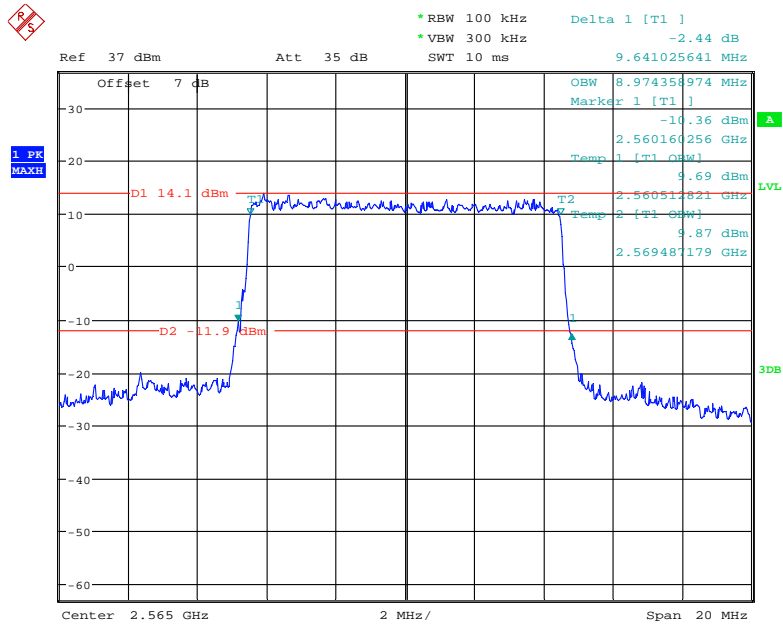

Date: 19.NOV.2020 11:37:52

Band 7_10 MHz_H_QPSK_RB50#0

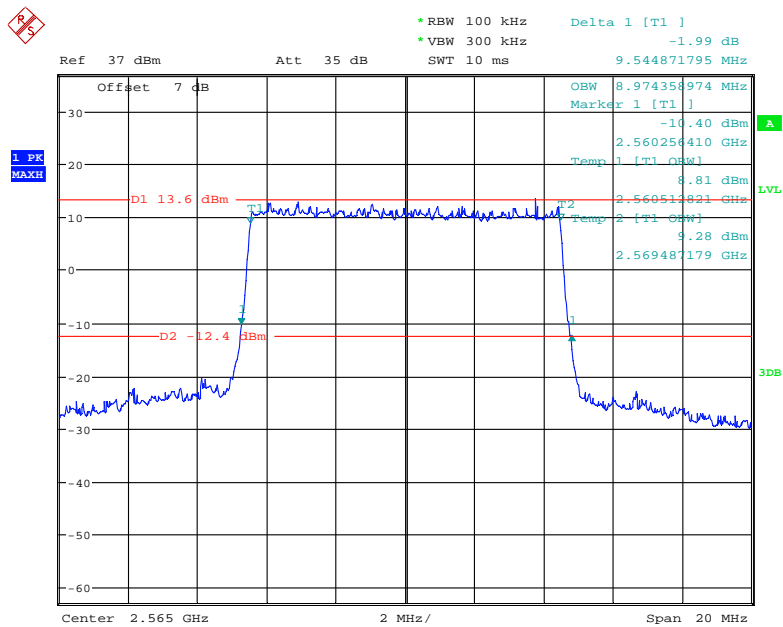

Date: 19.NOV.2020 11:37:10

Band 7_15 MHz_L_16QAM_RB75#0

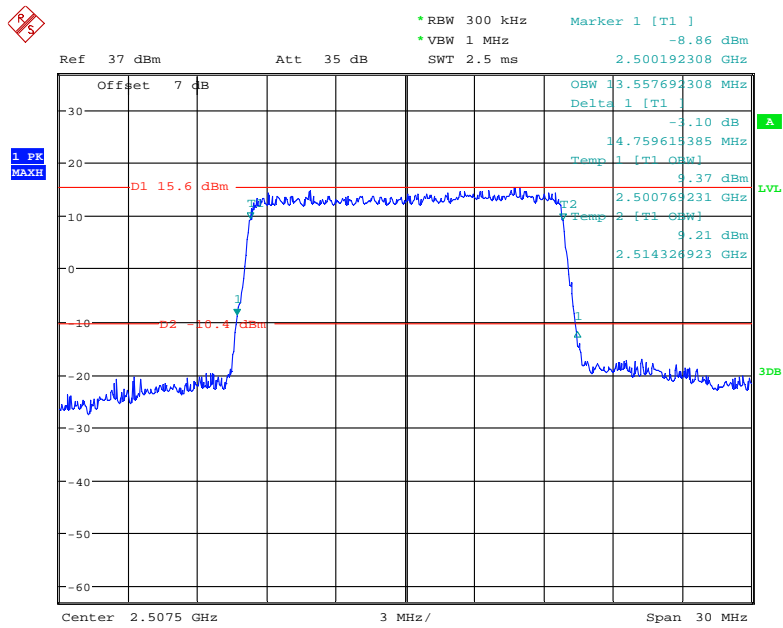

Date: 24.NOV.2020 19:13:20

Band 7_15 MHz_L_QPSK_RB75#0

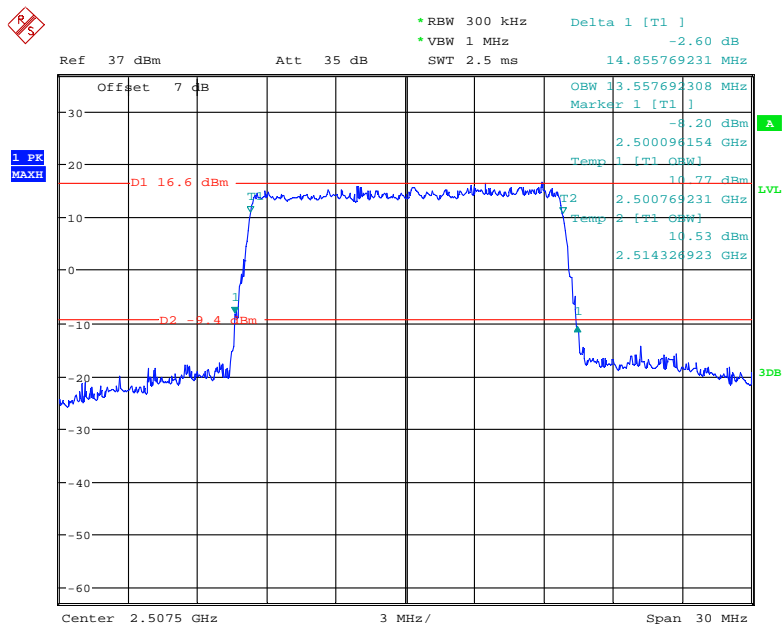

Date: 24.NOV.2020 19:12:35

Band 7_15 MHz_Middle_16QAM_RB75#0

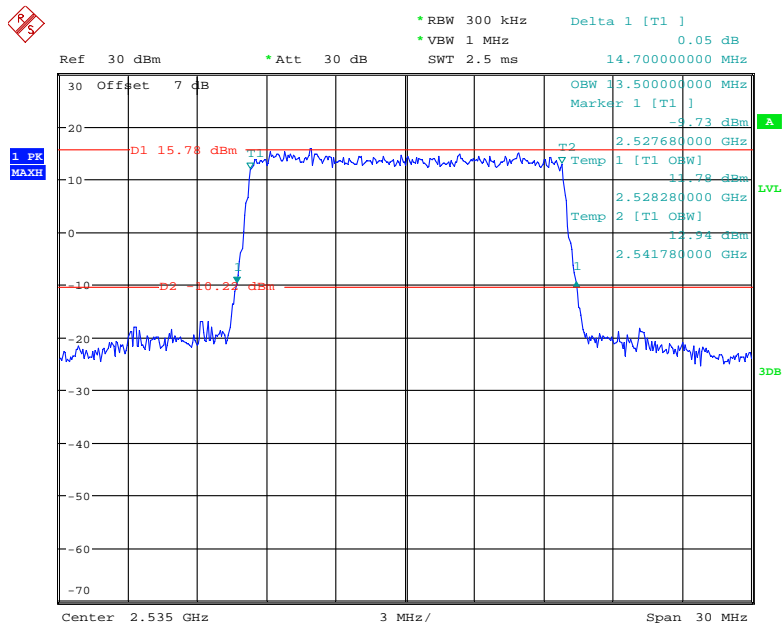

Date: 18.NOV.2020 14:40:19

Band 7_15 MHz_Middle_QPSK_RB75#0

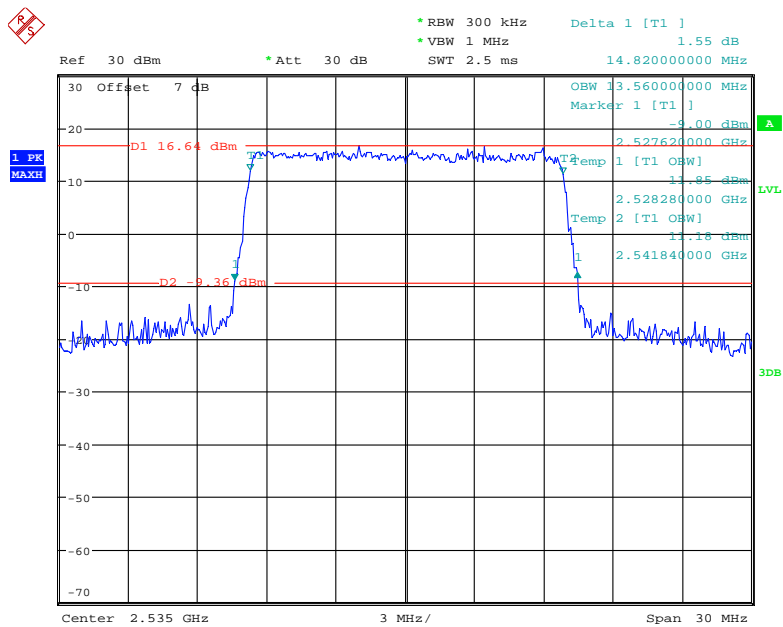

Date: 18.NOV.2020 14:39:54

Band 7_15 MHz_H_16QAM_RB75#0

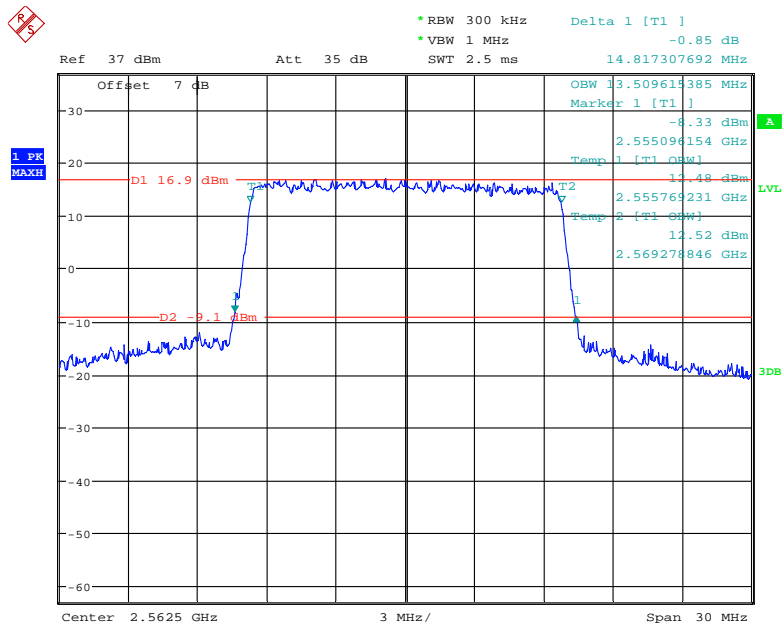

Date: 19.NOV.2020 11:41:47

Band 7_15 MHz_H_QPSK_RB75#0

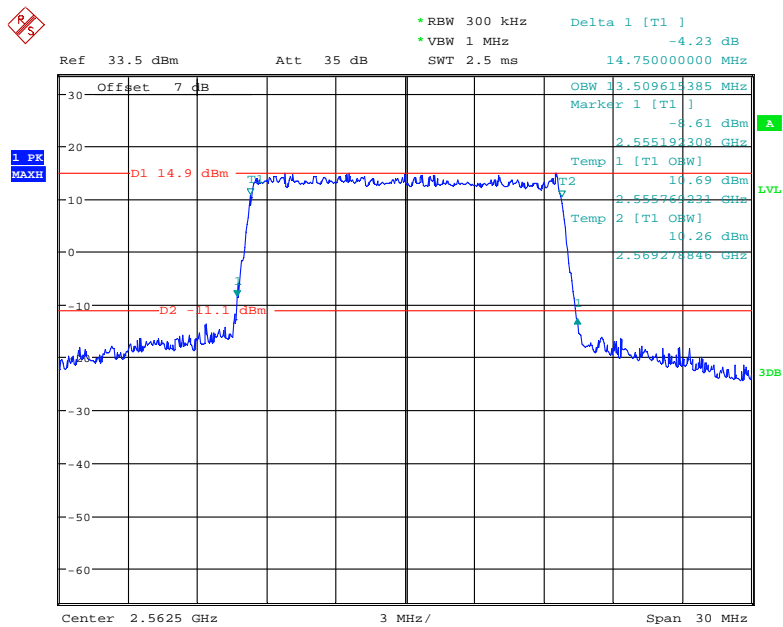

Date: 26.NOV.2020 08:49:50

Band 7_20 MHz_L_16QAM_RB100#0

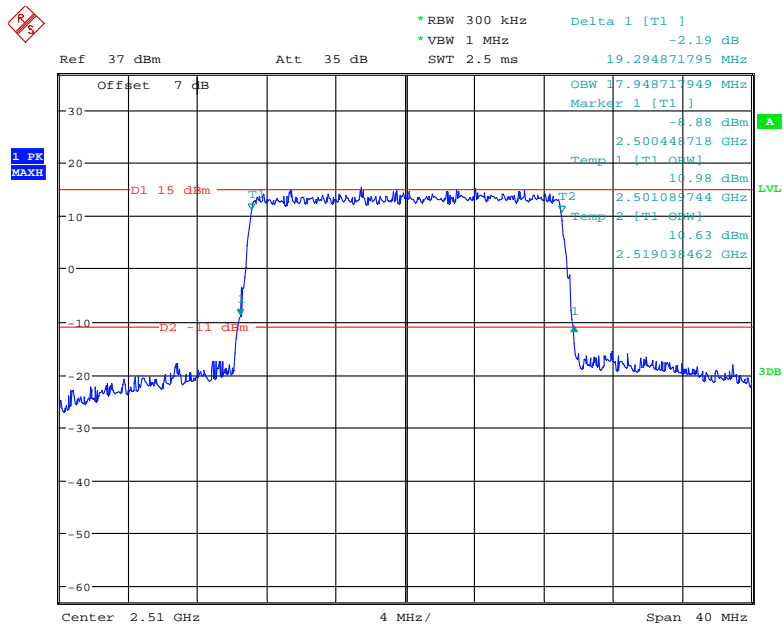

Date: 19.NOV.2020 11:43:53

Band 7_20 MHz_L_QPSK_RB100#0

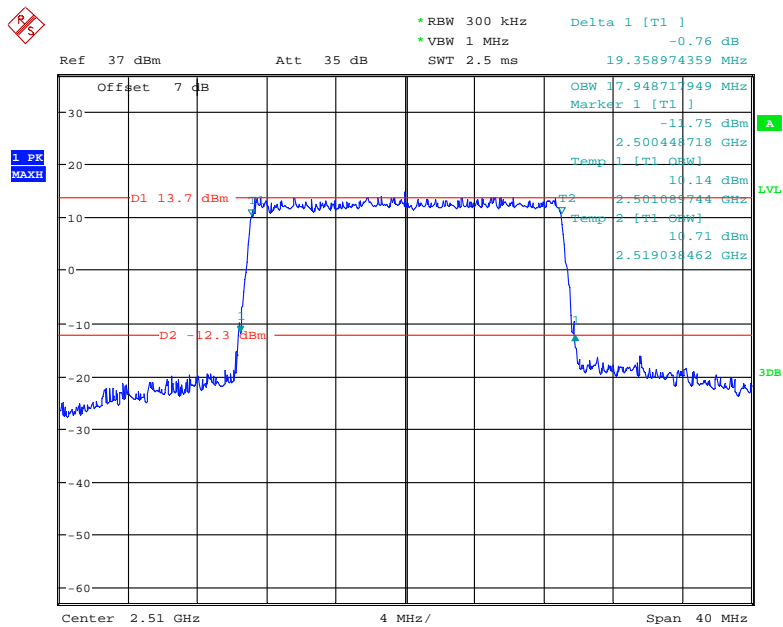

Date: 19.NOV.2020 11:44:44

Band 7_20 MHz_Middle_QPSK_RB100#0

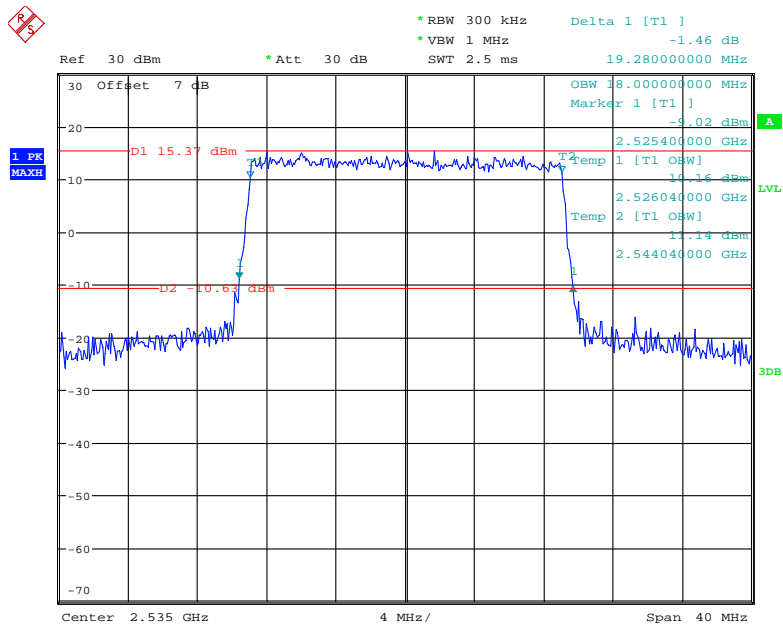

Date: 18.NOV.2020 14:40:46

Band 7_20 MHz_Middle_16QAM_RB100#0

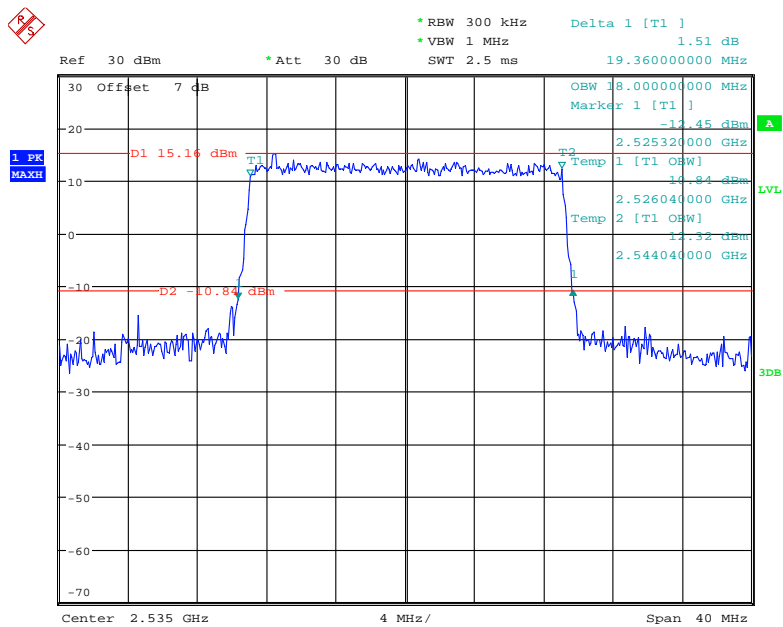

Date: 18.NOV.2020 14:41:11

Band 7_20 MHz_H_16QAM_RB100#0

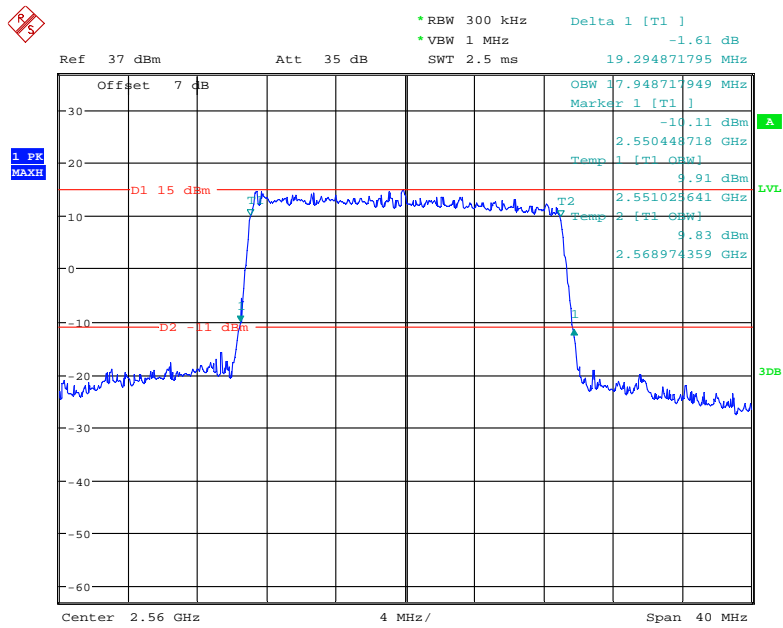

Date: 24.NOV.2020 19:14:50

Band 7_20 MHz_H_QPSK_RB100#0

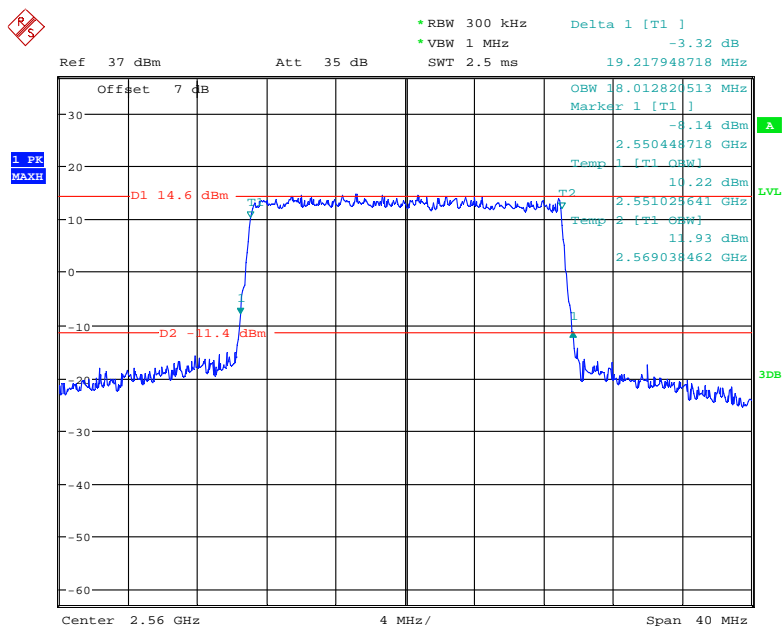

Date: 19.NOV.2020 11:45:43

LTE Band 38:

Bandwidth (MHz)	Modulation	Channel	99% Occupied Bandwidth (MHz)	26 dB Emission Bandwidth (MHz)
5	QPSK	Low	4.52	5.10
		Middle	4.50	5.20
		High	4.50	5.56
	16QAM	Low	4.50	4.95
		Middle	4.50	4.96
		High	4.50	5.03
10	QPSK	Low	8.97	9.46
		Middle	9.00	10.20
		High	8.97	9.71
	16QAM	Low	8.97	9.49
		Middle	9.00	9.52
		High	8.97	10.09
15	QPSK	Low	13.51	16.11
		Middle	13.56	15.12
		High	13.51	15.90
	16QAM	Low	13.51	15.58
		Middle	13.56	15.66
		High	13.51	15.90
20	QPSK	Low	18.01	20.71
		Middle	18.00	19.44
		High	18.01	19.30
	16QAM	Low	18.01	20.76
		Middle	18.00	19.36
		High	17.95	19.67

Band 38_5 MHz_L_16QAM_RB25#0

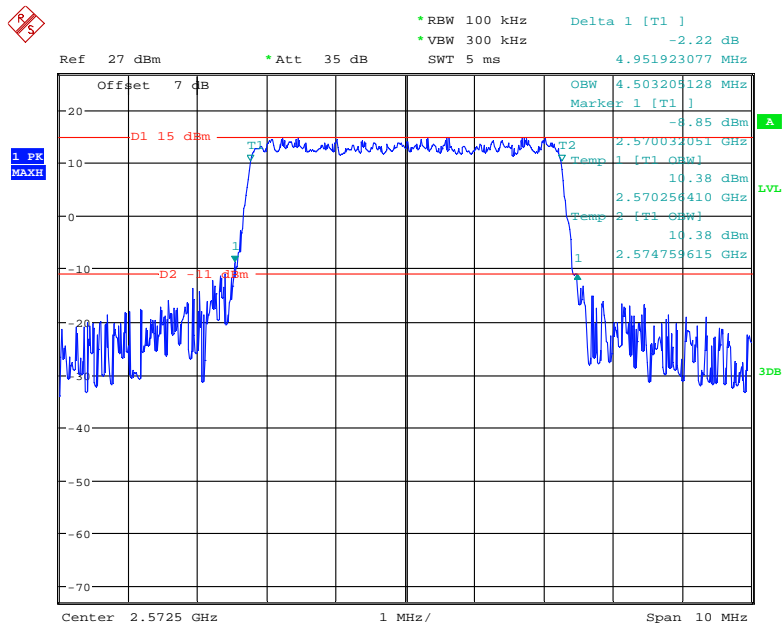

Date: 19.NOV.2020 12:08:47

Band 38_5 MHz_L_QPSK_RB25#0

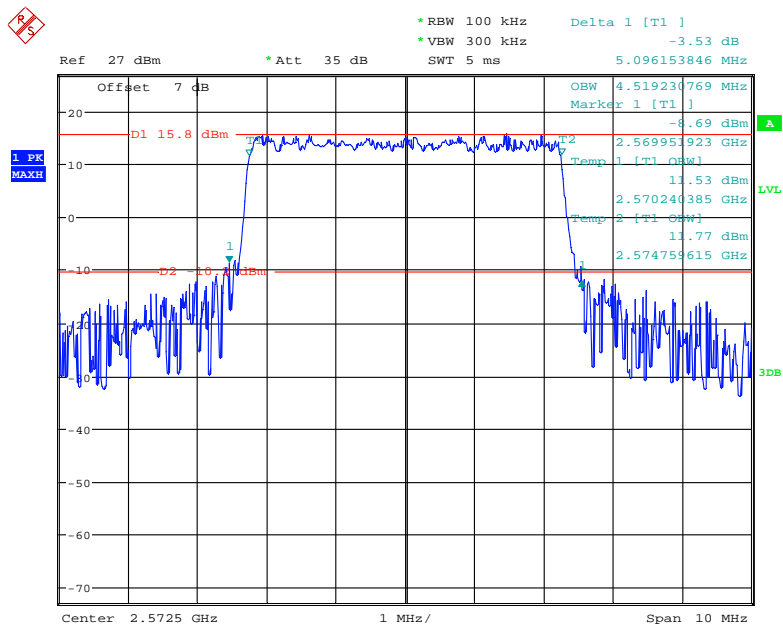

Date: 19.NOV.2020 12:09:43

Band 38_5 MHz_Middle_16QAM_RB25#0

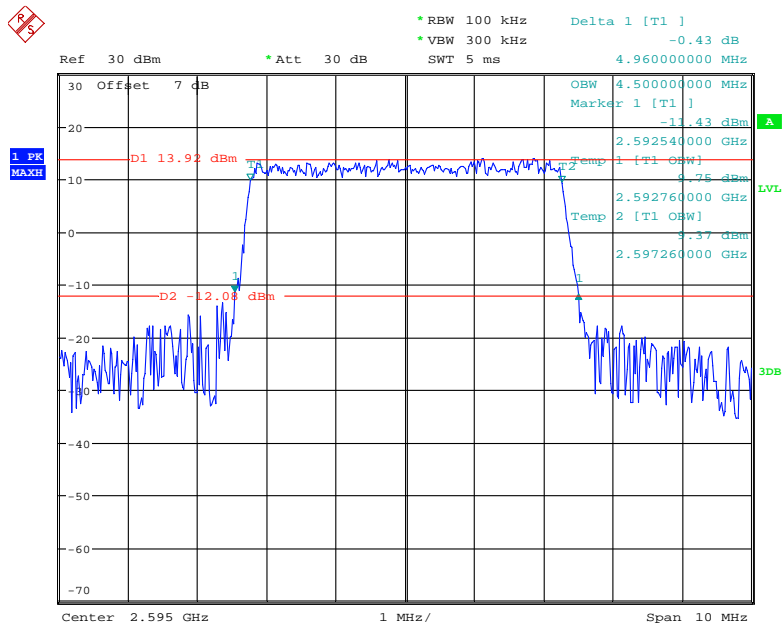

Date: 18.NOV.2020 15:38:10

Band 38_5 MHz_Middle_QPSK_RB25#0

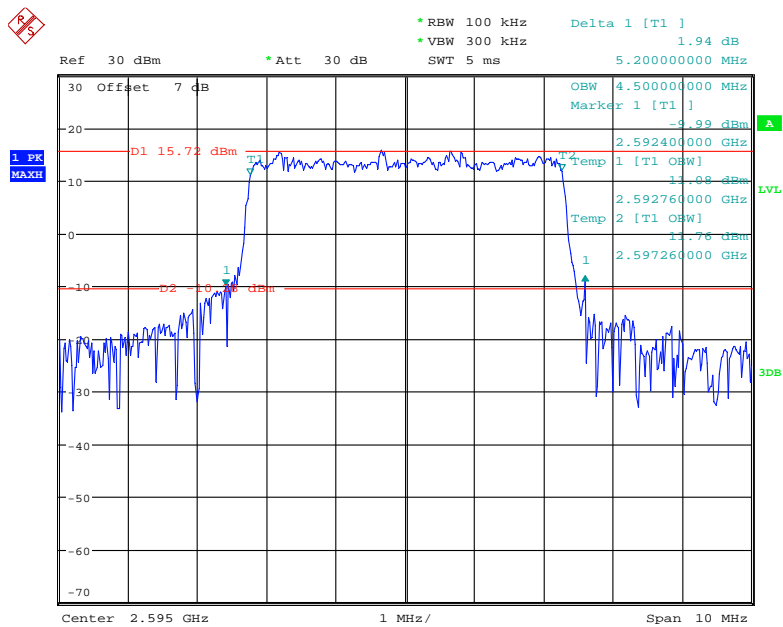

Date: 18.NOV.2020 15:37:42

Band 38_5 MHz_H_16QAM_RB25#0

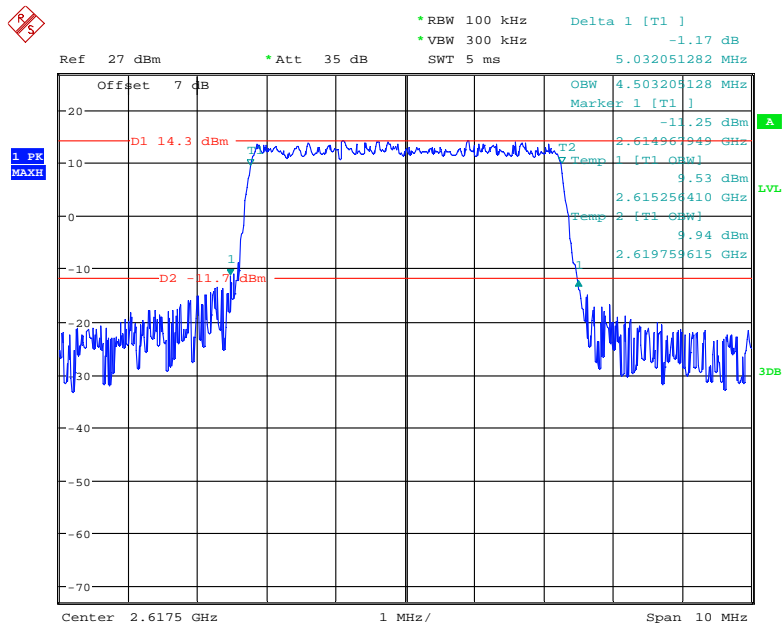

Date: 19.NOV.2020 12:13:17

Band 38_5 MHz_H_QPSK_RB25#0

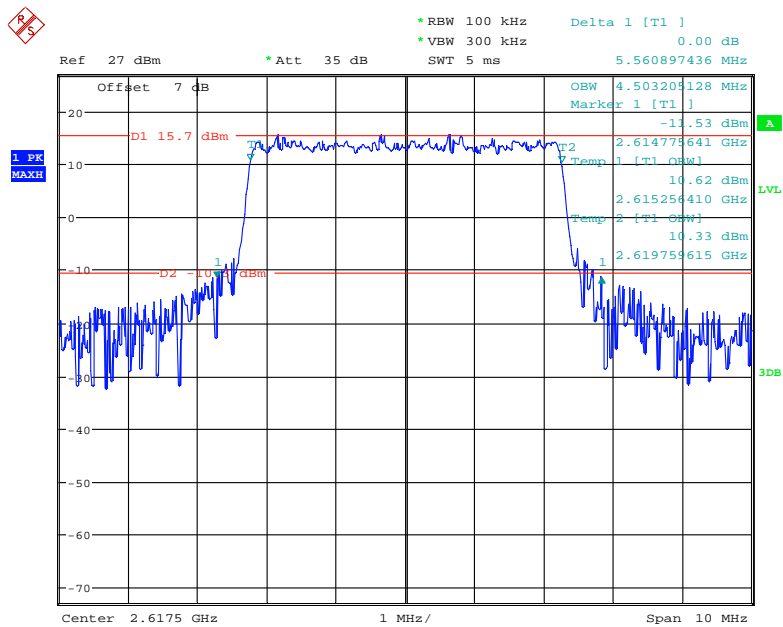

Date: 19.NOV.2020 12:12:05

Band 38_10 MHz_L_16QAM_RB50#0

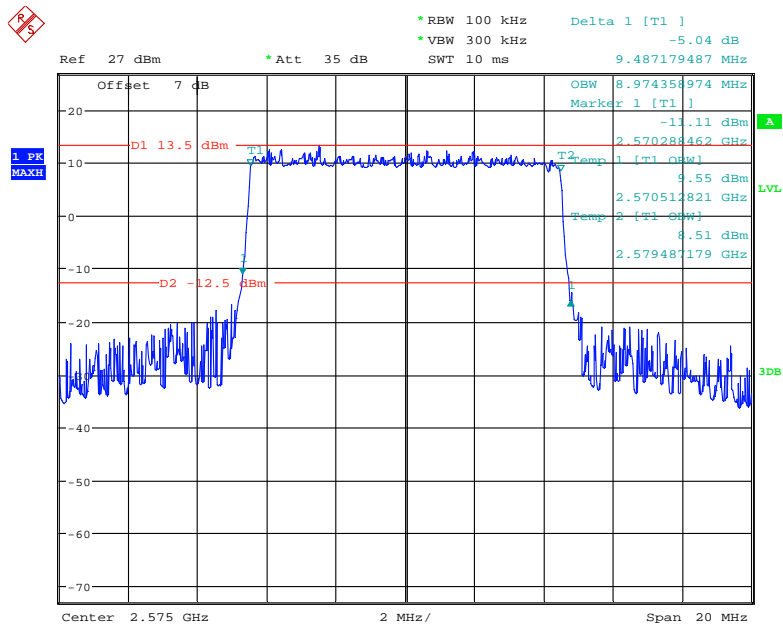

Date: 19.NOV.2020 12:05:25

Band 38_10 MHz_L_QPSK_RB50#0

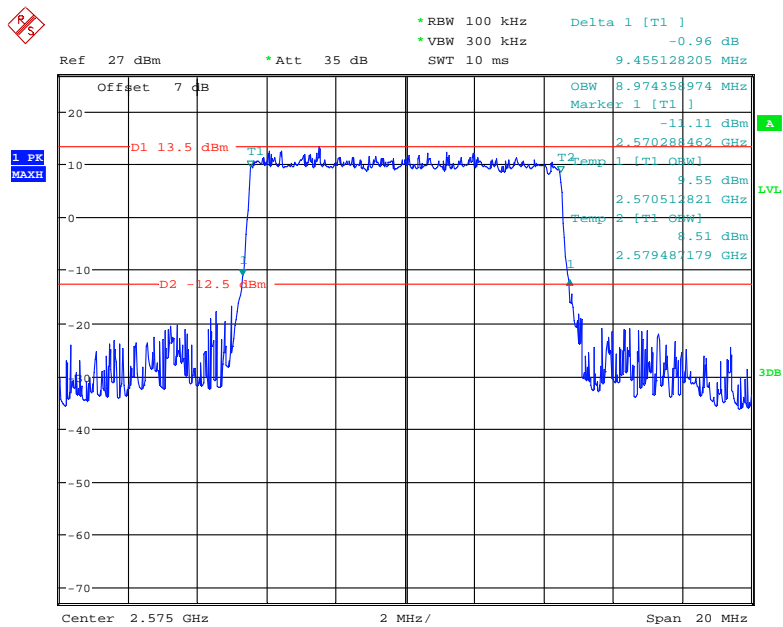

Date: 19.NOV.2020 12:05:16

Band 38_10 MHz_Middle_QPSK_RB50#0

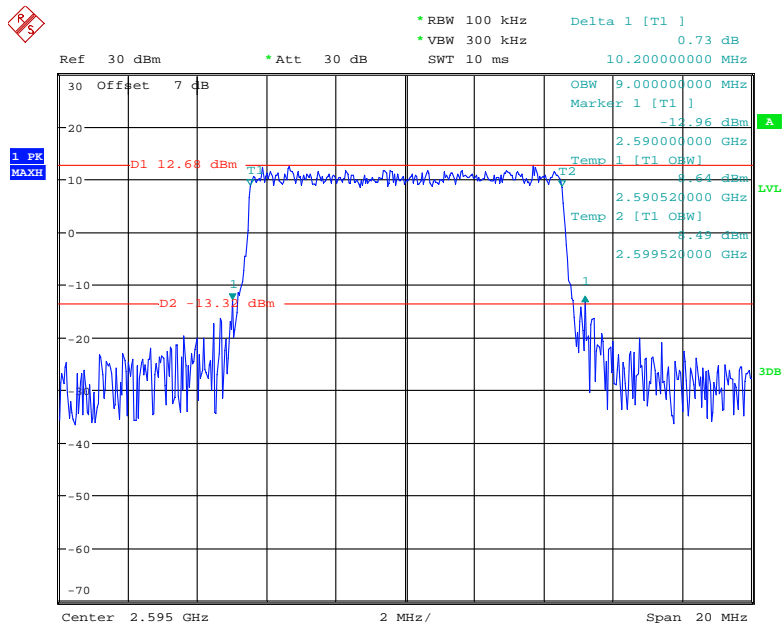

Date: 18.NOV.2020 15:38:40

Band 38_10 MHz_Middle_16QAM_RB50#0

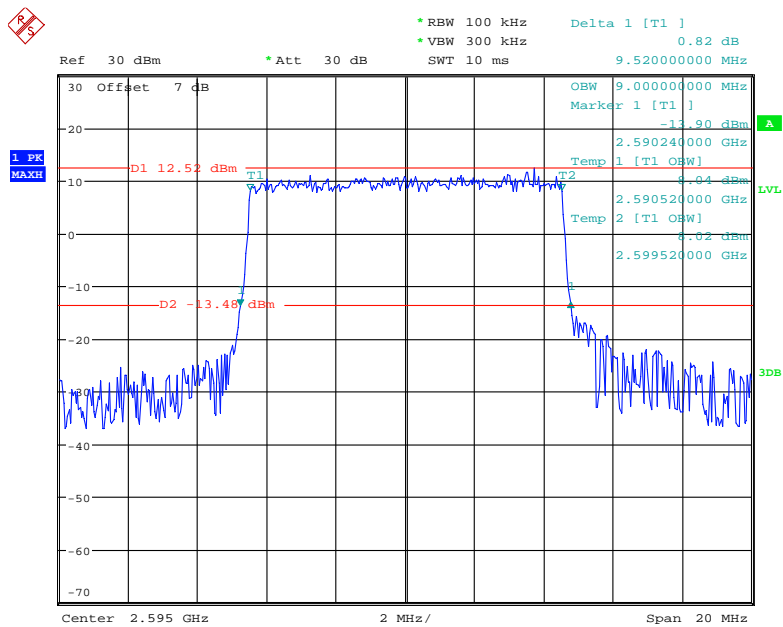

Date: 18.NOV.2020 15:39:08

Band 38_10 MHz_H_QPSK_RB50#0

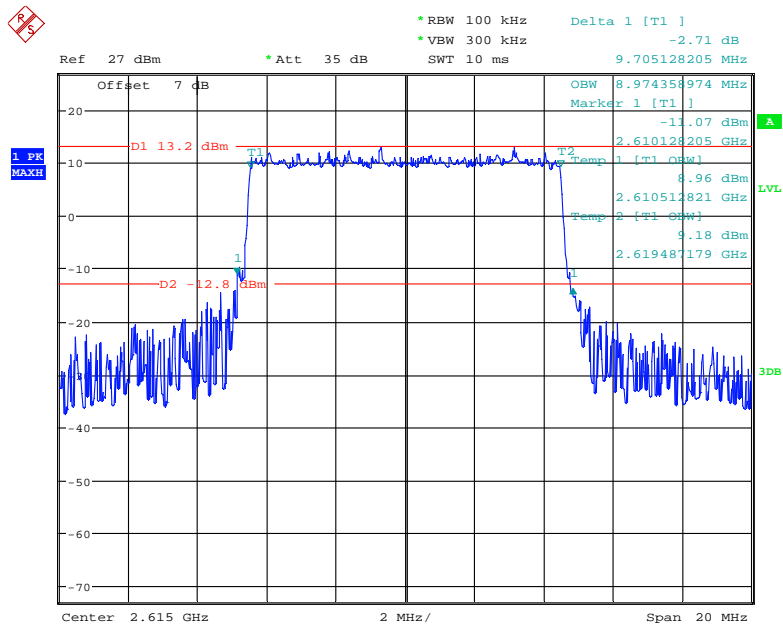

Date: 19.NOV.2020 12:07:26

Band 38_10 MHz_H_16QAM_RB50#0

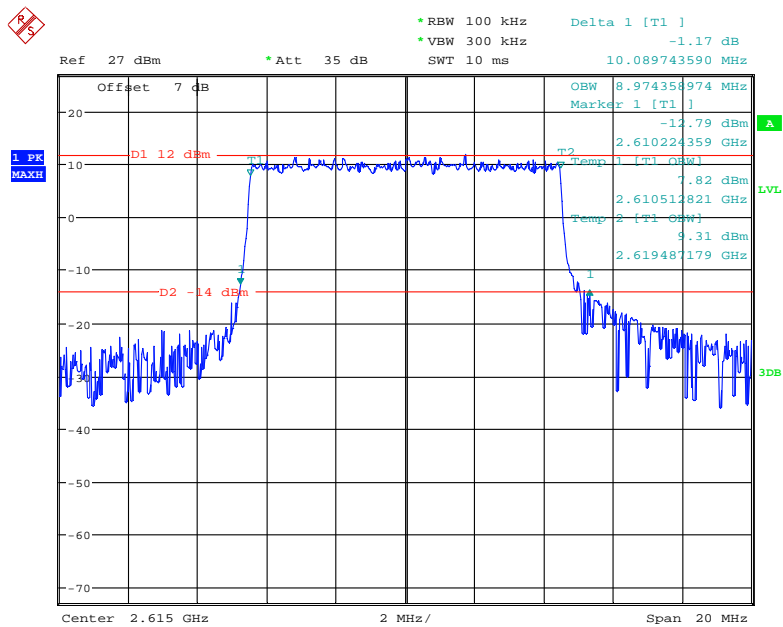

Date: 19.NOV.2020 12:06:43

Band 38_15 MHz_L_16QAM_RB75#0

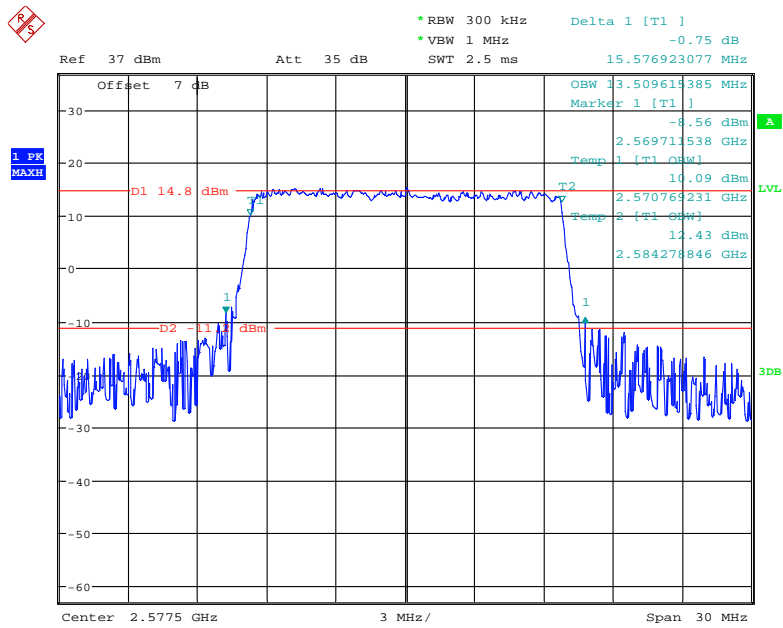

Date: 19.NOV.2020 11:57:28

Band 38_15 MHz_L_QPSK_RB75#0

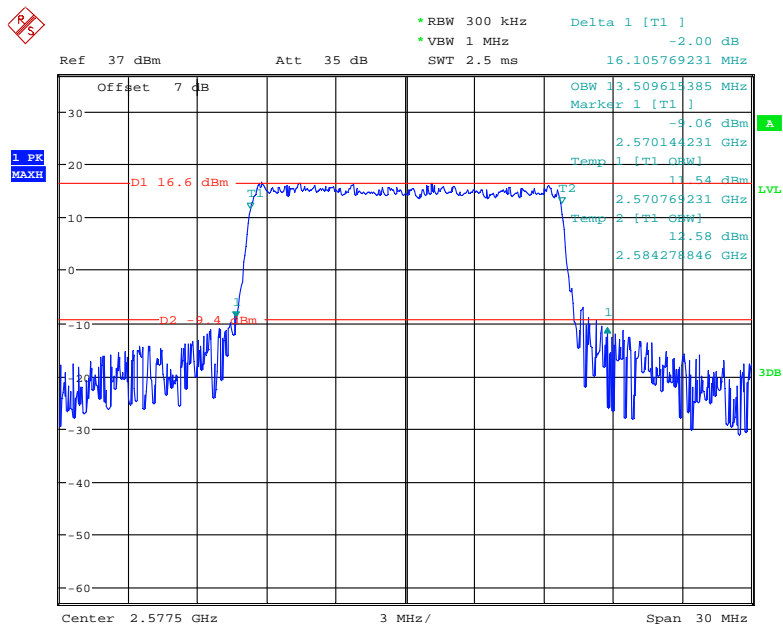

Date: 19.NOV.2020 11:59:09

Band 38_15 MHz_Middle_16QAM_RB75#0

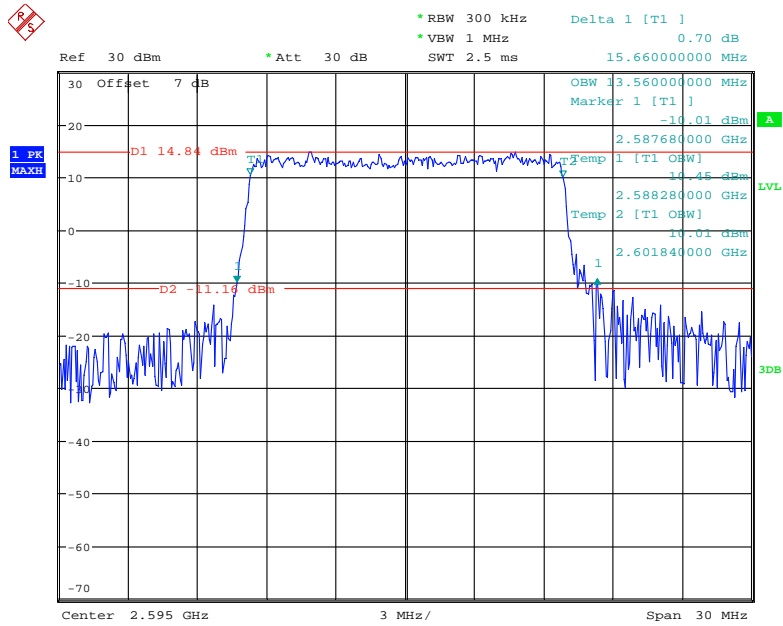

Date: 18.NOV.2020 15:40:25

Band 38_15 MHz_Middle_QPSK_RB75#0

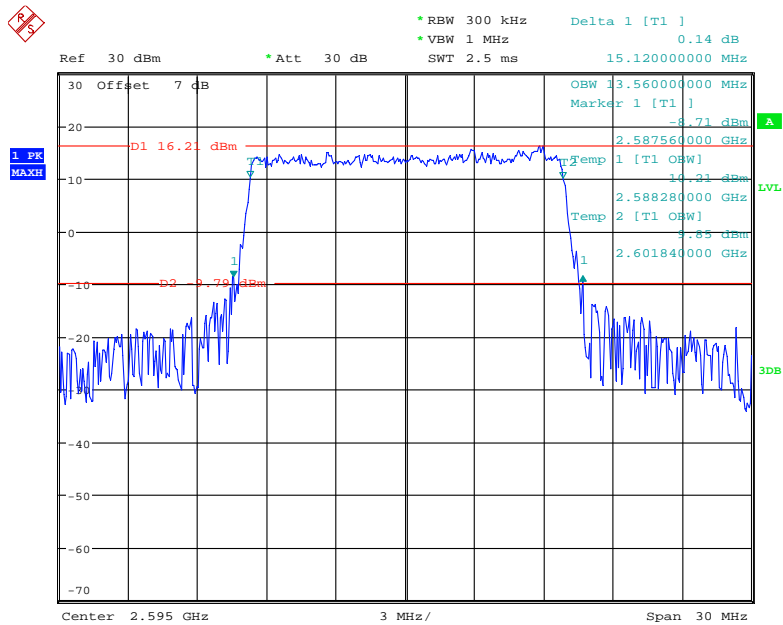

Date: 18.NOV.2020 15:39:44

Band 38_15 MHz_H_16QAM_RB75#0

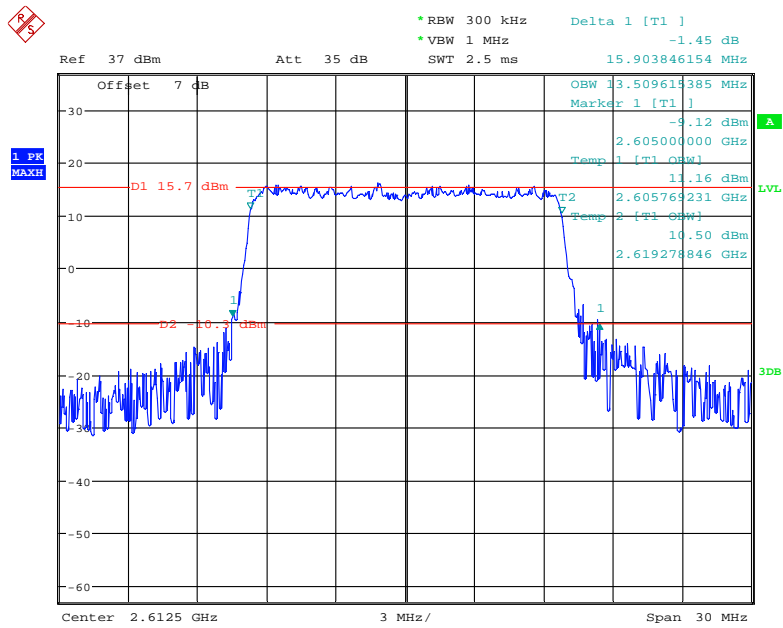

Date: 19.NOV.2020 12:00:37

Band 38_15 MHz_H_QPSK_RB75#0

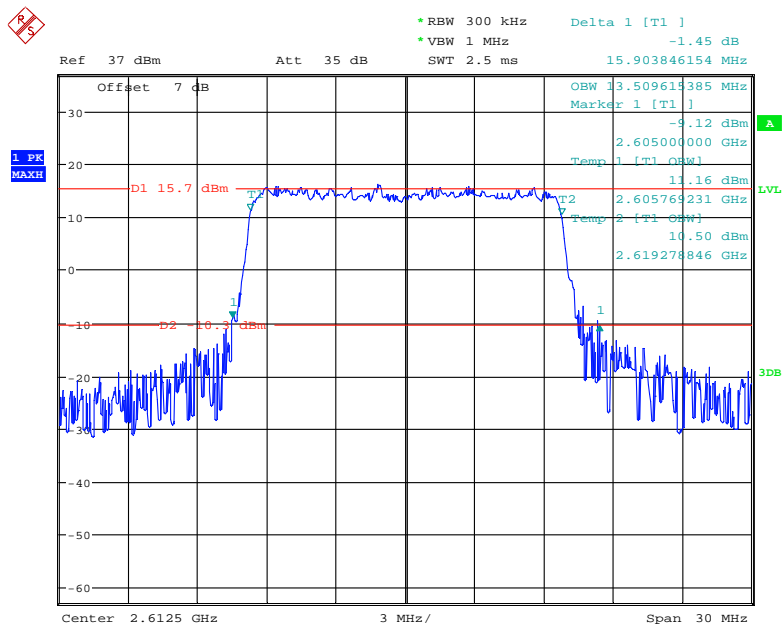

Date: 19.NOV.2020 12:00:37

Band 38_20 MHz_L_16QAM_RB100#0

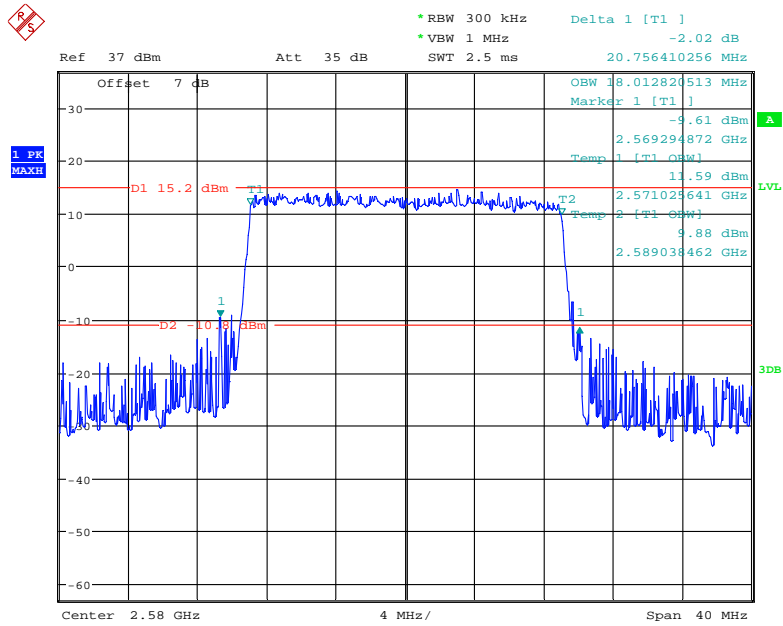

Date: 19.NOV.2020 11:53:15

Band 38_20 MHz_L_QPSK_RB100#0

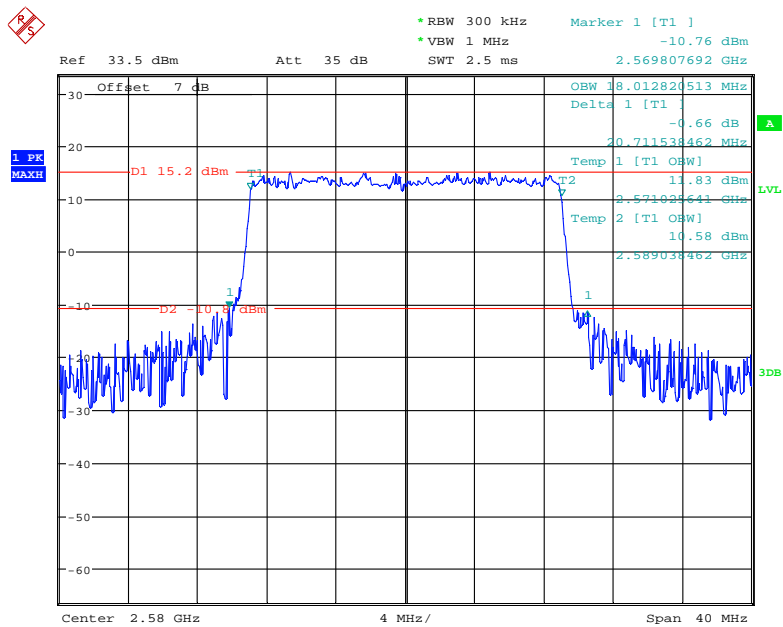

Date: 26.NOV.2020 08:57:46

Band 38_20 MHz_Middle_QPSK_RB100#0

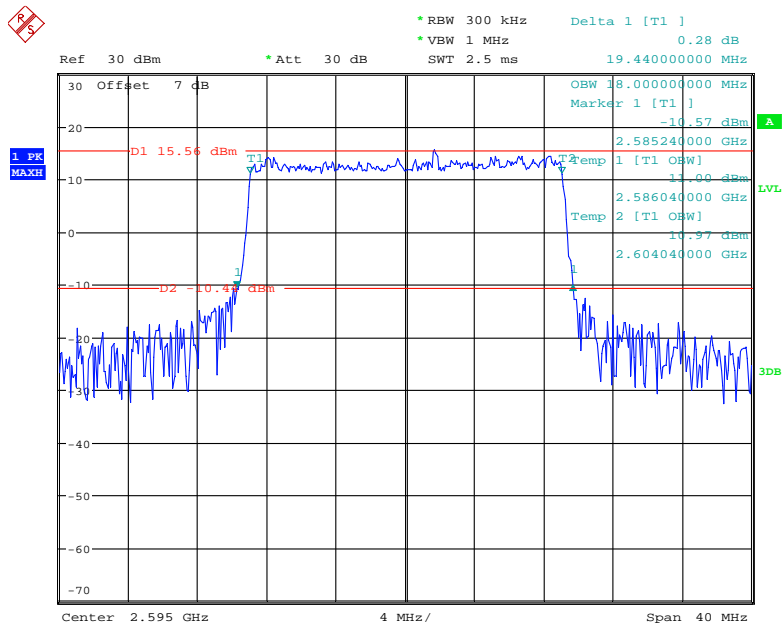

Date: 18.NOV.2020 15:41:06

Band 38_20 MHz_Middle_16QAM_RB100#0

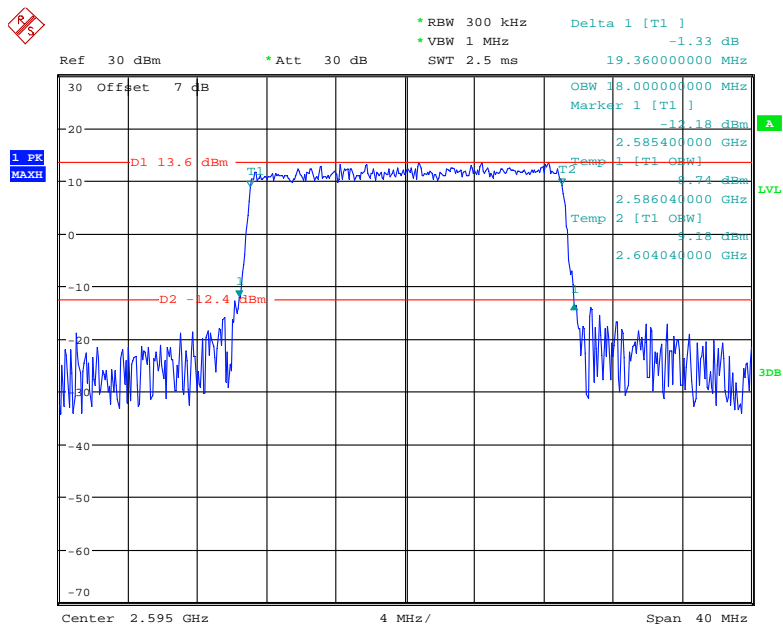

Date: 18.NOV.2020 15:41:35

Band 38_20 MHz_H_16QAM_RB100#0

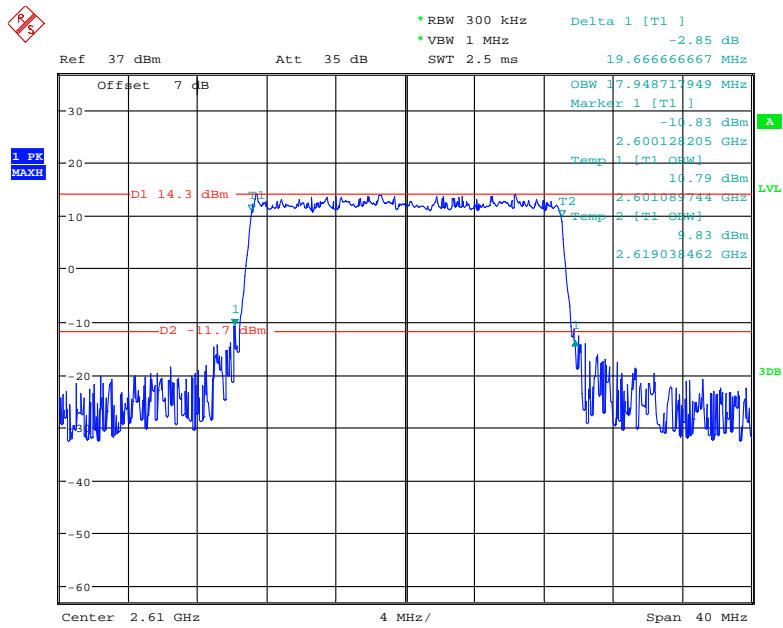

Date: 19.NOV.2020 11:54:48

Band 38_20 MHz_H_QPSK_RB100#0

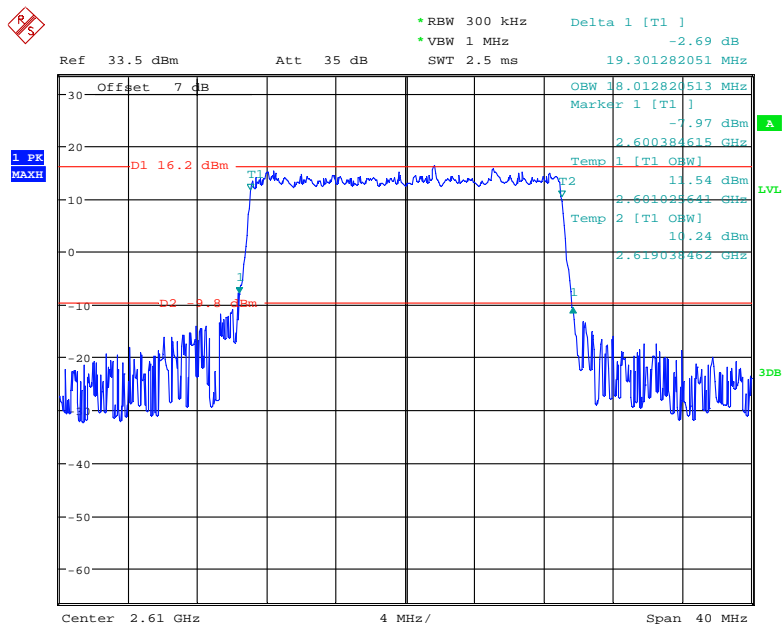

Date: 26.NOV.2020 08:59:17

LTE Band 41:

Bandwidth (MHz)	Modulation	Channel	99% Occupied Bandwidth (MHz)	26 dB Emission Bandwidth (MHz)
5	QPSK	Low	4.50	5.30
		Middle	4.50	4.96
		High	4.50	4.98
	16QAM	Low	4.50	5.06
		Middle	4.52	5.12
		High	4.51	5.35
10	QPSK	Low	8.94	9.87
		Middle	8.96	9.68
		High	8.97	10.10
	16QAM	Low	8.97	9.58
		Middle	9.00	9.52
		High	8.97	10.00
15	QPSK	Low	13.65	15.72
		Middle	13.56	15.36
		High	13.56	15.82
	16QAM	Low	13.61	17.02
		Middle	13.56	16.20
		High	13.65	16.01
20	QPSK	Low	18.01	19.74
		Middle	18.00	19.28
		High	17.94	19.59
	16QAM	Low	17.95	19.74
		Middle	18.00	20.00
		High	18.01	21.58

Band 41_5 MHz_L_16QAM_RB25#0

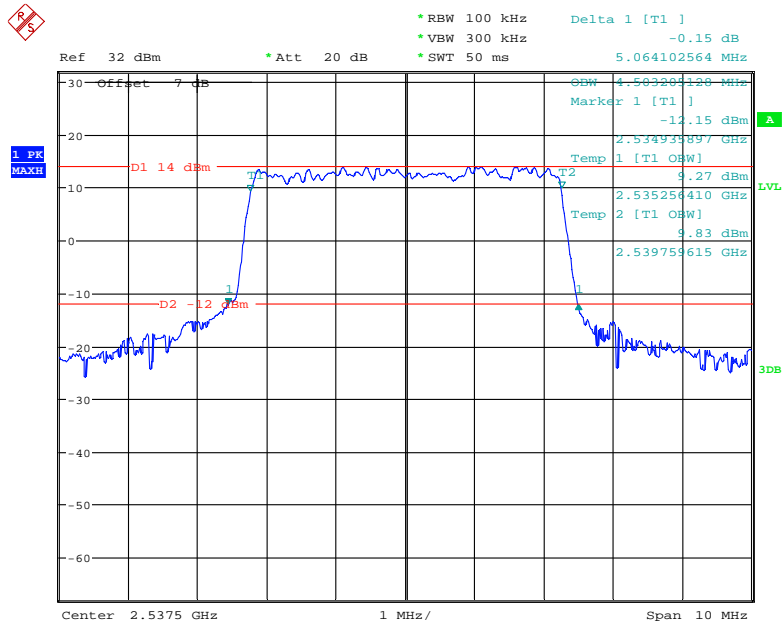

Date: 23.NOV.2020 14:46:23

Band 41_5 MHz_L_QPSK_RB25#0

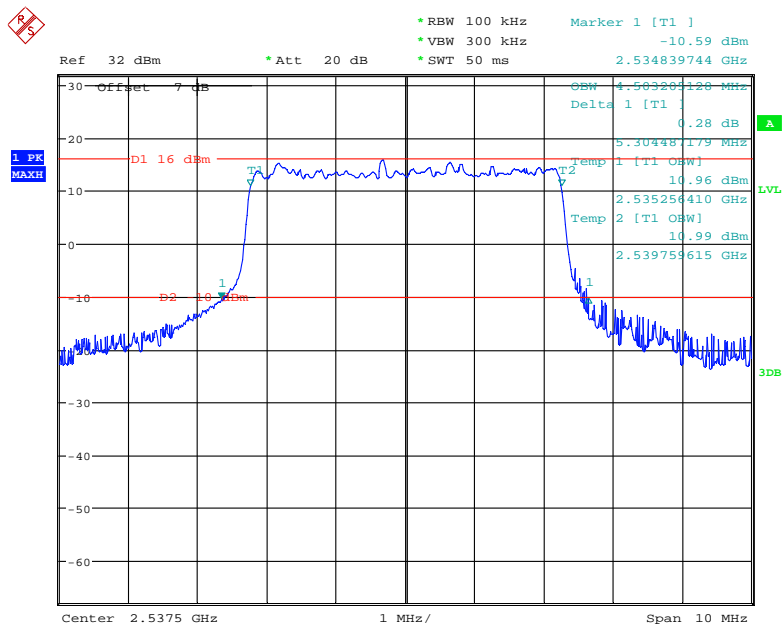

Date: 23.NOV.2020 14:47:45

Band 41_5 MHz_Middle_QPSK_RB25#0

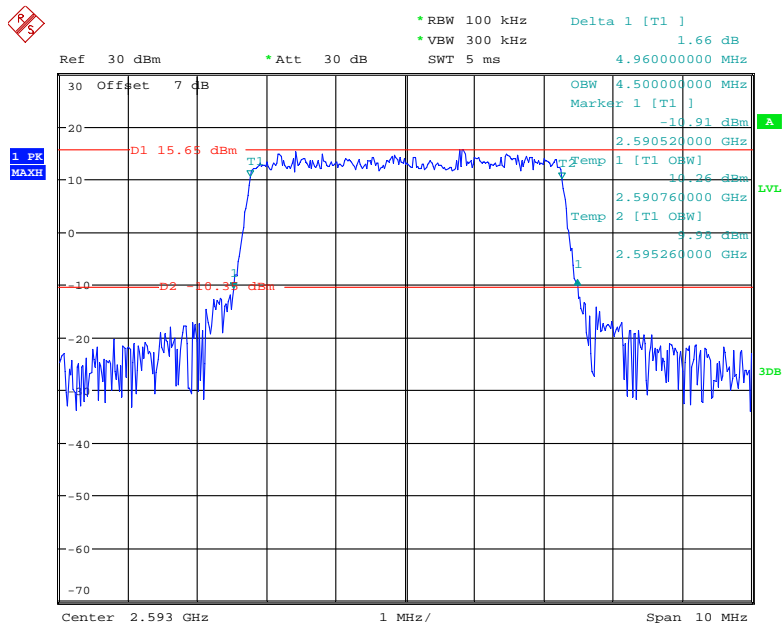

Date: 18.NOV.2020 15:42:09

Band 41_5 MHz_Middle_16QAM_RB25#0

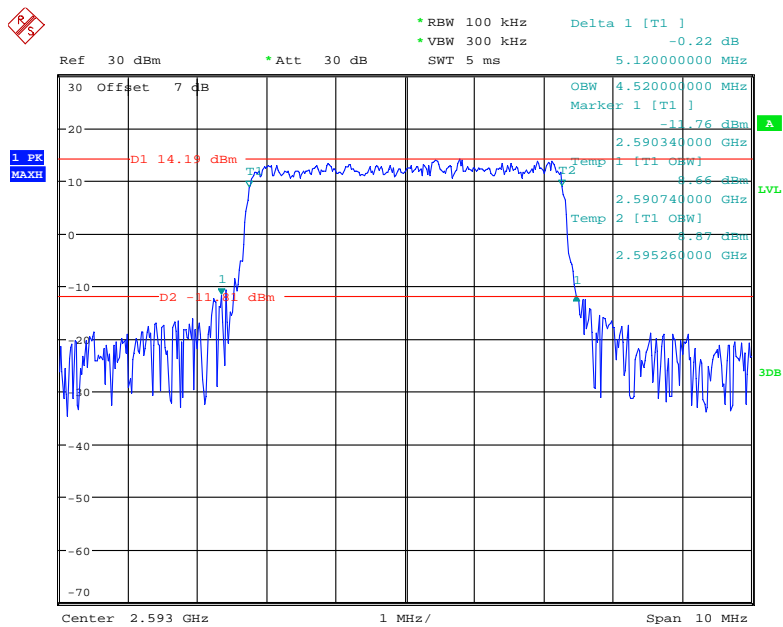

Date: 18.NOV.2020 15:42:41

Band 41_5 MHz_H_16QAM_RB25#0

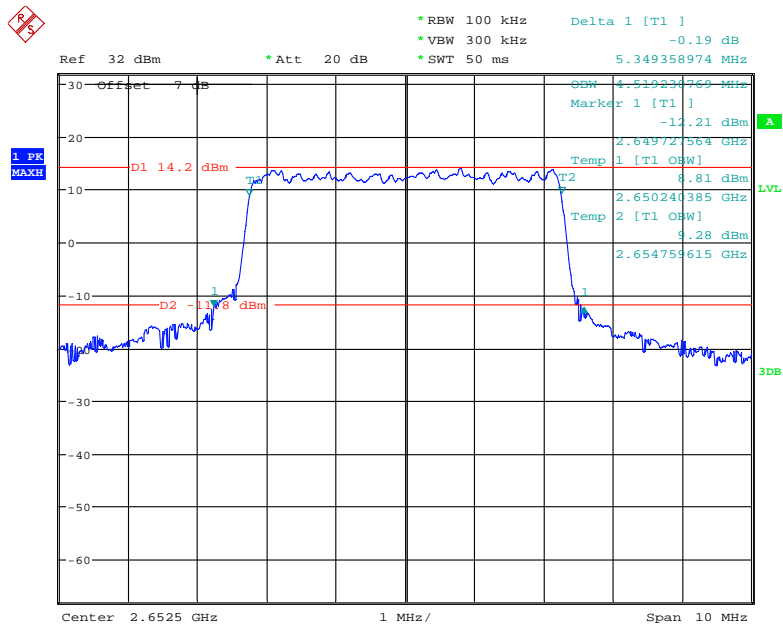

Date: 23.NOV.2020 14:51:00

Band 41_5 MHz_H_QPSK_RB25#0

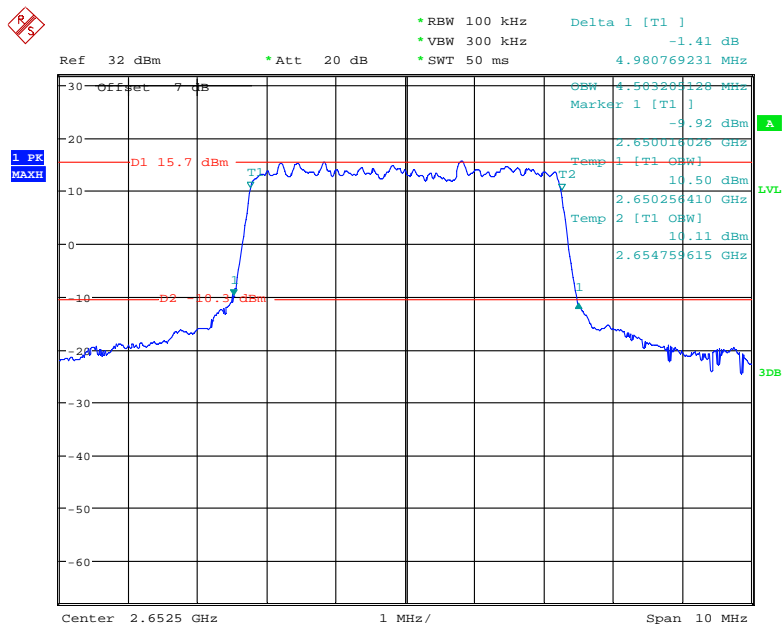

Date: 23.NOV.2020 14:50:02

Band 41_10 MHz_L_16QAM_RB50#0

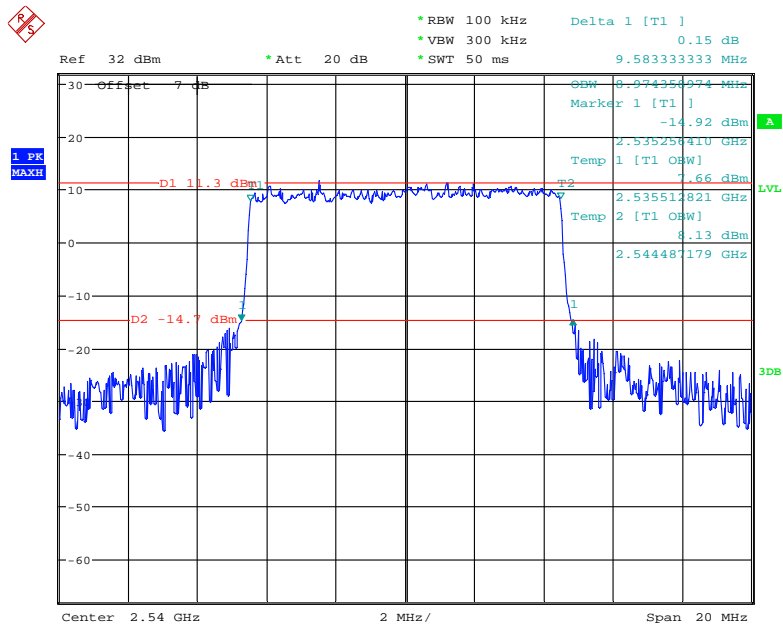

Date: 23.NOV.2020 15:06:20

Band 41_10 MHz_L_QPSK_RB50#0

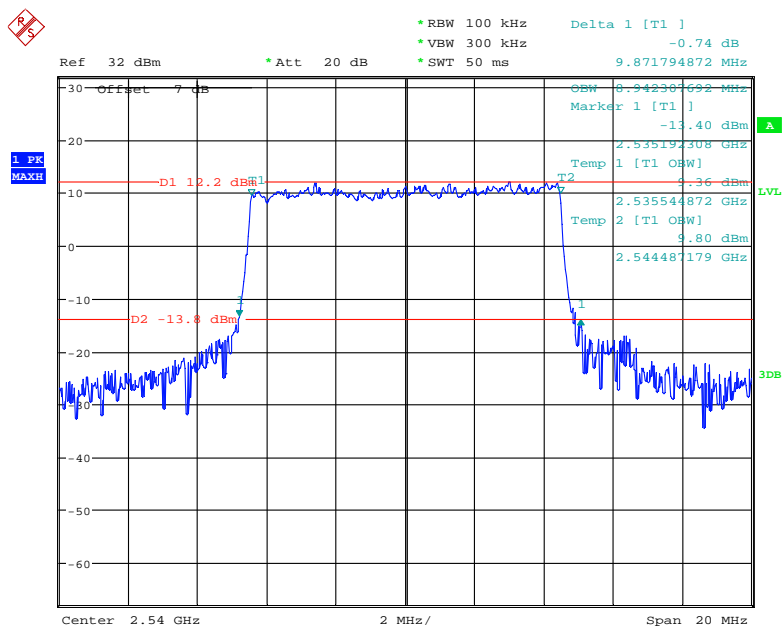

Date: 23.NOV.2020 15:07:40

Band 41_10 MHz_Middle_QPSK_RB50#0

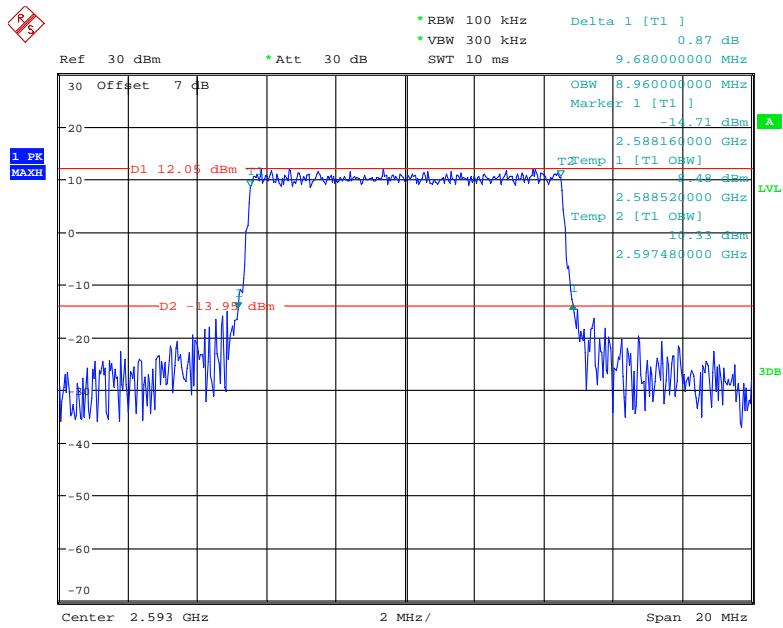

Date: 18.NOV.2020 15:43:11

Band 41_10 MHz_Middle_16QAM_RB50#0

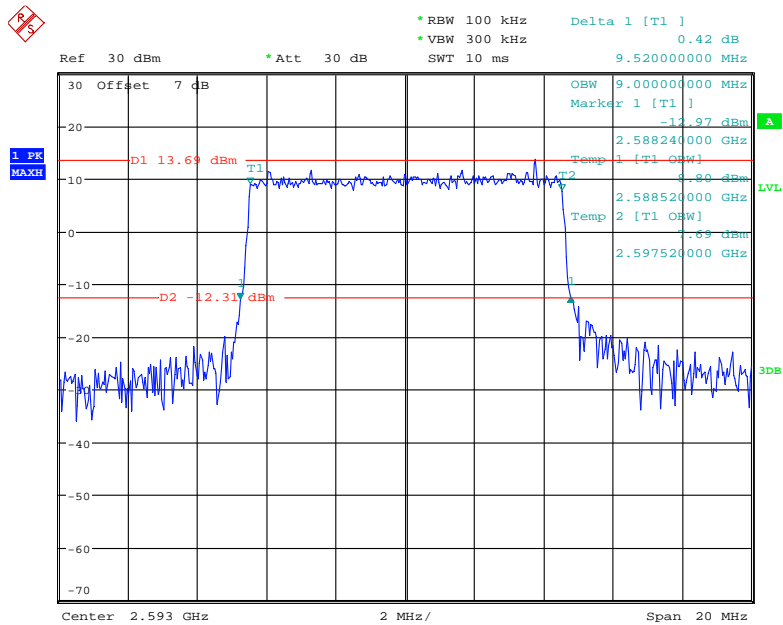

Date: 18.NOV.2020 15:43:46

Band 41_10 MHz_H_16QAM_RB50#0

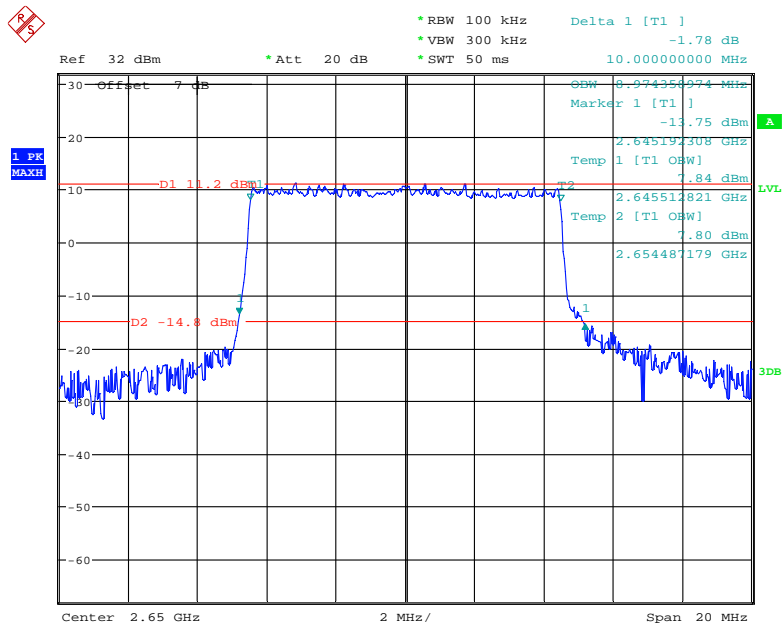

Date: 23.NOV.2020 15:09:36

Band 41_10 MHz_H_QPSK_RB50#0

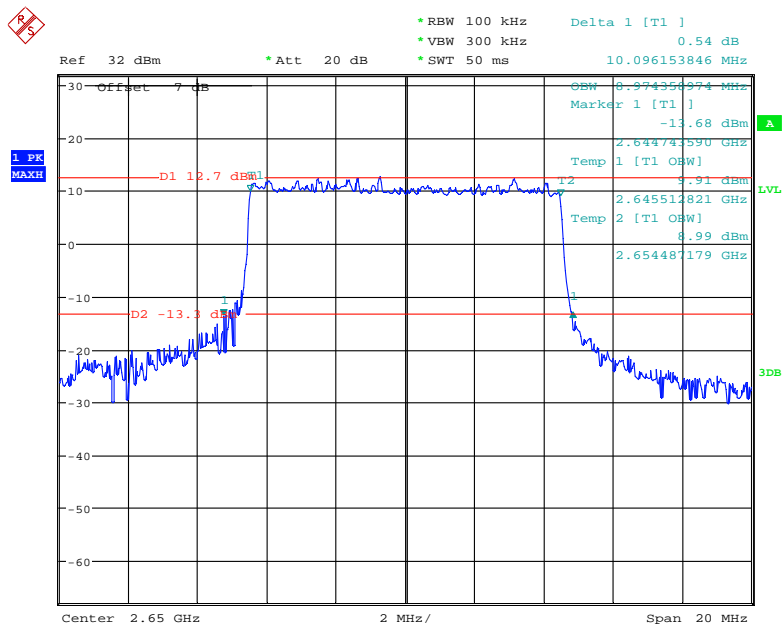

Date: 23.NOV.2020 15:08:46

Band 41_15 MHz_L_16QAM_RB75#0

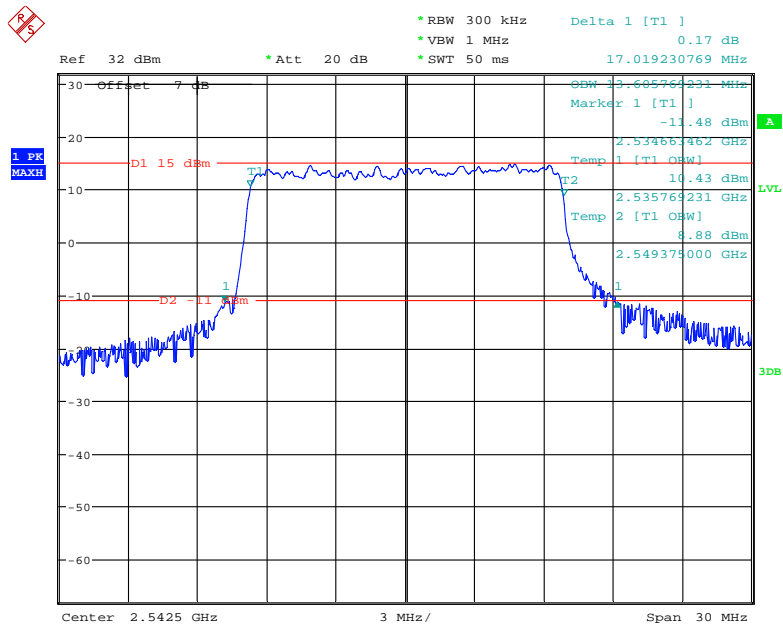

Date: 23.NOV.2020 15:16:16

Band 41_15 MHz_L_QPSK_RB75#0

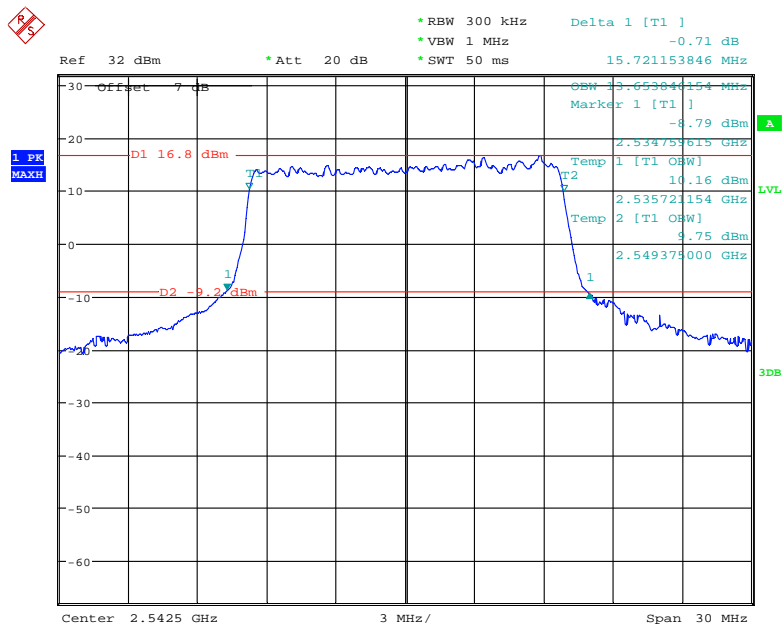

Date: 23.NOV.2020 15:20:00

Band 41_15 MHz_Middle_QPSK_RB75#0

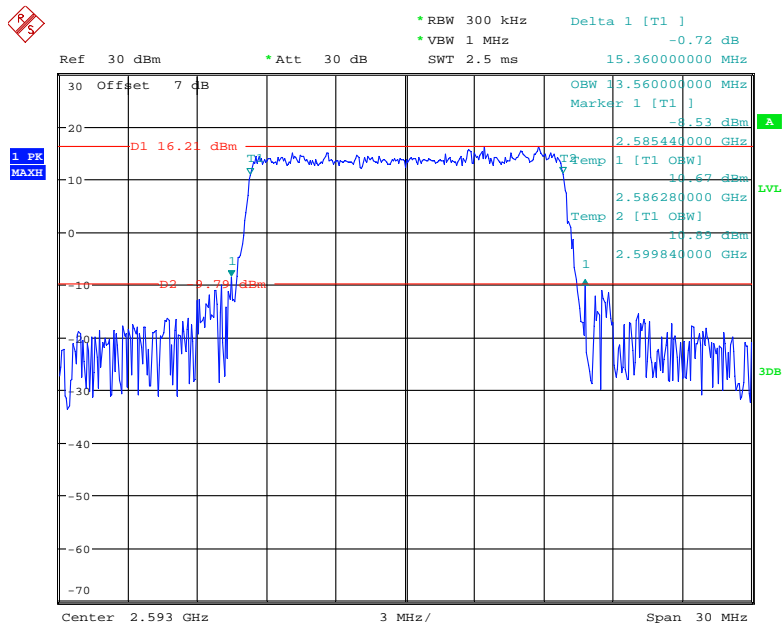

Date: 18.NOV.2020 15:44:26

Band 41_15 MHz_Middle_16QAM_RB75#0

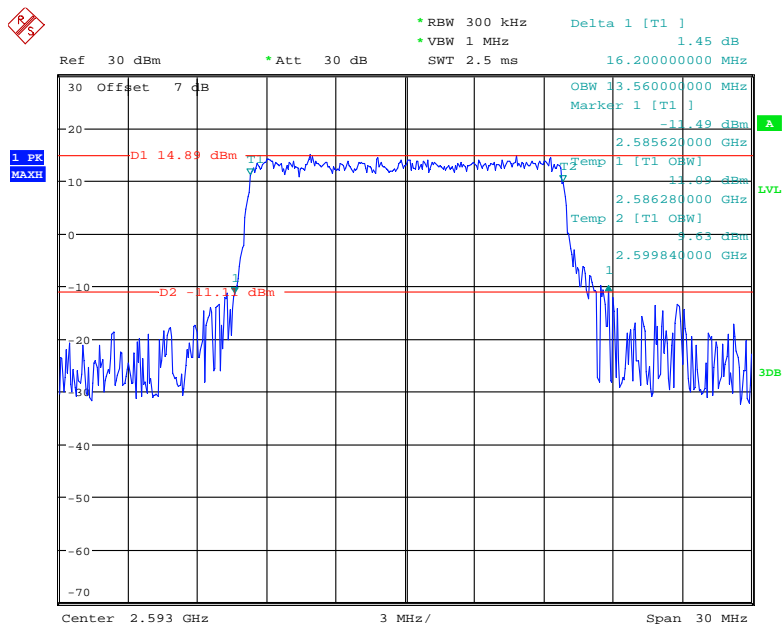

Date: 18.NOV.2020 15:45:04

Band 41_15 MHz_H_16QAM_RB75#0

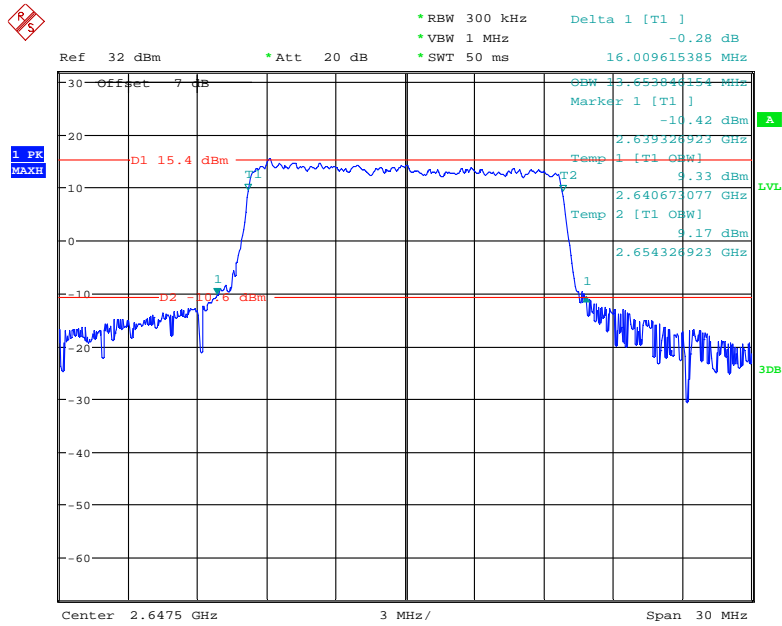

Date: 23.NOV.2020 15:22:51

Band 41_15 MHz_H_QPSK_RB75#0

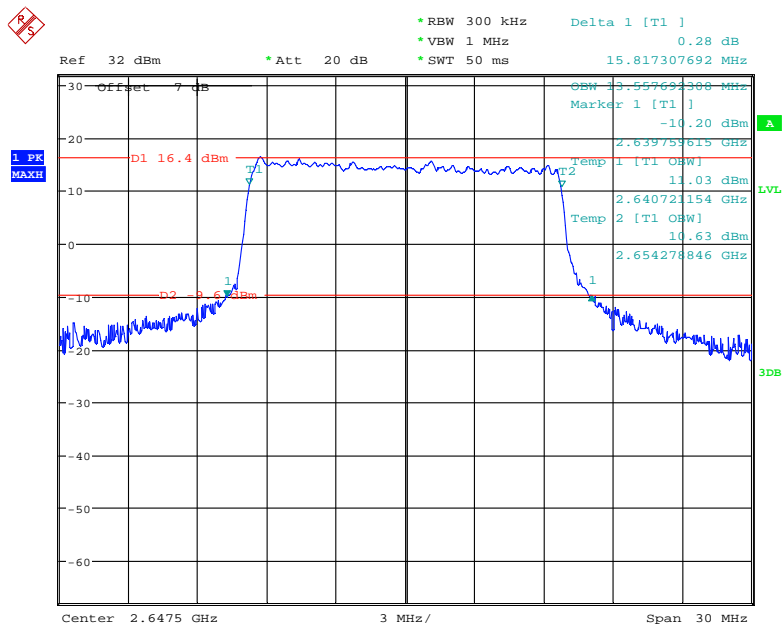

Date: 23.NOV.2020 15:21:52

Band 41_20 MHz_L_16QAM_RB100#0

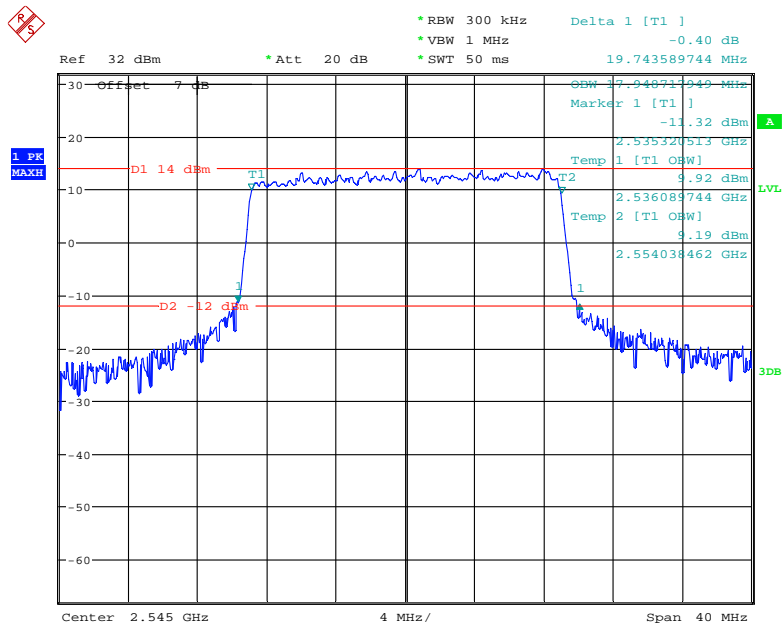

Date: 23.NOV.2020 15:34:10

Band 41_20 MHz_L_QPSK_RB100#0

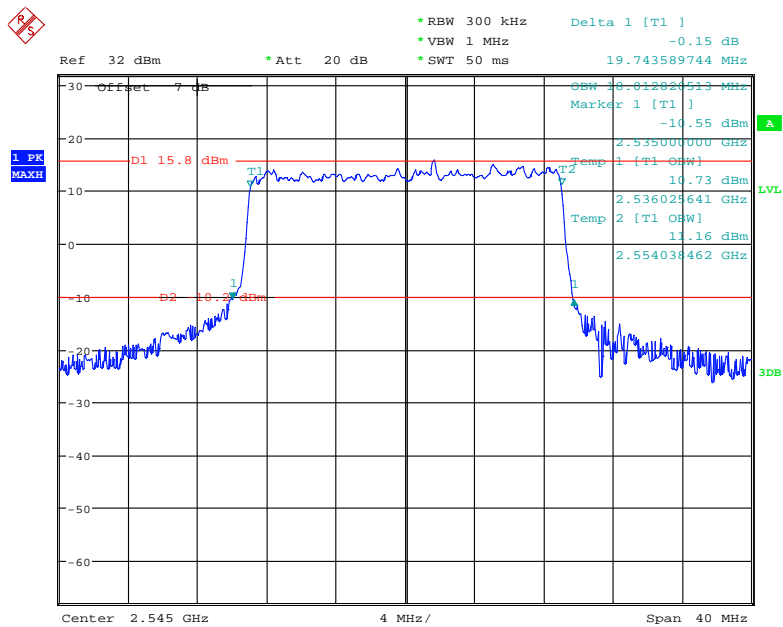

Date: 23.NOV.2020 15:33:23

Band 41_20 MHz_Middle_QPSK_RB100#0

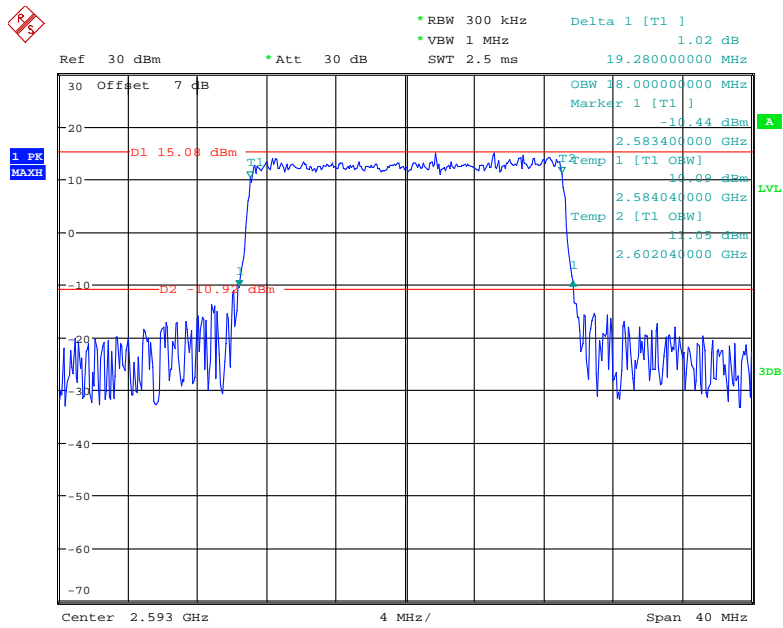

Date: 18.NOV.2020 15:45:44

Band 41_20 MHz_Middle_16QAM_RB100#0

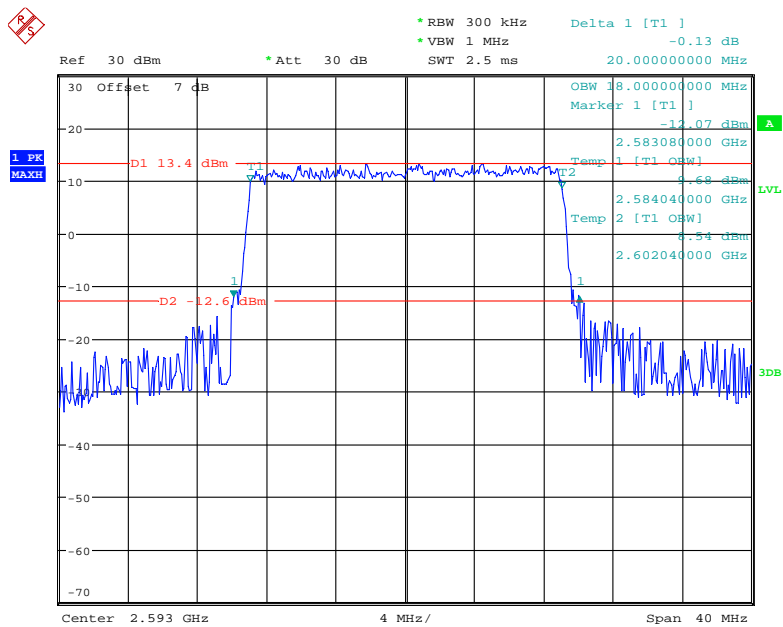

Date: 18.NOV.2020 15:46:15

Band 41_20 MHz_H_16QAM_RB100#0

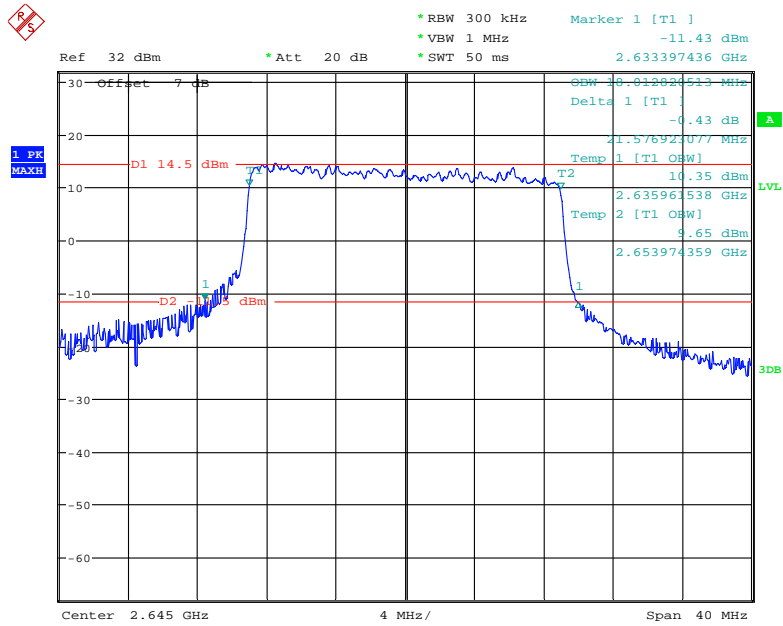

Date: 23.NOV.2020 15:35:25

Band 41_20 MHz_H_QPSK_RB100#0

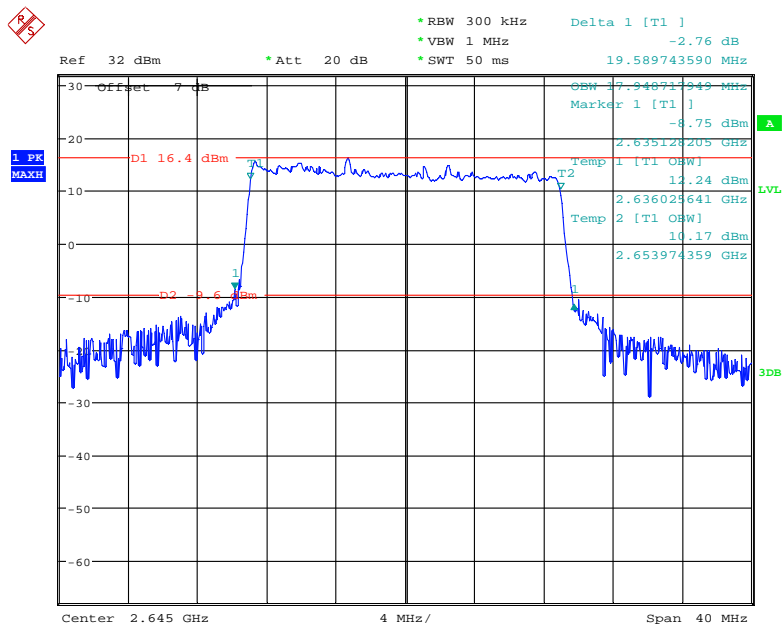

Date: 23.NOV.2020 15:36:04

FCC §2.1051, §22.917(a) & §24.238(a); §27.53 - SPURIOUS EMISSIONS AT ANTENNA TERMINALS

Applicable Standard

FCC §2.1051, §22.917(a) and §24.238(a) and §27.53.

The spectrum was to be investigated to the tenth harmonics of the highest fundamental frequency as specified in § 2.1051.

Test Procedure

The RF output of the transceiver was connected to a spectrum analyzer and simulator through appropriate attenuation. The resolution bandwidth of the spectrum analyzer was set at 1MHz. Sufficient scans were taken to show any out of band emissions up to 10th harmonic.

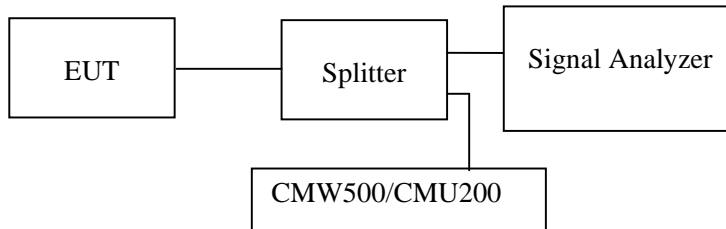

Test Data

Environmental Conditions

Temperature:	25 °C
Relative Humidity:	55 %
ATM Pressure:	101.0 kPa

The testing was performed by Coco Liu from 2020-11-09 to 2020-12-02.

EUT operation mode: Transmitting

Test result: Pass

Pre-scan with Low, Middle and High channel, the worst case is middle channel as below:

Please refer to the following plots.

Cellular Band (Part 22H)

30 MHz – 1 GHz (GSM Mode)

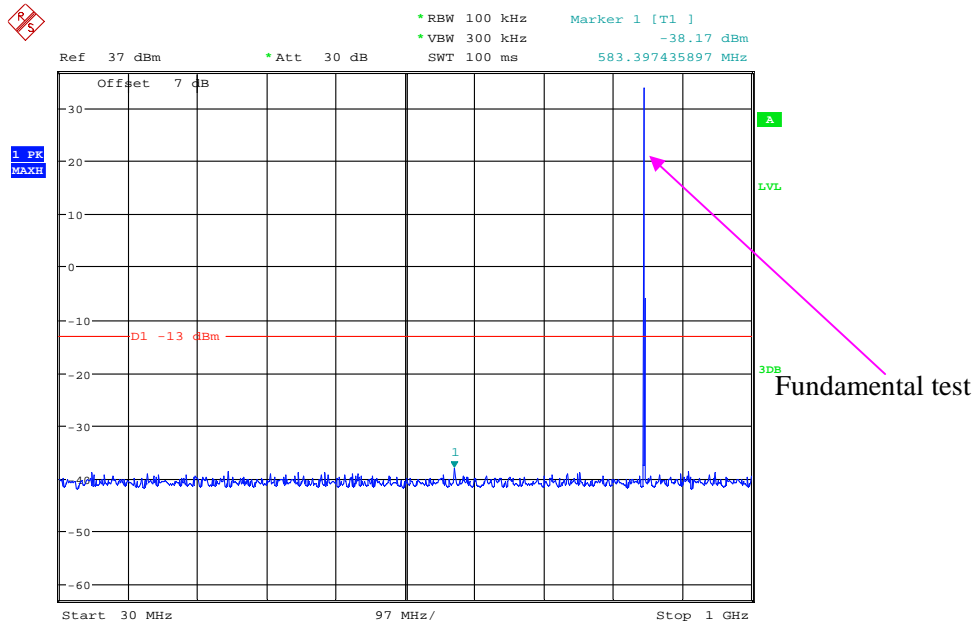

Date: 9.NOV.2020 11:04:17

1 GHz – 10 GHz (GSM Mode)

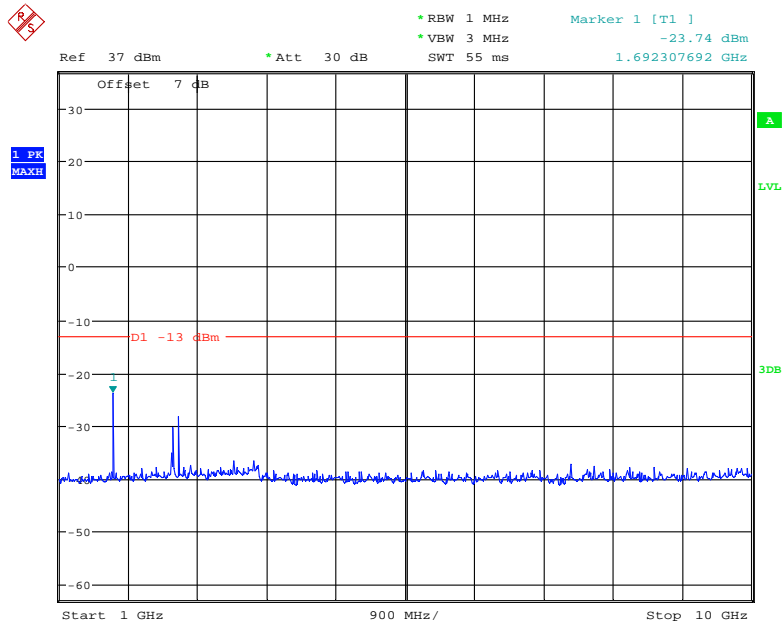

Date: 9.NOV.2020 11:03:03

30 MHz – 1 GHz (WCDMA Mode)

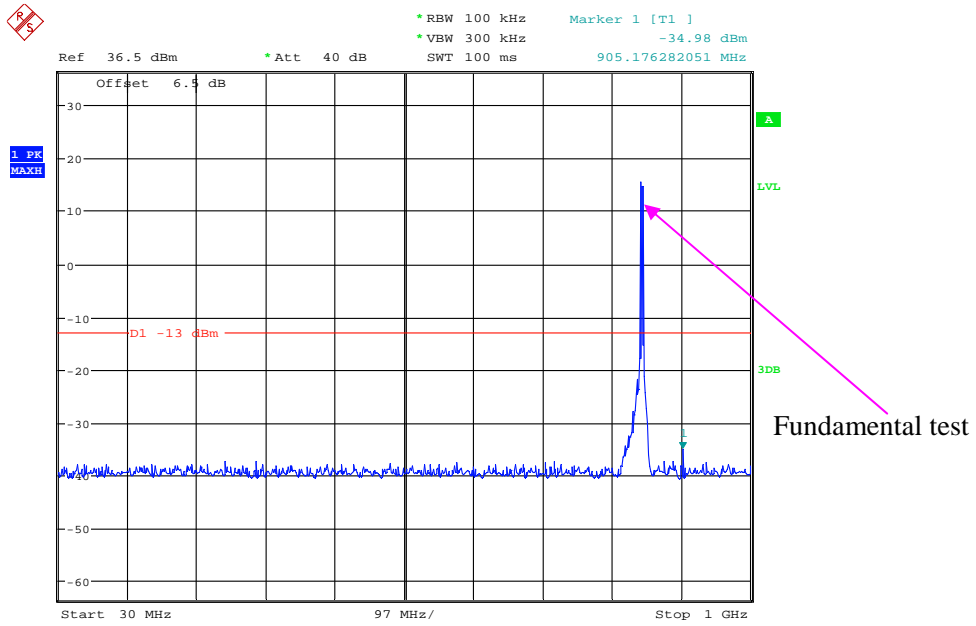

Date: 17.NOV.2020 15:33:43

1 GHz – 10 GHz (WCDMA Mode)

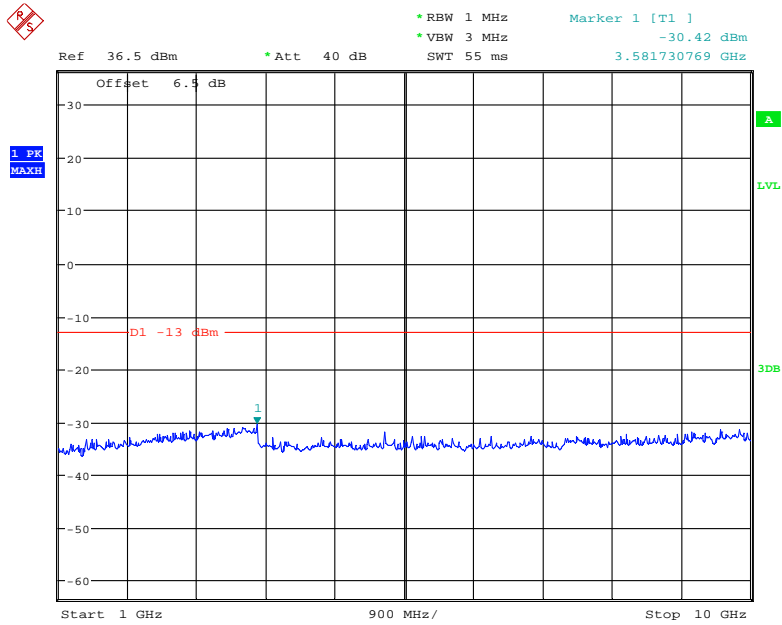

Date: 17.NOV.2020 15:32:55

PCS Band (Part 24E)

30 MHz – 1 GHz (GSM Mode)

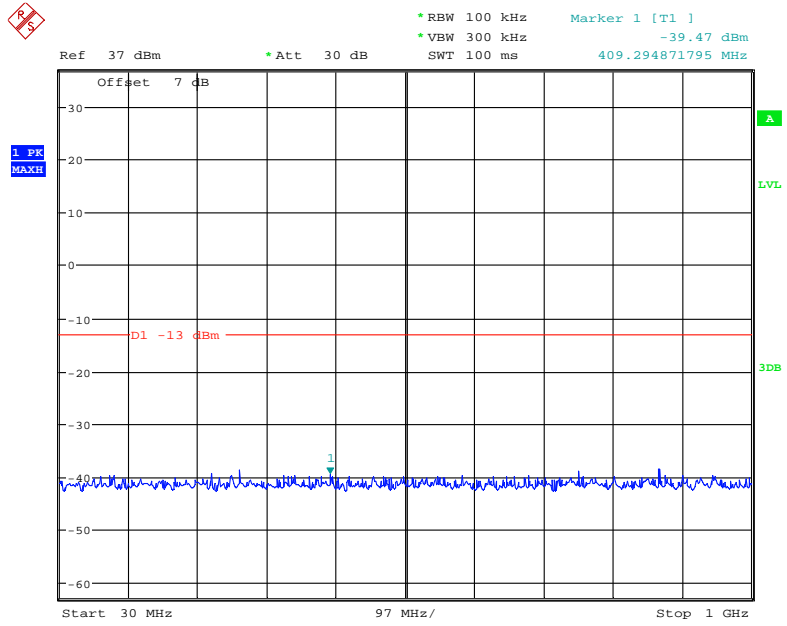

Date: 9.NOV.2020 12:02:57

1 GHz – 20 GHz (GSM Mode)

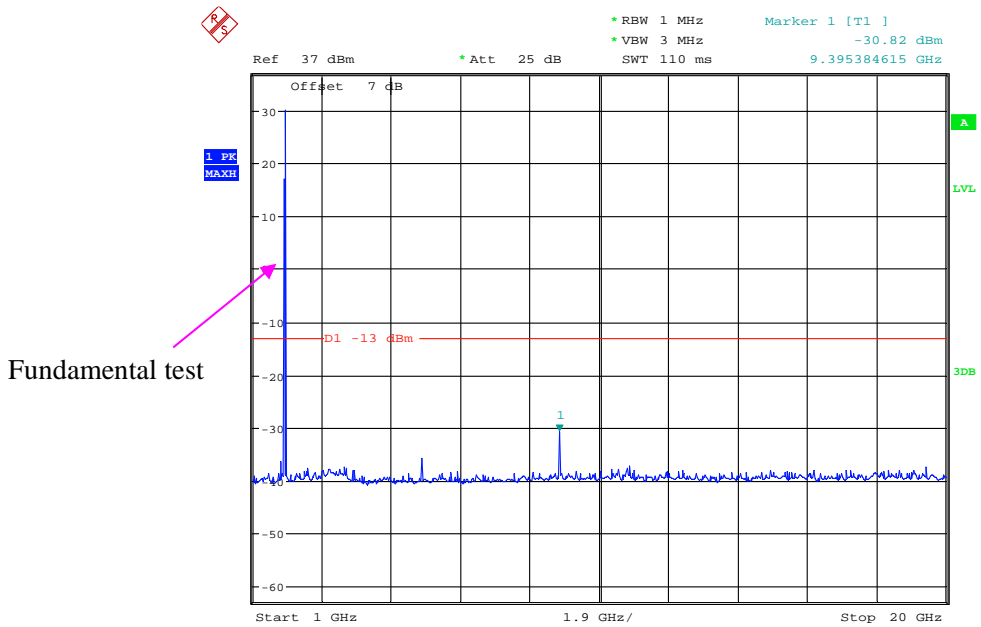

Date: 2.DEC.2020 10:26:51

30 MHz – 1 GHz (WCDMA Mode)

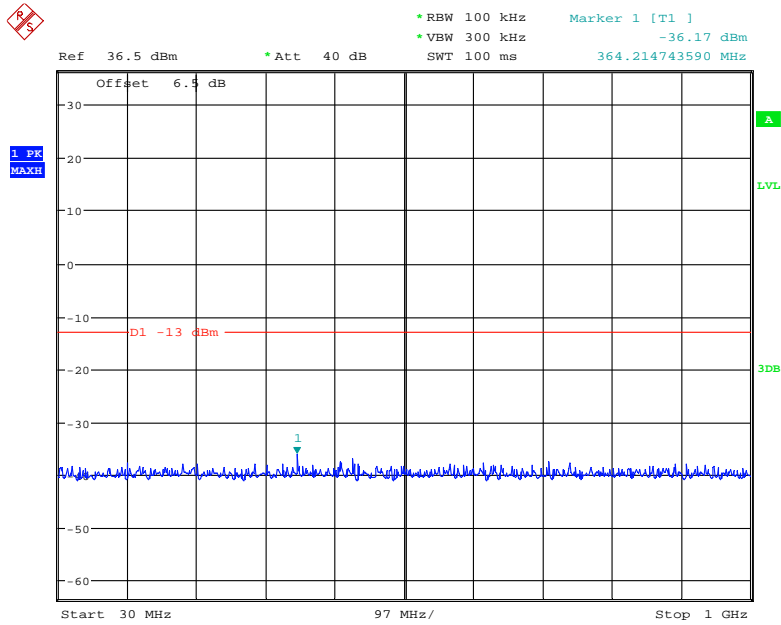

Date: 17.NOV.2020 16:04:41

1 GHz – 20 GHz (WCDMA Mode)

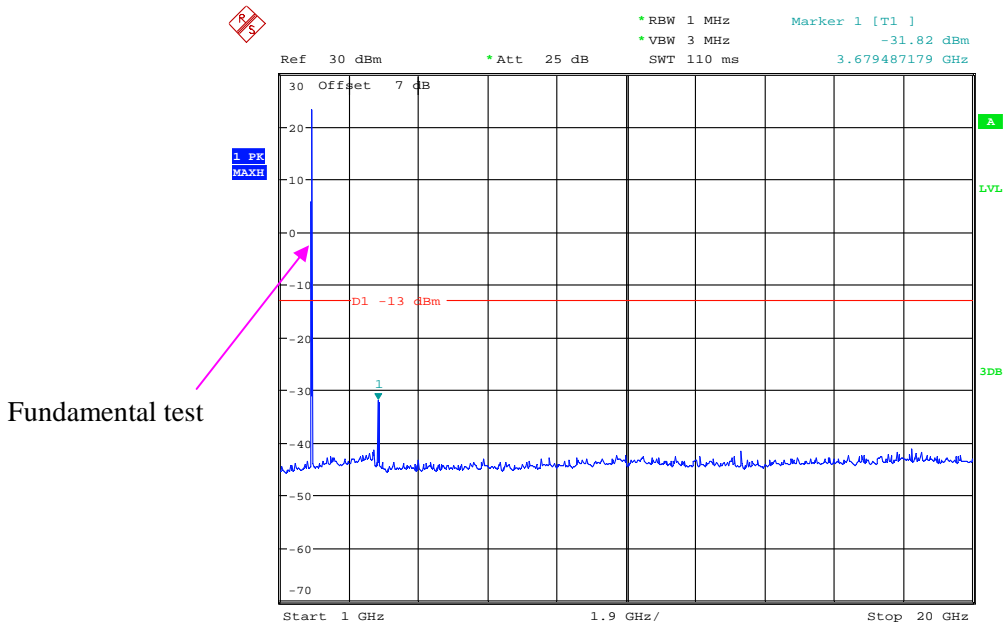

Date: 30.NOV.2020 15:20:11

AWS Band (Part 27)

30 MHz – 1 GHz (WCDMA Mode)

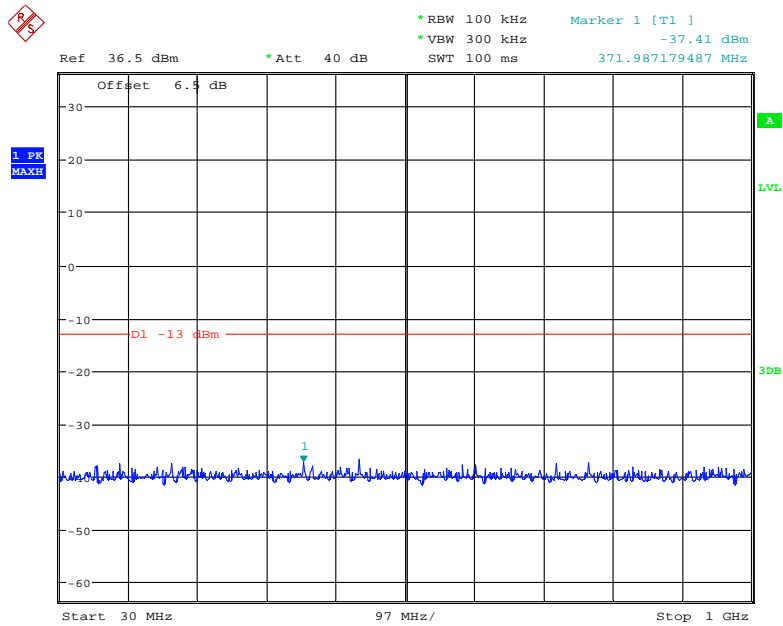

Date: 17.NOV.2020 15:51:24

1 GHz – 20 GHz (WCDMA Mode)

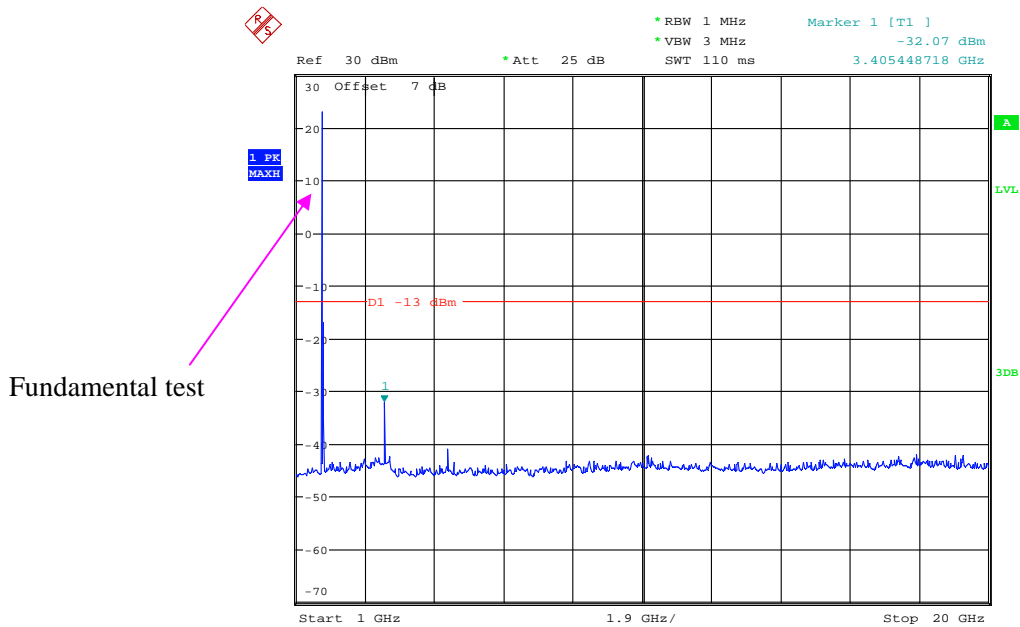

Date: 30.NOV.2020 15:27:49

LTE Band 2:

30 MHz - 1 GHz (1.4 MHz, Middle channel)

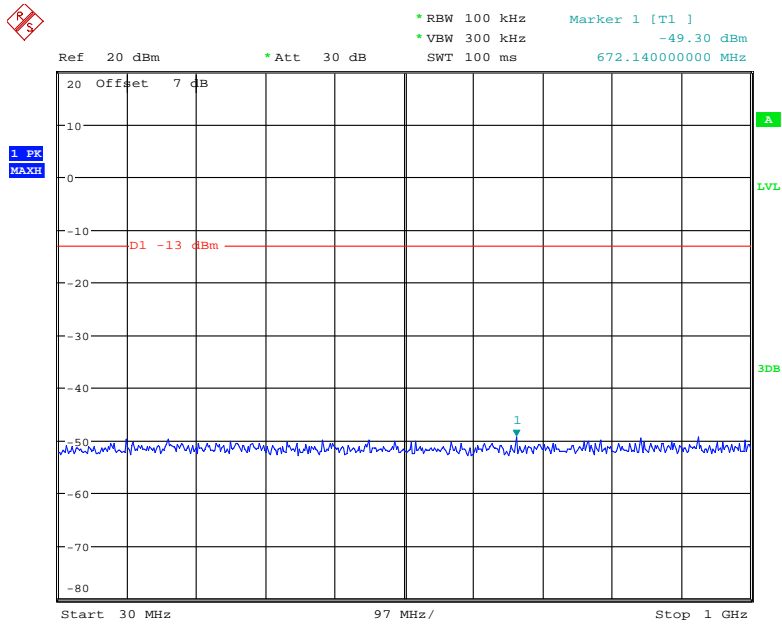

Date: 18.NOV.2020 15:22:37

1 GHz - 20 GHz (1.4 MHz, Middle channel)

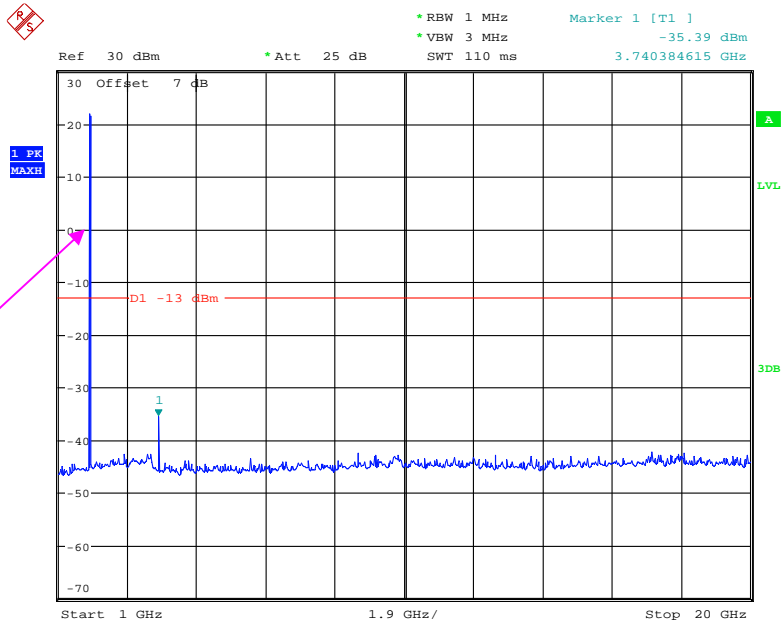

Fundamental test

Date: 30.NOV.2020 15:33:54

30 MHz - 1 GHz (3.0 MHz, Middle channel)

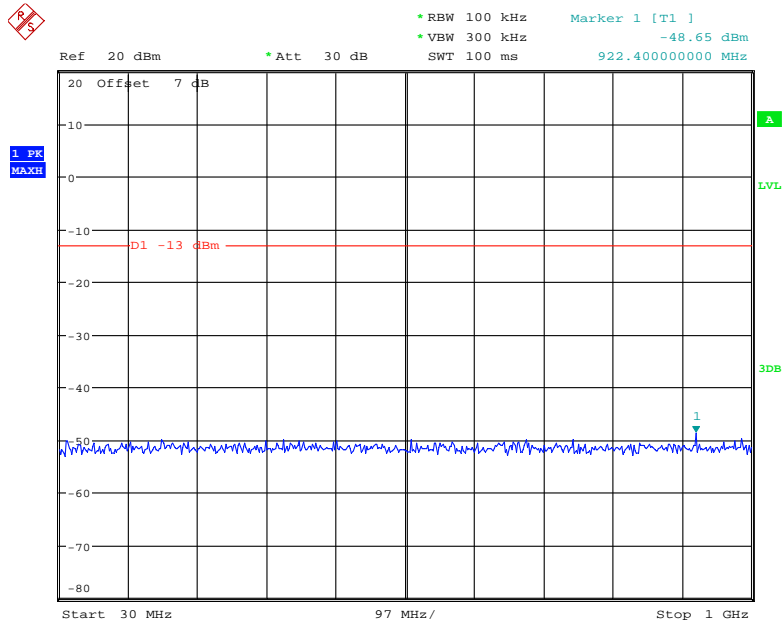

Date: 18.NOV.2020 15:23:06

1 GHz - 20 GHz (3.0 MHz, Middle channel)

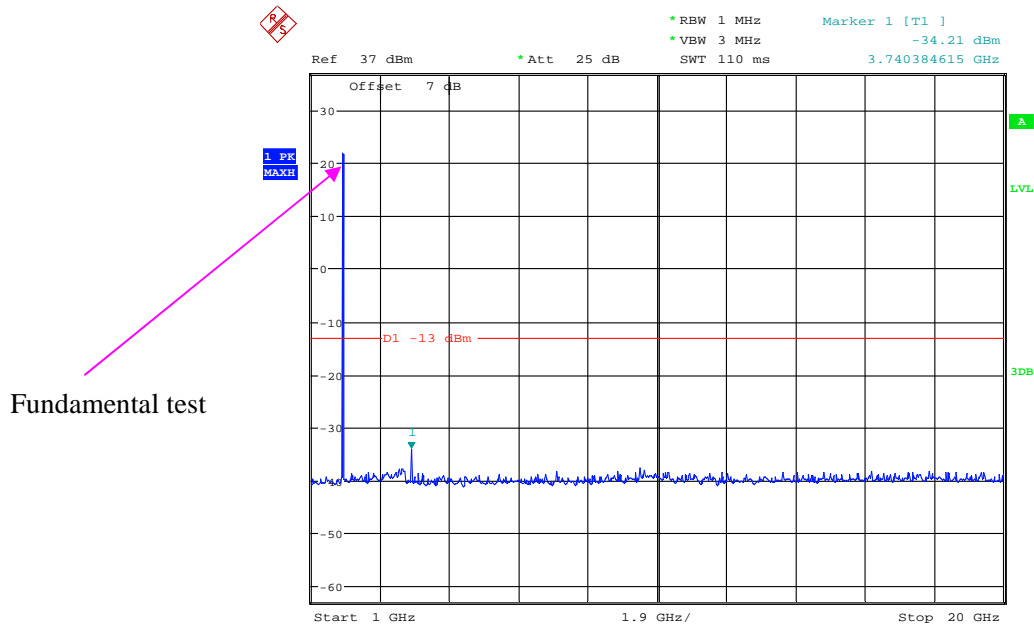

Fundamental test

Date: 30.NOV.2020 15:34:39

30 MHz - 1 GHz (5.0 MHz, Middle channel)

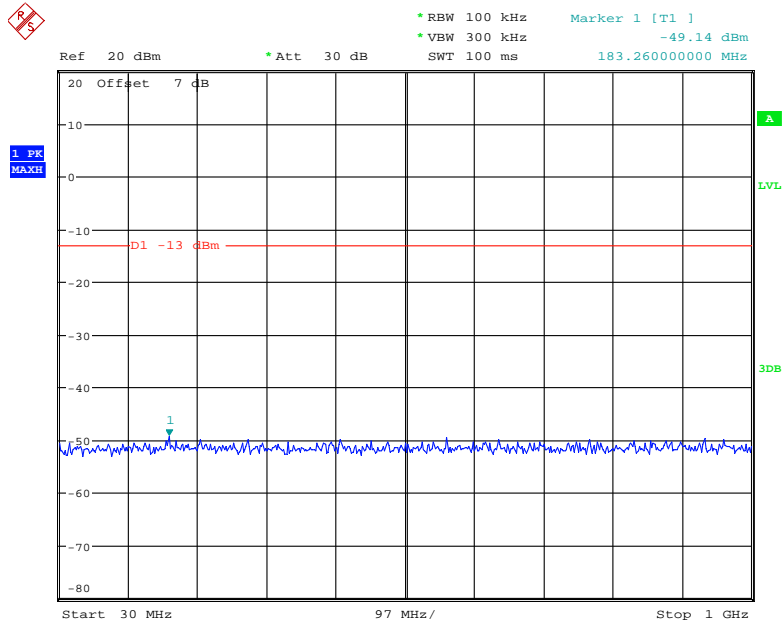

Date: 18.NOV.2020 15:23:37

1 GHz - 20 GHz (5.0 MHz, Middle channel)

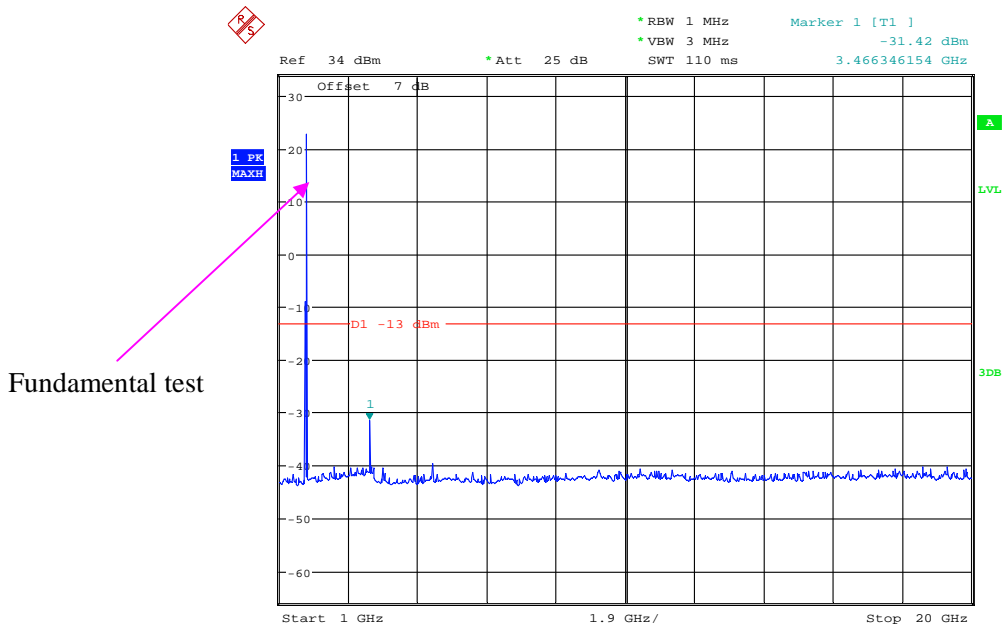

Date: 30.NOV.2020 15:36:43

30 MHz - 1 GHz (10.0 MHz, Middle channel)

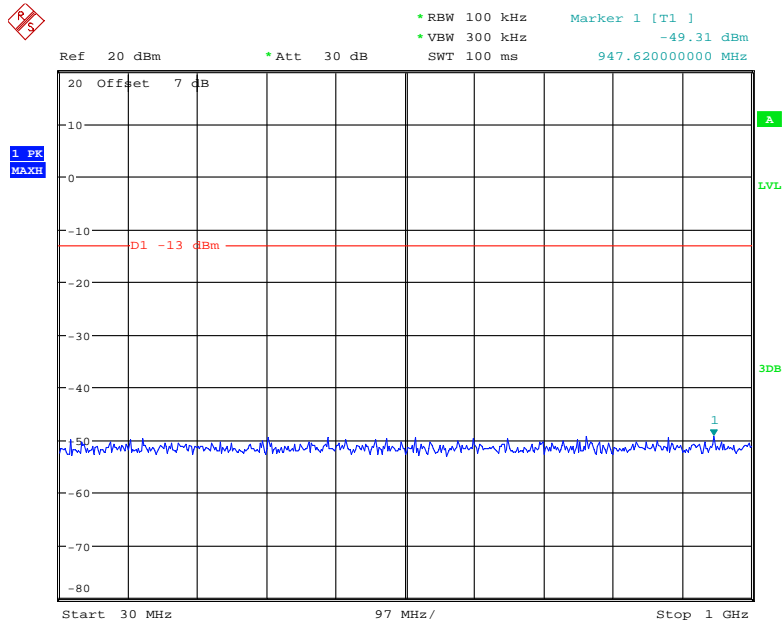

Date: 18.NOV.2020 15:24:08

1 GHz - 20 GHz (10.0 MHz, Middle channel)

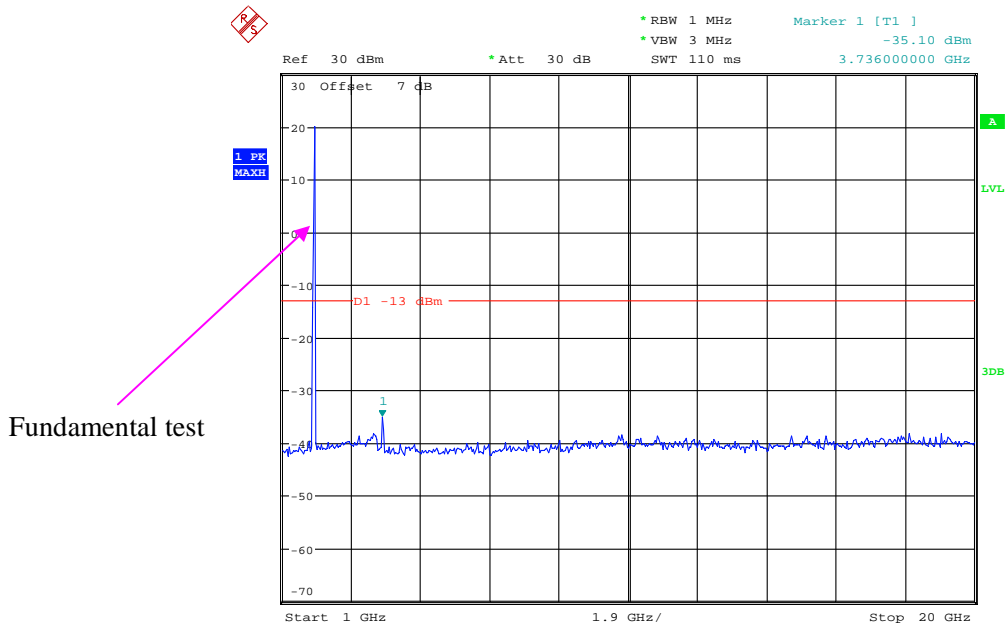

Date: 18.NOV.2020 15:24:20

30 MHz - 1 GHz (15.0 MHz, Middle channel)

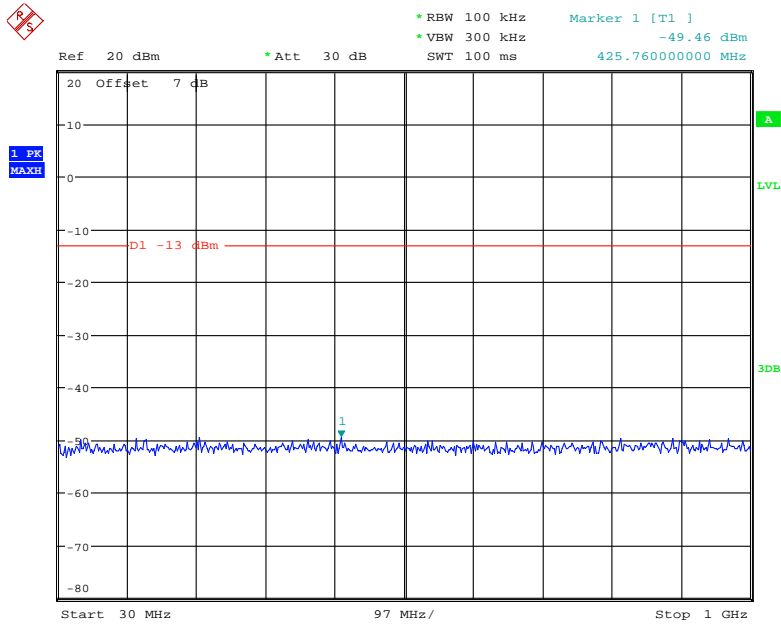

Date: 18.NOV.2020 15:24:43

1 GHz - 20 GHz (15.0 MHz, Middle channel)

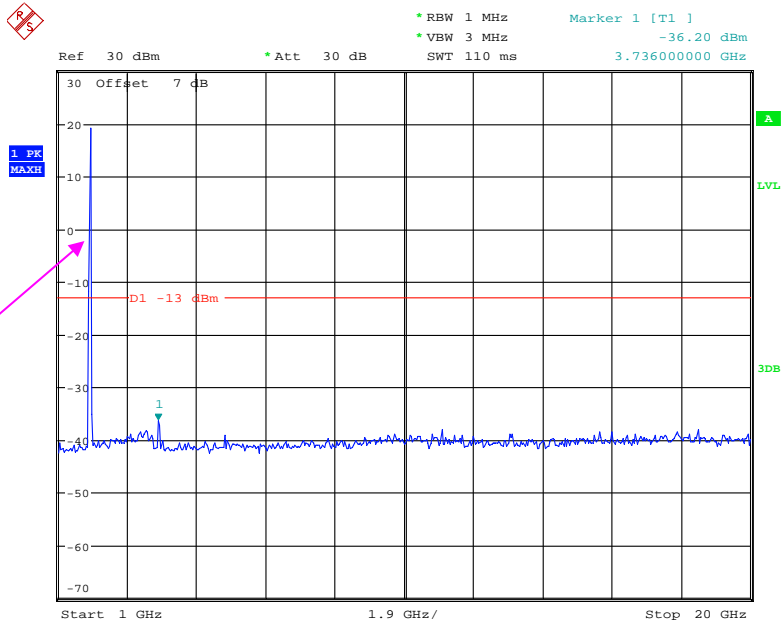

Fundamental test

Date: 18.NOV.2020 15:24:54

30 MHz - 1 GHz (20.0 MHz, Middle channel)

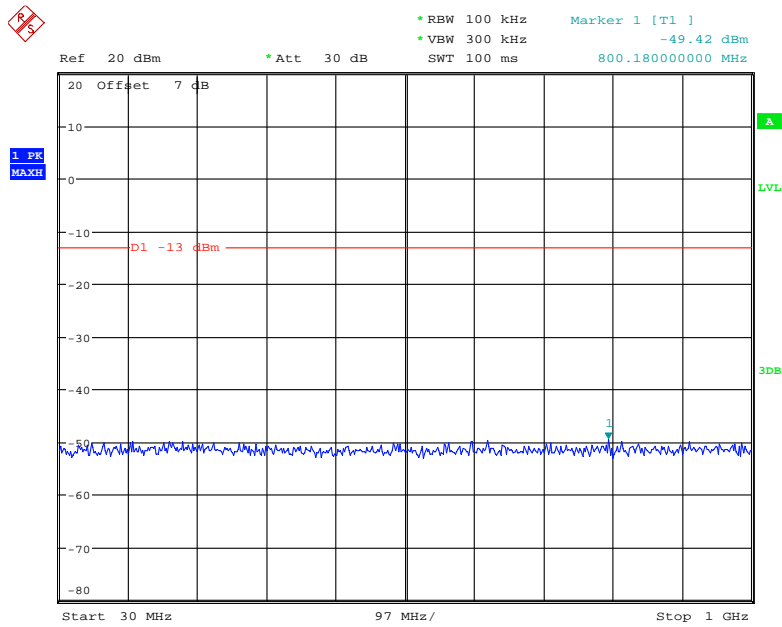

Date: 18.NOV.2020 15:25:17

1 GHz - 2 GHz (20.0 MHz, Middle channel)

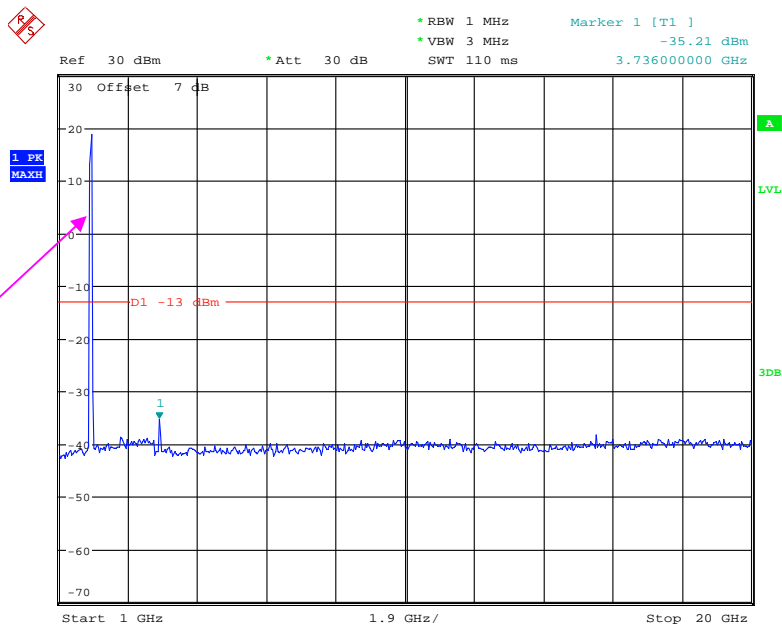

Fundamental test

Date: 18.NOV.2020 15:25:29

LTE Band 4:

30 MHz - 1 GHz (1.4 MHz, Middle channel)

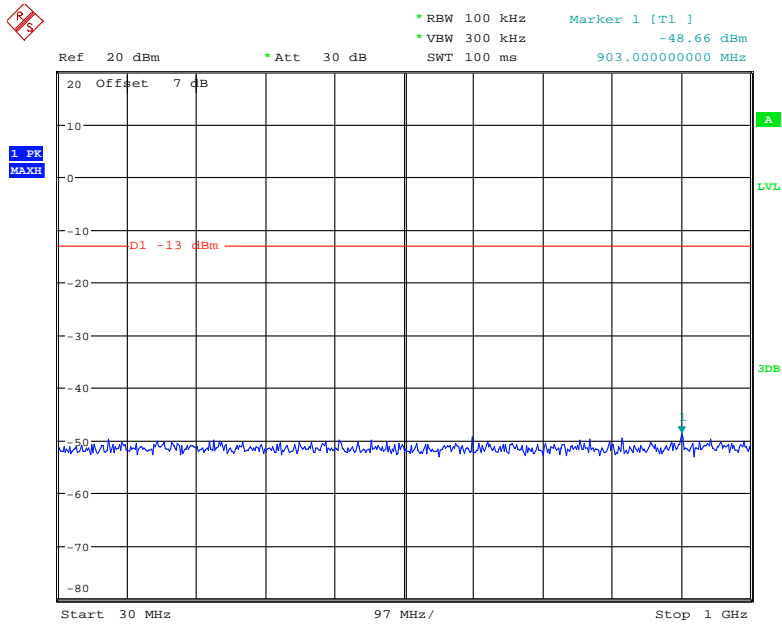

Date: 18.NOV.2020 15:25:47

1 GHz - 20 GHz (1.4 MHz, Middle channel)

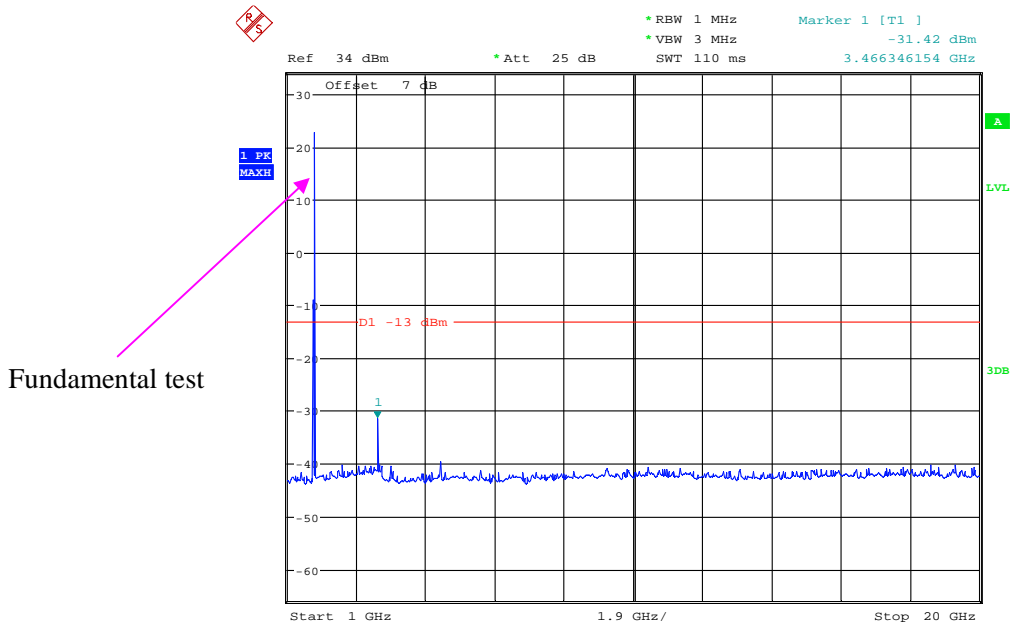

Date: 30.NOV.2020 15:36:43

30 MHz - 1 GHz (3.0 MHz, Middle channel)

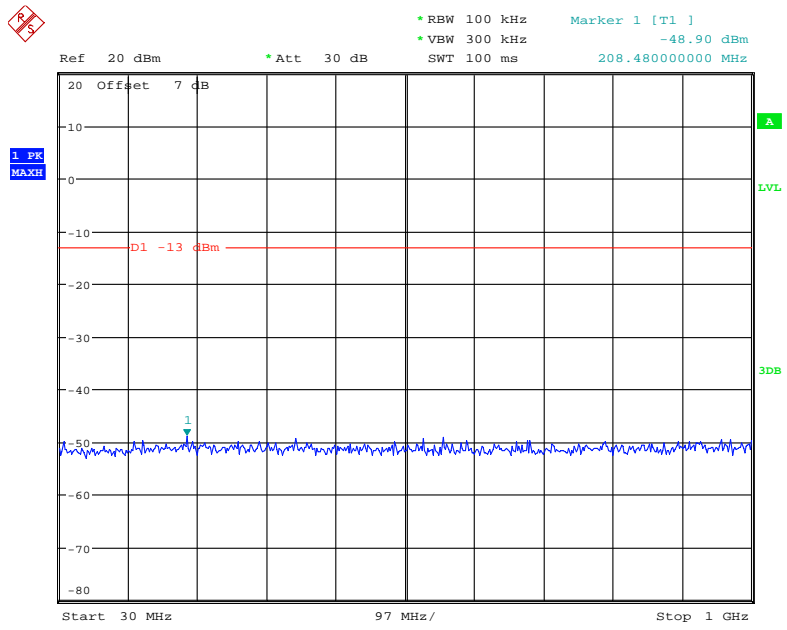

Date: 18.NOV.2020 15:26:20

1 GHz - 20 GHz (3.0 MHz, Middle channel)

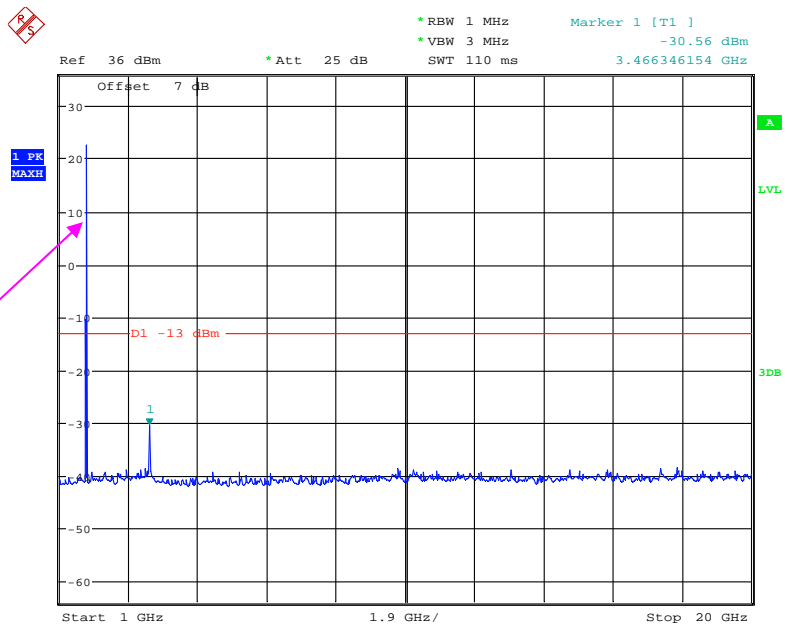

Fundamental test

Date: 30.NOV.2020 15:37:21

30 MHz - 1 GHz (5.0 MHz, Middle channel)

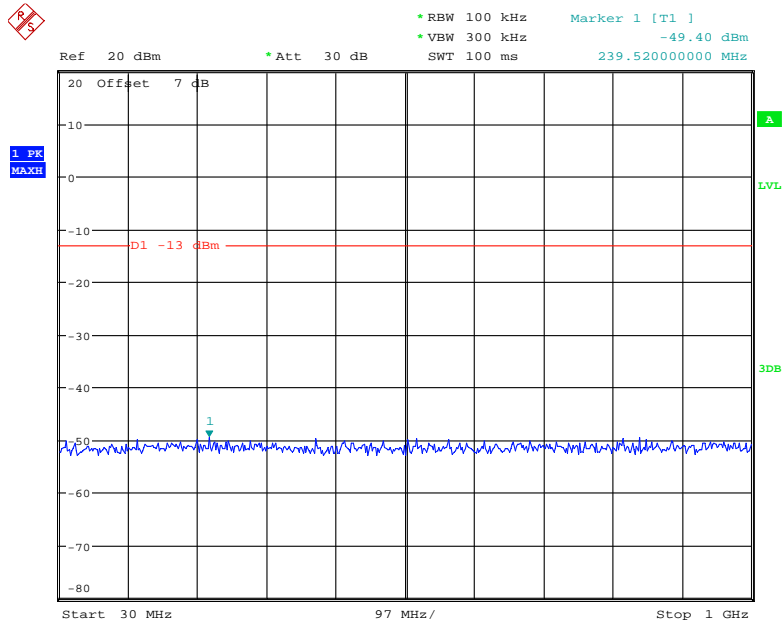

Date: 18.NOV.2020 15:26:51

1 GHz - 20 GHz (5.0 MHz, Middle channel)

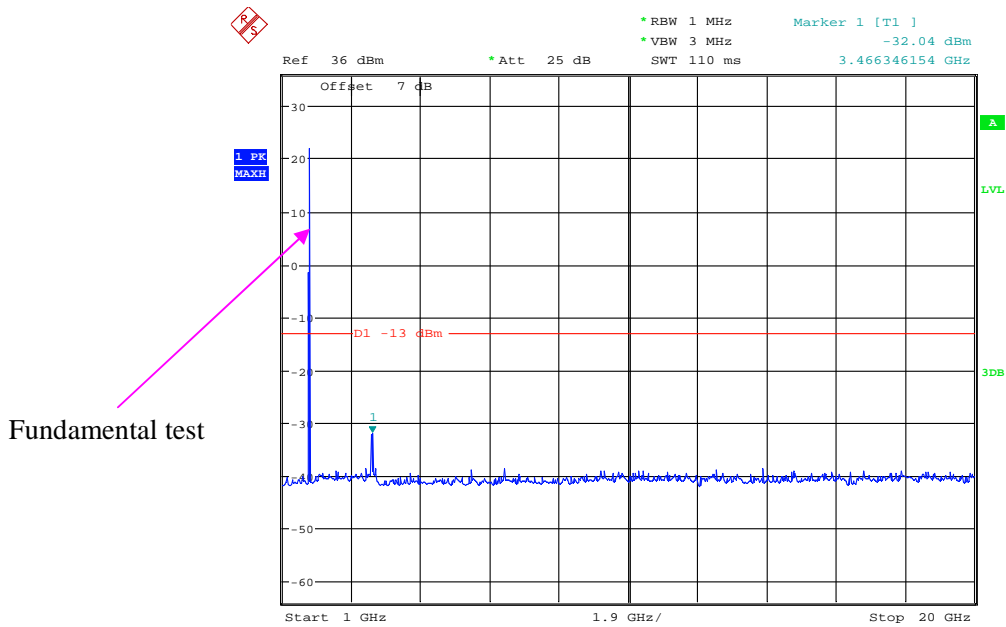

Date: 30.NOV.2020 15:37:53

30 MHz - 1 GHz (10.0 MHz, Middle channel)

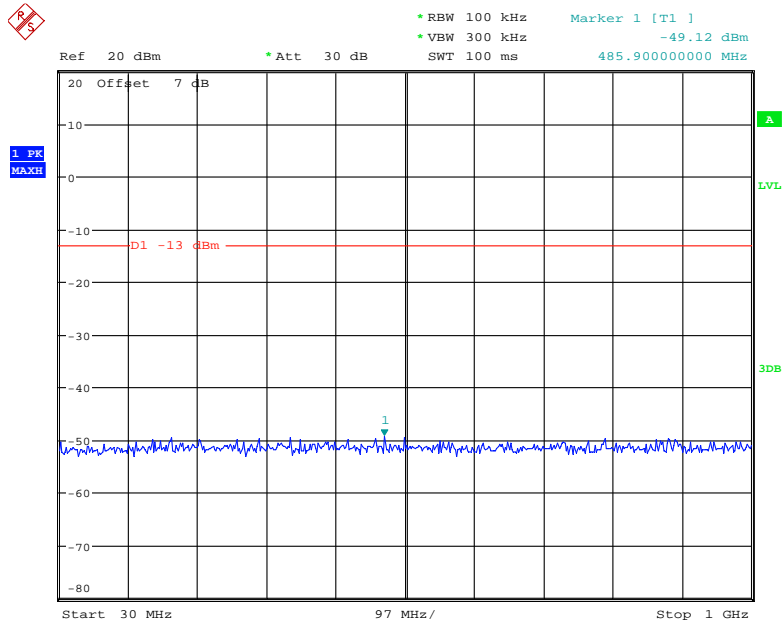

Date: 18.NOV.2020 15:27:22

1 GHz - 20 GHz (10.0 MHz, Middle channel)

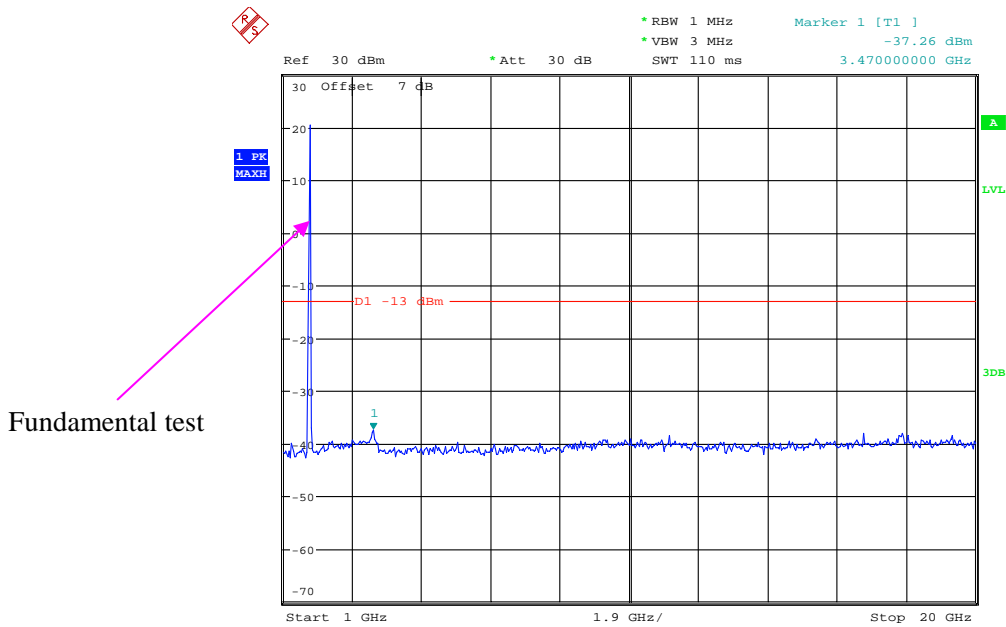

Date: 18.NOV.2020 15:27:33

30 MHz - 1 GHz (15.0 MHz, Middle channel)

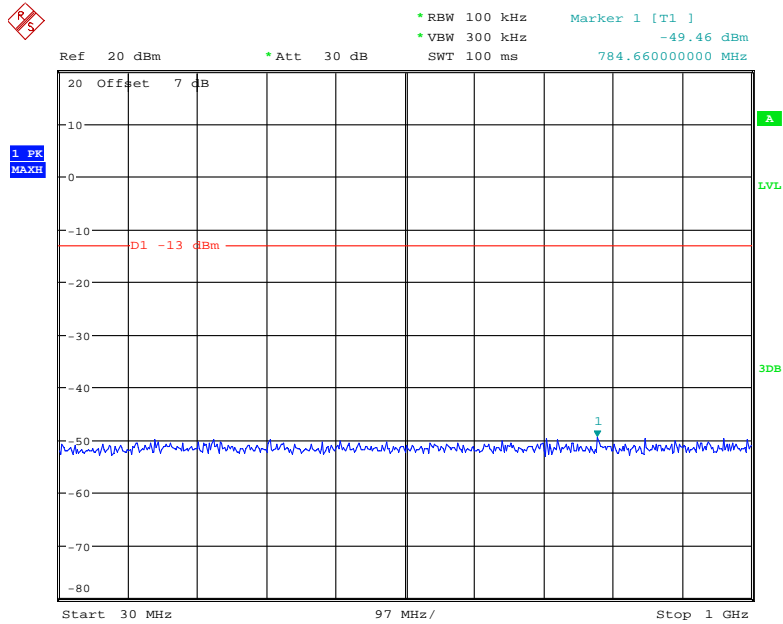

Date: 18.NOV.2020 15:27:56

1 GHz - 20 GHz (15.0 MHz, Middle channel)

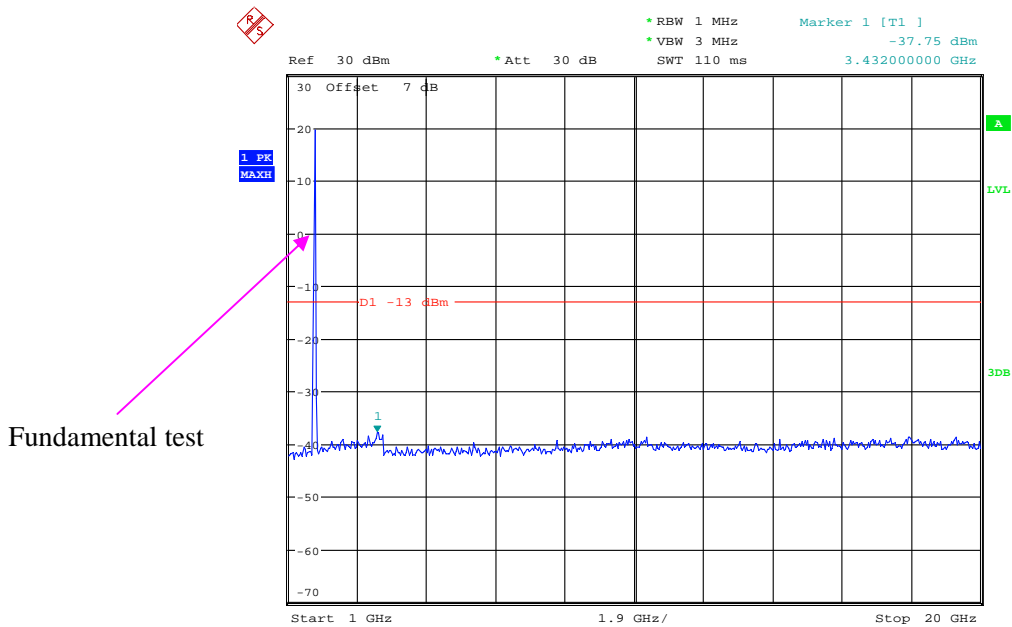

Date: 18.NOV.2020 15:28:07

30 MHz - 1 GHz (20.0 MHz, Middle channel)

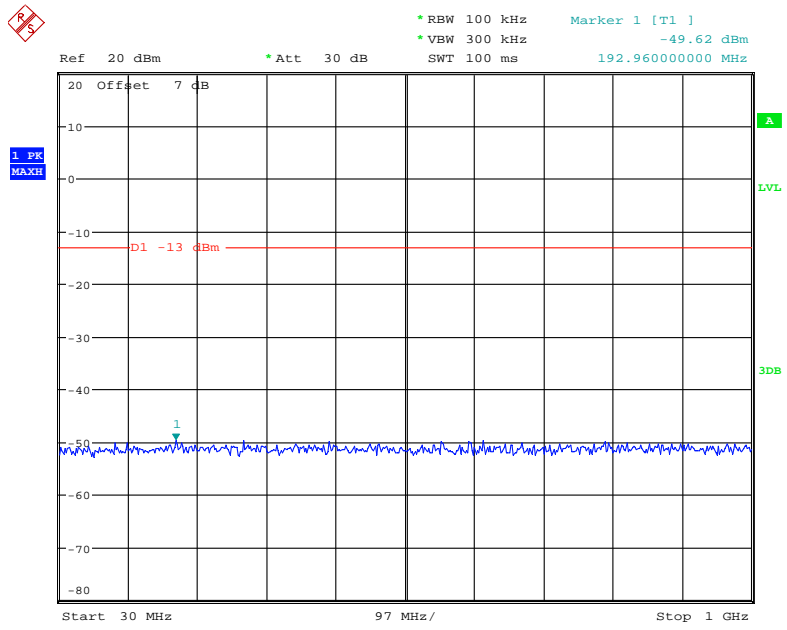

Date: 18.NOV.2020 15:28:33

1 GHz - 20 GHz (20.0 MHz, Middle channel)

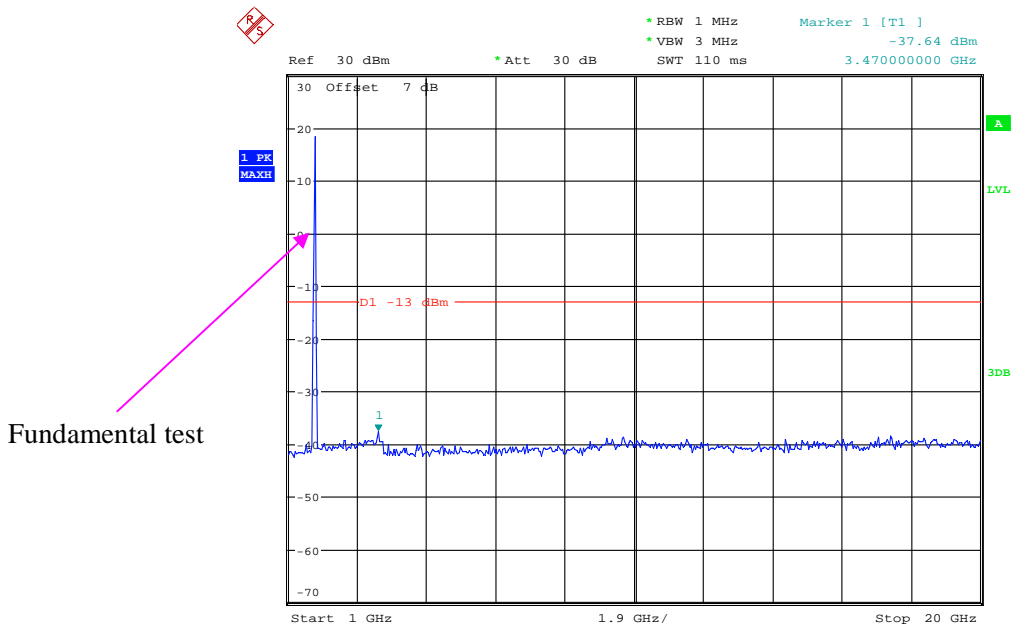

Date: 18.NOV.2020 15:28:45

LTE Band 5:

30 MHz - 1 GHz (1.4 MHz, Middle channel)

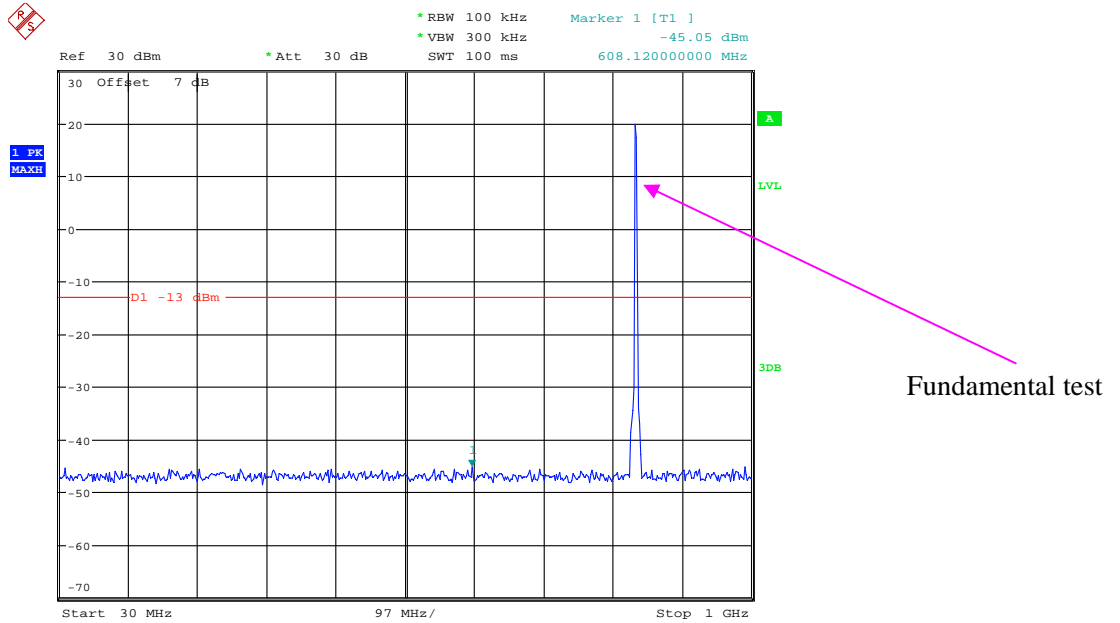

Date: 18.NOV.2020 15:29:03

1 GHz - 10 GHz (1.4 MHz, Middle channel)

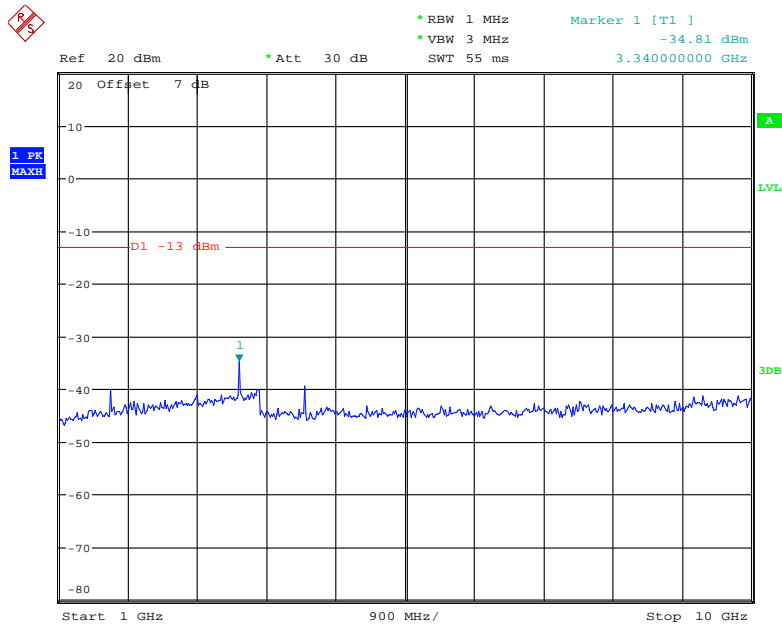

Date: 18.NOV.2020 15:29:14

30 MHz - 1 GHz (3.0 MHz, Middle channel)

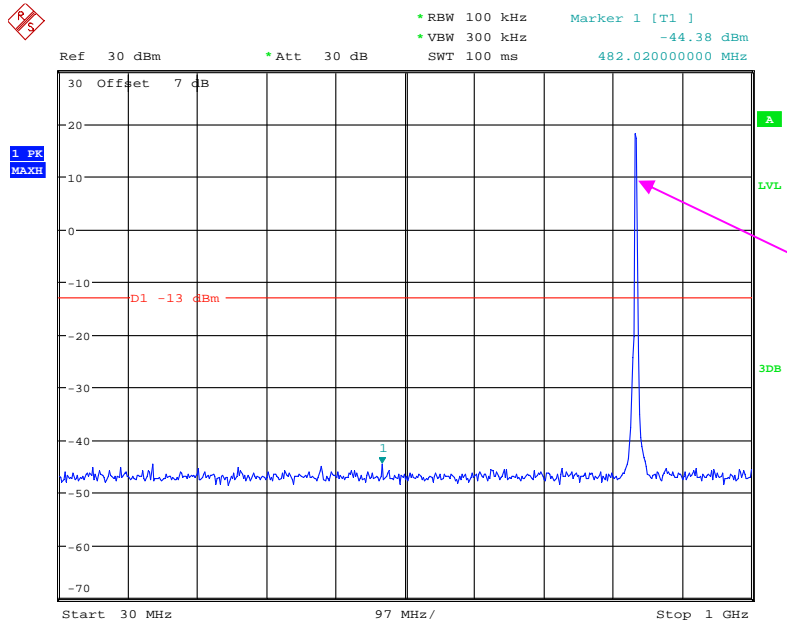

Fundamental test

Date: 18.NOV.2020 15:29:32

1 GHz - 10 GHz (3.0 MHz, Middle channel)

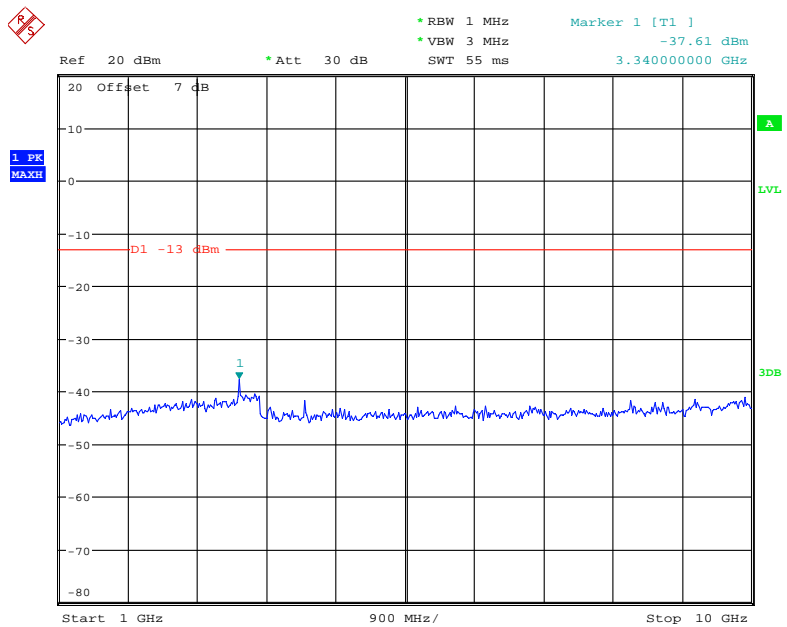

Date: 18.NOV.2020 15:29:44

30 MHz - 1 GHz (5.0 MHz, Middle channel)

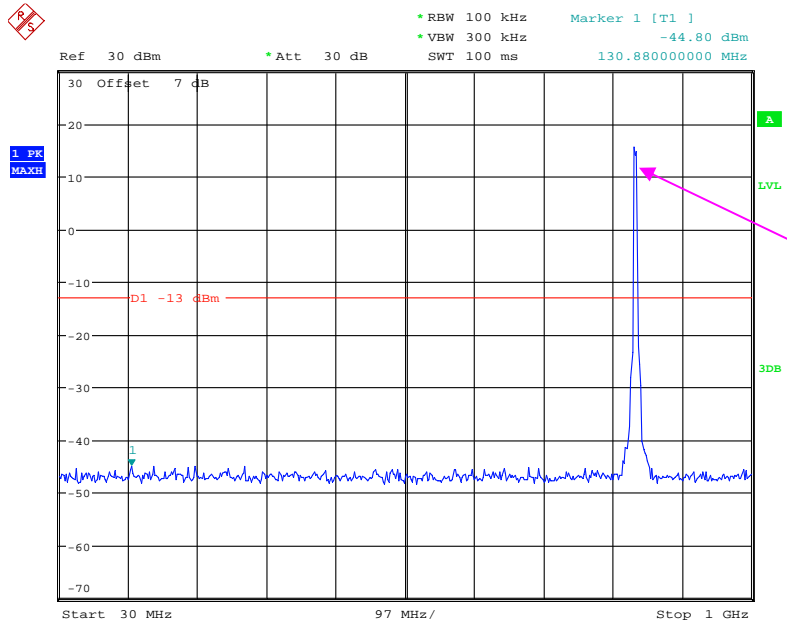

Date: 18.NOV.2020 15:30:03

1 GHz - 10 GHz (5.0 MHz, Middle channel)

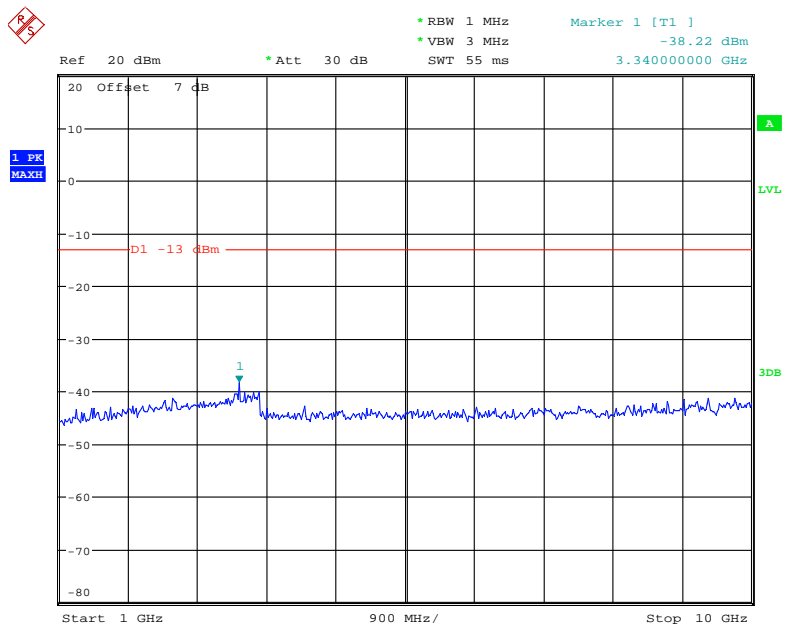

Date: 18.NOV.2020 15:30:15

30 MHz - 1 GHz (10.0 MHz, Middle channel)

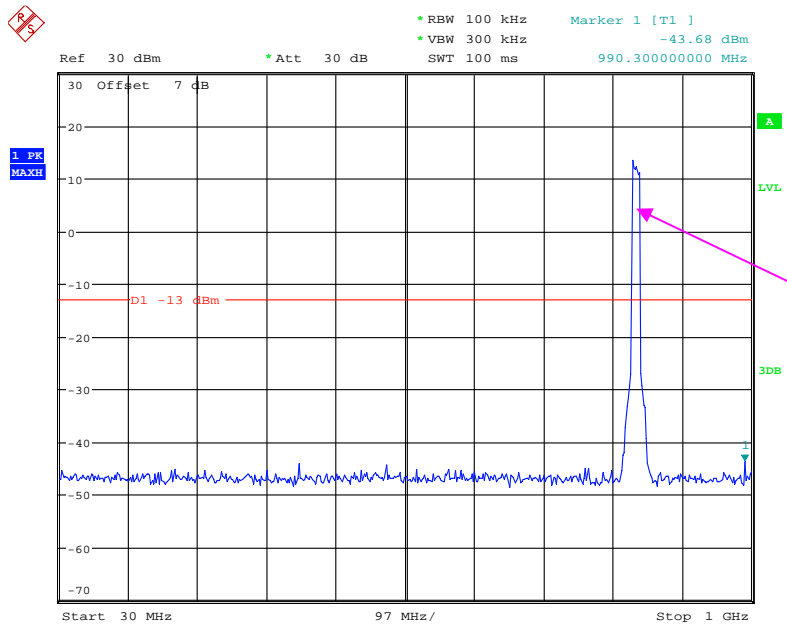

Fundamental test

Date: 18.NOV.2020 15:30:34

1 GHz - 10 GHz (10.0 MHz, Middle channel)

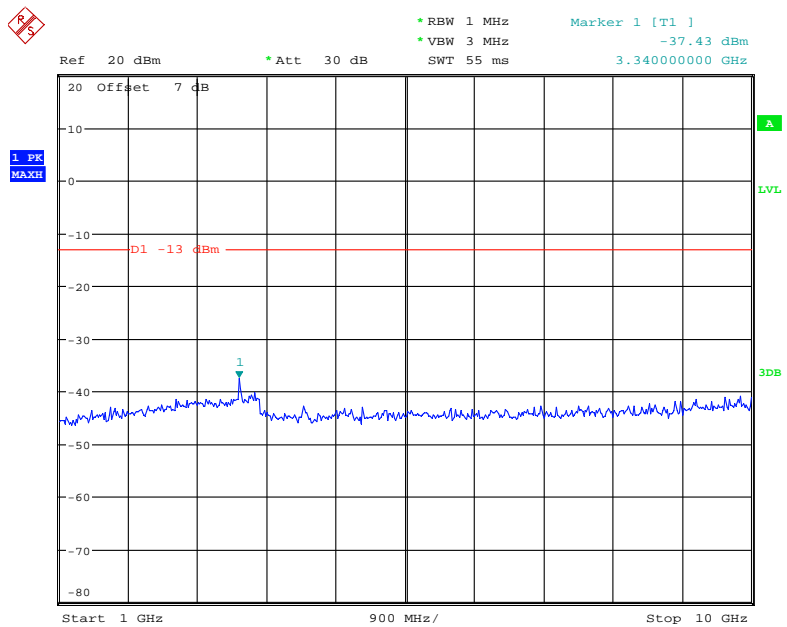

Date: 18.NOV.2020 15:30:45

LTE Band 7:

30 MHz - 1 GHz (5.0 MHz, Middle channel)

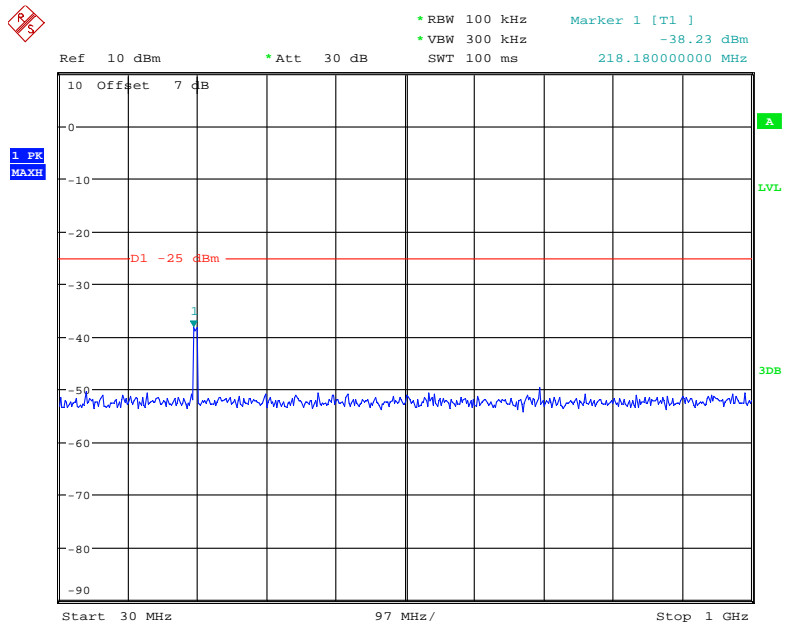

Date: 18.NOV.2020 15:31:05

1 GHz - 26.5 GHz (5.0 MHz, Middle channel)

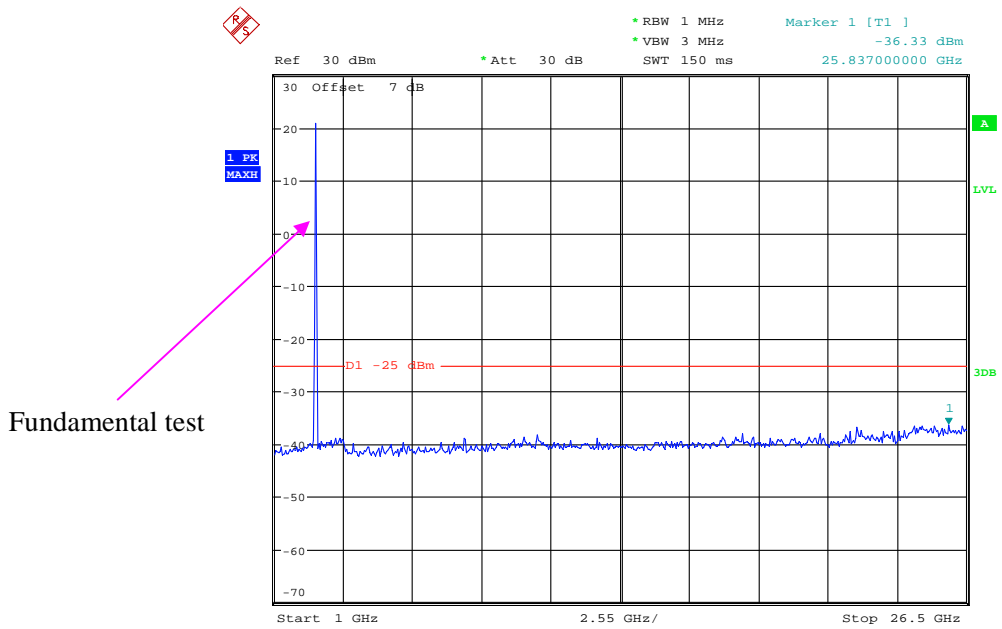

Date: 18.NOV.2020 15:31:16

30 MHz - 1 GHz (10.0 MHz, Middle channel)

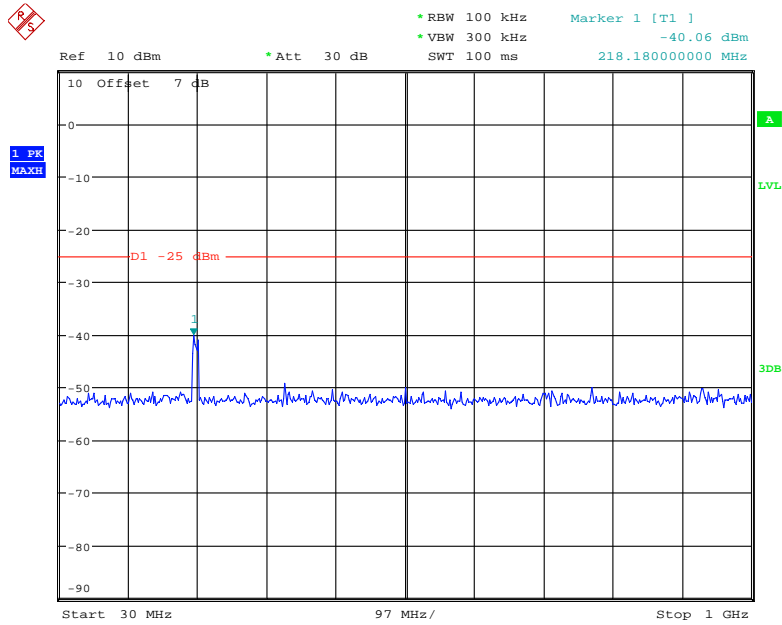

Date: 18.NOV.2020 15:31:36

1 GHz - 26.5 GHz (10.0 MHz, Middle channel)

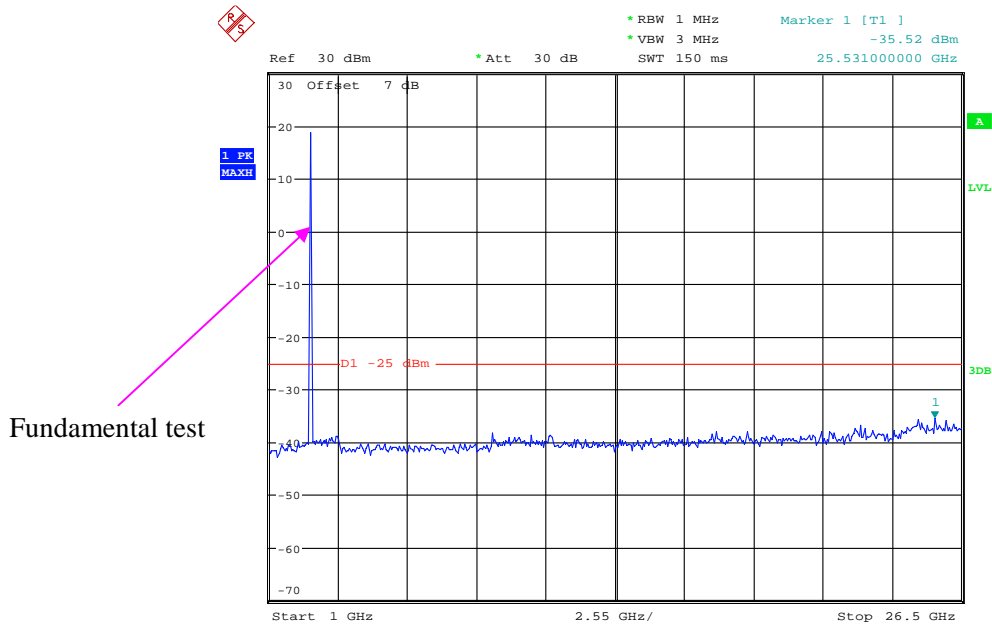

Date: 18.NOV.2020 15:31:47

30 MHz - 1 GHz (15.0 MHz, Middle channel)

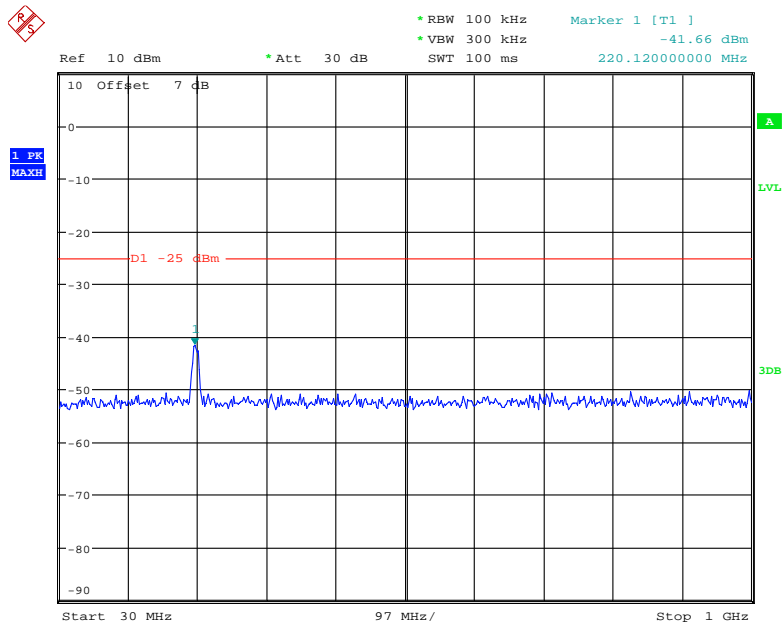

Date: 18.NOV.2020 15:32:10

1 GHz - 26.5 GHz (15.0 MHz, Middle channel)

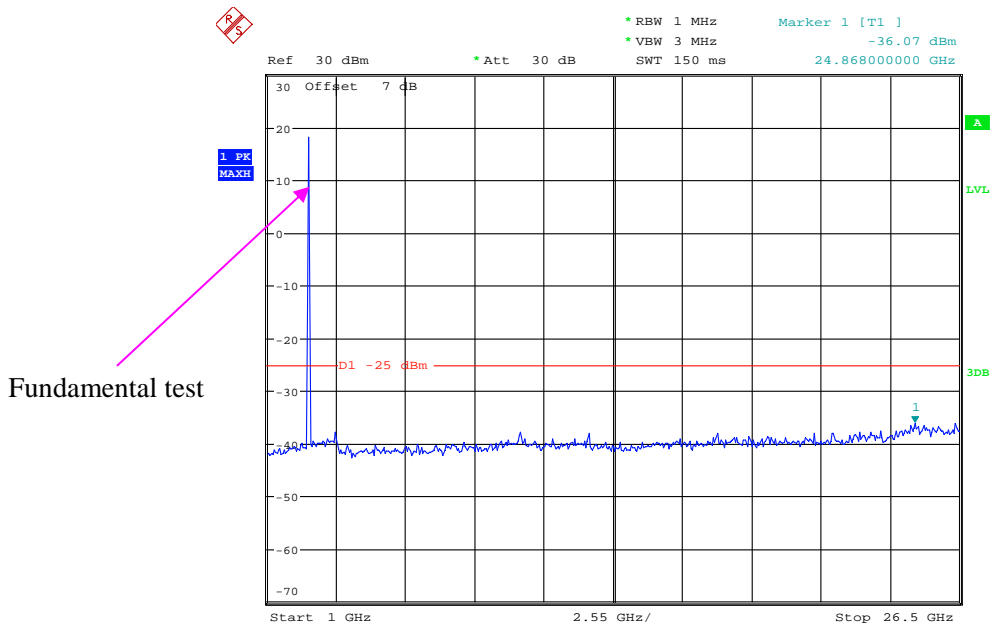

Date: 18.NOV.2020 15:32:21

30 MHz - 1 GHz (20.0 MHz, Middle channel)

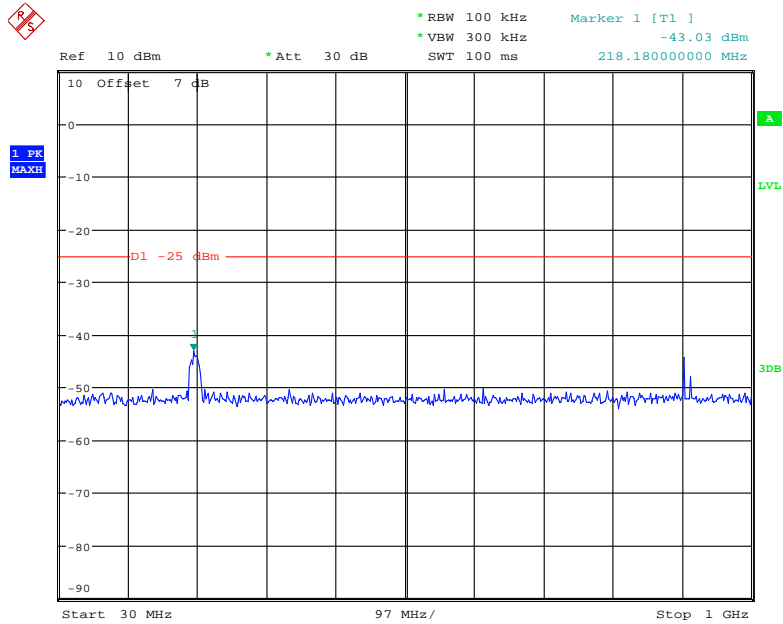

Date: 18.NOV.2020 15:32:47

1 GHz - 26.5 GHz (20.0 MHz, Middle channel)

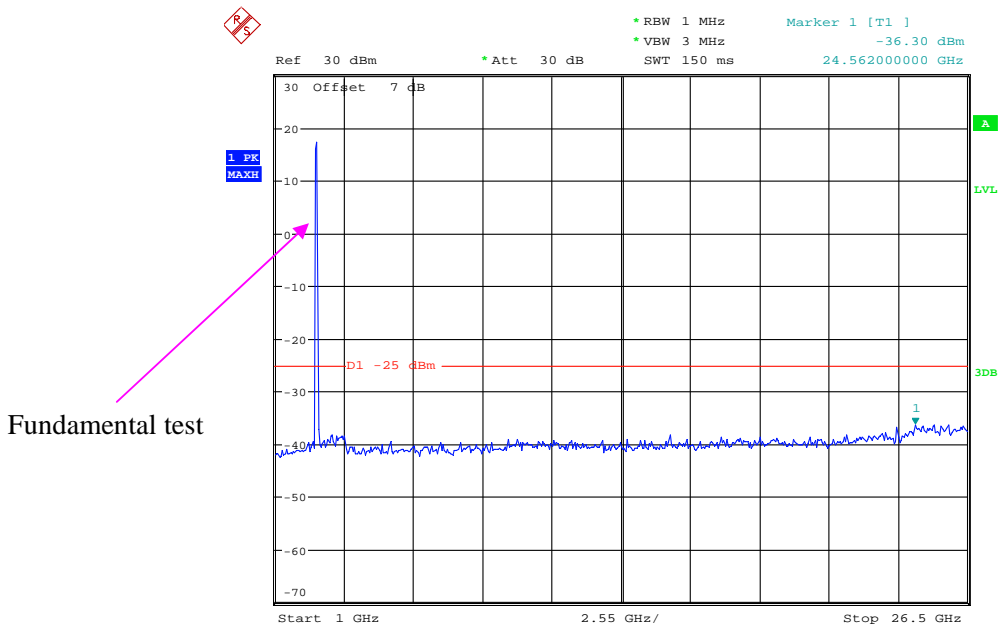

Date: 18.NOV.2020 15:32:59

LTE Band 38:

30 MHz - 1 GHz (5.0 MHz, Middle Channel)

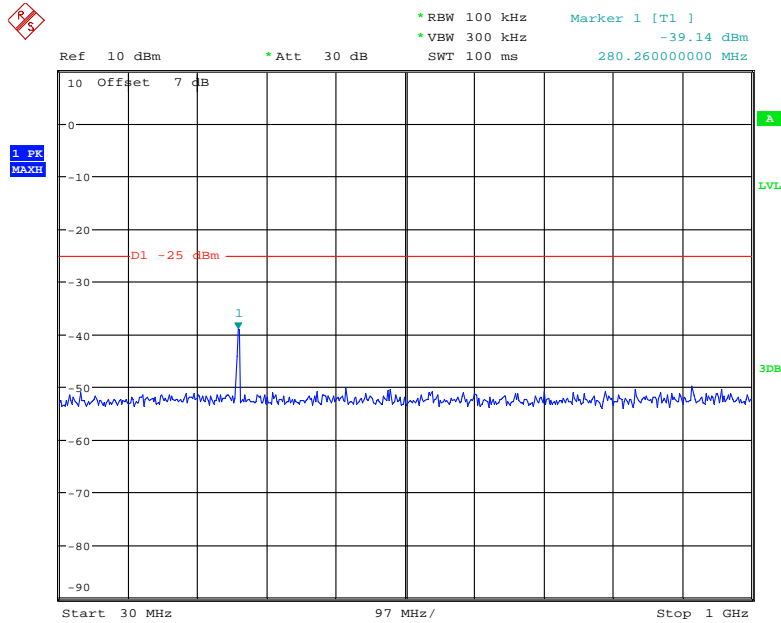

Date: 18.NOV.2020 16:47:29

1 GHz - 26.5 GHz (5.0 MHz, Middle Channel)

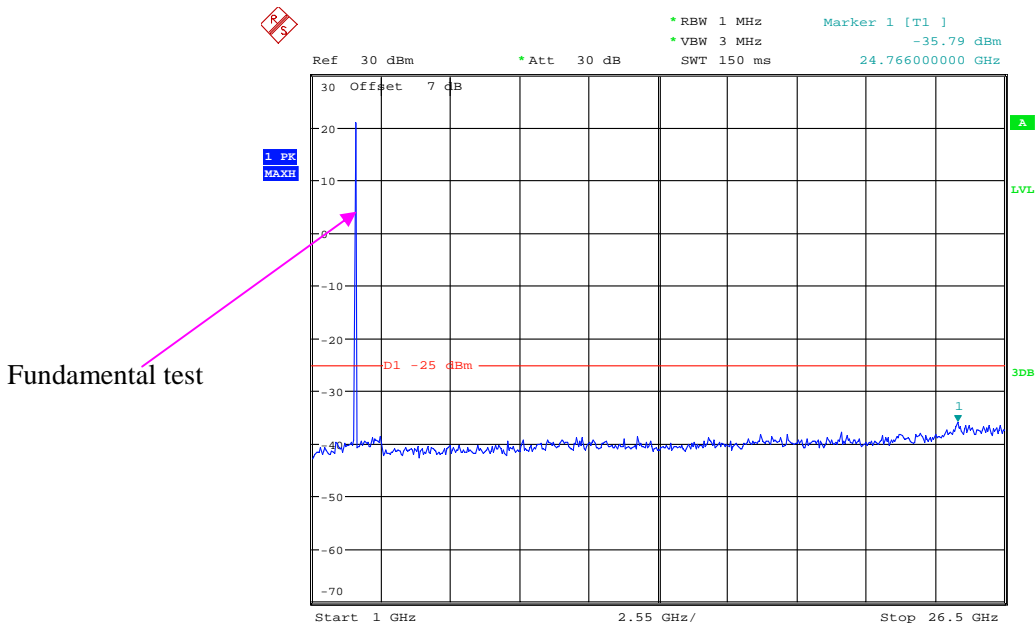

Date: 18.NOV.2020 16:47:41

30 MHz - 1 GHz (10.0 MHz, Middle Channel)

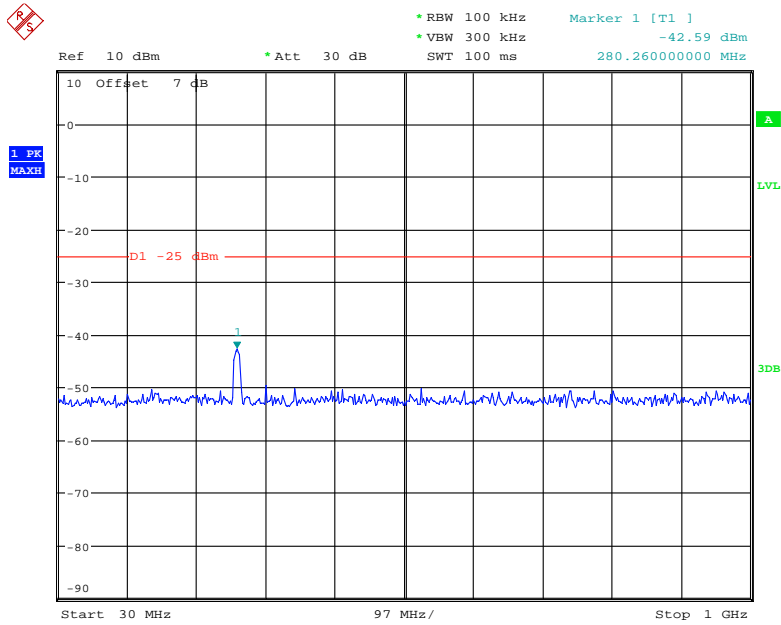

Date: 18.NOV.2020 16:48:00

1 GHz - 26.5 GHz (10.0 MHz, Middle Channel)

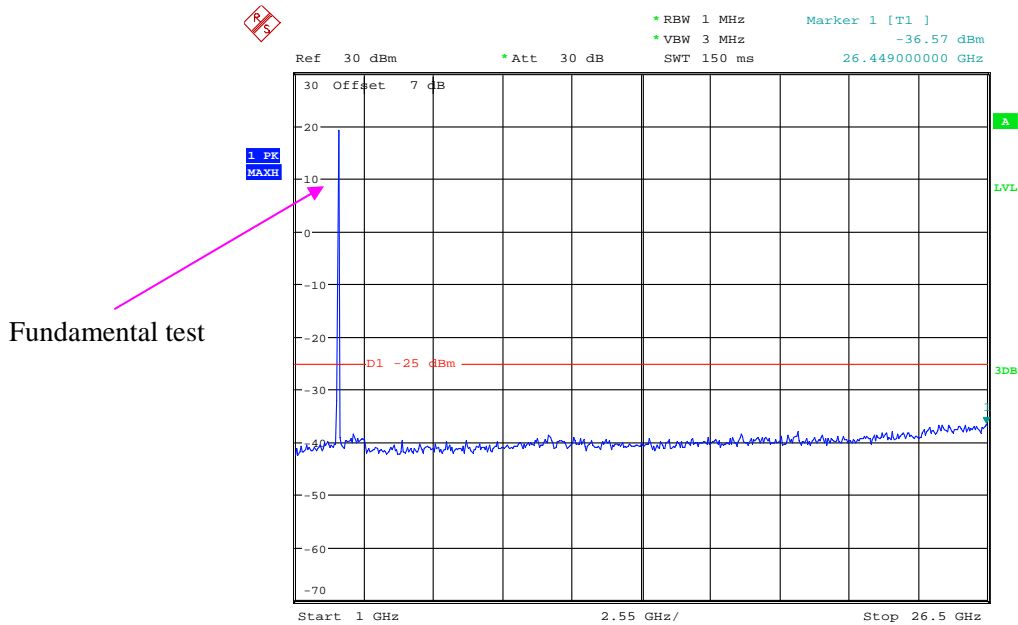

Date: 18.NOV.2020 16:48:11

30 MHz - 1 GHz (15.0 MHz, Middle Channel)

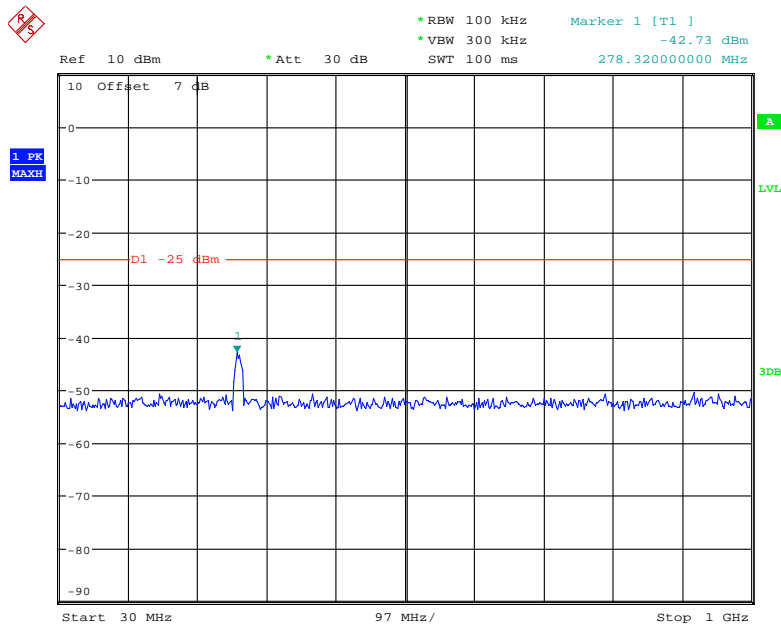

Date: 18.NOV.2020 16:48:33

1 GHz - 26.5 GHz (15.0 MHz, Middle Channel)

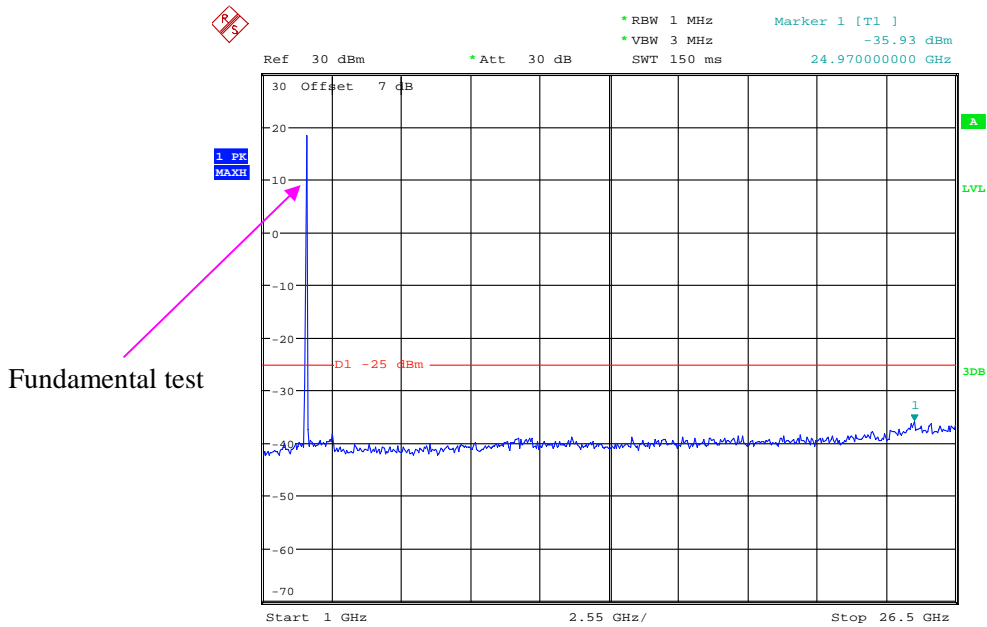

Date: 18.NOV.2020 16:48:44

30 MHz - 1 GHz (20.0 MHz, Middle Channel)

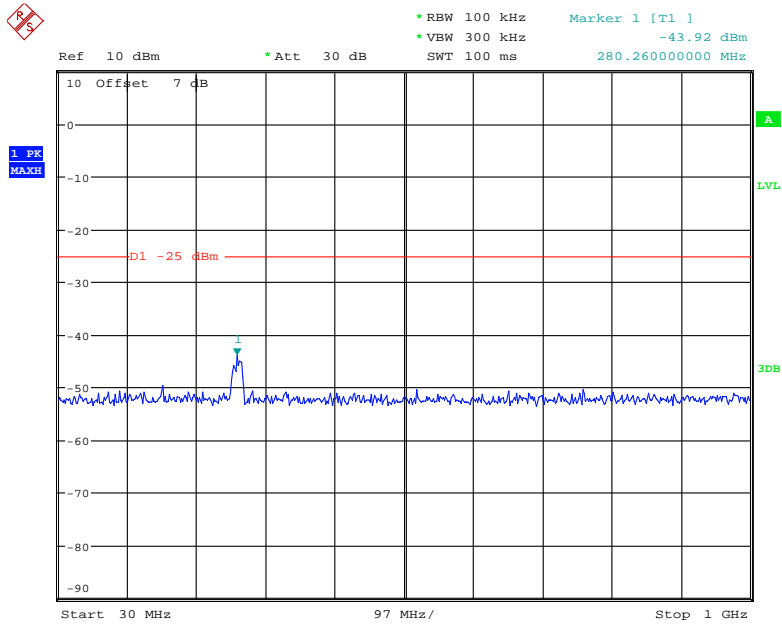

Date: 18.NOV.2020 16:49:09

1 GHz - 26.5 GHz (20.0 MHz, Middle Channel)

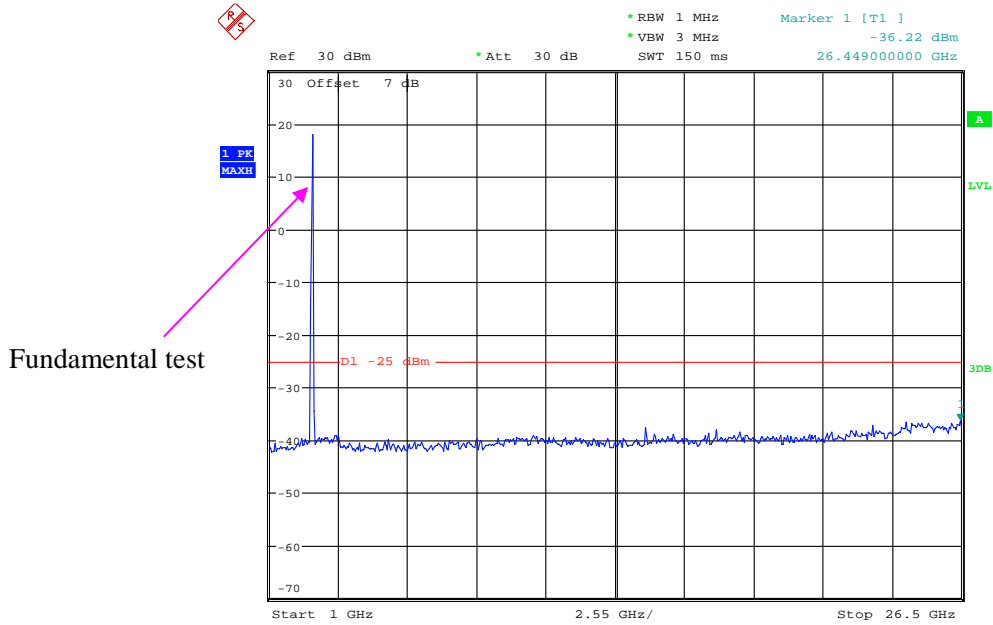

Date: 18.NOV.2020 16:49:20

LTE Band 41:

30 MHz - 1 GHz (5.0 MHz, Middle Channel)

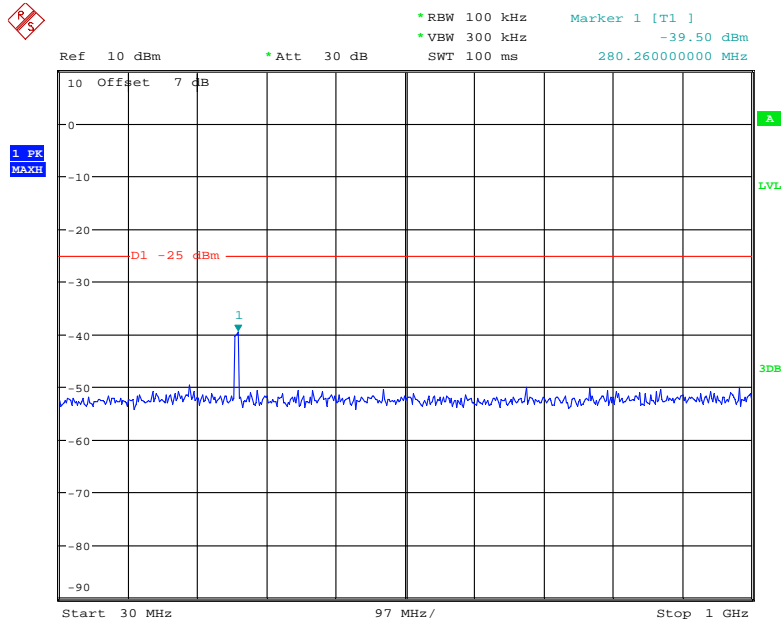

Date: 18.NOV.2020 16:49:39

1 GHz - 26.5 GHz (5.0 MHz, Middle Channel)

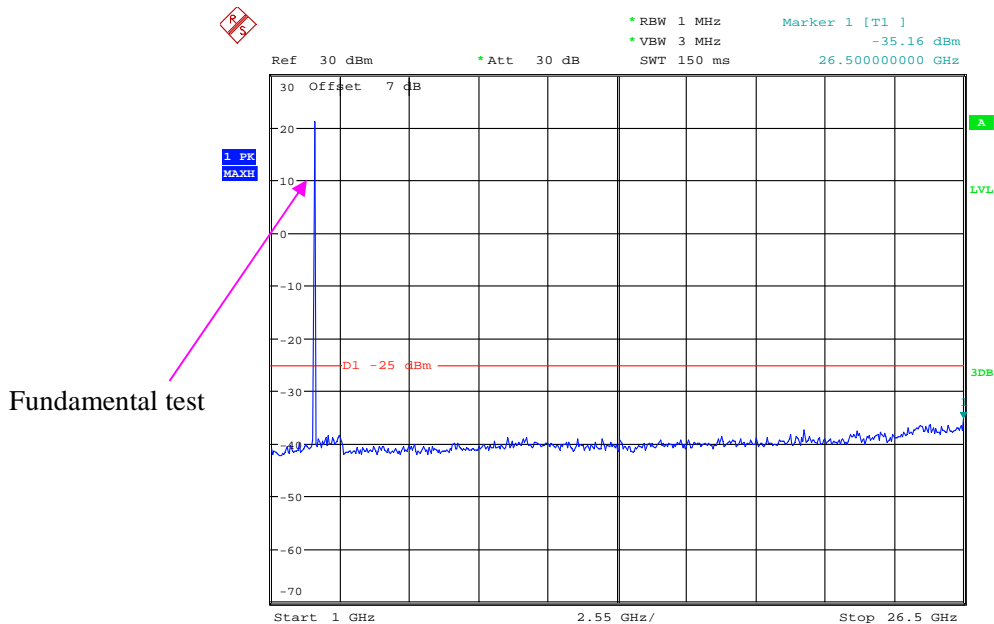

Date: 18.NOV.2020 16:49:50

30 MHz - 1 GHz (10.0 MHz, Middle Channel)

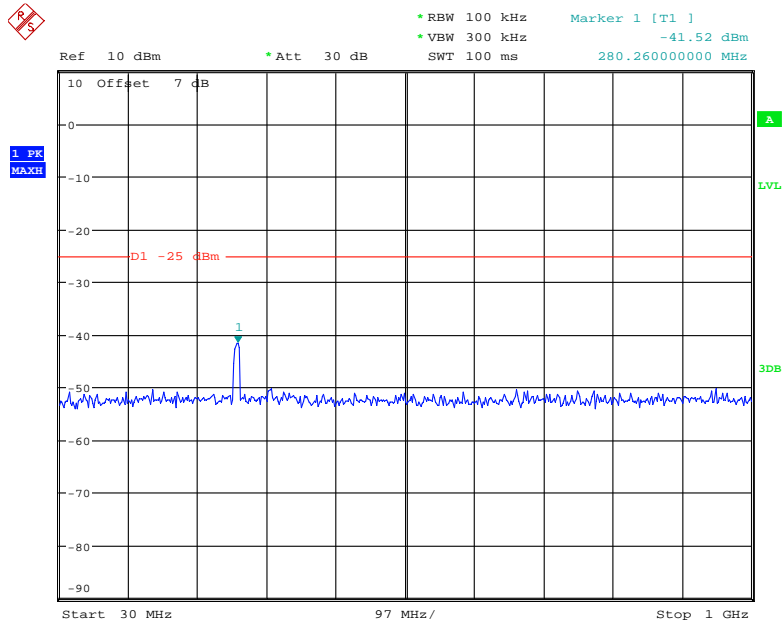

Date: 18.NOV.2020 16:50:09

1 GHz - 26.5 GHz (10.0 MHz, Middle Channel)

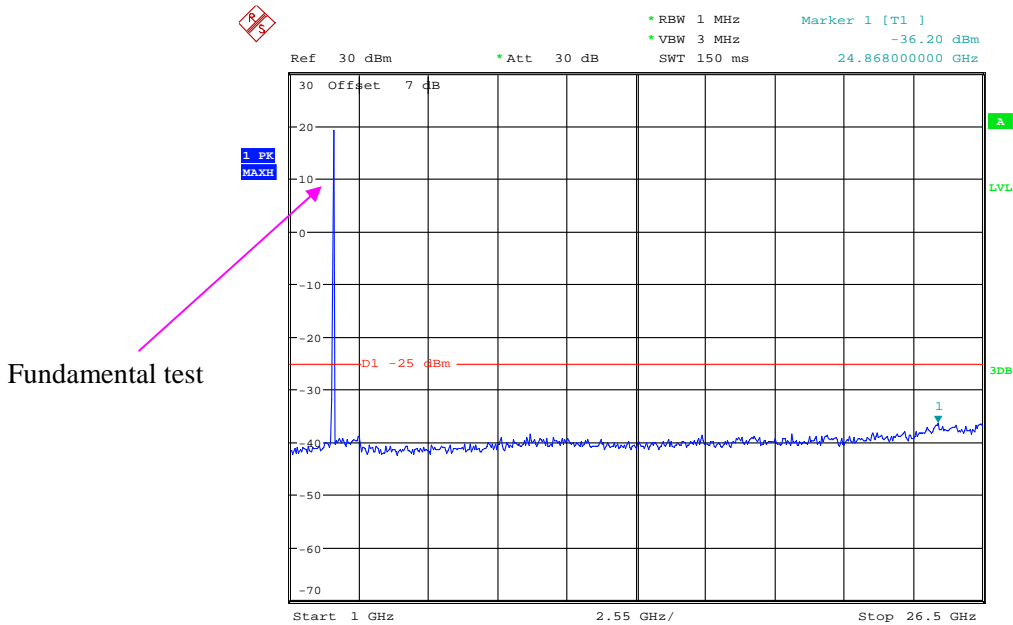

Date: 18.NOV.2020 16:50:21

30 MHz - 1 GHz (15.0 MHz, Middle Channel)

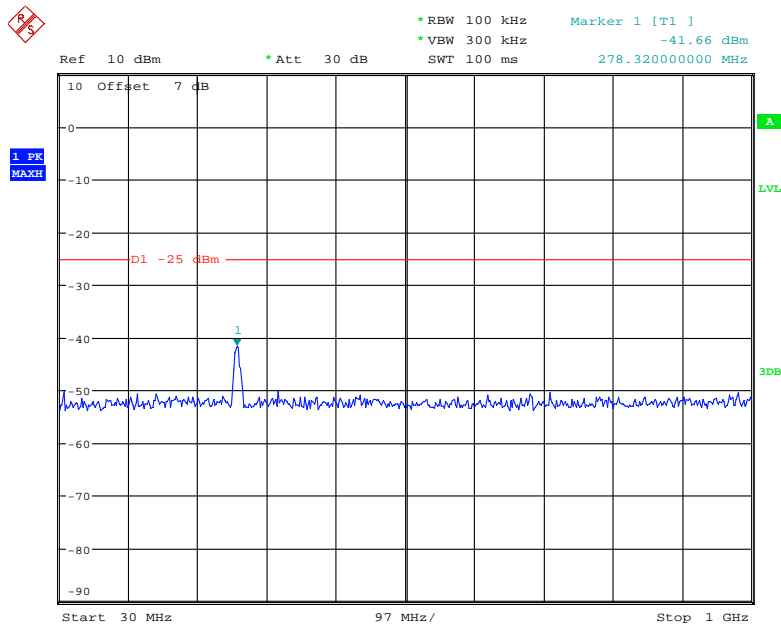

Date: 18.NOV.2020 16:50:42

1 GHz - 26.5 GHz (15.0 MHz, Middle Channel)

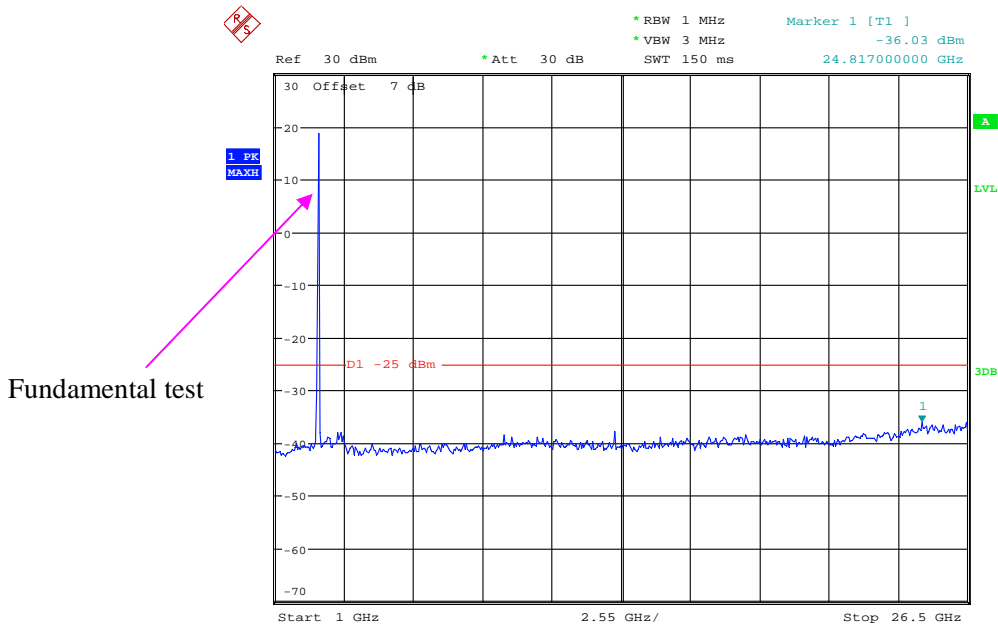

Date: 18.NOV.2020 16:50:54

30 MHz - 1 GHz (20.0 MHz, Middle Channel)

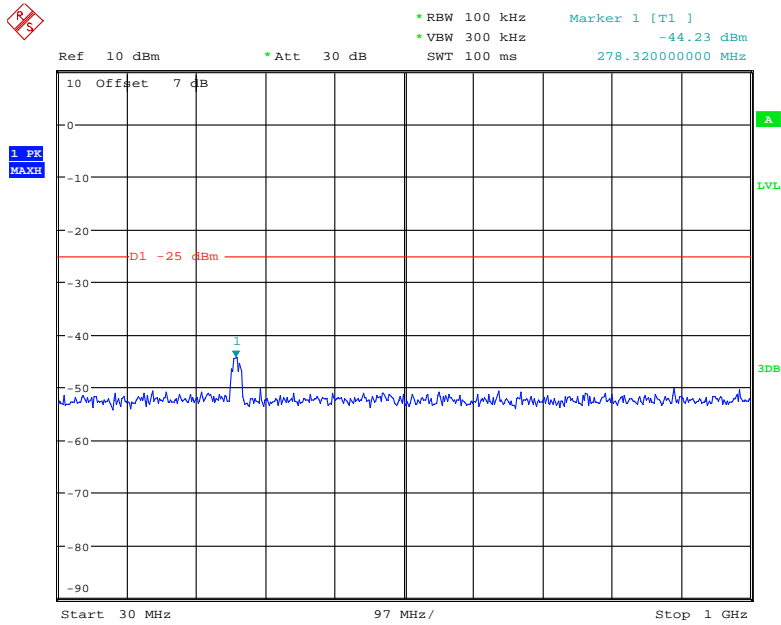

Date: 18.NOV.2020 16:51:15

1 GHz - 26.5 GHz (20.0 MHz, Middle Channel)

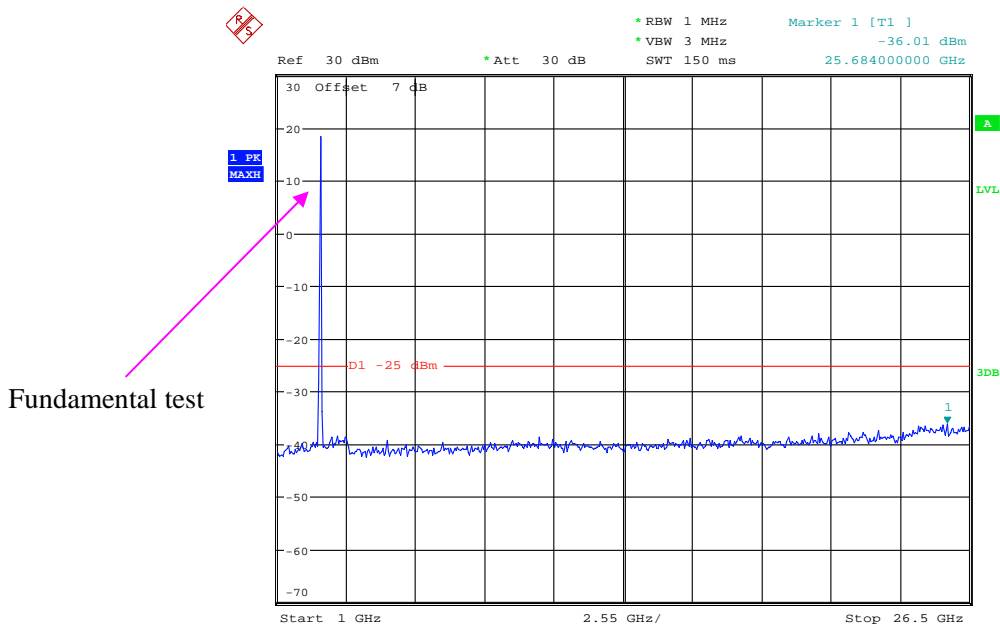

Date: 18.NOV.2020 16:51:27

FCC § 2.1053; § 22.917 (a); § 24.238 (a); §27.53 SPURIOUS RADIATED EMISSIONS

Applicable Standard

FCC § 2.1053, §22.917(a) and § 24.238(a) and § 27.53

Test Procedure

The transmitter was placed on a wooden turntable, and it was transmitting into a non-radiating load which was also placed on the turntable.

The measurement antenna was placed at a distance of 3 meters from the EUT. During the tests, the receiving antenna height and polarization as well as EUT azimuth were varied in order to identify the maximum level of emissions from the EUT. The test was performed by placing the EUT on 3-orthogonal axis.

The frequency range up to tenth harmonic of the fundamental frequency was investigated.

Test Data**Environmental Conditions**

Temperature:	27.4~31.7 °C
Relative Humidity:	42~58 %
ATM Pressure:	100.9~101.0 kPa

The testing was performed by Harris He and Charlie Cha from 2020-11-18 to 2020-11-19 for below 1GHz and Leven gan on 2020-11-18 for above 1GHz.

EUT operation mode: Transmitting

30 MHz ~ 10 GHz:

Cellular Band (Part 22H)

Frequency (MHz)	Receiver Reading (dBµV)	Turntable Angle Degree	Rx Antenna		Substituted			Absolute Level (dBm)	FCC Part 22H	
			Height (m)	Polar (H/V)	Level (dBm)	Cable Loss (dB)	Antenna Gain (dBd/dBi)		Limit (dBm)	Margin (dB)
GSM Mode										
Low channel										
959.7	33.67	344	1.1	H	-62.8	1.36	0.0	-64.16	-13	51.16
959.7	34.24	332	2.4	V	-59.8	1.36	0.0	-61.16	-13	48.16
1648.40	51.27	8	1.5	H	-56.8	1.40	8.70	-49.50	-13	36.50
1648.40	54.34	329	1.3	V	-53.5	1.40	8.70	-46.20	-13	33.20
2472.60	61.10	331	1.4	H	-42.3	2.60	10.20	-34.70	-13	21.70
2472.60	58.69	170	2.2	V	-44.1	2.60	10.20	-36.50	-13	23.50
3296.80	43.37	200	1.4	H	-57.5	1.50	11.70	-47.30	-13	34.30
3296.80	43.15	139	2.1	V	-57.8	1.50	11.70	-47.60	-13	34.60
Middle channel										
958.4	33.76	92	1.2	H	-62.7	1.36	0.0	-64.06	-13	51.06
958.4	34.86	84	2.3	V	-59.2	1.36	0.0	-60.56	-13	47.56
1673.20	50.44	144	2.0	H	-55.9	1.30	8.90	-48.30	-13	35.30
1673.20	54.92	134	2.3	V	-50.8	1.30	8.90	-43.20	-13	30.20
2509.80	60.70	266	1.5	H	-42.7	2.60	10.20	-35.10	-13	22.10
2509.80	59.31	149	2.3	V	-43.4	2.60	10.20	-35.80	-13	22.80
3346.40	43.15	350	1.9	H	-57.7	1.50	11.70	-47.50	-13	34.50
3346.40	43.26	15	1.1	V	-57.7	1.50	11.70	-47.50	-13	34.50
High channel										
961.7	33.55	185	1.3	H	-63.0	1.36	0.0	-64.36	-13	51.36
961.7	34.52	50	1.0	V	-59.5	1.36	0.0	-60.86	-13	47.86
1697.60	52.47	270	1.8	H	-53.9	1.30	8.90	-46.30	-13	33.30
1697.60	51.86	177	2.0	V	-53.9	1.30	8.90	-46.30	-13	33.30
2546.40	57.87	301	2.0	H	-45.5	2.60	10.20	-37.90	-13	24.90
2546.40	58.04	262	1.4	V	-44.7	2.60	10.20	-37.10	-13	24.10
3395.20	43.52	216	1.1	H	-57.7	1.40	11.80	-47.30	-13	34.30
3395.20	42.95	143	2.5	V	-58.1	1.40	11.80	-47.70	-13	34.70

Frequency (MHz)	Receiver Reading (dBµV)	Turntable Angle Degree	Rx Antenna		Substituted			Absolute Level (dBm)	FCC Part 22H	
			Height (m)	Polar (H/V)	Level (dBm)	Cable Loss (dB)	Antenna Gain (dBd/dBi)		Limit (dBm)	Margin (dB)
WCDMA Mode										
Low channel										
952.3	33.74	247	2.2	H	-62.8	1.36	0.0	-64.16	-13	51.16
952.3	34.09	340	2.4	V	-60.0	1.36	0.0	-61.36	-13	48.36
1652.80	46.89	342	2.0	H	-59.4	1.30	8.90	-51.80	-13	38.80
1652.80	47.18	352	2.1	V	-58.6	1.30	8.90	-51.00	-13	38.00
2479.20	44.23	336	1.2	H	-59.1	2.60	10.20	-51.50	-13	38.50
2479.20	44.58	293	1.4	V	-58.2	2.60	10.20	-50.60	-13	37.60
3305.60	47.18	143	1.1	H	-53.7	1.50	11.70	-43.50	-13	30.50
3305.60	46.19	69	2.3	V	-54.7	1.50	11.70	-44.50	-13	31.50
Middle channel										
953.6	33.24	25	2.5	H	-63.3	1.36	0.0	-64.66	-13	51.66
953.6	34.52	206	2.4	V	-59.5	1.36	0.0	-60.86	-13	47.86
1673.20	47.23	272	1.2	H	-59.1	1.30	8.90	-51.50	-13	38.50
1673.20	47.14	265	1.1	V	-58.6	1.30	8.90	-51.00	-13	38.00
2509.80	44.06	162	1.0	H	-59.3	2.60	10.20	-51.70	-13	38.70
2509.80	44.54	270	2.0	V	-58.2	2.60	10.20	-50.60	-13	37.60
3346.40	47.08	140	1.7	H	-53.8	1.50	11.70	-43.60	-13	30.60
3346.40	46.22	81	1.3	V	-54.7	1.50	11.70	-44.50	-13	31.50
High channel										
966.8	33.20	340	1.6	H	-63.3	1.36	0.0	-64.66	-13	51.66
966.8	34.36	149	1.5	V	-59.7	1.36	0.0	-61.06	-13	48.06
1693.20	47.34	320	2.0	H	-59.0	1.30	8.90	-51.40	-13	38.40
1693.20	47.08	267	1.9	V	-58.7	1.30	8.90	-51.10	-13	38.10
2539.80	44.32	200	1.7	H	-59.0	2.60	10.20	-51.40	-13	38.40
2539.80	44.81	48	1.6	V	-57.9	2.60	10.20	-50.30	-13	37.30
3386.40	46.98	259	1.9	H	-54.3	1.40	11.80	-43.90	-13	30.90
3386.40	45.86	353	1.5	V	-55.2	1.40	11.80	-44.80	-13	31.80

30 MHz ~ 20 GHz:

PCS Band (Part 24E)

Frequency (MHz)	Receiver Reading (dBµV)	Turntable Angle Degree	Rx Antenna		Substituted			Absolute Level (dBm)	FCC Part 24E	
			Height (m)	Polar (H/V)	Level (dBm)	Cable Loss (dB)	Antenna Gain (dBd/dBi)		Limit (dBm)	Margin (dB)
GSM Mode										
Low channel										
959.3	33.68	73	1.3	H	-62.8	1.36	0.0	-64.16	-13	51.16
959.3	34.75	313	1.2	V	-59.3	1.36	0.0	-60.66	-13	47.66
3700.40	43.98	31	1.4	H	-57.8	1.60	11.90	-47.50	-13	34.50
3700.40	43.72	169	1.1	V	-57.5	1.60	11.90	-47.20	-13	34.20
Middle channel										
962.6	33.45	154	2.4	H	-63.1	1.36	0.0	-64.46	-13	51.46
962.6	34.62	267	2.3	V	-59.4	1.36	0.0	-60.76	-13	47.76
3760.00	44.16	294	1.8	H	-57.9	1.50	11.80	-47.60	-13	34.60
3760.00	43.87	11	1.9	V	-57.7	1.50	11.80	-47.40	-13	34.40
High channel										
961.4	33.38	162	1.2	H	-63.1	1.36	0.0	-64.46	-13	51.46
961.4	34.47	67	2.0	V	-59.6	1.36	0.0	-60.96	-13	47.96
3819.60	44.23	243	1.8	H	-57.8	1.50	11.80	-47.50	-13	34.50
3819.60	44.02	54	2.1	V	-57.6	1.50	11.80	-47.30	-13	34.30

Frequency (MHz)	Receiver Reading (dBµV)	Turntable Angle Degree	Rx Antenna		Substituted			Absolute Level (dBm)	FCC Part 24E	
			Height (m)	Polar (H/V)	Level (dBm)	Cable Loss (dB)	Antenna Gain (dBd/dBi)		Limit (dBm)	Margin (dB)
WCDMA Mode										
Low channel										
967.8	33.77	259	2.0	H	-62.7	1.36	0.0	-64.06	-13	51.06
967.8	34.86	290	2.4	V	-59.2	1.36	0.0	-60.56	-13	47.56
3704.80	49.89	104	1.8	H	-51.9	1.60	11.90	-41.60	-13	28.60
3704.80	49.73	219	1.0	V	-51.5	1.60	11.90	-41.20	-13	28.20
Middle channel										
959.0	33.63	233	2.4	H	-62.9	1.36	0.0	-64.26	-13	51.26
959.0	34.95	42	2.3	V	-59.1	1.36	0.0	-60.46	-13	47.46
3760.00	49.83	232	1.7	H	-52.2	1.50	11.80	-41.90	-13	28.90
3760.00	50.24	121	1.3	V	-51.3	1.50	11.80	-41.00	-13	28.00
High channel										
960.1	33.81	124	2.1	H	-62.7	1.36	0.0	-64.06	-13	51.06
960.1	34.22	75	2.2	V	-59.8	1.36	0.0	-61.16	-13	48.16
3815.20	49.78	241	1.2	H	-52.3	1.50	11.80	-42.00	-13	29.00
3815.20	49.91	330	1.4	V	-51.7	1.50	11.80	-41.40	-13	28.40

30 MHz ~ 20 GHz:

AWS Band

Frequency (MHz)	Receiver Reading (dBµV)	Turntable Angle Degree	Rx Antenna		Substituted			Absolute Level (dBm)	FCC Part 27	
			Height (m)	Polar (H/V)	Level (dBm)	Cable Loss (dB)	Antenna Gain (dBd/dBi)		Limit (dBm)	Margin (dB)
WCDMA Mode										
Low channel										
956.8	33.67	340	1.4	H	-62.8	1.36	0.0	-64.16	-13	51.16
956.8	34.66	21	1.1	V	-59.4	1.36	0.0	-60.76	-13	47.76
3424.80	44.18	334	1.5	H	-56.6	1.40	11.80	-46.20	-13	33.20
3424.80	44.36	120	1.3	V	-56.2	1.40	11.80	-45.80	-13	32.80
Middle channel										
955.7	33.05	203	1.5	H	-63.5	1.36	0.0	-64.86	-13	51.86
955.7	34.06	243	2.0	V	-60.0	1.36	0.0	-61.36	-13	48.36
3465.20	44.23	10	1.7	H	-56.5	1.50	12.00	-46.00	-13	33.00
3465.20	44.52	85	1.7	V	-57.0	1.50	12.00	-46.50	-13	33.50
High channel										
961.5	33.65	160	1.4	H	-62.9	1.36	0.0	-64.26	-13	51.26
961.5	34.75	355	1.0	V	-59.3	1.36	0.0	-60.66	-13	47.66
3505.20	43.98	217	1.5	H	-56.8	1.50	12.00	-46.30	-13	33.30
3505.20	44.38	135	2.4	V	-57.1	1.50	12.00	-46.60	-13	33.60

LTE Band: (Pre-scan with all the bandwidth, and worst case as below)

Frequency (MHz)	Receiver Reading (dBµV)	Turntable Angle Degree	Rx Antenna		Substituted			Absolute Level (dBm)	Limit (dBm)	Margin (dB)
			Height (m)	Polar (H/V)	Level (dBm)	Cable Loss (dB)	Antenna Gain (dBd/dBi)			
Band 2										
Test frequency range: 30 MHz ~ 20 GHz										
1.4 MHz, Low channel										
958.6	33.22	233	2.1	H	-63.3	1.36	0.0	-64.66	-13	51.66
958.6	34.31	51	2.1	V	-59.7	1.36	0.0	-61.06	-13	48.06
3701.40	52.59	180	1.7	H	-49.2	1.60	11.90	-38.90	-13	25.90
3701.40	54.78	287	2.3	V	-46.4	1.60	11.90	-36.10	-13	23.10
1.4 MHz, Middle channel										
960.2	33.31	339	2.4	H	-63.2	1.36	0.0	-64.56	-13	51.56
960.2	34.44	145	2.2	V	-59.6	1.36	0.0	-60.96	-13	47.96
3760.00	52.74	160	2.3	H	-49.3	1.50	11.80	-39.00	-13	26.00
3760.00	54.99	37	1.2	V	-46.6	1.50	11.80	-36.30	-13	23.30
1.4 MHz, High channel										
964.5	33.46	284	1.3	H	-63.0	1.36	0.0	-64.36	-13	51.36
964.5	34.66	31	2.3	V	-59.4	1.36	0.0	-60.76	-13	47.76
3818.60	52.47	168	2.0	H	-49.6	1.50	11.80	-39.30	-13	26.30
3818.60	55.31	329	1.9	V	-46.3	1.50	11.80	-36.00	-13	23.00
Band 4										
Test frequency range:30 MHz ~ 20 GHz										
1.4 MHz, Low channel										
965.9	33.71	214	1.0	H	-62.8	1.36	0.0	-64.16	-13	51.16
965.9	34.88	273	1.6	V	-59.2	1.36	0.0	-60.56	-13	47.56
3421.40	44.87	20	1.2	H	-55.9	1.40	11.80	-45.50	-13	32.50
3421.40	44.92	204	1.4	V	-55.7	1.40	11.80	-45.30	-13	32.30
1.4 MHz, Middle channel										
966.1	33.69	198	2.2	H	-62.8	1.36	0.0	-64.16	-13	51.16
966.1	34.87	115	2.4	V	-59.2	1.36	0.0	-60.56	-13	47.56
3465.00	44.56	345	2.5	H	-56.2	1.50	12.00	-45.70	-13	32.70
3465.00	45.09	112	1.2	V	-56.4	1.50	12.00	-45.90	-13	32.90
1.4 MHz, High channel										
967.4	33.54	323	1.0	H	-63.0	1.36	0.0	-64.36	-13	51.36
967.4	34.15	59	2.0	V	-59.9	1.36	0.0	-61.26	-13	48.26
3508.60	43.89	214	2.4	H	-56.9	1.50	12.00	-46.40	-13	33.40
3508.60	44.35	196	1.6	V	-57.2	1.50	12.00	-46.70	-13	33.70

Frequency (MHz)	Receiver Reading (dBμV)	Turntable Angle Degree	Rx Antenna		Substituted			Absolute Level (dBm)	Limit (dBm)	Margin (dB)
			Height (m)	Polar (H/V)	Level (dBm)	Cable Loss (dB)	Antenna Gain (dBd/dBi)			
Band 5										
Test frequency range:30 MHz ~ 10 GHz										
1.4 MHz, Low channel										
956.0	33.24	110	2.3	H	-63.3	1.36	0.0	-64.66	-13	51.66
956.0	34.63	312	1.9	V	-59.4	1.36	0.0	-60.76	-13	47.76
1649.40	46.42	134	1.4	H	-61.7	1.40	8.70	-54.40	-13	41.40
1649.40	47.12	28	2.1	V	-60.7	1.40	8.70	-53.40	-13	40.40
2474.10	44.38	111	2.3	H	-59.0	2.60	10.20	-51.40	-13	38.40
2474.10	45.69	52	2.3	V	-57.1	2.60	10.20	-49.50	-13	36.50
3298.80	48.12	99	1.9	H	-52.8	1.50	11.70	-42.60	-13	29.60
3298.80	49.55	302	1.7	V	-51.4	1.50	11.70	-41.20	-13	28.20
1.4 MHz, Middle channel										
958.3	33.04	37	1.3	H	-63.5	1.36	0.0	-64.86	-13	51.86
958.3	34.33	242	1.4	V	-59.7	1.36	0.0	-61.06	-13	48.06
1673.00	45.99	290	1.7	H	-60.3	1.30	8.90	-52.70	-13	39.70
1673.00	46.98	92	2.5	V	-58.8	1.30	8.90	-51.20	-13	38.20
2509.50	44.45	145	1.0	H	-58.9	2.60	10.20	-51.30	-13	38.30
2509.50	45.75	285	1.9	V	-57.0	2.60	10.20	-49.40	-13	36.40
3346.00	48.07	40	1.1	H	-52.8	1.50	11.70	-42.60	-13	29.60
3346.00	49.64	314	1.8	V	-51.3	1.50	11.70	-41.10	-13	28.10
1.4 MHz, High channel										
961.2	33.60	291	1.5	H	-62.9	1.36	0.0	-64.26	-13	51.26
961.2	34.73	349	2.1	V	-59.3	1.36	0.0	-60.66	-13	47.66
1696.60	46.36	62	2.3	H	-60.0	1.30	8.90	-52.40	-13	39.40
1696.60	46.87	51	1.3	V	-58.9	1.30	8.90	-51.30	-13	38.30
2544.90	44.45	331	1.1	H	-58.9	2.60	10.20	-51.30	-13	38.30
2544.90	45.96	268	2.2	V	-56.8	2.60	10.20	-49.20	-13	36.20
3393.20	48.01	236	1.1	H	-53.2	1.40	11.80	-42.80	-13	29.80
3393.20	49.58	281	1.3	V	-51.5	1.40	11.80	-41.10	-13	28.10
Band 7										
Test frequency range: 30 MHz ~ 26.5 GHz										
5 MHz, Low channel										
951.3	33.55	111	1.1	H	-63.0	1.36	0.0	-64.36	-25	39.36
951.3	34.78	288	2.0	V	-59.3	1.36	0.0	-60.66	-25	35.66
5005.00	44.98	274	1.3	H	-55.6	1.70	12.00	-45.30	-25	20.30
5005.00	43.95	55	1.3	V	-56.1	1.70	12.00	-45.80	-25	20.80
5 MHz, Middle channel										
957.6	33.06	142	1.7	H	-63.4	1.36	0.0	-64.76	-25	39.76
957.6	34.36	221	1.9	V	-59.7	1.36	0.0	-61.06	-25	36.06
5070.00	44.85	303	1.3	H	-55.2	1.60	12.10	-44.70	-25	19.70
5070.00	44.29	279	2.0	V	-55.7	1.60	12.10	-45.20	-25	20.20
5 MHz, High channel										
966.7	33.12	54	1.4	H	-63.4	1.36	0.0	-64.76	-25	39.76
966.7	34.34	293	1.7	V	-59.7	1.36	0.0	-61.06	-25	36.06
5135.00	44.43	321	1.1	H	-55.6	1.60	12.10	-45.10	-25	20.10
5135.00	45.02	234	1.2	V	-55.0	1.60	12.10	-44.50	-25	19.50

Frequency (MHz)	Receiver Reading (dBμV)	Turntable Angle Degree	Rx Antenna		Substituted			Absolute Level (dBm)	Limit (dBm)	Margin (dB)
			Height (m)	Polar (H/V)	Level (dBm)	Cable Loss (dB)	Antenna Gain (dBd/dBi)			
Band 38										
Test frequency range: 30 MHz ~26.5GHz										
5 MHz, Low channel										
962.6	33.72	54	1.0	H	-62.8	1.36	0.0	-64.16	-25	39.16
962.6	34.88	118	2.1	V	-59.2	1.36	0.0	-60.56	-25	35.56
5145.00	46.15	265	1.8	H	-53.9	1.60	12.10	-43.40	-25	18.40
5145.00	46.66	72	2.0	V	-53.4	1.60	12.10	-42.90	-25	17.90
5 MHz, Middle channel										
961.8	33.11	52	2.2	H	-63.4	1.36	0.0	-64.76	-25	39.76
961.8	34.34	315	1.8	V	-59.7	1.36	0.0	-61.06	-25	36.06
5190.00	46.07	275	2.5	H	-54.0	1.60	12.10	-43.50	-25	18.50
5190.00	46.57	206	1.3	V	-53.0	1.60	12.10	-42.50	-25	17.50
5 MHz, High channel										
964.2	33.13	200	2.3	H	-63.4	1.36	0.0	-64.76	-25	39.76
964.2	34.61	166	2.1	V	-59.4	1.36	0.0	-60.76	-25	35.76
5235.00	45.98	83	1.2	H	-54.1	1.60	12.10	-43.60	-25	18.60
5235.00	46.59	106	1.1	V	-53.0	1.60	12.10	-42.50	-25	17.50
Band 41										
Test frequency range: 30 MHz ~ 26.5GHz										
5 MHz, Low channel										
961.6	33.67	225	1.2	H	-62.8	1.36	0.0	-64.16	-25	39.16
961.6	34.81	337	1.4	V	-59.2	1.36	0.0	-60.56	-25	35.56
5075.00	46.87	293	1.6	H	-53.1	1.60	12.10	-42.60	-25	17.60
5075.00	46.35	198	2.3	V	-53.7	1.60	12.10	-43.20	-25	18.20
5 MHz, Middle channel										
952.7	33.27	244	1.1	H	-63.2	1.36	0.0	-64.56	-25	39.56
952.7	34.56	313	2.5	V	-59.5	1.36	0.0	-60.86	-25	35.86
5186.00	46.36	360	2.4	H	-53.7	1.60	12.10	-43.20	-25	18.20
5186.00	45.76	274	1.8	V	-53.9	1.60	12.10	-43.40	-25	18.40
5 MHz, High channel										
960.1	33.45	82	1.1	H	-63.1	1.36	0.0	-64.46	-25	39.46
960.1	34.67	208	1.9	V	-59.4	1.36	0.0	-60.76	-25	35.76
5305.00	46.47	17	2.3	H	-53.3	1.60	12.20	-42.70	-25	17.70
5305.00	46.01	280	2.5	V	-53.2	1.60	12.20	-42.60	-25	17.60

Note:

Absolute Level = Substituted Level - Cable loss + Antenna Gain

Margin = Limit- Absolute Level

dBd is for the ERP, dBi is for EIRP.

FCC § 22.917 (a); § 24.238 (a); §27.53 (h)(m) - BAND EDGES

Applicable Standard

According to § 22.917(a), the power of any emissions outside of the authorized operating frequency ranges must be attenuated below the transmitting power (P) by a factor of at least $43 + 10 \log(P)$ dB.

According to §24.238(a), the power of any emissions outside of the authorized operating frequency ranges must be attenuated below the transmitting power (P) by a factor of at least $43 + 10 \log(P)$ dB.

According to FCC §27.53 (h)(m), the power of any emission outside of the authorized operating frequency ranges must be attenuated below the transmitting power (P) by a factor of at least $43 + 10 \log(P)$ dB.

Test Procedure

The RF output of the transmitter was connected to the input of the spectrum analyzer through sufficient attenuation.

The center of the spectrum analyzer was set to block edge frequency

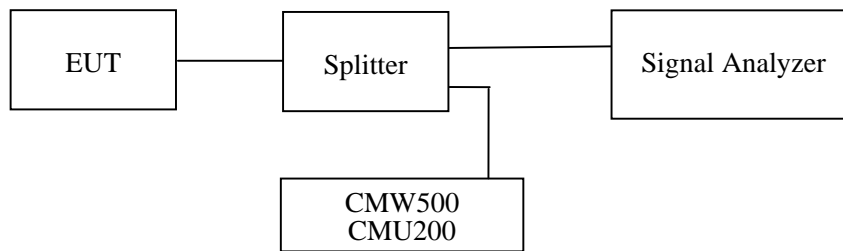

Test Data

Environmental Conditions

Temperature:	25 °C
Relative Humidity:	55 %
ATM Pressure:	101.0 kPa

The testing was performed by Coco Liu from 2020-11-09 to 2020-11-26.

EUT operation mode: Transmitting (Worst case)

Test Result: Pass

Please refer to the following plots.

Cellular Band, Left Band Edge for GSM (GMSK) Mode

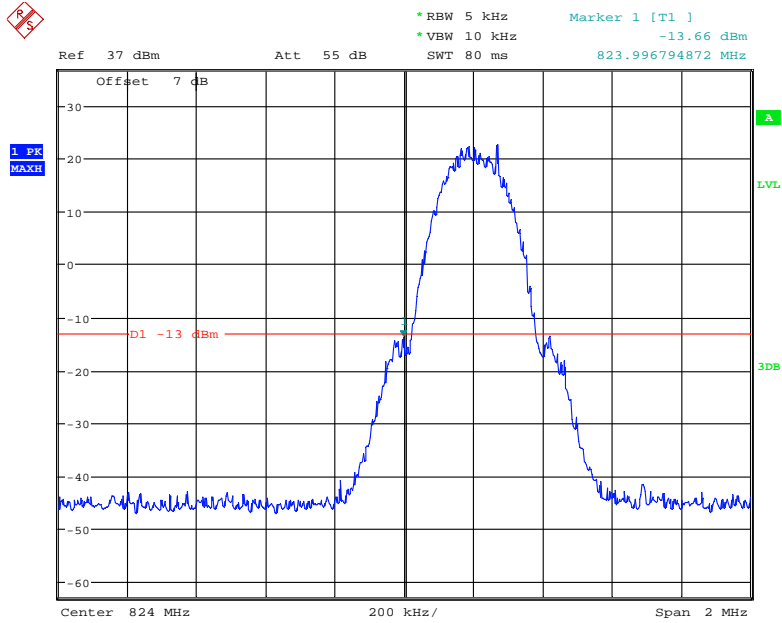

Date: 22.NOV.2020 11:18:20

Cellular Band, Right Band Edge for GSM (GMSK) Mode

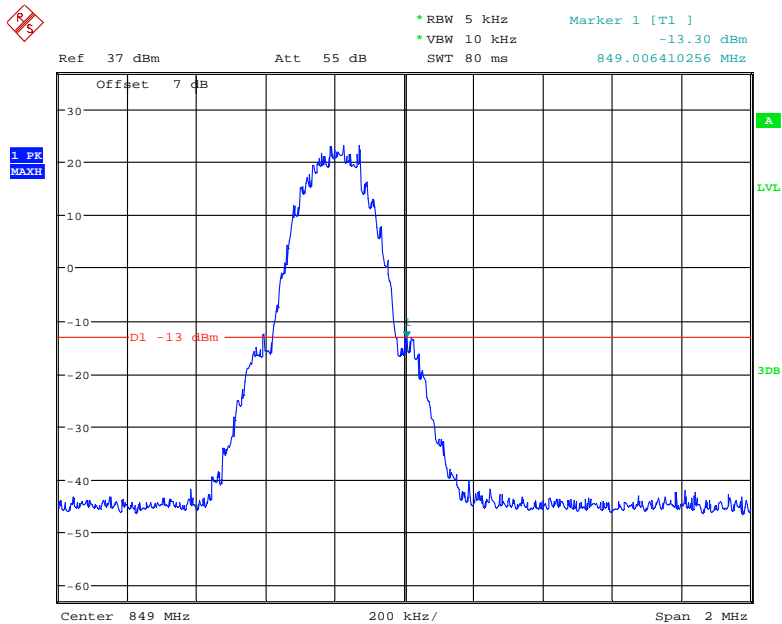

Date: 22.NOV.2020 11:19:26

Cellular Band, Left Band Edge for EGPRS (GMSK) Mode

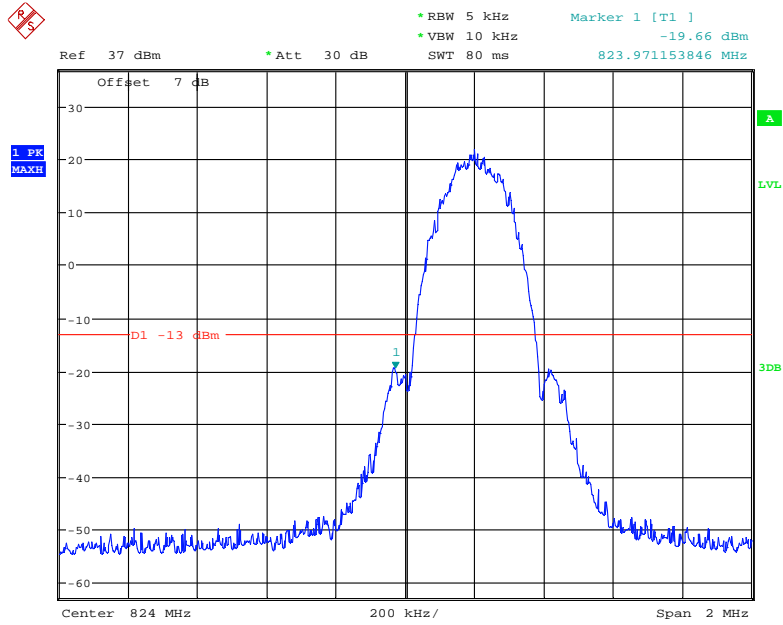

Date: 9.NOV.2020 11:45:00

Cellular Band, Right Band Edge for EGPRS (GMSK) Mode

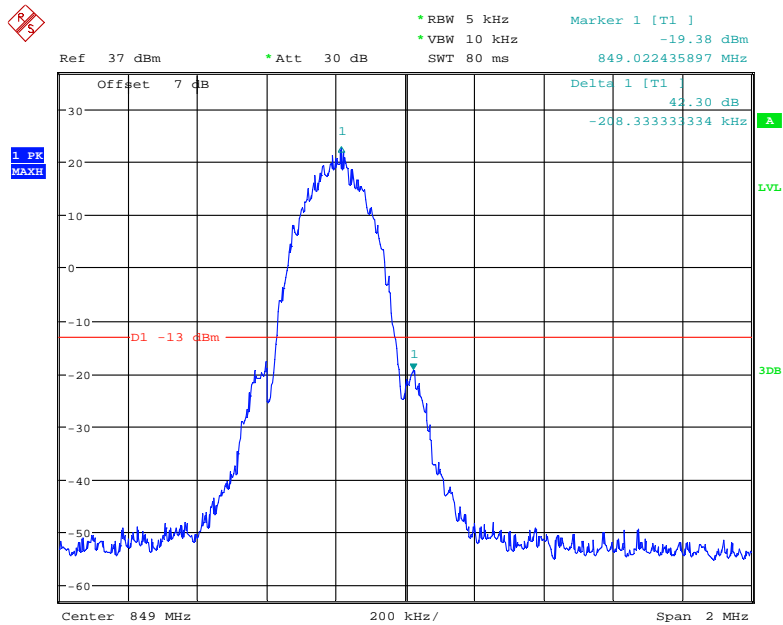

Date: 9.NOV.2020 11:43:56

Cellular Band, Left Band Edge for WCDMA (BPSK) Mode

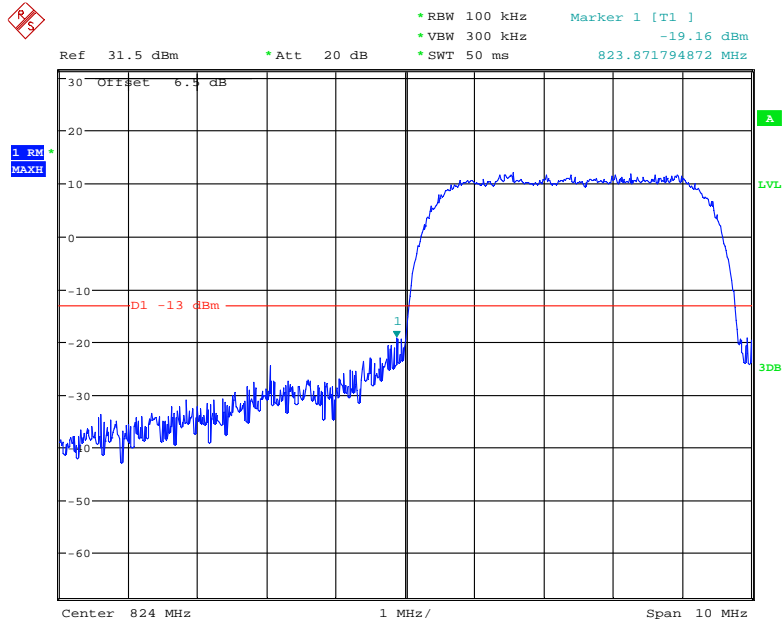

Date: 23.NOV.2020 11:21:04

Cellular Band, Right Band Edge for WCDMA (BPSK) Mode

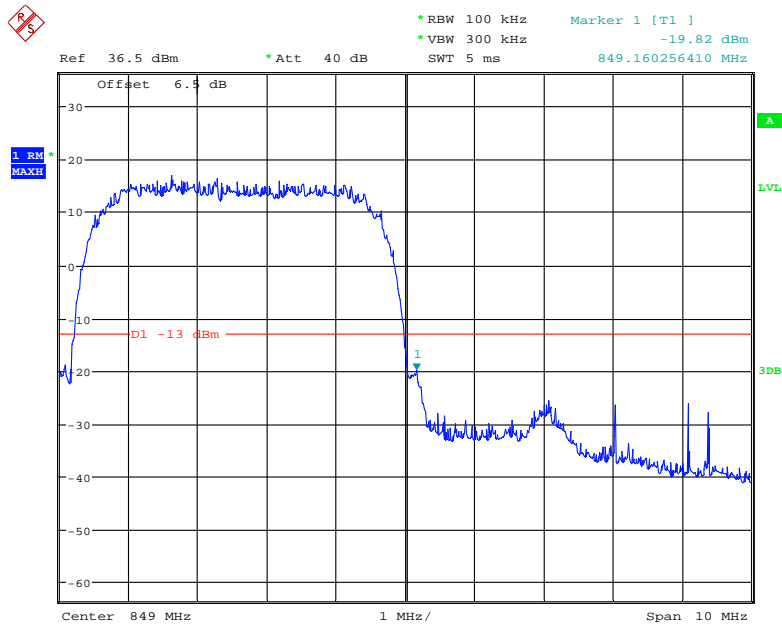

Date: 17.NOV.2020 15:35:46

Cellular Band, Left Band Edge for HSDPA (16QAM) Mode

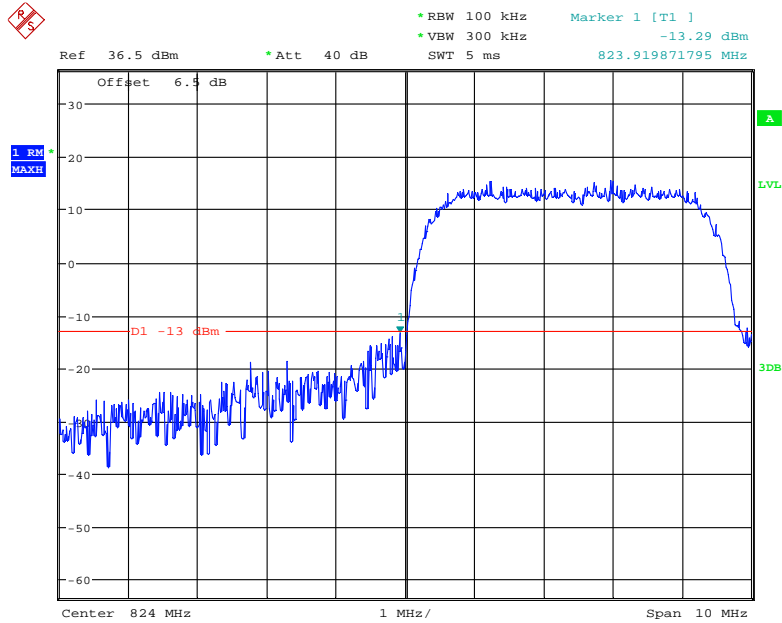

Date: 17.NOV.2020 15:29:10

Cellular Band, Right Band Edge for HSDPA (16QAM) Mode

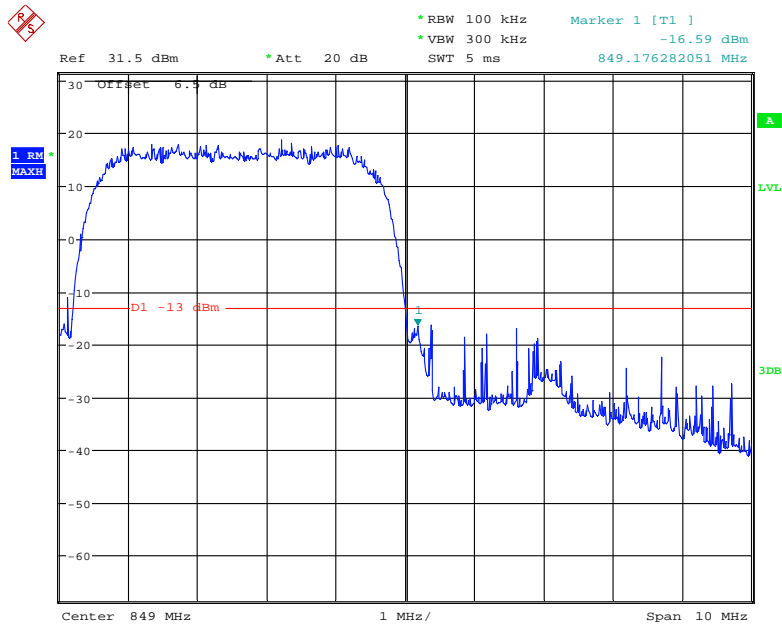

Date: 23.NOV.2020 08:56:06

Cellular Band, Left Band Edge for HSUPA (BPSK) Mode

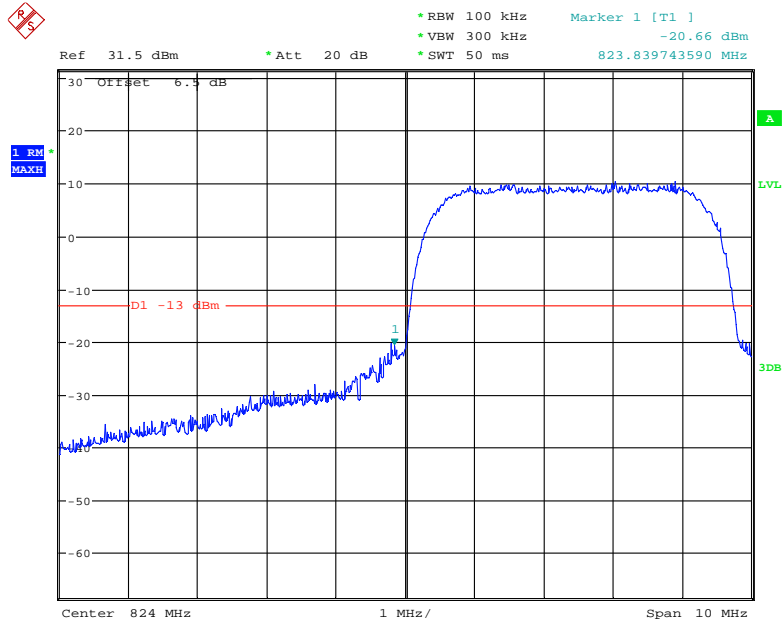

Date: 23.NOV.2020 11:26:56

Cellular Band, Right Band Edge for HSUPA (BPSK) Mode

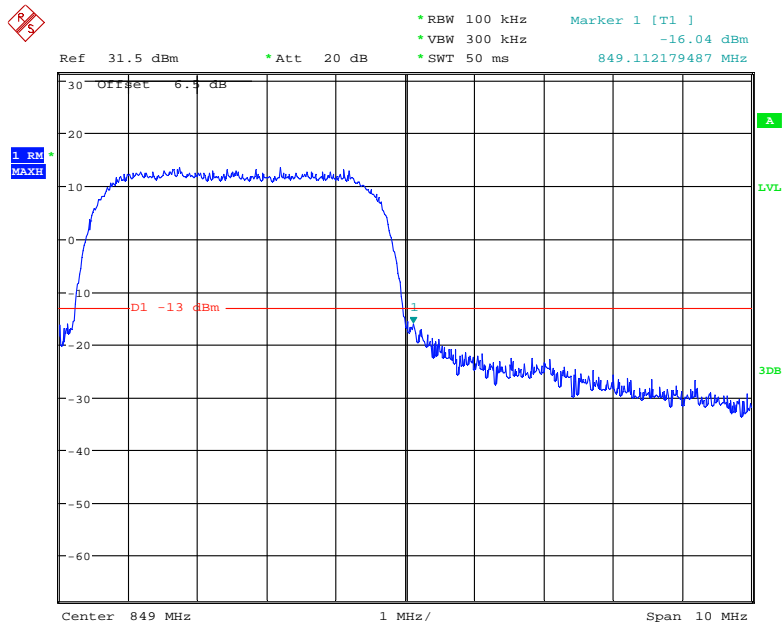

Date: 23.NOV.2020 11:28:03

PCS Band, Left Band Edge for GSM (GMSK) Mode

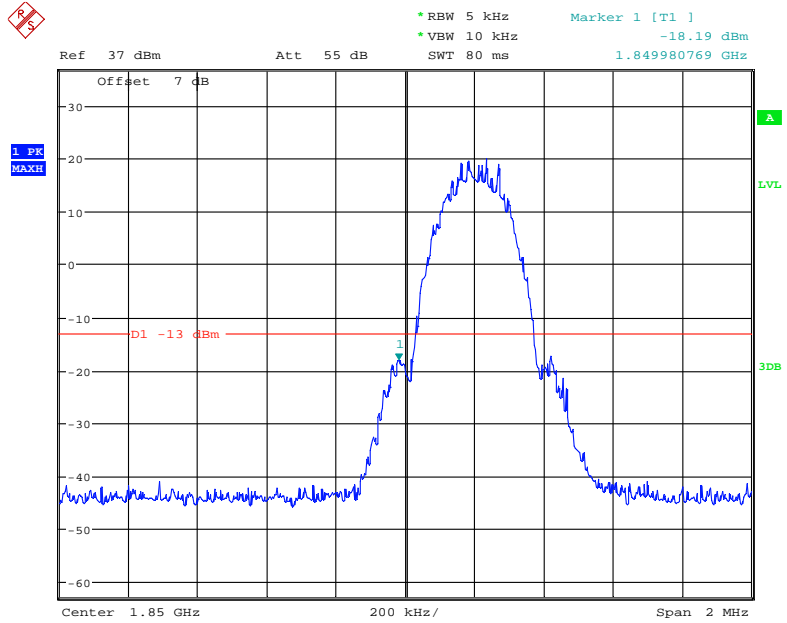

Date: 22.NOV.2020 11:23:10

PCS Band, Right Band Edge for GSM (GMSK) Mode

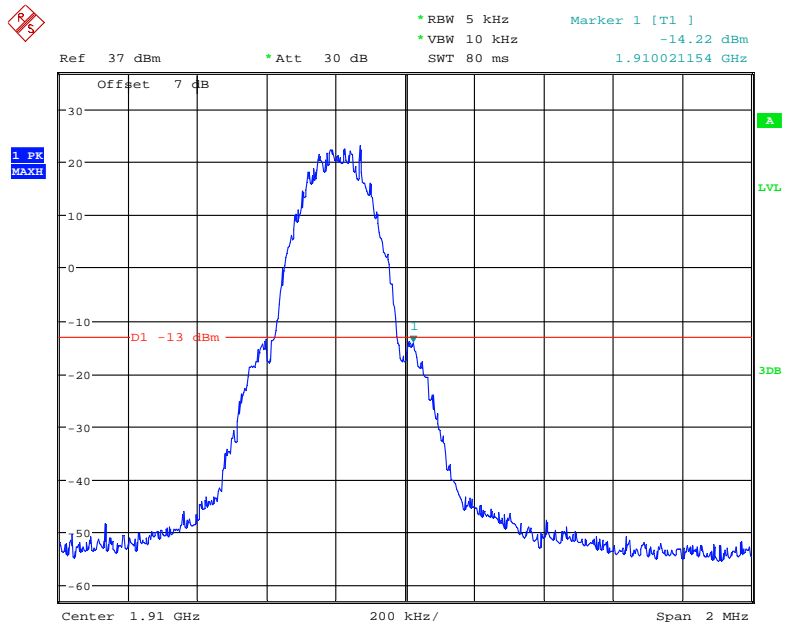

Date: 9.NOV.2020 12:07:23

PCS Band, Left Band Edge for EGPRS (GMSK) Mode

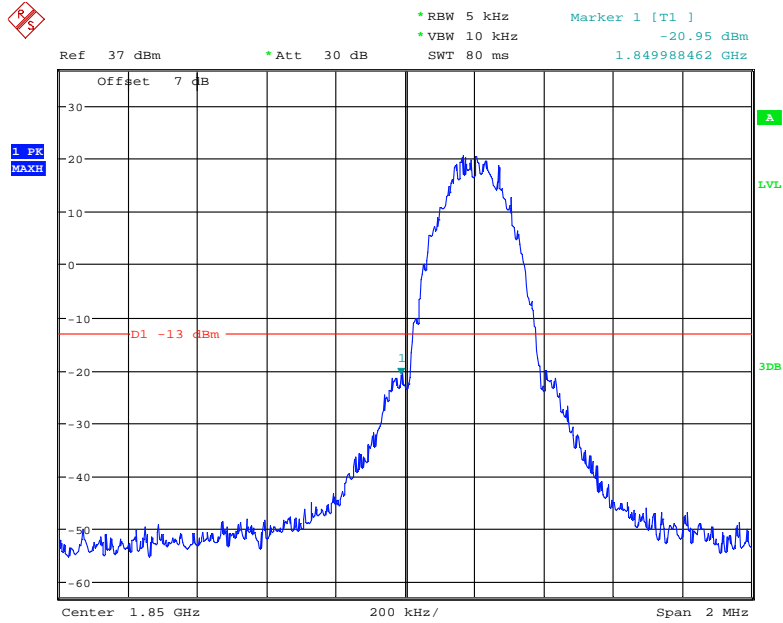

Date: 9.NOV.2020 12:10:32

PCS Band, Right Band Edge for EGPRS (GMSK) Mode

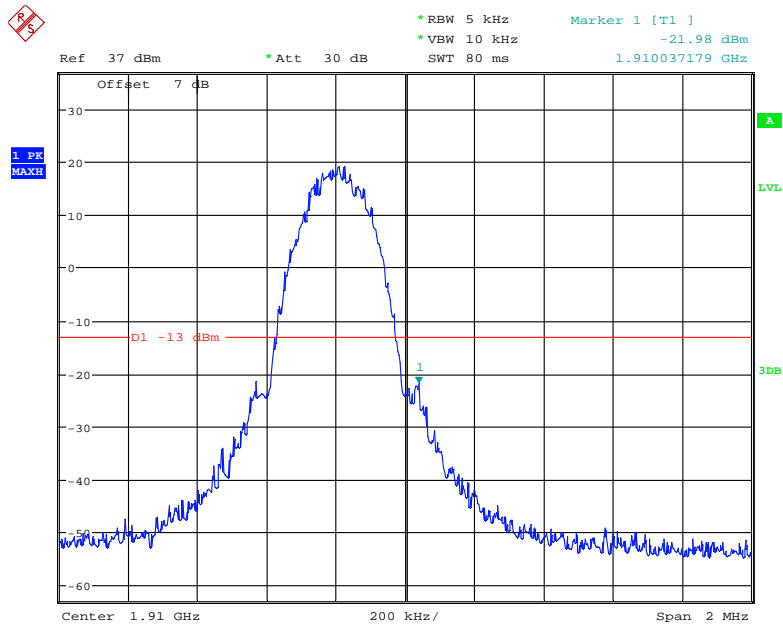

Date: 9.NOV.2020 12:11:17

PCS Band, Left Band Edge for WCDMA (BPSK) Mode

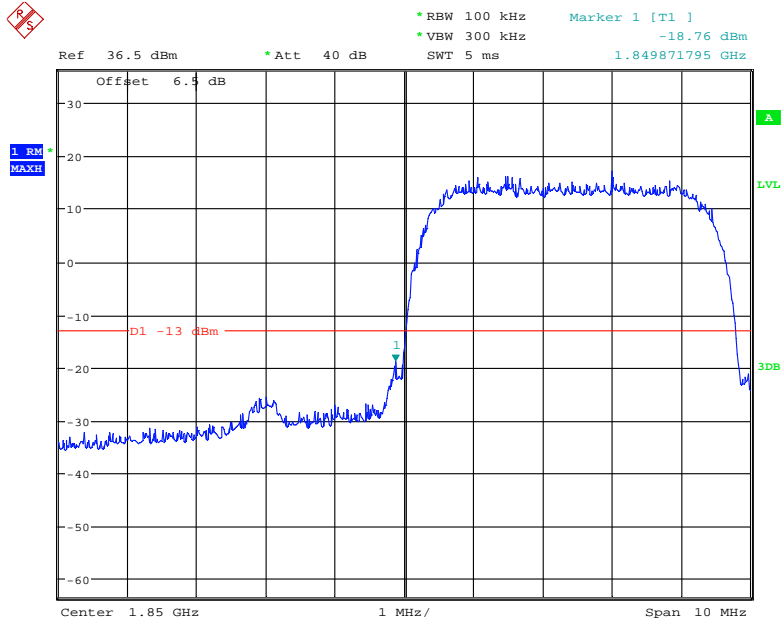

Date: 17.NOV.2020 16:03:06

PCS Band, Right Band Edge for WCDMA (BPSK) Mode

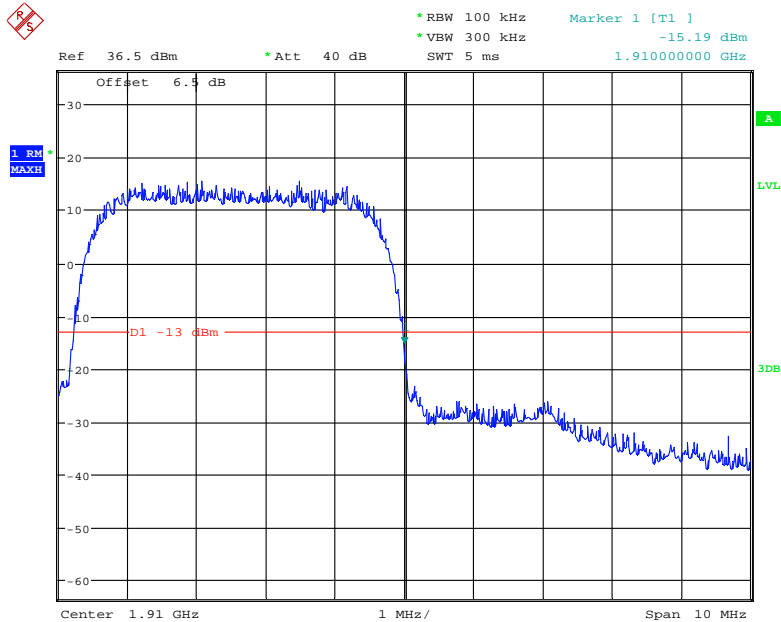

Date: 17.NOV.2020 16:04:11

PCS Band, Left Band Edge for HSDPA (16QAM) Mode

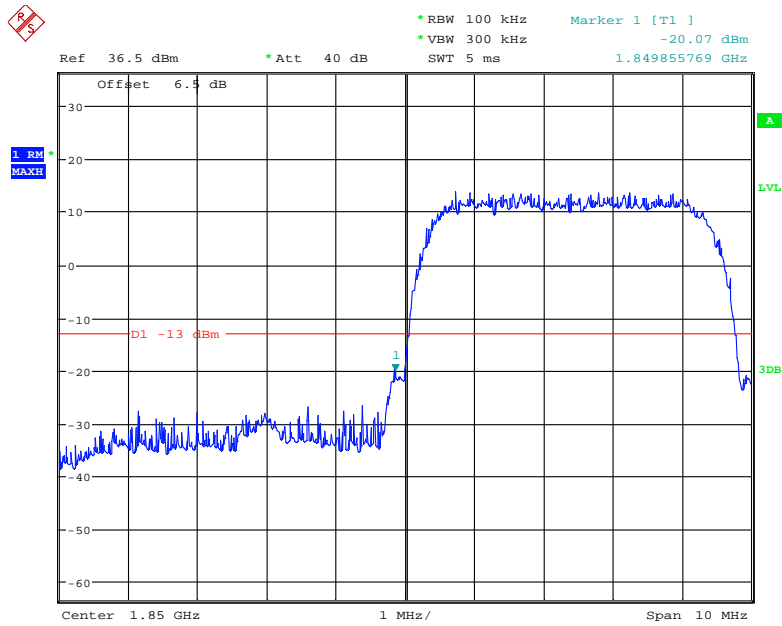

Date: 17.NOV.2020 16:13:38

PCS Band, Right Band Edge for HSDPA (16QAM) Mode

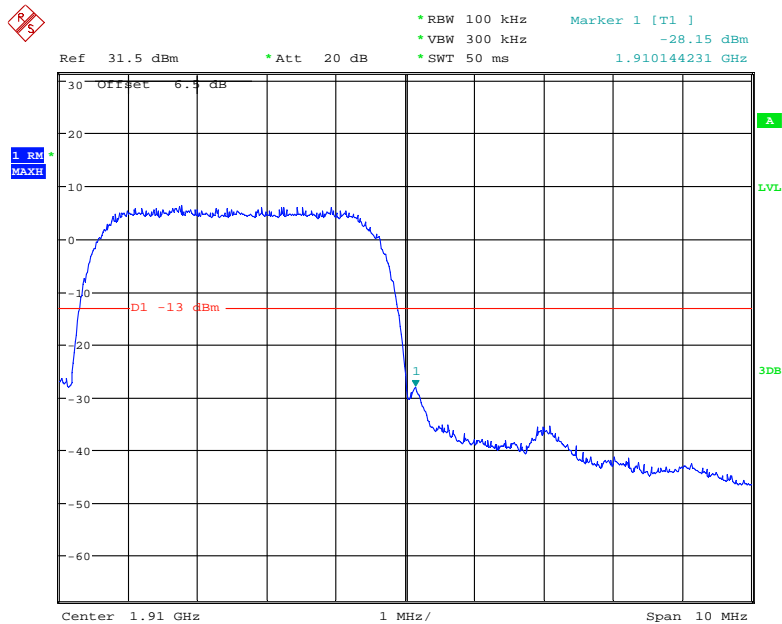

Date: 23.NOV.2020 11:31:01

PCS Band, Left Band Edge for HSUPA (BPSK) Mode

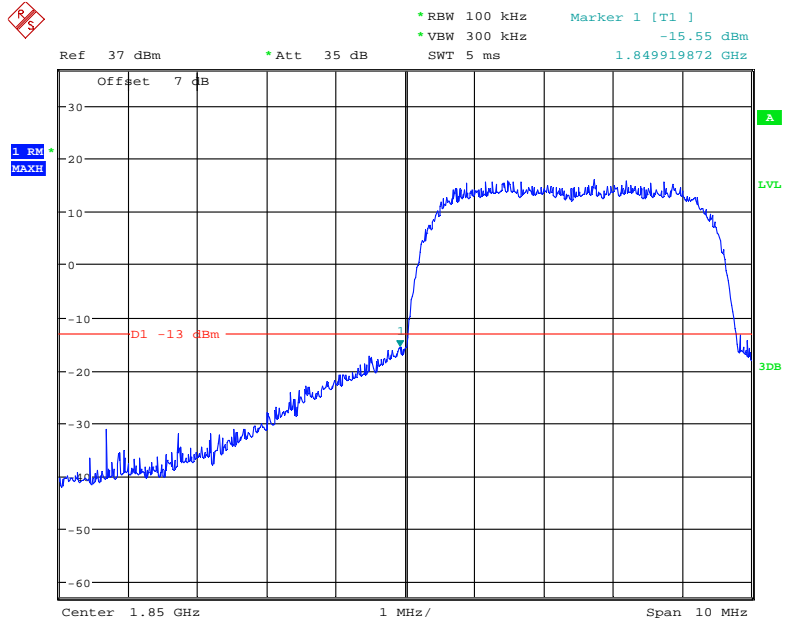

Date: 25.NOV.2020 10:00:26

PCS Band, Right Band Edge for HSUPA (BPSK) Mode

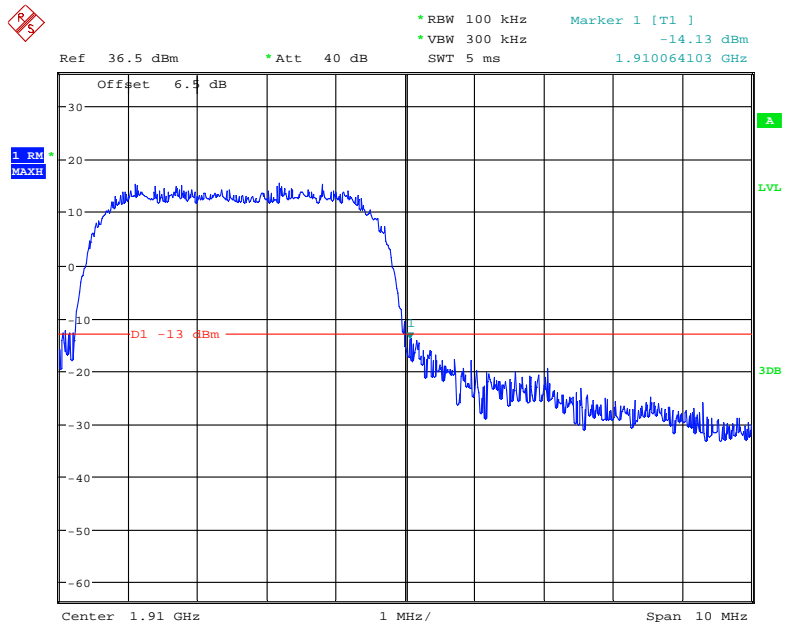

Date: 17.NOV.2020 16:15:16

AWS Band, Left Band Edge for WCDMA (BPSK) Mode

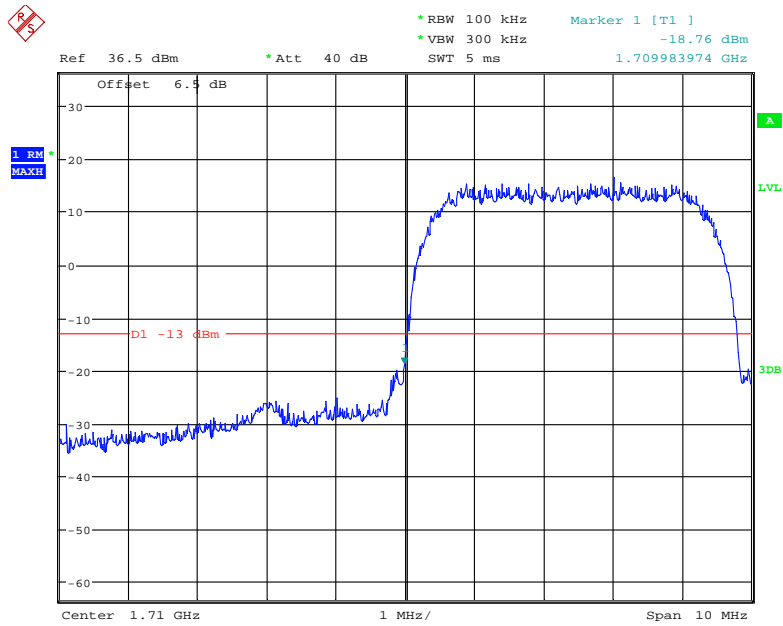

Date: 17.NOV.2020 15:53:47

AWS Band, Right Band Edge for WCDMA (BPSK) Mode

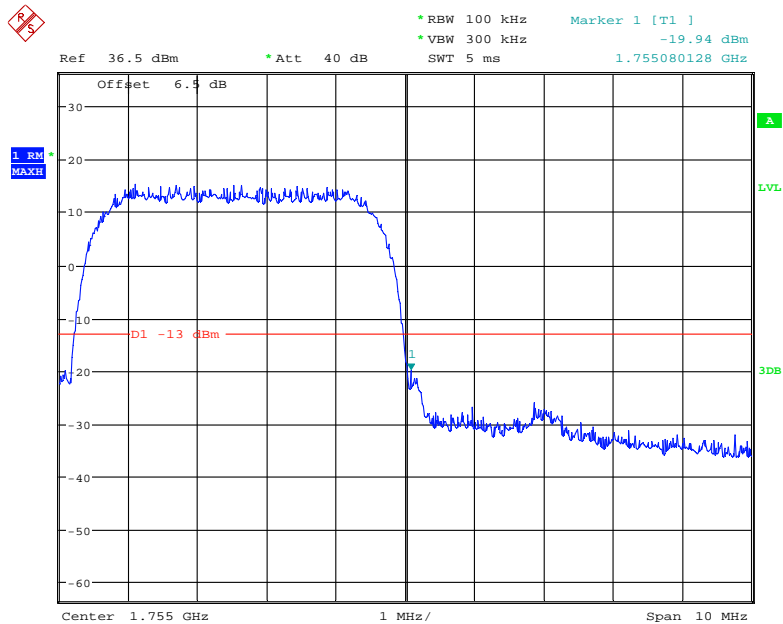

Date: 17.NOV.2020 15:54:26

AWS Band, Left Band Edge for HSDPA (16QAM) Mode

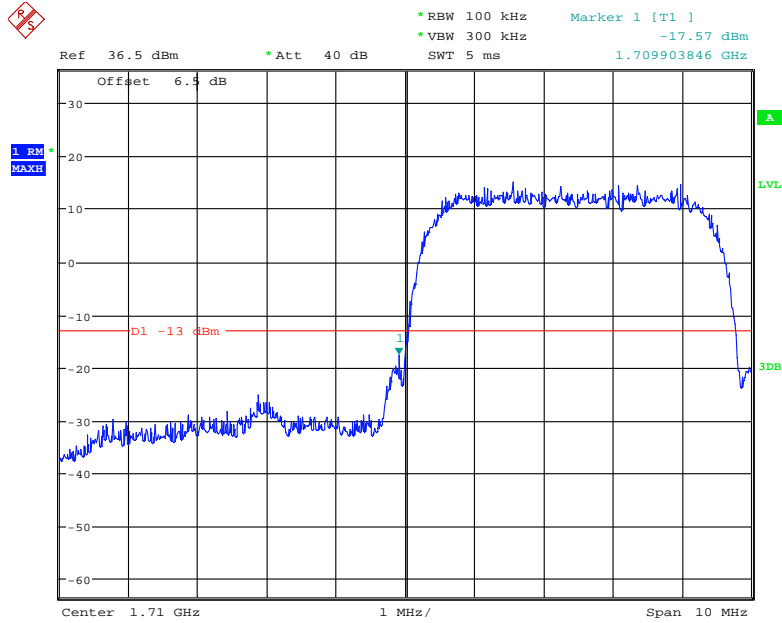

Date: 17.NOV.2020 16:00:55

AWS Band, Right Band Edge for HSDPA (16QAM) Mode

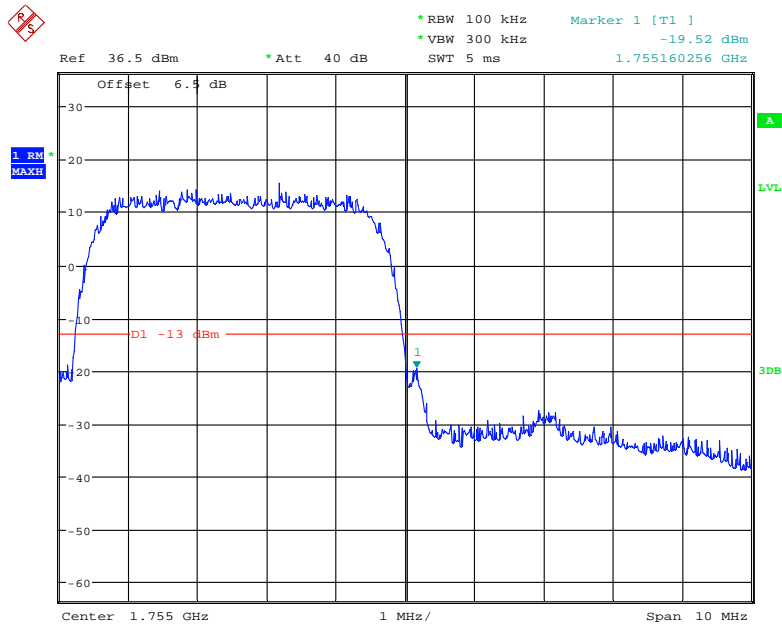

Date: 17.NOV.2020 16:01:37

AWS Band, Left Band Edge for HSUPA (BPSK) Mode

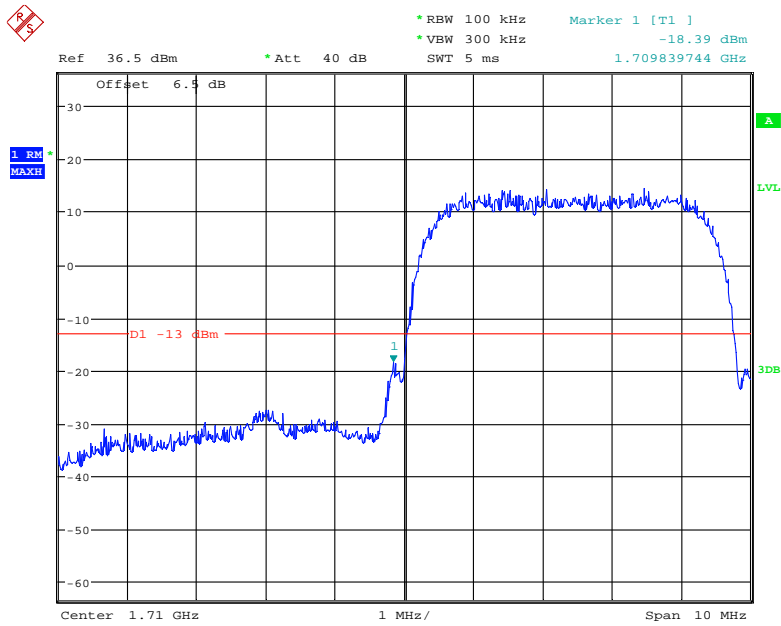

Date: 17.NOV.2020 15:56:15

AWS Band, Right Band Edge for HSUPA (BPSK) Mode

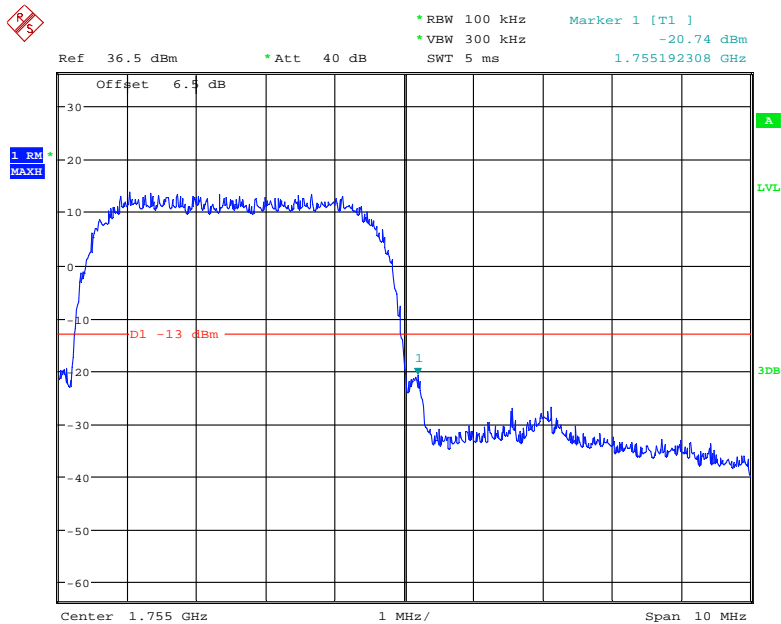

Date: 17.NOV.2020 15:55:05

LTE Band 2:

QPSK (1.4 MHz, FULL RB) - Left Band Edge

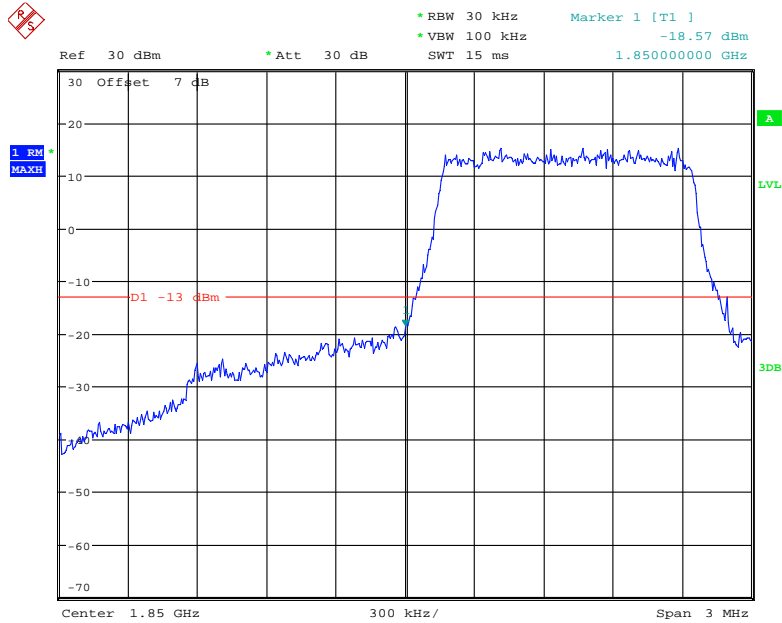

Date: 18.NOV.2020 14:42:33

QPSK (1.4 MHz, FULL RB) - Right Band Edge

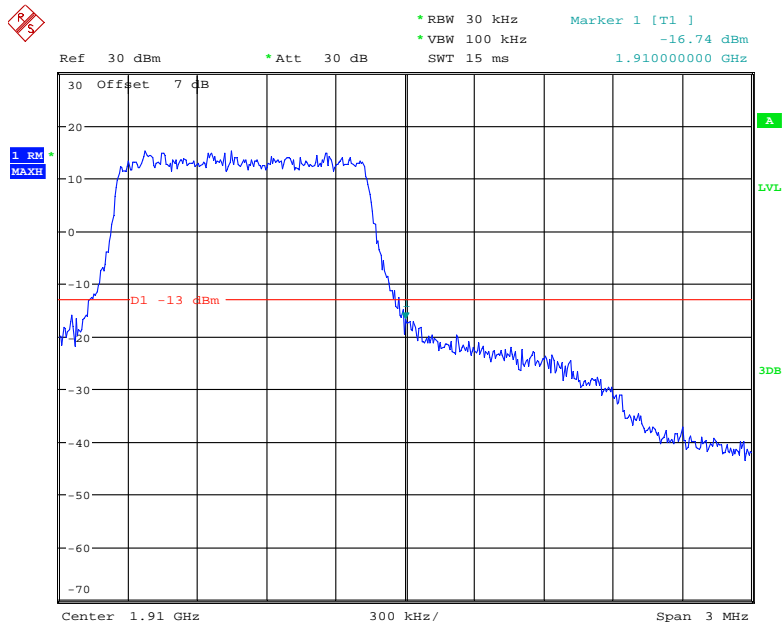

Date: 18.NOV.2020 14:43:14

16-QAM (1.4 MHz, FULL RB) - Left Band Edge

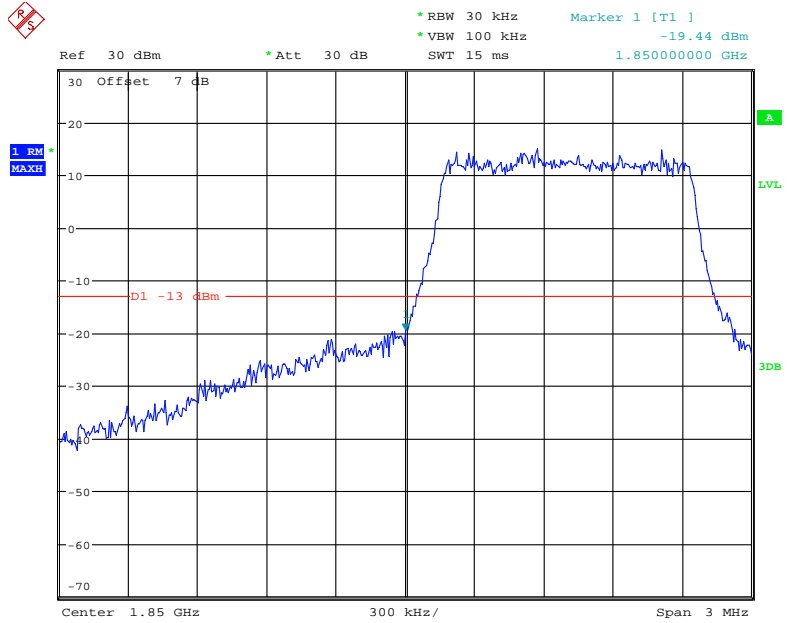

Date: 18.NOV.2020 14:42:53

16-QAM (1.4 MHz, FULL RB) - Right Band Edge

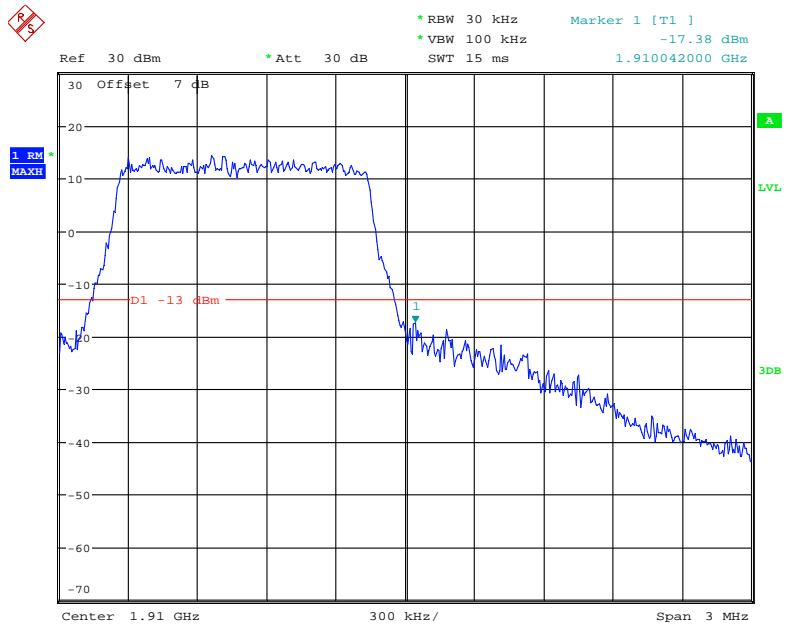

Date: 18.NOV.2020 14:43:33

QPSK (3.0 MHz, FULL RB) - Left Band Edge

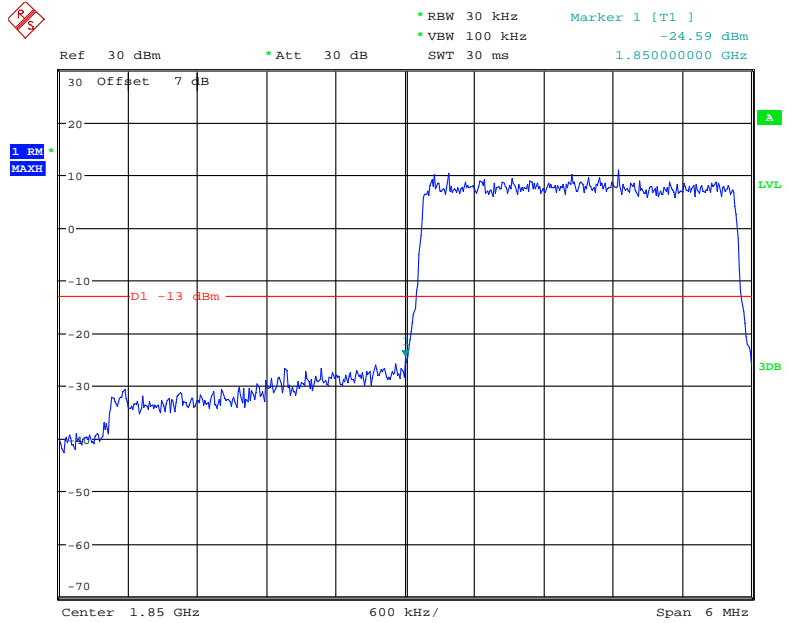

Date: 18.NOV.2020 14:43:52

QPSK (3.0 MHz, FULL RB) - Right Band Edge

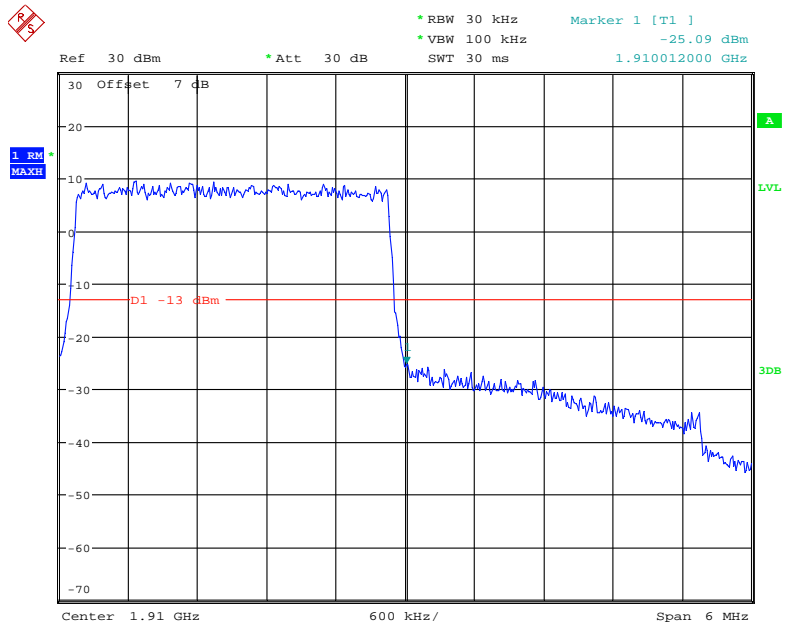

Date: 18.NOV.2020 14:44:26

16-QAM (3.0 MHz, FULL RB) - Left Band Edge

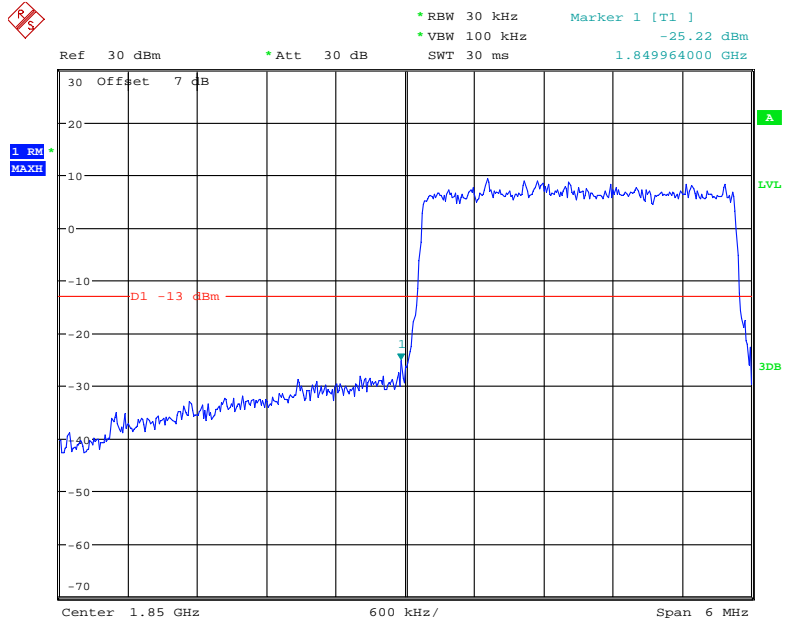

Date: 18.NOV.2020 14:44:08

16-QAM (3.0 MHz, FULL RB) - Right Band Edge

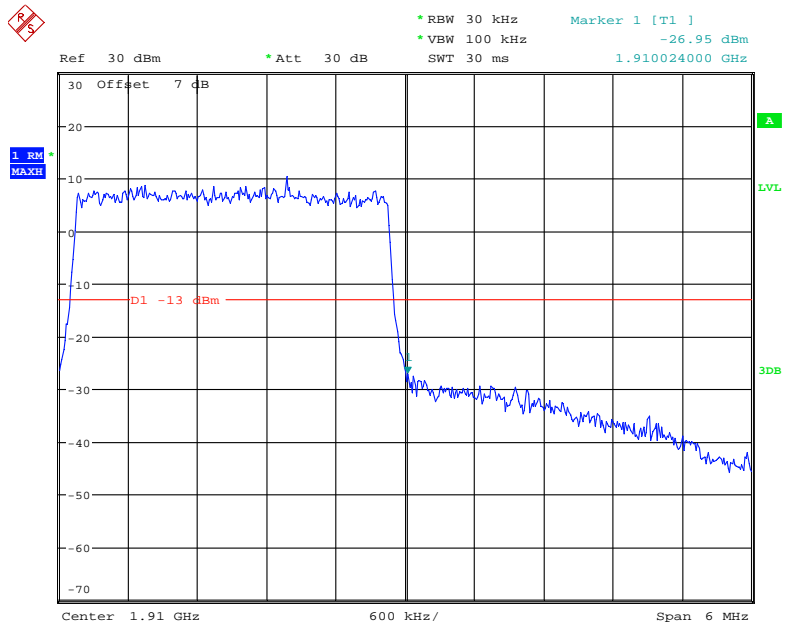

Date: 18.NOV.2020 14:44:42

QPSK (5.0 MHz, FULL RB) - Left Band Edge

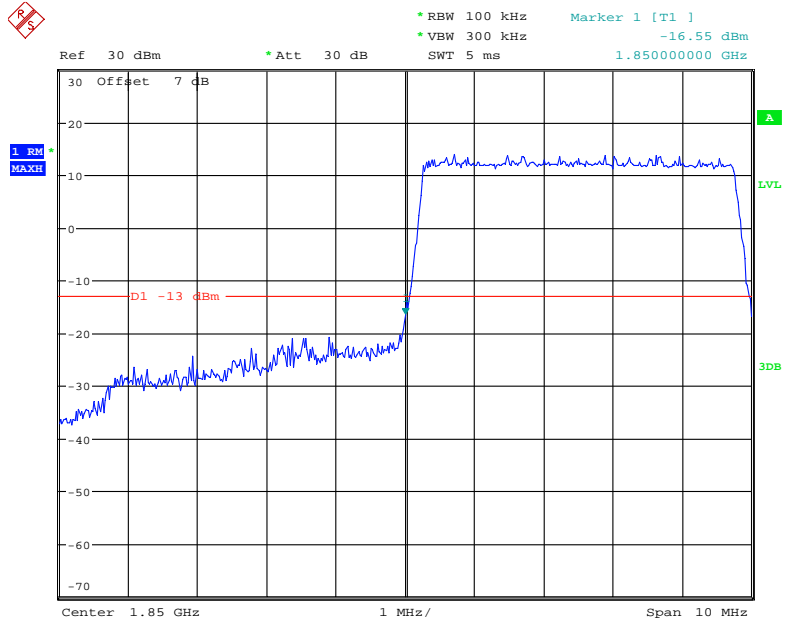

Date: 18.NOV.2020 14:45:03

QPSK (5.0 MHz, FULL RB) - Right Band Edge

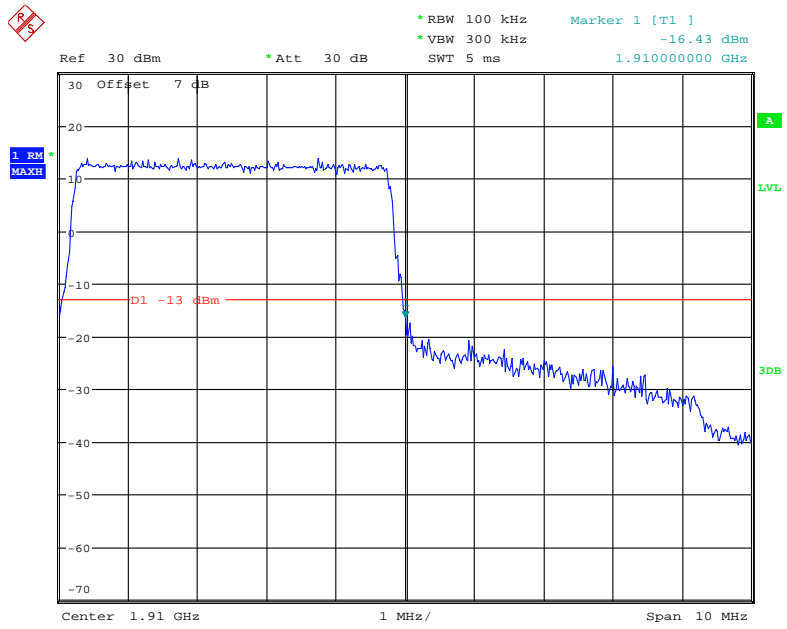

Date: 18.NOV.2020 14:45:42

16-QAM (5.0 MHz, FULL RB) - Left Band Edge

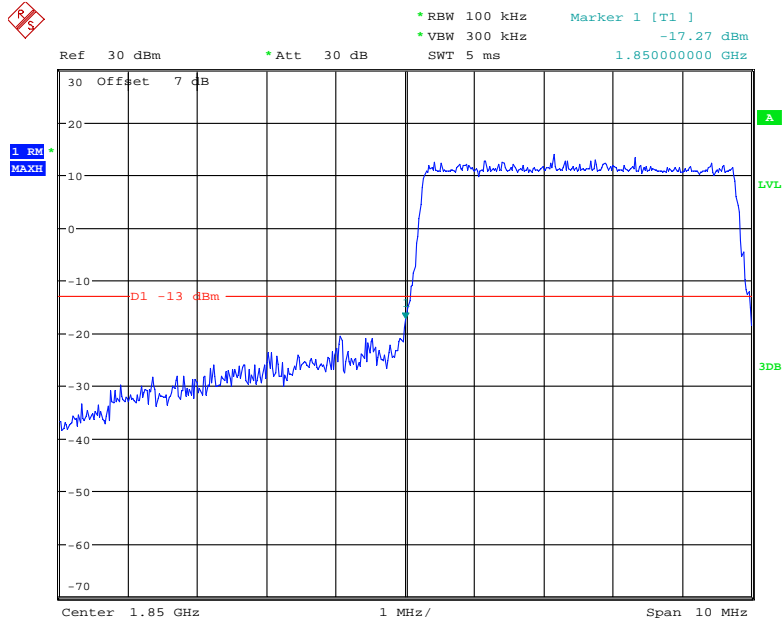

Date: 18.NOV.2020 14:45:20

16-QAM (5.0 MHz, FULL RB) - Right Band Edge

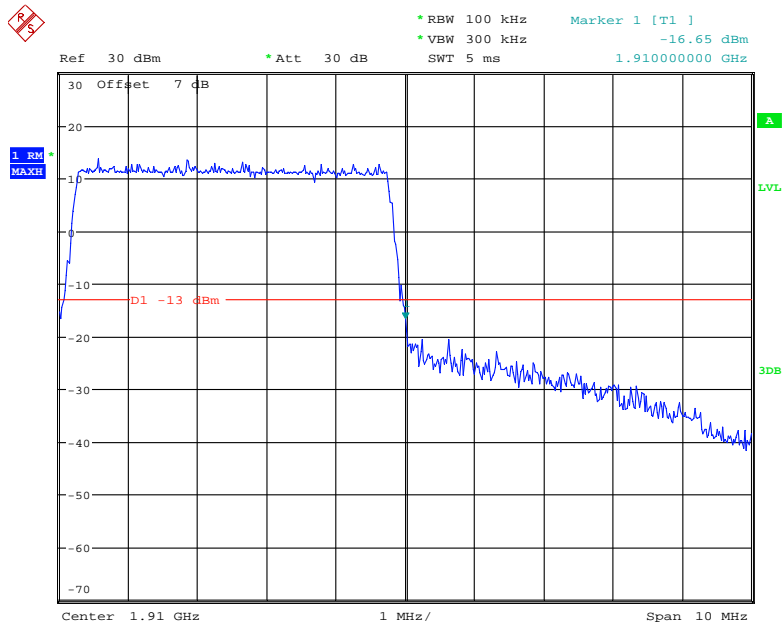

Date: 18.NOV.2020 14:46:03

QPSK (10.0 MHz, FULL RB) - Left Band Edge

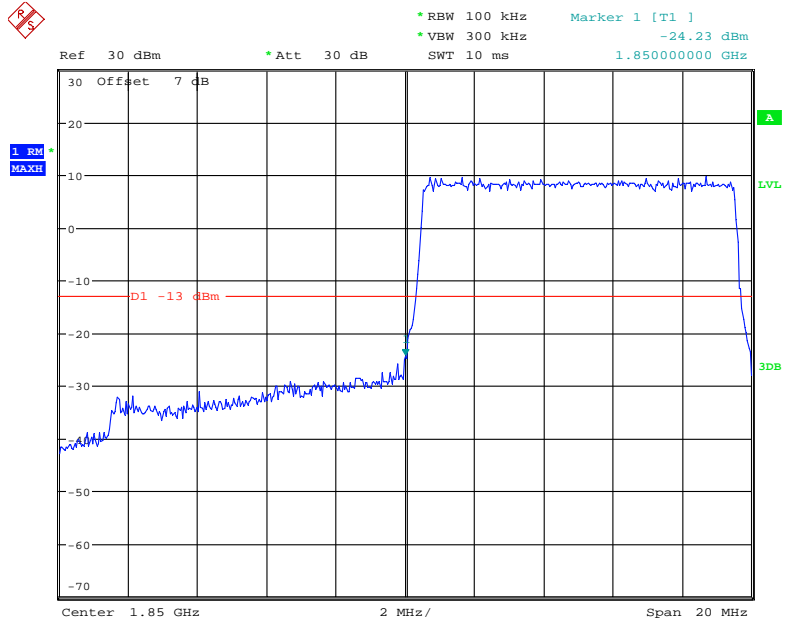

Date: 18.NOV.2020 14:46:23

QPSK (10.0 MHz, FULL RB) - Right Band Edge

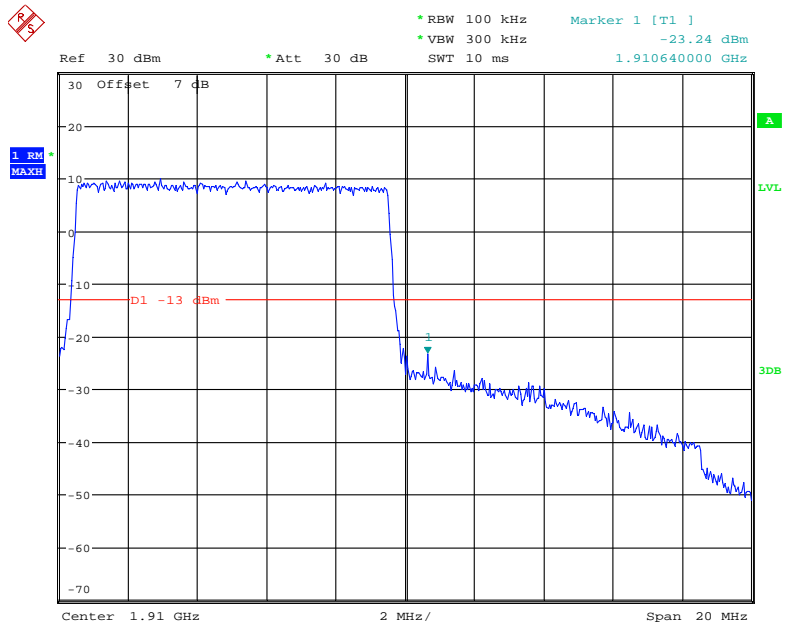

Date: 18.NOV.2020 14:47:02

16-QAM (10.0 MHz, FULL RB) - Left Band Edge

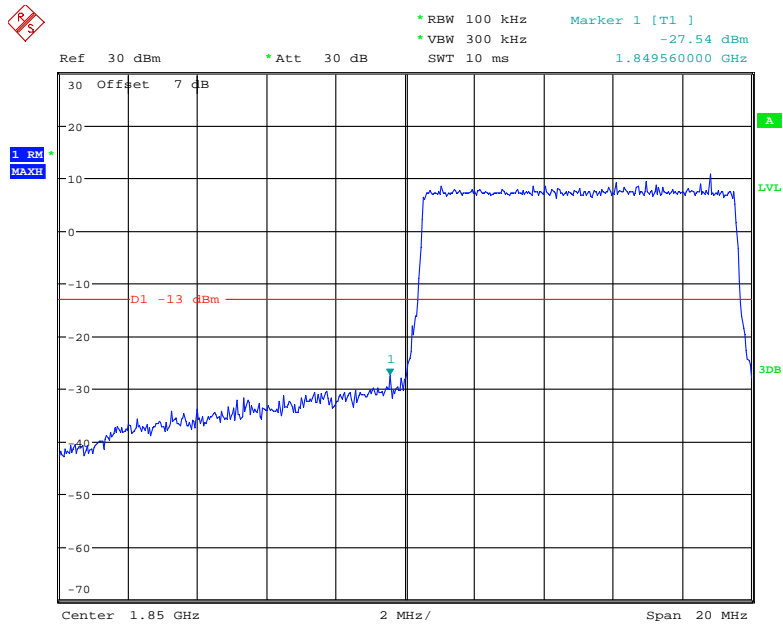

Date: 18.NOV.2020 14:46:44

16-QAM (10.0 MHz, FULL RB) - Right Band Edge

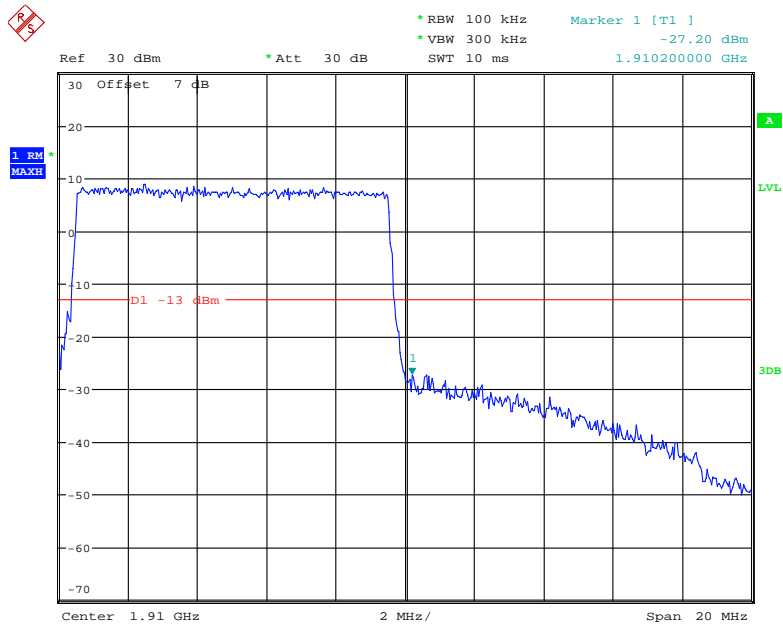

Date: 18.NOV.2020 14:47:20

QPSK (15.0 MHz, FULL RB) - Left Band Edge

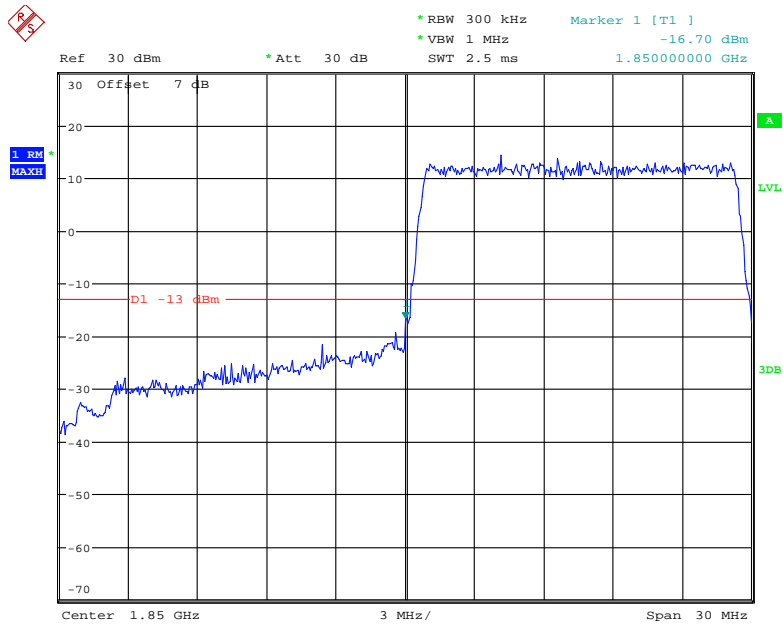

Date: 18.NOV.2020 14:47:43

QPSK (15.0 MHz, FULL RB) - Right Band Edge

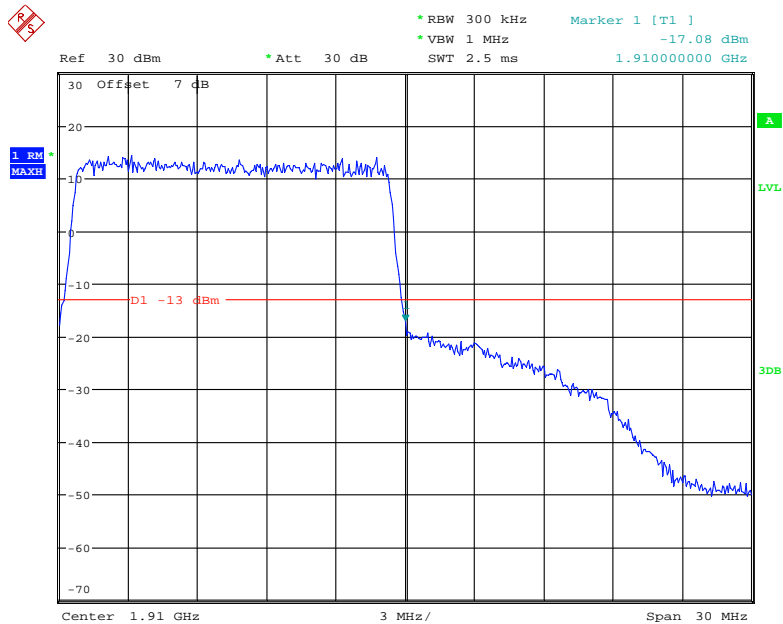

Date: 18.NOV.2020 14:48:29

16-QAM (15.0 MHz, FULL RB) - Left Band Edge

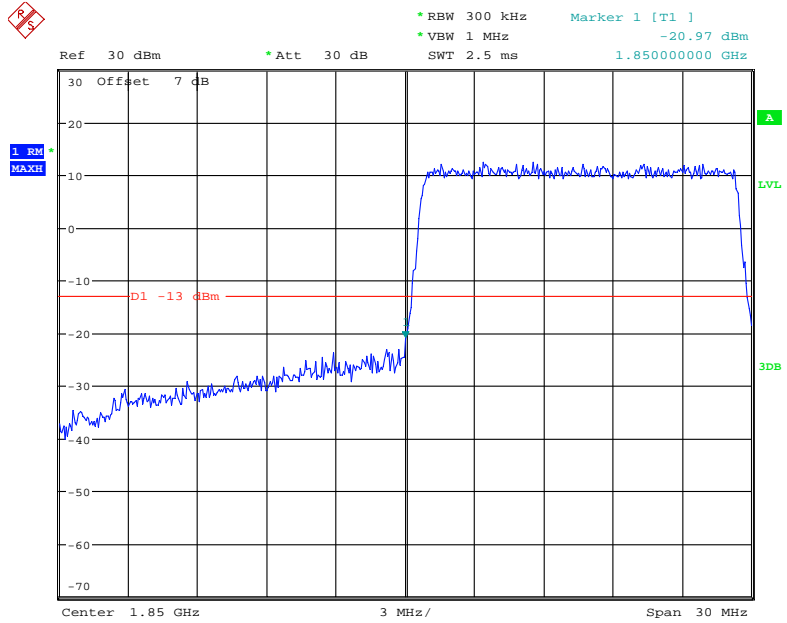

Date: 18.NOV.2020 14:48:04

16-QAM (15.0 MHz, FULL RB) - Right Band Edge

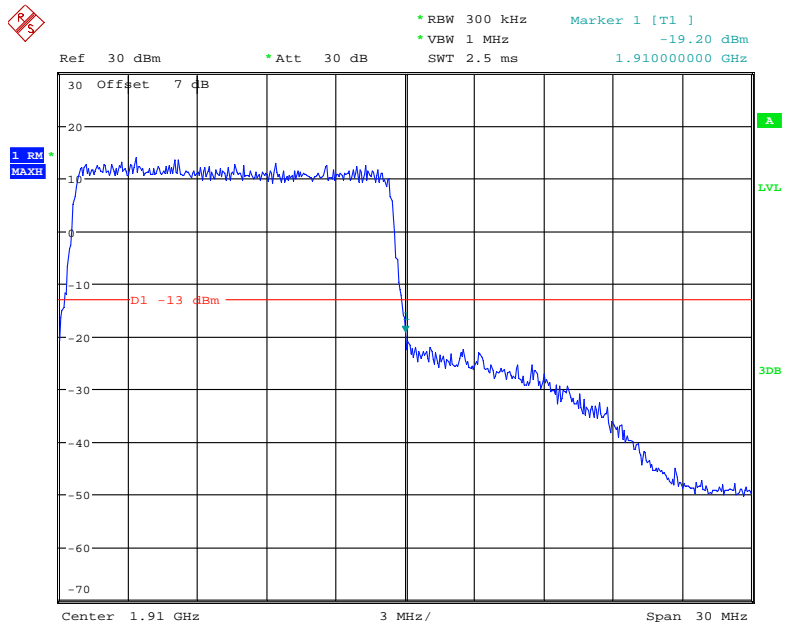

Date: 18.NOV.2020 14:48:53

QPSK (20.0 MHz, FULL RB) - Left Band Edge

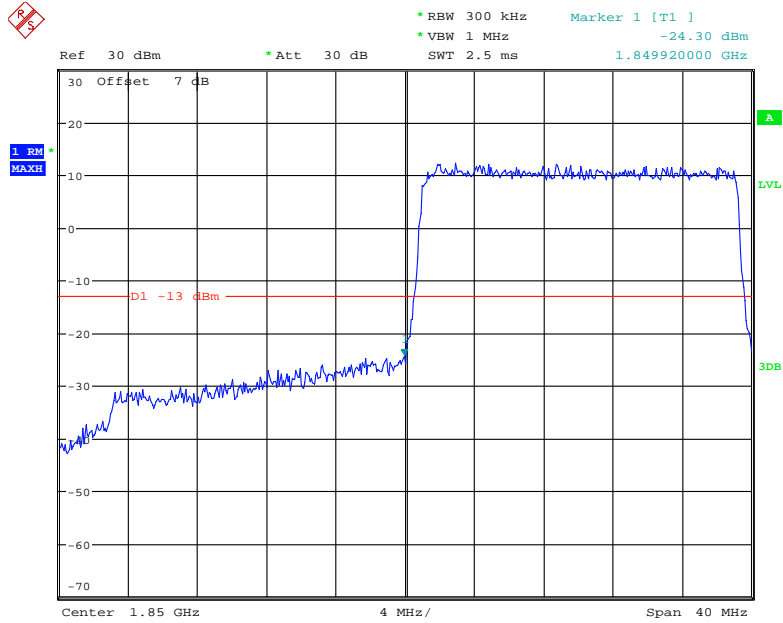

Date: 18.NOV.2020 14:49:17

QPSK (20.0 MHz, FULL RB) - Right Band Edge

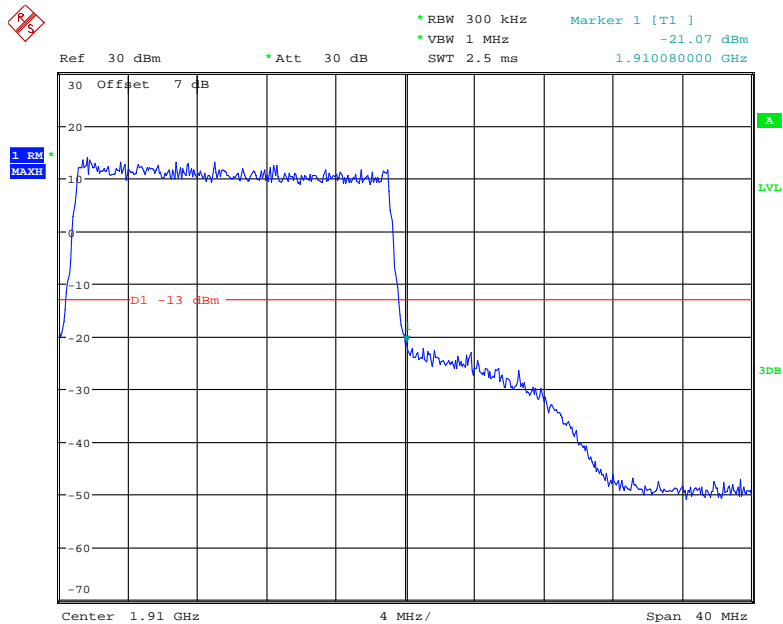

Date: 18.NOV.2020 14:50:02

16-QAM (20.0 MHz, FULL RB) - Left Band Edge

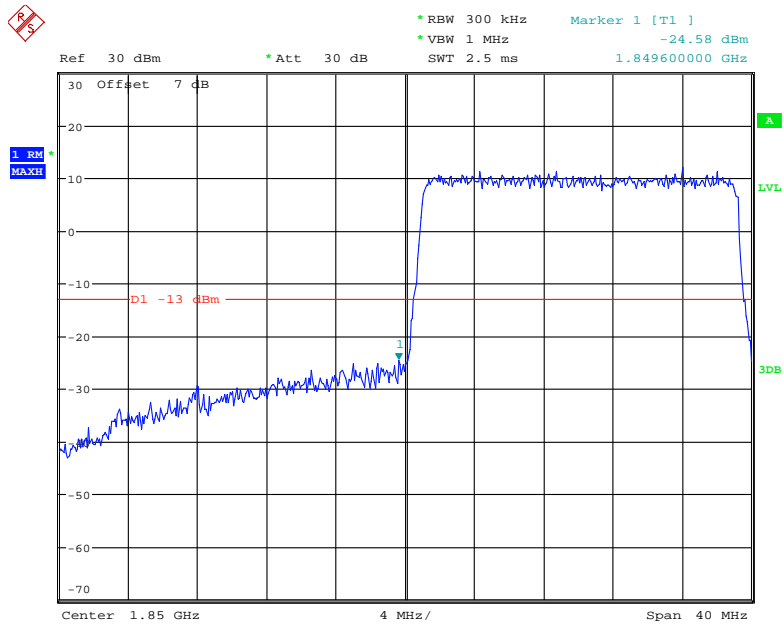

Date: 18.NOV.2020 14:49:38

16-QAM (20.0 MHz, FULL RB) - Right Band Edge

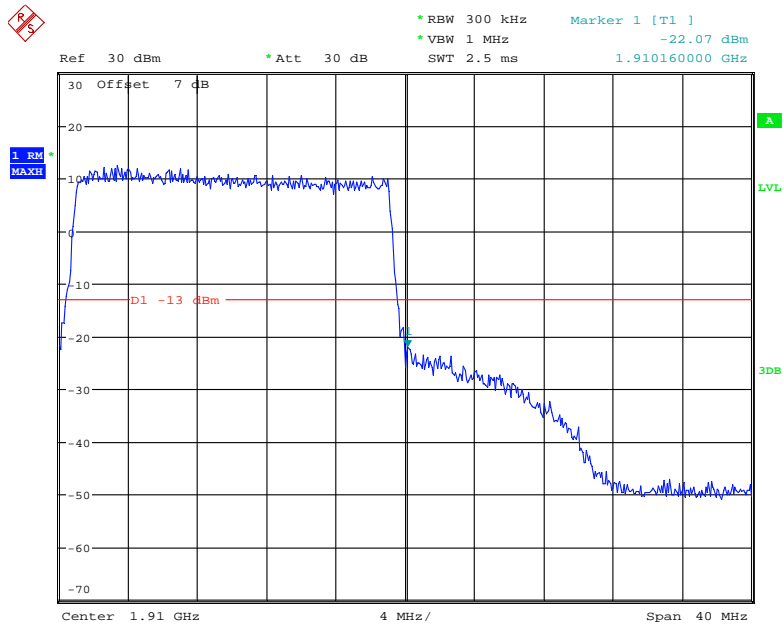

Date: 18.NOV.2020 14:50:23

LTE Band 4:

QPSK (1.4 MHz, FULL RB) - Left Band Edge

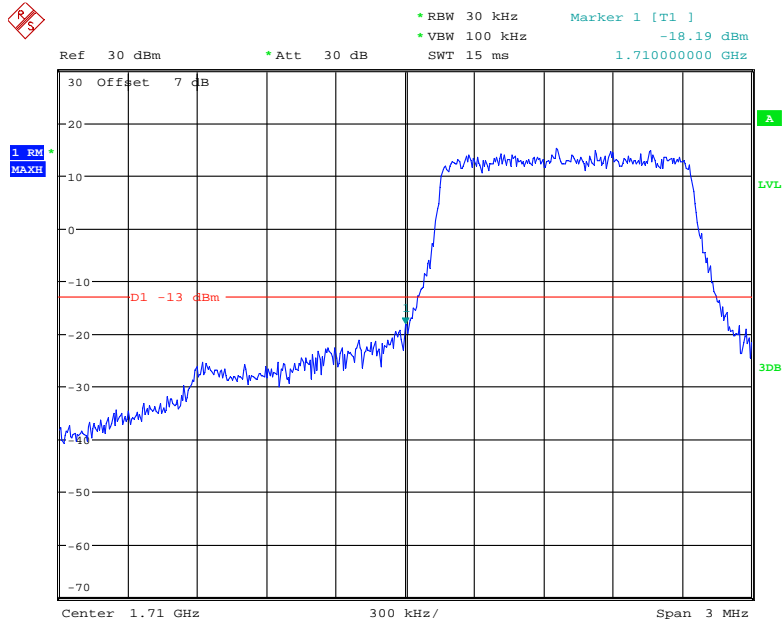

Date: 18.NOV.2020 14:50:49

QPSK (1.4 MHz, FULL RB) - Right Band Edge

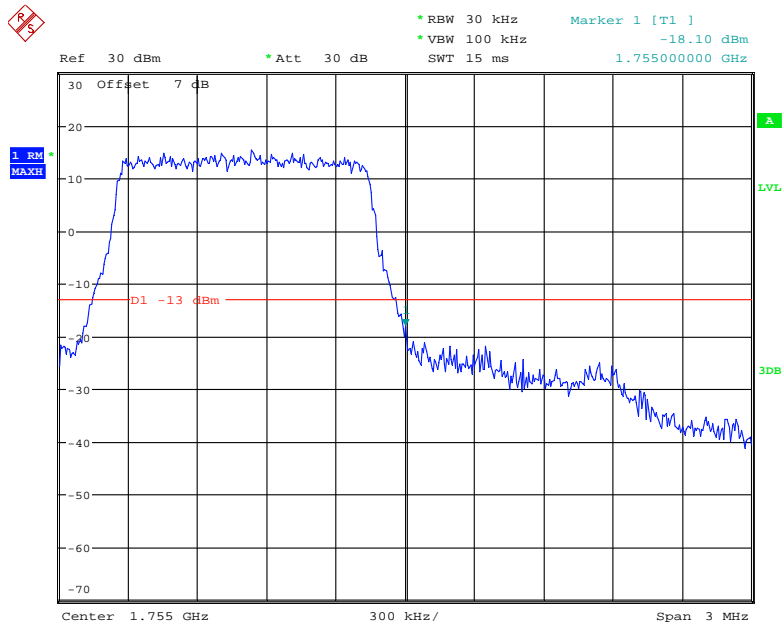

Date: 18.NOV.2020 14:51:29

16-QAM (1.4 MHz, FULL RB) - Left Band Edge

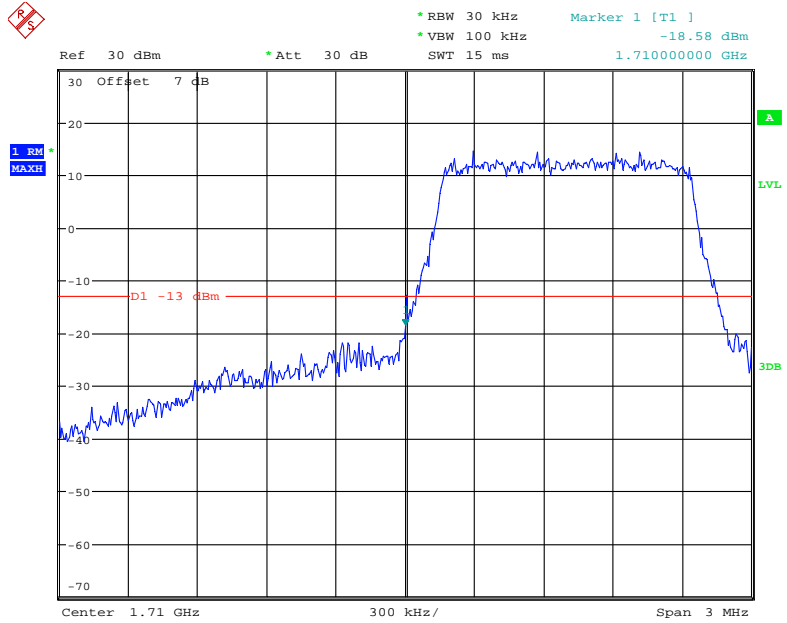

Date: 18.NOV.2020 14:51:11

16-QAM (1.4 MHz, FULL RB) - Right Band Edge

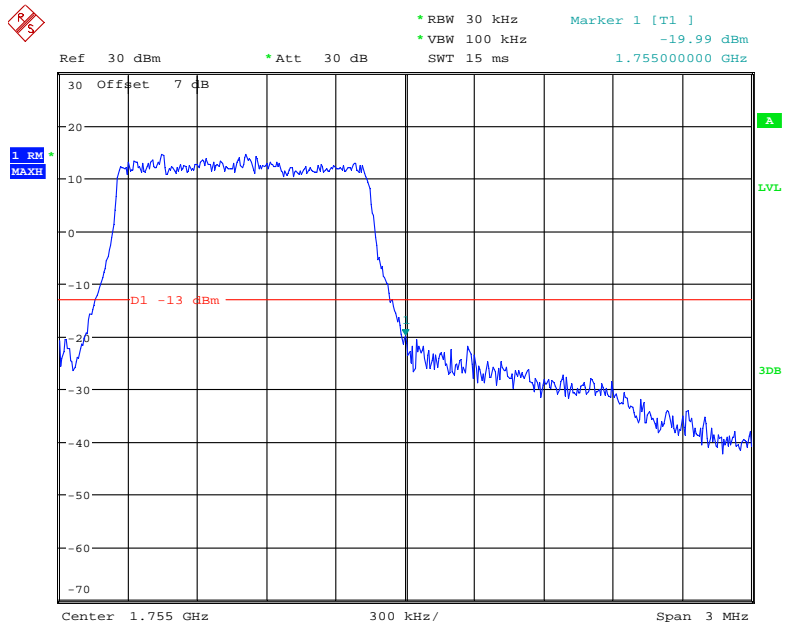

Date: 18.NOV.2020 14:51:45

QPSK (3.0 MHz, FULL RB) - Left Band Edge

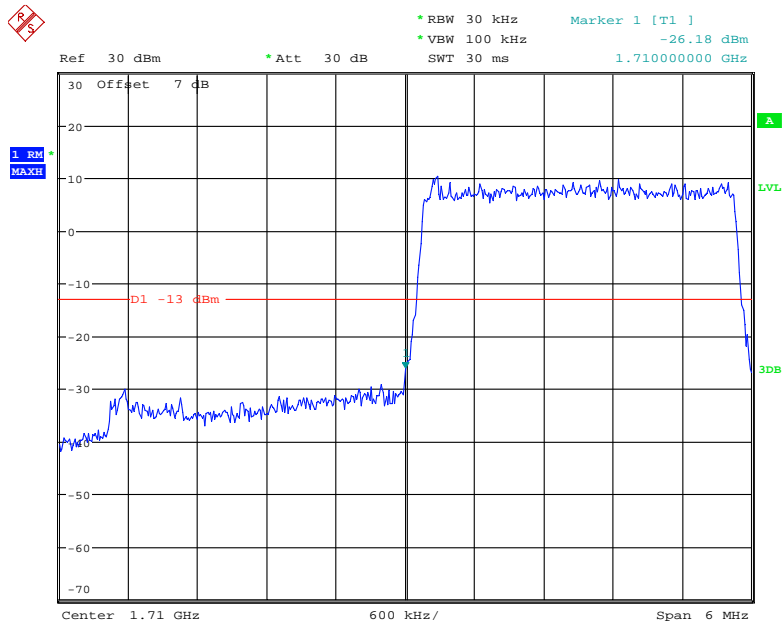

Date: 18.NOV.2020 14:52:04

QPSK (3.0 MHz, FULL RB) - Right Band Edge

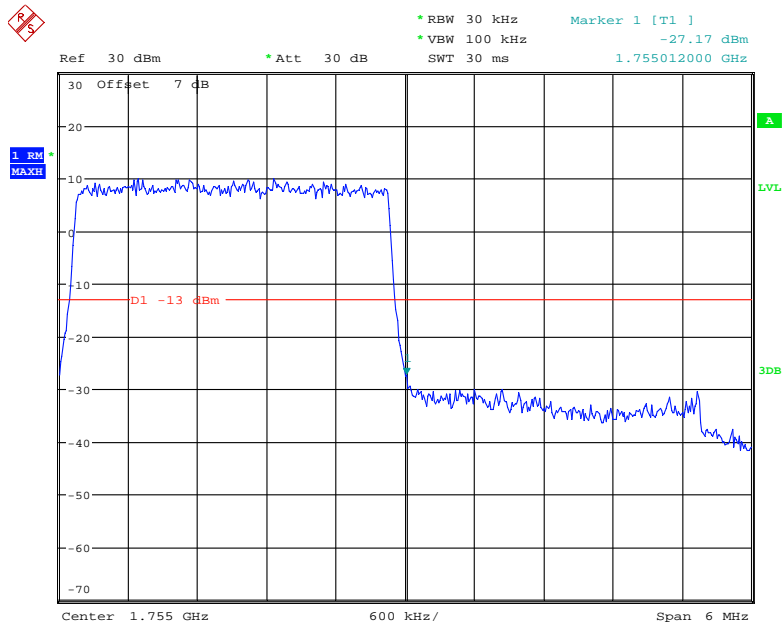

Date: 18.NOV.2020 14:52:38

16-QAM (3.0 MHz, FULL RB) - Left Band Edge

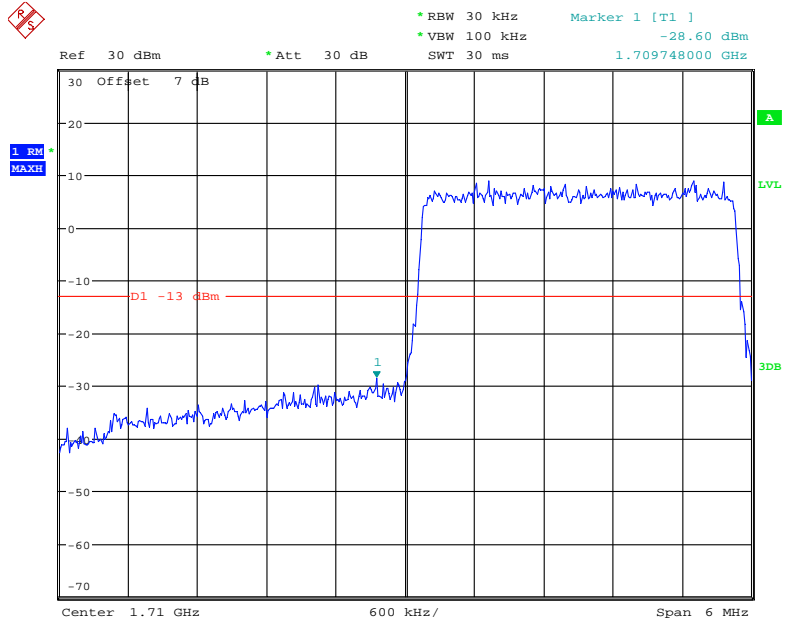

Date: 18.NOV.2020 14:52:21

16-QAM (3.0 MHz, FULL RB) - Right Band Edge

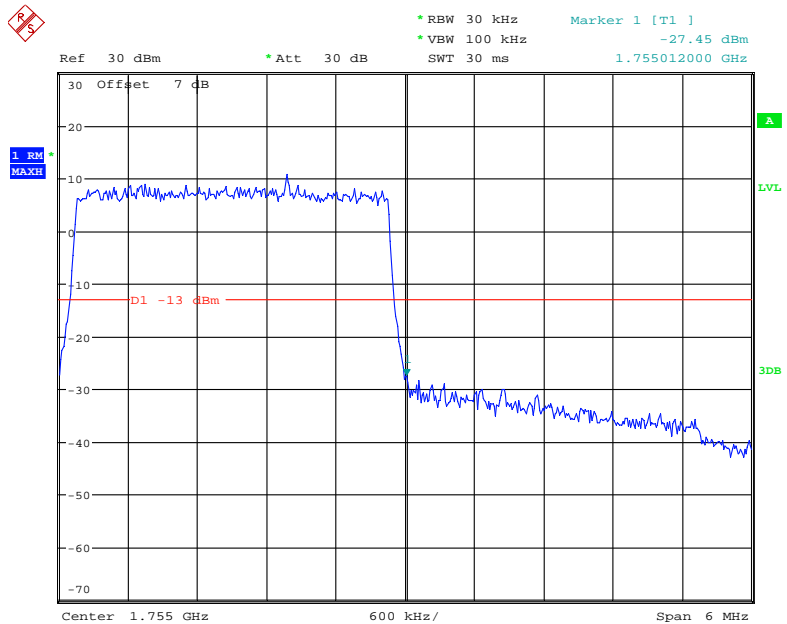

Date: 18.NOV.2020 14:52:55

QPSK (5.0 MHz, FULL RB) - Left Band Edge

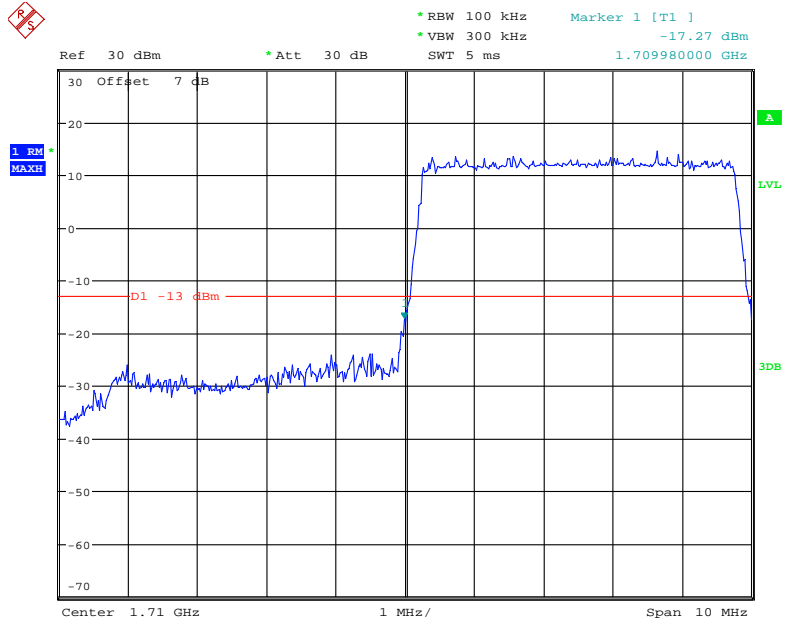

Date: 18.NOV.2020 14:53:18

QPSK (5.0 MHz, FULL RB) - Right Band Edge

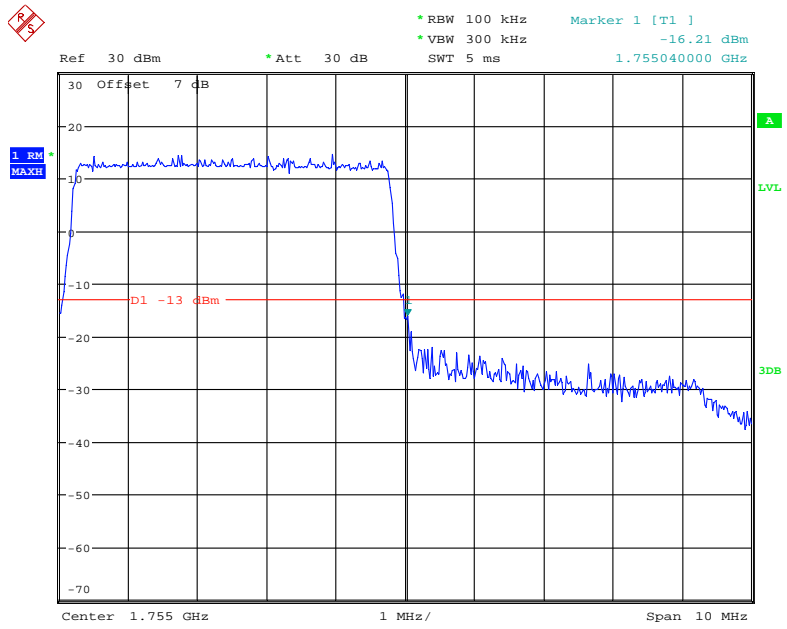

Date: 18.NOV.2020 14:53:58

16-QAM (5.0 MHz, FULL RB) - Left Band Edge

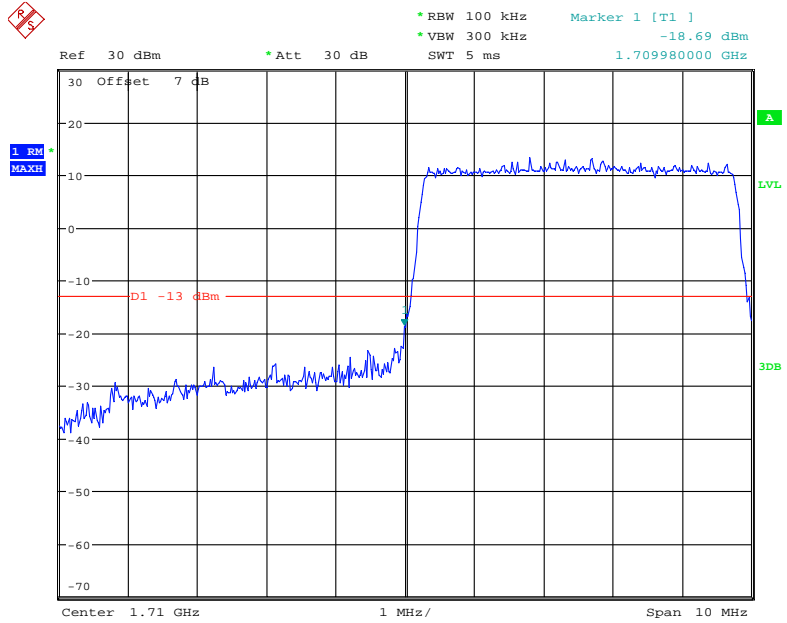

Date: 18.NOV.2020 14:53:37

16-QAM (5.0 MHz, FULL RB) - Right Band Edge

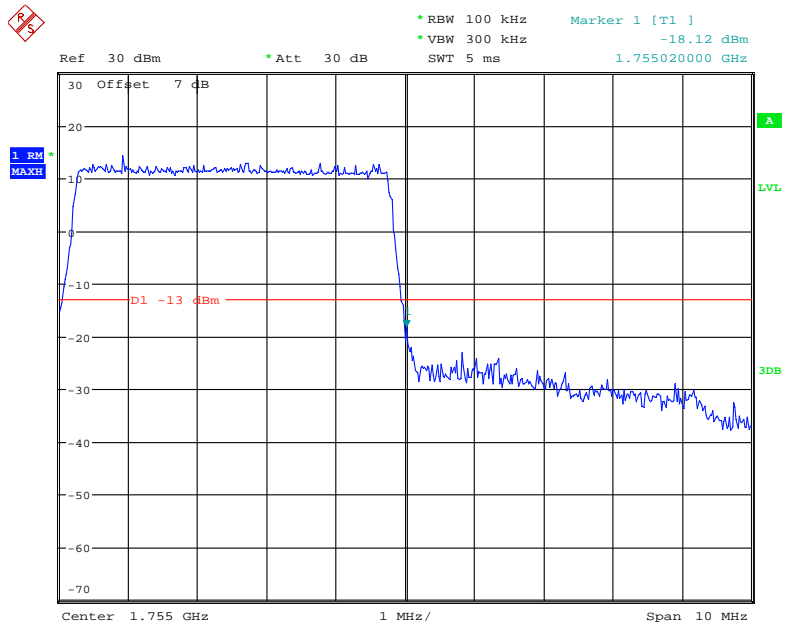

Date: 18.NOV.2020 14:54:19

QPSK (10.0 MHz, FULL RB) - Left Band Edge

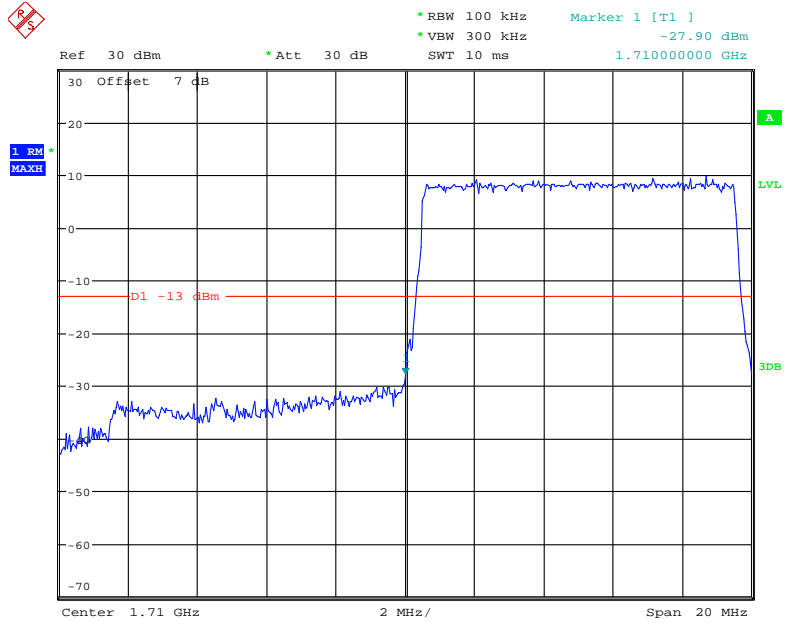

Date: 18.NOV.2020 14:54:39

QPSK (10.0 MHz, FULL RB) - Right Band Edge

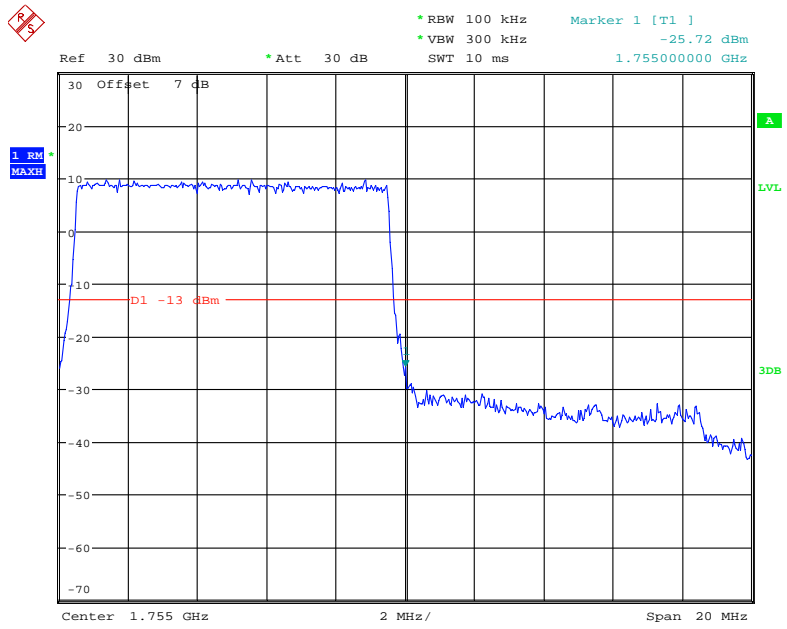

Date: 18.NOV.2020 14:55:15

16-QAM (10.0 MHz, FULL RB) - Left Band Edge

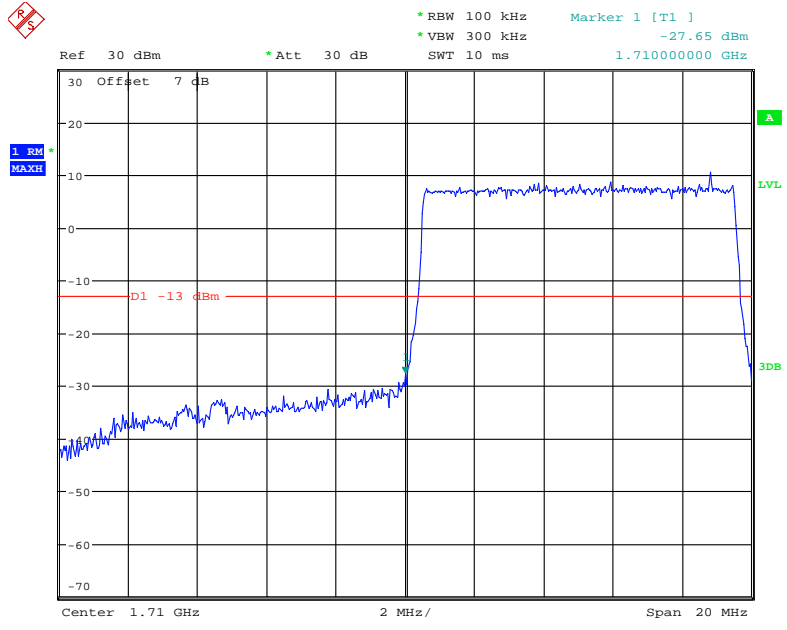

Date: 18.NOV.2020 14:54:56

16-QAM (10.0 MHz, FULL RB) - Right Band Edge

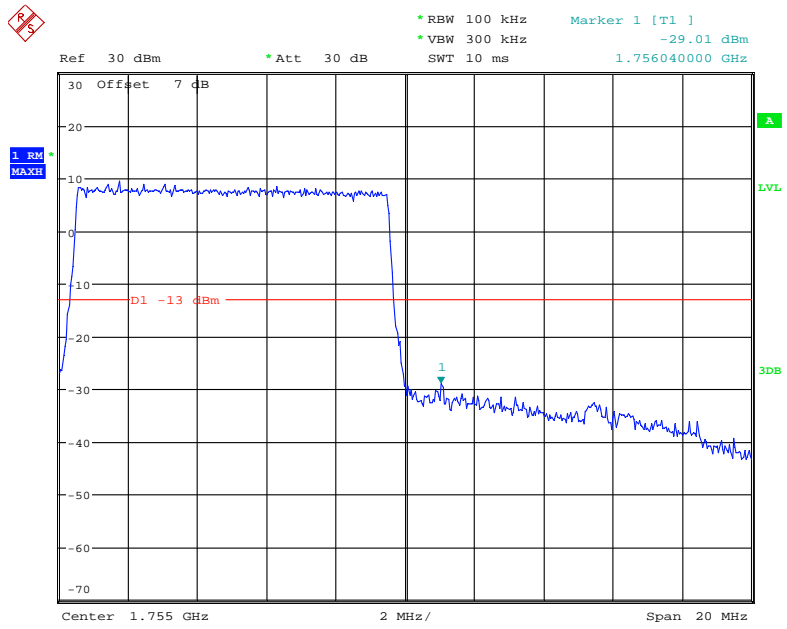

Date: 18.NOV.2020 14:55:32

QPSK (15.0 MHz, FULL RB) - Left Band Edge

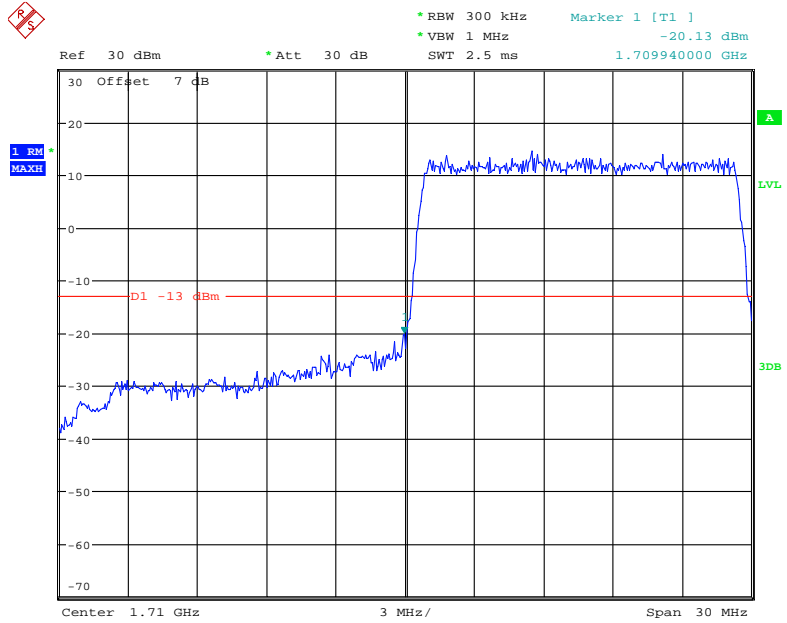

Date: 18.NOV.2020 14:55:59

QPSK (15.0 MHz, FULL RB) - Right Band Edge

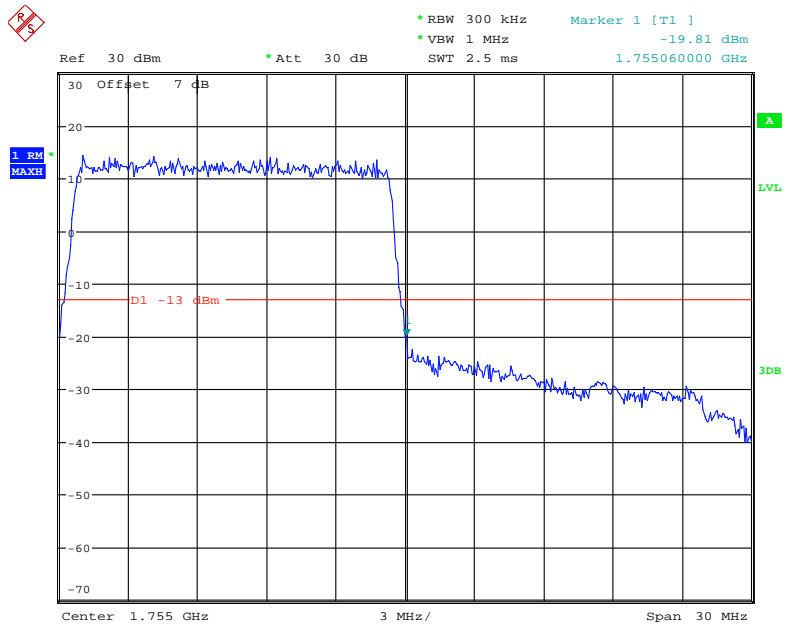

Date: 18.NOV.2020 14:56:42

16-QAM (15.0 MHz, FULL RB) - Left Band Edge

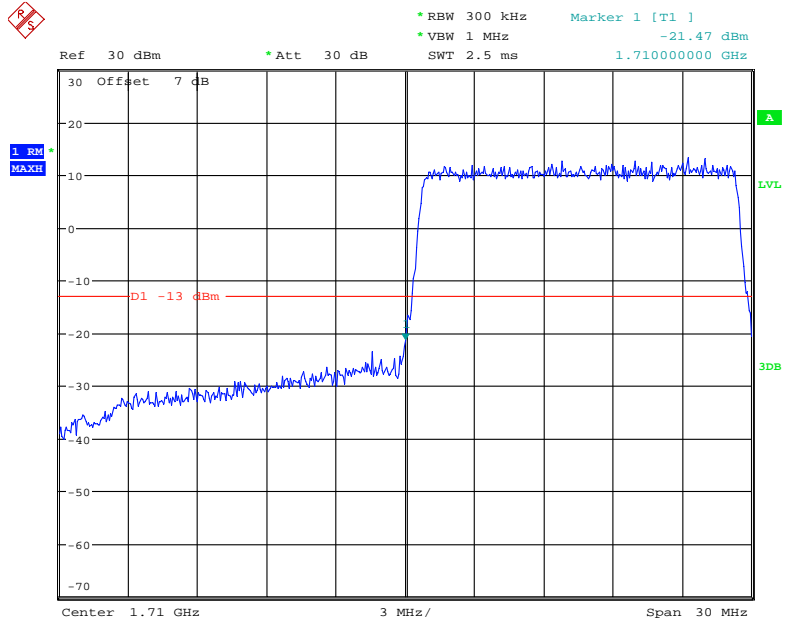

Date: 18.NOV.2020 14:56:20

16-QAM (15.0 MHz, FULL RB) - Right Band Edge

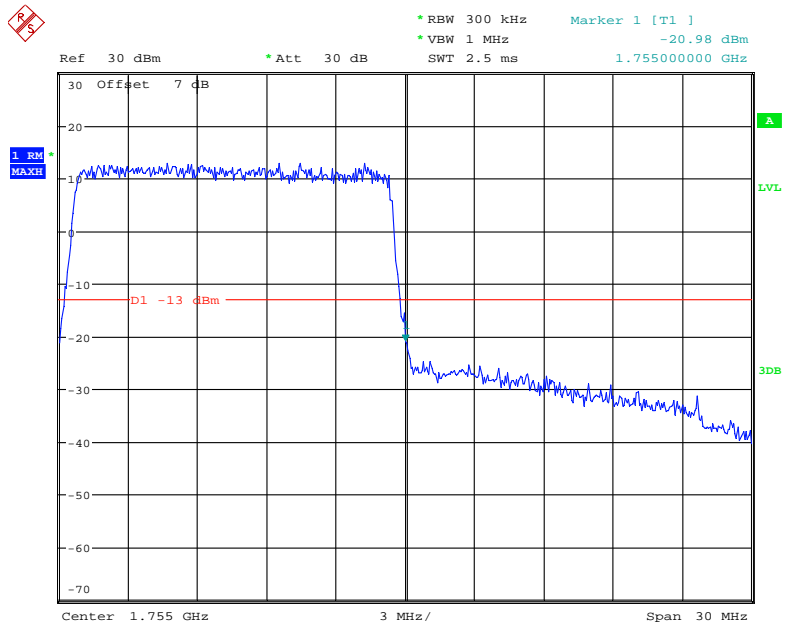

Date: 18.NOV.2020 14:57:06

QPSK (20.0 MHz, FULL RB) - Left Band Edge

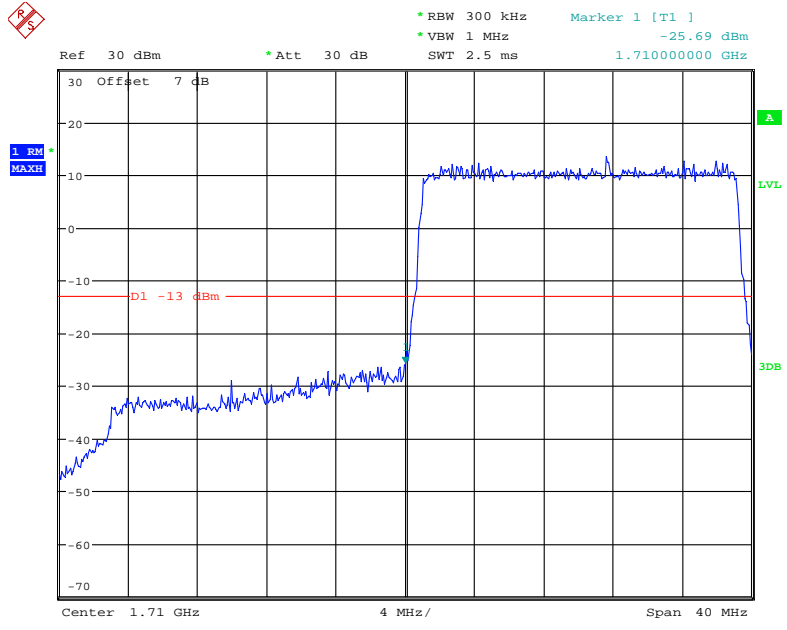

Date: 18.NOV.2020 14:57:30

QPSK (20.0 MHz, FULL RB) - Right Band Edge

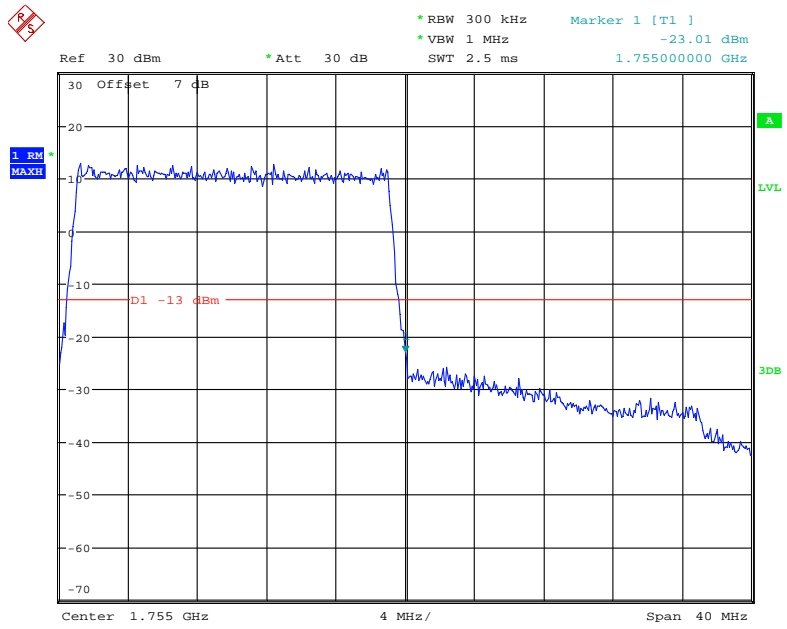

Date: 18.NOV.2020 14:58:13

16-QAM (20.0 MHz, FULL RB) - Left Band Edge

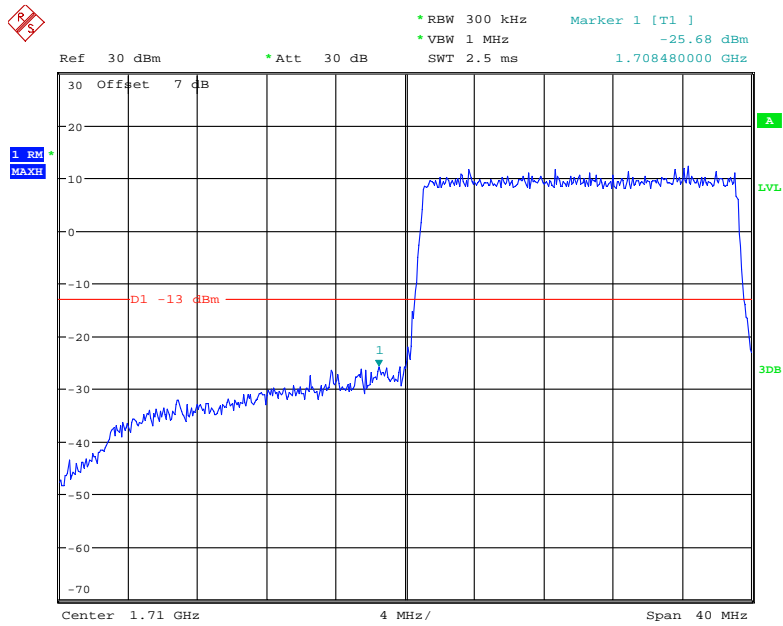

Date: 18.NOV.2020 14:57:51

16-QAM (20.0 MHz, FULL RB) - Right Band Edge

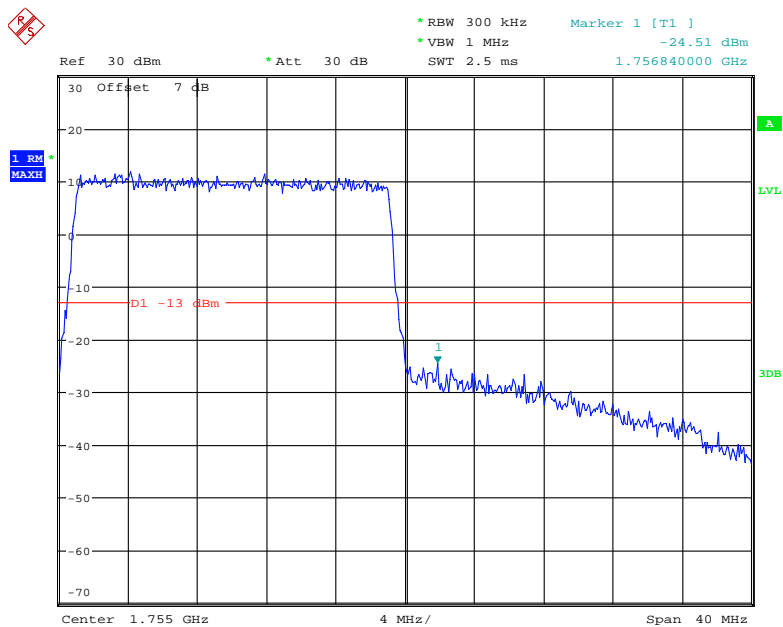

Date: 18.NOV.2020 14:58:33

LTE Band 5:

QPSK (1.4 MHz, FULL RB) - Left Band Edge

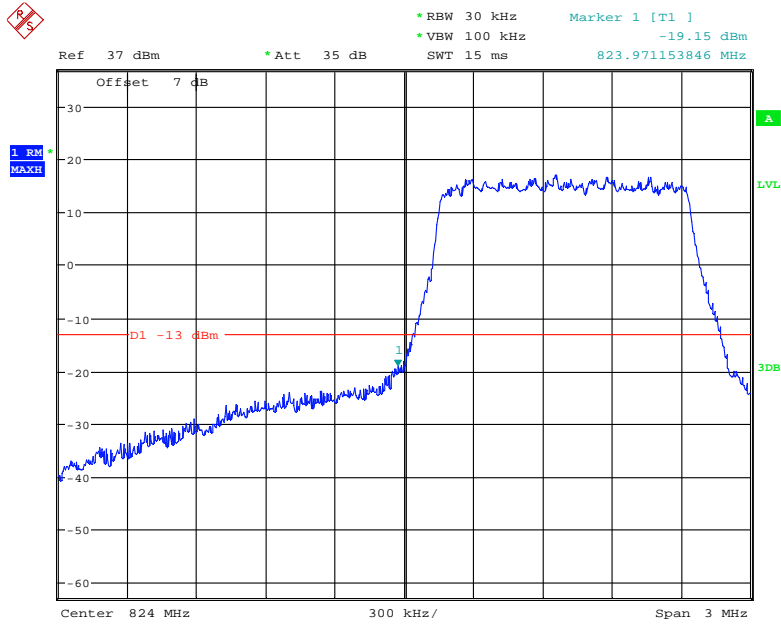

Date: 25.NOV.2020 12:13:56

QPSK (1.4 MHz, FULL RB) - Right Band Edge

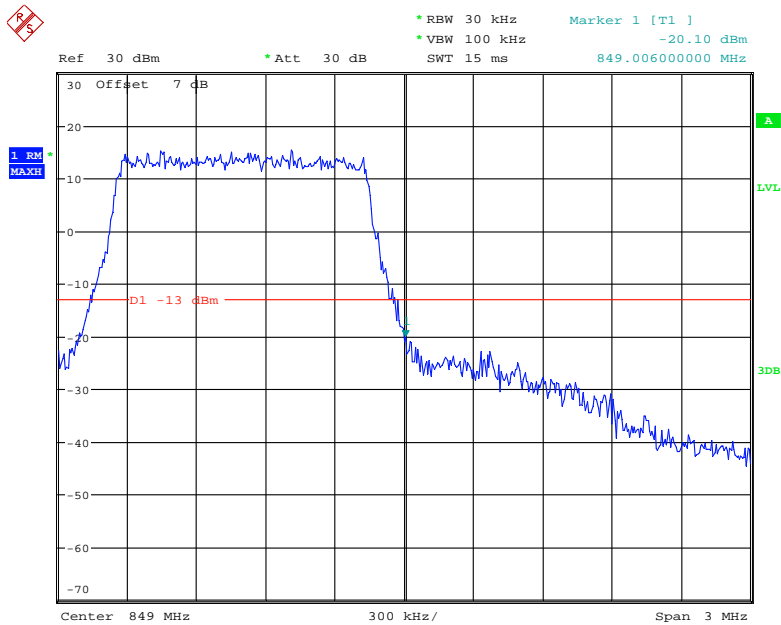

Date: 18.NOV.2020 14:59:49

16-QAM 1.4 MHz, FULL RB) - Left Band Edge

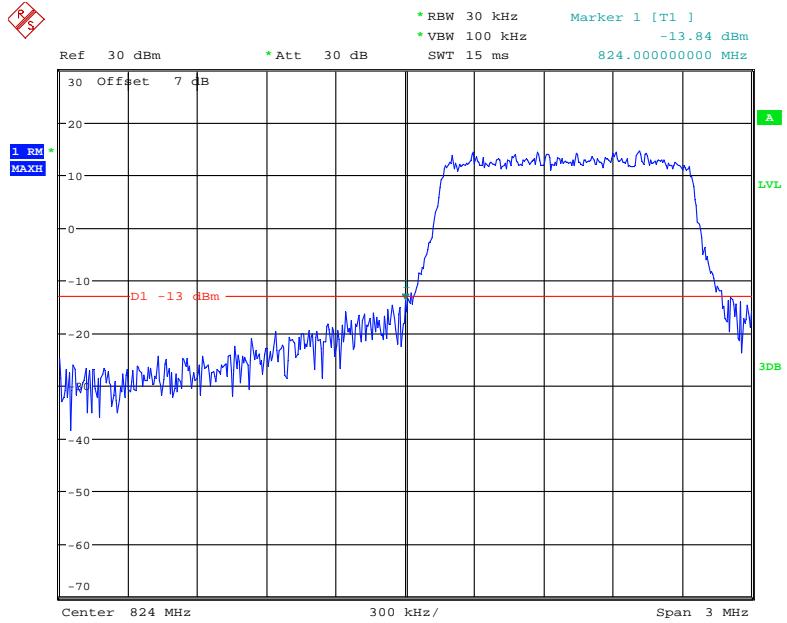

Date: 18.NOV.2020 14:59:32

16-QAM (1.4MHz, FULL RB) - Right Band Edge

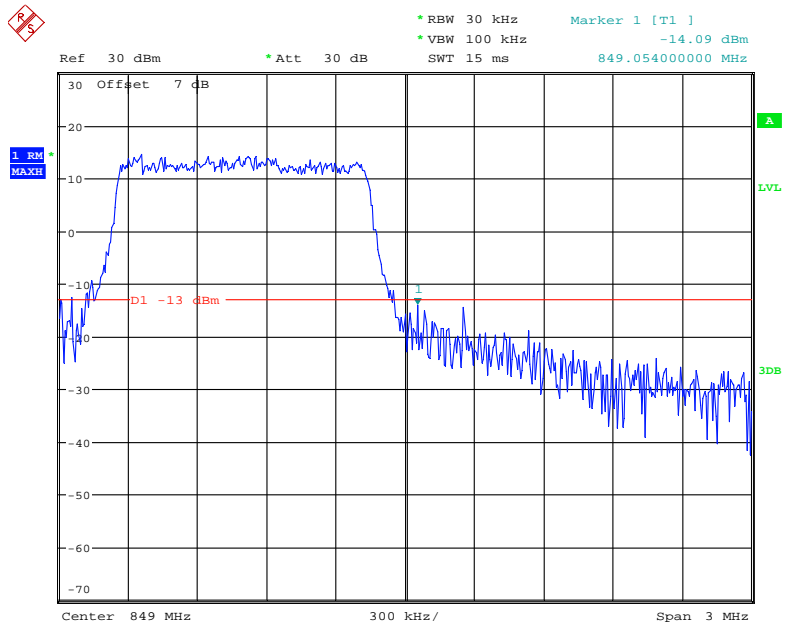

Date: 18.NOV.2020 15:00:12

QPSK (3.0 MHz, FULL RB) - Left Band Edge

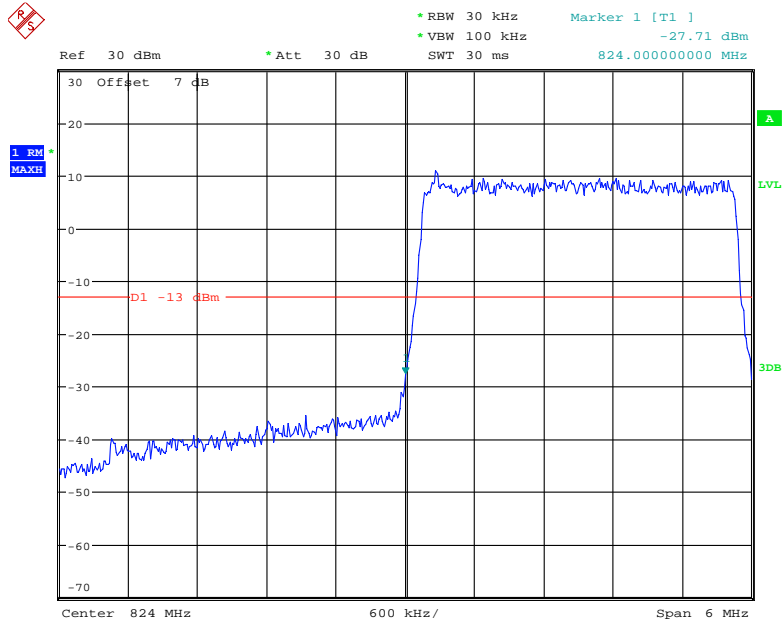

Date: 18.NOV.2020 15:00:31

QPSK (3.0 MHz, FULL RB) - Right Band Edge

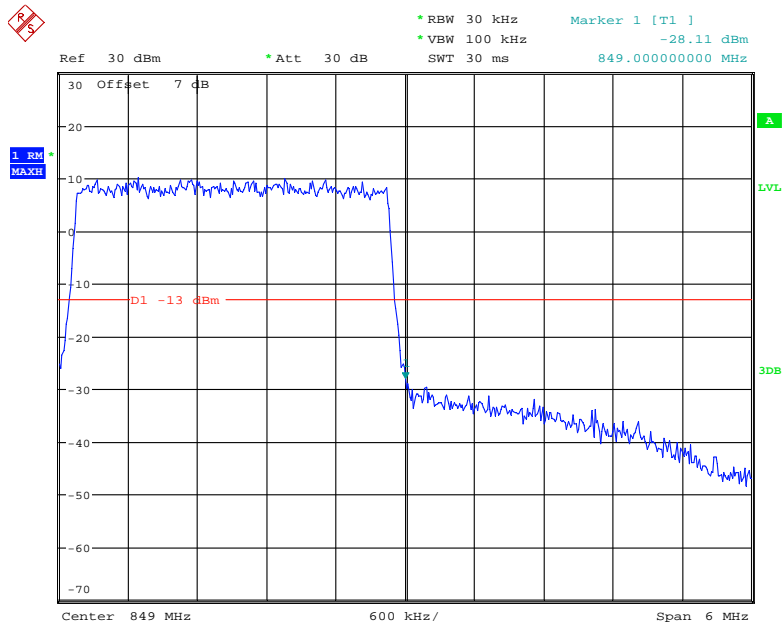

Date: 18.NOV.2020 15:01:21

16-QAM (3.0 MHz, FULL RB) - Left Band Edge

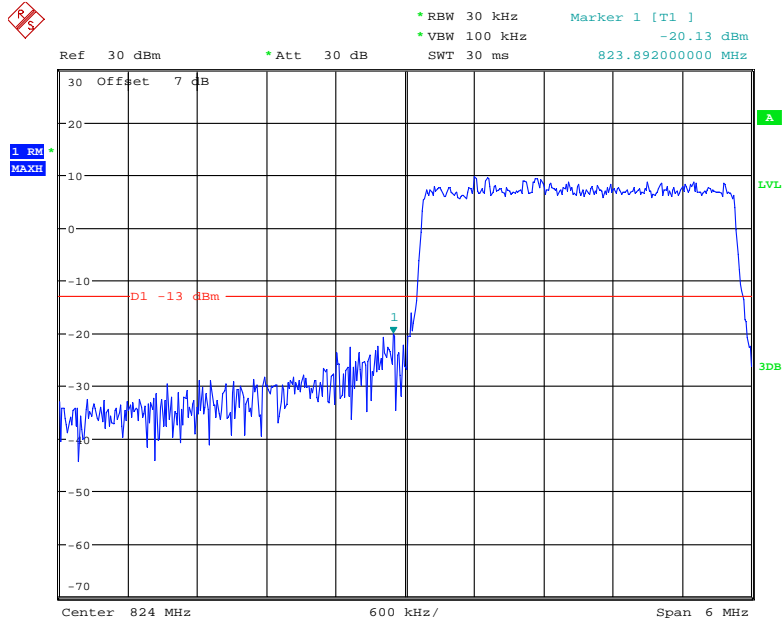

Date: 18.NOV.2020 15:01:03

16-QAM (3.0 MHz, FULL RB) - Right Band Edge

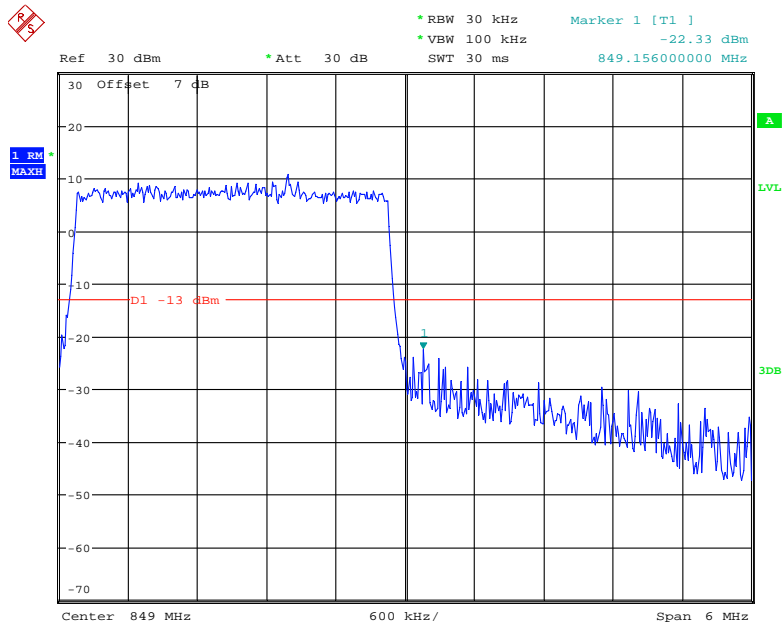

Date: 18.NOV.2020 15:01:40

QPSK (5.0 MHz, FULL RB) - Left Band Edge

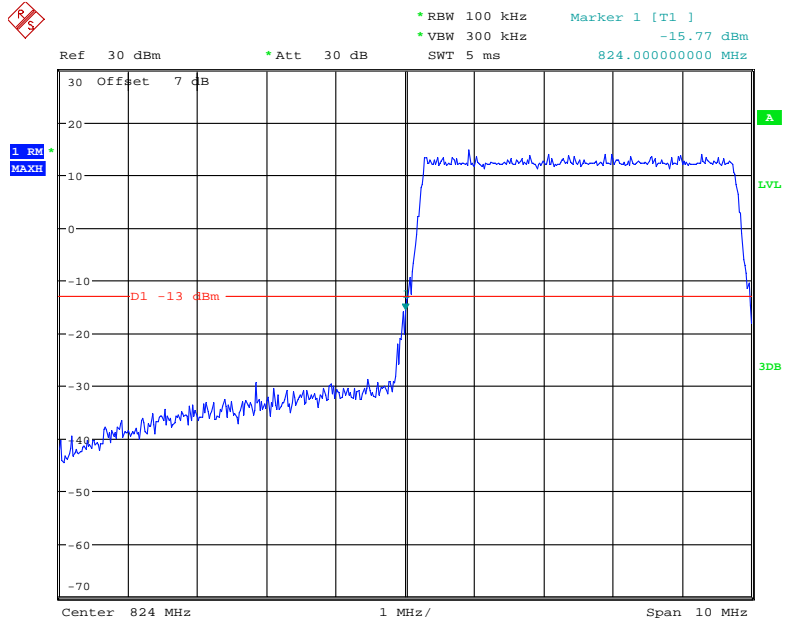

Date: 18.NOV.2020 15:02:01

QPSK (5.0 MHz, FULL RB) - Right Band Edge

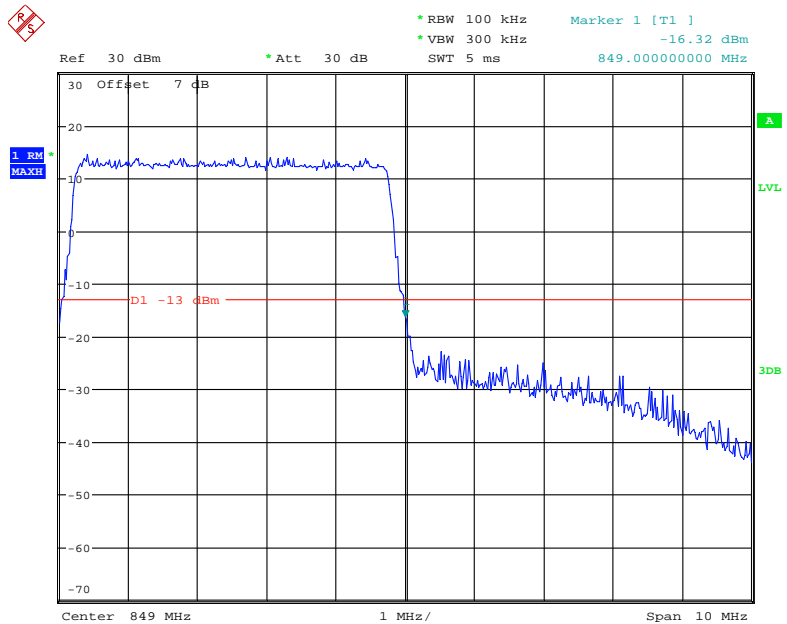

Date: 18.NOV.2020 15:02:44

16-QAM (5.0 MHz, FULL RB) - Left Band Edge

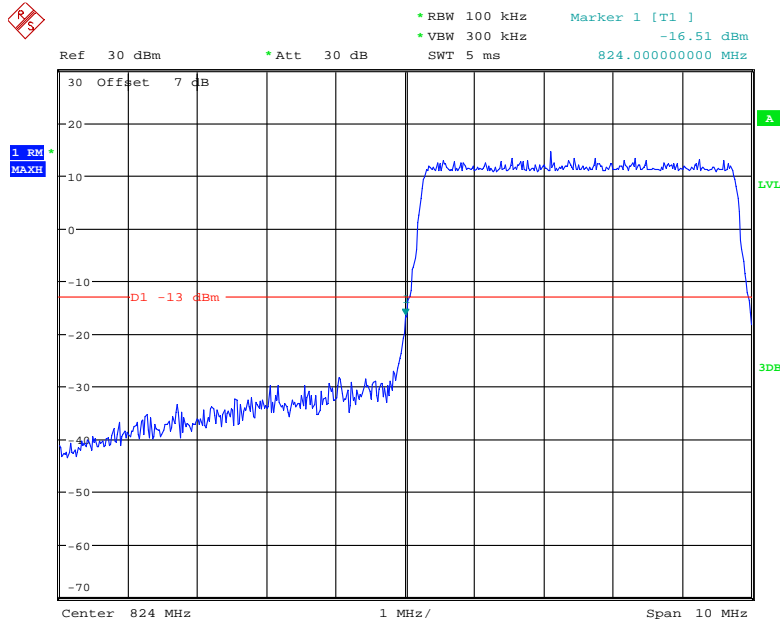

Date: 18.NOV.2020 15:02:22

16-QAM (5.0 MHz, FULL RB) - Right Band Edge

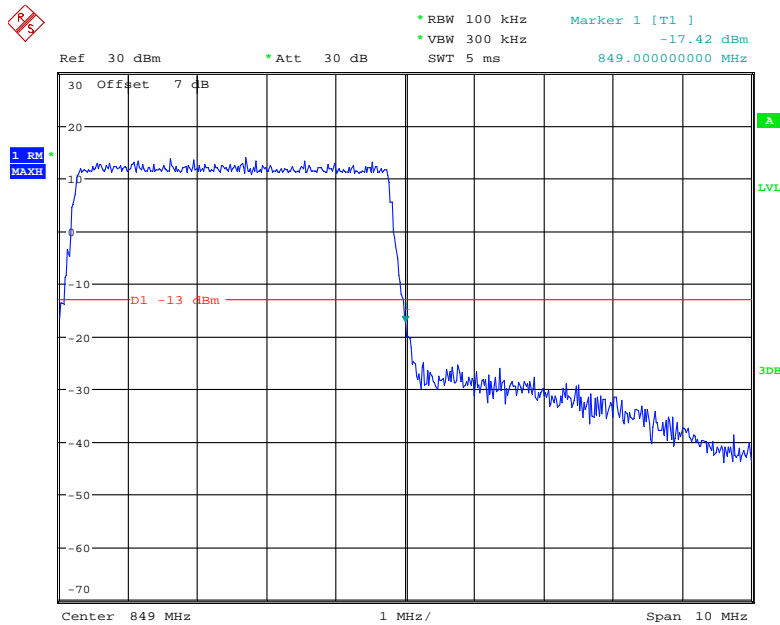

Date: 18.NOV.2020 15:03:07

QPSK (10.0 MHz, FULL RB) - Left Band Edge

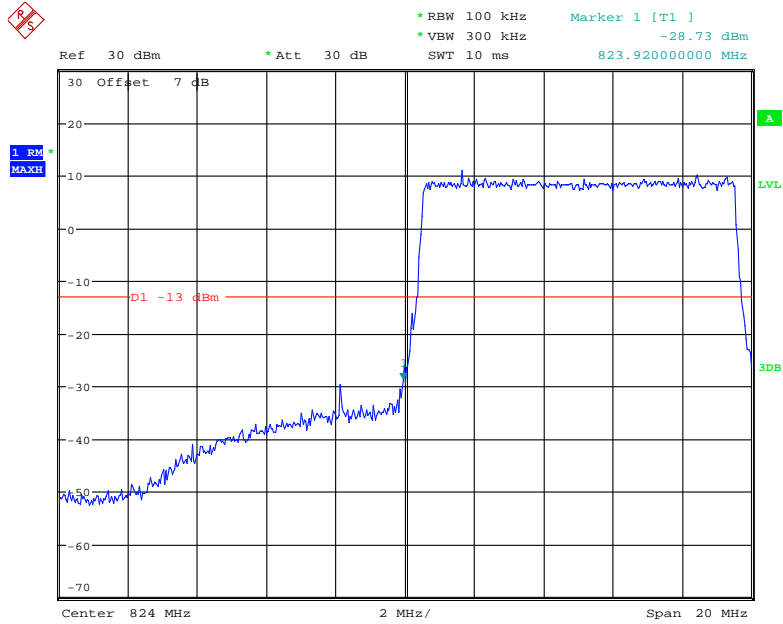

Date: 18.NOV.2020 15:03:28

QPSK (10.0 MHz, FULL RB) - Right Band Edge

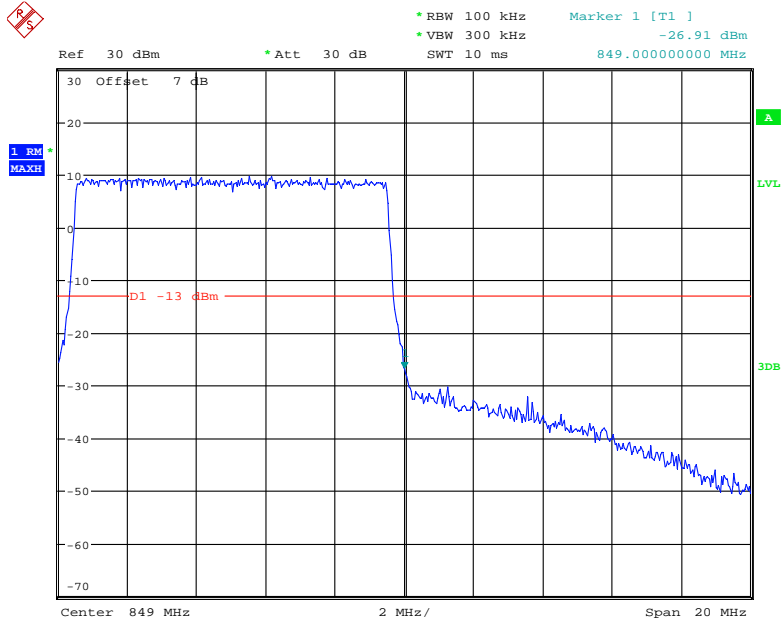

Date: 18.NOV.2020 15:04:07

16-QAM (10.0 MHz, FULL RB) - Left Band Edge

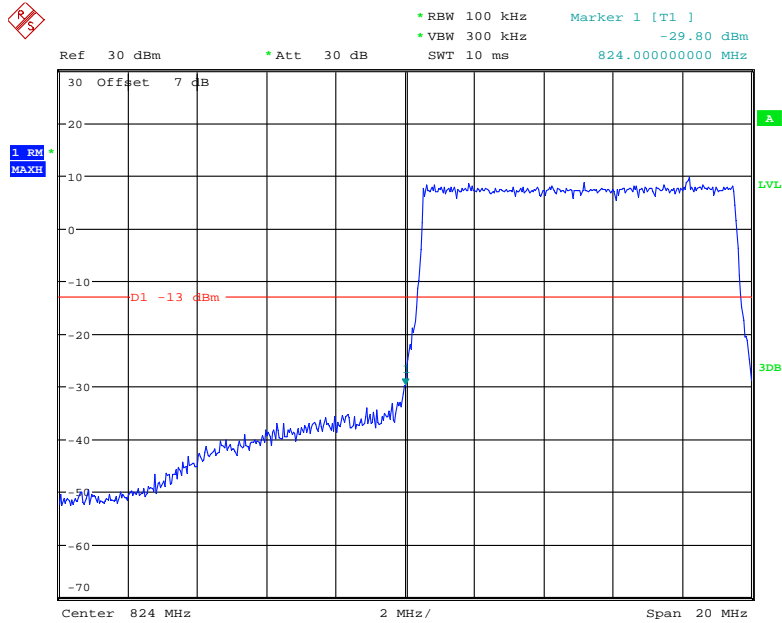

Date: 18.NOV.2020 15:03:45

16-QAM (10.0 MHz, FULL RB) - Right Band Edge

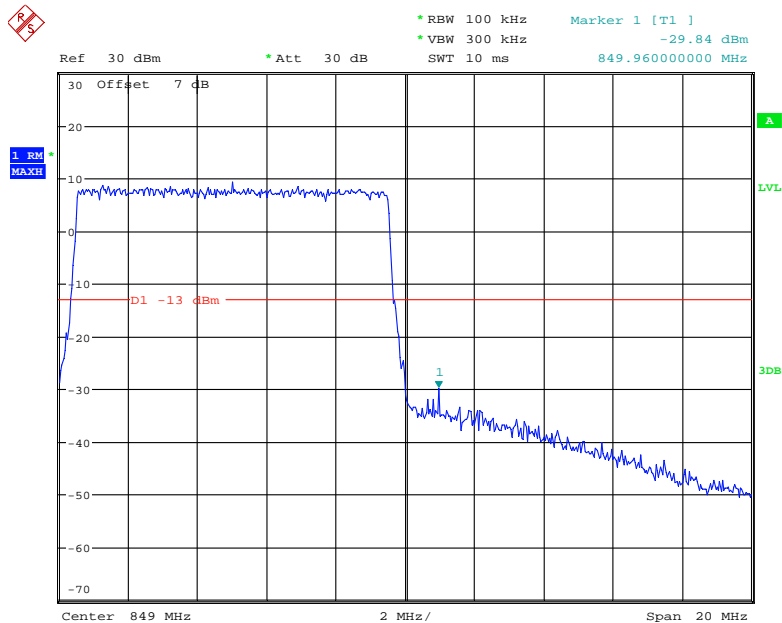

Date: 18.NOV.2020 15:04:25

LTE Band 7:

QPSK (5.0 MHz, FULL RB) - Left Band Edge

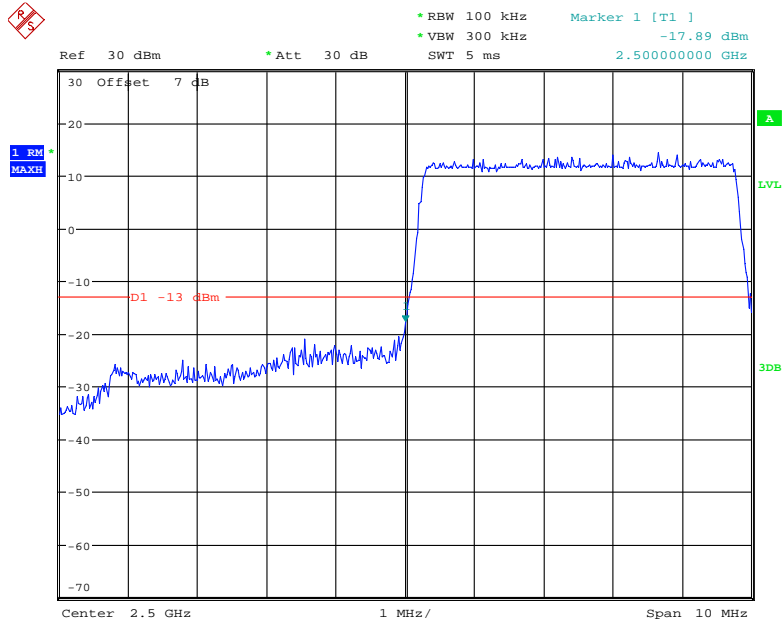

Date: 18.NOV.2020 15:04:48

QPSK (5.0 MHz, FULL RB) - Right Band Edge

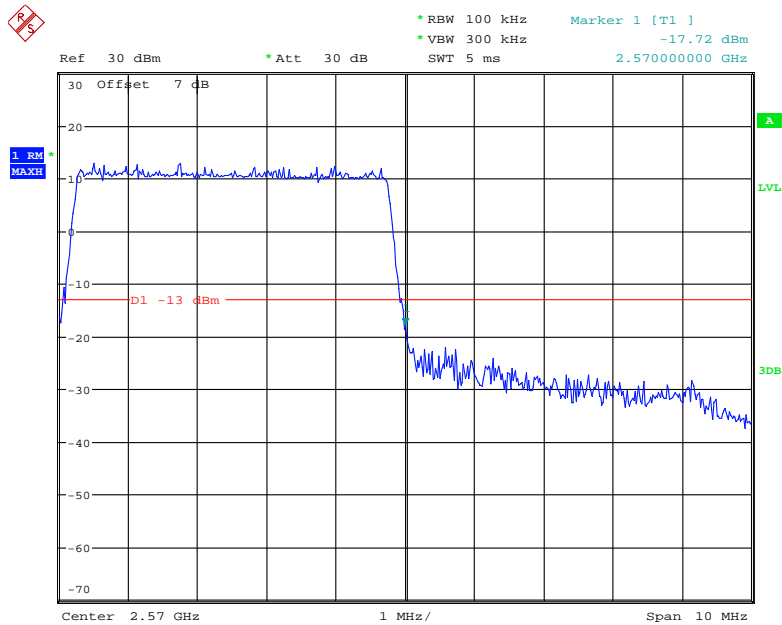

Date: 18.NOV.2020 15:05:34

16-QAM (5.0 MHz, FULL RB) - Left Band Edge

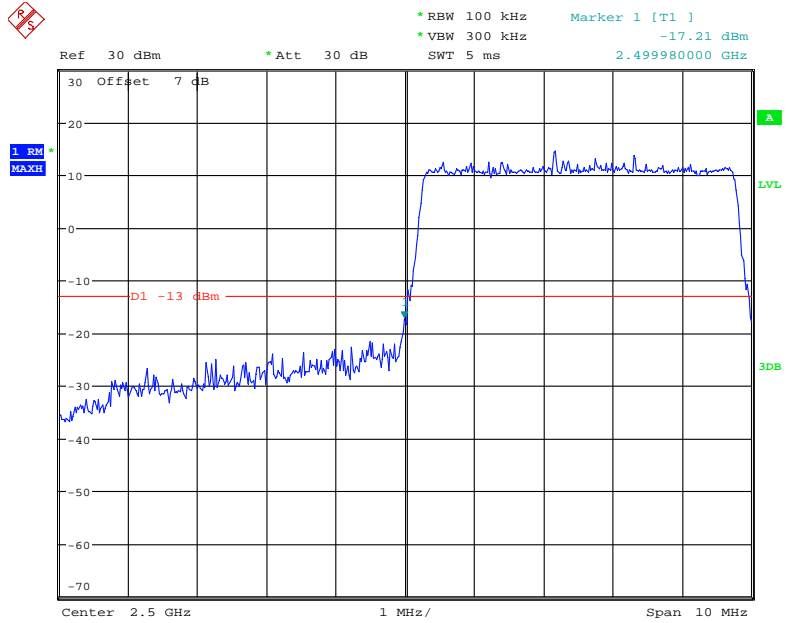

Date: 18.NOV.2020 15:05:09

16-QAM (5.0 MHz, FULL RB) - Right Band Edge

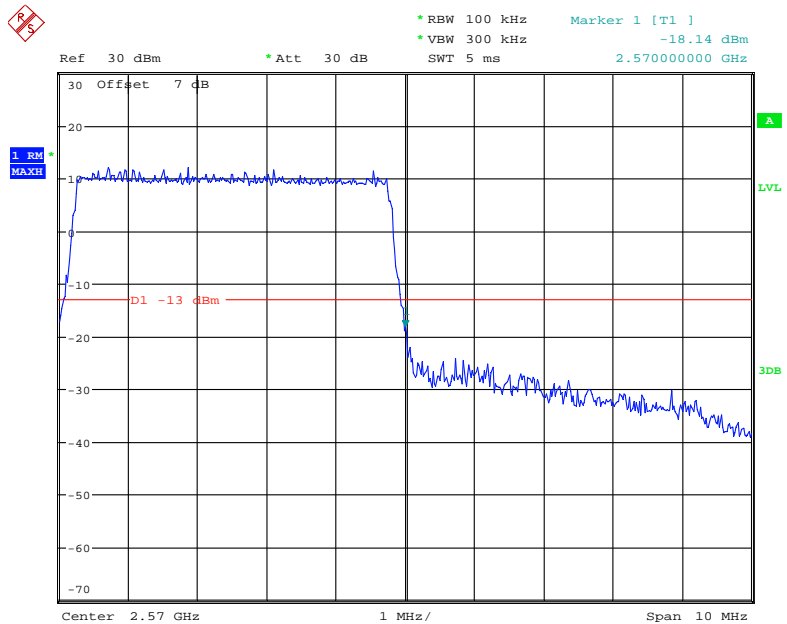

Date: 18.NOV.2020 15:05:54

QPSK (10.0 MHz, FULL RB) - Left Band Edge

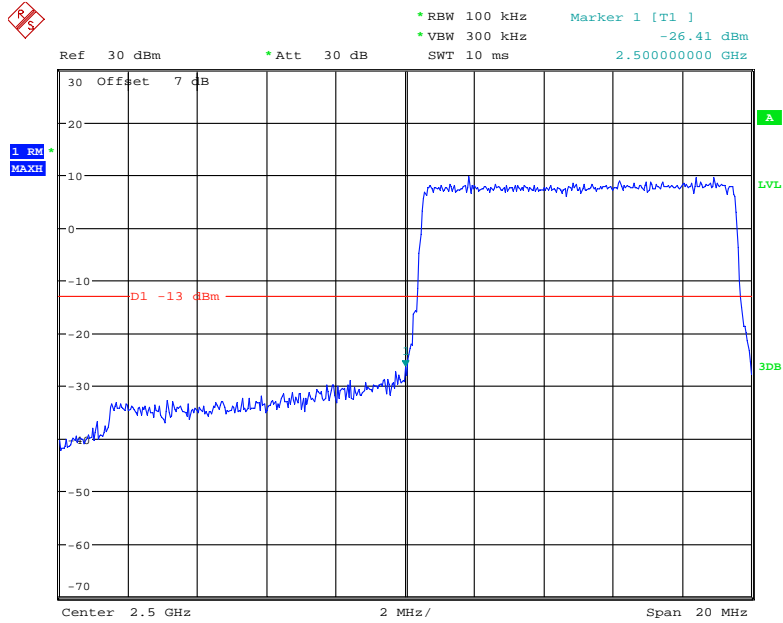

Date: 18.NOV.2020 15:06:15

QPSK (10.0 MHz, FULL RB) - Right Band Edge

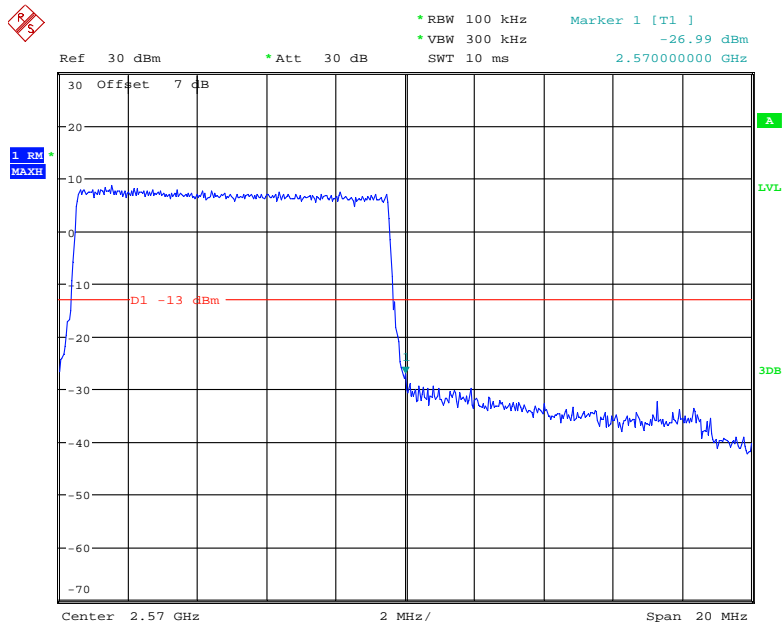

Date: 18.NOV.2020 15:06:55

16-QAM (10.0 MHz, FULL RB) - Left Band Edge

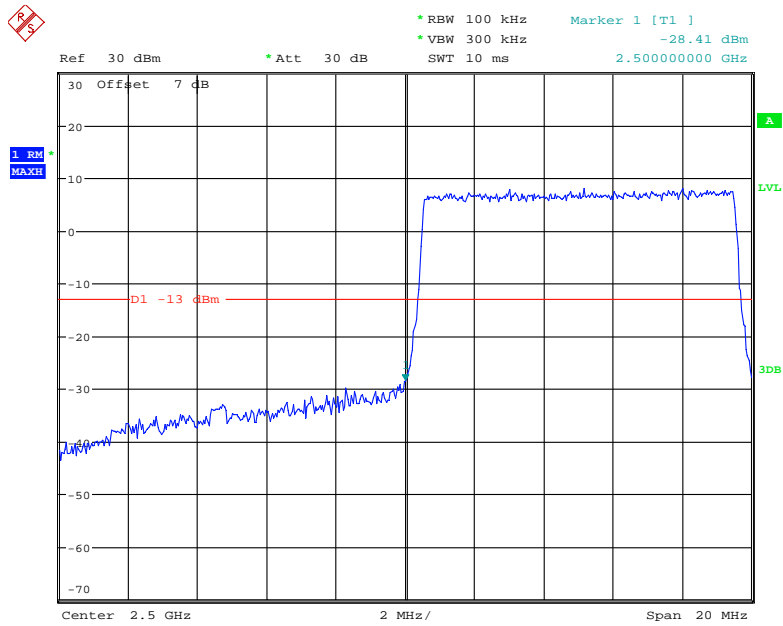

Date: 18.NOV.2020 15:06:33

16-QAM (10.0 MHz, FULL RB) - Right Band Edge

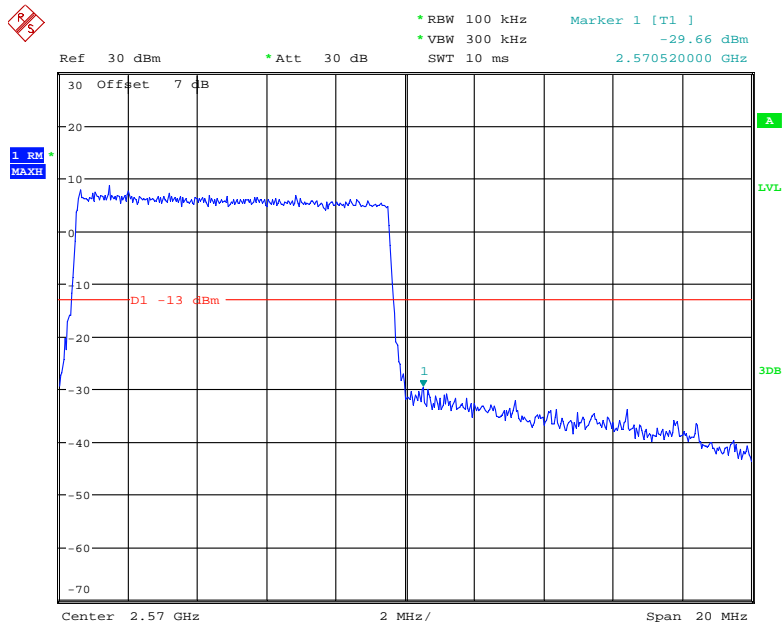

Date: 18.NOV.2020 15:07:13

QPSK (15.0 MHz, FULL RB) - Left Band Edge

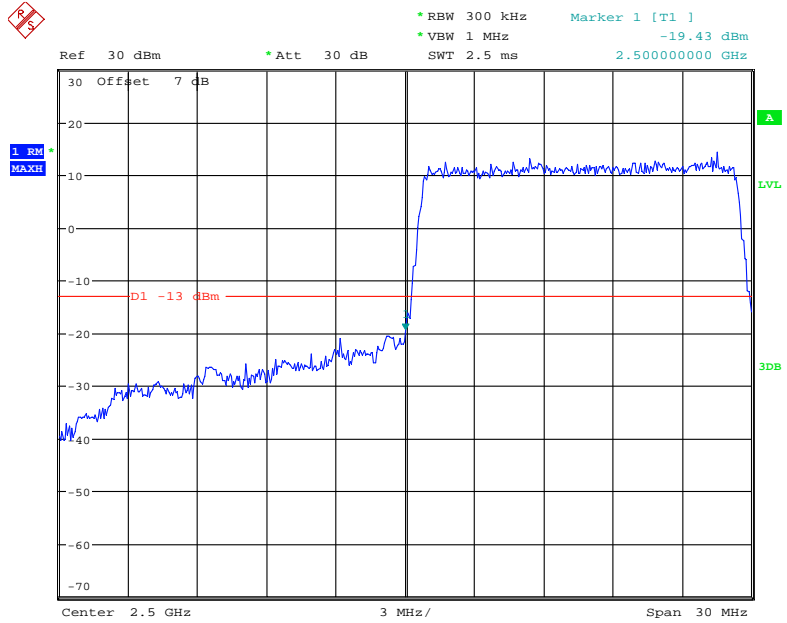

Date: 18.NOV.2020 15:07:37

QPSK (15.0 MHz, FULL RB) - Right Band Edge

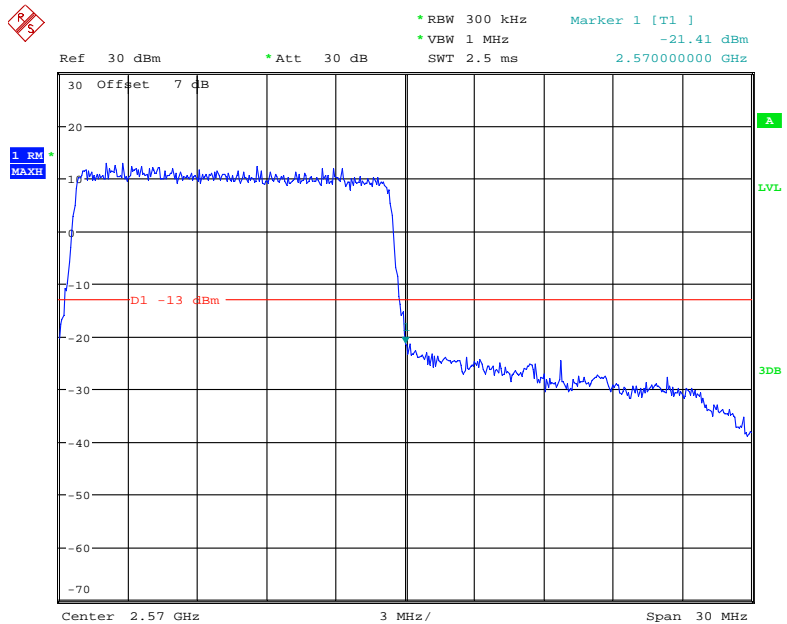

Date: 18.NOV.2020 15:08:23

16-QAM (15.0 MHz, FULL RB) - Left Band Edge

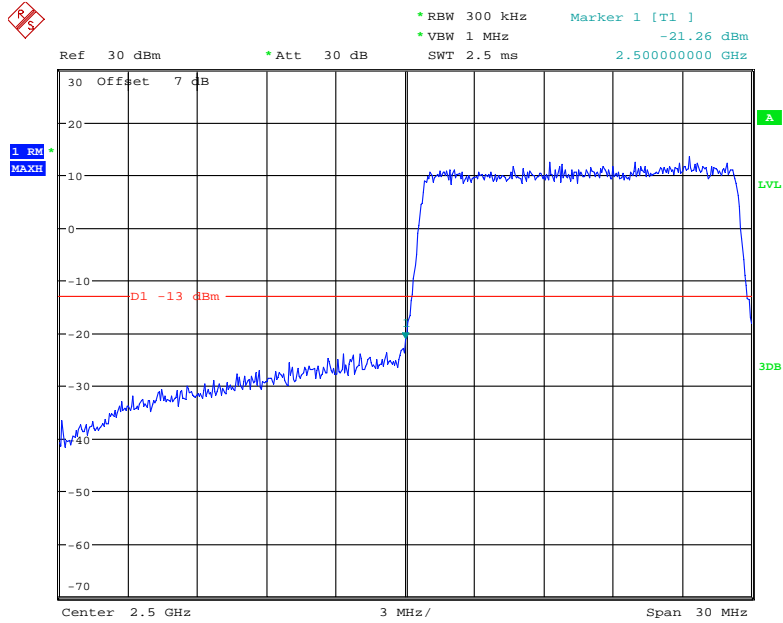

Date: 18.NOV.2020 15:08:02

16-QAM (15.0 MHz, FULL RB) - Right Band Edge

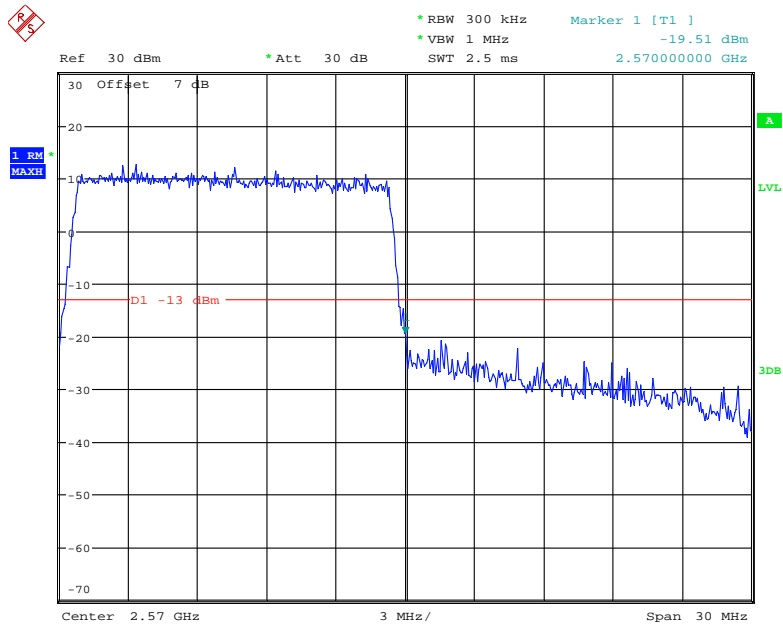

Date: 18.NOV.2020 15:08:47

QPSK (20.0 MHz, FULL RB) - Left Band Edge

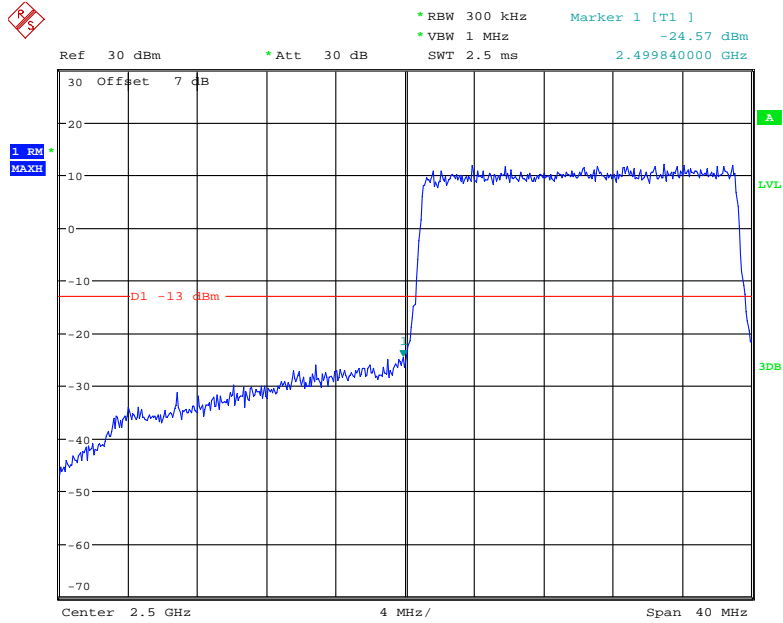

Date: 18.NOV.2020 15:09:15

QPSK (20.0 MHz, FULL RB) - Right Band Edge

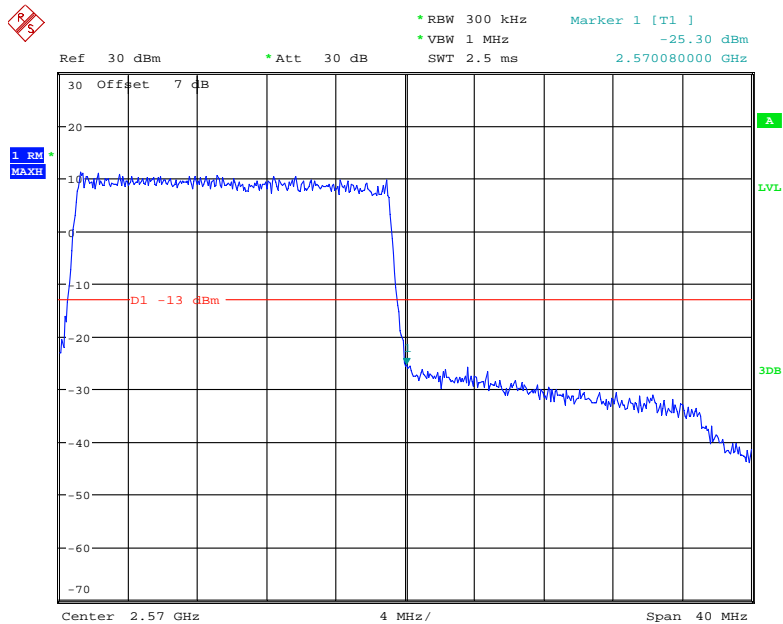

Date: 18.NOV.2020 15:10:01

16-QAM (20.0 MHz, FULL RB) - Left Band Edge

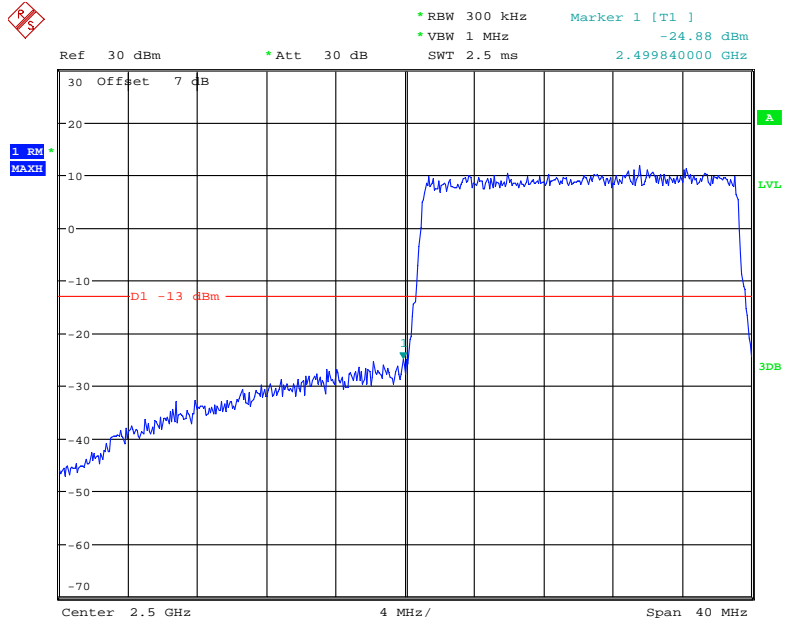

Date: 18.NOV.2020 15:09:39

16-QAM (20.0 MHz, FULL RB) - Right Band Edge

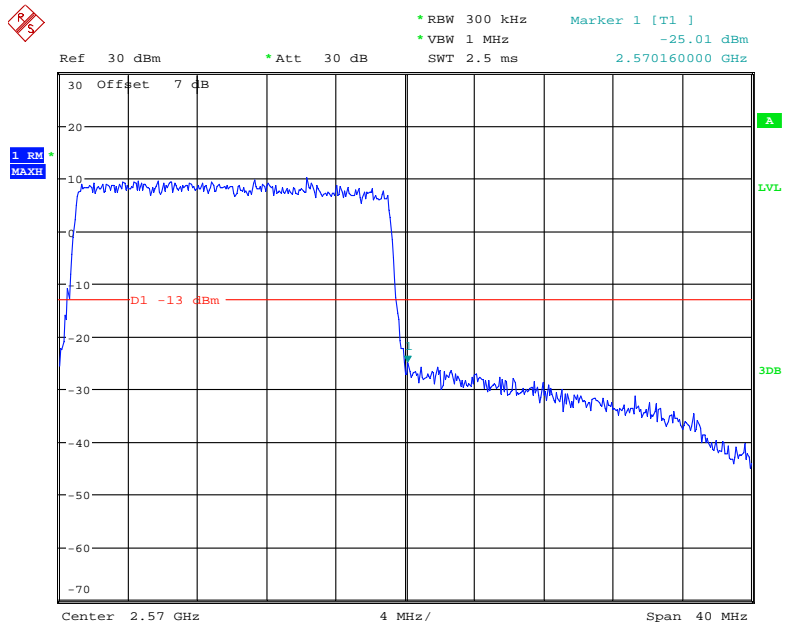

Date: 18.NOV.2020 15:10:25

LTE Band 38:

QPSK (5.0 MHz, FULL RB) - Left Band Edge

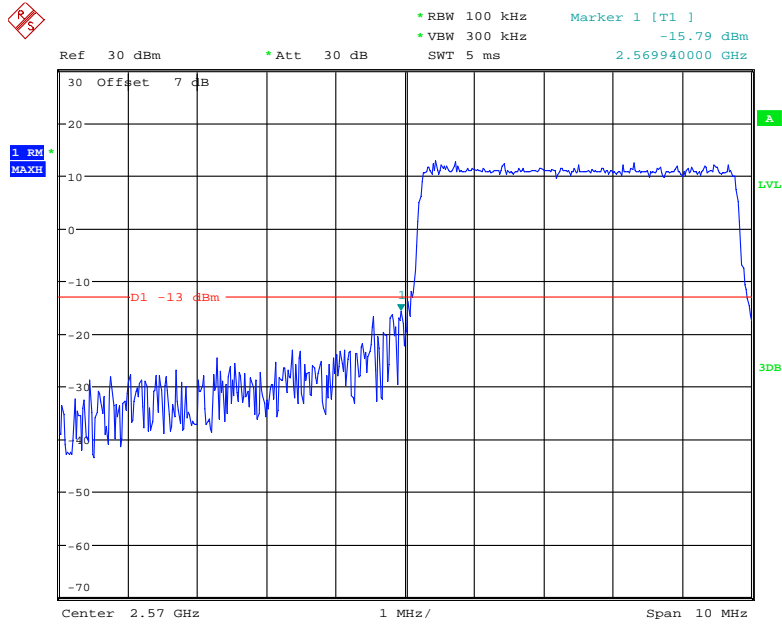

Date: 18.NOV.2020 16:11:57

QPSK (5.0 MHz, FULL RB) - Right Band Edge

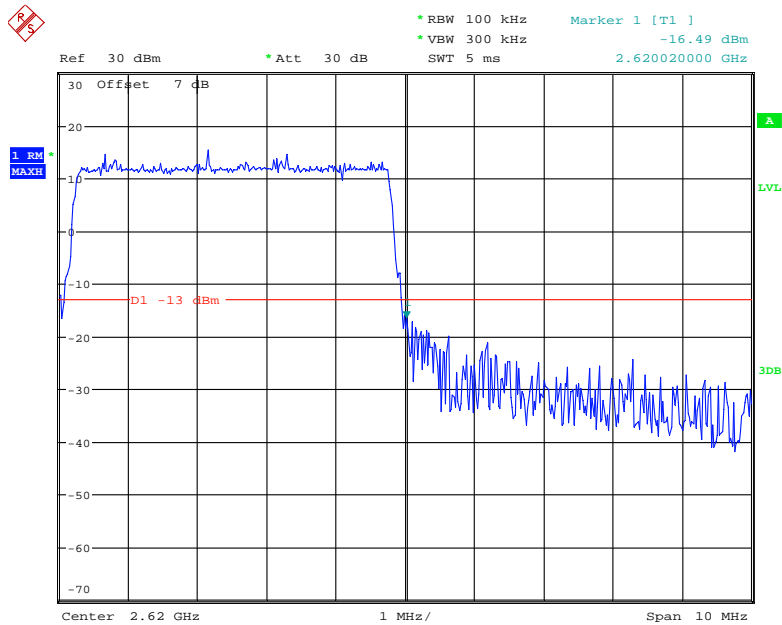

Date: 18.NOV.2020 16:12:50

16-QAM (5.0 MHz, FULL RB) - Left Band Edge

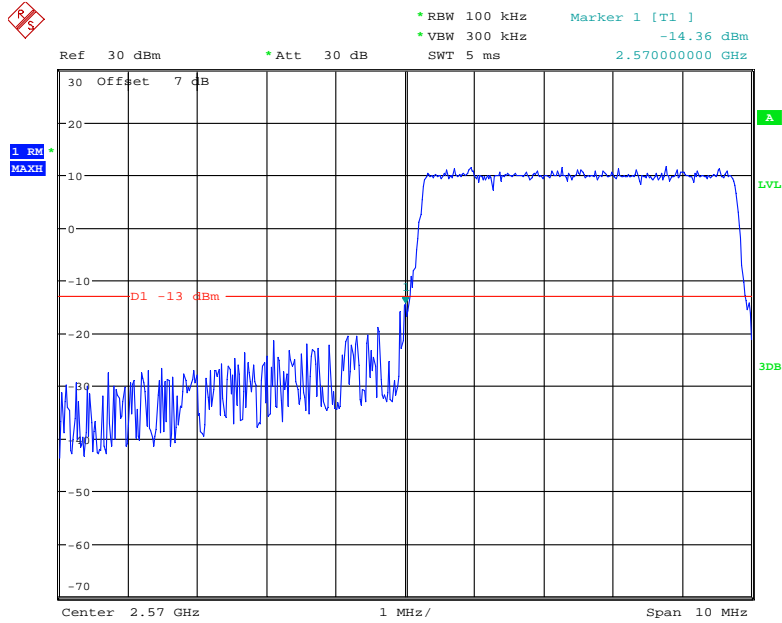

Date: 18.NOV.2020 16:12:23

16-QAM (5.0 MHz, FULL RB) - Right Band Edge

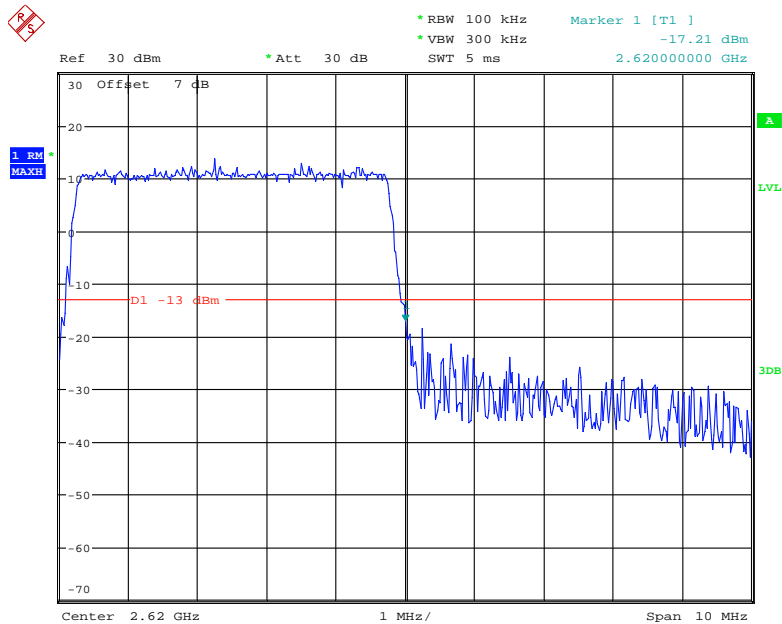

Date: 18.NOV.2020 16:13:09

QPSK (10.0 MHz, FULL RB) - Left Band Edge

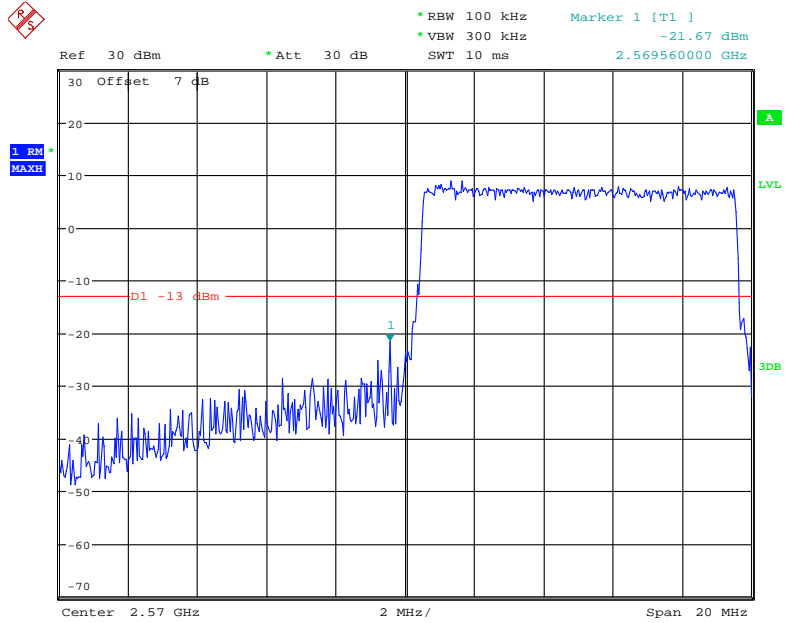

Date: 18.NOV.2020 16:13:32

QPSK (10.0 MHz, FULL RB) - Right Band Edge

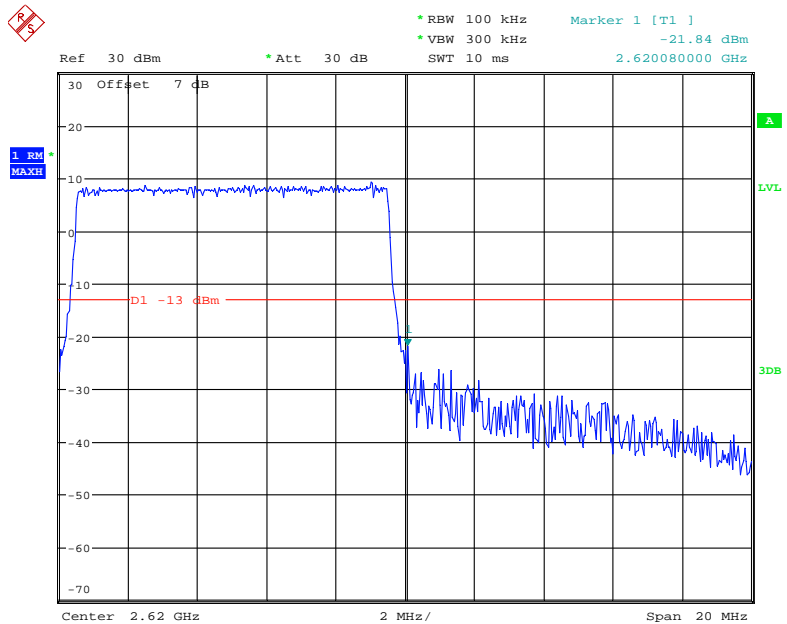

Date: 18.NOV.2020 16:14:27

16-QAM (10.0 MHz, FULL RB) - Left Band Edge

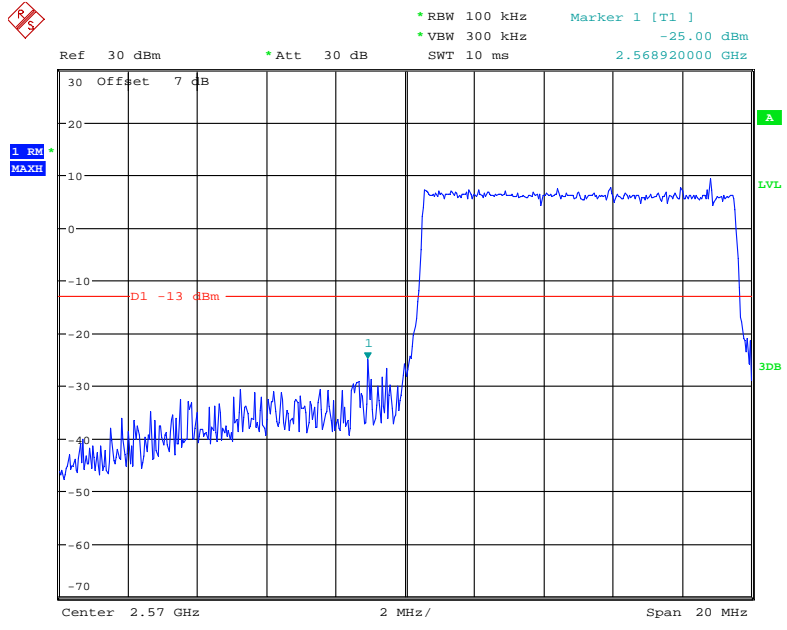

Date: 18.NOV.2020 16:13:59

16-QAM (10.0 MHz, FULL RB) - Right Band Edge

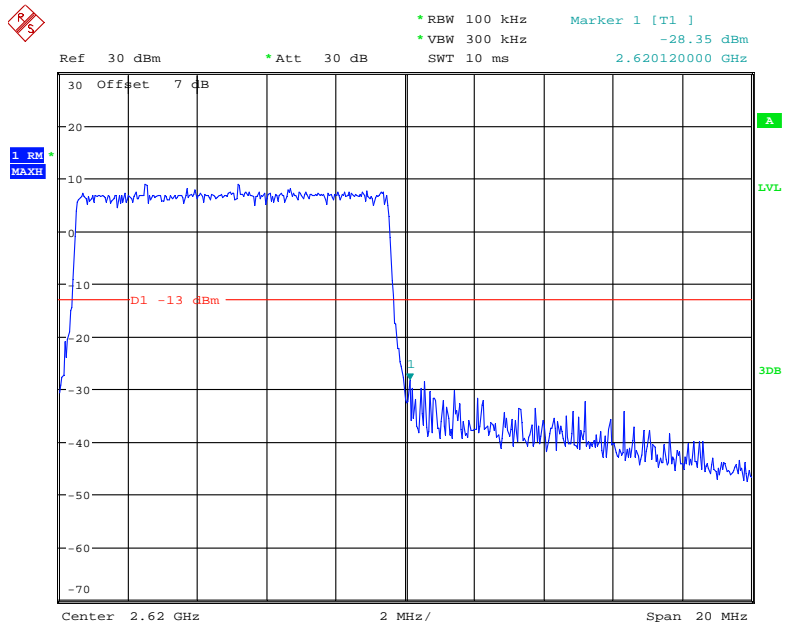

Date: 18.NOV.2020 16:14:48

QPSK (15.0 MHz, FULL RB) - Left Band Edge

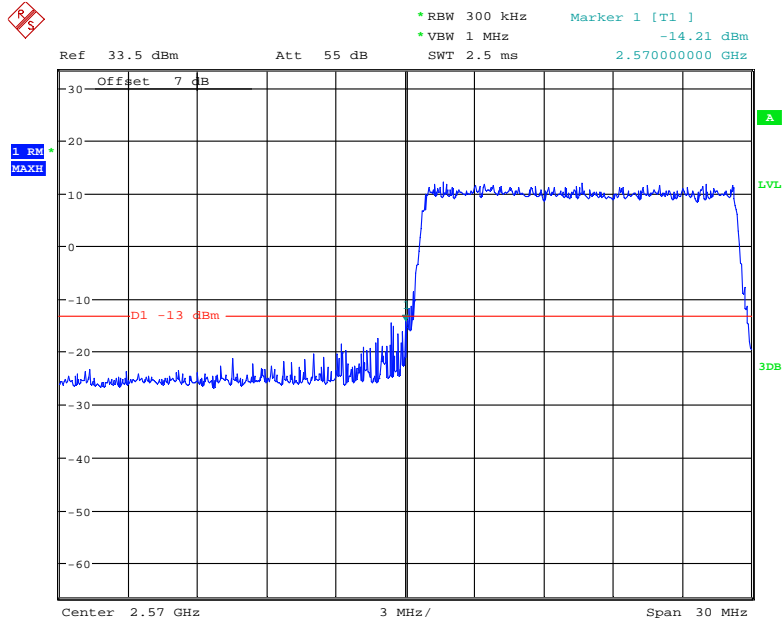

Date: 26.NOV.2020 09:50:30

QPSK (15.0 MHz, FULL RB) - Right Band Edge

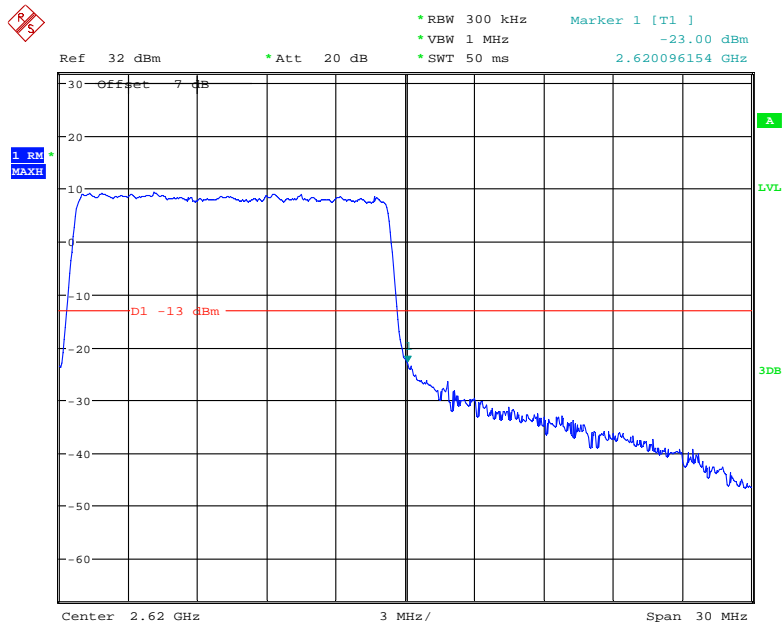

Date: 23.NOV.2020 14:28:00

16-QAM (15.0 MHz, FULL RB) - Left Band Edge

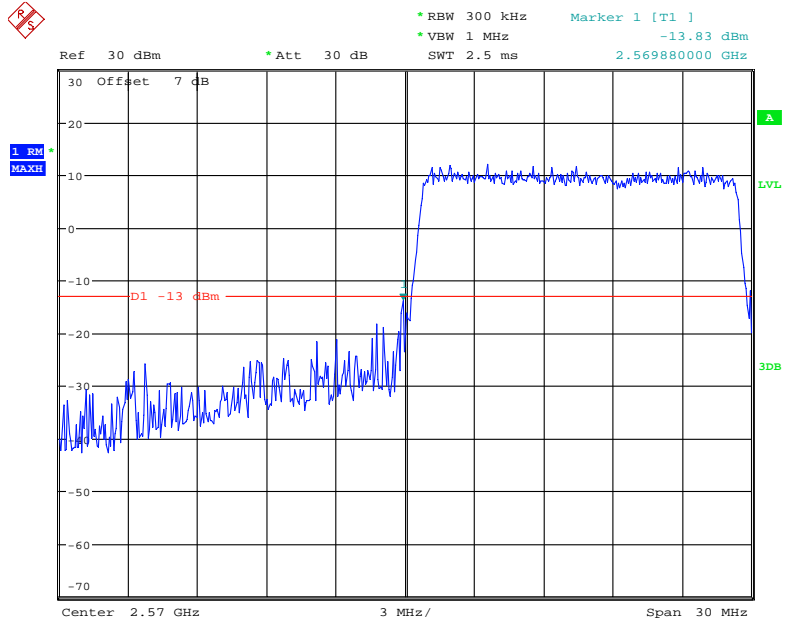

Date: 18.NOV.2020 16:15:52

16-QAM (15.0 MHz, FULL RB) - Right Band Edge

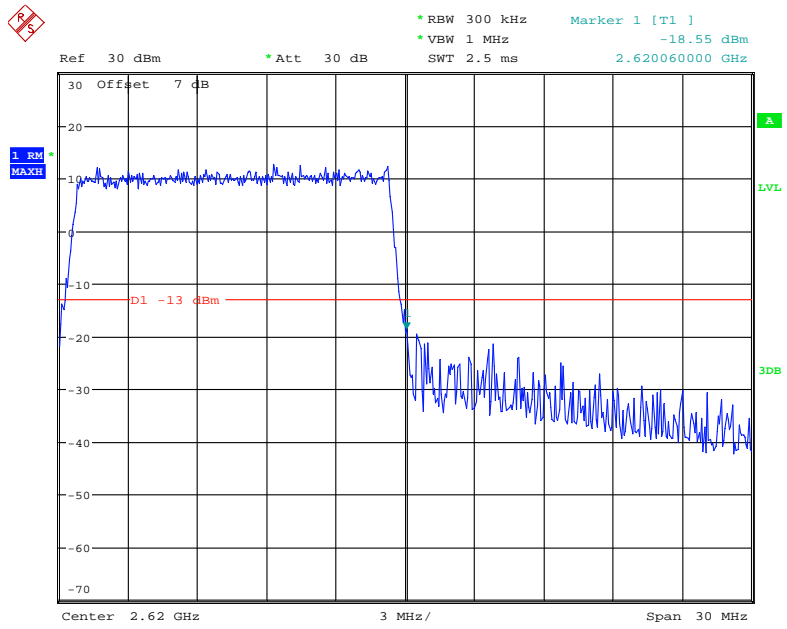

Date: 18.NOV.2020 16:16:45

QPSK (20.0 MHz, FULL RB) - Left Band Edge

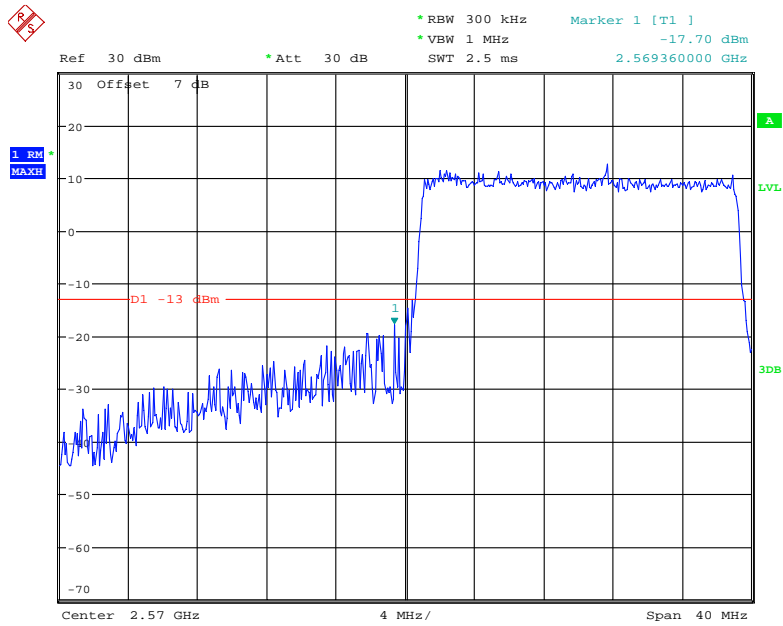

Date: 18.NOV.2020 16:17:17

QPSK (20.0 MHz, FULL RB) - Right Band Edge

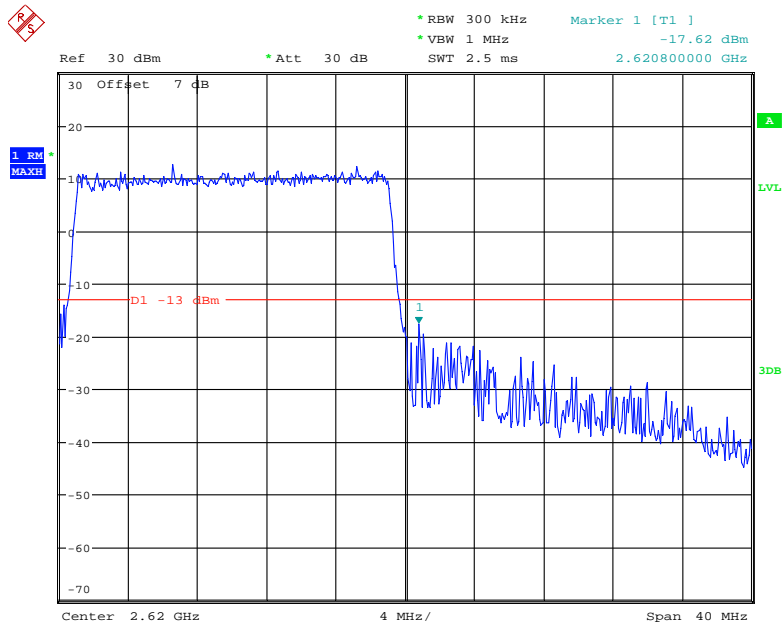

Date: 18.NOV.2020 16:18:16

16-QAM (20.0 MHz, FULL RB) - Left Band Edge

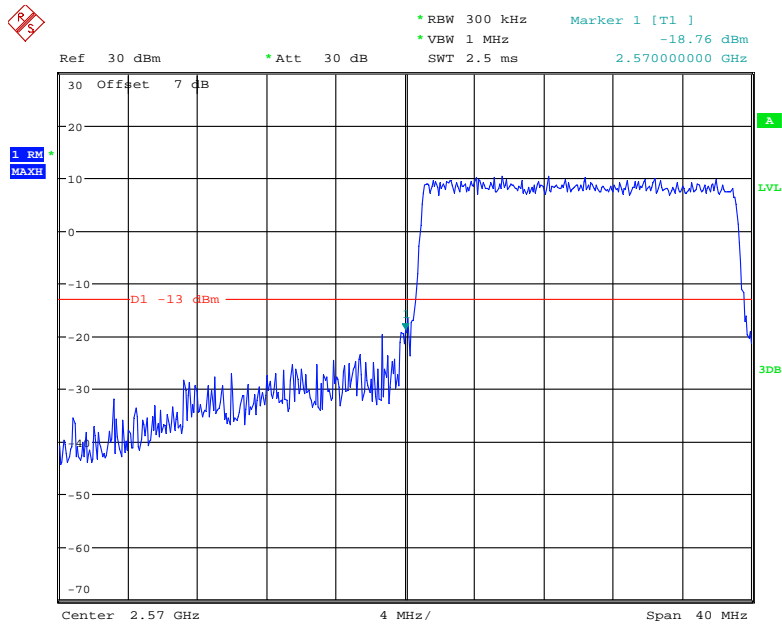

Date: 18.NOV.2020 16:17:46

16-QAM (20.0 MHz, FULL RB) - Right Band Edge

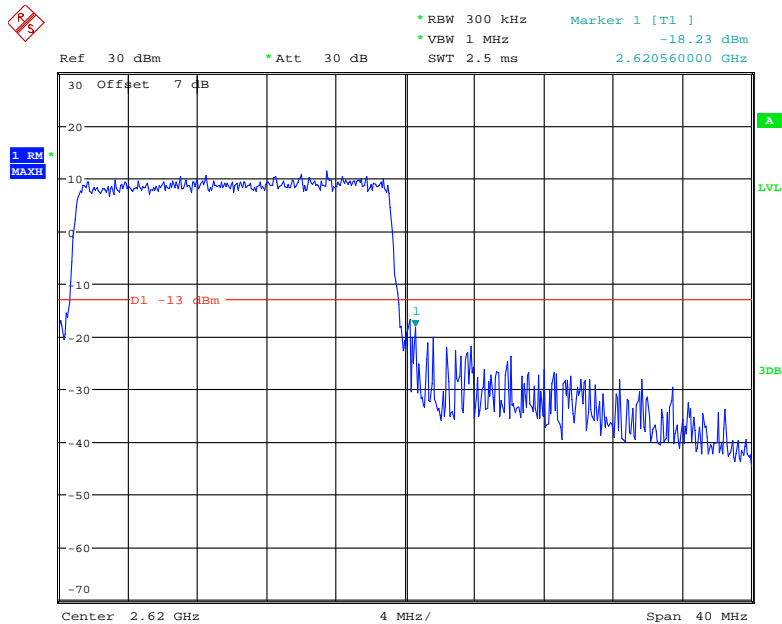

Date: 18.NOV.2020 16:18:42

LTE Band 41:

QPSK (5.0 MHz, FULL RB) - Left Band Edge

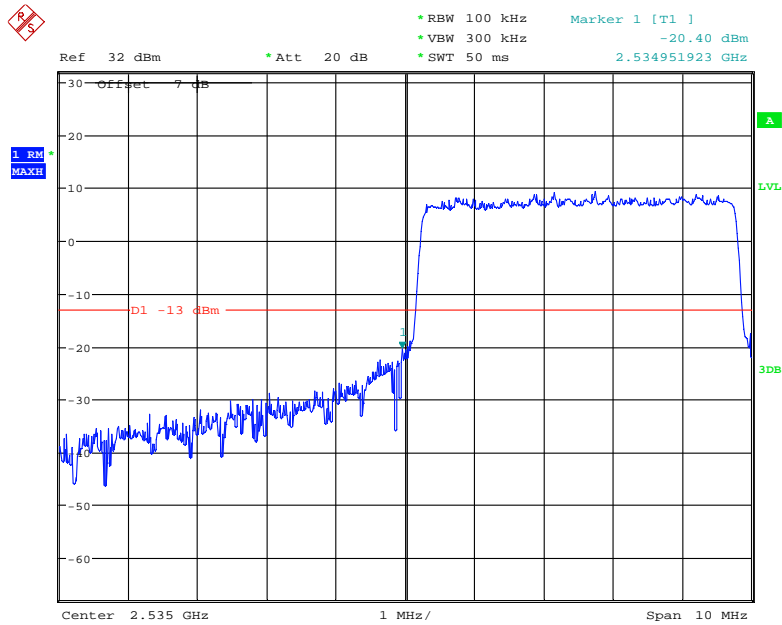

Date: 23.NOV.2020 14:42:32

QPSK (5.0 MHz, FULL RB) - Right Band Edge

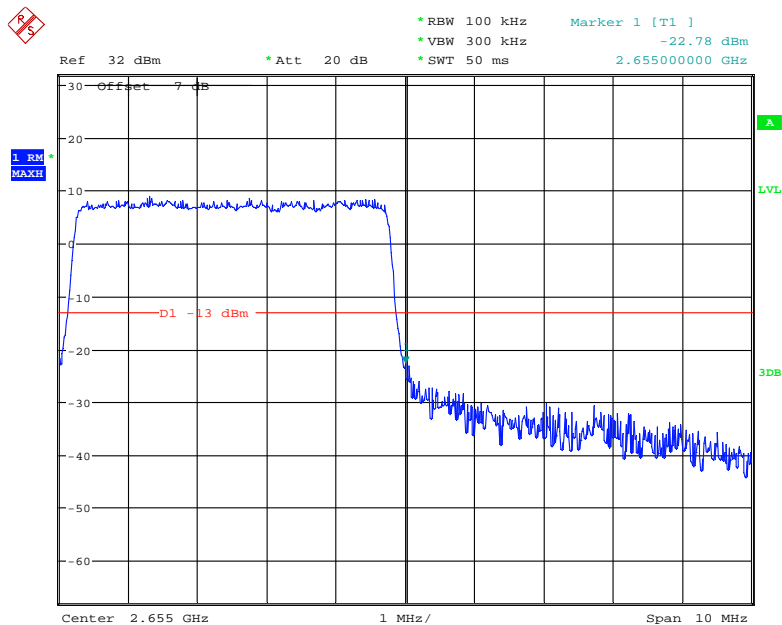

Date: 23.NOV.2020 15:03:17

16-QAM (5.0 MHz, FULL RB) - Left Band Edge

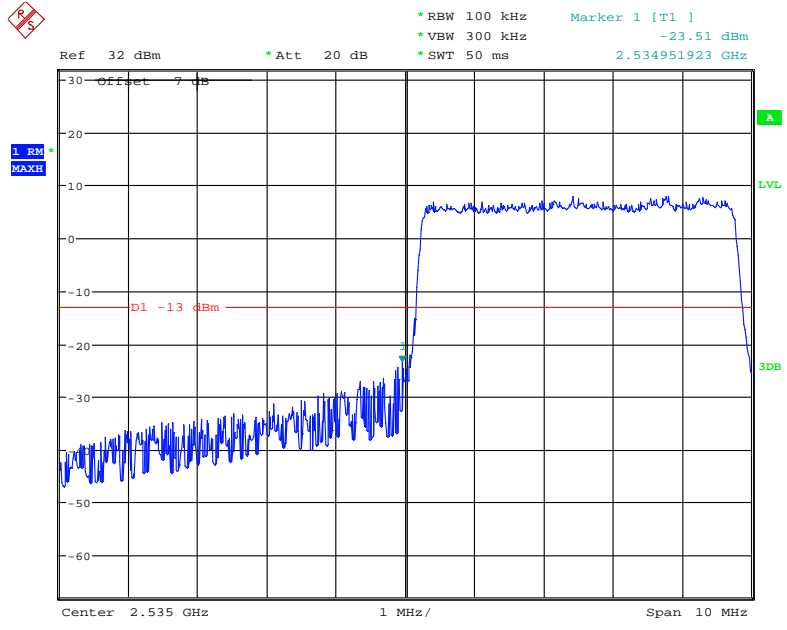

Date: 23.NOV.2020 14:43:12

16-QAM (5.0 MHz, FULL RB) - Right Band Edge

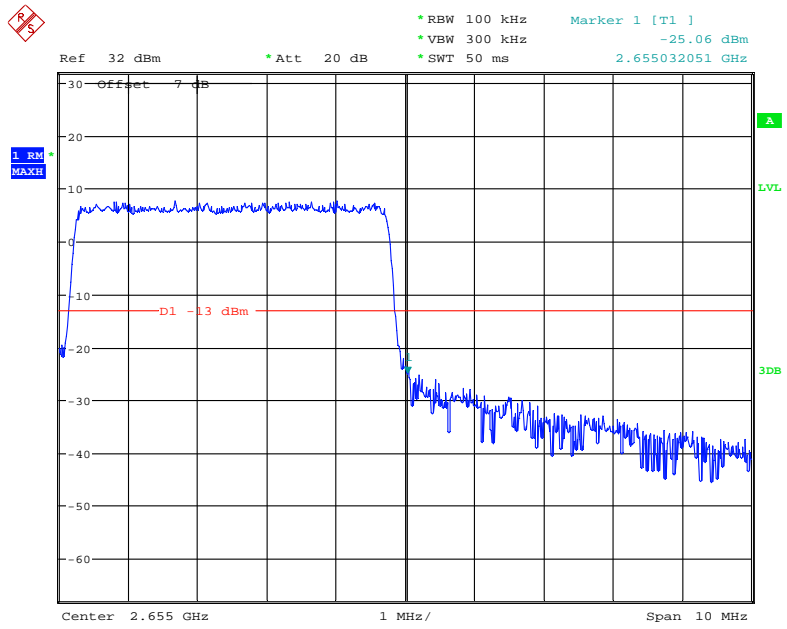

Date: 23.NOV.2020 15:02:40

QPSK (10.0 MHz, FULL RB) - Left Band Edge

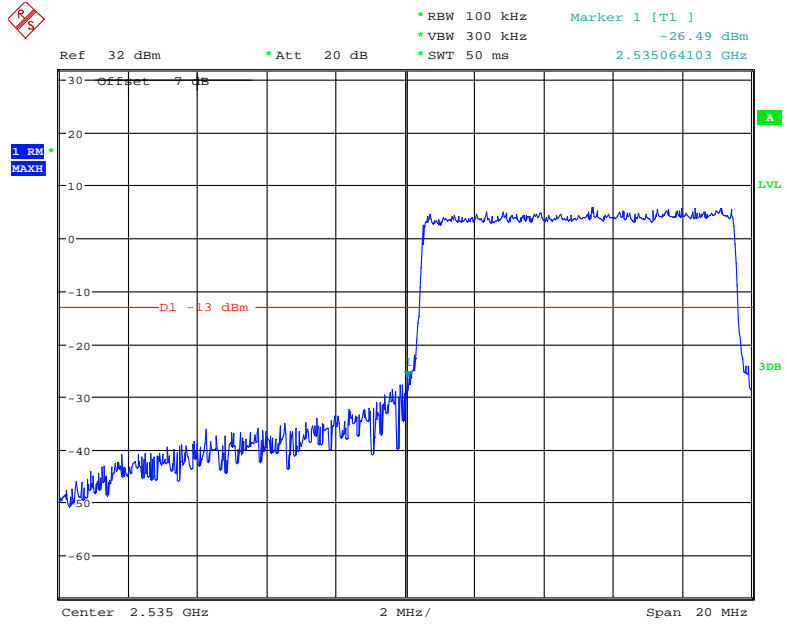

Date: 23.NOV.2020 15:04:34

QPSK (10.0 MHz, FULL RB) - Right Band Edge

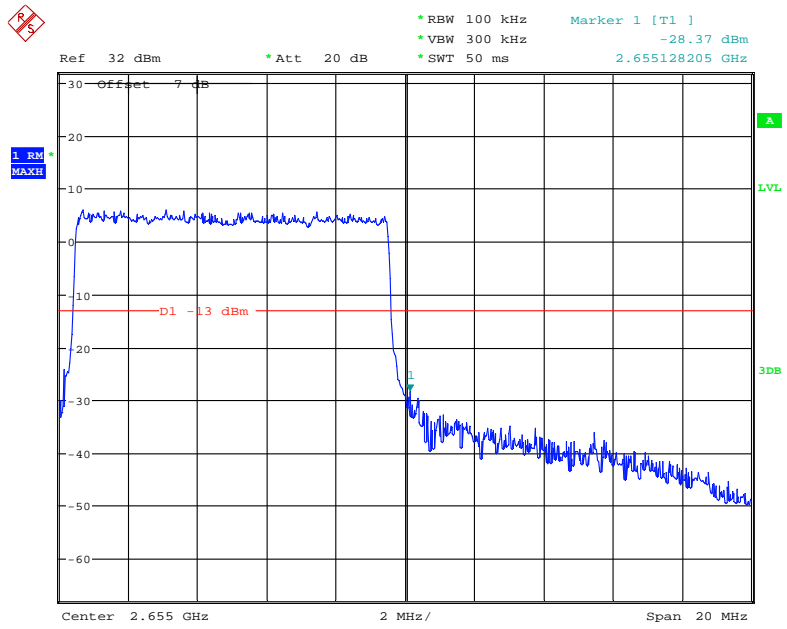

Date: 23.NOV.2020 15:11:40

16-QAM (10.0 MHz, FULL RB) - Left Band Edge

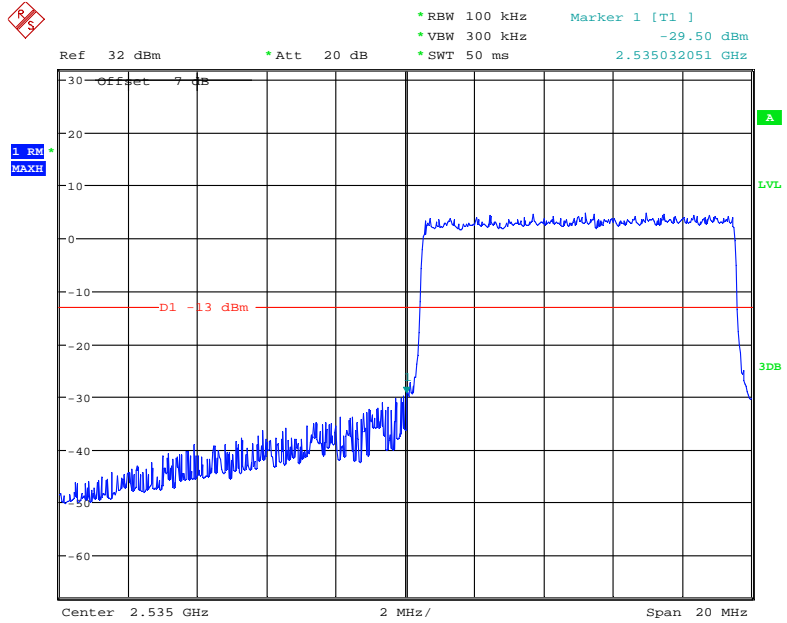

Date: 23.NOV.2020 15:05:09

16-QAM (10.0 MHz, FULL RB) - Right Band Edge

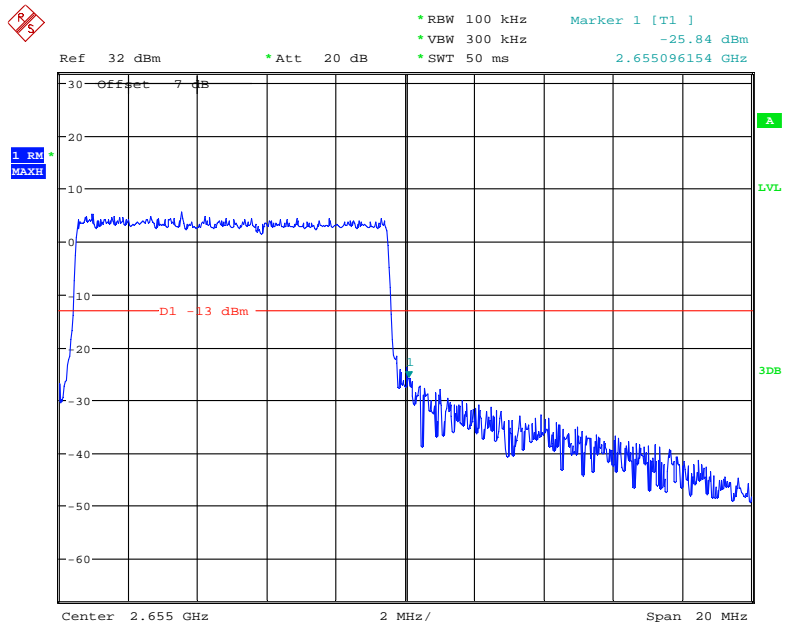

Date: 23.NOV.2020 15:10:52

QPSK (15.0 MHz, FULL RB) - Left Band Edge

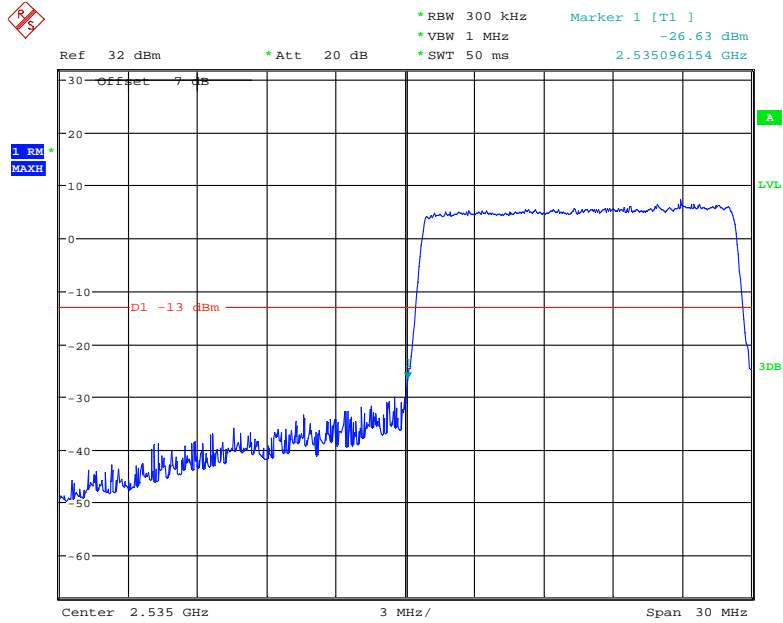

Date: 23.NOV.2020 15:29:18

QPSK (15.0 MHz, FULL RB) - Right Band Edge

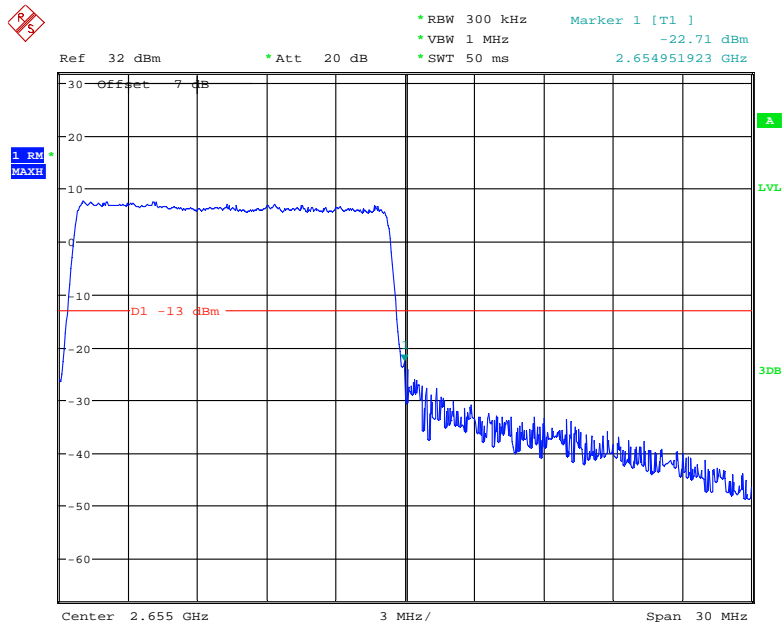

Date: 23.NOV.2020 15:26:38

16-QAM (15.0 MHz, FULL RB) - Left Band Edge

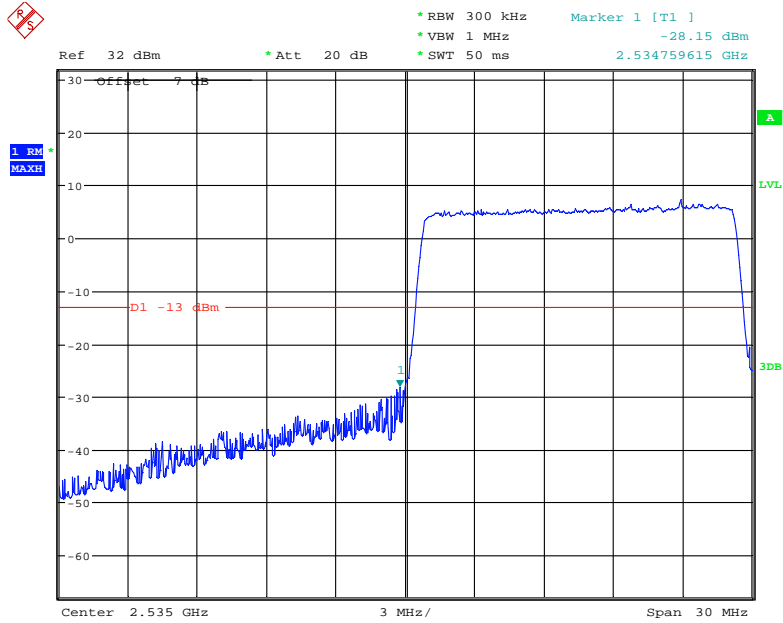

Date: 23.NOV.2020 15:39:12

16-QAM (15.0 MHz, FULL RB) - Right Band Edge

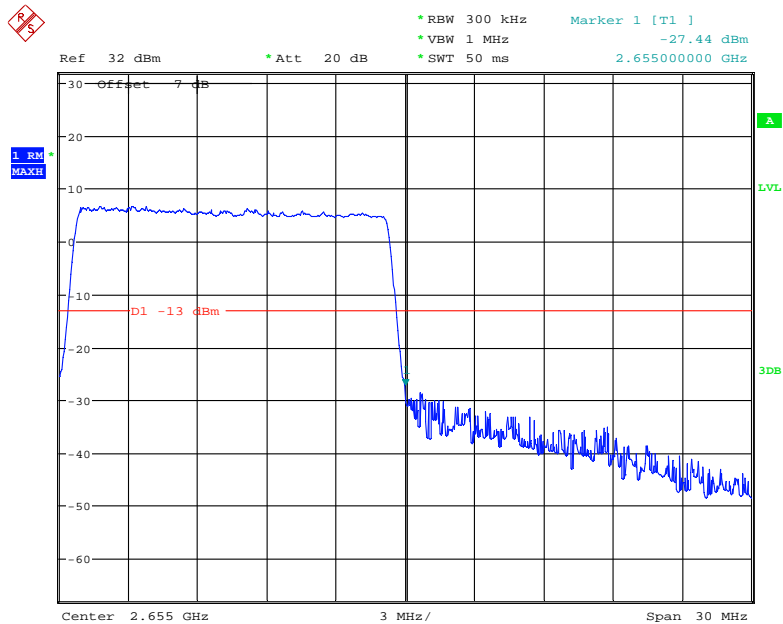

Date: 23.NOV.2020 15:25:09

QPSK (20.0 MHz, FULL RB) - Left Band Edge

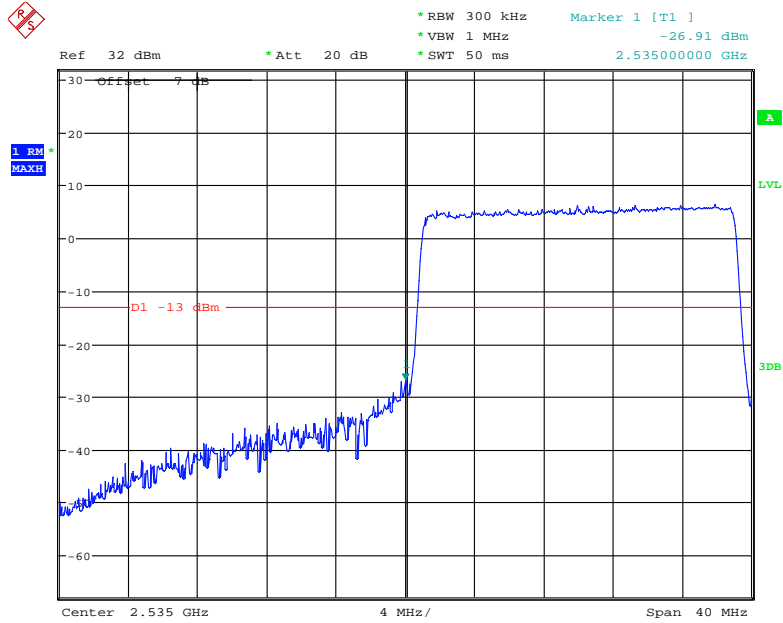

Date: 23.NOV.2020 15:32:22

QPSK (20.0 MHz, FULL RB) - Right Band Edge

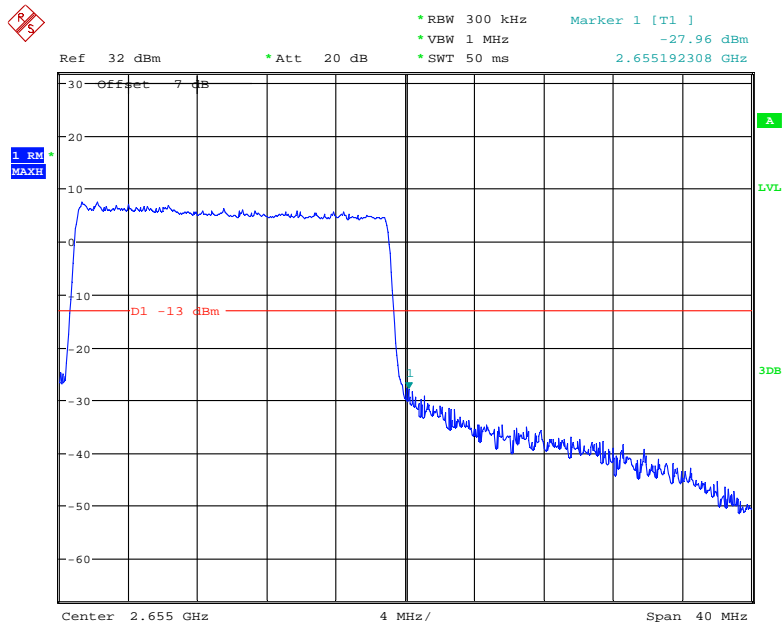

Date: 23.NOV.2020 15:37:05

16-QAM (20.0 MHz, FULL RB) - Left Band Edge

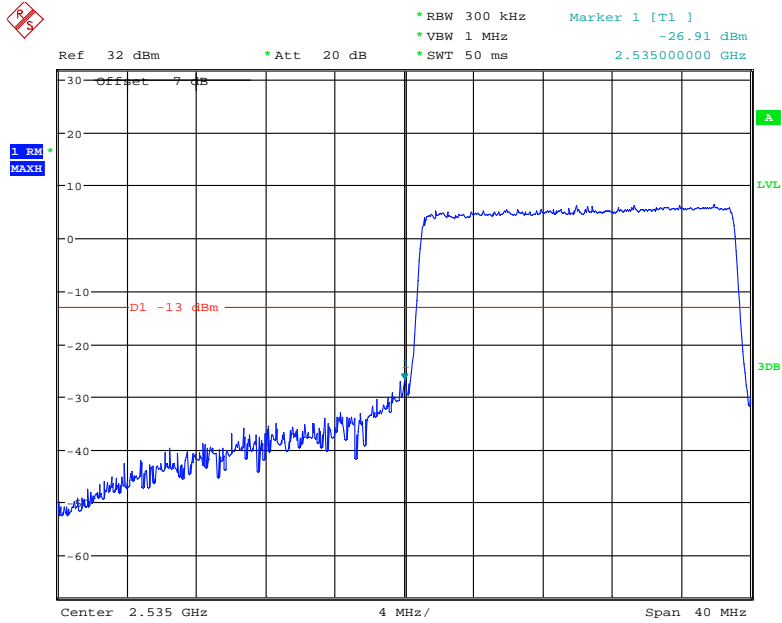

Date: 23.NOV.2020 15:32:22

16-QAM (20.0 MHz, FULL RB) - Right Band Edge

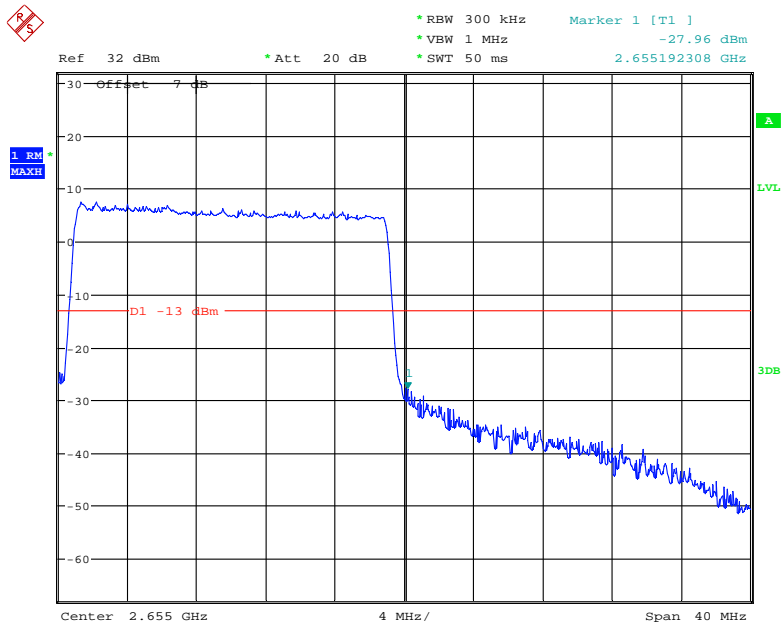

Date: 23.NOV.2020 15:37:05

FCC § 2.1055; § 22.355; § 24.235; §27.54 - FREQUENCY STABILITY

Applicable Standard

FCC § 2.1055, §22.355, §24.235 and §27.54.

According to FCC §2.1055, the frequency stability shall be sufficient to ensure that the fundamental emissions stay within the authorized bands of operation.

According to §22.355, the carrier frequency of each transmitter in the Public Mobile Services must be maintained within the tolerances given in Table below:

Frequency Tolerance for Transmitters in the Public Mobile Services

Frequency Range (MHz)	Base, fixed (ppm)	Mobile ≤ 3 watts (ppm)	Mobile > 3 watts (ppm)
25 to 50	20.0	20.0	50.0
50 to 450	5.0	5.0	50.0
450 to 512	2.5	5.0	5.0
821 to 896	1.5	2.5	2.5
928 to 929.	5.0	N/A	N/A
929 to 960.	1.5	N/A	N/A
2110 to 2220	10.0	N/A	N/A

According to §24.235, the frequency stability shall be sufficient to ensure that the fundamental emissions stays within the authorized frequency block.

Test Procedure

Frequency Stability vs. Temperature: The equipment under test was connected to an external DC power supply and the RF output was connected to communication test set via feed-through attenuators. The EUT was placed inside the temperature chamber. The DC leads and RF output cable exited the chamber through an opening made for the purpose.

After the temperature stabilized for approximately 20 minutes, the frequency output was recorded from the communication test set.

Frequency Stability vs. Voltage: For hand carried, battery powered equipment; reduce primary supply voltage to the battery operating end point which shall be specified by the manufacturer.

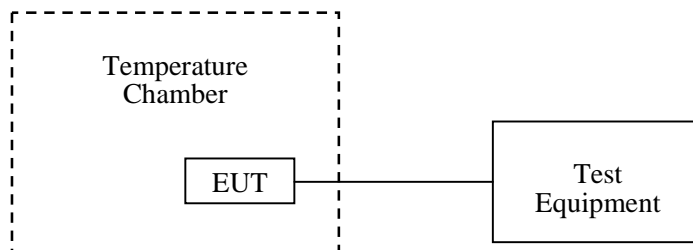

Test Data

Environmental Conditions

Temperature:	25 °C
Relative Humidity:	55 %
ATM Pressure:	101.0 kPa

The testing was performed by Coco Liu on 2020-11-24.

EUT operation mode: Transmitting

Test Result: Pass

Please refer to the following tables.

Cellular Band (Part 22H)

GSM Mode

Middle Channel, $f_0=836.6\text{MHz}$				
Temperature (°C)	Voltage Supplied (V_{DC})	Frequency Error (Hz)	Frequency Error (ppm)	Limit (ppm)
-30	3.85	3	0.0036	2.5
-20		2	0.0024	2.5
-10		0	0.0000	2.5
0		2	0.0024	2.5
10		3	0.0036	2.5
20		5	0.0060	2.5
30		6	0.0072	2.5
40		7	0.0084	2.5
50		3	0.0036	2.5
20		V min.= 3.45	2	0.0024
	V max.= 4.4	2	0.0024	2.5

EDGE Mode

Middle Channel, $f_0 = 836.6\text{MHz}$				
Temperature (°C)	Voltage Supplied (V _{DC})	Frequency Error (Hz)	Frequency Error (ppm)	Limit (ppm)
-30	3.85	4	0.0048	2.5
-20		5	0.0060	2.5
-10		7	0.0084	2.5
0		4	0.0048	2.5
10		6	0.0072	2.5
20		5	0.0060	2.5
30		7	0.0084	2.5
40		6	0.0072	2.5
50		8	0.0096	2.5
20		V min.= 3.45	4	0.0048
	V max.= 4.4	6	0.0072	2.5

WCDMA Mode

Middle Channel, $f_0 = 836.6\text{MHz}$				
Temperature (°C)	Voltage Supplied (V _{DC})	Frequency Error (Hz)	Frequency Error (ppm)	Limit (ppm)
-30	3.85	1	0.0012	2.5
-20		2	0.0024	2.5
-10		-2	-0.0024	2.5
0		1	0.0012	2.5
10		3	0.0036	2.5
20		5	0.0060	2.5
30		7	0.0084	2.5
40		1	0.0012	2.5
50		2	0.0024	2.5
20		V min.= 3.45	3	0.0036
	V max.= 4.4	2	0.0024	2.5

PCS Band (Part 24E)

GSM Mode

Middle Channel, $f_0 = 1880.0$ MHz				
Temperature (°C)	Voltage Supplied (V _{DC})	Frequency Error (Hz)	Frequency Error (ppm)	Result
-30	3.85	-3	-0.0016	pass
-20		4	0.0021	pass
-10		3	0.0016	pass
0		2	0.0011	pass
10		-1	-0.0005	pass
20		-4	-0.0021	pass
30		-3	-0.0016	pass
40		-6	-0.0032	pass
50		-4	-0.0021	pass
20		V min.= 3.45	-3	-0.0016
	V max.= 4.4	-2	-0.0011	pass

EDGE Mode

Middle Channel, $f_0 = 1880.0$ MHz				
Temperature (°C)	Voltage Supplied (V _{DC})	Frequency Error (Hz)	Frequency Error (ppm)	Result
-30	3.85	-2	-0.0011	pass
-20		-6	-0.0032	pass
-10		-5	-0.0027	pass
0		-7	-0.0037	pass
10		-4	-0.0021	pass
20		-1	-0.0005	pass
30		-3	-0.0016	pass
40		-5	-0.0027	pass
50		-4	-0.0021	pass
20		V min.= 3.45	-3	-0.0016
	V max.= 4.4	-6	-0.0032	pass

WCDMA Mode

Middle Channel, $f_0 = 1880.0$ MHz				
Temperature (°C)	Voltage Supplied (V _{DC})	Frequency Error (Hz)	Frequency Error (ppm)	Result
-30	3.85	2	0.0011	pass
-20		4	0.0021	pass
-10		9	0.0048	pass
0		8	0.0043	pass
10		5	0.0027	pass
20		3	0.0016	pass
30		2	0.0011	pass
40		4	0.0021	pass
50		3	0.0016	pass
20		V min.= 3.45	4	0.0021
	V max.= 4.4	2	0.0011	pass

AWS Band (Part 27)

Temperature (°C)	Power Supplied (V _{DC})	F _L (MHz)	F _H (MHz)	F _L Limit (MHz)	F _H Limit (MHz)
-30	3.85	1710.0655	1754.9368	1710	1755
-20		1710.0657	1754.9330	1710	1755
-10		1710.0644	1754.9311	1710	1755
0		1710.0601	1754.9368	1710	1755
10		1710.0622	1754.9338	1710	1755
20		1710.0609	1754.9354	1710	1755
30		1710.0627	1754.9353	1710	1755
40		1710.0651	1754.9345	1710	1755
50		1710.0599	1754.9319	1710	1755
20		V min.= 3.45	1710.0656	1754.9348	1710
	V max.= 4.4	1710.0606	1754.9312	1710	1755

LTE:
QPSK:

Band 2:

10.0 MHz Middle Channel, $f_0=1880\text{MHz}$				
Temperature (°C)	Voltage Supplied (V _{DC})	Frequency Error (Hz)	Frequency Error (ppm)	Result
-30	3.85	-14	-0.0074	pass
-20		-9	-0.0048	pass
-10		-6	-0.0032	pass
0		5	0.0027	pass
10		7	0.0037	pass
20		6	0.0032	pass
30		-7	-0.0037	pass
40		6	0.0032	pass
50		-11	-0.0059	pass
20		V min.= 3.45	-7	-0.0037
	V max.= 4.4	-6	-0.0032	pass

Band 4:

10 MHz Bandwidth					
Temperature (°C)	Power Supplied (V _{DC})	F _L (MHz)	F _H (MHz)	F _L Limit (MHz)	F _H Limit (MHz)
-30	3.85	1710.4004	1754.5614	1710	1755
-20		1710.4168	1754.5350	1710	1755
-10		1710.3989	1754.5297	1710	1755
0		1710.3806	1754.5881	1710	1755
10		1710.4660	1754.5596	1710	1755
20		1710.3995	1754.4954	1710	1755
30		1710.4000	1754.4627	1710	1755
40		1710.4385	1754.5111	1710	1755
50		1710.3888	1754.5530	1710	1755
20		V min.= 3.45	1710.4346	1754.5282	1710
	V max.= 4.4	1710.4659	1754.5906	1710	1755

Band 5:

10.0 MHz Middle Channel, $f_0=836.5\text{MHz}$				
Temperature (°C)	Voltage Supplied (V _{DC})	Frequency Error (Hz)	Frequency Error (ppm)	Limit (ppm)
-30	3.85	-3	-0.0036	2.5
-20		-6	-0.0072	2.5
-10		-6	-0.0072	2.5
0		7	0.0084	2.5
10		10	0.0120	2.5
20		6	0.0072	2.5
30		-8	-0.0096	2.5
40		-7	-0.0084	2.5
50		-7	-0.0084	2.5
20		V min.= 3.45	8	0.0096
	V max.= 4.4	-6	-0.0072	2.5

Band 7:

10 MHz Bandwidth					
Temperature (°C)	Power Supplied (V _{DC})	F _L (MHz)	F _H (MHz)	F _L Limit (MHz)	F _H Limit (MHz)
-30	3.85	2500.4079	2569.5474	2500	2570
-20		2500.5087	2569.4881	2500	2570
-10		2500.4720	2569.5750	2500	2570
0		2500.4894	2569.5212	2500	2570
10		2500.4673	2569.5280	2500	2570
20		2500.4649	2569.5680	2500	2570
30		2500.5106	2569.4457	2500	2570
40		2500.4243	2569.5356	2500	2570
50		2500.4698	2569.5592	2500	2570
20		V min.= 3.45	2500.4104	2569.5144	2500
	V max.= 4.4	2500.4320	2569.4949	2500	2570

Band 38:

10 MHz Bandwidth					
Temperature (°C)	Power Supplied (V _{DC})	F _L (MHz)	F _H (MHz)	F _L Limit (MHz)	F _H Limit (MHz)
-30	3.85	2570.0292	2619.9128	2570	2620
-20		2570.0535	2619.9192	2570	2620
-10		2570.0734	2619.9164	2570	2620
0		2570.0469	2619.9020	2570	2620
10		2570.0118	2619.9584	2570	2620
20		2570.0993	2619.9035	2570	2620
30		2570.0172	2619.9338	2570	2620
40		2570.0840	2619.9977	2570	2620
50		2570.0069	2619.9455	2570	2620
20		V min.= 3.45	2570.0839	2619.9023	2570
	V max.= 4.4	2570.0998	2619.9816	2570	2620

Band 41:

10 MHz Bandwidth					
Temperature (°C)	Power Supplied (V _{DC})	F _L (MHz)	F _H (MHz)	F _L Limit (MHz)	F _H Limit (MHz)
-30	3.85	2535.0748	2654.9233	2535	2655
-20		2535.0508	2654.9871	2535	2655
-10		2535.0389	2654.9086	2535	2655
0		2535.0272	2654.9034	2535	2655
10		2535.0154	2654.9466	2535	2655
20		2535.0702	2654.9044	2535	2655
30		2535.0480	2654.9645	2535	2655
40		2535.0414	2654.9917	2535	2655
50		2535.0927	2654.9794	2535	2655
20		V min.= 3.45	2535.0312	2654.9551	2535
	V max.= 4.4	2535.0259	2654.9783	2535	2655

16QAM:

Band 2:

10.0 MHz Middle Channel, $f_0 = 1880\text{MHz}$				
Temperature (°C)	Voltage Supplied (V _{DC})	Frequency Error (Hz)	Frequency Error (ppm)	Result
-30	3.85	-9	-0.0048	pass
-20		-6	-0.0032	pass
-10		11	0.0059	pass
0		-8	-0.0043	pass
10		-11	-0.0059	pass
20		-10	-0.0053	pass
30		-7	-0.0037	pass
40		-8	-0.0043	pass
50		8	0.0043	pass
20		V min.= 3.45	7	0.0037
	V max.= 4.4	9	0.0048	pass

Band 4:

10 MHz Bandwidth					
Temperature (°C)	Power Supplied (V _{DC})	F _L (MHz)	F _H (MHz)	F _L Limit (MHz)	F _H Limit (MHz)
-30	3.85	1710.3578	1754.5239	1710	1755
-20		1710.4041	1754.5064	1710	1755
-10		1710.5069	1754.5633	1710	1755
0		1710.3406	1754.5774	1710	1755
10		1710.4148	1754.5564	1710	1755
20		1710.4102	1754.5090	1710	1755
30		1710.4143	1754.5497	1710	1755
40		1710.4414	1754.4745	1710	1755
50		1710.4574	1754.6363	1710	1755
20		V min.= 3.45	1710.4285	1754.6002	1710
	V max.= 4.4	1710.4478	1754.5463	1710	1755

Band 5:

10.0 MHz Middle Channel, $f_0 = 836.5\text{MHz}$				
Temperature (°C)	Voltage Supplied (V _{DC})	Frequency Error (Hz)	Frequency Error (ppm)	Limit (ppm)
-30	3.85	-8	-0.0096	2.5
-20		7	0.0084	2.5
-10		-9	-0.0108	2.5
0		8	0.0096	2.5
10		-7	-0.0084	2.5
20		7	0.0084	2.5
30		5	0.0060	2.5
40		-7	-0.0084	2.5
50		-6	-0.0072	2.5
20	V min.= 3.45	5	0.0060	2.5
	V max.= 4.4	-6	-0.0072	2.5

Band 7:

10 MHz Bandwidth					
Temperature (°C)	Power Supplied (V _{DC})	F _L (MHz)	F _H (MHz)	F _L Limit (MHz)	F _H Limit (MHz)
-30	3.85	2500.4794	2569.4722	2500	2570
-20		2500.5106	2569.5630	2500	2570
-10		2500.5066	2569.5336	2500	2570
0		2500.4748	2569.5734	2500	2570
10		2500.5130	2569.5501	2500	2570
20		2500.4391	2569.5237	2500	2570
30		2500.4977	2569.4932	2500	2570
40		2500.4741	2569.5283	2500	2570
50		2500.4427	2569.5697	2500	2570
20	V min.= 3.45	2500.4173	2569.5525	2500	2570
	V max.= 4.4	2500.4529	2569.5062	2500	2570

Band 38:

10 MHz Bandwidth					
Temperature (°C)	Power Supplied (V _{DC})	F _L (MHz)	F _H (MHz)	F _L Limit (MHz)	F _H Limit (MHz)
-30	3.85	2570.0367	2619.9325	2570	2620
-20		2570.0311	2619.9335	2570	2620
-10		2570.0327	2619.9350	2570	2620
0		2570.0333	2619.9336	2570	2620
10		2570.0320	2619.9312	2570	2620
20		2570.0313	2619.9347	2570	2620
30		2570.0309	2619.9295	2570	2620
40		2570.0318	2619.9305	2570	2620
50		2570.0299	2619.9324	2570	2620
20	V min.= 3.45	2570.0369	2619.9361	2570	2620
	V max.= 4.4	2570.0332	2619.9344	2570	2620

Band 41:

10 MHz Bandwidth					
Temperature (°C)	Power Supplied (V _{DC})	F _L (MHz)	F _H (MHz)	F _L Limit (MHz)	F _H Limit (MHz)
-30	3.85	2535.0401	2654.9042	2535	2655
-20		2535.0541	2654.9795	2535	2655
-10		2535.0625	2654.9875	2535	2655
0		2535.0130	2654.9165	2535	2655
10		2535.0130	2654.9936	2535	2655
20		2535.0036	2654.9732	2535	2655
30		2535.0022	2654.9766	2535	2655
40		2535.0901	2654.9253	2535	2655
50		2535.0624	2654.9302	2535	2655
20	V min.= 3.45	2535.0840	2654.9592	2535	2655
	V max.= 4.4	2535.0274	2654.9054	2535	2655

***** END OF REPORT *****