



TEST REPORT

FCC ID: 2AIZN-X609B

Product: Mobile Phone

Model No.: X609B

Additional Model No.: N/A

Trade Mark: Infinix

Report No.: FCC18080068A-15B

Issued Date: Oct. 16, 2018

Issued for:

INFINIX MOBILITY LIMITED

**RMS 05-15, 13A/F SOUTH TOWER WORLD FINANCE CTR HARBOUR CITY 17
CANTON RD TST KLN HONG KONG**

Issued By:

World Standardization Certification & Testing Group Co., Ltd.

Building A-B, Baoshi Science & Technology Park, Baoshi Road,

Bao'an District, Shenzhen, Guangdong, China

TEL: +86-755-26996192

FAX: +86-755-86376605

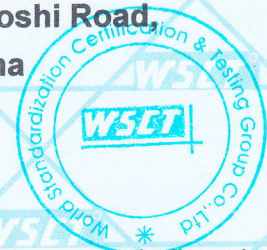

Note: The results contained in this report pertain only to the tested sample. This report shall not be reproduced, except in full, without written approval of World Standardization Certification & Testing Group Co.,Ltd. This report must not be used by the client to claim product certification, approval, or endorsement by NVLAP, NIST, or any agency of the U.S. Government.





Table of Contents

Page

1. GENERAL INFORMATION	3
2. GENERAL DESCRIPTION OF EUT	4
2.1. TEST DESCRIPTION	5
3. SUMMARY OF TEST RESULTS	9
4. MEASUREMENT INSTRUMENTS	10
5. EMC EMISSION TEST	11
5.1 CONDUCTED EMISSION MEASUREMENT	11
5.2 RADIATED EMISSION MEASUREMENT	15





1. GENERAL INFORMATION

Product:	Mobile phone
Model No.:	X609B
Additional Model:	N/A
Applicant:	INFINIX MOBILITY LIMITED
Address:	RMS 05-15, 13A/F SOUTH TOWER WORLD FINANCE CTR HARBOUR CITY 17 CANTON RD TST KLN HONG KONG
Manufacturer:	SHENZHEN TECNO TECHNOLOGY CO.,LTD.
Address:	1/F-4/F,7/F, BUILDING 3, TAIPINGYANG INDUSTRIAL ZONE, NO.2088, SHENYAN ROAD, YANTIAN DISTRICT, SHENZHEN CITY, GUANGDONG PROVINCE, P.R.C
Data of receipt:	Sep. 26, 2018
Date of Test:	Sep. 26, 2018 to Oct. 15, 2018
Applicable Standards:	FCC Rules Part15 Subpart B. ANSI C63.4-2014 .

The above equipment has been tested by World Standardization Certification & Testing Group Co., Ltd. and found compliance with the requirements set forth in the technical standards mentioned above. The results of testing in this report apply only to the product/system, which was tested. Other similar equipment will not necessarily produce the same results due to production tolerance and measurement uncertainties.

Tested By: Pu Shixi
(Pu Shixi)

Date: Oct. 16, 2018

Check By: Qin Shuiquan
(Qin Shuiquan)

Date: Oct. 16, 2018

Approved By: Wang Fengbing
(Wang Fengbing)

Date: Oct. 16, 2018





2. GENERAL DESCRIPTION OF EUT

Equipment Type:	Mobile Phone
Test Model:	X609B
Additional Model:	N/A
Trade Mark:	Infinix
Applicant:	INFINIX MOBILITY LIMITED
Address:	RMS 05-15, 13A/F SOUTH TOWER WORLD FINANCE CTR HARBOUR CITY 17 CANTON RD TST KLN HONG KONG
Manufacturer:	SHENZHEN TECNO TECHNOLOGY CO.,LTD.
Address:	1/F-4/F,7/F, BUILDING 3, TAIPINGYANG INDUSTRIAL ZONE, NO.2088, SHENYAN ROAD, YANTIAN DISTRICT, SHENZHEN CITY, GUANGDONG PROVINCE, P.R.C
Hardware version:	V2.0
Software version:	X609B-H8025C-GO-180911V46
Extreme Temp. Tolerance:	-10°C to +65°C
Battery information:	Li-Polymer Battery : BL-34BX Voltage: 3.8V Rated Capacity: 3400mAh/12.92Wh Typical Capacity: 3500mAh/13.30Wh Limited Charge Voltage: 4.35V
Adapter Information:	Adapter: CU-52JT Input: AC 100-240V 50/60Hz 200mA Output: DC 5V 1.2A
Deviation	None
Condition of Test Sample	Normal





2.1. TEST DESCRIPTION

2.1.1 MEASUREMENT UNCERTAINTY

The reported uncertainty of measurement $y \pm U$, where expanded uncertainty U is based on a standard uncertainty multiplied by a coverage factor of $k=2$, providing a level of confidence of approximately 95%.

No.	Item	Uncertainty
1	Conducted Emission Test	$\pm 3.2\text{dB}$
2	RF power, conducted	$\pm 0.16\text{dB}$
3	Spurious emissions, conducted	$\pm 0.21\text{dB}$
4	All emissions, radiated(<1G)	$\pm 4.7\text{dB}$
5	All emissions, radiated(>1G)	$\pm 4.7\text{dB}$
6	Temperature	$\pm 0.5^\circ\text{C}$
7	Humidity	$\pm 2\%$





2.1.2 DESCRIPTION OF TEST MODES

To investigate the maximum EMI emission characteristics generates from EUT, the test system was pre-scanning tested base on the consideration of following EUT operation mode or test configuration mode which possible have effect on EMI emission level. Each of these EUT operation mode(s) or test configuration mode(s) mentioned above was evaluated respectively.

Pretest Mode	Description
Mode 1	Video Recording
Model 2	Video Playing
Mode 3	Exchange data with computer
Mode 4	FM

For Conducted Emission	
Final Test Mode	Test with Keyboard and Mouse
Mode 1	Video Recording
Model 2	Video Playing
Mode 3	Exchange data with computer
Mode 4	FM

For Radiated Emission	
Final Test Mode	Test with Keyboard and Mouse
Mode 1	Video Recording
Model 2	Video Playing
Mode 3	Exchange data with computer
Mode 4	FM





2.1.3 CONFIGURATION OF SYSTEM UNDER TEST

Mode 1&2&4&5:

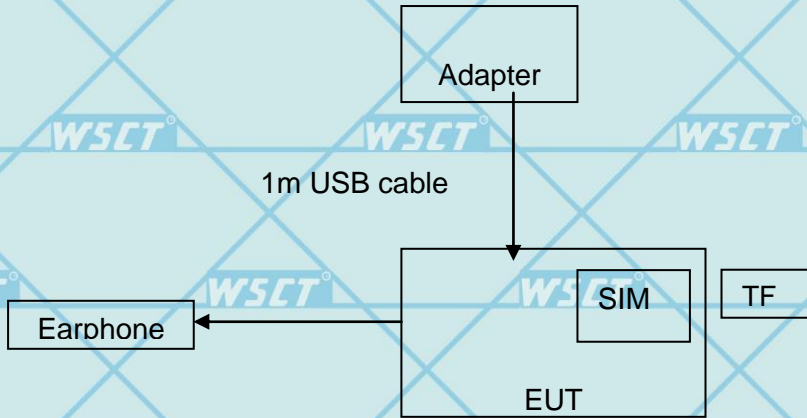

Mode 3:

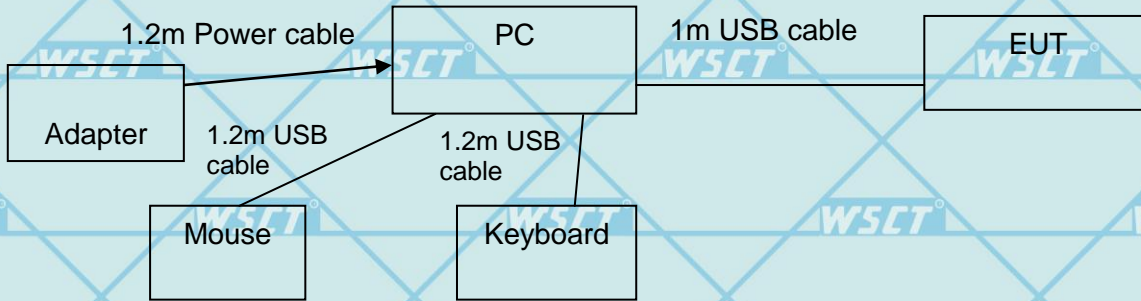

(EUT: Mobile phone)

I/O Port of EUT			
I/O Port Type	Q'TY	Cable	Tested with
Power	1	1m USB cable, unshielded	1
Earphone	1	1m USB cable, unshielded	1





2.1.4 DESCRIPTION OF SUPPORT UNITS (CONDUCTED MODE)

The EUT has been tested as an independent unit together with other necessary accessories or support units. The following support units or accessories were used to form a representative test configuration during the tests.

Item	Equipment	Mfr/Brand	Model/Type No.	Series No.	Note
1	Adapter	/	CU-52JT	/	/
2	Keyboard	HP	SK-2880	435302-AA-	/
3	Mouse	DELL	MS111-1	/	/

Note:

- (1) The support equipment was authorized by Declaration of Confirmation.
- (2) For detachable type I/O cable should be specified the length in cm in 『Length』 column.





3. SUMMARY OF TEST RESULTS

Test procedures according to the technical standards:

FCC Part15 , Subpart B			
Standard Section	Test Item	Judgment	Remark
15.107	CONDUCTED EMISSION	PASS	
15.109	RADIATED EMISSION	PASS	

NOTE:

(1) "N/A" denotes test is not applicable in this test report.





4. MEASUREMENT INSTRUMENTS

Kind of Equipment	Manufacturer	Type No.	Serial No.	Last Calibrated	Calibrated until
ESCI Test Receiver	R&S	ESCI	100005	08/19/2018	08/18/2019
LISN	AFJ	LS16	16010222119	08/19/2018	08/18/2019
LISN(EUT)	Mestec	AN3016	04/10040	08/19/2018	08/18/2019
pre-amplifier	CDSI	PAP-1G18-38	--	08/19/2018	08/18/2019
System Controller	CT	SC100	-	08/19/2018	08/18/2019
Bi-log Antenna	Chase	CBL6111C	2576	08/19/2018	08/18/2019
Spectrum analyzer	R&S	FSU26	200409	08/19/2018	08/18/2019
Horn Antenna	SCHWARZBECK	9120D	1141	08/19/2018	08/18/2019
Bi-log Antenna	SCHWARZBECK	VULB9163	9163/340	08/19/2018	08/18/2019
Pre Amplifier	H.P.	HP8447E	2945A02715	10/13/2018	10/12/2019
9*6*6 Anechoic	--	--	--	08/21/2018	08/20/2019





5. EMC EMISSION TEST

5.1 CONDUCTED EMISSION MEASUREMENT

5.1.1 POWER LINE CONDUCTED EMISSION Limits (Frequency Range 150KHz-30MHz)

FREQUENCY (MHz)	Class A (dBuV)		Class B (dBuV)		Standard
	Quasi-peak	Average	Quasi-peak	Average	
0.15 -0.5	79.00	66.00	66 - 56 *	56 - 46 *	FCC
0.50 -5.0	73.00	60.00	56.00	46.00	FCC
5.0 -30.0	73.00	60.00	60.00	50.00	FCC

Note:

- (1) The tighter limit applies at the band edges.
- (2) The limit of " * " marked band means the limitation decreases linearly with the logarithm of the frequency in the range.

The following table is the setting of the receiver

Receiver Parameters	Setting
Attenuation	10 dB
Start Frequency	0.15 MHz
Stop Frequency	30 MHz
IF Bandwidth	9 kHz





5.1.2 TEST PROCEDURE

- a. The EUT was placed 0.4 meters from the horizontal ground plane with EUT being connected to the power mains through a line impedance stabilization network (LISN). All other support equipments powered from additional LISN(s). The LISN provide 50 Ohm/ 50uH of coupling impedance for the measuring instrument.
- b. Interconnecting cables that hang closer than 40 cm to the ground plane shall be folded back and forth in the center forming a bundle 30 to 40 cm long.
- c. I/O cables that are not connected to a peripheral shall be bundled in the center. The end of the cable may be terminated, if required, using the correct terminating impedance. The overall length shall not exceed 1 m.
- d. LISN at least 80 cm from nearest part of EUT chassis.
- e. For the actual test configuration, please refer to the related Item –EUT Test Photos.

5.1.3 DEVIATION FROM TEST STANDARD

No deviation

5.1.4 TEST SETUP

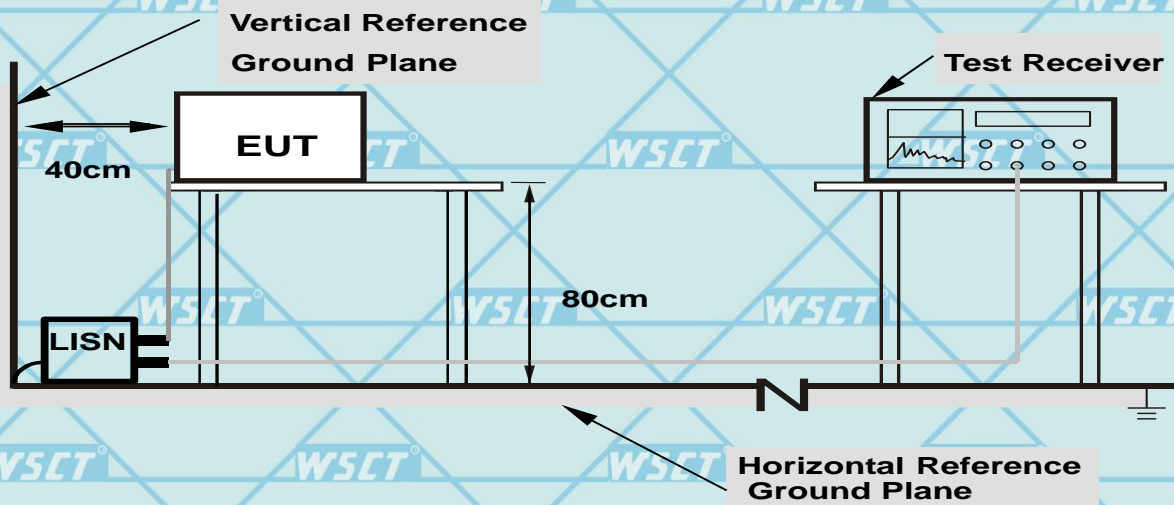

**Note: 1.Support units were connected to second LISN.
2.Both of LISNs (AMN) are 80 cm from EUT and at least 80 from other units and other metal planes**

5.1.5 EUT OPERATING CONDITIONS

The EUT was configured for testing in a typical fashion (as a customer would normally use it). The EUT has been programmed to continuously transmit during test. This operating condition was tested and used to collect the included data.





For Question,
Please Contact with WSCT
www.wsct-cert.com

5.1.6 TEST RESULTS

This is the worst pattern data

Temperature	26 °C	Relative Humidity	54%
Pressure	1010hPa	Phase	L/N
Test Mode	Mode 3		

L:

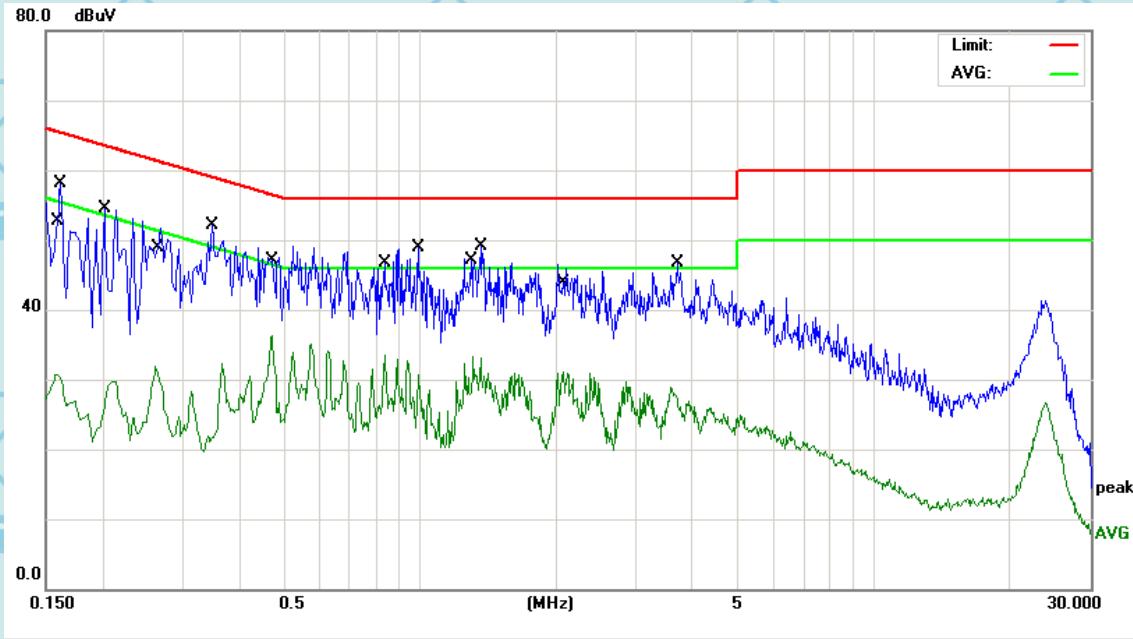

No.	Mk.	Freq. MHz	Reading Level dBuV	Correct Factor dB	Measure- ment dBuV	Limit dBuV	Over dB	Detector
1		0.1620	47.73	10.44	58.17	65.36	-7.19	QP
2		0.2620	25.41	10.43	35.84	51.36	-15.52	AVG
3		0.4740	36.91	10.40	47.31	56.44	-9.13	QP
4	*	0.4740	32.39	10.40	42.79	46.44	-3.65	AVG
5		0.8420	36.17	10.36	46.53	56.00	-9.47	QP
6		0.8900	29.98	10.35	40.33	46.00	-5.67	AVG
7		1.3099	32.76	10.32	43.08	56.00	-12.92	QP
8		1.3099	28.25	10.32	38.57	46.00	-7.43	AVG
9		2.0500	30.00	10.29	40.29	56.00	-15.71	QP
10		2.0660	26.59	10.29	36.88	46.00	-9.12	AVG
11		23.8420	26.02	10.10	36.12	60.00	-23.88	QP
12		23.8420	21.02	10.10	31.12	50.00	-18.88	AVG





For Question, contact with WSCT
wsc-cert.com

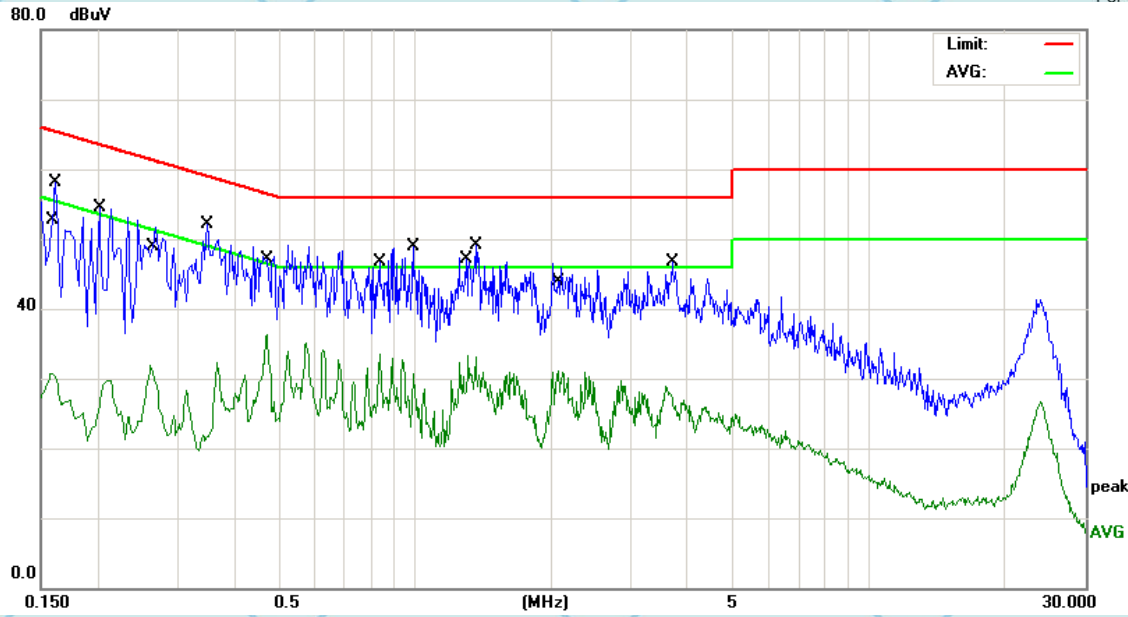

No.	Mk.	Freq. MHz	Reading Level dBuV	Correct Factor dB	Measure- ment dBuV	Limit dBuV	Over dB	Detector
1		0.1580	20.32	10.44	30.76	55.56	-24.80	AVG
2		0.1620	43.25	10.44	53.69	65.36	-11.67	QP
3		0.2020	26.34	10.43	36.77	63.52	-26.75	QP
4		0.2620	21.48	10.43	31.91	51.36	-19.45	AVG
5		0.3500	19.88	10.42	30.30	58.96	-28.66	QP
6	*	0.4740	25.91	10.40	36.31	46.44	-10.13	AVG
7		0.8380	23.11	10.36	33.47	46.00	-12.53	AVG
8		0.9940	28.36	10.34	38.70	56.00	-17.30	QP
9		1.3099	23.07	10.32	33.39	46.00	-12.61	AVG
10		1.3619	28.85	10.32	39.17	56.00	-16.83	QP
11		2.0660	20.89	10.29	31.18	46.00	-14.82	AVG
12		3.6820	26.40	10.26	36.66	56.00	-19.34	QP

Note: 1.All the modes have been investigated, and only worst mode is presented in this report.
2.Over=Reading Level + Correct Factor - Limit.





5.2 RADIATED EMISSION MEASUREMENT

5.2.1 Radiated Emission Limits (Frequency Range 9kHz-1000MHz)

The field strength of radiated emissions from unintentional radiators at a distance of 3 meters shall not exceed the following values:

Frequencies (MHz)	Field Strength (microvolts/meter)	Measurement Distance (meters)
0.009~0.490	2400/F(KHz)	300
0.490~1.705	24000/F(KHz)	30
1.705~30.0	30	30
30~88	100	3
88~216	150	3
216~960	200	3
Above 960	500	3

LIMITS OF RADIATED EMISSION MEASUREMENT (Above 1000MHz)

FREQUENCY (MHz)	Limit (dBuV/m) (at 3M)	
	PEAK	AVERAGE
Above 1000	74	54

Notes:

- (1) The limit for radiated test was performed according to FCC PART 15B.
- (2) The tighter limit applies at the band edges.
- (3) Emission level (dBuV/m)=20log Emission level (uV/m).

Spectrum Parameter	Setting
Attenuation	Auto
Start Frequency	1000 MHz
Stop Frequency	10th carrier harmonic
RB / VB (emission in restricted band)	1 MHz / 1 MHz for Peak, 1 MHz / 1Hz for Average

Receiver Parameter	Setting
Attenuation	Auto
Start ~ Stop Frequency	9kHz~150kHz / RB 200Hz for QP
Start ~ Stop Frequency	150kHz~30MHz / RB 9kHz for QP
Start ~ Stop Frequency	30MHz~1000MHz / RB 120kHz for QP





5.2.2 TEST PROCEDURE

- a. The measuring distance of at 3 m shall be used for measurements at frequency up to 1GHz. For frequencies above 1GHz, any suitable measuring distance may be used.
- b. The EUT was placed on the top of a rotating table 0.8 meters above the ground at a 3 meter open area test site. The table was rotated 360 degrees to determine the position of the highest radiation.
- c. The height of the equipment or of the substitution antenna shall be 0.8 m; the height of the test antenna shall vary between 1 m to 4 m. Both horizontal and vertical polarizations of the antenna are set to make the measurement.
- d. The initial step in collecting conducted emission data is a spectrum analyzer peak detector mode pre-scanning the measurement frequency range. Significant peaks are then marked and then Quasi Peak detector mode re-measured.
- e. If the Peak Mode measured value compliance with and lower than Quasi Peak Mode Limit, the EUT shall be deemed to meet QP Limits and then no additional QP Mode measurement performed.
- f. For the actual test configuration, please refer to the related Item –EUT Test Photos.

Note:

Both horizontal and vertical antenna polarities were tested and performed pretest to three orthogonal axis. The worst case emissions were reported

5.2.3 DEVIATION FROM TEST STANDARD

No deviation





5.2.4 TEST SETUP

(A) Radiated Emission Test-Up Frequency 30MHz~1GHz

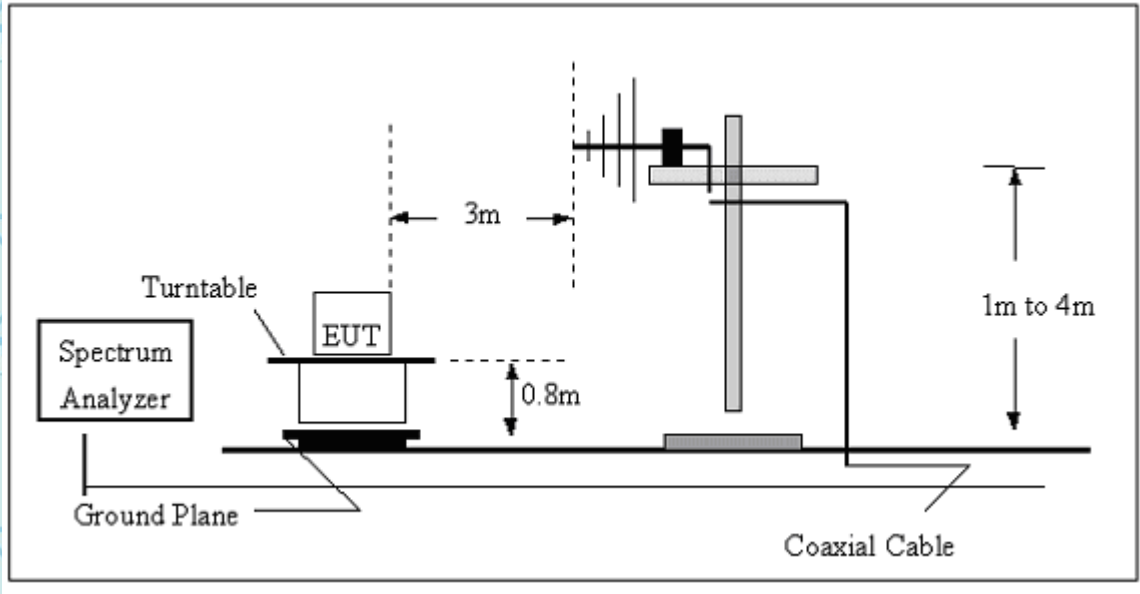

(B) Radiated Emission Test-Up Frequency Above 1GHz

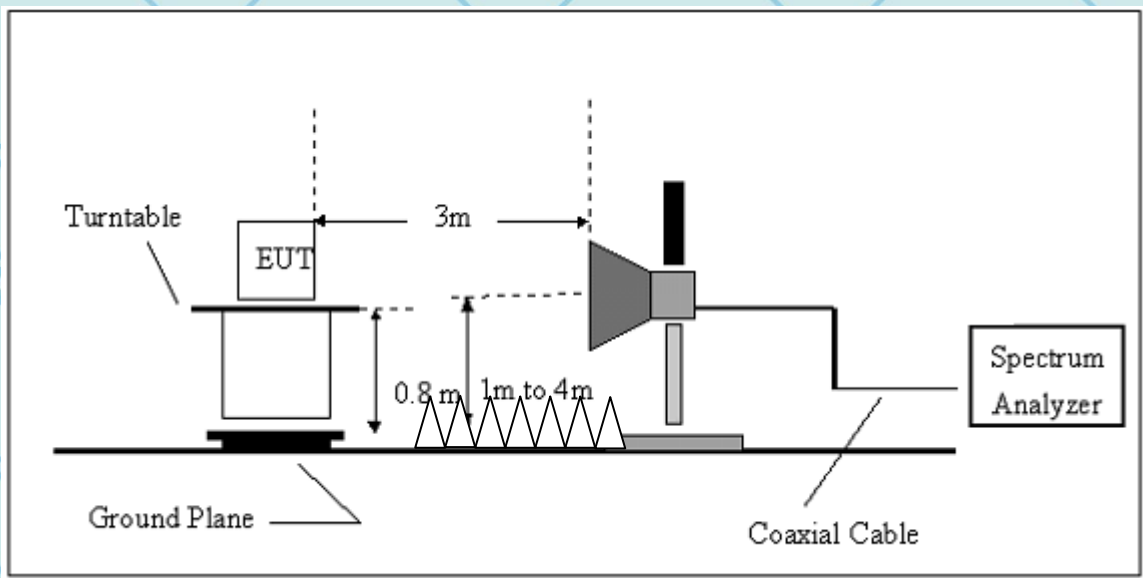

5.2.5 EUT OPERATING CONDITIONS

The EUT tested system was configured as the statements of 2.4 Unless otherwise a special operating condition is specified in the follows during the testing.





5.2.5.1 TEST RESULTS (Between 30M – 1000 MHz)

This is the worst pattern data

Temperature	20 °C	Relative Humidity	48%
Pressure	1010 hPa	Polarization :	Horizontal/Vertical
Test Mode	Mode 3		

H:

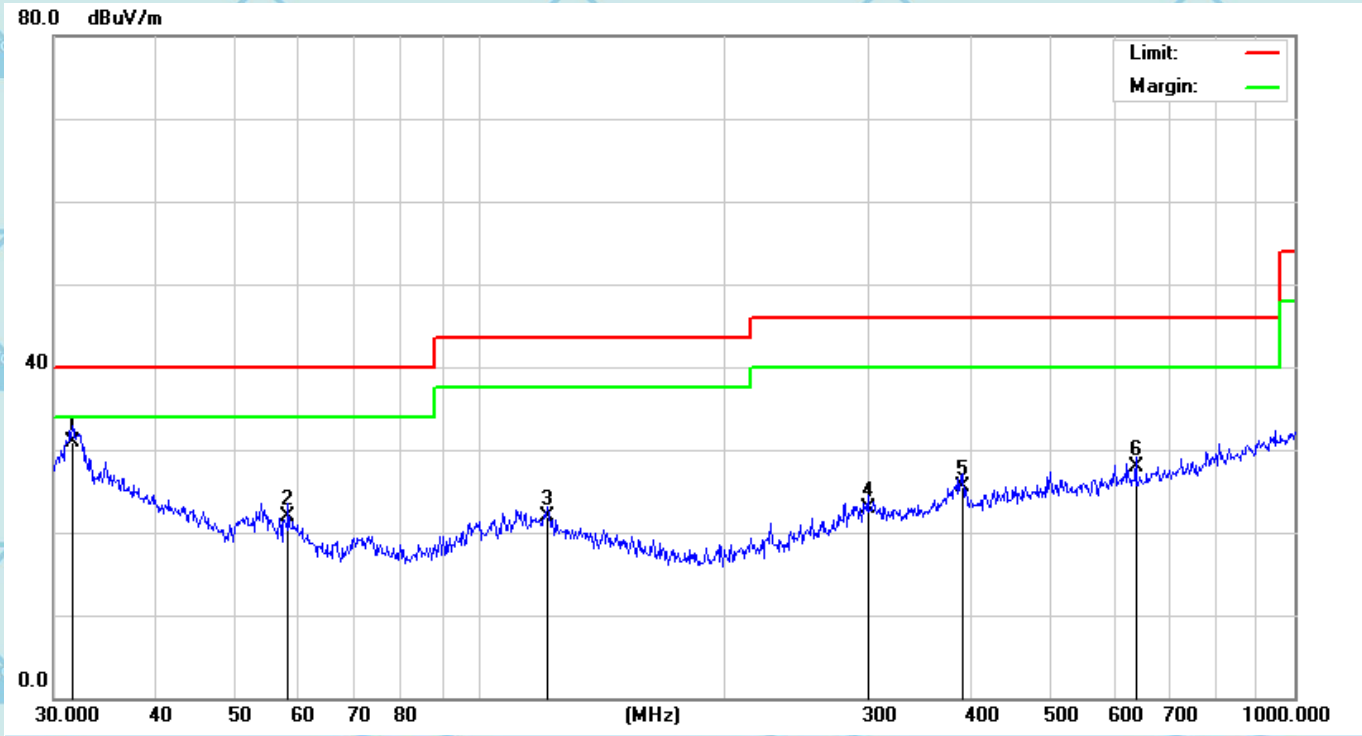

No.	Mk.	Freq. MHz	Reading Level dBuV	Correct Factor dB	Measure- ment dBuV/m	Limit dBuV/m	Over dB	Detector
1	*	31.6202	26.71	4.17	30.88	40.00	-9.12	QP
2		58.2030	27.84	-6.00	21.84	40.00	-18.16	QP
3		121.1231	24.77	-2.91	21.86	43.50	-21.64	QP
4		299.3158	25.13	-2.27	22.86	46.00	-23.14	QP
5		392.0951	27.03	-1.56	25.47	46.00	-20.53	QP
6		638.3686	26.53	1.40	27.93	46.00	-18.07	QP





V:

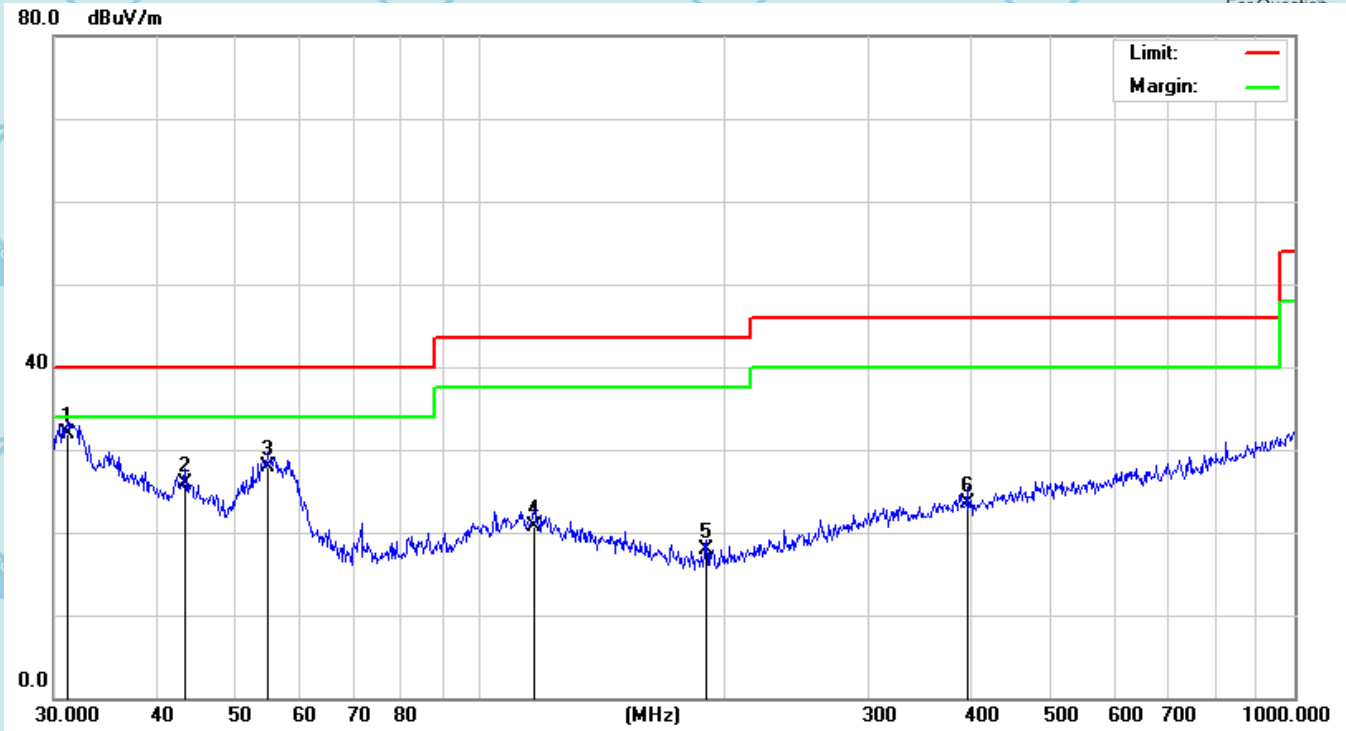

No.	Mk.	Freq. MHz	Reading Level dBuV	Correct Factor dB	Measure- ment dBuV/m	Limit dBuV/m	Over dB	Detector
1	*	31.1798	27.52	4.34	31.86	40.00	-8.14	QP
2		43.5057	27.38	-1.45	25.93	40.00	-14.07	QP
3		54.8348	33.53	-5.59	27.94	40.00	-12.06	QP
4		116.5401	23.24	-2.50	20.74	43.50	-22.76	QP
5		189.7385	25.13	-7.19	17.94	43.50	-25.56	QP
6		396.2415	24.63	-1.07	23.56	46.00	-22.44	QP

Note: 1.All the modes have been investigated, and only worst mode is presented in this report.
2.Over=Reading Level+ Correct Factor - Limit.





5.2.5.2 TEST RESULTS (1GHz to 25GHz)

This is the worst pattern data

Temperature	20 °C	Relative Humidity	48%
Pressure	1010 hPa	Test Mode	Mode 3

Freq. (MHz)	Ant. Pol. H/V	Emission Level(dBuV)		Limit 3m(dBuV/m)		Over(dB)	
		PK	AV	PK	AV	PK	AV
1463.21	V	60.78	40.22	74	54	-13.22	-13.78
2546.62	V	58.73	40.89	74	54	-15.27	-13.11
1693.21	H	59.11	40.17	74	54	-14.89	-13.83
2318.35	H	58.69	39.69	74	54	-15.31	-14.31

Remark:

All emissions not reported were more than 20dB below the specified limit or in the noise floor.
Factor = Antenna Factor + Cable Loss – Pre-amplifier.
All the x/y/z orientation has been investigated, and only worst case is presented in this report.

---END OF REPORT---

