

FCC SAR Compliance Test Report

For

INFINIX MOBILITY LIMITED

RMS 05-15, 13A/F SOUTH TOWER WORLD FINANCE CTR HARBOUR CITY 17 CANTON

RD TST KLN HONG KONG

Model: X521

Test Engineer: Mist Peng

Report Number: WSCT-R&E16053699A-SAR

Report Date: 2016-06-08

Check By: Mark Cheng

Mark Cheng

Approved By: Michal Ling

Michal Ling

Prepared By:

World Standardization Certification & Testing
(Shenzhen)Co., Ltd.

Building A, Baoshi Science & Technology Park, Baoshi
Road, Bao'an District, Shenzhen, Guangdong, China

Tel: +86-755-26996192

Fax: +86-755-26996253

Table of contents

1 General information5

1.1 Notes5

1.2 Application details5

1.3 Statement of Compliance.....6

1.4 EUT Information7

2 Testing laboratory9

3 Test Environment9

4 Applicant and Manufacturer9

5 Test standard/s:10

5.1 RF exposure limits11

5.2 SAR Definition11

6 SAR Measurement System12

6.1 The Measurement System12

6.2 Robot.....13

6.3 Probe13

6.4 Measurement procedure14

6.5 Description of interpolation/extrapolation scheme.....14

6.6 Phantom.....15

6.7 Device Holder16

6.8 Video Positioning System.....17

6.9 Tissue simulating liquids: dielectric properties18

6.10 Tissue simulating liquids: parameters19

7 System Check.....20

7.1 System check procedure20

7.2 System check results21

8 SAR Test Test Configuration22

8.1 GSM Test Configurations.....22

8.2 Wi-Fi Test Configuration22

9 Detailed Test Results.....23

9.1 Conducted Power measurements.....23

9.1.1 Conducted Power of GSM850.....23

9.1.2 Conducted Power of GSM1900.....24

9.1.3 Conducted Power of UMTS Band II.....25

9.1.4 Conducted Power of UMTS Band IV26

9.1.5 Conducted Power of UMTS Band V27

9.1.6 Conducted Power of LET Band II28

9.1.7 Conducted Power of LET Band IV.....28

9.1.8 Conducted Power of LET Band VII.....29

9.1.9 Conducted Power of LET Band XX29

9.1.10 Conducted Power of LET Band XXVIII.....30

9.1.11 Conducted Power of Wi-Fi 2.4G31

9.1.12 Conducted Power of BT31

9.2 SAR test results32

9.2.1 Results overview of GSM850.....33

9.2.2 Results overview of GSM1900.....34

9.2.3 Results overview of Wi-Fi 2.4G35

9.2.4 Results overview of UMTS Band II.....36

9.2.5 Results overview of UMTS Band IV37

9.2.6 Results overview of UMTS Band V38

9.2.7 Results overview of LTE Band II39

9.2.8 Results overview of LTE Band IV40

9.2.9 Results overview of LTE Band VII.....41

9.2.10 Results overview of LTE Band XX42

9.2.11 Results overview of LTE Band XXVIII.....43

10 Multiple Transmitter Information.....44

10.1.1 Stand-alone SAR test exclusion.....45

10.1.2 Simultaneous Transmission Possibilities.....46

10.1.3 SAR Summation Scenario47

11 Measurement uncertainty evaluation55

11.1 Measurement uncertainty evaluation for SAR test55

11.2 Measurement uncertainty evaluation for system check.....56

12 Test equipment and ancillaries used for tests57

Annex A: System performance verification.....58

Annex B: Measurement results.....58

Annex C: Calibration reports58

Annex D: Photo documentation.....59

Modified History

REV.	Modification Description	Issued Date	Remark
REV.1.0	Initial Test Report Release	2016-06-24	Mist Peng

1 General information

1.1 Notes

The test results of this test report relate exclusively to the test item specified in this test report. Shenzhen Timeway Testing Laboratories does not assume responsibility for any conclusions and generalisations drawn from the test results with regard to other specimens or samples of the type of the equipment represented by the test item. The test report is not to be reproduced or published in full without the prior written permission.

1.2 Application details

Date of receipt of test item: 2016-06-22
Start of test: 2016-06-22
End of test: 2016-06-22

1.3 Statement of Compliance

The maximum results of Specific Absorption Rate (SAR) found during testing for X521 is as below:

Band	Position	MAX Reported SAR _{1g} (W/kg)
GSM850	Head	0.407
	Hotspot 10mm	0.560
GSM1900	Head	0.160
	Hotspot 10mm	0.976
UMTS Band II	Head	0.201
	Hotspot 10mm	0.915
UMTS Band IV	Head	0.244
	Hotspot 10mm	0.289
UMTS Band V	Head	0.290
	Hotspot 10mm	0.295
LTE Band II	Head	0.091
	Hotspot 10mm	0.979
LTE Band IV	Head	0.113
	Hotspot 10mm	0.950
LTE Band VII	Head	0.091
	Hotspot 10mm	0.881
LTE Band XX	Head	0.075
	Hotspot 10mm	0.808
LTE Band XXVIII	Head	0.112
	Hotspot 10mm	0.929
Wi-Fi 2450	Head	0.876
	Hotspot 10mm	0.426
The highest simultaneous SAR is 1.28W/kg per KDB690783 D01		

The device is in compliance with Specific Absorption Rate (SAR) for general population/uncontrolled exposure limits of 1.6 W/Kg as averaged over any 1g tissue according to the FCC rule §2.1093, the ANSI/IEEE C95.1:2005, the NCRP Report Number 86 for uncontrolled environment, according to the Industry Canada Radio Standards Specification RSS-102 for General Population/Uncontrolled exposure, and had been tested in accordance with the measurement methods and procedures specified in IEEE Std 1528-2003 & IEEE Std 1528a-2005.

1.4 EUT Information

Device Information:			
Product Type:	Mobile Phone		
Model:	X521		
Device Type:	Portable device		
Exposure Category:	uncontrolled environment / general population		
Production Unit or Identical Prototype:	Production Unit		
Hardware version:	X521-J5086-B1-M-20160502		
Software version :	V1.2		
Antenna Type :	Internal Antenna		
Device Operating Configurations:			
Supporting Mode(s) :	GSM850/1900, UMTS Band II /IV/V,Wi-Fi , BT		
Modulation:	GMSK, OFDM/CCK, GFSK/π/4-DQPSK/ 8-DPSK		
Device Class :	Class B, No DTM Mode		
Operating Frequency Range(s)	Band	TX(MHz)	RX(MHz)
	GSM850	824~849	869~894
	GSM1900	1850~1910	1930~1990
	UMTS Band II	1850~1910	1930~1990
	UMTS Band IV	1710~1755	2110~2155
	UMTS Band V	824~840	869~894
	LTE Band II	1850~1910	1930~1990
	LTE Band IV	1710~1755	2110~2155
	LTE Band VII	2500~2570	2620~2690
	LTE Band XX	832~862	791~821
	LTE Band XXVIII	703~748	758~803
	Wi-Fi	2412~2462	2412~2462
	BT	2402~2480	2402~2480
GPRS class level:	GPRS class 12		
Test Channels (low-mid-high):	128-190-251(GSM850)		
	512-661-810(GSM1900)		
	9262-9400-9538(UMTS Band II)		
	1312-1413-1513(UMTS Band IV)		
	4132-4182-4233(UMTS Band V)		

	18700-18900-19100(LTE Band II)
	20050-20175-20300(LTE Band IV)
	20850-21100-21350(LTE Band VII)
	24225-24230-24245(LTE Band XX)
	27535-27540-27560(LTE Band XXVIII)
	1-6-11 (Wi-Fi)
	0-39-78(BT)
Power Source:	3.8 VDC/1800mAh Rechargeable Battery

2 Testing laboratory

Test Site	World Standardization Certification & Testing CO., LTD.
Test Location	Building A, Baoshi Science & Technology Park, Baoshi Road, Bao'an District, Shenzhen, Guangdong, China
Telephone	+86-755-26996192
Fax	+86-755-26996253
State of accreditation	The Test laboratory (area of testing) is accredited according to ISO/IEC 17025. CNAS Registration number:L3732

3 Test Environment

	Required	Actual
Ambient temperature:	18 – 25 °C	22 ± 2 °C
Tissue Simulating liquid:	22 ± 2 °C	22 ± 2 °C
Relative humidity content:	30 – 70 %	30 – 70 %

4 Applicant and Manufacturer

Applicant/Client Name:	INFINIX MOBILITY LIMITED
Applicant Address:	RMS 05-15, 13A/F SOUTH TOWER WORLD FINANCE CTR HARBOUR CITY 17 CANTON RD TST KLN HONG KONG
Manufacturer Name:	SHENZHEN TECNO TECHNOLOGY CO.,LTD
Manufacturer Address:	1-4th Floor,3rd Building,Pacific Industrial Park,No.2088,Shenyan Road,Yantian District,Shenzhen,Guangdong,China

5 Test standard/s:

ANSI Std C95.1-2005	Safety Levels with Respect to Human Exposure to Radio Frequency Electromagnetic Fields, 3 kHz to 300 GHz.
IEEE Std 1528-2003	Recommended Practice for Determining the Peak Spatial-Average Specific Absorption Rate (SAR) in the Human Head from Wireless Communications Devices: Measurement Techniques
IEEE Std 1528a-2005	IEEE Recommended Practice for Determining the Peak Spatial-Average Specific Absorption Rate (SAR) in the Human Head from Wireless Communications Devices: Measurement Techniques Amendment 1: CAD File for Human Head Model (SAM Phantom)
RSS-102	Radio Frequency Exposure Compliance of Radiocommunication Apparatus (All Frequency Bands (Issue 4 of March 2010)
KDB447498 D01	General RF Exposure Guidance v05r02
KDB648474 D04	Handset SAR v01r02
KDB941225 D06	Hot Spot SAR V01r01
KDB248227 D01	SAR meas for 802.11 a/b/g v01r02
KDB865664 D01	SAR Measurement 100 MHz to 6 GHz v01r03
KDB865664 D02	RF Exposure Reporting v01r01
KDB 941225 D05	SAR for LTE Devices v02r05

5.1 RF exposure limits

Human Exposure	Uncontrolled Environment General Population	Controlled Environment Occupational
Spatial Peak SAR* (Brain/Body/Arms/Legs)	1.60 mW/g	8.00 mW/g
Spatial Average SAR** (Whole Body)	0.08 mW/g	0.40 mW/g
Spatial Peak SAR*** (Hands/Feet/Ankle/Wrist)	4.00 mW/g	20.00 mW/g

The limit applied in this test report is shown in bold letters

Notes:

- * The Spatial Peak value of the SAR averaged over any 1 gram of tissue (defined as a tissue volume in the shape of a cube) and over the appropriate averaging time.
- ** The Spatial Average value of the SAR averaged over the whole body.
- *** The Spatial Peak value of the SAR averaged over any 10 grams of tissue (defined as a tissue volume in the shape of a cube) and over the appropriate averaging time.

Uncontrolled Environments are defined as locations where there is the exposure of individuals who have no knowledge or control of their exposure.

Controlled Environments are defined as locations where there is exposure that may be incurred by persons who are aware of the potential for exposure, (i.e. as a result of employment or occupation).

5.2 SAR Definition

Specific Absorption Rate is defined as the time derivative (rate) of the incremental energy (dW) absorbed by (dissipated in) an incremental mass (dm) contained in a volume element (dV) of a given density (ρ).

$$SAR = \frac{d}{dt} \left(\frac{dW}{dm} \right) = \frac{d}{dt} \left(\frac{dW}{\rho dV} \right)$$

SAR is expressed in units of watts per kilogram (W/kg). SAR can be related to the electric field at a point by

$$SAR = \frac{\sigma |E|^2}{\rho}$$

where:

σ = conductivity of the tissue (S/m)

ρ = mass density of the tissue (kg/m³)

E = rms electric field strength (V/m)

6 SAR Measurement System

6.1 The Measurement System

Comosar is a system that is able to determine the SAR distribution inside a phantom of human being according to different standards. The Comosar system consists of the following items:

- Main computer to control all the system
- 6 axis robot
- Data acquisition system
- Miniature E-field probe
- Device holder
- Head simulating tissue

The following figure shows the system.



The EUT under test operating at the maximum power level is placed in the phone holder, under the phantom, which is filled with head simulating liquid. The E-Field probe measures the electric field inside the phantom. The OpenSAR software computes the results to give a SAR value in a 1g or 10g mass.

6.2 Robot

The COMOSAR system uses the high precision robots KR 6 R900 sixx type out of the newer series from Satimo SA (France). For the 6-axis controller COMOSAR system, the KUKA robot controller version from Satimo is used. The KR 6 R900 sixx robot series have many features that are important for

our application:

- High precision (repeatability 0.02 mm)
- High reliability (industrial design)
- Jerk-free straight movements
- Low ELF interference (the closed metallic construction shields against motor control fields)
- 6-axis controller

6.3 Probe

For the measurements the Specific Dosimetric E-Field Probe SSE 5 with following specifications is used

- Dynamic range: 0.01-100 W/kg
- Tip Diameter : 5 mm
- Distance between probe tip and sensor center: 2.5mm
- Distance between sensor center and the inner phantom surface: 4 mm
(repeatability better than +/- 1mm)
- Probe linearity: <0.25 dB
- Axial Isotropy: <0.25 dB
- Spherical Isotropy: <0.50 dB
- Calibration range: 300 to 2600MHz for head & body simulating liquid.

Angle between probe axis (evaluation axis) and surface normal line: less than 30°

6.4 Measurement procedure

The following steps are used for each test position

- Establish a call with the maximum output power with a base station simulator. The connection between the mobile and the base station simulator is established via air interface.
- Measurement of the local E-field value at a fixed location. This value serves as a reference value for calculating a possible power drift.
- Measurement of the SAR distribution with a grid of 8 to 16 mm * 8 to 16 mm and a constant distance to the inner surface of the phantom. Since the sensors can not directly measure at the inner phantom surface, the values between the sensors and the inner phantom surface are extrapolated. With these values the area of the maximum SAR is calculated by an interpolation scheme.
- Around this point, a cube of 30 * 30 * 30 mm or 32 * 32 * 32 mm is assessed by measuring 5 or 8 * 5 or 8 * 4 or 5 mm. With these data, the peak spatial-average SAR value can be calculated.

6.5 Description of interpolation/extrapolation scheme

- The local SAR inside the phantom is measured using small dipole sensing elements inside a probe body. The probe tip must not be in contact with the phantom surface in order to minimise measurements errors, but the highest local SAR will occur at the surface of the phantom.
- An extrapolation is used to determine these highest local SAR values. The extrapolation is based on a fourth-order least-square polynomial fit of measured data. The local SAR value is then extrapolated from the liquid surface with a 1 mm step.
- The measurements have to be performed over a limited time (due to the duration of the battery) so the step of measurement is high. It could vary between 5 and 8 mm. To obtain an accurate assessment of the maximum SAR average over 10 grams and 1 gram requires a very fine resolution in the three-dimensional scanned data array.

6.6 Phantom

For the measurements the Specific Anthropomorphic Mannequin (SAM) defined by the IEEE SCC-34/SC2 group is used. The phantom is a polyurethane shell integrated in a wooden table. The thickness of the phantom amounts to 2mm +/- 0.2mm. It enables the dosimetric evaluation of left and right phone usage and includes an additional flat phantom part for the simplified performance check. The phantom set-up includes a cover, which prevents the evaporation of the liquid.



System Material	Permittivity	Loss Tangent
Delrin	3.7	0.005

6.7 Device Holder

The positioning system allows obtaining cheek and tilting position with a very good accuracy. In compliance with CENELEC, the tilt angle uncertainty is lower than 1°.

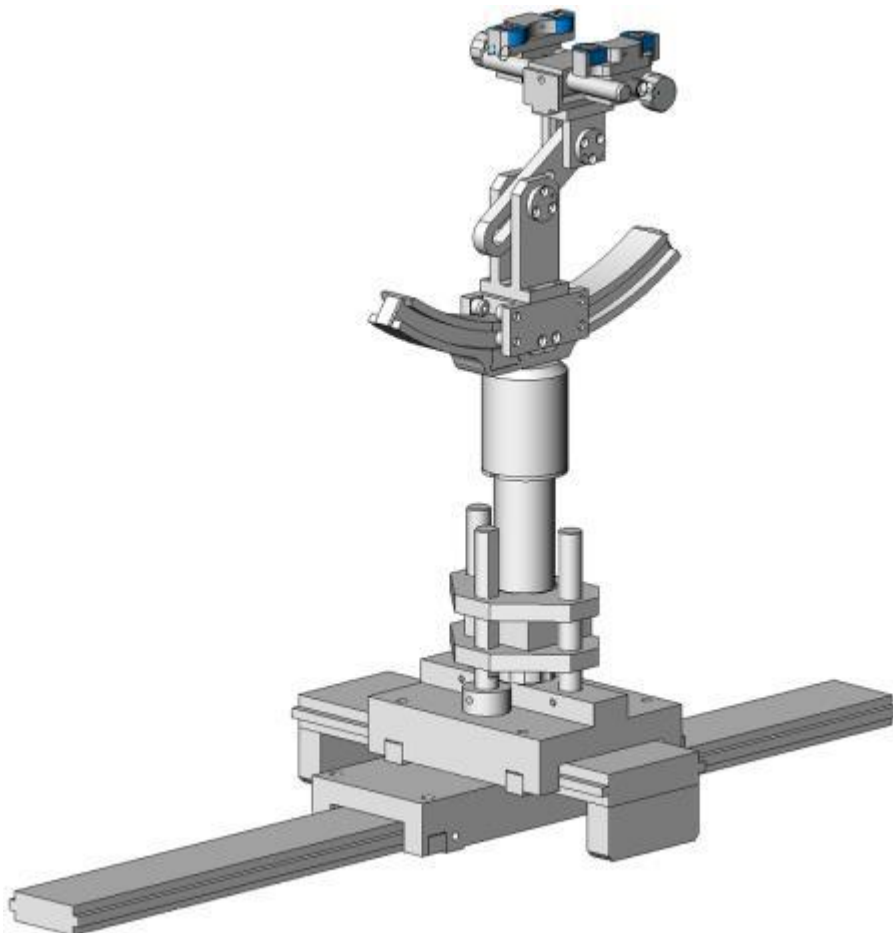

Device holder

System Material	Permittivity	Loss Tangent
Delrin	3.7	0.005

6.8 Video Positioning System

- The video positioning system is used in OpenSAR to check the probe. Which is composed of a camera, LED, mirror and mechanical parts. The camera is piloted by the main computer with firewire link.
- During the process, the actual position of the probe tip with respect to the robot arm is measured, as well as the probe length and the horizontal probe offset. The software then corrects all movements, such that the robot coordinates are valid for the probe tip.
- The repeatability of this process is better than 0.1 mm. If a position has been taught with an aligned probe, the same position will be reached with another aligned probe within 0.1 mm, even if the other probe has different dimensions. During probe rotations, the probe tip will keep its actual position.



6.9 Tissue simulating liquids: dielectric properties

The following materials are used for producing the tissue-equivalent materials.

(Liquids used for tests are marked with ☒):

Ingredients(% of weight)	Frequency (MHz)				
frequency band	<input type="checkbox"/> 450	<input checked="" type="checkbox"/> 835	<input checked="" type="checkbox"/> 1800	<input checked="" type="checkbox"/> 1900	<input checked="" type="checkbox"/> 2450
Tissue Type	Head	Head	Head	Head	Head
Water	38.56	41.45	52.64	55.242	62.7
Salt (NaCl)	3.95	1.45	0.36	0.306	0.5
Sugar	56.32	56.0	0.0	0.0	0.0
HEC	0.98	1.0	0.0	0.0	0.0
Bactericide	0.19	0.1	0.0	0.0	0.0
Triton X-100	0.0	0.0	0.0	0.0	36.8
DGBE	0.0	0.0	47.0	44.542	0.0
Ingredients(% of weight)	Frequency (MHz)				
frequency band	<input type="checkbox"/> 450	<input checked="" type="checkbox"/> 835	<input checked="" type="checkbox"/> 1800	<input checked="" type="checkbox"/> 1900	<input checked="" type="checkbox"/> 2450
Tissue Type	Body	Body	Body	Body	Body
Water	51.16	52.4	69.91	69.91	73.2
Salt (NaCl)	1.49	1.40	0.13	0.13	0.04
Sugar	46.78	45.0	0.0	0.0	0.0
HEC	0.52	1.0	0.0	0.0	0.0
Bactericide	0.05	0.1	0.0	0.0	0.0
Triton X-100	0.0	0.0	0.0	0.0	0.0
DGBE	0.0	0.0	29.96	29.96	26.7

Salt: 99+% Pure Sodium Chloride

Sugar: 98+% Pure Sucrose

Water: De-ionized, 16MΩ+ resistivity

HEC: Hydroxyethyl Cellulose

DGBE: 99+% Di(ethylene glycol) butyl ether, [2-(2-butoxyethoxy)ethanol]

Triton X-100(ultra pure): Polyethylene glycol mono [4-(1,1,3,3-tetramethylbutyl)phenyl]ether

6.10 Tissue simulating liquids: parameters

Tissue Type	Measured Frequency (MHz)	Target Tissue		Measured Tissue		Liquid Temp.	Test Date
		ϵ_r (+/-5%)	σ (S/m) (+/-5%)	ϵ_r	σ (S/m)		
835MHz Head	825	41.60 (39.52~43.68)	0.90 (0.86~0.95)	41.51	0.89	21.6°C	2016-6-17
	835	41.50 (39.43~43.58)	0.90 (0.86~0.95)	41.50	0.90		
	850	41.50 (39.43~43.58)	0.92 (0.87~0.97)	41.35	0.92		
835MHz Body	825	55.20 (52.44~57.96)	0.97 (0.92~1.02)	55.26	0.95	21.6°C	2016-6-17
	835	55.20 (52.44~57.96)	0.97 (0.92~1.02)	55.25	0.97		
	850	55.20 (52.44~57.96)	0.99 (0.94~1.04)	55.10	0.99		
1800MHz Head	1710	40.10 (38.10~42.10)	1.35 (1.28~1.42)	39.96	1.29	21.6°C	2016-6-18
	1730	40.10 (38.10~42.10)	1.35 (1.29~1.43)	40.58	1.34		
	1750	40.10 (38.10~42.10)	1.37 (1.30~1.44)	41.52	1.38		
	1800	40.00 (38.00~42.00)	1.40 (1.33~1.47)	40.08	1.45		
1800MHz Body	1710	53.50 (50.83~56.18)	1.46 (1.39~1.53)	53.26	1.50	21.6°C	2016-6-18
	1730	53.50 (50.83~56.18)	1.48 (1.41~1.55)	53.90	1.49		
	1750	53.40 (50.73~56.07)	1.49 (1.42~1.56)	54.79	1.49		
	1800	53.30 (50.64~55.97)	1.52 (1.44~1.60)	53.34	1.50		
1900MHz Head	1850	40.00 (38.00~42.00)	1.40 (1.33~1.47)	39.79	1.41	21.6°C	2016-6-22
	1880	40.00 (38.00~42.00)	1.40 (1.33~1.47)	40.09	1.39		
	1900	40.00 (38.00~42.00)	1.40 (1.33~1.47)	39.73	1.41		
	1910	40.00 (38.00~42.00)	1.40 (1.33~1.47)	39.40	1.43		
1900MHz Body	1850	53.30 (50.64~55.97)	1.52 (1.44~1.60)	53.22	1.52	21.6°C	2016-6-22
	1880	53.30 (50.64~55.97)	1.52 (1.44~1.60)	53.54	1.51		
	1900	53.30 (50.64~55.97)	1.52 (1.44~1.60)	53.15	1.53		
	1910	53.30 (50.64~55.97)	1.52 (1.44~1.60)	53.86	1.55		
2450MHz Head	2410	39.30 (37.34~41.26)	1.76 (1.67~1.85)	39.49	1.77	21.6°C	2016-6-20

	2435	39.20 (37.24~41.16)	1.79 (1.70~1.88)	39.32	1.79		
	2450	39.20 (37.24~41.16)	1.80 (1.71~1.89)	39.29	1.80		
	2460	39.20 (37.24~41.16)	1.81 (1.72~1.90)	39.29	1.81		
	2410	52.80 (50.16~55.44)	1.91 (1.81~2.00)	53.00	1.92		
2450MHz Body	2435	52.70 (50.07~55.34)	1.94 (1.84~2.04)	52.78	1.94	21.6°C	2016-6-20
	2450	52.70 (50.07~55.34)	1.95 (1.85~2.05)	52.74	1.95		
	2460	52.70 (50.07~55.34)	1.96 (1.86~2.06)	52.78	1.96		
	2410	52.80 (50.16~55.44)	1.91 (1.81~2.00)	53.00	1.92		
ϵ_r = Relative permittivity, σ = Conductivity							

7 System Check

7.1 System check procedure

The System check is performed by using a System check dipole which is positioned parallel to the planar part of the SAM phantom at the reference point. The distance of the dipole to the SAM phantom is determined by a spacer. The dipole is connected to the signal source consisting of signal generator and amplifier via a directional coupler, N-connector cable and adaption to SMA. It is fed with a power of 100 mW. To adjust this power a power meter is used. The power sensor is connected to the cable before the System check to measure the power at this point and do adjustments at the signal generator. At the outputs of the directional coupler both return loss as well as forward power are controlled during the validation to make sure that emitted power at the dipole is kept constant. This can also be checked by the power drift measurement after the test (result on plot).

System check results have to be equal or near the values determined during dipole calibration (target SAR in table above) with the relevant liquids and test system.

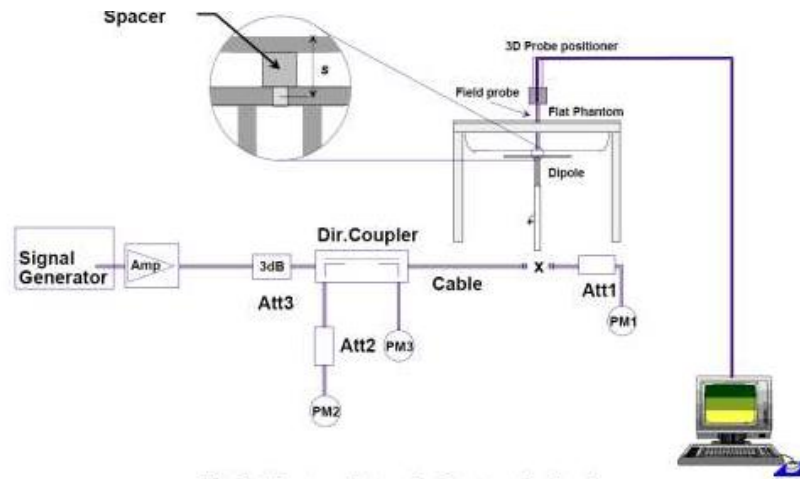

7.2 System check results

The system Check is performed for verifying the accuracy of the complete measurement system and performance of the software. The following table shows System check results for all frequency bands and tissue liquids used during the tests (plot(s) see annex A).

System Check	Target SAR (1W) (+/-10%)		Measured SAR (Normalized to 1W)		Liquid Temp.	Test Date
	1-g (mW/g)	10-g (mW/g)	1-g (mW/g)	10-g (mW/g)		
D835V2 Head	9.56 (8.60~10.52)	6.19 (5.57~6.81)	9.130	5.910	21.6°C	2016-6-17
D1800V2 Head	38.40 (34.56~42.24)	20.10 (18.09~22.11)	40.100	20.990	21.6°C	2016-6-18
D1900V2 Head	39.46 (35.51~43.41)	20.42 (18.38~22.46)	41.140	20.620	21.6°C	2016-6-22
D2450V2 Head	53.08 (47.77~58.39)	23.79 (21.41~26.17)	52.420	23.790	21.6°C	2016-6-20
D835V2 Body	9.86 (8.87~10.85)	6.38 (5.74~7.02)	9.610	6.230	21.6°C	2016-6-17
D1800V2 Body	40.06 (36.05~44.07)	20.76 (18.68~22.84)	41.780	22.040	21.6°C	2016-6-18
D1900V2 Body	40.06 (36.05~44.07)	20.76 (18.68~22.84)	42.790	21.450	21.6°C	2016-6-22
D2450V2 Body	54.76 (49.28~60.24)	24.47 (22.02~26.92)	56.440	25.760	21.6°C	2016-6-20

Note: All SAR values are normalized to 1W forward power.

8 SAR Test Test Configuration

8.1 GSM Test Configurations

SAR tests for GSM850 and GSM1900, a communication link is set up with a base station by air link. Using CMU200 the power lever is set to “5”and “0” in SAR of GSM850 and GSM1900. The tests in the band of GSM 850 and GSM 1900 are performed in the mode of GPRS/EGPRS function. Since the GPRS class is 12 for this EUT, it has at most 4 timeslots in uplink and at most 4 timeslots in downlink, the maximum total timeslot is 5.

8.2 Wi-Fi Test Configuration

For the 802.11b/g SAR tests, a communication link is set up with the test mode software for Wi-Fi mode test. The Absolute Radio Frequency Channel Number(ARFCN) is allocated to 1 ,6 and 11 respectively in the case of 2450 MHz.During the test,at the each test frequency channel, the EUT is operated at the RF continuous emission mode. Each channel should be tested at the lowest data rate. 802.11b/g operating modes are tested independently according to the service requirements in each frquency band. 802.11b/g modes are tested on channel 1, 6, 11; however,if output power reduction is necessary for channels 1 and/or 11 to meet restricted band requirements the highest output channel closest to each of these channels must be tested instead.

SAR is not required for 802.11g/n channels when the maximum average output power is less than 0.25dB higher than that measured on the corresponding 802.11b channels.

Mode	Band	GHz	Channel	“Default Test Channels”	
				802.11b	802.11g
802.11b/g	2.4 GHz	2412	1#	√	Δ
		2437	6	√	Δ
		2462	11#	√	Δ

Notes:

√ = “default test channels”

Δ= possible 802.11g channels with maximum average output ¼ dB the “default test channels”

= when output power is reduced for channel 1 and /or 11 to meet restricted band requirements the highest output channels closest to each of these channels should be tested.

802.11 Test Channels per FCC Requirements

9 Detailed Test Results

9.1 Conducted Power measurements

The output power was measured using an integrated RF connector and attached RF cable.

9.1.1 Conducted Power of GSM850

GSM850(SIM1)		Burst-Averaged output Power (dBm)			Division Factors	Source Based time Average Power(dBm)		
		128CH	190CH	251CH		128CH	190CH	251CH
GSM(CS)		33.25	33.36	33.30	-9.03	24.22	24.33	24.27
GPRS (GMSK)	1 Tx Slot	33.23	33.27	33.34	-9.03	24.20	24.24	24.31
	2 Tx Slots	32.21	32.38	32.41	-6.02	26.19	26.36	26.39
	3 Tx Slots	30.42	30.49	30.51	-4.26	26.16	26.23	26.25
	4 Tx Slots	29.66	29.46	29.68	-3.01	26.65	26.45	26.67
EGPRS (8-PSK)	1 Tx Slot	31.26	31.31	31.42	-9.03	22.23	22.28	22.39
	2 Tx Slots	30.18	30.33	30.37	-6.02	24.16	24.31	24.35
	3 Tx Slots	28.31	28.46	28.32	-4.26	24.05	24.2	24.06
	4 Tx Slots	27.7	27.58	27.56	-3.01	24.69	24.57	24.55

GSM850(SIM2)		Burst-Averaged output Power (dBm)			Division Factors	Source Based time Average Power(dBm)		
		128CH	190CH	251CH		128CH	190CH	251CH
GSM(CS)		33.20	33.37	33.38	-9.03	24.17	24.34	24.35
GPRS (GMSK)	1 Tx Slot	33.26	33.31	33.42	-9.03	24.23	24.28	24.39
	2 Tx Slots	32.18	32.33	32.37	-6.02	26.16	26.31	26.35
	3 Tx Slots	30.31	30.46	30.32	-4.26	26.05	26.20	26.06
	4 Tx Slots	29.70	29.58	29.56	-3.01	26.69	26.57	26.55
EGPRS (8-PSK)	1 Tx Slot	31.26	31.31	31.42	-9.03	22.23	22.28	22.39
	2 Tx Slots	30.18	30.33	30.37	-6.02	24.16	24.31	24.35
	3 Tx Slots	28.31	28.46	28.32	-4.26	24.05	24.2	24.06
	4 Tx Slots	27.7	27.58	27.56	-3.01	24.69	24.57	24.55

Note: 1) The conducted power of GSM850 is measured with RMS detector.

2) Source Based time Average Power was calculated from the measured burst-averaged output power by converting the slot powers into linear units and calculating the energy over 8 timeslots.

3) The bolded GPRS 4Tx slots mode was selected for SAR testing according to the highest Source Based time Average Power table.

4) channel /Frequency: 128/824.2; 190/836.6; 251/848.8

5) For Dual SIM Operation, when the power deviation of SIM1 and SIM2 is not more than 0.5dB, which tested SIM1 mode first, and then tested SIM2 mode at the worst position from SIM1 mode.

9.1.2 Conducted Power of GSM1900

GSM1900(SIM1)		Burst-Averaged output Power (dBm)			Division Factors	Source Based time Average Power(dBm)		
		512CH	661CH	810CH		512CH	661CH	810CH
GSM(CS)		30.56	30.51	30.31	-9.03	21.53	21.48	21.28
GPRS (GMSK)	1 Tx Slot	30.61	30.47	30.49	-9.03	21.58	21.44	21.46
	2 Tx Slots	29.39	29.38	29.27	-6.02	23.37	23.36	23.25
	3 Tx Slots	27.34	27.18	27.19	-4.26	23.08	22.92	22.93
	4 Tx Slots	26.49	26.59	26.43	-3.01	23.48	23.58	23.42
EGPRS (8-PSK)	1 Tx Slot	30.61	30.47	30.49	-9.03	21.58	21.44	21.46
	2 Tx Slots	29.39	29.38	29.27	-6.02	23.37	23.36	23.25
	3 Tx Slots	27.34	27.18	27.19	-4.26	23.08	22.92	22.93
	4 Tx Slots	26.49	26.59	26.43	-3.01	23.48	23.58	23.42

GSM1900(SIM2)		Burst-Averaged output Power (dBm)			Division Factors	Source Based time Average Power(dBm)		
		512CH	661CH	810CH		512CH	661CH	810CH
GSM(CS)		30.54	30.50	30.36	-9.03	21.51	21.47	21.33
GPRS (GMSK)	1 Tx Slot	30.67	30.47	30.50	-9.03	21.64	21.44	21.47
	2 Tx Slots	29.34	29.42	29.23	-6.02	23.32	23.40	23.21
	3 Tx Slots	27.33	27.24	27.24	-4.26	23.07	22.98	22.98
	4 Tx Slots	26.49	26.57	26.61	-3.01	23.48	23.56	23.60
EGPRS (8-PSK)	1 Tx Slot	30.61	30.47	30.49	-9.03	21.58	21.44	21.46
	2 Tx Slots	29.39	29.38	29.27	-6.02	23.37	23.36	23.25
	3 Tx Slots	27.34	27.18	27.19	-4.26	23.08	22.92	22.93
	4 Tx Slots	26.49	26.59	26.43	-3.01	23.48	23.58	23.42

Note: 1) The conducted power of GSM1900 is measured with RMS detector.

2) Source Based time Average Power was calculated from the measured burst-averaged output power by converting the slot powers into linear units and calculating the energy over 8 timeslots.

3)The bolded GPRS 4Tx slots mode was selected for SAR testing according the highest Source Based time Average Power table.

4) channel /Frequency: 512/1850.2; 661/1880; 810/1909.8

5) For Dual SIM Operation, when the power of deviation of SIM1 and SIM2 not more than 0.5dB, which tested SIM1 mode first,and then tested SIM2 mode at the worst position from SIM1 mode .

9.1.3 Conducted Power of UMTS Band II

UMTS Band I		Conducted Power (dBm)		
		9262CH	9400CH	9538CH
WCDMA	12.2kbps RMC	22.90	22.72	21.74
HSDPA	Subtest 1	21.90	22.71	21.73
	Subtest 2	20.91	20.87	19.96
	Subtest 3	21.24	20.58	20.16
	Subtest 4	20.89	20.46	20.76
HSUPA	Subtest 1	22.09	22.99	22.01
	Subtest 2	21.51	21.62	21.03
	Subtest 3	21.45	21.36	21.42
	Subtest 4	20.95	21.81	20.77
	Subtest 5	21.05	21.53	21.48

Note: 1) channel /Frequency: 9262/1852.4, 9400/1880, 9538/1907.6

9.1.4 Conducted Power of UMTS Band IV

UMTS Band I		Conducted Power (dBm)		
		1312CH	1413CH	1513CH
WCDMA	12.2kbps RMC	22.75	22.65	21.56
HSDPA	Subtest 1	21.80	22.47	21.60
	Subtest 2	20.73	20.83	19.83
	Subtest 3	21.07	20.45	20.05
	Subtest 4	20.81	20.43	20.75
HSUPA	Subtest 1	22.09	22.97	21.99
	Subtest 2	21.50	21.53	20.99
	Subtest 3	21.32	21.13	21.28
	Subtest 4	20.90	21.68	20.56
	Subtest 5	21.00	21.47	21.41

Note: 1) channel /Frequency: 1312/1712.4, 1413/1732.5, 1513/1752.6

9.1.5 Conducted Power of UMTS Band V

UMTS Band I		Conducted Power (dBm)		
		4132CH	4182CH	4233CH
WCDMA	12.2kbps RMC	22.89	22.57	21.59
HSDPA	Subtest 1	21.79	22.49	21.65
	Subtest 2	20.70	20.80	19.88
	Subtest 3	21.13	20.47	19.96
	Subtest 4	20.84	20.45	20.53
HSUPA	Subtest 1	21.98	22.82	21.89
	Subtest 2	21.31	21.48	20.87
	Subtest 3	21.24	21.17	21.39
	Subtest 4	20.76	21.72	20.77
	Subtest 5	20.91	21.47	21.34

Note: 1) channel /Frequency: 4132/826.4, 4182/836.4, 4233/846.6

9.1.6 Conducted Power of LET Band II

Conducted Power of LTE Band II						
Bandwidth	Modulation	RB size	RB offset	Channel	Channel	Channel
				18700	18900	19100
20MHz	QPSK	1	low	23.17	23.09	23.11
			middle	22.91	22.85	23.01
			high.	23.14	23.11	23.16
		50	low	22.23	22.09	22.38
			middle	22.24	22.12	22.42
			high.	22.18	22.21	22.50
		100	low	22.11	22.06	22.07

Note: 1) channel /Frequency: 18700/1860, 18900/1880,19100/1900.

9.1.7 Conducted Power of LET Band IV

Conducted Power of LTE Band IV						
Bandwidth	Modulation	RB size	RB offset	Channel	Channel	Channel
				20050	20175	20300
20MHz	QPSK	1	low	23.17	23.09	23.11
			middle	22.91	22.85	23.01
			high.	23.14	23.11	23.16
		50	low	22.23	22.09	22.38
			middle	22.24	22.12	22.42
			high.	22.18	22.21	22.50
		100	low	22.11	22.06	22.07

Note: 1) channel /Frequency: 20050/1720, 20175/1732.5, 20300/1745.

9.1.8 Conducted Power of LET Band VII

Conducted Power of LTE Band VII						
Bandwidth	Modulation	RB size	RB offset	Channel	Channel	Channel
				20850	21100	21350
20MHz	QPSK	1	low	23.17	23.09	23.11
			middle	22.91	22.85	23.01
			high.	23.14	23.11	23.16
		50	low	22.23	22.09	22.38
			middle	22.24	22.12	22.42
			high.	22.18	22.21	22.50
		100	low	22.11	22.06	22.07

Note: 1) channel /Frequency: 20850/2510, 21100/2535,21350/2560.

9.1.9 Conducted Power of LET Band XX

Conducted Power of LTE Band XX						
Bandwidth	Modulation	RB size	RB offset	Channel	Channel	Channel
				24225	24230	24245
15MHz	QPSK	1	low	23.17	23.09	23.11
			middle	22.91	22.85	23.01
			high.	23.14	23.11	23.16
		36	low	22.23	22.09	22.38
			middle	22.24	22.12	22.42
			high.	22.18	22.21	22.50
		75	low	22.11	22.06	22.07

Note: 1) channel /Frequency: 24225/839.5, 24230/840,24245/841.5.

9.1.10 Conducted Power of LET Band XXVIII

Conducted Power of LTE Band XXVIII						
Bandwidth	Modulation	RB size	RB offset	Channel	Channel	Channel
				27535	27540	27560
20MHz	QPSK	1	low	23.17	23.09	23.11
			middle	22.91	22.85	23.01
			high.	23.14	23.11	23.16
		50	low	22.23	22.09	22.38
			middle	22.24	22.12	22.42
			high.	22.18	22.21	22.50
		100	low	22.11	22.06	22.07

Note: 1) channel /Frequency: 27535/735.5, 27540/736,27560/738.

9.1.11 Conducted Power of Wi-Fi 2.4G

Wi-Fi 2450MHz	Channel	Average Power (dBm) for Data Rates (Mbps)							
		1	2	5.5	11	/	/	/	/
802.11b	1	14.15	14.21	14.19	14.09	/	/	/	/
	6	14.23	14.31	14.28	14.10	/	/	/	/
	11	14.25	14.34	14.32	14.11	/	/	/	/
802.11g	Channel	6	9	12	18	24	36	48	54
	1	12.86	12.81	12.85	12.91	12.87	12.96	12.89	12.92
	6	12.83	12.92	13.01	13.03	12.90	12.98	12.95	12.98
	11	13.01	13.09	13.07	13.11	13.10	13.09	12.99	13.13
802.11n (20M)	Channel	6.5	13	19.5	26	39	52	58.5	65
	1	12.95	13.04	13.05	13.10	12.98	13.08	13.10	12.99
	6	13.17	13.20	13.22	13.19	13.09	13.13	13.27	13.11
	11	13.19	13.22	13.30	13.24	13.10	13.26	13.26	13.30
802.11n (40M)	Channel	MCS0	MCS1	MCS2	MCS3	MCS4	MCS5	MCS6	MCS7
	3	12.36	12.39	12.40	12.46	12.51	12.48	12.51	12.49
	6	12.39	12.46	12.49	12.52	12.56	12.57	12.55	12.56
	9	12.55	12.59	12.62	12.68	12.69	12.62	12.62	12.67

Note:

1. The Average conducted power of Wi-Fi is measured with RMS detector.
2. Per KDB248227, For each frequency band, Testing at higher data rates and higher order modulations is not required when the maximum average output power for each of these configurations is less than 1/4dB higher than those measured at the lowest data rate.
- 3) channel /Frequency:1/2412,3/2422,6/2437,9/2452,11/2462,

9.1.12 Conducted Power of BT

The maximum output power of BT is:

BT	Average Conducted Power (dBm)		
	0CH	39CH	78CH
	5.72	5.59	5.43

Note: 1) channel /Frequency:0/2402,39/2441,78/2480.

9.2 SAR test results

Notes:

1) Per KDB447498 D01v05 r02, the SAR test shall be performed at the high, middle and low frequency channels of each operating mode. If the scaled SAR measured at mid-band channel for each test configuration is at least 3.0 dB lower than the SAR limit ($< 0.8 \text{ W/kg}$), testing at the high and low channels is optional.

2) Per KDB447498 D01v05r02, testing of other required channels within the operating mode of a frequency band is not required when the reported 1-g or 10-g SAR for the mid-band or highest output power channel is: $\leq 0.8 \text{ W/kg}$ or 2.0 W/kg , for 1-g or 10-g respectively, when the transmission band is $\leq 100 \text{ MHz}$. When the maximum output power variation across the required test channels is $> \frac{1}{2} \text{ dB}$, instead of the middle channel, the highest output power channel must be used.

3) Per KDB447498 D01v05r02, All measurement SAR result is scaled-up to account for tune-up tolerance is compliant.

4) Per KDB648474 D04v01r02, body-worn accessory testing is typically associated with voice operations. Therefore, GSM voice was evaluated for body-worn with headset SAR.

5) Per KDB248227 D01v01r02, the procedures required to establish specific device operating configurations for testing the SAR of 802.11 a/b/g transmitters.

6) Per KDB865664 D01v01r03, for each frequency band, repeated SAR measurement is required only when the measured SAR is $\geq 0.8 \text{ W/Kg}$; if the deviation among the repeated measurement is $\leq 20\%$, and the measured SAR $< 1.45 \text{ W/Kg}$, only one repeated measurement is required.

7) Per KDB865664 D02v01r01, SAR plot is only required for the highest measured SAR in each exposure configuration, wireless mode and frequency band combination; Plots are also required when the measured SAR is $> 1.5 \text{ W/kg}$, or $> 7.0 \text{ W/kg}$ for occupational exposure. The published RF exposure KDB procedures may require additional plots; for example, to support SAR to peak location separation ratio test exclusion and/or volume scan post-processing (Refer to appendix B for details).

8) Per KDB941225 D06v01r01, the DUT Dimension is bigger than $9 \text{ cm} \times 5 \text{ cm}$, so 10 mm is chosen as the test separation distance for Hotspot mode. When the antenna-to-edge distance is greater than 2.5 cm , such position does not need to be tested.

9.2.1 Results overview of GSM850

Test Position of Head	Test channel /Freq.(MHz)	Test Mode	SAR Value (W/kg)		Power Drift (%)	Conducted Power (dBm)	Tune-up Limit (dBm)	Scaled SAR _{1-g} (W/kg)	Liquid Temp.
			1-g	10-g					
Left Hand Touched	190/836.6	GSM	0.318	0.229	-4.060	31.940	32.000	0.322	21.6°C
Left Hand Tilted 15°	190/836.6	GSM	0.228	0.158	-3.860	31.940	32.000	0.231	21.6°C
Right Hand Touched	190/836.6	GSM	0.275	0.203	4.310	31.940	32.000	0.279	21.6°C
Right Hand Tilted 15°	190/836.6	GSM	0.180	0.122	1.130	31.940	32.000	0.183	21.6°C
Left Hand Touched	251/848.8	GSM	0.366	0.267	2.280	31.940	32.000	0.371	21.6°C
Left Hand Touched	128/824.2	GSM	0.242	0.179	4.370	31.940	32.000	0.245	21.6°C
Test the SIM2 Card Slot at the Worst Case Position of SIM1 Card Slot									
Left Hand Touched	251/848.8	GSM	0.407	0.296	4.880	31.940	32.000	0.413	21.6°C
Test Position of Body with 10mm	Test channel /Freq.(MHz)	Test Mode	SAR Value (W/kg)		Power Drift (%)	Conducted Power (dBm)	Tune-up Limit (dBm)	Scaled SAR _{1-g} (W/kg)	Liquid Temp.
			1-g	10-g					
Towards Phantom	190/836.6	GPRS 4TS	0.485	0.354	0.350	29.490	30.000	0.545	21.6°C
Towards Ground	190/836.6	GPRS 4TS	0.409	0.303	0.400	29.490	30.000	0.460	21.6°C
Towards Phantom	251/848.8	GPRS 4TS	0.560	0.414	3.980	29.490	30.000	0.630	21.6°C
Towards Phantom	128/824.2	GPRS 4TS	0.397	0.284	2.250	29.490	30.000	0.446	21.6°C
Towards Phantom	251/848.8	EDGE 4TS	0.092	0.065	-1.350	29.490	30.000	0.103	21.6°C
Towards Phantom with Headset	251/848.8	GSM	0.338	0.239	4.900	31.940	32.000	0.343	21.6°C
Test the SIM2 Card Slot at the Worst Case Position of SIM1 Card Slot									
Towards Phantom	251/848.8	GPRS 4TS	0.514	0.369	-2.020	29.490	30.000	0.578	21.6°C

9.2.2 Results overview of GSM1900

Test Position of Head	Test channel /Freq.(MHz)	Test Mode	SAR Value (W/kg)		Power Drift (%)	Conducted Power (dBm)	Tune-up Limit (dBm)	Scaled SAR _{1-g} (W/kg)	Liquid Temp.
			1-g	10-g					
Left Hand Touched	661/1880	GSM	0.084	0.035	0.000	29.410	30.000	0.096	21.6°C
Left Hand Tilted 15°	661/1880	GSM	0.032	0.013	0.000	29.410	30.000	0.037	21.6°C
Right Hand Touched	661/1880	GSM	0.065	0.029	0.000	29.410	30.000	0.074	21.6°C
Right Hand Tilted 15°	661/1880	GSM	0.006	0.001	1.030	29.410	30.000	0.007	21.6°C
Left Hand Touched	512/1850.2	GSM	0.091	0.041	0.000	29.410	30.000	0.104	21.6°C
Left Hand Touched	810/1909.8	GSM	0.160	0.080	0.000	29.410	30.000	0.183	21.6°C
Test the SIM2 Card Slot at the Worst Case Position of SIM1 Card Slot									
Left Hand Tilted 15°	810/1909.8	GSM	0.153	0.077	0.000	29.410	30.000	0.175	21.6°C
Test Position of Body with 10mm	Test channel /Freq.(MHz)	Test Mode	SAR Value (W/kg)		Power Drift (%)	Conducted Power (dBm)	Tune-up Limit (dBm)	Scaled SAR _{1-g} (W/kg)	Liquid Temp.
			1-g	10-g					
Towards Phantom	661/1880	GPRS 4TS	0.775	0.378	1.560	26.210	27.000	0.823	21.6°C
Towards Ground	661/1880	GPRS 4TS	0.851	0.407	-2.830	26.210	27.000	1.021	21.6°C
Towards Ground	512/1850.2	GPRS 4TS	0.940	0.432	-4.090	26.210	27.000	1.128	21.6°C
Towards Ground	810/1909.8	GPRS 4TS	0.976	0.482	-3.370	26.210	27.000	1.171	21.6°C
Towards Ground	810/1909.8	EDGE 4TS	0.275	0.119	-1.690	26.210	27.000	0.330	21.6°C
Towards Ground with Headset	810/1909.8	GSM	0.556	0.268	4.800	26.210	27.000	0.667	21.6°C
Test the SIM2 Card Slot at the Worst Case Position of SIM1 Card Slot									
Towards Ground	810/1909.8	GPRS 4TS	0.975	0.464	1.320	26.210	27.000	1.170	21.6°C

9.2.3 Results overview of Wi-Fi 2.4G

Test Position of Head	Test channel /Freq.(MHz)	Test Mode	SAR Value (W/kg)		Power Drift (%)	Conducted Power (dBm)	Tune-up Limit (dBm)	Scaled SAR _{1-g} (W/kg)	Liquid Temp.
			1-g	10-g					
Left Hand Touched	6/2437	802.11b	0.615	0.270	-1.160	1.6	9.890	12.000	21.6°C
Left Hand Tilted 15°	6/2437	802.11b	0.482	0.203	2.010	1.6	9.890	12.000	21.6°C
Right Hand Touched	6/2437	802.11b	0.344	0.144	-2.090	1.6	9.890	12.000	21.6°C
Right Hand Tilted 15°	6/2437	802.11b	0.306	0.124	-0.079	1.6	9.890	12.000	21.6°C
Left Hand Touched	1/2412	802.11b	0.876	0.400	-0.130	1.6	9.890	12.000	21.6°C
Left Hand Touched	11/2462	802.11b	0.698	0.307	4.530	1.6	9.890	12.000	21.6°C
Test Position of Hotspot with 10mm	Test channel /Freq.(MHz)	Test Mode	SAR Value (W/kg)		Power Drift (%)	Conducted Power (dBm)	Tune-up Limit (dBm)	Scaled SAR _{1-g} (W/kg)	Liquid Temp.
			1-g	10-g					
Towards Phantom	6/2437	802.11b	0.426	0.194	-0.290	1.6	9.890	12.000	21.6°C
Towards Ground	6/2437	802.11b	0.327	0.151	-1.760	1.6	9.890	12.000	21.6°C
Towards Phantom	1/2412	802.11b	0.273	0.112	-4.750	1.6	9.890	12.000	21.6°C
Towards Phantom	11/2462	802.11b	0.292	0.124	2.640	1.6	9.890	12.000	21.6°C

9.2.4 Results overview of UMTS Band II

Test Position of Head	Test channel /Freq.(MHz)	Test Mode	SAR Value (W/kg)		Power Drift (%)	Conducted Power (dBm)	Tune-up Limit (dBm)	Scaled SAR _{1-g} (W/kg)	Liquid Temp.
			1-g	10-g					
Left Hand Touched	9400/1880	RMC	0.192	0.111	0.070	22.630	23.000	0.209	21.6°C
Left Hand Tilted 15°	9400/1880	RMC	0.147	0.065	0.073	22.630	23.000	0.160	21.6°C
Right Hand Touched	9400/1880	RMC	0.160	0.080	0.079	22.630	23.000	0.174	21.6°C
Right Hand Tilted 15°	9400/1880	RMC	0.010	0.019	1.077	22.630	23.000	0.011	21.6°C
Left Hand Touched	9262/1852.4	RMC	0.099	0.075	0.048	22.630	23.000	0.108	21.6°C
Left Hand Touched	9538/1907.6	RMC	0.201	0.124	0.023	22.630	23.000	0.219	21.6°C
Test Position of Hotspot with 10mm	Test channel /Freq.(MHz)	Test Mode	SAR Value (W/kg)		Power Drift (%)	Conducted Power (dBm)	Tune-up Limit (dBm)	Scaled SAR _{1-g} (W/kg)	Liquid Temp.
			1-g	10-g					
Towards Phantom	9400/1880	RMC	0.720	0.255	1.391	22.630	23.000	0.784	21.6°C
Towards Ground	9400/1880	RMC	0.835	0.224	-3.008	22.630	23.000	0.909	21.6°C
Towards Ground	9262/1852.4	RMC	0.909	0.371	-4.173	22.630	23.000	0.989	21.6°C
Towards Ground	9538/1907.6	RMC	0.915	0.364	-3.397	22.630	23.000	0.996	21.6°C
Towards Ground with Headset	9538/1907.6	RMC	0.250	0.106	-1.872	22.630	23.000	0.272	21.6°C

9.2.5 Results overview of UMTS Band IV

Test Position of Head	Test channel /Freq.(MHz)	Test Mode	SAR Value (W/kg)		Power Drift (%)	Conducted Power (dBm)	Tune-up Limit (dBm)	Scaled SAR _{1-g} (W/kg)	Liquid Temp.
			1-g	10-g					
Left Hand Touched	1413/1732.5	RMC	0.149	0.196	1.894	22.730	23.000	0.158	21.6°C
Left Hand Tilted 15°	1413/1732.5	RMC	0.202	0.137	0.680	22.730	23.000	0.215	21.6°C
Right Hand Touched	1413/1732.5	RMC	0.167	0.118	2.676	22.730	23.000	0.178	21.6°C
Right Hand Tilted 15°	1413/1732.5	RMC	0.161	0.094	2.170	22.730	23.000	0.171	21.6°C
Left Hand Touched	1312/1712.4	RMC	0.189	0.201	1.453	22.730	23.000	0.201	21.6°C
Left Hand Touched	1513/1752.6	RMC	0.244	0.079	0.002	22.730	23.000	0.259	21.6°C
Test Position of Hotspot with 10mm	Test channel /Freq.(MHz)	Test Mode	SAR Value (W/kg)		Power Drift (%)	Conducted Power (dBm)	Tune-up Limit (dBm)	Scaled SAR _{1-g} (W/kg)	Liquid Temp.
			1-g	10-g					
Towards Phantom	1413/1732.5	RMC	0.289	0.201	0.109	22.730	23.000	0.307	21.6°C
Towards Ground	1413/1732.5	RMC	0.275	0.199	0.588	22.730	23.000	0.293	21.6°C
Towards Phantom	1312/1712.4	RMC	0.277	0.206	-0.291	22.730	23.000	0.295	21.6°C
Towards Phantom	1513/1752.6	RMC	0.277	0.199	0.417	22.730	23.000	0.295	21.6°C
Towards Phantom with Headset	1413/1732.5	RMC	0.242	0.177	0.258	22.730	23.000	0.258	21.6°C

9.2.6 Results overview of UMTS Band V

Test Position of Head	Test channel /Freq.(MHz)	Test Mode	SAR Value (W/kg)		Power Drift (%)	Conducted Power (dBm)	Tune-up Limit (dBm)	Scaled SAR _{1-g} (W/kg)	Liquid Temp.
			1-g	10-g					
Left Hand Touched	4182/836.4	RMC	0.275	0.207	1.900	22.730	23.000	0.293	21.6°C
Left Hand Tilted 15°	4182/836.4	RMC	0.229	0.167	0.730	22.730	23.000	0.244	21.6°C
Right Hand Touched	4182/836.4	RMC	0.261	0.197	2.820	22.730	23.000	0.278	21.6°C
Right Hand Tilted 15°	4182/836.4	RMC	0.175	0.129	2.190	22.730	23.000	0.186	21.6°C
Left Hand Touched	4233/846.6	RMC	0.290	0.218	1.580	22.730	23.000	0.309	21.6°C
Left Hand Touched	4132/826.4	RMC	0.252	0.191	0.080	22.730	23.000	0.268	21.6°C
Test Position of Hotspot with 10mm	Test channel /Freq.(MHz)	Test Mode	SAR Value (W/kg)		Power Drift (%)	Conducted Power (dBm)	Tune-up Limit (dBm)	Scaled SAR _{1-g} (W/kg)	Liquid Temp.
			1-g	10-g					
Towards Phantom	4182/836.4	RMC	0.295	0.214	0.110	22.730	23.000	0.314	21.6°C
Towards Ground	4182/836.4	RMC	0.279	0.204	0.600	22.730	23.000	0.297	21.6°C
Towards Phantom	4132/826.4	RMC	0.290	0.211	-0.280	22.730	23.000	0.309	21.6°C
Towards Phantom	4233/846.6	RMC	0.290	0.210	0.430	22.730	23.000	0.309	21.6°C
Towards Phantom with Headset	4182/836.4	RMC	0.244	0.177	0.260	22.730	23.000	0.260	21.6°C

9.2.7 Results overview of LTE Band II

Test Position of Head	Test channel /Freq.(MHz)	Test Mode	SAR Value (W/kg)		Power Drift (%)	Conducted Power (dBm)	Tune-up Limit (dBm)	Scaled SAR _{1-g} (W/kg)	Liquid Temp.
			1-g	10-g					
Left Hand Touched	19100/1900	20M QPSK 1RB#99	0.093	0.024	1.467	22.730	23.000	0.099	21.6°C
Left Hand Tilted 15°	19100/1900	20M QPSK 1RB#99	0.081	0.012	-1.766	22.730	23.000	0.086	21.6°C
Right Hand Touched	19100/1900	20M QPSK 1RB#99	0.092	0.047	4.418	22.730	23.000	0.098	21.6°C
Right Hand Tilted 15°	19100/1900	20M QPSK 1RB#99	0.051	0.022	0.579	22.730	23.000	0.055	21.6°C
Left Hand Touched	19100/1900	20M QPSK 50RB#50	0.066	0.016	-4.727	22.730	23.000	0.071	21.6°C
Left Hand Touched	19100/1900	20M QPSK 100RB#0	0.063	0.032	-4.345	22.730	23.000	0.067	21.6°C
Left Hand Touched	18700/1860	20M QPSK 1RB#99	0.075	0.044	0.175	22.730	23.000	0.079	21.6°C
Left Hand Touched	18900/1880	20M QPSK 1RB#99	0.091	0.056	-3.632	22.730	23.000	0.097	21.6°C
Test Position of Hotspot with 10mm	Test channel /Freq.(MHz)	Test Mode	SAR Value (W/kg)		Power Drift (%)	Conducted Power (dBm)	Tune-up Limit (dBm)	Scaled SAR _{1-g} (W/kg)	Liquid Temp.
			1-g	10-g					
Towards Phantom	19100/1900	20M QPSK 1RB#99	0.703	0.375	2.711	22.730	23.000	0.748	21.6°C
Towards Ground	19100/1900	20M QPSK 1RB#99	0.979	0.529	-0.504	22.730	23.000	1.042	21.6°C
Towards Ground	19100/1900	20M QPSK 50RB#50	0.797	0.399	-1.667	22.730	23.000	0.848	21.6°C
Towards Ground	19100/1900	20M QPSK 100RB#0	0.819	0.434	-0.070	22.730	23.000	0.871	21.6°C
Towards Ground	18700/1860	20M QPSK 1RB#99	0.908	0.585	-0.460	22.730	23.000	0.967	21.6°C
Towards Ground	18900/1880	20M QPSK 1RB#99	0.960	0.522	-0.376	22.730	23.000	1.022	21.6°C

9.2.8 Results overview of LTE Band IV

Test Position of Head	Test channel /Freq.(MHz)	Test Mode	SAR Value (W/kg)		Power Drift (%)	Conducted Power (dBm)	Tune-up Limit (dBm)	Scaled SAR _{1-g} (W/kg)	Liquid Temp.
			1-g	10-g					
Left Hand Touched	20050/1720	20M QPSK 1RB#99	0.095	0.048	1.470	22.730	23.000	0.101	21.6°C
Left Hand Tilted 15°	20050/1720	20M QPSK 1RB#99	0.087	0.039	-1.760	22.730	23.000	0.093	21.6°C
Right Hand Touched	20050/1720	20M QPSK 1RB#99	0.095	0.053	4.440	22.730	23.000	0.101	21.6°C
Right Hand Tilted 15°	20050/1720	20M QPSK 1RB#99	0.067	0.030	0.580	22.730	23.000	0.071	21.6°C
Left Hand Touched	20175/1732 .5	20M QPSK 50RB#25	0.074	0.036	-4.720	22.730	23.000	0.079	21.6°C
Left Hand Touched	20175/1732 .5	20M QPSK 100RB#0	0.073	0.036	-4.320	22.730	23.000	0.078	21.6°C
Left Hand Touched	20175/1732 .5	20M QPSK 1RB#50	0.087	0.044	0.200	22.730	23.000	0.093	21.6°C
Left Hand Touched	20300/1745	20M QPSK 1RB#50	0.113	0.059	-3.630	22.730	23.000	0.120	21.6°C
Test Position of Hotspot with 10mm	Test channel /Freq.(MHz)	Test Mode	SAR Value (W/kg)		Power Drift (%)	Conducted Power (dBm)	Tune-up Limit (dBm)	Scaled SAR _{1-g} (W/kg)	Liquid Temp.
			1-g	10-g					
Towards Phantom	20050/1720	20M QPSK 1RB#99	0.733	0.400	2.740	22.730	23.000	0.780	21.6°C
Towards Ground	20050/1720	20M QPSK 1RB#99	0.950	0.535	-0.500	22.730	23.000	1.011	21.6°C
Towards Ground	20175/1732 .5	20M QPSK 50RB#25	0.807	0.425	-1.640	22.730	23.000	0.859	21.6°C
Towards Ground	20175/1732 .5	20M QPSK 100RB#0	0.823	0.439	-0.040	22.730	23.000	0.876	21.6°C
Towards Ground	20175/1732 .5	20M QPSK 1RB#50	0.901	0.593	-0.430	22.730	23.000	0.959	21.6°C
Towards Ground	20300/1745	20M QPSK 1RB#50	0.941	0.534	-0.350	22.730	23.000	1.001	21.6°C

9.2.9 Results overview of LTE Band VII

Test Position of Head	Test channel /Freq.(MHz)	Test Mode	SAR Value (W/kg)		Power Drift (%)	Conducted Power (dBm)	Tune-up Limit (dBm)	Scaled SAR _{1-g} (W/kg)	Liquid Temp.
			1-g	10-g					
Left Hand Touched	20850/2510	20M QPSK 1RB#50	0.071	0.030	1.449	22.730	23.000	0.076	21.6°C
Left Hand Tilted 15°	20850/2510	20M QPSK 1RB#50	0.057	0.014	-1.793	22.730	23.000	0.060	21.6°C
Right Hand Touched	20850/2510	20M QPSK 1RB#50	0.062	0.027	4.412	22.730	23.000	0.066	21.6°C
Right Hand Tilted 15°	20850/2510	20M QPSK 1RB#50	0.055	-0.008	0.554	22.730	23.000	0.058	21.6°C
Left Hand Touched	20850/2510	20M QPSK 50RB#50	0.048	0.006	-4.742	22.730	23.000	0.051	21.6°C
Left Hand Touched	20850/2510	20M QPSK 100RB#0	0.030	0.007	-4.358	22.730	23.000	0.032	21.6°C
Left Hand Touched	21100/2535	20M QPSK 1RB#50	0.055	0.027	0.169	22.730	23.000	0.059	21.6°C
Left Hand Touched	21350/2560	20M QPSK 1RB#50	0.091	0.024	-3.663	22.730	23.000	0.097	21.6°C
Test Position of Hotspot with 10mm	Test channel /Freq.(MHz)	Test Mode	SAR Value (W/kg)		Power Drift (%)	Conducted Power (dBm)	Tune-up Limit (dBm)	Scaled SAR _{1-g} (W/kg)	Liquid Temp.
			1-g	10-g					
Towards Phantom	20850/2510	20M QPSK 1RB#50	0.729	0.373	2.716	22.730	23.000	0.776	21.6°C
Towards Ground	20850/2510	20M QPSK 1RB#50	0.879	0.518	-0.528	22.730	23.000	0.936	21.6°C
Towards Ground	20850/2510	20M QPSK 50RB#50	0.783	0.415	-1.653	22.730	23.000	0.833	21.6°C
Towards Ground	20850/2510	20M QPSK 100RB#0	0.802	0.418	-0.065	22.730	23.000	0.853	21.6°C
Towards Ground	21100/2535	20M QPSK 1RB#50	0.881	0.574	-0.451	22.730	23.000	0.938	21.6°C
Towards Ground	21350/2560	20M QPSK 1RB#50	0.825	0.508	-0.366	22.730	23.000	0.878	21.6°C

9.2.10 Results overview of LTE Band XX

Test Position of Head	Test channel /Freq.(MHz)	Test Mode	SAR Value (W/kg)		Power Drift (%)	Conducted Power (dBm)	Tune-up Limit (dBm)	Scaled SAR _{1-g} (W/kg)	Liquid Temp.
			1-g	10-g					
Left Hand Touched	24225/839.5	15M QPSK 1RB#0	0.054	0.012	1.432	22.730	23.000	0.058	21.6°C
Left Hand Tilted 15°	24225/839.5	15M QPSK 1RB#0	0.051	0.008	-1.810	22.730	23.000	0.055	21.6°C
Right Hand Touched	24225/839.5	15M QPSK 1RB#0	0.060	0.014	4.397	22.730	23.000	0.064	21.6°C
Right Hand Tilted 15°	24225/839.5	15M QPSK 1RB#0	0.036	-0.012	0.544	22.730	23.000	0.038	21.6°C
Left Hand Touched	24225/839.5	15M QPSK 36RB#0	0.036	0.004	-4.752	22.730	23.000	0.038	21.6°C
Left Hand Touched	24225/839.5	15M QPSK 75RB#0	0.006	0.006	-4.373	22.730	23.000	0.006	21.6°C
Left Hand Touched	24230/840	15M QPSK 1RB#0	0.055	0.010	0.151	22.730	23.000	0.059	21.6°C
Left Hand Touched	24245/841.5	15M QPSK 1RB#0	0.075	0.017	-3.664	22.730	23.000	0.080	21.6°C
Test Position of Hotspot with 10mm	Test channel /Freq.(MHz)	Test Mode	SAR Value (W/kg)		Power Drift (%)	Conducted Power (dBm)	Tune-up Limit (dBm)	Scaled SAR _{1-g} (W/kg)	Liquid Temp.
			1-g	10-g					
Towards Phantom	24225/839.5	15M QPSK 1RB#0	0.724	0.356	2.701	22.730	23.000	0.771	21.6°C
Towards Ground	24225/839.5	15M QPSK 1RB#0	0.508	0.513	-0.537	22.730	23.000	0.541	21.6°C
Towards Ground	24225/839.5	15M QPSK 36RB#0	0.768	0.402	-1.667	22.730	23.000	0.817	21.6°C
Towards Ground	24225/839.5	15M QPSK 75RB#0	0.789	0.403	-0.075	22.730	23.000	0.839	21.6°C
Towards Ground	24230/840	15M QPSK 1RB#0	0.808	0.558	-0.470	22.730	23.000	0.860	21.6°C
Towards Ground	24245/841.5	15M QPSK 1RB#0	0.748	0.495	-0.375	22.730	23.000	0.796	21.6°C

9.2.11 Results overview of LTE Band XXVIII

Test Position of Head	Test channel /Freq.(MHz)	Test Mode	SAR Value (W/kg)		Power Drift (%)	Conducted Power (dBm)	Tune-up Limit (dBm)	Scaled SAR _{1-g} (W/kg)	Liquid Temp.
			1-g	10-g					
Left Hand Touched	27540/736	20M QPSK 1RB#50	0.091	0.041	1.470	22.730	23.000	0.097	21.6°C
Left Hand Tilted 15°	27540/736	20M QPSK 1RB#50	0.081	0.031	-2.560	22.730	23.000	0.086	21.6°C
Right Hand Touched	27540/736	20M QPSK 1RB#50	0.092	0.044	4.300	22.730	23.000	0.098	21.6°C
Right Hand Tilted 15°	27540/736	20M QPSK 1RB#50	0.065	0.029	0.580	22.730	23.000	0.069	21.6°C
Left Hand Touched	27540/736	20M QPSK 50RB#25	0.070	0.030	-3.230	22.730	23.000	0.074	21.6°C
Left Hand Touched	27540/736	20M QPSK 100RB#0	0.069	0.036	-4.320	22.730	23.000	0.074	21.6°C
Left Hand Touched	27535/735.5	20M QPSK 1RB#50	0.085	0.037	0.200	22.730	23.000	0.090	21.6°C
Left Hand Touched	27560/738	20M QPSK 1RB#50	0.112	0.058	-3.630	22.730	23.000	0.119	21.6°C
Test Position of Hotspot with 10mm	Test channel /Freq.(MHz)	Test Mode	SAR Value (W/kg)		Power Drift (%)	Conducted Power (dBm)	Tune-up Limit (dBm)	Scaled SAR _{1-g} (W/kg)	Liquid Temp.
			1-g	10-g					
Towards Phantom	27540/736	20M QPSK 1RB#50	0.729	0.386	2.740	22.730	23.000	0.775	21.6°C
Towards Ground	27540/736	20M QPSK 1RB#50	0.870	0.533	-0.300	22.730	23.000	0.926	21.6°C
Towards Ground	27540/736	20M QPSK 50RB#25	0.796	0.410	-1.550	22.730	23.000	0.847	21.6°C
Towards Ground	27540/736	20M QPSK 100RB#0	0.811	0.433	-0.040	22.730	23.000	0.863	21.6°C
Towards Ground	27535/735.5	20M QPSK 1RB#50	0.929	0.584	-0.430	22.730	23.000	0.988	21.6°C
Towards Ground	27560/738	20M QPSK 1RB#50	0.902	0.522	-0.420	22.730	23.000	0.960	21.6°C

10 Multiple Transmitter Information

The SAR measurement positions of each side are as below:

Mode	Front Side	Rear Side	Left Side	Right Side	Top Side	Bottom Side
2G/3G/4G Antenna	Yes	Yes	No	No	No	No
Wi-Fi	Yes	Yes	No	No	No	No

1) Per KDB941225 D06v01r01, the DUT Dimension is bigger than 9 cm x 5 cm, so 10mm is chosen as the test separation distance for Hotspot mode. When the antenna-to-edge distance is greater than 2.5cm, such position does not need to be tested.

10.1.1 Stand-alone SAR test exclusion

The 1-g and 10-g SAR test exclusion thresholds for 100 MHz to 6 GHz at test separation distances \leq 50 mm are determined by:

$[(\text{max. power of channel, including tune-up tolerance, mW}) / (\text{min. test separation distance, mm})] \cdot [\sqrt{f(\text{GHz})}] \leq 3.0$ for 1-g SAR and ≤ 7.5 for 10-g extremity SAR, where

- $f(\text{GHz})$ is the RF channel transmit frequency in GHz
- Power and distance are rounded to the nearest mW and mm before calculation
- The result is rounded to one decimal place for comparison

When the minimum test separation distance is < 5 mm, a distance of 5 mm is applied to determine SAR test exclusion.

a) Head position

Mode	Pmax(dBm)	Pmax(mW)	Distance(mm)	f(GHz)	Calculation Result	exclusion Threshold	SAR test exclusion
BT	4.5	2.82	5.00	2.450	0.88	3.00	Yes

b) Body-Worn position

Mode	Pmax(dBm)	Pmax(mW)	Distance(mm)	f(GHz)	Calculation Result	exclusion Threshold	SAR test exclusion
BT	4.5	2.82	10.00	2.450	0.44	3.00	Yes

When the standalone SAR test exclusion applies to an antenna that transmits simultaneously with other antennas, the standalone SAR must be estimated according to the following to determine simultaneous transmission SAR test exclusion

$(\text{max. power of channel, including tune-up tolerance, mW}) / (\text{min. test separation distance, mm}) \cdot [\sqrt{f(\text{GHz})} / x]$ W/kg for test separation distances ≤ 50 mm, where $x = 7.5$ for 1-g SAR.

When the minimum test separation distance is < 5 mm, a distance of 5 mm is applied to determine SAR test exclusion.

Mode	Position	Pmax(dBm)	Pmax(mW)	Distance(mm)	f(GHz)	X	Estimated SAR(W/Kg)
BT	Head	4.50	2.82	5.00	2.45	7.50	0.117
BT	Body	4.50	2.82	10.00	2.45	7.50	0.059

10.1.2 Simultaneous Transmission Possibilities

The Simultaneous Transmission Possibilities are as below:

Simultaneous Transmission Possibilities			
Simultaneous Tx Combination	Configuration	Head	Body
1	GSM/GPRS/UMTS/LTE+Wi-Fi	YES	YES
2	GSM/GPRS/UMTS/LTE+BT	YES	YES

Note: The device does not support simultaneous BT and Wi-Fi ,because the BT and Wi-Fi share the same antenna and can't transmit simultaneously.

10.1.3 SAR Summation Scenario

Test Position		Scaled SAR _{Max}		\sum_{1-g} SAR	SPLSP
		GSM850	Wi-Fi		
Head	Left Hand Touched	0.322	1.000	1.322	NA
	Left Hand Tilted 15°	0.231	0.784	1.015	NA
	Right Hand Touched	0.279	0.559	0.838	NA
	Right Hand Tilted 15°	0.183	0.497	0.68	NA
Body	Towards Phantom	0.545	0.692	1.237	NA
	Towards Ground	0.460	0.532	0.992	NA
	Towards Phantom with headset	0.343	0.692	1.035	NA
	Towards Ground with headset	/	/	/	NA

Note: Simultaneous Tx Combination of GSM850 and Wi-Fi

Test Position		Scaled SAR _{Max}		\sum_{1-g} SAR	SPLSP
		GSM1900	Wi-Fi		
Head	Left Hand Touched	0.098	1.000	1.098	NA
	Left Hand Tilted 15°	0.037	0.784	0.821	NA
	Right Hand Touched	0.074	0.559	0.633	NA
	Right Hand Tilted 15°	0.007	0.497	0.504	NA
Body	Towards Phantom	0.823	0.692	1.515	NA
	Towards Ground	0.021	0.532	0.553	NA
	Towards Phantom with headset	/	/	/	NA
	Towards Ground with headset	0.667	0.532	1.199	NA

Note: Simultaneous Tx Combination of GSM1900 and Wi-Fi

Test Position		Scaled SAR _{Max}		\sum_{1-g} SAR	SPLSP
		UMTS Band II	Wi-Fi		
Head	Left Hand Touched	0.209	1.000	1.209	NA
	Left Hand Tilted 15°	0.160	0.784	0.944	NA
	Right Hand Touched	0.174	0.559	0.733	NA
	Right Hand Tilted 15°	0.011	0.497	0.508	NA
Body	Towards Phantom	0.784	0.692	1.476	NA
	Towards Ground	0.909	0.532	1.441	NA
	Towards Phantom with headset	/	/	/	NA
	Towards Ground with headset	0.272	0.532	0.804	NA

Note: Simultaneous Tx Combination of UMTS Band II and Wi-Fi

Test Position		Scaled SAR _{Max}		\sum_{1-g} SAR	SPLSP
		UMTS Band IV	Wi-Fi		
Head	Left Hand Touched	0.158	1.000	1.158	NA
	Left Hand Tilted 15°	0.215	0.784	0.999	NA
	Right Hand Touched	0.178	0.559	0.737	NA
	Right Hand Tilted 15°	0.171	0.497	0.668	NA
Body	Towards Phantom	0.307	0.692	0.999	NA
	Towards Ground	0.293	0.532	0.825	NA
	Towards Phantom with headset	0.258	0.692	0.950	NA
	Towards Ground with headset	/			NA

Note: Simultaneous Tx Combination of UMTS Band IV and Wi-Fi

Test Position		Scaled SAR _{Max}		\sum_{1-g} SAR	SPLSP
		UMTS Band V	Wi-Fi		
Head	Left Hand Touched	0.293	1.000	1.293	NA
	Left Hand Tilted 15°	0.244	0.784	1.028	NA
	Right Hand Touched	0.278	0.559	0.837	NA
	Right Hand Tilted 15°	0.188	0.497	0.685	NA
Body	Towards Phantom	0.314	0.692	1.006	NA
	Towards Ground	0.297	0.532	0.829	NA
	Towards Phantom with headset	0.260	0.692	0.952	NA
	Towards Ground with headset	/	/	/	NA

Note: Simultaneous Tx Combination of UMTS Band V and Wi-Fi

Test Position		Scaled SAR _{Max}		\sum_{1-g} SAR	SPLSP
		LTE Band II	Wi-Fi		
Head	Left Hand Touched	0.099	1.000	1.099	NA
	Left Hand Tilted 15°	0.086	0.784	0.870	NA
	Right Hand Touched	0.098	0.559	0.657	NA
	Right Hand Tilted 15°	0.055	0.497	0.552	NA
Body	Towards Phantom	0.748	0.692	1.440	NA
	Towards Ground	1.042	0.532	1.574	NA
	Towards Phantom with headset	/	/	/	NA
	Towards Ground with headset	/	/	/	NA

Note: Simultaneous Tx Combination of LTE Band II and Wi-Fi

Test Position		Scaled SAR _{Max}		\sum_{1-g} SAR	SPLSP
		LTE Band IV	Wi-Fi		
Head	Left Hand Touched	0.101	1.000	1.101	NA
	Left Hand Tilted 15°	0.093	0.784	0.877	NA
	Right Hand Touched	0.101	0.559	0.66	NA
	Right Hand Tilted 15°	0.071	0.497	0.568	NA
Body	Towards Phantom	0.780	0.692	1.472	NA
	Towards Ground	1.011	0.532	1.543	NA
	Towards Phantom with headset	/	/	/	NA
	Towards Ground with headset	/	/	/	NA

Note: Simultaneous Tx Combination of LTE Band IV and Wi-Fi

Test Position		Scaled SAR _{Max}		\sum_{1-g} SAR	SPLSP
		LTE Band VII	Wi-Fi		
Head	Left Hand Touched	0.076	1.000	1.076	NA
	Left Hand Tilted 15°	0.060	0.784	0.844	NA
	Right Hand Touched	0.066	0.559	0.625	NA
	Right Hand Tilted 15°	0.058	0.497	0.555	NA
Body	Towards Phantom	0.776	0.692	1.468	NA
	Towards Ground	0.938	0.532	1.470	NA
	Towards Phantom with headset	/	/	/	NA
	Towards Ground with headset	/	/	/	NA

Note: Simultaneous Tx Combination of LTE Band VII and Wi-Fi

Test Position		Scaled SAR _{Max}		\sum_{1-g} SAR	SPLSP
		LTE Band XX	Wi-Fi		
Head	Left Hand Touched	0.058	1.000	1.058	NA
	Left Hand Tilted 15°	0.055	0.784	0.839	NA
	Right Hand Touched	0.064	0.559	0.623	NA
	Right Hand Tilted 15°	0.038	0.497	0.535	NA
Body	Towards Phantom	0.771	0.692	1.463	NA
	Towards Ground	0.541	0.532	1.073	NA
	Towards Phantom with headset	/	/	/	NA
	Towards Ground with headset	/	/	/	NA

Note: Simultaneous Tx Combination of LTE Band XX and Wi-Fi

Test Position		Scaled SAR _{Max}		\sum_{1-g} SAR	SPLSP
		LTE Band XXVIII	Wi-Fi		
Head	Left Hand Touched	0.097	1.000	1.097	NA
	Left Hand Tilted 15°	0.086	0.784	0.870	NA
	Right Hand Touched	0.098	0.559	0.657	NA
	Right Hand Tilted 15°	0.069	0.497	0.566	NA
Body	Towards Phantom	0.775	0.692	1.467	NA
	Towards Ground	0.926	0.532	1.458	NA
	Towards Phantom with headset	/	/	/	NA
	Towards Ground with headset	/	/	/	NA

Note: Simultaneous Tx Combination of LTE Band XXVIII and Wi-Fi

MAX. \sum SAR_{1g} = 1.28W/kg < 1.6 W/kg, so the Simultaneous SAR is not required for Wi-Fi and GSM&UMTS<E antenna.

Test Position		Scaled SAR _{Max}		\sum_{1-g} SAR	SPLSP
		GSM850	BT		
Head	Left Hand Touched	0.322	0.117	0.439	NA
	Left Hand Tilted 15°	0.231	0.117	0.348	NA
	Right Hand Touched	0.279	0.117	0.396	NA
	Right Hand Tilted 15°	0.183	0.117	0.300	NA
Body	Towards Phantom	0.545	0.059	0.604	NA
	Towards Ground	0.46	0.059	0.519	NA
	Towards Phantom with headset	0.343	0.059	0.402	NA
	Towards Ground with headset	/	/	/	NA

Note: Simultaneous Tx Combination of GSM850 and BT

Test Position		Scaled SAR _{Max}		\sum_{1-g} SAR	SPLSP
		GSM1900	BT		
Head	Left Hand Touched	0.098	0.117	0.215	NA
	Left Hand Tilted 15°	0.037	0.117	0.154	NA
	Right Hand Touched	0.074	0.117	0.191	NA
	Right Hand Tilted 15°	0.007	0.117	0.124	NA
Body	Towards Phantom	0.823	0.059	0.882	NA
	Towards Ground	0.021	0.059	0.080	NA
	Towards Phantom with headset	/	/	/	NA
	Towards Ground with headset	0.667	0.059	0.726	NA

Note: Simultaneous Tx Combination of GSM1900 and BT

Test Position		Scaled SAR _{Max}		\sum_{1-g} SAR	SPLSP
		UMTS Band II	BT		
Head	Left Hand Touched	0.209	0.117	0.326	NA
	Left Hand Tilted 15°	0.16	0.117	0.277	NA
	Right Hand Touched	0.174	0.117	0.291	NA
	Right Hand Tilted 15°	0.011	0.117	0.128	NA
Body	Towards Phantom	0.784	0.059	0.843	NA
	Towards Ground	0.909	0.059	0.968	NA
	Towards Phantom with headset	/	/	/	NA
	Towards Ground with headset	0.272	0.059	0.331	NA

Note: Simultaneous Tx Combination of UMTS Band II and BT

Test Position		Scaled SAR _{Max}		Σ _{1-g} SAR	SPLSP
		UMTS Band IV	BT		
Head	Left Hand Touched	0.158	0.117	0.275	NA
	Left Hand Tilted 15°	0.215	0.117	0.332	NA
	Right Hand Touched	0.178	0.117	0.295	NA
	Right Hand Tilted 15°	0.171	0.117	0.288	NA
Body	Towards Phantom	0.307	0.059	0.366	NA
	Towards Ground	0.293	0.059	0.352	NA
	Towards Phantom with headset	0.258	0.059	0.317	NA
	Towards Ground with headset	/	/	/	NA

Note: Simultaneous Tx Combination of UMTS Band IV and BT

Test Position		Scaled SAR _{Max}		Σ _{1-g} SAR	SPLSP
		UMTS Band V	BT		
Head	Left Hand Touched	0.293	0.117	0.410	NA
	Left Hand Tilted 15°	0.244	0.117	0.361	NA
	Right Hand Touched	0.278	0.117	0.395	NA
	Right Hand Tilted 15°	0.188	0.117	0.305	NA
Body	Towards Phantom	0.314	0.059	0.373	NA
	Towards Ground	0.297	0.059	0.356	NA
	Towards Phantom with headset	0.26	0.059	0.319	NA
	Towards Ground with headset	/	/	/	NA

Note: Simultaneous Tx Combination of UMTS Band V and BT

Test Position		Scaled SAR _{Max}		Σ _{1-g} SAR	SPLSP
		LTE Band II	BT		
Head	Left Hand Touched	0.099	0.117	0.216	NA
	Left Hand Tilted 15°	0.086	0.117	0.203	NA
	Right Hand Touched	0.098	0.117	0.215	NA
	Right Hand Tilted 15°	0.055	0.117	0.172	NA
Body	Towards Phantom	0.748	0.059	0.807	NA
	Towards Ground	1.042	0.059	1.101	NA
	Towards Phantom with headset	/	/	/	NA
	Towards Ground with headset	/	/	/	NA

Note: Simultaneous Tx Combination of LTE Band II and BT

Test Position		Scaled SAR _{Max}		Σ _{1-g} SAR	SPLSP
		LTE Band IV	BT		
Head	Left Hand Touched	0.101	0.117	0.218	NA
	Left Hand Tilted 15°	0.093	0.117	0.210	NA
	Right Hand Touched	0.101	0.117	0.218	NA
	Right Hand Tilted 15°	0.071	0.117	0.188	NA
Body	Towards Phantom	0.78	0.059	0.839	NA
	Towards Ground	1.011	0.059	1.070	NA
	Towards Phantom with headset	/	/	/	NA
	Towards Ground with headset	/	/	/	NA

Note: Simultaneous Tx Combination of LTE Band IV and BT

Test Position		Scaled SAR _{Max}		Σ _{1-g} SAR	SPLSP
		LTE Band VII	BT		
Head	Left Hand Touched	0.076	0.117	0.193	NA
	Left Hand Tilted 15°	0.06	0.117	0.177	NA
	Right Hand Touched	0.066	0.117	0.183	NA
	Right Hand Tilted 15°	0.058	0.117	0.175	NA
Body	Towards Phantom	0.776	0.059	0.835	NA
	Towards Ground	0.938	0.059	0.997	NA
	Towards Phantom with headset	/	/	/	NA
	Towards Ground with headset	/	/	/	NA

Note: Simultaneous Tx Combination of LTE Band VII and BT

Test Position		Scaled SAR _{Max}		Σ _{1-g} SAR	SPLSP
		LTE Band XX	BT		
Head	Left Hand Touched	0.058	0.117	0.175	NA
	Left Hand Tilted 15°	0.055	0.117	0.172	NA
	Right Hand Touched	0.064	0.117	0.181	NA
	Right Hand Tilted 15°	0.038	0.117	0.155	NA
Body	Towards Phantom	0.771	0.059	0.830	NA
	Towards Ground	0.541	0.059	0.600	NA
	Towards Phantom with headset	/	/	/	NA
	Towards Ground with headset	/	/	/	NA

Note: Simultaneous Tx Combination of LTE Band XX and BT

Test Position		Scaled SAR _{Max}		Σ _{1-g} SAR	SPLSP
		LTE Band XXVIII	BT		
Head	Left Hand Touched	0.097	0.117	0.214	NA
	Left Hand Tilted 15°	0.086	0.117	0.203	NA
	Right Hand Touched	0.098	0.117	0.215	NA
	Right Hand Tilted 15°	0.069	0.117	0.186	NA
Body	Towards Phantom	0.775	0.059	0.834	NA
	Towards Ground	0.926	0.059	0.985	NA
	Towards Phantom with headset	/	/	/	NA
	Towards Ground with headset	/	/	/	NA

Note: Simultaneous Tx Combination of LTE Band XXVIII and BT

MAX.ΣSAR_{1g} = 1.101W/kg < 1.6 W/kg, so the Simultaneous SAR is not required for BT and GSM&UMTS<E antenna.

11 Measurement uncertainty evaluation

11.1 Measurement uncertainty evaluation for SAR test

The following table includes the uncertainty table of the IEEE 1528. The values are determined by Satimo. The breakdown of the individual uncertainties is as follows:

Measurement Uncertainty evaluation for SAR test								
Uncertainty Component	Tol. (±%)	Prob. Dist.	Div.	C _i (1g)	C _i (10g)	1g U _i (±%)	10g U _i (±%)	V _i
measurement system								
Probe Calibration	5.8	N	1	1	1	5.8	5.8	∞
Axial Isotropy	3.5	R	$\sqrt{3}$	$(1-C_p)^{1/2}$	$(1-C_p)^{1/2}$	1.43	1.43	∞
Hemispherical Isotropy	5.9	R	$\sqrt{3}$	$\sqrt{C_p}$	$\sqrt{C_p}$	2.41	2.41	∞
Boundary Effect	1	R	$\sqrt{3}$	1	1	0.58	0.58	∞
Linearity	4.7	R	$\sqrt{3}$	1	1	2.71	2.71	∞
system Detection Limits	1	R	$\sqrt{3}$	1	1	0.58	0.58	∞
Modulation response	3	N	1	1	1	3.00	3.00	∞
Readout Electronics	0.5	N	1	1	1	0.50	0.50	∞
Response Time	0	R	$\sqrt{3}$	1	1	0.00	0.00	∞
Integration Time	1.4	R	$\sqrt{3}$	1	1	0.81	0.81	∞
RF Ambient Conditions-Noise	3	R	$\sqrt{3}$	1	1	1.73	1.73	∞
RF Ambient Conditions-Reflections	3	R	$\sqrt{3}$	1	1	1.73	1.73	∞
Probe Positioner Mechanical Tolerance	1.4	R	$\sqrt{3}$	1	1	0.81	0.81	∞
Probe positioning with respect to Phantom Shell	1.4	R	$\sqrt{3}$	1	1	0.81	0.81	∞
Extrapolation, interpolation and Integration Algorithms for Max.SAR Evaluation	2.3	R	$\sqrt{3}$	1	1	1.33	1.33	∞
Test sample Related								
Test Sample Positioning	2.6	N	1	1	1	2.60	2.60	11
Device Holder Uncertainty	3	N	1	1	1	3.00	3.00	7
Output Power Variation-SAR drift measurement	5	R	$\sqrt{3}$	1	1	2.89	2.89	∞
SAR scaling	2	R	$\sqrt{3}$	1	1	1.15	1.15	∞
Phantom and Tissue Parameters								
Phantom Uncertainty (shape and thickness tolerances)	4	R	$\sqrt{3}$	1	1	2.31	2.31	∞
Uncertainty in SAR correction for deviation (in permittivity and conductivity)	2	N	1	1	0.84	2.00	1.68	∞
Liquid conductivity (meas.)	2.5	N	1	0.64	0.43	1.60	1.08	5
Liquid conductivity (target.)	5	R	$\sqrt{3}$	0.64	0.43	1.85	1.24	5
Liquid Permittivity (meas.)	2.5	N	1	0.60	0.49	1.50	1.23	∞
Liquid Permittivity (target.)	5	R	$\sqrt{3}$	0.60	0.49	1.73	1.42	∞
Combined Standard Uncertainly		Rss				10.63	10.54	
Expanded Uncertainty{95% CONFIDENCE INTERVAL}		k				21.26	21.08	

11.2 Measurement uncertainty evaluation for system check

The following table includes the uncertainty table of the IEEE 1528. The values are determined by Satimo. The breakdown of the individual uncertainties is as follows:

Uncertainty For System Performance Check								
Uncertainty Component	Tol. (±%)	Prob. Dist.	Div.	C _i 1g	C _i 10g	1g U _i (±%)	10g U _i (±%)	V _i
measurement system								
Probe Calibration	5.8	N	1	1	1	5.80	5.80	∞
Axial Isotropy	3.5	R	$\sqrt{3}$	$(1-C_p)^{1/2}$	$(1-C_p)^{1/2}$	1.43	1.43	∞
Hemispherical Isotropy	5.9	R	$\sqrt{3}$	$\sqrt{C_p}$	$\sqrt{C_p}$	2.41	2.41	∞
Boundary Effect	1	R	$\sqrt{3}$	1	1	0.58	0.58	∞
Linearity	4.7	R	$\sqrt{3}$	1	1	2.71	2.71	∞
system detection Limits	1	R	$\sqrt{3}$	1	1	0.58	0.58	∞
Modulation response	0	N	1	1	1	0.00	0.00	∞
Readout Electronics	0.5	N	1	1	1	0.50	0.50	∞
Response Time	0	R	$\sqrt{3}$	1	1	0.00	0.00	∞
Integration Time	1.4	R	$\sqrt{3}$	1	1	0.81	0.81	∞
RF ambient Conditions - Noise	3	R	$\sqrt{3}$	1	1	1.73	1.73	∞
RF ambient Conditions – Reflections	3	R	$\sqrt{3}$	1	1	1.73	1.73	∞
Probe positioned Mechanical Tolerance	1.4	R	$\sqrt{3}$	1	1	0.81	0.81	∞
Probe positioning with respect to Phantom Shell	1.4	R	$\sqrt{3}$	1	1	0.81	0.81	∞
Extrapolation, interpolation and integration Algorithms for Max. SAR Evaluation	2.3	R	$\sqrt{3}$	1	1	1.33	1.33	∞
Dipole								
Deviation of experimental source from numerical source	4	N	1	1	1	4.00	4.00	∞
Input power and SAR drift measurement	5	R	$\sqrt{3}$	1	1	2.89	2.89	∞
Dipole axis to liquid Distance	2	R	$\sqrt{3}$	1	1	1.16	1.16	∞
Phantom and Tissue Parameters								
Phantom Uncertainty (shape and thickness tolerances)	4	R	$\sqrt{3}$	1	1	2.31	2.31	∞
Uncertainty in SAR correction for deviation (in permittivity and conductivity)	2	N	1	1	0.84	2.00	1.68	∞
Liquid conductivity (meas.)	2.5	N	1	0.64	0.43	1.60	1.08	5
Liquid conductivity (target.)	5	R	$\sqrt{3}$	0.64	0.43	1.85	1.24	5
Liquid Permittivity (meas.)	2.5	N	1	0.60	0.49	1.50	1.23	∞
Liquid Permittivity (target.)	5	R	$\sqrt{3}$	0.60	0.49	1.73	1.41	∞
Combined Standard Uncertainty		Rss				10.28	9.98	
Expanded Uncertainty (95% Confidence interval)		k				20.57	19.95	

12 Test equipment and ancillaries used for tests

To simplify the identification of the test equipment and/or ancillaries which were used, the reporting of the relevant test cases only refer to the test item number as specified in the table below.

	Manufacturer	Device Type	Type(Model)	Serial number	calibration	
					Last Cal.	Due Date
<input checked="" type="checkbox"/>	SATIMO	COMOSAR DOSIMETRIC E FIELD PROBE	SSE5	SN 09/13 EP170	2014-05-07	2015-05-06
<input checked="" type="checkbox"/>	SATIMO	COMOSAR 835 MHz REFERENCE DIPOLE	SID835	SN 14/13 DIP0G835-235	2014-05-07	2015-05-06
<input type="checkbox"/>	SATIMO	COMOSAR 900 MHz REFERENCE DIPOLE	SID900	SN 14/13 DIP0G900-231	2014-05-07	2015-05-06
<input checked="" type="checkbox"/>	SATIMO	COMOSAR 1800 MHz REFERENCE DIPOLE	SID1800	SN 14/13 DIP1G800-232	2014-05-07	2015-05-06
<input checked="" type="checkbox"/>	SATIMO	COMOSAR 1900 MHz REFERENCE DIPOLE	SID1900	SN 14/13 DIP1G900-236	2014-05-07	2015-05-06
<input type="checkbox"/>	SATIMO	COMOSAR 2000 MHz REFERENCE DIPOLE	SID2000	SN 14/13 DIP2G000-237	2014-05-07	2015-05-06
<input checked="" type="checkbox"/>	SATIMO	COMOSAR 2450 MHz REFERENCE DIPOLE	SID2450	SN 14/13 DIP2G450-238	2014-05-07	2015-05-06
<input type="checkbox"/>	SATIMO	COMOSAR 2600 MHz REFERENCE DIPOLE	SID2600	SN 28/14 DIP2G600-327	2014-07-10	2015-07-09
<input checked="" type="checkbox"/>	SATIMO	Software	OPENSAR	N/A	N/A	N/A
<input checked="" type="checkbox"/>	SATIMO	Phantom	COMOSAR IEEE SAM PHANTOM	SN 14/13 SAM99	N/A	N/A
<input checked="" type="checkbox"/>	R & S	Universal Radio Communication Tester	CMU 200	117528	2014-08-19	2015-08-18
<input checked="" type="checkbox"/>	HP	Network Analyser	8753D	3410A08889	2014-08-19	2015-08-18
<input checked="" type="checkbox"/>	HP	Signal Generator	E4421B	GB39340770	2014-08-19	2015-08-18
<input checked="" type="checkbox"/>	Keithley	Multimeter	Keithley 2000	4014539	2014-08-19	2015-08-18
<input checked="" type="checkbox"/>	SATIMO	Amplifier	Power Amplifier	MODU-023-A- 0004	2014-10-13	2015-10-12
<input checked="" type="checkbox"/>	Agilent	Power Meter	E4418B	GB43312909	2014-10-13	2015-10-12
<input checked="" type="checkbox"/>	Agilent	Power Meter Sensor	E4412A	MY41500046	2014-10-13	2015-10-12
<input checked="" type="checkbox"/>	Agilent	Power Meter	E4417A	GB41291826	2014-10-13	2015-10-12
<input checked="" type="checkbox"/>	Agilent	Power Meter Sensor	8481H	MY41091215	2014-10-13	2015-10-12

Annex A: System performance verification

(Please See the SAR Measurement Plots of annex A.)

Annex B: Measurement results

(Please See the SAR Measurement Plots of annex B.)

Annex C: Calibration reports

(Please See the Calibration reports of annex C.)

Annex D: Photo documentation

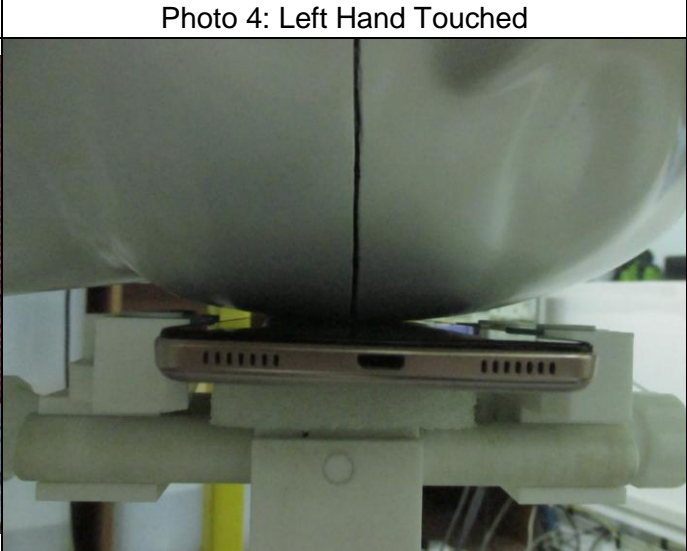
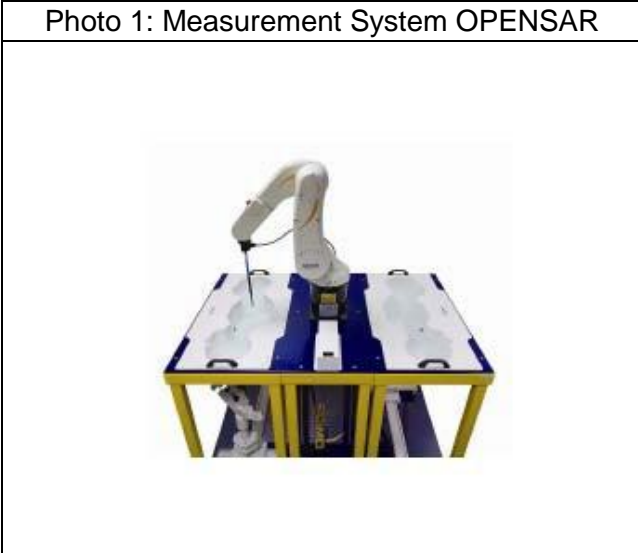

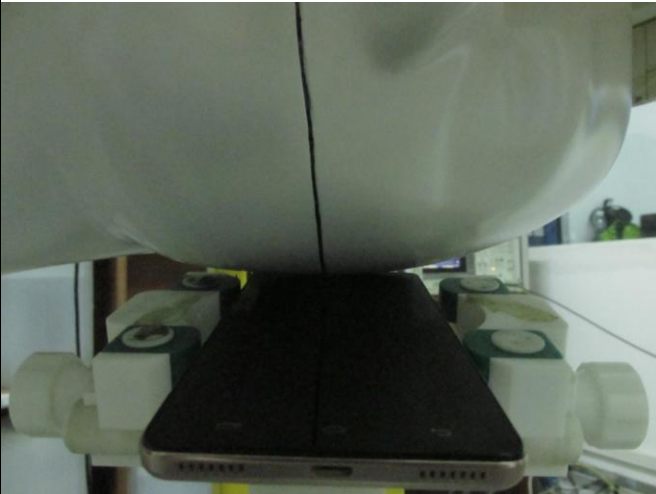

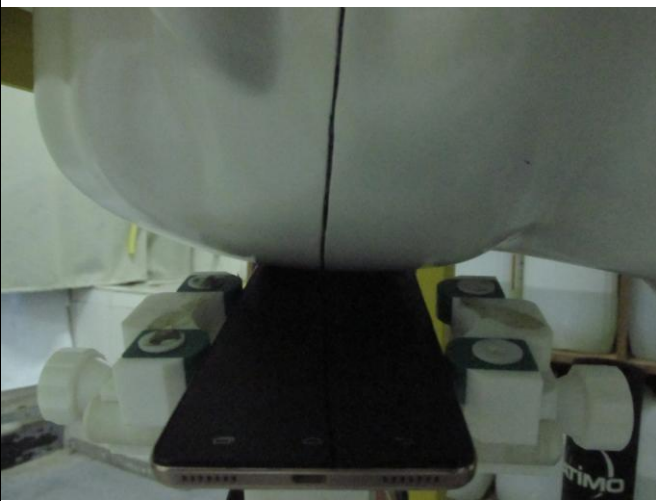

Photo 5: Left Hand Tilted 15°	Photo 6: Right Hand Touched
 A photograph showing a white phantom head tilted to the left. A smartphone is mounted on a stand below the head, tilted at a 15-degree angle. The background shows laboratory equipment.	 A photograph showing a white phantom head. A smartphone is mounted on a stand below the head, positioned as if being touched by the right hand. The background shows laboratory equipment.
Photo 7: Right Hand Tilted 15°	Photo 8: Towards Phantom 10mm
 A photograph showing a white phantom head tilted to the right. A smartphone is mounted on a stand below the head, tilted at a 15-degree angle. The background shows laboratory equipment.	 A photograph showing a white phantom head. A smartphone is mounted on a stand below the head, positioned towards the phantom. A red double-headed arrow indicates a distance of 10mm between the phone and the phantom. The background shows laboratory equipment.

Photo 9: Towards Ground 10mm

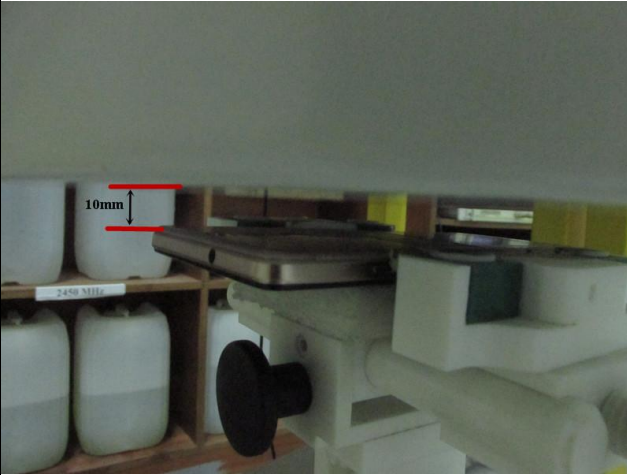

Photo 10: Towards Phantom with Headset10mm

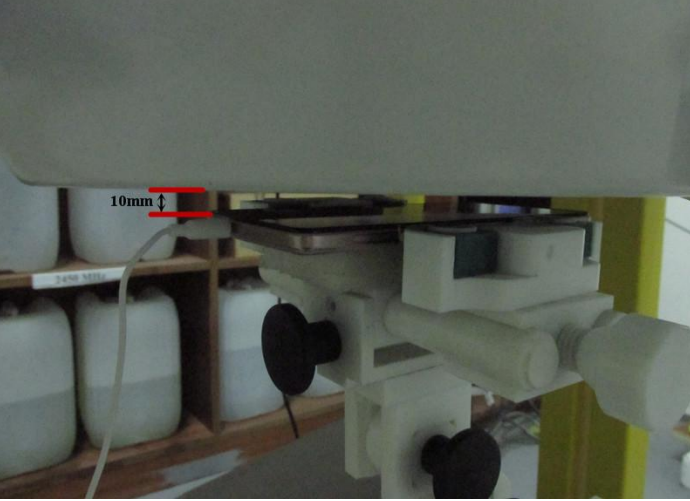

Photo 11: Towards Ground with Headset10mm

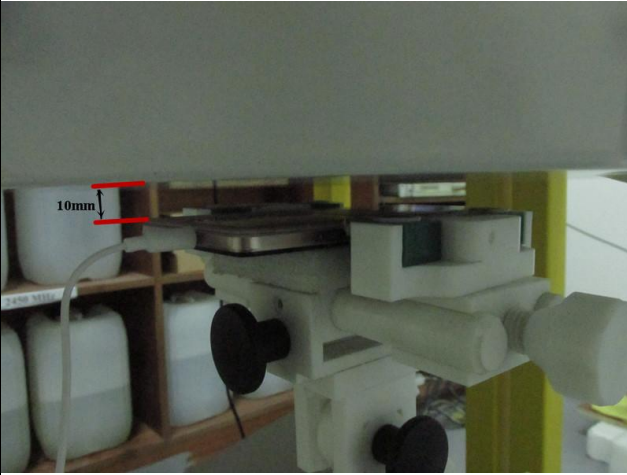

Photo 11: 850MHz Liquid Depth $\geq 15.0\text{cm}$

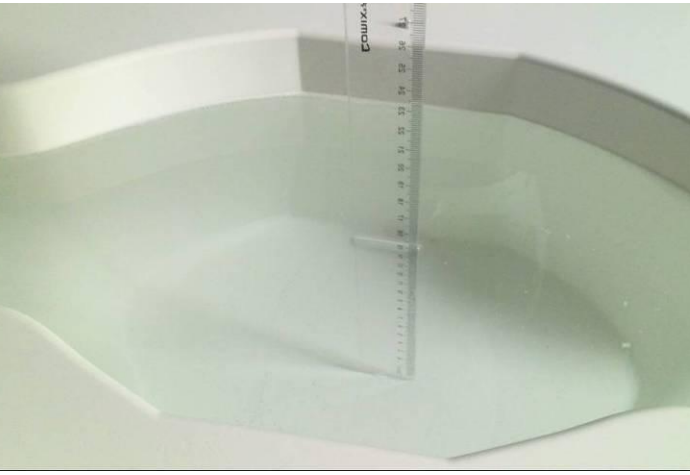



Photo 13: 1800~1900MHz Liquid Depth \geq 15.0cm	Photo 14: 2450MHz Liquid Depth \geq 15.0cm
	

End