



LTE RADIO TEST REPORT

Report No: STS1606006F05

Issued for

Carreras Consulting Inc

561 Ensenada Street Suite 3A San Juan P.R. 00907Puerto Rico

Product Name:	SMART PHONE
Brand Name:	Six Mobile
Model Name:	Signus Pro
Series Model:	Signus
FCC ID:	2AIYZSIGNUSPRO
Test Standard:	FCC Part 22H FCC Part 24E FCC Part 27L/M

Any reproduction of this document must be done in full. No single part of this document may be reproduced without permission from STS, All Test Data Presented in this report is only applicable to presented Test sample.





TEST RESULT CERTIFICATION

Applicant's name Carreras Consulting Inc
Address 561 Ensenada Street Suite 3A San Juan P.R. 00907Puerto Rico
Manufacture's Name Cola Multimedia Limited
Address Room 603,6/F, Hang pont commercial building,31 Tonkin street,Cheung sha wan,Kowloon,Hongkong
Product name SMART PHONE
Brand name Six Mobile
Model and/or type reference.. Signus Pro
Standards FCC Part 24H. FCC Part 24E. FCC Part 27L/M
Test procedure ANSI / TIA 603-D-2010

This device described above has been tested by STS and the test results show that the equipment under test (EUT) is in compliance with the FCC requirements. And it is applicable only to the tested sample identified in the report.

This report shall not be reproduced except in full, without the written approval of STS, this document may be altered or revised by STS, personal only, and shall be noted in the revision of the document.

Date of Test
Date of performance of tests 06 June. 2016~20 June. 2016
Date of Issue 21 June. 2016
Test Result Pass

Testing Engineer : [Signature]
(Jin Ming)

Technical Manager : [Signature]
(Tony Liu)

Authorized Signatory : [Signature]
(Bovey Yang)





TABLE OF CONTENTS	Page
1. SUMMARY OF TEST RESULTS	5
2. GENERAL INFORMATION	8
3. CONDUCTED OUTPUT POWER	17
4. PEAK-TO-AVERAGE RATIO	26
5. RADIATED POWER AND EFFECTIVE ISOTROPIC RADIATED POWER	29
6. OCCUPIED BANDWIDTH	36
7. CONDUCTED BAND EDGE	53
8. CONDUCTED SPURIOUS EMISSION	83
9. RADIATED SPURIOUS EMISSION	98
10. FREQUENCY STABILITY	114
PHOTOS OF TEST SETUP	118

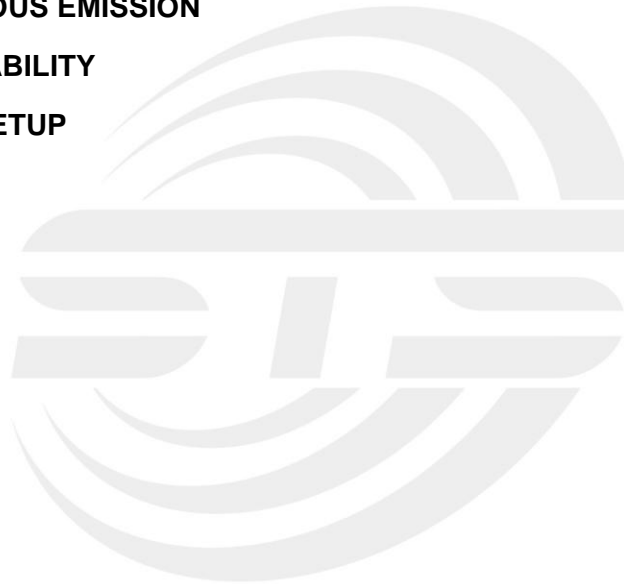

**Revision History**

Rev.	Issue Date	Report NO.	Effect Page	Contents
00	16 June. 2016	STS1606006F05	ALL	Initial Issue





1. SUMMARY OF TEST RESULTS

1.1 TEST RESULTS DESCRIPTION AND LABORATORY INFORMATION

Setion	FCC Rule	Description	Limit	Result
	§2.1046	Conducted Output Power	Reporting Only	PASS
	§24.232(d)	Peak-to-Average Ratio	<13 dB	PASS
	§2.1049 §24.238(b) §27.53(h)(3) §27.53(m)(6)	Occupied Bandwidth	Reporting Only	PASS
	§2.1051 §24.238(a) §27.53(g) §27.53(h)	Conducted Band Edge Measurement (Band 2)(Band 4) (Band 17)	<43+10log10(P[Watts])	PASS
	§27.53(m)(4/6)	(Band 7)	<43+10log10(P[Watts])	PASS
	§2.1051 §24.238(a) §27.53(g) §27.53(h)	Conducted Spurious Emission (Band 2)(Band 4) (Band 17)	<43+10log10(P[Watts])	PASS
	§27.53(m)(4/6)	Conducted Spurious Emission (Band 7)	< 55+10log10(P[Watts])	PASS



	§27.50(c)(10)	Effective Radiated Power (Band 17)	ERP < 3 Watt	PASS
	§24.232(c)	Equivalent Isotropic Radiated Power (Band 2)	EIRP < 2Watt	PASS
	§27.50(d)(4)	Equivalent Isotropic Radiated Power (Band 4)	EIRP < 1Watt	PASS
	§2.1051 §24.238(a) §27.53(g) §27.53(h)	Radiated Spurious Emission (Band 2)(Band 4) (Band 17)	< 43+10log ₁₀ (P[Watts])	PASS
	§27.53(m)(4)(6)	Radiated Spurious Emission (Band 7)	< 55+10log ₁₀ (P[Watts])	PASS



1.1.1 TEST FACTORY

Shenzhen STS Test Services Co., Ltd.

Add. : 1/F., Building B, Zhuoke Science Park, No.190, Chongqing Road,
Fuyong Street, Bao'an District, Shenzhen, Guangdong,China
CNAS Registration No.: L7649;

FCC Registration No.: 842334; IC Registration No.: 12108A-1

1.1.2 MEASUREMENT UNCERTAINTY

The reported uncertainty of measurement $y \pm U$, where expanded uncertainty U is based on a standard uncertainty multiplied by a coverage factor of $k=2$, providing a level of confidence of approximately **95** %.

No.	Item	Uncertainty
1	Conducted Emission (9KHz-150KHz)	$\pm 2.88\text{dB}$
2	Conducted Emission (150KHz-30MHz)	$\pm 2.67\text{dB}$
3	RF power,conducted	$\pm 0.70\text{dB}$
4	Spurious emissions,conducted	$\pm 1.19\text{dB}$
5	All emissions,radiated(<1G) 30MHz-200MHz	$\pm 2.83\text{dB}$
6	All emissions,radiated(<1G) 200MHz-1000MHz	$\pm 2.94\text{dB}$
7	All emissions,radiated(>1G)	$\pm 3.03\text{dB}$
8	Temperature	$\pm 0.5^{\circ}\text{C}$
9	Humidity	$\pm 2\%$



2. GENERAL INFORMATION

2.1 TECHNICAL SPECIFICATIONS AND REGULATIONS

2.1.1 PRODUCT DESCRIPTION

A major technical description of EUT is described as following:

Product Designation:	SMART PHONE
Hardware version:	V2.0
Software version:	N/A
FCC ID:	2AIYZSIGNUSPRO
Frequency Bands:	U.S. Bands: <input checked="" type="checkbox"/> LTE FDD Band 2 <input checked="" type="checkbox"/> LTE FDD Band 4 <input type="checkbox"/> LTE FDD Band 5 <input type="checkbox"/> LTE FDD Band 7 <input type="checkbox"/> LTE FDD Band 12 <input type="checkbox"/> LTE FDD Band 13 <input checked="" type="checkbox"/> LTE FDD Band 17
SIM CARD:	SIM 1 and SIM 2 is a chipset unit and tested as single chipset, SIM 1 is used to tested
Antenna:	PIFA Antenna
Antenna gain:	LTE Band 17: -2.5dBi LTE Band 4: -2.3dBi LTE Band 2: -2.6dBi
Power Supply:	DC 3.8V by battery or DC 4.2V supplied by adapter
Battery parameter:	Capacitance: 1700mA, Rated Voltage: 3.8V
Adapter Input:	AC100-240V, 50-60Hz, 0.2A
Adapter Output:	DC 5.0V, 1A



2.1.2 PRODUCT SPECIFICATION SUBJECTIVE TO THIS STANDARD

Product Specification Subjective To This Standard	
Tx Frequency	LTE Band 2:1850.7~1909.3MHz LTE Band 4:1710.7~1754.3MHz LTE Band 17:706.5~713.5MHz
Rx Frequency	LTE Band 2:1930.7~1989.3MHz LTE Band 4:2110.7~2154.3MHz LTE Band 17:736.5~743.5MHz
Bandwidth	LTE Band 2 : 1.4MHz / 3MHz / 5MHz / 10MHz / 15MHz / 20MHz LTE Band 4 : 1.4MHz / 3MHz / 5MHz / 10MHz / 15MHz / 20MHz LTE Band 17 : 5MHz / 10MHz
Maximum Output Power Limit	LTE Band 2 : 22.20 dBm LTE Band 4 : 23.85 dBm LTE Band 17 : 24.35 dBm
Type of Modulation	QPSK / 16QAM





2.1.3 EMISSION DESIGNATOR

LTE Band 2 BW(MHz)	Emission Designator (99%OBW)QPSK	Emission Designator (99%OBW)16QAM
1.4	1M11G7D	1M10W7D
3	2M69G7D	2M69W7D
5	4M49G7D	4M49W7D
10	8M96G7D	8M96W7D
15	13M43G7D	13M43W7D
20	17M91G7D	17M92W7D

LTE Band 4 BW(MHz)	Emission Designator (99%OBW)QPSK	Emission Designator (99%OBW)16QAM
1.4	1M10G7D	1M11W7D
3	2M69G7D	2M69W7D
5	4M49G7D	4M49W7D
10	8M96G7D	8M97W7D
15	13M46G7D	13M44W7D
20	17M94G7D	17M95W7D

LTE Band 17 BW(MHz)	Emission Designator (99%OBW)QPSK	Emission Designator (99%OBW)16QAM
5	4M50G7D	4M49W7D
10	8M97G7D	8M97W7D



2.1.4 TEST CONFIGURATION OF EQUIPMENT UNDER TEST

Antenna port conducted and radiated test items listed below are performed according to KDB 971168 D02 Power Meas. License Digital Systems v02r02 with maximum output power. Radiated measurements are performed by rotating the EUT in three different orthogonal test planes to find the maximum emission.

Remark:

1. The mark “v “ means that this configuration is chosen for testing
2. The mark “-“ means that this bandwidth is not supported.
3. The device is investigated from 30MHz to 10 times of fundamental signal for radiated

ITEMS	Band	Bandwidth (MHz)						Modulation		RB #			Test Channel		
		1.4	3	5	10	15	20	QPSK	16QAM	1	Half	Full	L	M	H
Max. Output Power	2	v	v	v	v	v	v	v	v	v	v	v	v	v	v
	4	v	v	v	v	v	v	v	v	v	v	v	v	v	v
	17	-	-	v	v	-	-	v	v	v	v	v	v	v	v
Peak&Avera Ratio	2						v	v	v	v		v	v	v	v
	4						v	v	v	v		v	v	v	v
	17	-	-		v	-	-	v	v	v		v	v	v	v
26dB&99% Bandwidth	2	v	v	v	v	v	v	v	v			v	v	v	v
	4	v	v	v	v	v	v	v	v			v	v	v	v
	17	-	-	v	v	-	-	v	v			v	v	v	v
Conducted Band Edge	2	v	v	v	v	v	v	v	v	v		v	v	v	v
	4	v	v	v	v	v	v	v	v	v		v	v	v	v
	17	-	-	v	v	-	-	v	v	v		v	v	v	v



ITEMS	Band	Bandwidth (MHz)						Modulation		RB #			Test Channel		
		1.4	3	5	10	15	20	QPSK	16QAM	1	Half	Full	L	M	H
Conducted Spurious Emission	2	v	v	v	v	v	v	v	v	v			v	v	v
	4	v	v	v	v	v	v	v	v	v			v	v	v
	17	-	-	v	v	-	-	v	v	v			v	v	v
Frequency Stability	2				v			v				v		v	
	4				v			v				v		v	
	17	-	-		v	-	-	v				v		v	
E.R.P.& E.I.R.P.	2	v	v	v	v	v	v	v	v	v			v	v	v
	4	v	v	v	v	v	v	v	v	v			v	v	v
	17	-	-	v	v	-	-	v	v	v			v	v	v
Radiated Spurious Emission	2	v	v	v	v	v	v	v		v			v	v	v
	4	v	v	v	v	v	v	v		v			v	v	v
	17	-	-	v	v	-	-	v		v			v	v	v





2.1.5 RELATED SUBMITTAL(S) / GRANT (S)

This submittal(s) (test report) is intended for filing to comply with the FCC part 22H&24E&27.

2.1.6 SPECIAL ACCESSORIES

The battery and the charger, earphone supplied by the applicant were used as accessories and being tested with eut intended for fcc grant together.

2.1.7 EUT CONFIGURATION

The EUT configuration for testing is installed on RF field strength measurement to meet the Commission's requirement and operating in a manner which intends to maximize its emission characteristics in a continuous normal application.

2.1.8 EUT EXERCISE

The Transmitter was operated in the maximum output power mode through Communication Tester. The TX frequency was fixed which was for the purpose of the measurements.

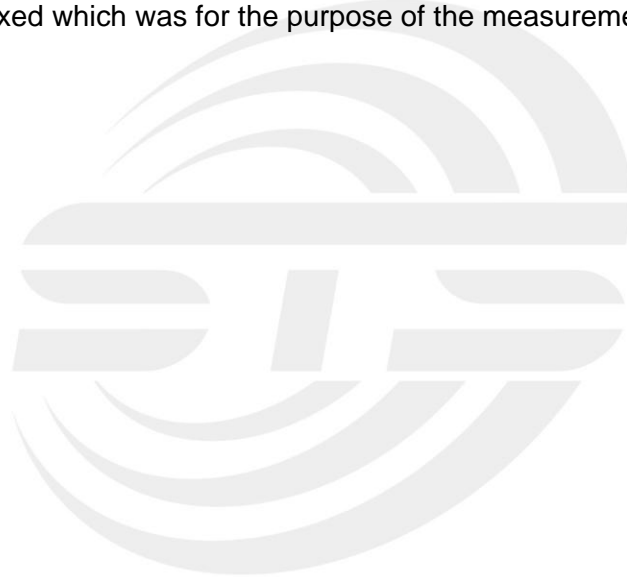



2.1.9 CONFIGURATION OF EUT SYSTEM

The EUT configuration for testing is installed on RF field strength measurement to meet the Commission's requirement and operating in a manner which intends to maximize its emission characteristics in a continuous normal application.



Table 2-1 Equipment Used in EUT System

Item	Equipment	Model Name	Serial No.	Note
E-1	SMART PHONE	Signus Pro	N/A	N/A

Note:

- (1) The support equipment was authorized by Declaration of Confirmation.
- (2) For detachable type I/O cable should be specified the length in cm in 『Length』 column.



2.1.10 MEASUREMENT INSTRUMENTS

The radiated emission testing was performed according to the procedures of ansi ANSI / TIA 603-D-2010 and FCC CFR 47 rules of 2.1046, 2.1047, 2.1049, 2.1051, 2.1053, 2.1055, 2.1057.

Kind of Equipment	Manufacturer	Type No.	Serial No.	Last Calibration	Calibrated Until
Spectrum Analyzer	Agilent	E4407B	MY50140340	2015.10.25	2016.10.24
Test Receiver	R&S	ESCI	101427	2015.10.25	2016.10.24
Communication Tester	Agilent	8960	MY48360751	2015.11.20	2016.11.19
Communication Tester	R&S	CMU200	112012	2015.10.25	2016.10.24
Test Receiver	R&S	ESCI	102086	2015.10.25	2016.10.24
Bilog Antenna (measurement)	TESEQ	CBL6111D (30MHz-1GHz)	34678	2015.11.25	2016.11.24
Horn Antenna (measurement)	Schwarzbeck	BBHA 9120D(1201) (1GHz-18GHz)	9120D-1343	2016.03.06	2017.03.05
STS-E048	MXA SIGNAL Analyzer	Agilent	N9020A	2015.10.25	2016.10.24
Logarithm -Antenna(substituted)	Schwarzbeck	VUSLP 9111 (200MHz-4GHz)	9111-512	2015.09.03	2016.09.02
Horn-Antenna(substituted)	Schwarzbeck	BBHA9120D (1GHz-18GHz)	D:266	2016.03.06	2017.03.05



2. 1.11 MEASUREMENT RESULTS EXPLANATION EXAMPLE

For all conducted test items:

The offset level is set in the spectrum analyzer to compensate the RF cable loss and attenuator factor between EUT conducted output port and spectrum analyzer. With the offset compensation, the spectrum analyzer reading level is exactly the EUT RF output level.

The spectrum analyzer offset is derived from RF cable loss and attenuator factor.

Offset = RF Cable Loss + Attenuator Factor.



3. CONDUCTED OUTPUT POWER

3.1 DESCRIPTION OF THE CONDUCTED OUTPUT POWER MEASUREMENT

3.1.1 MEASUREMENT METHOD

A System Simulator Was Used To Establish Communication With The EUT. Its Parameters Were Set To Force The EUT Transmitting At Maximum Output Power. The Measured Power In The Radio Frequency On The Transmitter Output Terminals Shall Be Reported.
configuration follows KDB 971168 D01.

3.1.2 TEST SETUP

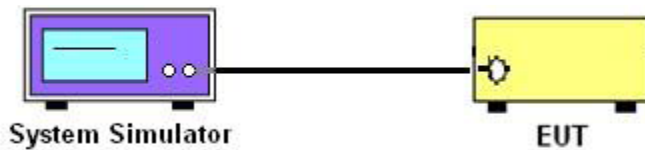

3.1.3 TEST PROCEDURES

1. The Transmitter Output Port Was Connected To The System Simulator.
2. Set EUT at maximum power through the system simulator.
3. Select lowest, middle, and highest channels for each band and different modulation.
4. Measure and record the power level from the system simulator.



3.1.4 TEST RESULTS

LTE BAND 2

LTE Band 2 Maximum Average Power [dBm]						
BW [MHz]	RB Size	RB Offset	Mod	Lowest	Middle	Highest
1.4	1	0	QPSK	22.01	21.87	22.15
1.4	1	2		21.97	21.88	22.19
1.4	1	5		21.98	21.90	22.20
1.4	3	0		21.81	21.70	22.01
1.4	3	1		21.77	21.75	21.97
1.4	3	2		21.83	21.80	22.01
1.4	6	0		21.05	20.98	21.15
1.4	1	0	16-QAM	20.74	20.86	21.02
1.4	1	2		20.74	20.87	20.98
1.4	1	5		20.73	20.91	20.98
1.4	3	0		20.69	20.68	20.83
1.4	3	1		20.64	20.64	20.78
1.4	3	2		20.70	20.67	20.83
1.4	6	0		19.93	19.86	20.07
3	1	0	QPSK	21.72	21.58	21.85
3	1	7		21.67	21.58	21.89
3	1	14		21.69	21.61	21.90
3	8	0		21.51	21.41	21.71
3	8	4		21.47	21.46	21.68
3	8	7		21.54	21.51	21.71
3	15	0		20.76	20.69	20.86
3	1	0	16-QAM	20.44	20.57	20.72
3	1	7		20.45	20.58	20.69
3	1	14		20.44	20.62	20.69
3	8	0		20.40	20.39	20.53
3	8	4		20.34	20.35	20.48
3	8	7		20.40	20.38	20.54
3	15	0		19.63	19.56	19.78



LTE BAND 2

LTE Band 2 Maximum Average Power [dBm]						
BW [MHz]	RB Size	RB Offset	Mod	Lowest	Middle	Highest
5	1	0	QPSK	21.72	21.57	21.85
5	1	12		21.68	21.59	21.89
5	1	24		21.69	21.60	21.91
5	12	0		21.52	21.40	21.71
5	12	6		21.48	21.46	21.68
5	12	11		21.53	21.51	21.71
5	25	0		20.76	20.68	20.86
5	1	0	16-QAM	20.44	20.57	20.73
5	1	12		20.44	20.57	20.69
5	1	24		20.43	20.62	20.69
5	12	0		20.40	20.38	20.53
5	12	6		20.35	20.34	20.48
5	12	11		20.40	20.37	20.53
5	25	0		19.63	19.57	19.77
10	1	0	QPSK	21.62	21.47	21.76
10	1	24		21.58	21.49	21.80
10	1	49		21.59	21.51	21.80
10	25	0		21.42	21.30	21.61
10	25	12		21.37	21.36	21.58
10	25	24		21.43	21.41	21.61
10	50	0		20.65	20.59	20.76
10	1	0	16-QAM	20.35	20.47	20.62
10	1	24		20.35	20.48	20.59
10	1	49		20.33	20.52	20.59
10	25	0		20.29	20.28	20.44
10	25	12		20.24	20.24	20.39
10	25	24		20.31	20.28	20.43
10	50	0		19.54	19.47	19.68



LTE BAND 2

LTE Band 2 Maximum Average Power [dBm]						
BW [MHz]	RB Size	RB Offset	Mod	Lowest	Middle	Highest
15	1	0	QPSK	21.51	21.51	21.51
15	1	37		21.47	21.47	21.47
15	1	74		21.48	21.48	21.48
15	36	0		21.32	21.32	21.32
15	36	18		21.28	21.28	21.28
15	36	39		21.34	21.34	21.34
15	75	0		20.56	20.56	20.56
15	1	0	16-QAM	20.25	20.25	20.25
15	1	38		20.25	20.25	20.25
15	1	75		20.23	20.23	20.23
15	36	0		20.20	20.20	20.20
15	36	18		20.14	20.14	20.14
15	36	39		20.20	20.20	20.20
15	75	0		19.44	19.44	19.44
20	1	0	QPSK	21.71	21.58	21.86
20	1	49		21.68	21.59	21.89
20	1	99		21.68	21.61	21.90
20	50	0		21.51	21.40	21.71
20	50	24		21.47	21.45	21.67
20	50	49		21.53	21.51	21.72
20	100	0		20.75	20.68	20.85
20	1	0	16-QAM	20.45	20.57	20.72
20	1	49		20.44	20.57	20.68
20	1	99		20.43	20.62	20.68
20	50	0		20.39	20.39	20.53
20	50	24		20.34	20.35	20.48
20	50	49		20.41	20.37	20.53
20	100	0		19.64	19.56	19.78



LTE BAND 4

LTE Band 4 Maximum Average Power [dBm]						
BW [MHz]	RB Size	RB Offset	Mod	Lowest	Middle	Highest
1.4	1	0	QPSK	23.68	23.78	23.58
1.4	1	2		23.73	23.79	23.64
1.4	1	5		23.71	23.83	23.66
1.4	3	0		23.04	22.88	22.80
1.4	3	1		22.67	22.76	22.74
1.4	3	3		22.90	22.79	22.77
1.4	6	0		21.68	21.97	21.67
1.4	1	0	16-QAM	23.50	23.50	23.42
1.4	1	2		23.49	23.46	23.36
1.4	1	5		23.31	23.39	23.37
1.4	3	0		22.95	22.96	22.98
1.4	3	1		22.98	22.83	23.11
1.4	3	3		22.88	22.90	23.08
1.4	6	0		22.28	21.70	21.98
3	1	0	QPSK	23.63	23.75	23.61
3	1	7		23.72	23.76	23.64
3	1	14		23.73	23.85	23.67
3	8	0		23.03	22.88	22.79
3	8	4		22.66	22.77	22.78
3	8	8		22.90	22.79	22.78
3	15	0		21.69	21.97	21.67
3	1	0	16-QAM	23.49	23.49	23.38
3	1	7		23.50	23.47	23.36
3	1	14		23.31	23.39	23.36
3	8	0		22.95	23.00	23.00
3	8	4		22.95	22.83	23.10
3	8	7		22.86	22.91	23.06
3	15	0		22.30	21.70	21.99



LTE BAND 4

LTE Band 4 Maximum Average Power [dBm]						
BW [MHz]	RB Size	RB Offset	Mod	Lowest	Middle	Highest
5	1	0	QPSK	23.67	23.76	23.58
5	1	12		23.73	23.79	23.65
5	1	24		23.76	23.84	23.66
5	12	0		23.02	22.87	22.79
5	12	6		22.69	22.78	22.77
5	12	11		22.90	22.80	22.75
5	25	0		21.68	21.97	21.68
5	1	0	16-QAM	23.47	23.48	23.41
5	1	12		23.48	23.50	23.39
5	1	24		23.28	23.37	23.37
5	12	0		22.93	22.99	23.00
5	12	6		22.97	22.86	23.10
5	12	11		22.88	22.87	23.06
5	25	0		22.29	21.64	22.01
10	1	0	QPSK	23.63	23.74	23.58
10	1	24		23.75	23.77	23.66
10	1	49		23.74	23.83	23.65
10	25	0		23.04	22.87	22.79
10	25	12		22.68	22.77	22.76
10	25	24		22.90	22.78	22.79
10	50	0		21.68	21.96	21.65
10	1	0	16-QAM	23.47	23.49	23.42
10	1	12		23.47	23.50	23.40
10	1	24		23.32	23.37	23.39
10	25	0		22.94	23.00	23.03
10	25	12		22.95	22.83	23.13
10	25	24		22.91	22.90	23.02
10	50	0		22.26	21.68	22.00



LTE BAND 4

LTE Band 4 Maximum Average Power [dBm]						
BW [MHz]	RB Size	RB Offset	Mod	Lowest	Middle	Highest
15	1	0	QPSK	23.65	23.74	23.58
15	1	37		23.74	23.79	23.66
15	1	75		23.75	23.85	23.68
15	36	0		23.07	22.90	22.81
15	36	18		22.69	22.77	22.78
15	36	37		22.91	22.78	22.80
15	75	0		21.67	21.93	21.66
15	1	0	16-QAM	23.50	23.48	23.40
15	1	37		23.47	23.48	23.37
15	1	74		23.27	23.38	23.36
15	36	0		22.93	22.98	23.01
15	36	18		23.00	22.84	23.11
15	36	36		22.89	22.90	23.07
15	75	0		22.25	21.67	21.99
20	1	0	QPSK	23.66	23.75	23.57
20	1	50		23.71	23.75	23.62
20	1	99		23.75	23.84	23.67
20	50	0		23.03	22.87	22.82
20	50	24		22.68	22.79	22.80
20	50	49		22.91	22.77	22.75
20	100	0		21.68	21.97	21.65
20	1	0	16-QAM	23.47	23.48	23.41
20	1	49		23.48	23.50	23.36
20	1	99		23.30	23.36	23.40
20	50	0		22.94	22.98	22.98
20	50	24		22.96	22.84	23.11
20	50	49		22.88	22.91	23.03
20	100	0		22.26	21.68	21.99





LTE BAND 17

LTE Band 17 Maximum Average Power [dBm]						
BW [MHz]	RB Size	RB Offset	Mod	Lowest	Middle	Highest
5	1	0	QPSK	24.15	24.28	24.09
5	1	12		24.25	24.30	24.14
5	1	24		24.24	24.33	24.17
5	12	0		23.56	23.38	23.29
5	12	6		23.17	23.24	23.28
5	12	11		23.40	23.27	23.27
5	25	0		22.16	22.47	22.16
5	1	0	16-QAM	24.02	23.98	23.88
5	1	12		23.97	24.00	23.89
5	1	24		23.80	23.87	23.90
5	12	0		23.44	23.47	23.48
5	12	6		23.46	23.36	23.59
5	12	11		23.39	23.38	23.53
5	25	0		22.76	22.18	22.47
10	1	0	QPSK	24.17	24.26	24.09
10	1	24		24.22	24.28	24.14
10	1	49		24.22	24.35	24.19
10	25	0		23.53	23.38	23.28
10	25	12		23.15	23.28	23.27
10	25	24		23.38	23.26	23.28
10	50	0		22.16	22.46	22.16
10	1	0	16-QAM	23.98	24.00	23.92
10	1	24		23.99	24.00	23.90
10	1	49		23.79	23.90	23.89
10	25	0		23.44	23.49	23.52
10	25	12		23.45	23.37	23.61
10	25	24		23.40	23.41	23.53
10	50	0		22.78	22.15	22.49

4. PEAK-TO-AVERAGE RATIO

4.1 DESCRIPTION OF THE CONDUCTED OUTPUT POWER MEASUREMENT

4.1.1 MEASUREMENT METHOD

Use one of the procedures presented in 4.1 to measure the total peak power and record as PPk. Use one of the applicable procedures presented 4.2 to measure the total average power and record as PAvg. Both the peak and average power levels must be expressed in the same logarithmic units (e.g., dBm). Determine the PAPR from:
 $PAPR (dB) = PPk (dBm) - PAvg (dBm)$.

4.1.2 TEST SETUP

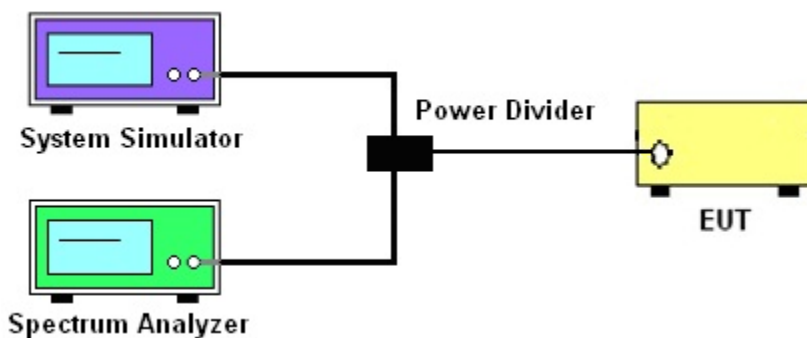

4.1.3 TEST PROCEDURES

1. The testing follows FCC KDB 971168 v02r02 Section 5.7.2..
2. The EUT was connected to spectrum and system simulator via a power divider
3. Select lowest, middle, and highest channels for each band and different modulation.
4. Set the test probe and measure the peak and average power of the spectrum analyzer
5. Record the deviation as Peak to Average Ratio.



	LTE					
LTE BW	1.4M	3M	5M	10M	15M	20M
Span	3MHz	6MHz	10MHz	20MHz	30MHz	40MHz
RBW	30kHz	100kHz	100kHz	300kHz	300kHz	300kHz
VBW	100kHz	300kHz	300kHz	1000kHz	1000kHz	1000kHz
Detector	PK/AVG	PK/AVG	PK/AVG	PK/AVG	PK/AVG	PK/AVG
Trace	Max	Max	Max	Max	Max	Max
Sweep Count	Auto	Auto	Auto	Auto	Auto	Auto

4.1.4 TEST RESULTS

LTE BAND 2

LTE Band 2 PAR [dBm]											
BW [MHz]	RB Size	Mod	Lowest			Middle			Highest		
			PEAK	AVG	P-A	PEAK	AVG	P-A	PEAK	AVG	P-A
20	1	QPSK	25.69	21.71	3.98	25.51	21.61	3.90	25.89	21.90	3.99
20	100		24.75	20.75	4.00	24.39	20.68	3.71	24.82	20.85	3.97
20	1	16-QA	24.50	20.45	4.05	24.52	20.62	3.90	24.58	20.72	3.86
20	100	M	23.63	19.64	3.99	23.15	19.56	3.59	23.26	19.78	3.48
Limit			≤13dBm								

LTE BAND 4

LTE Band 4 PAR [dBm]											
BW [MHz]	RB Size	Mod	Lowest			Middle			Highest		
			PEAK	AVG	P-A	PEAK	AVG	P-A	PEAK	AVG	P-A
20	1	QPSK	27.20	23.75	3.45	27.26	23.84	3.42	27.62	23.67	3.95
20	100		25.27	21.68	3.59	25.68	21.97	3.71	25.31	21.65	3.66
20	1	16-QA	26.79	23.48	3.31	26.89	23.50	3.39	27.03	23.41	3.62
20	100	M	25.82	22.26	3.56	25.20	21.68	3.52	25.98	21.99	3.99
Limit			≤13dBm								



LTE BAND 17

LTE Band 17 PAR [dBm]											
BW [MHz]	RB Size	Mod	Lowest			Middle			Highest		
			PEAK	AVG	P-A	PEAK	AVG	P-A	PEAK	AVG	P-A
10	1	QPSK	28.12	24.22	3.90	27.88	24.35	3.53	27.54	24.19	3.35
10	75		25.82	22.16	3.66	26.05	22.46	3.59	26.16	22.16	4.00
10	1	16-QA	27.64	23.99	3.65	27.99	24.00	3.99	27.63	23.92	3.71
10	75	M	26.57	22.78	3.79	26.23	22.15	4.08	26.56	22.49	4.07
Limit			≤13dBm								



5. RADIATED POWER AND EFFECTIVE ISOTROPIC RADIATED POWER

5.1 DESCRIPTION OF THE ERP/EIRP MEASUREMENT

5.1.1 MEASUREMENT METHOD

Effective radiated power output measurements by substitution method according to ANSI / TIA / EIA-603-C, and the spectrum analyzer configuration follows KDB 971168 D01 Power Meas. License Digital Systems v02r02. Mobile and portable (hand-held) stations operating are limited to average ERP of 3 watts with LTE band17 . average ERP of 7 watts with LTE band 5.

Equivalent isotropic radiated power output measurements by substitution method according to ANSI /TIA / EIA-603-C, and the spectrum analyzer configuration follows KDB 971168 D01 Power Meas. License Digital Systems v02r02. Mobile and portable (hand-held) stations operating are limited to average EIRP of 2 watts with LTE band 2 / 7 and 1 watt with LTE band 4.

5.1.2 TEST SETUP

The procedure of radiated spurious emissions is as follows:

a) Pre-calibration With pre-calibration method, the Radiated Spurious Emissions(RSE) is calculated as, $RSE = R_x(\text{ dBuV }) + CL(\text{ dB }) + SA(\text{ dB }) + \text{Gain}(\text{ dBi }) - 107(\text{ dBuV to dBm })$ The SA is calibrated using following setup.

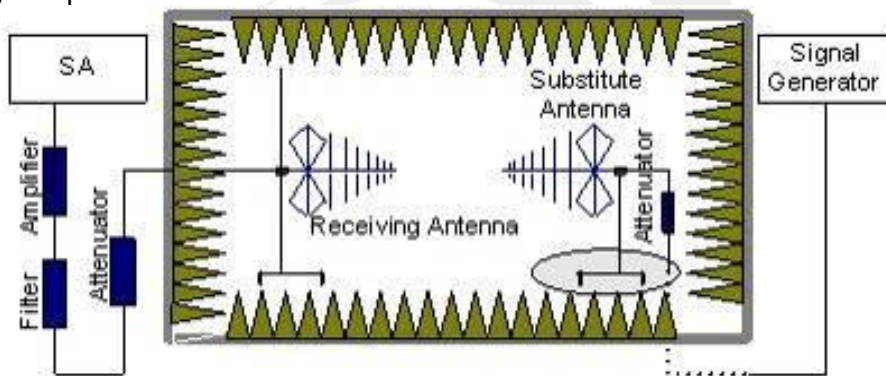

b) EUT was placed on a 1.5 meter high non-conductive stand at a 3 meter test distance from the receive antenna. A receiving antenna was placed on the antenna mast 3 meters from the test item for emission measurements. The height of receiving antenna is 0.8m. The test setup refers to figure below. Detected emissions were maximized at each frequency by rotating the test item and adjusting the receiving antenna polarization. The radiated emission measurements of all non-harmonic and harmonics of the transmit frequency through the 10th harmonic were measured with peak detector and 1MHz bandwidth.

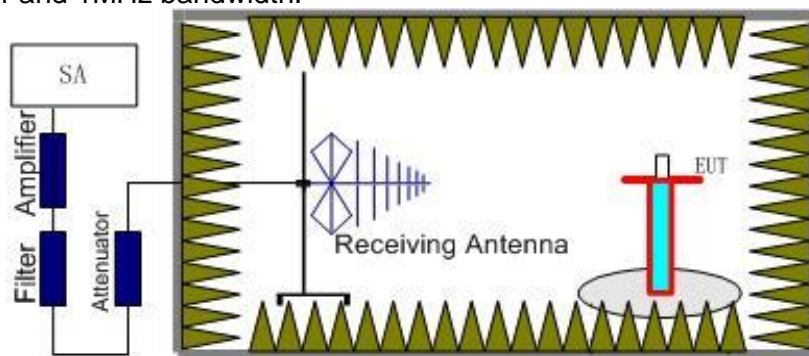



Radiated emissions measurements were made only at the upper, middle, and lower carrier frequencies. It was decided that measurements at these three carrier frequencies would be sufficient to demonstrate compliance with emissions limits because it was seen that all the significant spurs occur well outside the band and no radiation was seen from a carrier in one block of any band into any of the other blocks.

The substitution method is used. Substitution values at each frequency are measured before and saved to the test software. A "reference path loss" is established and the ARpl is the attenuation of "reference path loss", and including the gain of receive antenna, the gain of the preamplifier, the cable loss and the air loss. The measurement results are obtained as described below: $Power = P_{Mea} + AR_{pl}$

5.1.3 TEST PROCEDURES

1. The testing follows FCC KDB 971168 v02r02 Section 5.6. and ANSI / TIA-603-C-2009 Section 2.2.17.
2. The EUT was placed on a non-conductive rotating platform 1.5 meters high in a semi-anechoic chamber. The radiated emission at the fundamental frequency was measured at 3 m with a test antenna and a spectrum analyzer with Peak detector.
3. During the measurement, the system simulator parameters were set to force the EUT transmitting at maximum output power. The maximum emission was recorded from analyzer power level (LVL) from the 360 degrees rotation of the turntable and the test antenna raised and lowered over a range from 1 to 4 meters in both horizontally and vertically polarized orientations.
4. Effective Isotropic Radiated Power (EIRP) was measured by substitution method according to TIA/EIA-603-C. The EUT was replaced by dipole antenna (substitution antenna) at same location, and then a known power from S.G. was applied into the dipole antenna through a Tx cable, and then recorded the maximum Analyzer reading through raised and lowered the test antenna. The correction factor (in dB) = S.G. - Tx Cable loss + Substitution antenna gain - Analyzer reading. Then the EUT's EIRP was calculated with the correction factor, $EIRP = LVL + \text{Correction factor}$ and $ERP = EIRP - 2.15$.
5. RB Set greater than bandwidth, Vb Set spectrum analyzer Maximum support.



5.1.4 TEST RESULTS

LTE Band 2

LTE Band 2 / 1.4MHz					
Channel	Modulation	RB		Horizontal	Vertical
		Size	Offset	EIRP(dBm)	EIRP(dBm)
Lowest	QPSK	1	0	20.76	20.79
Middle		1	0	20.56	20.74
Highest		1	0	20.87	20.82
Lowest	16QAM	1	0	19.97	19.89
Middle		1	0	19.84	19.83
Highest		1	0	19.75	19.72
Limit	EIRP<2W=33dBm			Result	PASS

LTE Band 2 / 3MHz					
Channel	Modulation	RB		Horizontal	Vertical
		Size	Offset	EIRP(dBm)	EIRP(dBm)
Lowest	QPSK	1	0	20.56	20.76
Middle		1	0	20.59	20.57
Highest		1	0	20.85	20.92
Lowest	16QAM	1	0	19.74	19.44
Middle		1	0	19.89	19.87
Highest		1	0	19.63	19.56
Limit	EIRP<2W=33dBm			Result	PASS

LTE Band 2 / 5MHz					
Channel	Modulation	RB		Horizontal	Vertical
		Size	Offset	EIRP(dBm)	EIRP(dBm)
Lowest	QPSK	1	0	20.63	20.67
Middle		1	0	20.65	20.59
Highest		1	0	20.71	20.62
Lowest	16QAM	1	0	19.79	19.49
Middle		1	0	19.84	19.83
Highest		1	0	19.54	19.56
Limit	EIRP<2W=33dBm			Result	PASS



LTE Band 2 / 10MHz					
Channel	Modulation	RB		Horizontal	Vertical
		Size	Offset	EIRP(dBm)	EIRP(dBm)
Lowest	QPSK	1	0	20.69	20.67
Middle		1	0	20.86	20.59
Highest		1	0	20.75	20.49
Lowest	16QAM	1	0	19.74	19.74
Middle		1	0	19.93	19.91
Highest		1	0	19.92	19.82
Limit	EIRP<2W=33dBm			Result	PASS

LTE Band 2 / 15MHz					
Channel	Modulation	RB		Horizontal	Vertical
		Size	Offset	EIRP(dBm)	EIRP(dBm)
Lowest	QPSK	1	0	20.52	20.79
Middle		1	0	20.73	20.69
Highest		1	0	20.67	20.67
Lowest	16QAM	1	0	19.76	19.73
Middle		1	0	19.86	19.87
Highest		1	0	19.92	19.84
Limit	EIRP<2W=33dBm			Result	PASS

LTE Band 2 / 20MHz					
Channel	Modulation	RB		Horizontal	Vertical
		Size	Offset	EIRP(dBm)	EIRP(dBm)
Lowest	QPSK	1	0	20.45	20.66
Middle		1	0	20.69	20.54
Highest		1	0	20.79	20.52
Lowest	16QAM	1	0	19.72	19.74
Middle		1	0	19.85	19.86
Highest		1	0	19.91	19.72
Limit	EIRP<2W=33dBm			Result	PASS



LTE Band 4

LTE Band 4 / 1.4MHz					
Channel	Modulation	RB		Horizontal	Vertical
		Size	Offset	EIRP(dBm)	EIRP(dBm)
Lowest	QPSK	1	0	22.43	22.69
Middle		1	0	22.67	22.75
Highest		1	0	22.96	22.79
Lowest	16QAM	1	0	21.79	21.71
Middle		1	0	21.65	21.83
Highest		1	0	21.92	21.84
Limit	EIRP<1W=30dBm			Result	PASS

LTE Band 4 / 3MHz					
Channel	Modulation	RB		Horizontal	Vertical
		Size	Offset	EIRP(dBm)	EIRP(dBm)
Lowest	QPSK	1	0	22.36	22.19
Middle		1	0	22.61	22.56
Highest		1	0	22.77	22.74
Lowest	16QAM	1	0	21.74	21.73
Middle		1	0	21.69	21.89
Highest		1	0	21.95	21.65
Limit	EIRP<1W=30dBm			Result	PASS

LTE Band 4 / 5MHz					
Channel	Modulation	RB		Horizontal	Vertical
		Size	Offset	EIRP(dBm)	EIRP(dBm)
Lowest	QPSK	1	0	22.47	22.28
Middle		1	0	22.11	22.15
Highest		1	0	22.74	22.65
Lowest	16QAM	1	0	21.69	21.79
Middle		1	0	21.85	21.84
Highest		1	0	21.63	21.72
Limit	EIRP<1W=30dBm			Result	PASS



LTE Band 4 / 10MHz					
Channel	Modulation	RB		Horizontal	Vertical
		Size	Offset	EIRP(dBm)	EIRP(dBm)
Lowest	QPSK	1	0	22.11	22.23
Middle		1	0	22.27	22.19
Highest		1	0	22.37	22.59
Lowest	16QAM	1	0	21.82	21.63
Middle		1	0	21.64	21.19
Highest		1	0	21.82	21.76
Limit	EIRP<1W=30dBm			Result	PASS

LTE Band 4 / 15MHz					
Channel	Modulation	RB		Horizontal	Vertical
		Size	Offset	EIRP(dBm)	EIRP(dBm)
Lowest	QPSK	1	0	22.47	22.15
Middle		1	0	22.14	22.26
Highest		1	0	22.15	22.16
Lowest	16QAM	1	0	21.27	21.22
Middle		1	0	21.56	21.62
Highest		1	0	21.13	21.19
Limit	EIRP<1W=30dBm			Result	PASS

LTE Band 4 / 20MHz					
Channel	Modulation	RB		Horizontal	Vertical
		Size	Offset	EIRP(dBm)	EIRP(dBm)
Lowest	QPSK	1	0	22.71	22.76
Middle		1	0	22.34	22.32
Highest		1	0	22.39	22.36
Lowest	16QAM	1	0	21.09	21.15
Middle		1	0	21.11	21.15
Highest		1	0	21.27	21.36
Limit	EIRP<1W=30dBm			Result	PASS



LTE Band 17

LTE Band 17 / 5MHz					
Channel	Modulation	RB		Horizontal	Vertical
		Size	Offset	EIRP(dBm)	EIRP(dBm)
Lowest	QPSK	1	0	23.57	23.64
Middle		1	0	23.21	23.59
Highest		1	0	23.36	23.27
Lowest	16QAM	1	0	22.37	22.32
Middle		1	0	22.29	22.19
Highest		1	0	22.42	22.31
Limit	ERP<3W=34.77dBm			Result	PASS

LTE Band 17 / 10MHz					
Channel	Modulation	RB		Horizontal	Vertical
		Size	Offset	EIRP(dBm)	EIRP(dBm)
Lowest	QPSK	1	0	23.51	23.28
Middle		1	0	23.59	23.37
Highest		1	0	22.42	22.35
Lowest	16QAM	1	0	23.21	23.46
Middle		1	0	23.29	23.37
Highest		1	0	22.29	22.25
Limit	ERP<3W=34.77dBm			Result	PASS

6. OCCUPIED BANDWIDTH

6.1 DESCRIPTION OF OCCUPIED BANDWIDTH MEASUREMENT

6.1.1 MEASUREMENT METHOD

1.The occupied bandwidth is the width of a frequency band such that, below the lower and above the upper frequency limits, the mean powers emitted are each equal to a specified percentage 0.5% of the total mean transmitted power.

2.The 26 db emission bandwidth is defined as the frequency range between two points, one above and one below the carrier frequency, at which the spectral density of the emission is attenuated 26 db below the maximum in-band spectral density of the modulated signal. spectral density (power per unit bandwidth) is to be measured with a detector of resolution bandwidth equal to approximately 1.0% of the emission bandwidth.

6.1.2 TEST SETUP

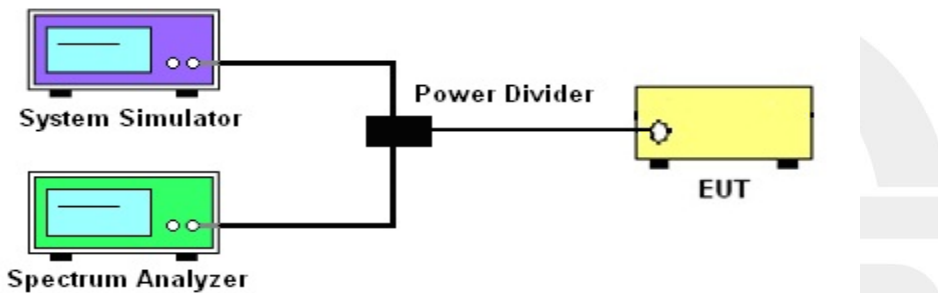

6.1.3 TEST PROCEDURES

1. The testing follows FCC KDB 971168 v02r02 Section 4.1.and 4.2
2. The EUT was connected to spectrum and system simulator via a power divider
3. Select lowest, middle, and highest channels for each band and different modulation.
4. Set the test probe and measure the Occupied Bandwidth of the spectrum analyzer
5. Measure and record the Occupied Bandwidth from the Spectrum Analyzer.

	LTE					
LTE BW	1.4M	3M	5M	10M	15M	20M
Span	3MHz	6MHz	10MHz	20MHz	30MHz	40MHz
RBW	30kHz	100kHz	100kHz	300kHz	300kHz	300kHz
VBW	100kHz	300kHz	300kHz	1000kHz	1000kHz	1000kHz
Detector	PK	PK	PK	PK	PK	PK
Trace	Max	Max	Max	Max	Max	Max
Sweep Count	Auto	Auto	Auto	Auto	Auto	Auto



6.1.4 MEASUREMENT RESULT

LTE BAND 2

LTE Band 2 Bandwidth [MHz]							
BW [MHz]	Mod	Lowest		Middle		Highest	
		26dB BW	99% BW	26dB BW	99% BW	26dB BW	99% BW
1.4	QPSK	1.284	1.099	1.269	1.108	1.270	1.099
1.4	16-QAM	1.278	1.099	1.269	1.099	1.289	1.101
3	QPSK	2.918	2.685	2.902	2.691	2.911	2.684
3	16-QAM	2.930	2.684	2.906	2.691	2.907	2.682
5	QPSK	4.938	4.488	4.990	4.492	4.913	4.488
5	16-QAM	4.967	4.487	4.982	4.487	4.925	4.489
10	QPSK	9.794	8.960	9.720	8.946	9.704	8.949
10	16-QAM	9.763	8.958	9.723	8.954	9.704	8.946
15	QPSK	14.700	13.434	14.600	13.422	14.630	13.432
15	16-QAM	14.700	13.434	14.620	13.423	14.630	13.433
20	QPSK	19.220	17.908	19.190	17.879	19.140	17.892
20	16-QAM	19.300	17.917	19.220	17.912	19.200	17.908

LTE BAND 4

LTE Band 4 Bandwidth [MHz]							
BW [MHz]	Mod	Lowest		Middle		Highest	
		26dB BW	99% BW	26dB BW	99% BW	26dB BW	99% BW
1.4	QPSK	1.296	1.101	1.274	1.103	1.284	1.104
1.4	16-QAM	1.262	1.100	1.276	1.108	1.284	1.104
3	QPSK	2.911	2.685	2.924	2.684	2.918	2.685
3	16-QAM	2.917	2.686	2.921	2.684	2.919	2.685
5	QPSK	4.965	4.492	4.980	4.486	4.956	4.487
5	16-QAM	4.969	4.484	4.992	4.487	4.966	4.482
10	QPSK	9.696	8.961	9.720	8.941	9.780	8.956
10	16-QAM	9.852	8.965	9.746	8.952	9.785	8.956
15	QPSK	14.650	13.456	14.610	13.407	14.670	13.431
15	16-QAM	14.610	13.444	14.570	13.402	14.540	13.432
20	QPSK	19.130	17.943	19.080	17.878	19.410	17.903
20	16-QAM	19.350	17.953	19.370	17.897	19.160	17.893



LTE BAND 17

LTE Band XVII Bandwidth [MHz]							
BW [MHz]	Mod	Lowest		Middle		Highest	
		26dB BW	99% BW	26dB BW	99% BW	26dB BW	99% BW
5	QPSK	4.995	4.495	4.956	4.483	4.911	4.494
5	16-QAM	5.005	4.494	4.936	4.487	4.902	4.494
10	QPSK	9.774	8.972	9.685	8.950	9.819	8.967
10	16-QAM	9.775	8.972	9.757	8.954	9.824	8.969





LTE band 2

LTE band 2 (99% and -26 Bandwidth)





LTE band 2

LTE band 2 (99% and -26 Bandwidth)

Lowest Channel / 3MHz / QPSK

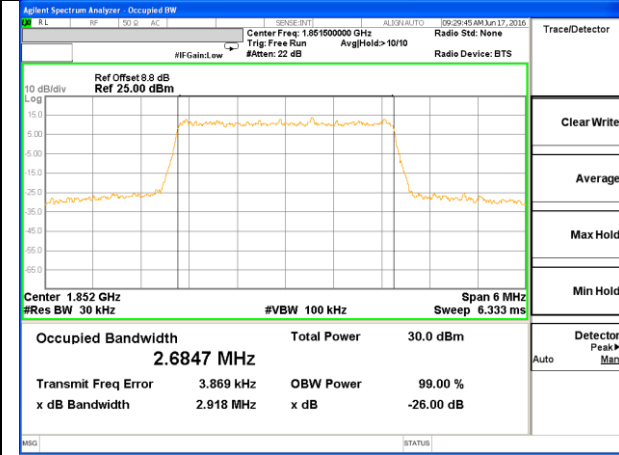

Lowest Channel / 3MHz / 16QAM

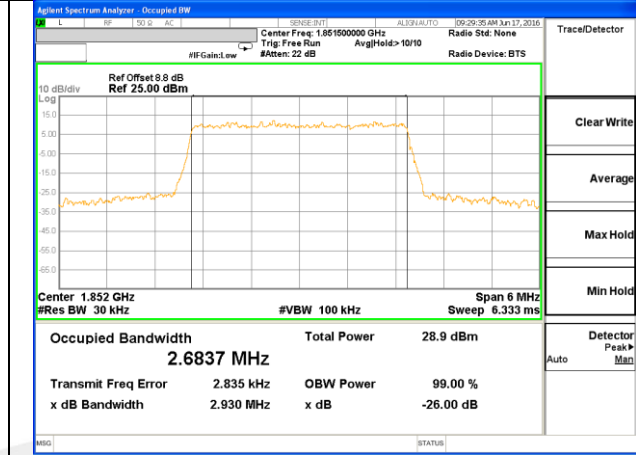

Middle Channel / 3MHz / QPSK

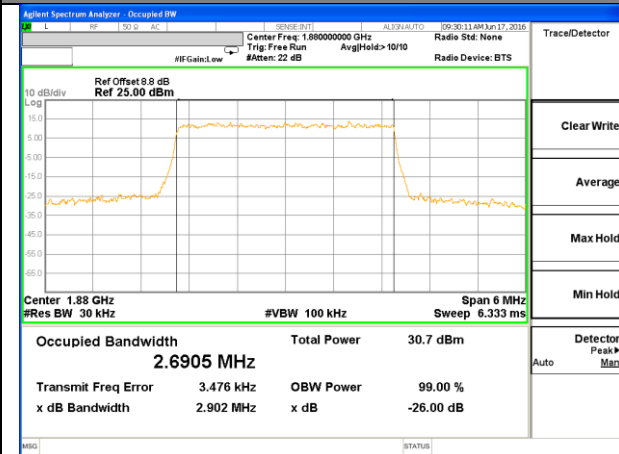

Middle Channel / 3MHz / 16QAM

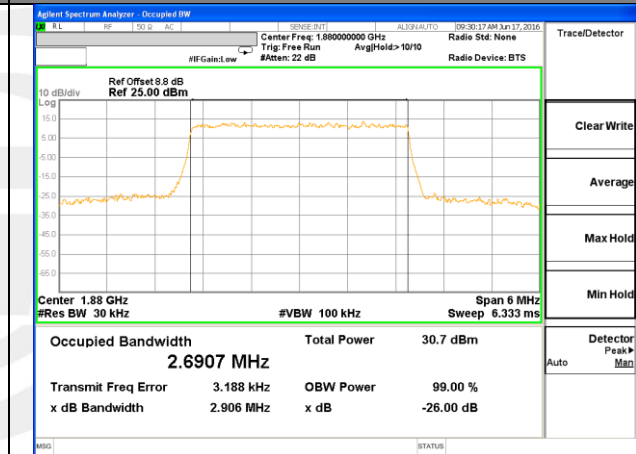

Highest Channel / 3MHz / QPSK

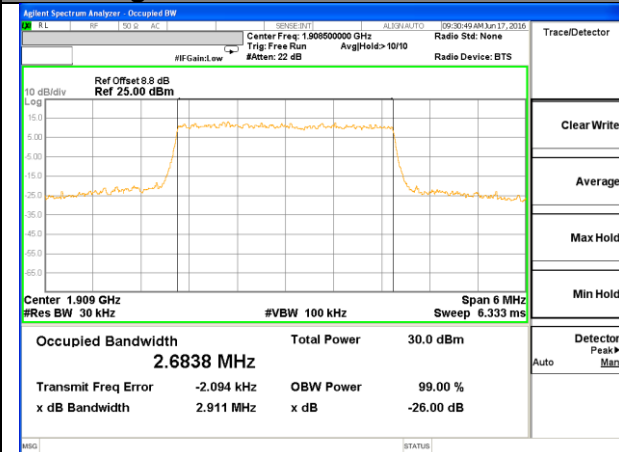

Highest Channel / 3MHz / 16QAM

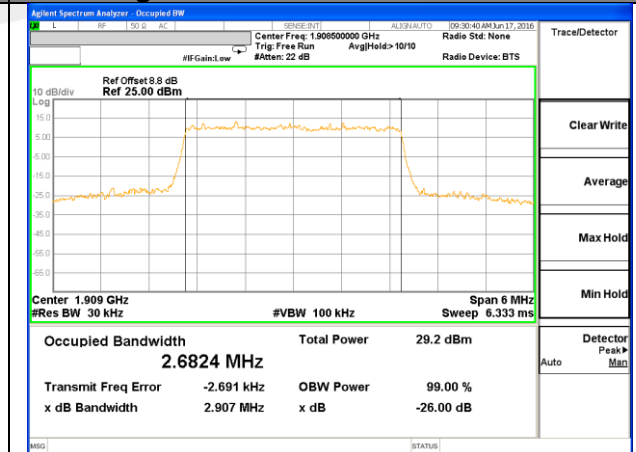



LTE band 2

LTE band 2 (99% and -26 Bandwidth)





LTE band 2

LTE band 2 (99% and -26 Bandwidth)





LTE band 2

LTE band 2 (99% and -26 Bandwidth)

Lowest Channel / 15MHz / QPSK

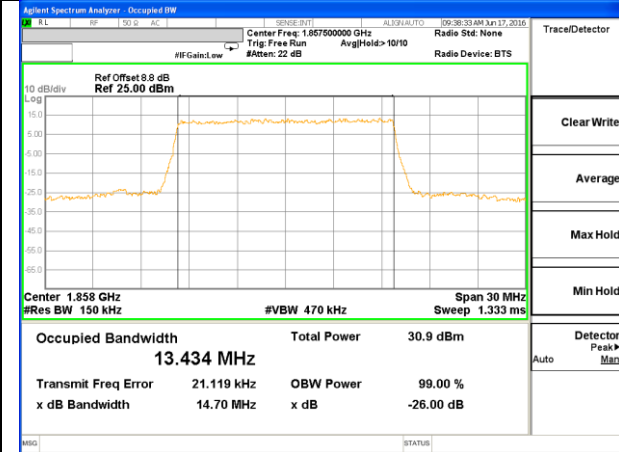

Lowest Channel / 15MHz / 16QAM

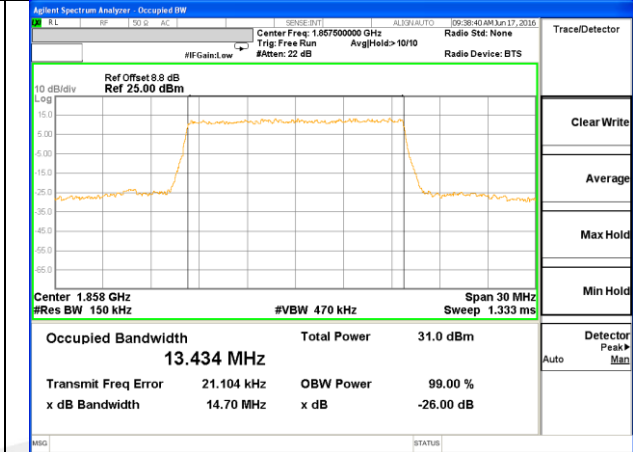

Middle Channel / 15MHz / QPSK

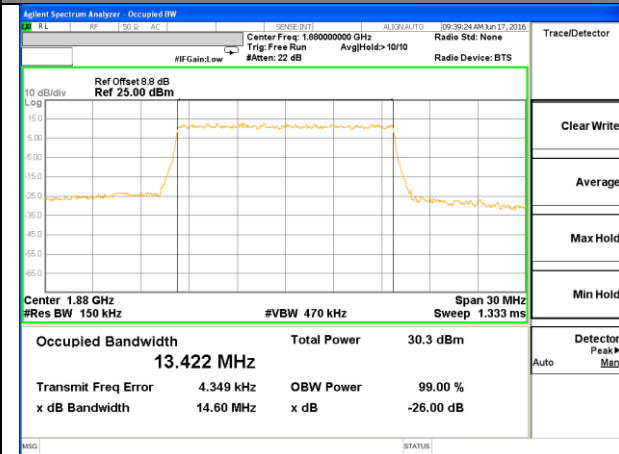

Middle Channel / 15MHz / 16QAM

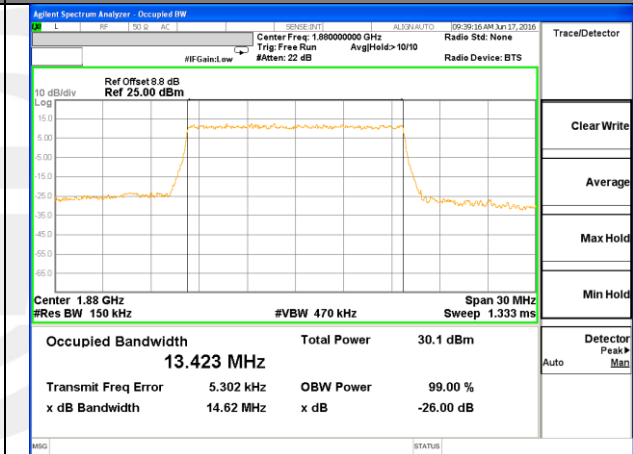

Highest Channel / 15MHz / QPSK

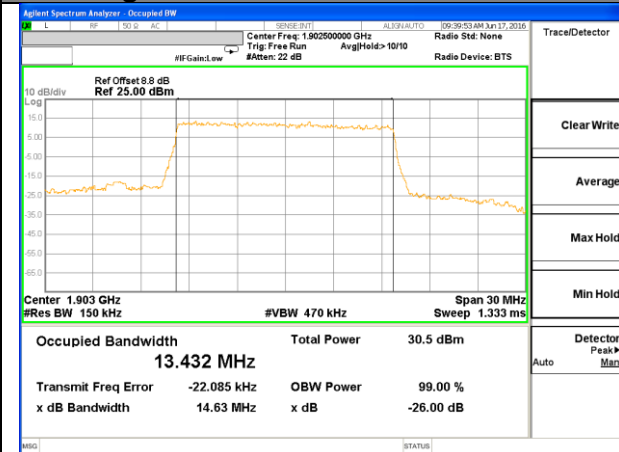

Highest Channel / 15MHz / 16QAM

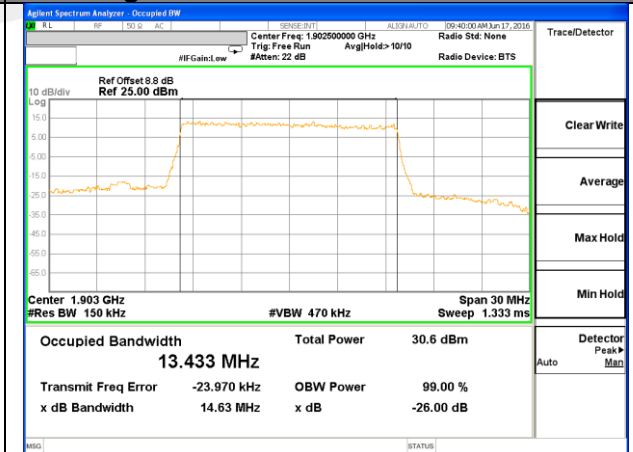



LTE band 2

LTE band 2 (99% and -26 Bandwidth)

Lowest Channel / 20MHz / QPSK

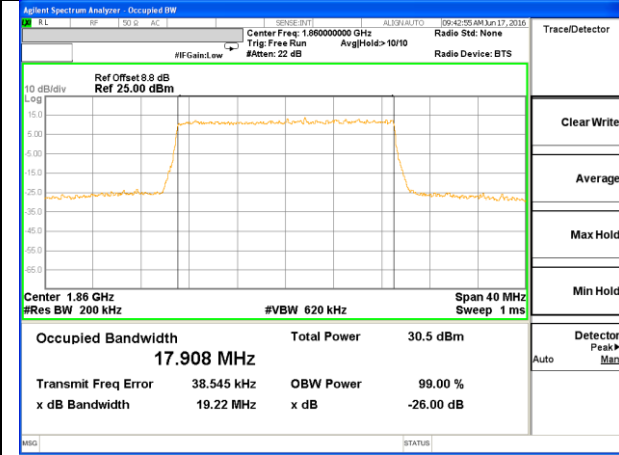

Lowest Channel / 20MHz / 16QAM

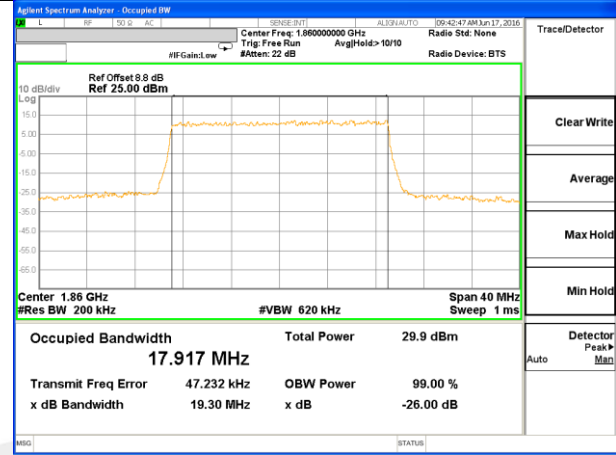

Middle Channel / 20MHz / QPSK

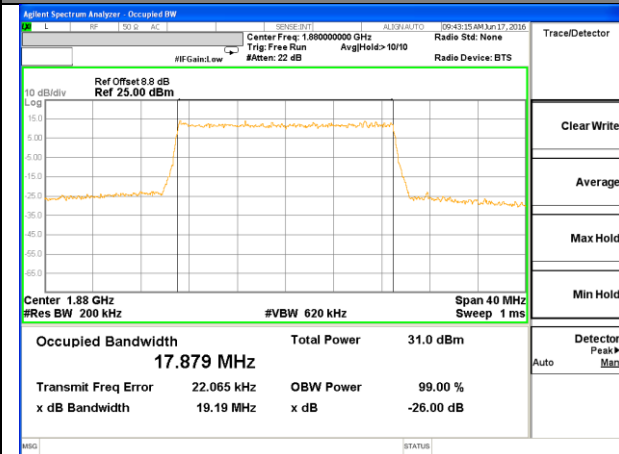

Middle Channel / 20MHz / 16QAM

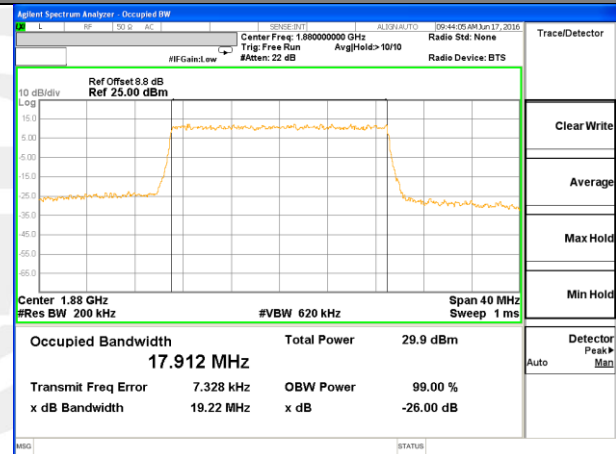

Highest Channel / 20MHz / QPSK

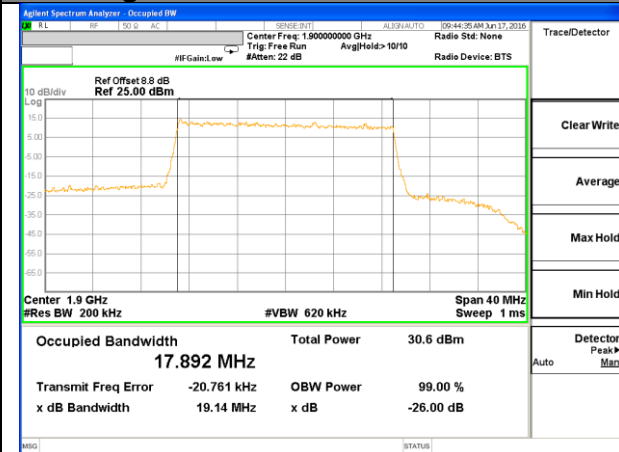

Highest Channel / 20MHz / 16QAM

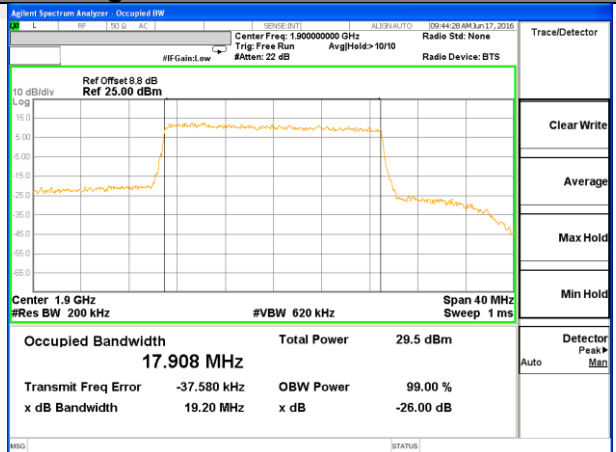



LTE band 4

LTE band 4 (99% and -26 Bandwidth)

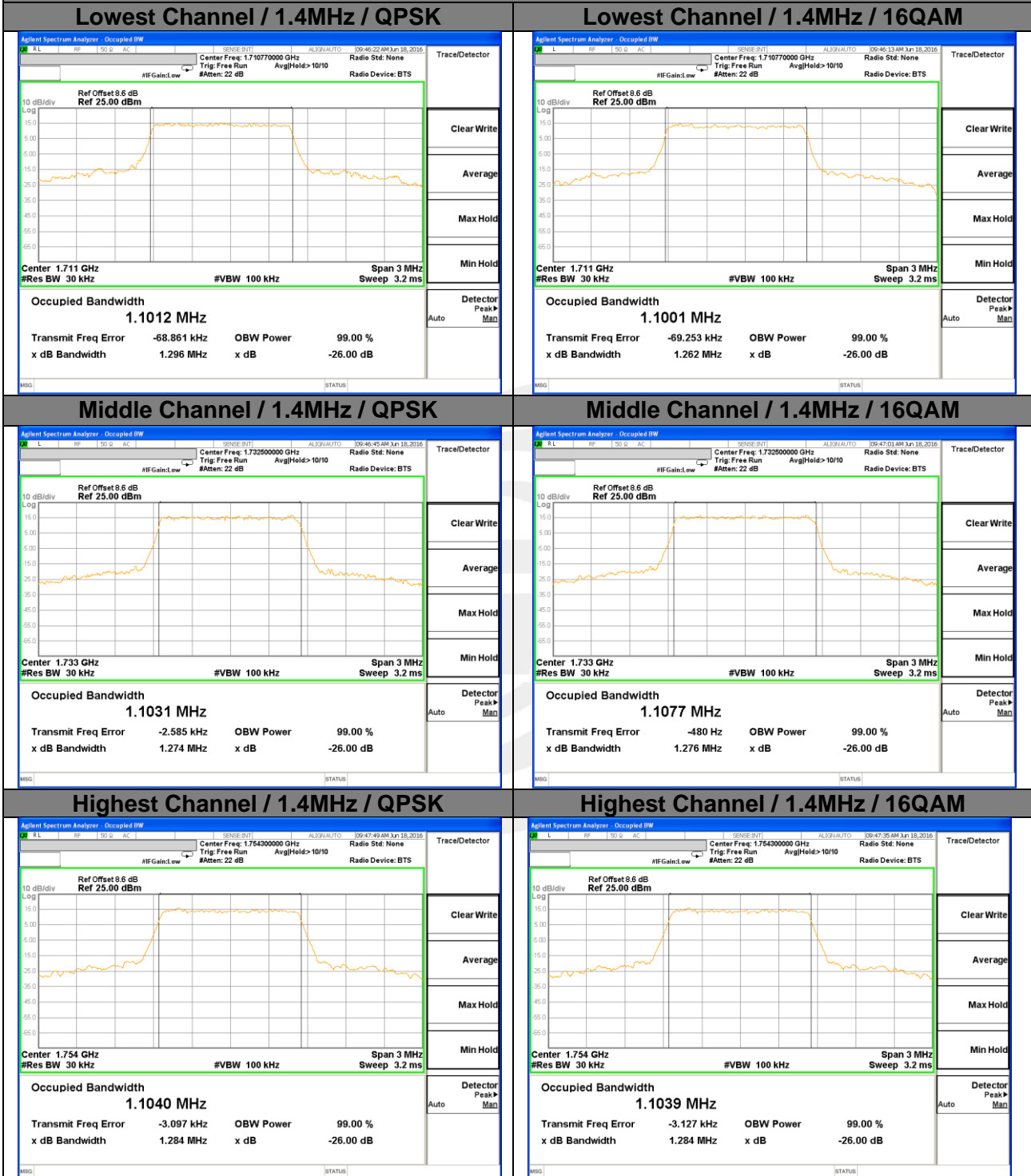



LTE band 4

LTE band 4 (99% and -26 Bandwidth)

Lowest Channel / 3MHz / QPSK

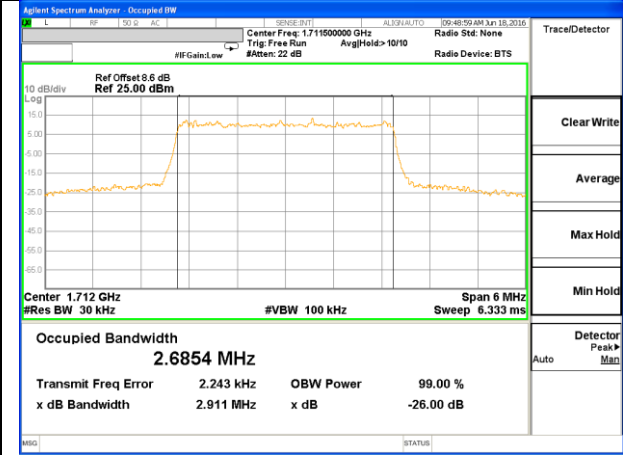

Lowest Channel / 3MHz / 16QAM

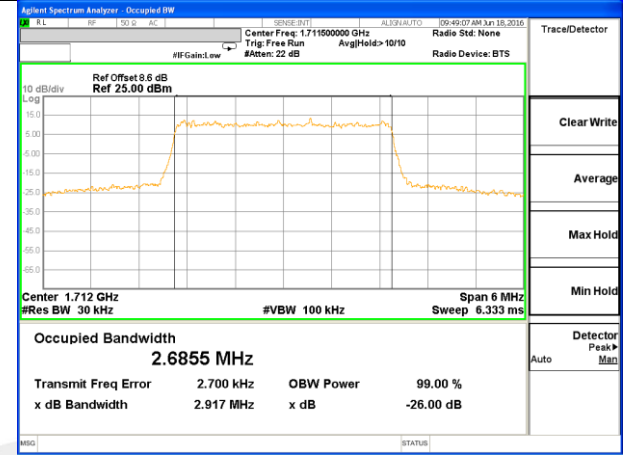

Middle Channel / 3MHz / QPSK

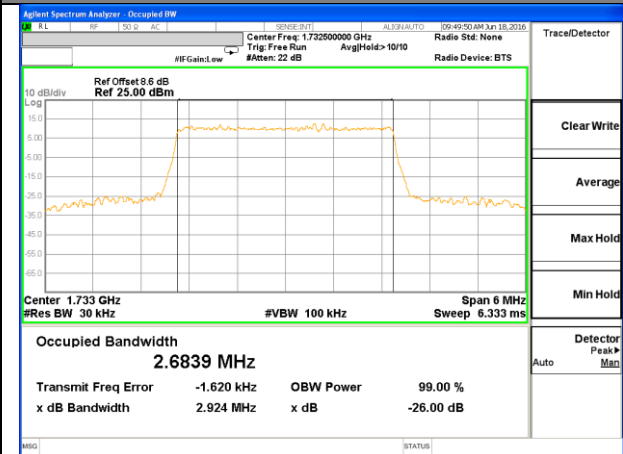

Middle Channel / 3MHz / 16QAM

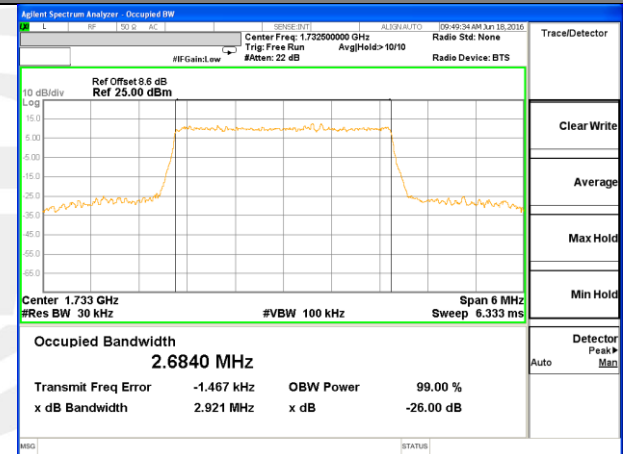

Highest Channel / 3MHz / QPSK

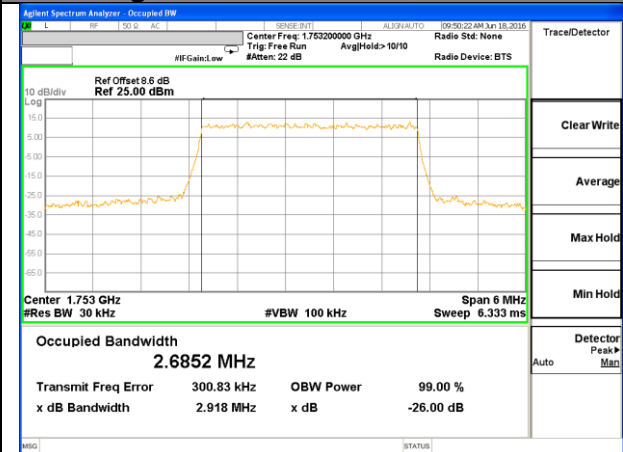

Highest Channel / 3MHz / 16QAM

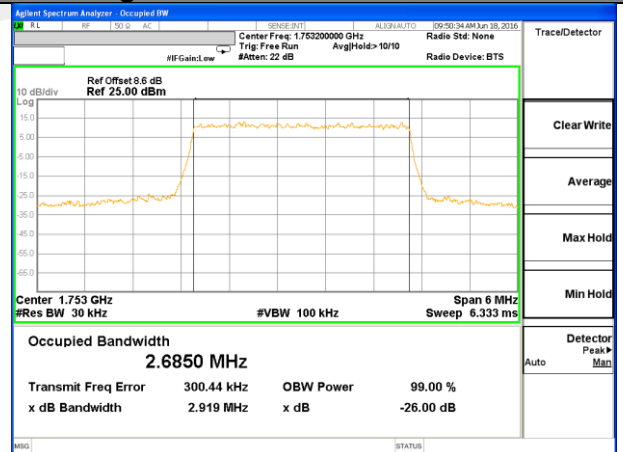



LTE band 4

LTE band 4 (99% and -26 Bandwidth)





LTE band 4

LTE band 4 (99% and -26 Bandwidth)

Lowest Channel / 10MHz / QPSK

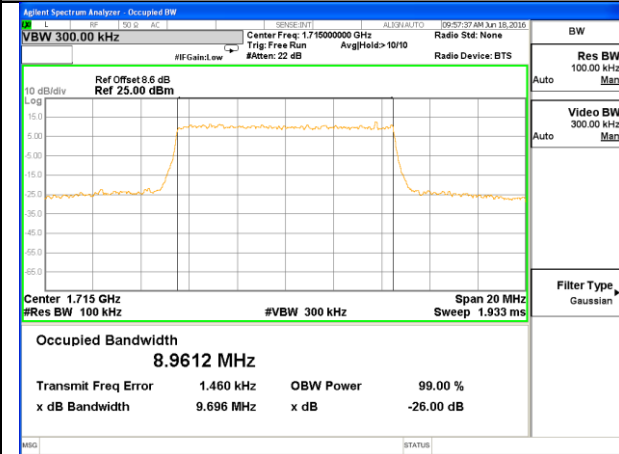

Lowest Channel / 10MHz / 16QAM

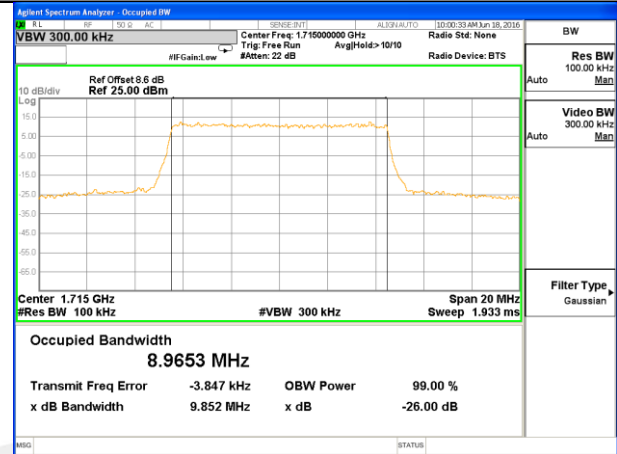

Middle Channel / 10MHz / QPSK

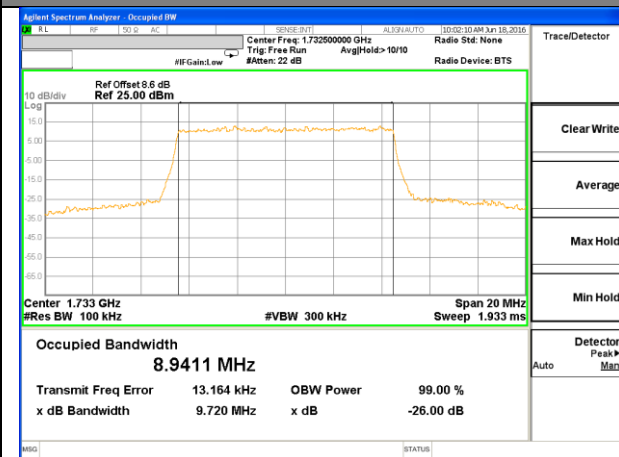

Middle Channel / 10MHz / 16QAM

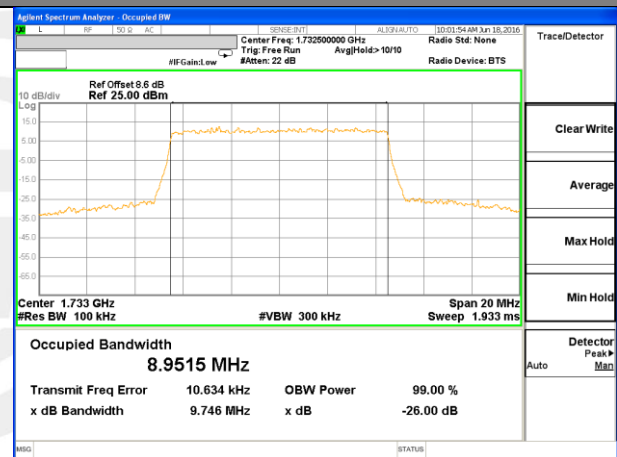

Highest Channel / 10MHz / QPSK

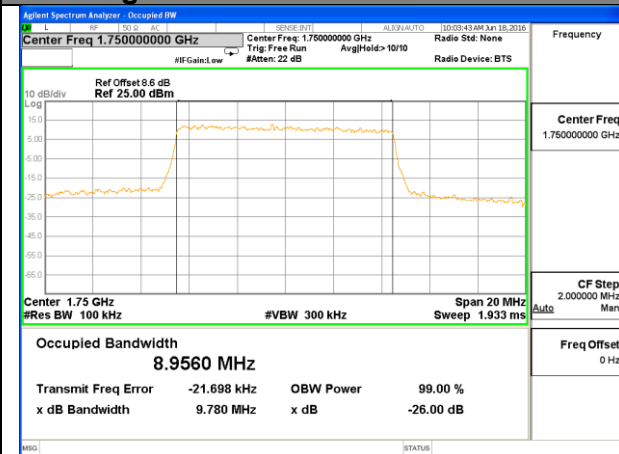

Highest Channel / 10MHz / 16QAM

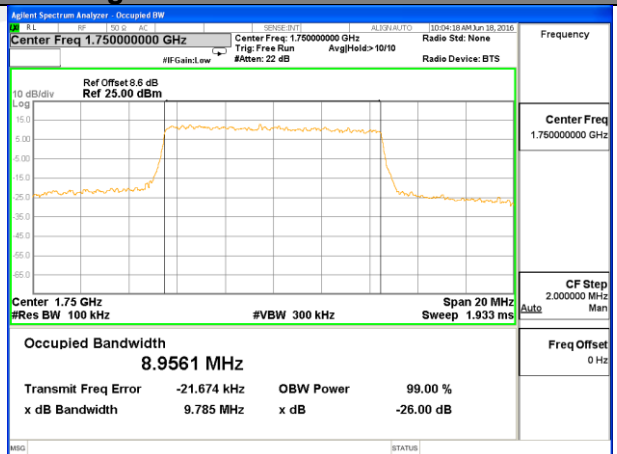



LTE band 4

LTE band 4 (99% and -26 Bandwidth)





LTE band 4

LTE band 4 (99% and -26 Bandwidth)

Lowest Channel / 20MHz / QPSK

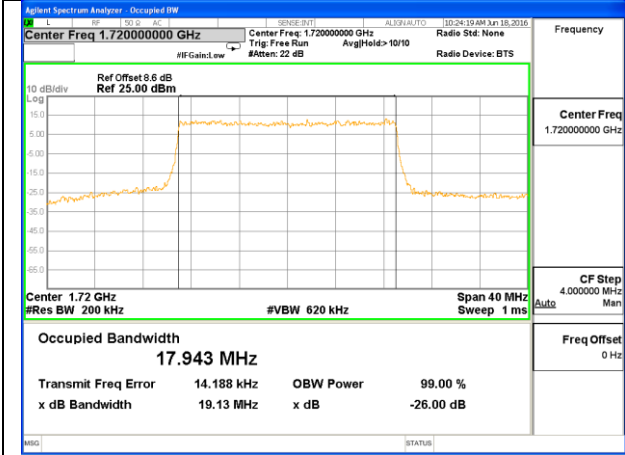

Lowest Channel / 20MHz / 16QAM

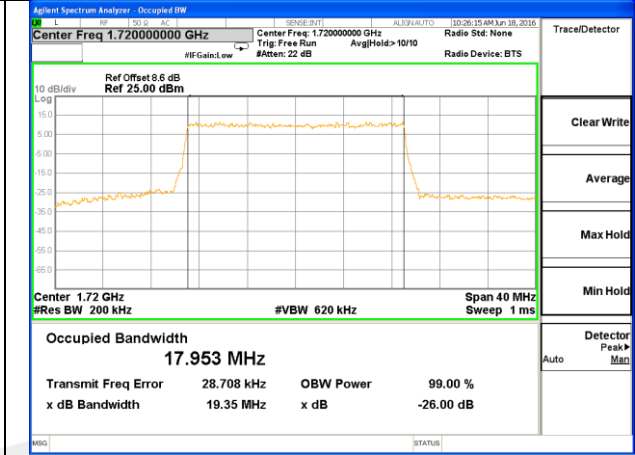

Middle Channel / 20MHz / QPSK

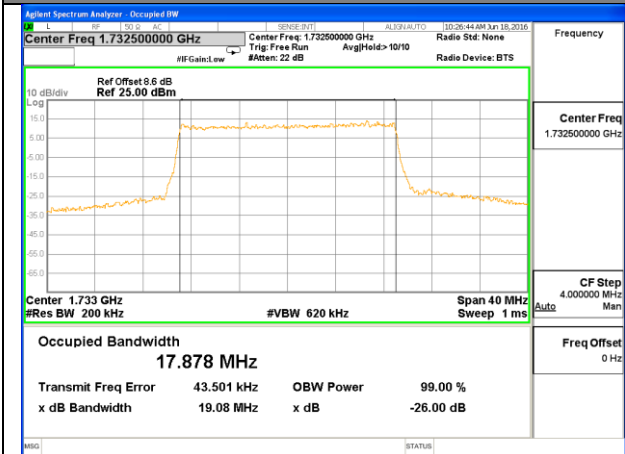

Middle Channel / 20MHz / 16QAM

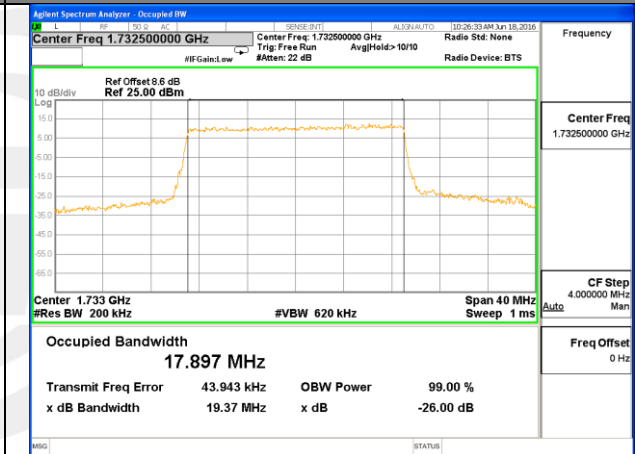

Highest Channel / 20MHz / QPSK

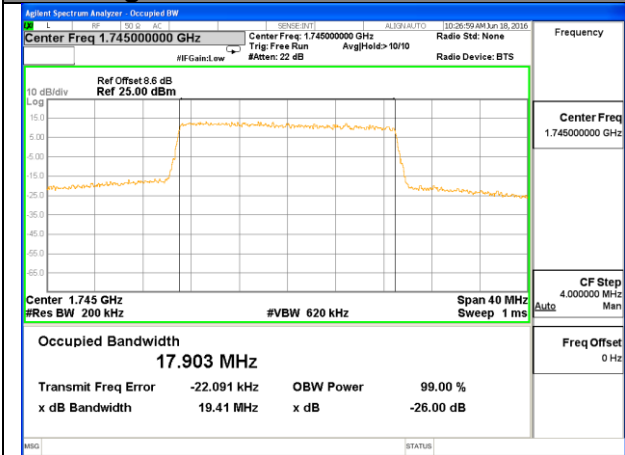

Highest Channel / 20MHz / 16QAM

