

Robot vacuum cleaner

M6S

User Manual

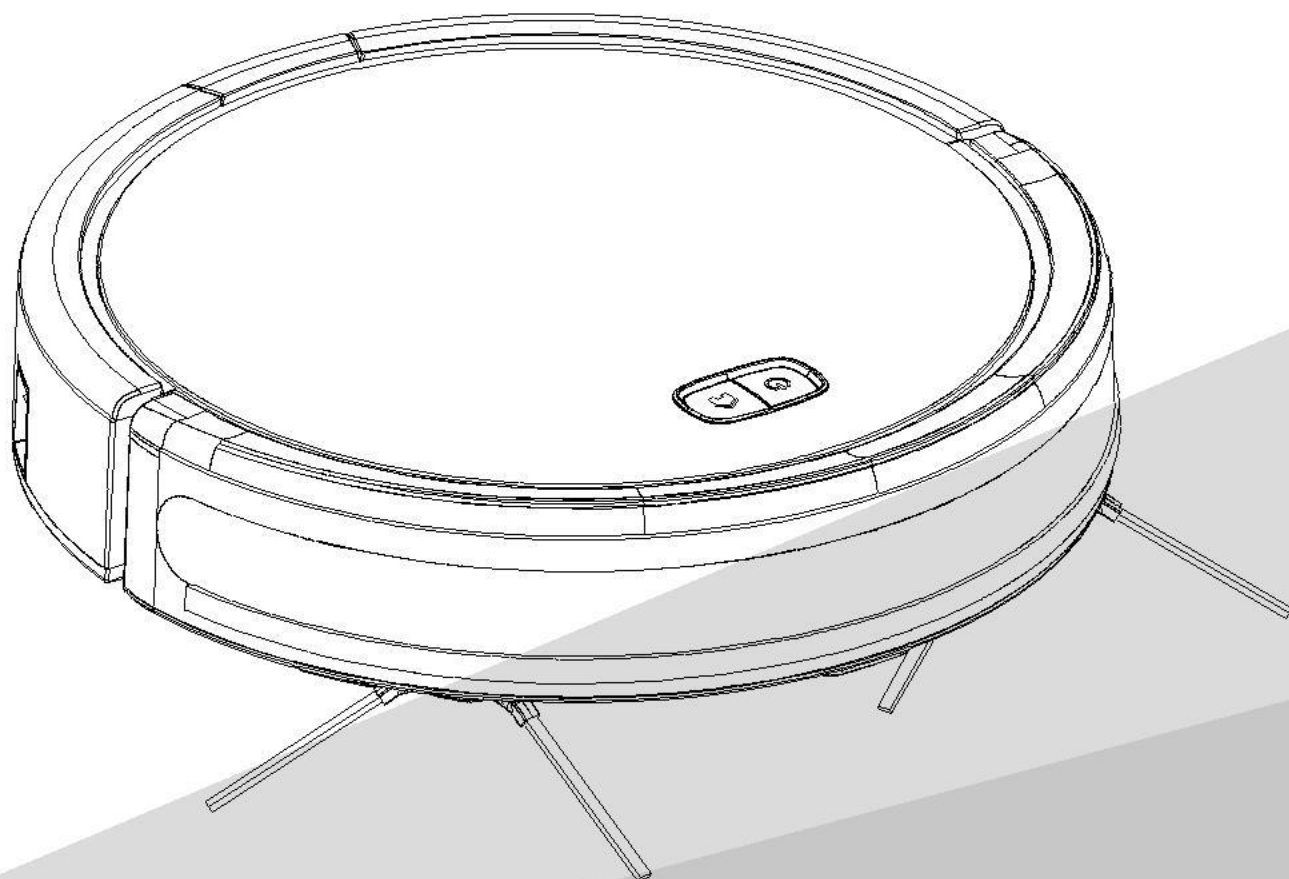

Thank you for purchasing this product.

Please read the user guide carefully before use.

Thank you for purchasing the M6S Robot vacuum cleaner. I hope you will enjoy it!

If you have any questions about the product during use, please call our service hotline.

Hotline: 4006-788-228

Table of Contents

1. Safety Instructions.....	2-4	5. Product Maintenance.....	11-14
1.1 Instructions for use		5.1 Clean the charging pole pieces	
1.2 Safety precautions		5.2 Clean the dust box	
1.3 About child safety		5.3 Clean the middle sweeper	
1.4 About the batteries		5.4 Clean the side brush	
1.5 Scope of use of the product		5.5 Clean the wheels	
1.6 Disclaimers		5.6 Clean the sensor	
2. Product Composition.....	5-6		
2.1 Host machine and accessories of the product			
2.2 Names of parts			
3. Product Installation.....	7	6. Troubleshooting.....	15
4. Product Use.....	8-10	7. Technical Parameters.....	16
4.1 Use of the host machine			
4.2 Charging method			
4.3 Use of the remote controller (optional)			
4.4 APP Operation Guide (optional)			
4.5 Instructions for Use of Wet Mop Assembly (optional)			
4.6 Instructions for Using Virtual Magnetic Stripe Wall (optional)			

1. Safety Instructions

1.1 Instructions for use



Please pay attention to the following basic safety precautions before using the product:

- * Read the user manual carefully and follow the instructions in the user annual when using the product.
- * Keep the user manual well for future reference.
- * If you need to transfer the product to a third party, please attach the user manual along with the product.
- * Any operation not in conformity to the instructions in the user manual may result in serious personal injury or damage to the product itself.

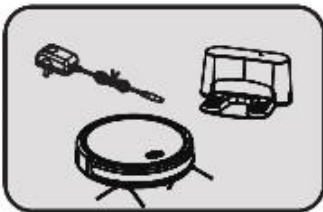

1.2 Safety precautions

Warning





-  This product can only use the adapter, batteries and charging dock that are provided with this product. Failure to do so may result in damage to the product, electrical shock, or fire caused by high voltage.
-  Do not use this product if the host machine and accessories of this product are found to be damaged. Contact our after-sales service department. Except for the service technicians designated or authorized by our company, no one may disassemble, repair or modify this product.



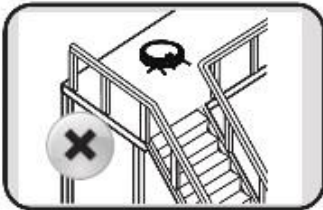

-  Unplug the product before maintenance.
-  Do not touch the power plug or the product when your hands are wet, as this may result in electrical shock.
-  If the power cord is damaged, it must be replaced by the manufacturer, its service department or a similar professional to avoid danger.



-  To prevent the product from falling accidentally, do not use this product in a suspended place without a protective fence, which may result in personal injury.
-  The user shall not replace the batteries privately.



-  Prevent clothing or any part of your body (hair, fingers, etc.) from getting caught in the brush or wheel of the vacuum cleaner. Failure to do so may result in personal injury.
-  Do not place the product near fire or flammable/explosive/corrosive materials.
-  If the user manual is missing, please contact your local dealer or call the after-sales service department to obtain an electronic user manual.

! Caution

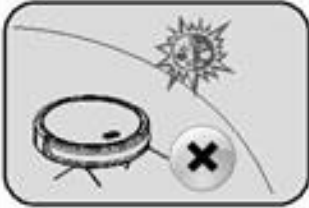

This product can only be used indoors.

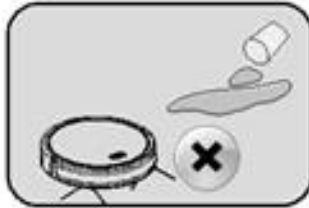

Prevent the suction of water, oil or other liquids, which may damage the vacuum cleaner.

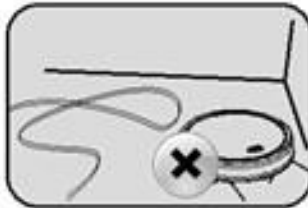

Arrange scattered wires on the floor before use for fear of affecting the normal operation of the vacuum cleaner.



Remove fragile objects before use.

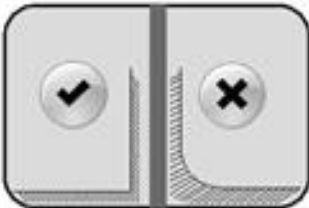

The charging dock shall be placed against the wall and on a flat floor for fear of affecting product functionality.



Unplug the charging dock if it remains unused for a long time.



When the product is working, removal of the charging dock will affect the normal recharging of the machine.



Do not use this product to suck in sharp objects (e.g. shattered glass and nails) for fear of damage to the product.



Do not use this product in a wet, flammable, explosive or corrosive environment.

1.3 About child safety



* Children under the age of 8 are not allowed to use this product. Persons with physical, sensory or intellectual disabilities or lack of relevant experience/knowledge cannot use the machine unless under supervision, operating instructions or awareness of the danger. Children are not allowed to play with the machine or clean/repair the machine unless under supervision.

* Children are not allowed to play with the product's packaging bag for fear of suffocation.

1.4 About the batteries



1. Only the batteries provided by the manufacturer are applicable to the product.
2. The batteries shall be removed when the product is discarded.
3. If you need to replace the battery of the host machine, please contact our after-sales service department. Use of wrong batteries may cause a safety accident.
4. If the batteries leak, prevent the contact of the liquid with the skin or clothing. Immediately wipe it with a dry cloth and send it to the recycling station or designated maintenance point. Do not discard it.
5. Please properly dispose of the old batteries of the product. The batteries contain hazardous substances harmful to the environment. Please follow the local environmental regulations and send them to the designated recycling site.

- non-rechargeable batteries are not to be recharged;
- different types of batteries or new and used batteries are not to be mixed;
- batteries are to be inserted with the correct polarity;
- exhausted batteries are to be removed from the appliance and safely disposed of;
- if the appliance is to be stored unused for a long period, the batteries should be removed;
- the supply terminals are not to be short -circuited.

1.5 Scope of use of the product

Scope of application

The product is suitable for the following floors:

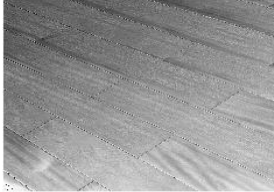

Wooden floor



Ceramic tile

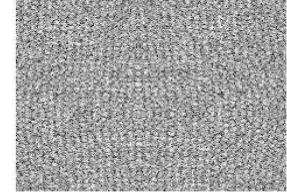

Short-staple carpet

1.6 Disclaimers

Under any of the following circumstances, the product will be excluded from the scope of free warranty, but paid repair can be provided:

- Damage due to the user's failure to operate the product in strict accordance with our user manual or due to improper storage;
- The machine or parts have exceeded the free warranty period;
- Damage due to disassembly by those other than the maintenance personnel of our company or authorized by our company;
- A valid purchase voucher number cannot be provided;
- The product model on the warranty card does not match that of the product to be repaired or is altered;
- Damage caused by irresistible factors such as natural disasters;
- Product failure or damage caused by unexpected factors or man-made causes (including operational errors, liquid ingress, improper plugging/unplugging, scratching, handling, bumping, input of inappropriate voltage, etc.)

Note: Our company provides a warranty for the product in accordance with the "National New Regulations on Warranty". For details, please check the warranty card provided with the product.

2. Product Composition

2.1 Host machine and accessories of the product



Host machine ×1



Charging dock ×1

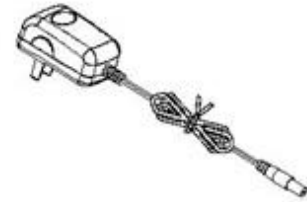

Power adapter
×1



Edgewise sweep ×4 (2 optional)

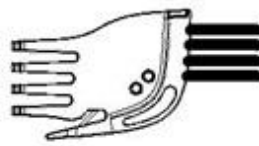

Cleaning brush ×1 (optional)

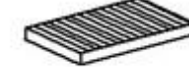

Filter combination ×1
(optional)



Instructions ×1

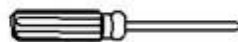

Screwdriver ×1
(optional)

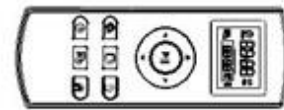

Remote controller ×1
(optional)
See the attached page of remote
control operation instructions
for real image

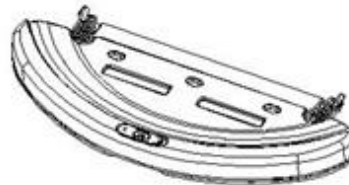

Water tank ×1 (optional)



Mop ×1 (optional)



Dry cell ×2 (optional)



Virtual magnetic stripe wall ×1
(optional)



Tip:

* A pair of side brushes, a filter combination and batteries have been installed in the host machine.

2.2 Names of parts

Front view of the machine

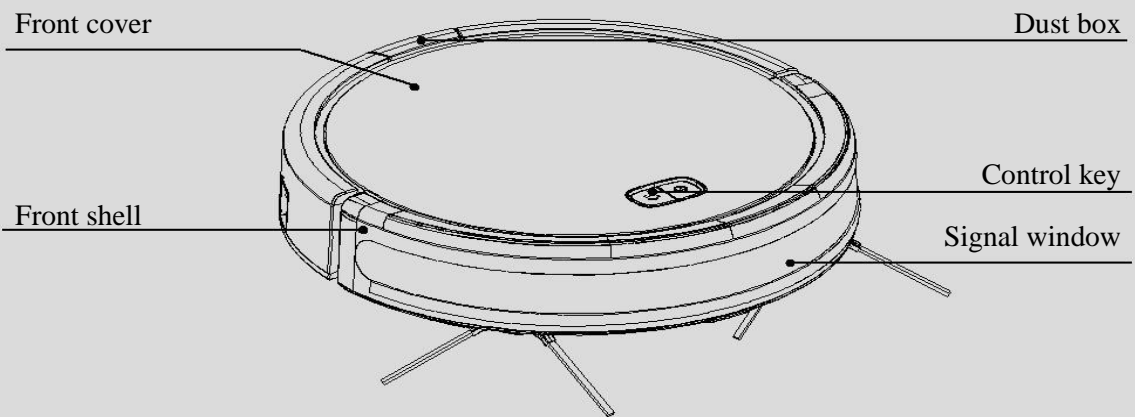

Bottom view of the machine

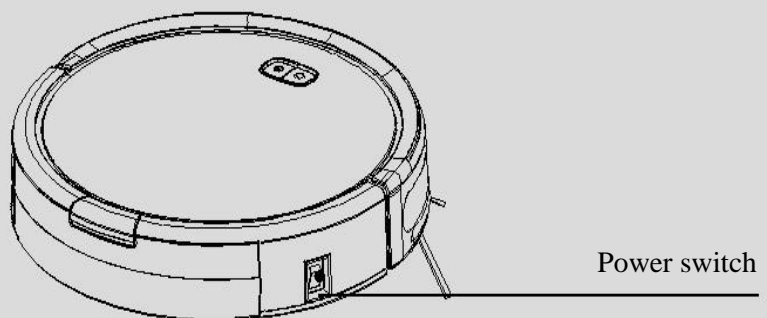
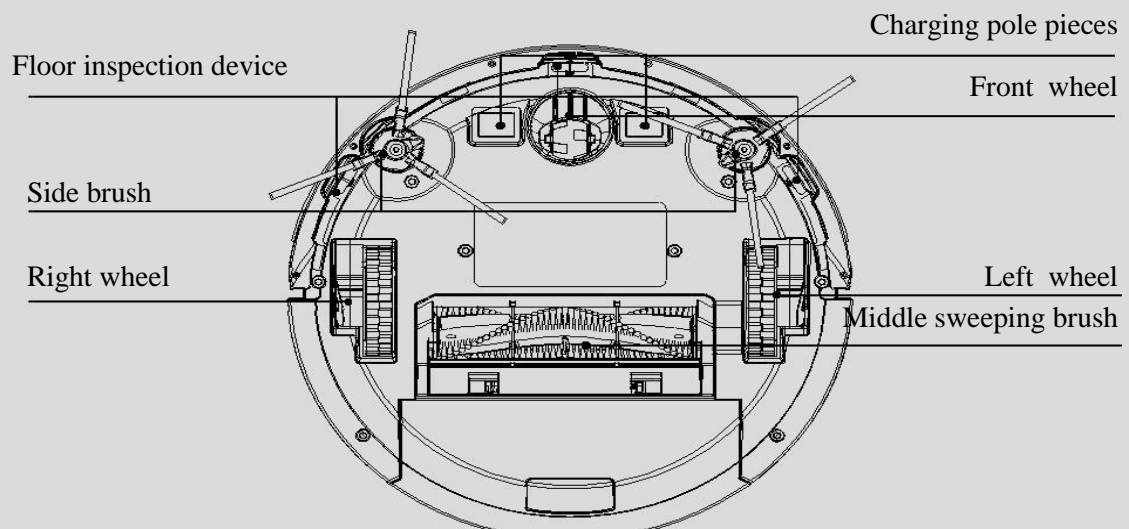

3. Product Installation

Charging dock installation

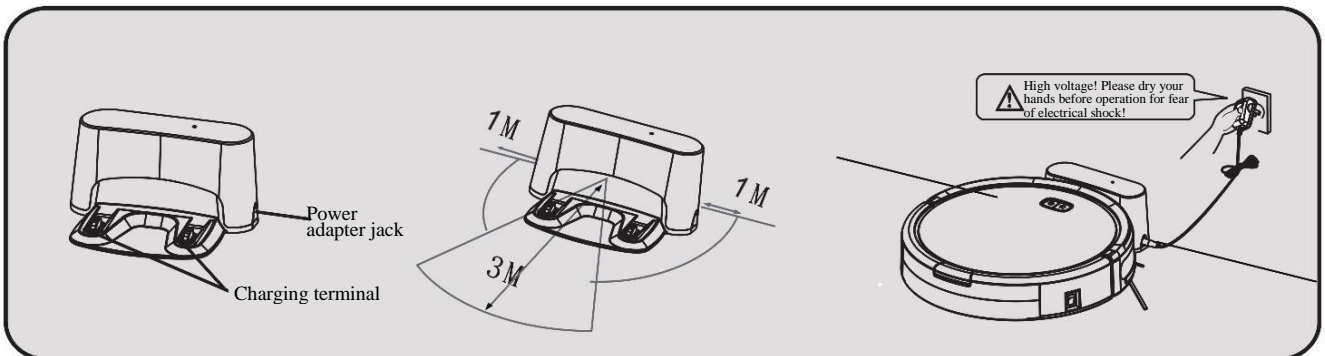

1. Place the charging dock on a flat surface that is perpendicular to the wall. There shall be no obstacles within 3 meters in front and 1 meter on the left and right. Press firmly on the charging dock to attach it to the floor more firmly. After plugging the adapter into the power supply, insert the DC plug into the DC port of the charging dock.
2. Connect the power adapter to the charging dock and power supply. Remember to put the adapter cable orderly, so that it will not be entangled during the operation of the vacuum cleaner.

Tip:

Try not to place the charging dock on the carpet. It is advisable to put the charging dock in a fixed position. Try not to move the charging dock in the working process of the machine, which will make it hard to find the charging dock.

3.2 Remote control installation

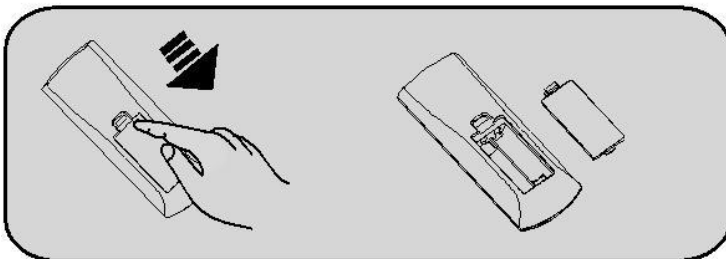

1. Open the battery cover.

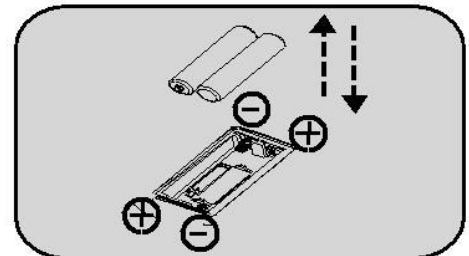

2. Put two AAA (No. 7) batteries into the battery compartment to match the positive and negative poles.

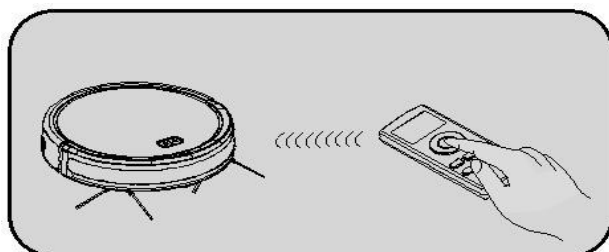



3. After installing the batteries, turn on the power switch of the vacuum cleaner. Check whether the remote control can control the vacuum cleaner. If there is no response, please refer to Page 10 to conduct remote control code pairing.

4. Product Use

4.1 Use of the host machine

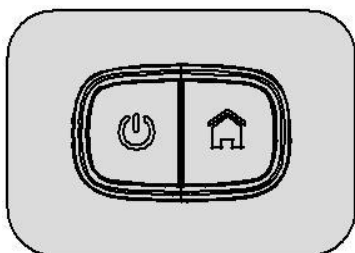
4.1.1 Diagrams of control keys



Control Keys	
	Power key
	Recharge key

4.1.2 Working mode:

4.1.2.1 Manual mode

Standby mode

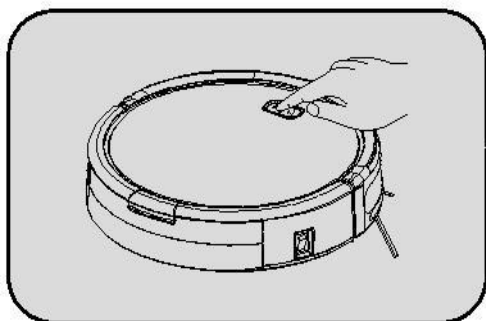

Automatic cleaning

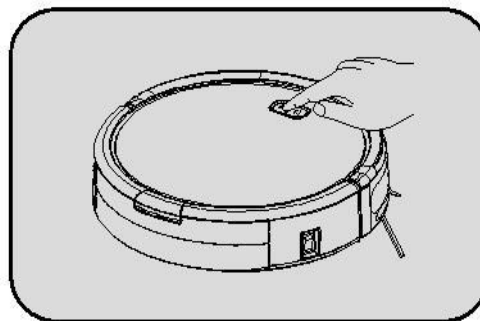

1. Make sure that the batteries of the vacuum cleaner are fully charged, and turn on the machine switch to enter the standby state.

2. When the vacuum cleaner is in the standby state, press the power key, and the vacuum cleaner will start to clean automatically.

Automatic recharge

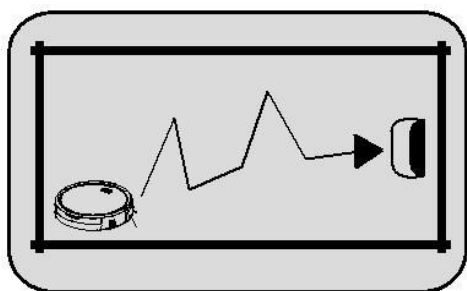











3. When the vacuum cleaner is in the standby state, press the recharge key, and the machine will start to operate, with the recharge key flashing blue, to enter the recharge mode.

Tips:

- * To ensure work efficiency during the operation of the machine, please do not control the machine randomly.
- * The machine may have a short pause during work, so please wait patiently. The number and time of pauses depend on the complexity of the home environment.

4.1.3 Operation guide for key indicating light

SN	State	Display	Operation
1	Off	Light off	<ol style="list-style-type: none"> 1. Have a long pressing of the  key for 3 seconds, and release it when a beep is heard. 2. Turn off the machine power switch.
2	On	Light on	<ol style="list-style-type: none"> 1. If the power switch is turned on, press the  key. 2. If the power switch is not turned on, turn on the power switch to start the machine.
3	Clean	 Blue light normally on	Press the  key on the front cover of the machine to start cleaning.
4	Search for recharge	 Blue light flashing	Press the  key on the front cover of the machine to start recharging.
5	Charging	 Blue breathing light	The machine is being charged on the charging dock.
6	Full charge	 Blue light normally on	The machine is fully charged.
7	Error report	  Two red lights flashing	Machine abnormality or fault
8	Sleep	Light off	It goes into the sleep mode after being in standby mode for five minutes.

4.2 Charging method

4.2.1 Manual charging:

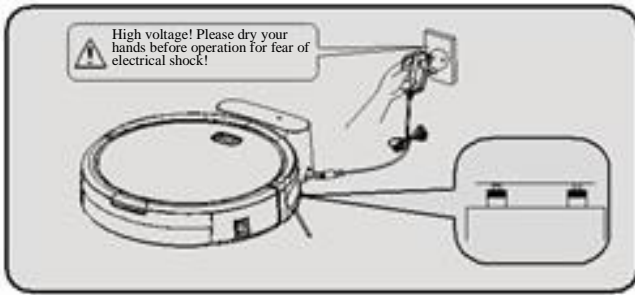

1. Use the charging dock for charging:

First connect the power adapter with the charging dock, then connect with the power supply; put the vacuum cleaner on the charging dock to charge (The blue light of the recharge key flashes during charging, and the blue light is normally on after the battery is fully charged).

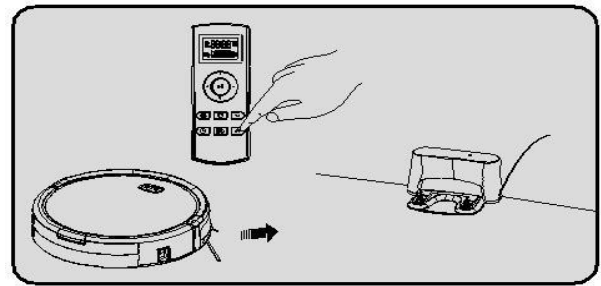

2. Use the remote control for charging:

Carry out code pairing between the vacuum cleaner and the remote control, and then press the "Recharge" key. The vacuum cleaner automatically searches for the charging dock for charging within the effective range.

4.2.2 Automatic charging:

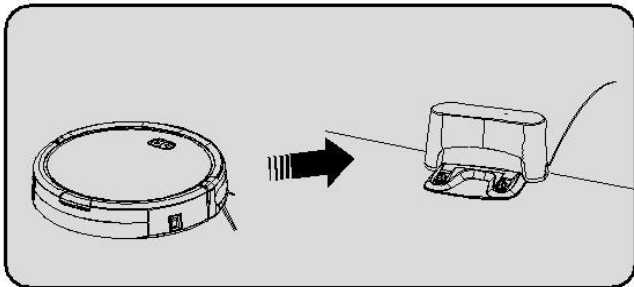

Automatic charging:

In case of low battery during the operation of the machine, the blue light of the recharge key will flash, and the machine will enter the recharge mode.

5. Product Maintenance

Tip:

Please clean and maintain the vacuum cleaner regularly according to the use conditions.

5.1 Clean the charging pole pieces

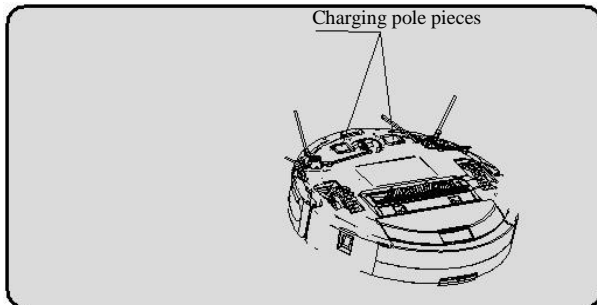

1. Please turn off the power switch or unplug the power cord first.
2. Please use a dry cloth to wipe them once a month.
3. Do not scrub with oil.

5.2 Clean the dust box

5.2.1 Install and remove the dust box

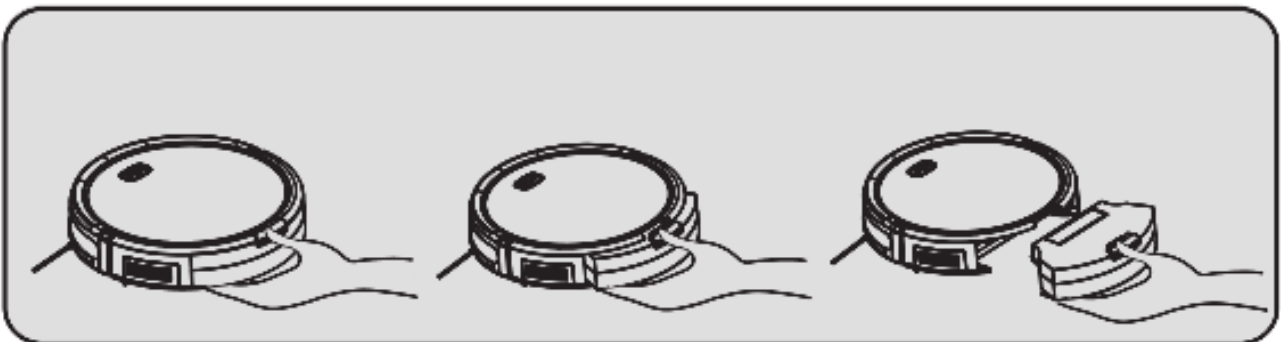

As shown in the figure above, press the “” key on the dust box to eject the dust box, and then remove the dust box.

5.2.2 Clean the dust box

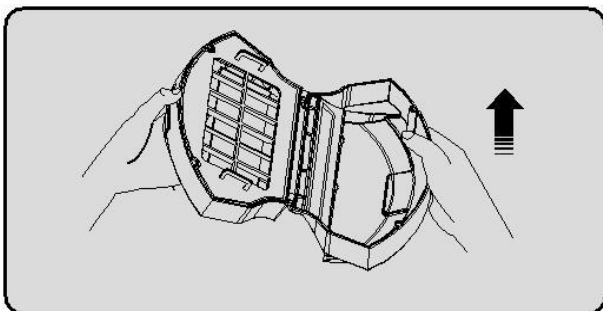

1. Open the dust box cover and pour out the dust.
Advice: Clean the dust box every three days at first for the new machine, and clean it once a week subsequently.

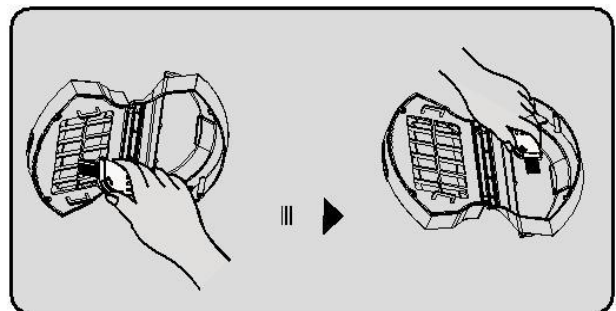

2. As shown above, use a cleaning brush to clean it.

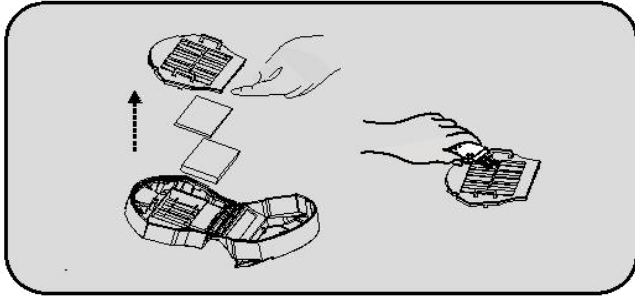

3. Remove the filter assembly and use a cleaning brush to clear away the dust on the filter screen.

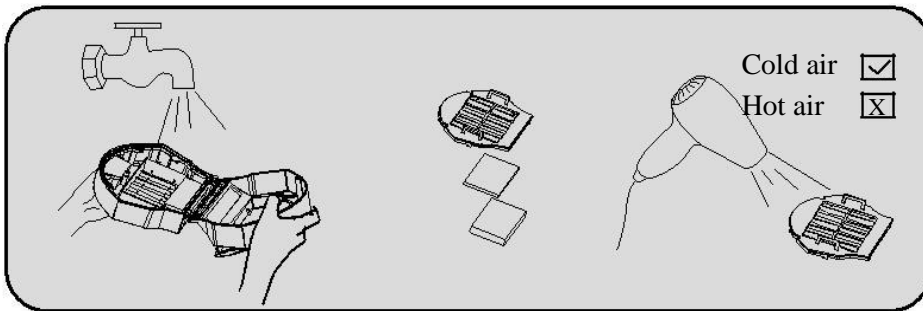

4. The inside of the dust box and the filter screen can be flushed under running water. (Note: You need to dry it thoroughly before you can put them back into the vacuum cleaner.)

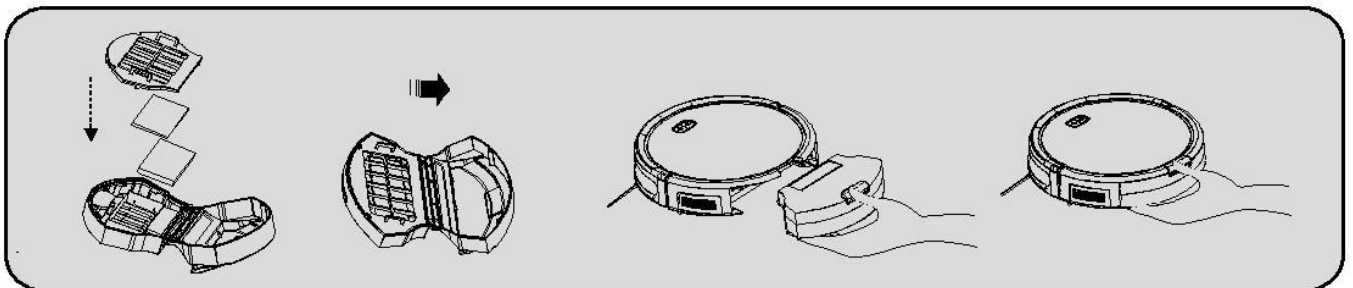

5. After cleaning, reinstall the filter screen, close the dust box cover, and finally put the dust box into the vacuum cleaner.

5.3 Clean the middle sweeper

5.3.1 Remove the middle sweeper

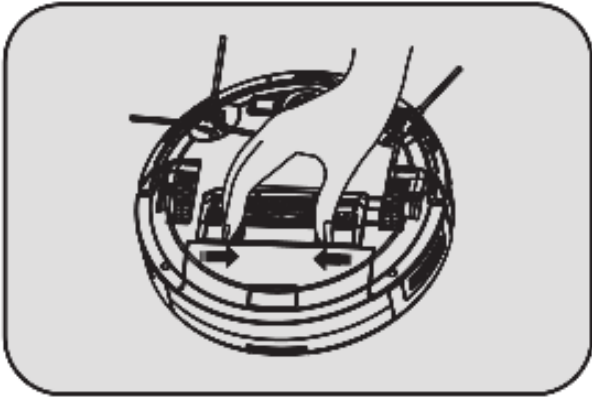

1. As shown in the figure, push the lock lever to the middle, and lift it up.

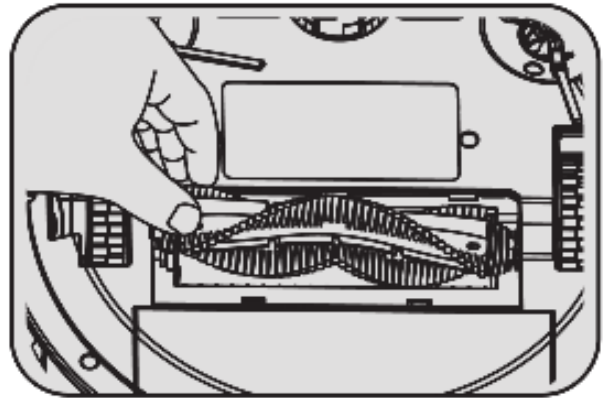

2. Grab the middle sweeping brush and lift it up.

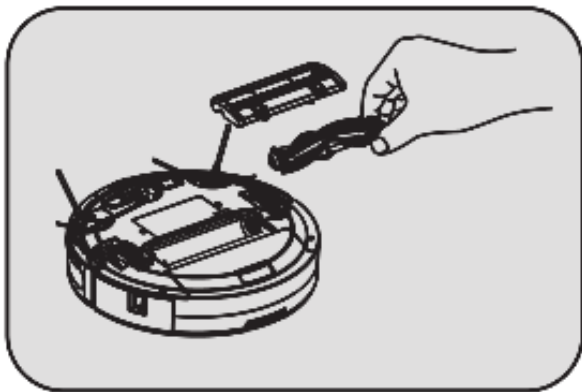

3. Remove the middle sweeping scraper assembly and the middle sweeping brush.

5.3.2 Clean the middle sweeping brush

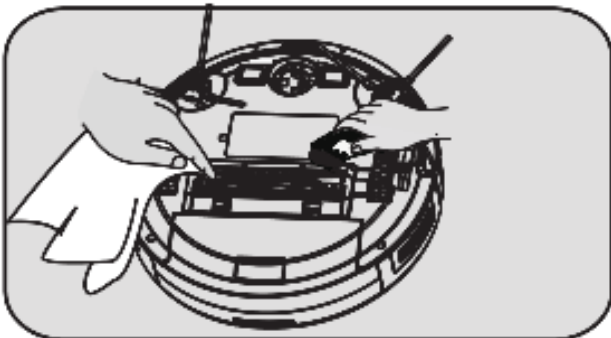

1. As shown in the figure, please use a cleaning brush to clean the middle sweeping soft brush and the middle sweeping rubber brush regularly.

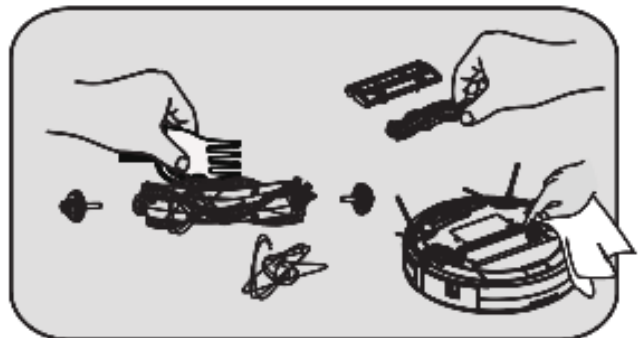

2. As shown in the figure above, regularly clean the hair and other entanglements on the sweeping brush.

5.4 Clean the side brush

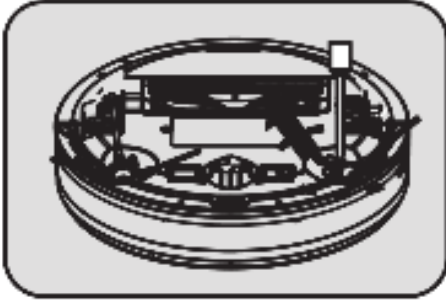

1. Use a screwdriver to remove the screws from the side brush.

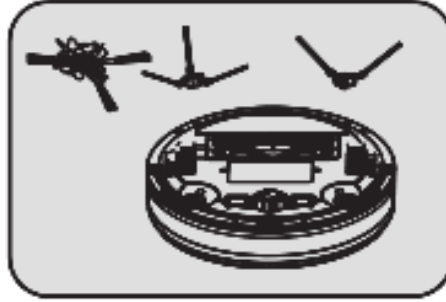

2. Remove the side brush and clear away the hair and other rubbish on the side brush. Then clear away the entanglements in the slot of the side brush.

5.5 Clean the wheels



Clean the front, left and right wheels regularly with a cleaning brush.

(Note: The wheel shaft may be entangled by hair, cloth strips, etc., so please clean it in time.)

5.6 Clean the sensor

It is recommended that every time after the cleaning work is completed, a dry cotton cloth should be used to carefully wipe the light-transmitting plate of the sensor to prevent dust accumulation on it, which will affect the performance of the product.

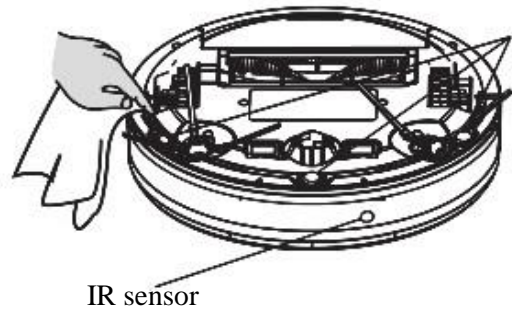





Bottom view of sensor

6. Troubleshooting

Fault indication by light flashing	Fault name	Fault description	Solution
The red light flashes twice, and 1 beep can be heard.	Left wheel fault	The left wheel does not rotate, as the left wheel is overloaded.	Please check whether the left wheel of the machine gets entangled.
The red light flashes 3 times, and 1 beep can be heard.	Right wheel fault	The right wheel does not rotate, as the right wheel is overloaded.	Please check whether the right wheel of the machine gets entangled.
The red light flashes 5 times, and 1 beep can be heard.	Front wheel fault	The front wheel is stuck and does not rotate.	Please check whether the front wheel gets entangled.
The red light flashes 6 times, and 1 beep can be heard.	Floor inspection fault or suspension fault	Cliff or the sensor is dirty or the machine is off the floor.	Please check whether the sensor at the bottom of the machine is blocked abnormally or do not leave the machine in a suspended state.
The red light flashes 7 times, and 1 beep can be heard.	The battery charge level is low	The battery charge level has reached its lower limit (other than recharge voltage threshold).	Please allow the machine to return to the charging post for recharge.
The red light flashes 8 times, and 1 beep can be heard.	Front collision fault	The front shell collision switch does not reset.	Please check whether the machine collision buffer is normal or loose.
The red light flashes 9 times, and 1 beep can be heard.	Middle sweeper fault	The rolling brush is stuck.	Please check whether the middle sweeping brush of the machine is entangled by any foreign object.
The red light flashes 10 times, and 1 beep can be heard.	Side sweeping fault	The side brush is stuck.	Please check whether the side sweeping brush of the machine is entangled by any foreign object.
The red light flashes 11 times, and 1 beep can be heard.	Wall inspection fault	There is a problem with the wall inspection.	Please check whether the wall inspection transparent window is blocked or interfered by any foreign object.
The red light flashes 12 times, and 1 beep can be heard.	Fan fault	The fan does not rotate, and the current is large.	Please check whether the fan blades are loose or are entangled by any foreign object.
The red light flashes 14 times, and 1 beep can be heard.	Charging fault	The battery is damaged or the battery cable is not in contact.	Please check whether the charging dock power supply is normal or replace the battery.

 Tip: If you can't eliminate the corresponding faults with the above methods, please contact our customer service staff in time.

7. Technical Parameters

Functional parameters of the host machine		Functional parameters of accessories	
Operating voltage	14.4 V 	Power adapter	
Rated power	24 W	Output voltage	19V 
Battery	Lithium battery	Output current	600mA 
Battery capacity	2500mAh	Charging dock	
Charging time	4-5 hours	Input voltage	19V 
Operating hours	Approx. 100 minutes	Remote controller	
Working temperature range	0 °C~60 °C	Remote control distance	20m
Operating humidity range	≤ 80%RH	Batteries	AAA (No. 7) dry battery*2
Noise	≤ 65dB		
Weight	3.5kg		
Dimensions	Ø325*85mm		

Tip:

Our company reserves the right to make any technical or design changes to the product due to continuous product improvement needs.

The right of interpretation belongs to our company.

■ Names and contents of harmful substances in the product

Component Name	Harmful Substances					
	Lead (Pb)	Mercury (Hg)	Cadmium (Cd)	Hexavalent chromium (Cr (VI))	Polybrominated biphenyl (PBB)	Polybrominated diphenyl ethers (PBDE)
Shell component	○	○	○	○	○	○
Internal plastic parts	○	○	○	○	○	○
Metal parts	X	○	○	○	○	○
Electrical components and control components	X	○	X	○	○	○
Dry batteries	X	○	○	○	○	○
Rechargeable batteries	X	○	○	○	○	○

This form is prepared in accordance with the provisions of SJ/T 11364.

○: It indicates that the contents of the hazardous substance in all homogeneous materials of this part are below the required limit specified in GB/T 26572.

X: It indicates that the content of the hazardous substance in at least one of the homogeneous materials of this part exceeds the required limit specified in GB/T 26572.

(All parts marked with "X" in the form are in conformity to the EU RoHS Directive, or cannot be replaced by hazardous substances due to global technological development limits.)

(This form indicates that these hazardous substances exist in our company's products, but not all of the products included in the package contain all of the above parts.)

 The service life of the dry batteries used with the product is 3 years.

 The service life of the rechargeable battery used with the product is 5 years.

Warranty Card II

User name		(II) Settlement form of the warranty provider
Address		
Tel.		
Postal code		
Product model		
Purchase date		
Invoice number		
Warranty period		
<p>Product warranty description:</p> <ol style="list-style-type: none"> 1. From the date of the user's purchase of this product, the warranty period is one year for the host machine, and six months for the adapter, rechargeable batteries and other accessories. 2. After receiving the product repair request, the after-sales service staff will solve the problem within 15 working days. 3. The user can learn about relevant technical problems through the user manual of the product or the after-sales service hotline, and get a clear solution. Hotline: 400-0368-163 4. When a performance failure occurs during the user's normal use, our company promises to provide the above warranty services unless otherwise stipulated by the applicable laws, rules and regulations of the state. 5. During the warranty period, paid maintenance services will be provided under any of the following circumstances: <ol style="list-style-type: none"> (1) Damage caused by man-made factors or irresistible natural phenomena; (2) Failure or damage caused by improper operation of the user; (3) Damage due to the user's disassembly or alteration without authorization. 		



Warranty Card I

User name		(I) To be kept by the user as warranty certificate, which will not be reissued if lost
Address		
Tel.		
Postal code		
Product model		
Purchase date		
Invoice number		
Warranty period		
Date	Repairman	Maintenance record

FCC Warning

This device complies with part 15 of the FCC rules. Operation is subject to the following two conditions: (1) this device may not cause harmful interference, and (2) this device must accept any interference received, including interference that may cause undesired operation.

Changes or modifications not expressly approved by the party responsible for compliance could void the user's authority to operate the equipment.

NOTE: This equipment has been tested and found to comply with the limits for a Class B digital device, pursuant to part 15 of the FCC Rules. These limits are designed to provide reasonable protection against harmful interference in a residential installation. This equipment generates uses and can radiate radio frequency energy and, if not installed and used in accordance with the instructions, may cause harmful interference to radio communications. However, there is no guarantee that interference will not occur in a particular installation. If this equipment does cause harmful interference to radio or television reception, which can be determined by turning the equipment off and on, the user is encouraged to try to correct the interference by one or more of the following measures:

-Reorient or relocate the receiving antenna.

- Increase the separation between the equipment and receiver.
- Connect the equipment into an outlet on a circuit different from that to which the receiver is connected.
- Consult the dealer or an experienced radio/TV technician for help.

Radiation Exposure Statement

To comply with FCC RF exposure compliance requirements, this grant is applicable to only mobile configurations. The antennas used for this transmitter must be installed to provide a separation distance of at least 20cm from all persons and must not be co-located or operating in conjunction with any other antenna or transmitter.