

FCC SAR Measurement and Test Report

For

Shenzhen Inrico Electronics Co.,LTD

3/F, Building NO.118, High Tech Industrial Park,72 Guowei Road, Luohu

District, Shenzhen, China

FCC ID: 2AIV6-T522

Test Standards:	FCC Part 2.1093 ANSI / IEEE C95.1 ::2005+A1:2010 ANSI / IEEE C95.3 : 2002(R2008) <u>IEEE 1528 :2013</u>
Product Description:	<u>Network Two Way Radio</u>
Tested Model:	<u>T522</u>
Report No.:	<u>WTX19X07046957W-3</u>
Sample Received Date:	<u>2019-07-11</u>
Tested Date:	<u>2019-07-11 to 2019-08-16</u>
Issued Date:	<u>2019-08-19</u>
Tested By:	<u>Ruler Liu / Engineer</u> <i>Ruler Liu</i>
Reviewed By:	<u>Silin Chen / EMC Manager</u> <i>Silin Chen</i>
Approved & Authorized By:	<u>Jandy So / PSQ Manager</u> <i>Jandy So</i>
Prepared By:	

Shenzhen SEM Test Technology Co. Ltd.
1/F, Building A, Hongwei Industrial Park, Liuxian 2nd Road,
Bao'an District, Shenzhen, P.R.C. (518101)
Tel.: +86-755-33663308 Fax.: +86-755-33663309 Website: www.semtest.com.cn

Note: This test report is limited to the above client company and the product model only. It may not be duplicated without prior permitted by Shenzhen SEM Test Technology Co., Ltd.

TABLE OF CONTENTS

1. General Information3

 1.1 Product Description for Equipment Under Test (EUT)3

 1.2 Test Standards5

 1.3 Test Methodology5

 1.4 Test Facility5

2. Summary of Test Results6

3. Specific Absorption Rate (SAR).....7

 3.1 Introduction.....7

 3.2 SAR Definition7

4. SAR Measurement System8

 4.1 The Measurement System8

 4.2 Probe8

 4.3 Probe Calibration Process10

 4.4 Phantom11

 4.5 Device Holder11

 4.6 Test Equipment List12

5. Tissue Simulating Liquids13

 5.1 Composition of Tissue Simulating Liquid13

 5.2 Tissue Dielectric Parameters for Head and Body Phantoms14

 5.3 Tissue Calibration Result15

6. SAR Measurement Evaluation16

 6.1 Purpose of System Performance Check16

 6.2 System Setup16

 6.3 Validation Results17

7. EUT Testing Position18

 7.1 EUT Antenna Position18

 7.2 EUT Testing Position19

8. SAR Measurement Procedures20

 8.1 Measurement Procedures20

 8.2 Spatial Peak SAR Evaluation20

 8.3 Area & Zoom Scan Procedures21

 8.4 Volume Scan Procedures21

 8.5 SAR Averaged Methods21

 8.6 Power Drift Monitoring21

9. SAR Test Result22

 9.1 Conducted RF Output Power22

 9.2 Test Results for Standalone SAR Test49

10. Measurement Uncertainty54

 10.1 Uncertainty for EUT SAR Test54

 10.2 Uncertainty for System Performance Check55

Annex A. Plots of System Performance Check57

Annex B. Plots of SAR Measurement73

Annex C. EUT Photos102

Annex D. Test Setup Photos104

Annex E. Calibration Certificate105

1. General Information

1.1 Product Description for Equipment Under Test (EUT)

Client Information

Applicant: Shenzhen Inrico Electronics Co.,LTD
Address of applicant: 3/F, Building NO.118, High Tech Industrial Park,72 Guowei Road, Luohu District, Shenzhen, China

Manufacturer: Shenzhen Inrico Electronics Co.,LTD
Address of manufacturer: 3/F, Building NO.118, High Tech Industrial Park,72 Guowei Road, Luohu District, Shenzhen, China

General Description of EUT:	
Product Name:	Network Two Way Radio
Brand Name:	/
Model No.:	T522
Adding Model(s):	/
Rated Voltage:	DC3.7V
Battery:	4000mAh
<i>Note: The test data is gathered from a production sample provided by the manufacturer.</i>	

Technical Characteristics of EUT:	
3G	
Support Networks:	WCDMA, HSDPA, HSUPA
Support Band:	WCDMA Band 2, WCDMA Band 5
Uplink Frequency:	WCDMA Band 2: 1850~1910MHz WCDMA Band 5: 824~849MHz
Downlink Frequency:	WCDMA Band 2: 1930~1990MHz WCDMA Band 5: 869~894MHz
RF Output Power:	WCDMA Band 2: 22.10dBm, WCDMA Band 5: 22.86dBm
Type of Modulation:	BPSK, QPSK
Antenna Type:	Integral Antenna
Antenna Gain:	WCDMA Band 2: 0.8dBi, WCDMA Band 5: -1.2dBi
4G	
Support Networks:	FDD-LTE
Support Band:	FDD-LTE Band 2, 4, 5, 12,17
Uplink Frequency:	FDD-LTE Band 2: Tx: 1850-1910MHz, FDD-LTE Band 4: Tx: 1710-1755MHz, FDD-LTE Band 5: Tx: 824-849MHz, FDD-LTE Band 12: Tx: 699-716MHz, FDD-LTE Band 17: Tx: 704-716MHz
Downlink Frequency:	FDD-LTE Band 2: Rx: 1930-1990MHz, FDD-LTE Band 4: Rx: 2110-2155MHz, FDD-LTE Band 5: Rx: 869-894MHz, FDD-LTE Band 12: Rx: 729-746MHz, FDD-LTE Band 17: Rx: 734-746MHz
RF Output Power:	FDD-LTE Band 2: 24.38dBm, FDD-LTE Band 4: 24.67dBm, FDD-LTE Band 5: 23.38dBm, FDD-LTE Band 12: 23.27dBm, FDD-LTE Band 17: 23.15dBm
Type of Modulation:	QPSK, 16QAM
Antenna Type:	Integral Antenna
Antenna Gain:	FDD-LTE Band 2: 0.8dBi, FDD-LTE Band 4: 0.6dBi, FDD-LTE Band 5: -1.2dBi, FDD-LTE Band 12: -2.1dBi, FDD-LTE Band 17: -2.1dBi,

1.2 Test Standards

The following report is prepared on behalf of the Shenzhen Inrico Electronics Co.,LTD in accordance with FCC 47 CFR Part 2.1093, ANSI/IEEE C95.1-2005, ANSI / IEEE C95.3 :2002, IEEE 1528-2013, KDB 447498 D01 v06, KDB 648474 D04 v01r03, KDB 941225 D01 v03r01, KDB 941225 D05 v02r05 and KDB 865664 D01 v01r04 and KDB 865664 D02 v01r02 and KDB 248227 D01 v02r02.

The objective is to determine compliance with FCC Part 2.1093 of the Federal Communication Commissions rules.

Maintenance of compliance is the responsibility of the manufacturer. Any modification of the product, which result in lowering the emission, should be checked to ensure compliance has been maintained.

1.3 Test Methodology

All measurements contained in this report were conducted with KDB 865664 D01 v01r04 and KDB 865664 D02 v01r02. The public notice KDB 447498 D01 v06 for Mobile and Portable Devices RF Exposure Procedure also.

1.4 Test Facility

FCC – Registration No.: 125990

Shenzhen SEM Test Technology Co., Ltd. Laboratory has been recognized to perform compliance testing on equipment subject to the Commissions Declaration Of Conformity (DOC). The Designation Number is CN5010, and Test Firm Registration Number is 125990.

Industry Canada (IC) Registration No.: 11464A

The 3m Semi-anechoic chamber of Shenzhen SEM.Test Technology Co., Ltd. has been registered by Certification and Engineering Bureau of Industry Canada for radio equipment testing with Registration No.: 11464A.

2. Summary of Test Results

The maximum results of Specific Absorption Rate (SAR) have found during testing are as follows:

Front-of-face(25mm Gap)

Frequency Band	Front-of-face (25mm Gap)	SAR _{1g} Limit (W/kg)
	Maximum SAR _{1g} (W/kg)	
WCDMA	0.405	1.6
LTE	0.679	1.6

Body(0mm Gap)

Frequency Band	Body (0mm Gap)	SAR _{1g} Limit (W/kg)
	Maximum SAR _{1g} (W/kg)	
WCDMA	1.011	1.6
LTE	1.142	1.6

Remark:

The highest reported SAR values for Front-of-face and body us transmission conditions are 1.011W/kg, and 1.142W/kg respectively.

The device is in compliance with Specific Absorption Rate (SAR) for general population/uncontrolled exposure limits (1.6 W/kg) specified in FCC 47 CFR Part 2.1093 and ANSI/IEEE C95.1-2005, and had been tested in accordance with the measurement methods and procedure specified in IEEE 1528-2013 and KDB 865664 D01 v01r04 and KDB 865664 D02 v01r02

3. Specific Absorption Rate (SAR)

3.1 Introduction

SAR is related to the rate at which energy is absorbed per unit mass in an object exposed to a radio field. The SAR distribution in a biological body is complicated and is usually carried out by experimental techniques or numerical modeling. The standard recommends limits for two tiers of groups, occupational/controlled and general population/uncontrolled, based on a person's awareness and ability to exercise control over his or her exposure. In general, occupational/controlled exposure limits are higher than the limits for general population/uncontrolled.

3.2 SAR Definition

The SAR definition is the time derivative (rate) of the incremental energy (dW) absorbed by (dissipated in) an incremental mass (dm) contained in a volume element (dv) of a given density (ρ). The equation description is as below:

$$\text{SAR} = \frac{d}{dt} \left(\frac{dW}{dm} \right) = \frac{d}{dt} \left(\frac{dW}{\rho dv} \right)$$

SAR is expressed in units of Watts per kilogram (W/kg)

SAR measurement can be either related to the temperature elevation in tissue by

$$\text{SAR} = C \left(\frac{\delta T}{\delta t} \right)$$

Where: C is the specific heat capacity, δT is the temperature rise and δt is the exposure duration, or related to the electrical field in the tissue by

$$\text{SAR} = \frac{\sigma |E|^2}{\rho}$$

Where: σ is the conductivity of the tissue, ρ is the mass density of the tissue and E is the RMS electrical field strength.

However for evaluating SAR of low power transmitter, electrical field measurement is typically applied.

4. SAR Measurement System

4.1 The Measurement System

Comosar is a system that is able to determine the SAR distribution inside a phantom of human being according to different standards. The Comosar system consists of the following items:

- Main computer to control all the system
- 6 axis robot
- Data acquisition system
- Miniature E-field probe
- Phone holder
- Head simulating tissue

The following figure shows the system.



The EUT under test operating at the maximum power level is placed in the phone holder, under the phantom, which is filled with head simulating liquid. The E-Field probe measures the electric field inside the phantom. The OpenSAR software computes the results to give a SAR value in a 1g or 10g mass.

4.2 Probe

For the measurements the Specific Dosimetric E-Field Probe SSE5 SN 09/13 EP168 with following specifications is used

- Dynamic range: 0.01-100 W/kg
- Probe Length: 330 mm
- Length of Individual Dipoles: 4.5 mm
- Maximum external diameter: 8 mm
- Probe Tip External Diameter : 5 mm
- Distance between dipoles / probe extremity: 2.7mm

- Probe linearity: <0.25 dB
 - Axial Isotropy: <0.25 dB
 - Spherical Isotropy: <0.50 dB
 - Calibration range: 700 to 3000MHz for head & body simulating liquid.
- Angle between probe axis (evaluation axis) and surface normal line: less than 30°

Probe calibration is realized, in compliance with EN 62209-1 and IEEE 1528 STD, with CALISAR, Antenna proprietary calibration system. The calibration is performed with the EN 62209-1 annexe technique using reference guide at the five frequencies.

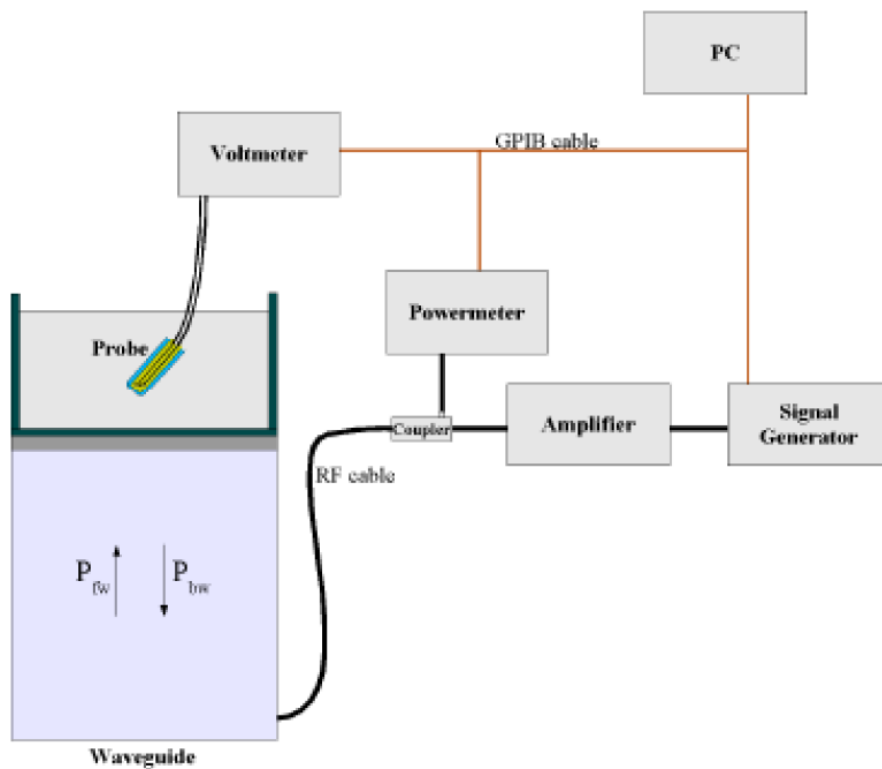

$$SAR = \frac{4(P_{fw} - P_{bw})}{ab\delta} \cos^2\left(\pi \frac{y}{a}\right) e^{-2z/\delta}$$

Where :

P_{fw} = Forward Power

P_{bw} = Backward Power

a and b = Waveguide dimensions

δ = Skin depth

Keithley configuration:

Rate = Medium; Filter = ON; RDGS = 10; Filter type = Moving Average; Range auto after each calibration, a SAR measurement is performed on a validation dipole and compared with a NPL calibrated probe, to verify it.

The calibration factors, CF(N), for the 3 sensors corresponding to dipole 1, dipole 2 and dipole 3 are:

$$CF(N)=SAR(N)/V_{lin}(N) \quad (N=1,2,3)$$

The linearised output voltage $V_{lin}(N)$ is obtained from the displayed output voltage $V(N)$ using

$$V_{lin}(N)=V(N)*(1+V(N)/DCP(N)) \quad (N=1,2,3)$$

where DCP is the diode compression point in mV.

4.3 Probe Calibration Process

Dosimetric Assessment Procedure

Each E-Probe/Probe Amplifier combination has unique calibration parameters. SATIMO Probe calibration procedure is conducted to determine the proper amplifier settings to enter in the probe parameters. The amplifier settings are determined for a given frequency by subjecting the probe to a known E-field density (1 mW/cm²) using an with CALISAR, Antenna proprietary calibration system.

Free Space Assessment Procedure

The free space E-field from amplified probe outputs is determined in a test chamber. This calibration can be performed in a TEM cell if the frequency is below 1 GHz and in a waveguide or other methodologies above 1 GHz for free space. For the free space calibration, the probe is placed in the volumetric center of the cavity and at the proper orientation with the field. The probe is rotated 360 degrees until the three channels show the maximum reading. The power density readings equates to 1mW/cm².

Temperature Assessment Procedure

E-field temperature correlation calibration is performed in a flat phantom filled with the appropriate simulated head tissue. The E-field in the medium correlates with the temperature rise in the dielectric medium. For temperature correlation calibration a RF transparent thermistor-based temperature probe is used in conjunction with the E-field probe.

Where:

$$SAR = C \frac{\Delta T}{\Delta t}$$

Δt = exposure time (30 seconds),

C = heat capacity of tissue (brain or muscle),

ΔT = temperature increase due to RF exposure.

SAR is proportional to $\Delta T/\Delta t$, the initial rate of tissue heating, before thermal diffusion takes place. The electric field in the simulated tissue can be used to estimate SAR by equating the thermally derived SAR to that with the E- field component.

$$\text{SAR} = \frac{|E|^2 \cdot \sigma}{\rho}$$

Where:

σ = simulated tissue conductivity,

ρ = Tissue density (1.25 g/cm³ for brain tissue)

4.4 Phantom

For the measurements the Specific Anthropomorphic Mannequin (SAM) defined by the IEEE SCC-34/SC2 group is used. The phantom is a polyurethane shell integrated in a wooden table. The thickness of the phantom amounts to 2mm +/- 0.2mm. It enables the dosimetric evaluation of left and right phone usage and includes an additional flat phantom part for the simplified performance check. The phantom set-up includes a cover, which prevents the evaporation of the liquid.

4.5 Device Holder

The positioning system allows obtaining cheek and tilting position with a very good accuracy. In compliance with CENELEC, the tilt angle uncertainty is lower than 1°.

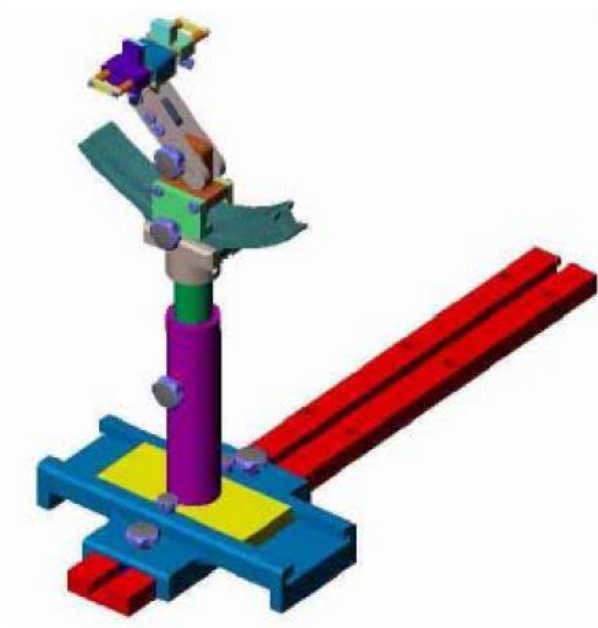

System Material	Permittivity	Loss Tangent
Delrin	3.7	0.005

4.6 Test Equipment List

Description	Manufacturer	Model	Serial Number	Cal. Date	Due. Date
E-Field Probe	MVG	SSE5	SN 09/13 EP168	2019-05-22	2020-05-21
750MHz Dipole	MVG	SID750	SN 47/12 DIP 0G750-203	2019-03-16	2020-03-15
835MHz Dipole	MVG	SID835	SN 47/12 DIP 0G835-204	2019-03-16	2020-03-15
1800MHz Dipole	MVG	SID1800	SN 47/12 DIP 1G800-206	2019-03-16	2020-03-15
1900MHz Dipole	MVG	SID1900	SN 47/12 DIP 1G900-207	2019-03-16	2020-03-15
Dielectric Probe Kit	SATIMO	SCLMP	SN 47/12 OCPG49	2019-03-16	2020-03-15
SAM Phantom	SATIMO	SAM	SN/ 47/12 SAM95	N/A	N/A
MULTIMETER	KEITHLEY	Keithley 2000	4006367	2019-04-30	2020-04-29
Signal Generator	Rohde & Schwarz	SMR20	100047	2019-04-30	2020-04-29
Universal Tester	Rohde & Schwarz	CMU200	112315	2019-04-30	2020-04-29
Communications Tester	Rohde & Schwarz	CMW500	148650	2019-04-30	2020-04-29
Network Analyzer	HP	8753C	SEMT-1064	2019-04-30	2020-04-29
Directional Couplers	Agilent	778D	20160	2019-04-30	2020-04-29

5. Tissue Simulating Liquids

5.1 Composition of Tissue Simulating Liquid

For the measurement of the field distribution inside the SAM phantom with SMTIMO, the phantom must be filled with around 25 liters of homogeneous body tissue simulating liquid. For head SAR testing, the liquid height from the ear reference point (ERP) of the phantom to the liquid top surface is larger than 15 cm. For body SAR testing, the liquid height from the center of the flat phantom to the liquid top surface is larger than 15 cm. The depth of tissue-equivalent liquid in a phantom must be ≥ 15.0 cm with $\leq \pm 0.5$ cm variation for SAR measurements ≤ 3 GHz. Please see the following photos for the liquid height.

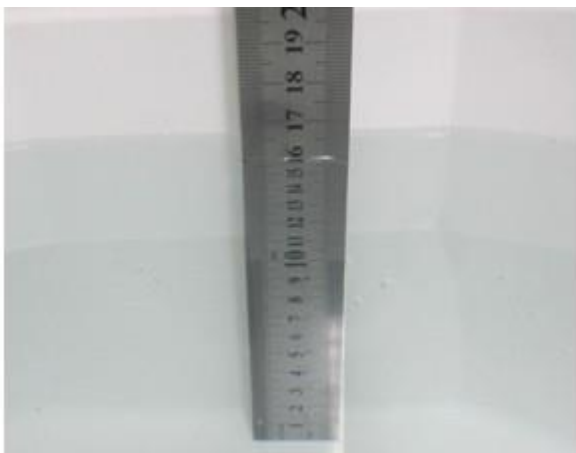

Liquid Height for Head SAR

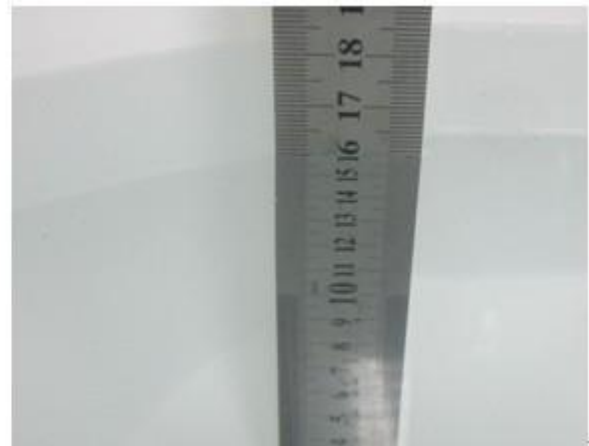

Liquid Height for Body SAR

The Composition of Tissue Simulating Liquid

Frequency (MHz)	Water (%)	Salt (%)	Sugar (%)	HEC (%)	Preventol (%)	DGBE (%)
Head						
750	41.1	1.4	57.0	0.2	0.3	0
835	40.3	1.4	57.9	0.2	0.2	0
1800-1900	55.2	0.3	0	0	0	44.5
Body						
750	50.0	0.8	48.8	0.2	0.2	0
835	50.8	0.9	48.1	0.1	0.1	0
1800-1900	70.2	0.4	0	0	0	29.4

5.2 Tissue Dielectric Parameters for Head and Body Phantoms

The head tissue dielectric parameters recommended by the IEEE SCC-34/SC-2 in P1528 have been incorporated in the following table. These head parameters are derived from planar layer models simulating the highest expected SAR for the dielectric properties and tissue thickness variations in a human head. Other head and body tissue parameters that have not been specified in P1528 are derived from the tissue dielectric parameters computed from the 4-Cole-Cole equations described in Reference [12] and extrapolated according to the head parameters specified in P1528.

Target Frequency (MHz)	Head		Body	
	Conductivity (σ)	Permittivity (ϵ_r)	Conductivity (σ)	Permittivity (ϵ_r)
150	0.76	52.3	0.80	61.9
300	0.87	45.3	0.92	58.2
450	0.87	43.5	0.94	56.7
750	0.89	41.9	0.96	55.5
835	0.90	41.5	0.97	55.2
900	0.97	41.5	1.05	55.0
915	0.98	41.5	1.06	55.0
1450	1.20	40.5	1.30	54.0
1610	1.29	40.3	1.40	53.8
1750	1.37	40.1	1.49	53.4
1800-2000	1.40	40.0	1.52	53.3
2450	1.80	39.2	1.95	52.7
3000	2.40	38.5	2.73	52.0
5800	5.27	35.3	6.00	48.2

5.3 Tissue Calibration Result

The dielectric parameters of the liquids were verified prior to the SAR evaluation using COMOSAR Dielectric Probe Kit and an Agilent Network Analyzer.

Calibration Result for Dielectric Parameters of Tissue Simulating Liquid

Head Tissue Simulating Liquid									
Freq. MHz.	Temp. (°C)	Conductivity			Permittivity			Limit (%)	Date
		Reading (σ)	Target (σ)	Delta (%)	Reading (ϵ_r)	Target (ϵ_r)	Delta (%)		
750	21.2	0.86	0.89	-3.37	41.32	41.90	-1.38	±5	2019-08-12
835	21.2	0.87	0.90	-3.33	41.11	41.50	-0.94	±5	2019-08-12
1750	21.3	1.37	1.37	0.00	39.02	40.1	-2.69	±5	2019-08-13
1800	21.3	1.37	1.40	-2.14	39.02	40.0	-2.45	±5	2019-08-13
1900	21.3	1.38	1.40	-1.43	38.56	40.00	-3.60	±5	2019-08-13

Body Tissue Simulating Liquid									
Freq. MHz.	Temp. (°C)	Conductivity			Permittivity			Limit (%)	Date
		Reading (σ)	Target (σ)	Delta (%)	Reading (ϵ_r)	Target (ϵ_r)	Delta (%)		
750	21.2	0.93	0.96	-3.12	54.96	55.50	-0.97	±5	2019-08-12
835	21.2	0.95	0.97	-2.06	54.85	55.20	-0.63	±5	2019-08-12
1750	21.3	1.46	1.49	-2.01	51.22	53.40	-4.08	±5	2019-08-13
1800	21.3	1.46	1.52	-3.95	51.22	53.30	-3.90	±5	2019-08-13
1900	21.3	1.50	1.52	-1.32	52.42	53.30	-1.65	±5	2019-08-13

6. SAR Measurement Evaluation

6.1 Purpose of System Performance Check

The system performance check verifies that the system operates within its specifications. System and operator errors can be detected and corrected. It is recommended that the system performance check be performed prior to any usage of the system in order to guarantee reproducible results. The system performance check uses normal SAR measurements in a simplified setup with a well characterized source. This setup was selected to give a high sensitivity to all parameters that might fail or vary over time. The system check does not intend to replace the calibration of the components, but indicates situations where the system uncertainty is exceeded due to drift or failure.

6.2 System Setup

In the simplified setup for system evaluation, the EUT is replaced by a calibrated dipole and the power source is replaced by a continuous wave which comes from a signal generator at frequency 835 MHz and 1900MHz. The calibrated dipole must be placed beneath the flat phantom section of the SAM twin phantom with the correct distance holder. The distance holder should touch the phantom surface with a light pressure at the reference marking and be oriented parallel to the long side of the phantom.

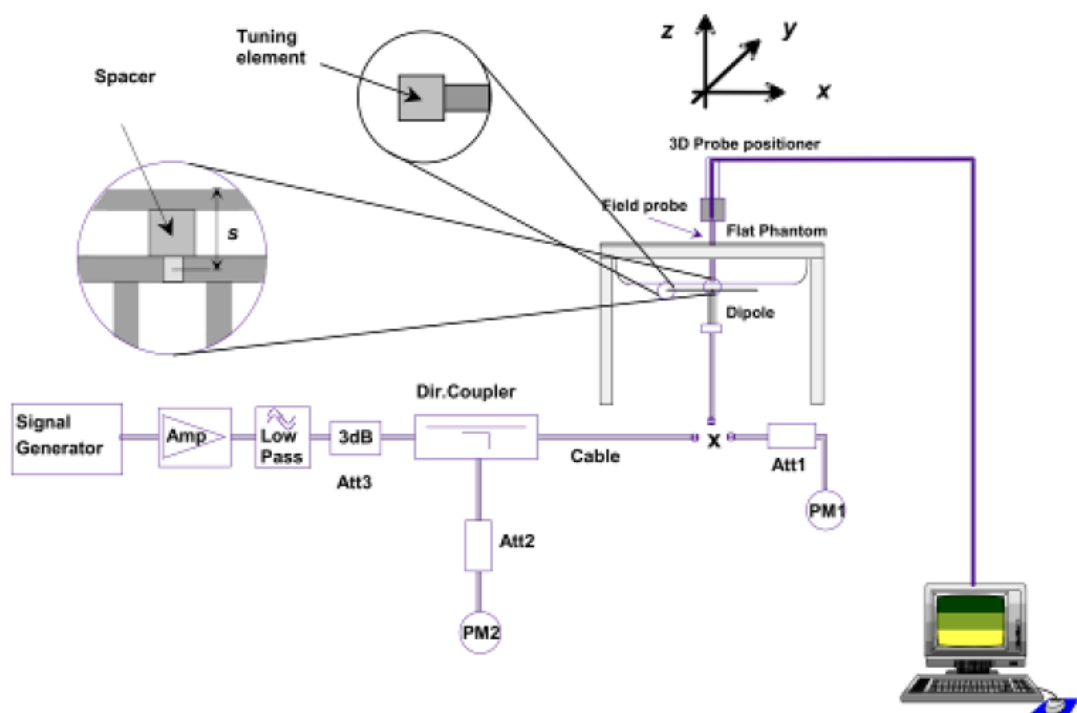

System Verification Setup Block Diagram



Setup Photo of Dipole Antenna

The output power on dipole port must be calibrated to 24 dBm(250 mW) before dipole is connected.

6.3 Validation Results

Comparing to the original SAR value provided by SATIMO, the validation data should be within its specification of 10 %. Table 6.1 shows the target SAR and measured SAR after normalized to 1W input power. The table below indicates the system performance check can meet the variation criterion.

Frequency MHz	Targeted SAR _{1g} (W/kg)	Measured SAR _{1g} (W/kg)	Normalized SAR _{1g} (W/kg)	Tolerance (%)	Date
Head					
750	8.40	2.16	8.64	2.86	2019-08-12
835	9.67	2.41	9.64	-0.31	2019-08-12
1800	38.51	9.61	38.44	-0.18	2019-08-13
1900	39.58	9.91	39.64	0.15	2019-08-13
Body					
750	8.40	2.12	8.48	0.95	2019-08-12
835	9.38	2.35	9.4	0.21	2019-08-12
1800	38.31	9.58	38.32	0.03	2019-08-13
1900	39.10	9.78	39.12	0.05	2019-08-13

Remark: Referring to IEEE 1528-2013, Section 8.2, The system check shall be performed at a test frequency that is within $\pm 10\%$ or ± 100 MHz of the compliance test mid-band frequency, so the 1750 MHz system verification is made of 1800MHz Dipole.

Targeted and Measurement SAR

Please refer to Annex A for the plots of system performance check.

7. EUT Testing Position

7.1 EUT Antenna Position



Block Diagram for EUT Antenna Position

7.2 EUT Testing Position

Body/ Front-of-face mode SAR assessments are required for this device. This EUT was tested in different positions for different SAR test modes, more information as below:

Body SAR tests, Test distance: 0mm		
Antennas	Front	Back
WWAN	No	Yes

Front-of-face SAR tests, Test distance: 25mm		
Antennas	Front	Back
WWAN	Yes	No

Remark:

1. Referring to KDB 447498 D01 v06, A test separation distance of 25mm must be applied for in-front-of the face SAR test exclusion and SAR measurement .
- 2 With body worn SAR, the belt-clip is used for body worn operation with only back side position of the device which is touching the body, so body worn SAR for only back side position is performed.
3. The typical use of the product would be the front of the device to the face.
4. The EUT is not a typical of PTT devices, which is supports 2G/3G/4G network communication, so PTT duty cycle correction is not need.
5. Referring to KDB 447498 D01 v06 , All body-worn accessories containing metallic components, either supplied with the product or available as an option from the device manufacturer, must be tested in conjunction with the host device to demonstrate compliance, So tested with belt clip when evaluating body-worn SAR.
6. RF energy will be generated only when the radio is transmitting.
7. The EUT must be 2.5cm away from human face when transmitting. With body worn SAR, the typical use of the products is with the belt clip, and the belt clip t is not to remove. So tested with belt clip when evaluating body-worn SAR.

Please refer to Annex D for the EUT test setup photos.

8. SAR Measurement Procedures

8.1 Measurement Procedures

The measurement procedures are as follows:

- (a) Use base station simulator (if applicable) or engineering software to transmit RF power continuously (continuous Tx) in the highest power channel.
- (b) Keep EUT to radiate maximum output power or 100% factor (if applicable)
- (c) Measure output power through RF cable and power meter.
- (d) Place the EUT in the positions as Annex D demonstrates.
- (e) Set scan area, grid size and other setting on the SATIMO software.
- (f) Measure SAR results for the highest power channel on each testing position.
- (g) Find out the largest SAR result on these testing positions of each band
- (h) Measure SAR results for other channels in worst SAR testing position if the SAR of highest power channel is larger than 0.8 W/kg

According to the test standard, the recommended procedure for assessing the peak spatial-average SAR value consists of the following steps:

- (a) Power reference measurement
- (b) Area scan
- (c) Zoom scan
- (d) Power drift measurement

8.2 Spatial Peak SAR Evaluation

The procedure for spatial peak SAR evaluation has been implemented according to the test standard. It can be conducted for 1g and 10g, as well as for user-specific masses. The SATIMO software includes all numerical procedures necessary to evaluate the spatial peak SAR value.

The base for the evaluation is a "cube" measurement. The measured volume must include the 1g and 10g cubes with the highest averaged SAR values. For that purpose, the center of the measured volume is aligned to the interpolated peak SAR value of a previously performed area scan.

The entire evaluation of the spatial peak values is performed within the post-processing engine. The system always gives the maximum values for the 1g and 10g cubes. The algorithm to find the cube with highest averaged SAR is divided into the following stages:

- (a) Extraction of the measured data (grid and values) from the Zoom Scan
- (b) Calculation of the SAR value at every measurement point based on all stored data
- (c) Generation of a high-resolution mesh within the measured volume
- (d) Interpolation of all measured values from the measurement grid to the high-resolution grid
- (e) Extrapolation of the entire 3D field distribution to the phantom surface over the distance from sensor to surface
- (f) Calculation of the averaged SAR within masses of 1g and 10g

8.3 Area & Zoom Scan Procedures

First Area Scan is used to locate the approximate location(s) of the local peak SAR value(s). The measurement grid within an Area Scan is defined by the grid extent, grid step size and grid offset. Next, in order to determine the EM field distribution in a three-dimensional spatial extension, Zoom Scan is required. The Zoom Scan measures 5x5x7 points with step size 8, 8 and 5 mm for 300 MHz to 3 GHz, and 8x8x8 points with step size 4, 4 and 2.5 mm for 3 GHz to 6 GHz. The Zoom Scan is performed around the highest E-field value to determine the averaged SAR-distribution over 10 g.

8.4 Volume Scan Procedures

The volume scan is used for assess overlapping SAR distributions for antennas transmitting in different frequency bands. It is equivalent to an oversized zoom scan used in standalone measurements. The measurement volume will be used to enclose all the simultaneous transmitting antennas. For antennas transmitting simultaneously in different frequency bands, the volume scan is measured separately in each frequency band. In order to sum correctly to compute the 1g aggregate SAR, the EUT remain in the same test position for all measurements and all volume scan use the same spatial resolution and grid spacing (step-size is 4, 4 and 2.5 mm). When all volume scan were completed, the software can combine and subsequently superpose these measurement data to calculating the multiband SAR.

8.5 SAR Averaged Methods

The local SAR inside the phantom is measured using small dipole sensing elements inside a probe body. The probe tip must not be in contact with the phantom surface in order to minimize measurements errors, but the highest local SAR will occur at the surface of the phantom.

An extrapolation is using to determinate this highest local SAR values. The extrapolation is based on a fourth-order least-square polynomial fit of measured data. The local SAR value is then extrapolated from the liquid surface with a 1mm step.

The measurements have to be performed over a limited time (due to the duration of the battery) so the step of measurement is high. It could vary between 5 and 8 mm. To obtain an accurate assessment of the maximum SAR averaged over 10g and 1 g requires a very fine resolution in the three dimensional scanned data array.

8.6 Power Drift Monitoring

All SAR testing is under the EUT install full charged battery and transmit maximum output power. In SATIMO measurement software, the power reference measurement and power drift measurement procedures are used for monitoring the power drift of EUT during SAR test. Both these procedures measure the field at a specified reference position before and after the SAR testing. The software will calculate the field difference in dB. If the power drift more than 5%, the SAR will be retested.

9. SAR Test Result

9.1 Conducted RF Output Power

WCDMA - Average Power (dBm)								
Band	WCDMA Band II				WCDMA Band V			
Channel	9262	9400	9538	Tune-up power (dBm)	4132	4183	4233	Tune-up power (dBm)
Frequency (MHz)	1852.4	1880.0	1907.6		826.4	836.6	846.6	
RMC 12.2k	21.50	21.75	22.10	22.5	22.71	22.86	22.74	23.0
HSDPA Subtest-1	21.42	21.73	21.50	22.0	20.43	20.34	20.67	21.0
HSDPA Subtest-2	21.41	21.72	21.48	22.0	20.39	20.31	20.63	21.0
HSDPA Subtest-3	21.39	21.71	21.47	22.0	20.37	20.32	20.64	21.0
HSDPA Subtest-4	21.38	21.72	21.47	22.0	20.41	20.32	20.65	21.0
HSUPA Subtest-1	20.91	20.89	21.81	22.0	21.04	21.25	21.06	21.5
HSUPA Subtest-2	20.89	20.86	21.78	22.0	21.02	21.23	21.05	21.5
HSUPA Subtest-3	20.88	20.87	21.79	22.0	21.02	21.24	21.05	21.5
HSUPA Subtest-4	20.9	20.87	21.78	22.0	21.03	21.24	21.05	21.5
HSUPA Subtest-5	20.9	20.85	21.78	22.0	21.03	21.23	21.03	21.5

Remark:

1. Per KDB 941225 D01 v03, The 12.2kbps RMC mode was selected for SAR testing(the primary mode).
2. When the maximum output power and tune-up tolerance specified for production units in a secondary mode is $\leq 1/4$ dB higher than the primary mode or when the highest reported SAR of the primary mode is scaled by the ratio of specified maximum output power and tune-up tolerance of secondary to primary mode and the adjusted SAR is ≤ 1.2 W/kg, SAR measurement is not required for the secondary mode

FDD-LTE Band 2:

Channel Bandwidth: 1.4 MHz					
Modulation	Channel	RB Configuration		Average Power [dBm]	MPR (dB)
		Size	Offset		
QPSK	LCH	1	0	24.10	0
		1	3	24.08	0
		1	5	24.12	0
		3	0	23.21	0
		3	2	23.16	0
		3	3	23.19	0
		6	0	23.16	1
	MCH	1	0	24.03	0
		1	3	24.01	0
		1	5	24.00	0
		3	0	23.16	0
		3	2	23.13	0
		3	3	23.14	0
		6	0	23.07	1
	HCH	1	0	23.50	0
		1	3	23.49	0
		1	5	23.49	0
		3	0	23.31	0
		3	2	23.33	0
		3	3	23.36	0
		6	0	22.52	1
16QAM	LCH	1	0	23.47	1
		1	3	23.50	1
		1	5	23.48	1
		3	0	23.21	1
		3	2	23.18	1
		3	3	23.20	1
		6	0	22.12	2
	MCH	1	0	23.33	1
		1	3	23.39	1
		1	5	23.31	1
		3	0	23.33	1
		3	2	23.25	1
		3	3	23.27	1
		6	0	22.10	2
HCH	1	0	22.83	1	
	1	3	22.86	1	

		1	5	22.80	1
		3	0	22.62	1
		3	2	22.56	1
		3	3	22.60	1
		6	0	21.50	2

Channel Bandwidth: 3 MHz					
Modulation	Channel	RB Configuration		Average Power [dBm]	MPR (dB)
		Size	Offset		
QPSK	LCH	1	0	24.07	0
		1	7	24.14	0
		1	14	24.11	0
		8	0	23.22	1
		8	4	23.23	1
		8	7	23.25	1
		15	0	23.23	1
	MCH	1	0	24.04	0
		1	7	24.10	0
		1	14	24.02	0
		8	0	23.11	1
		8	4	23.10	1
		8	7	23.12	1
		15	0	23.12	1
	HCH	1	0	23.48	0
		1	7	23.44	0
		1	14	23.47	0
		8	0	22.61	1
		8	4	22.59	1
		8	7	22.59	1
		15	0	22.59	1
16QAM	LCH	1	0	23.36	1
		1	7	23.40	1
		1	14	23.39	1
		8	0	22.27	2
		8	4	22.29	2
		8	7	22.27	2
		15	0	22.21	2
	MCH	1	0	23.48	1
		1	7	23.48	1
		1	14	23.45	1
		8	0	22.19	2
		8	4	22.15	2
		8	7	22.16	2

	HCH	15	0	22.19	2
		1	0	22.72	1
		1	7	22.75	1
		1	14	22.69	1
		8	0	21.56	2
		8	4	21.53	2
		8	7	21.55	2
		15	0	21.61	2

Channel Bandwidth: 5 MHz					
Modulation	Channel	RB Configuration		Average Power [dBm]	MPR (dB)
		Size	Offset		
QPSK	LCH	1	0	24.26	0
		1	12	24.28	0
		1	24	24.24	0
		12	0	23.30	1
		12	6	23.31	1
		12	13	23.32	1
		25	0	23.27	1
	MCH	1	0	24.19	0
		1	12	24.11	0
		1	24	24.08	0
		12	0	23.21	1
		12	6	23.10	1
		12	13	23.20	1
		25	0	23.18	1
	HCH	1	0	23.67	0
		1	12	23.53	0
		1	24	23.54	0
		12	0	22.70	1
		12	6	22.63	1
		12	13	22.63	1
		25	0	22.61	1
16QAM	LCH	1	0	23.48	1
		1	12	23.50	1
		1	24	23.49	1
		12	0	22.35	2
		12	6	22.33	2
		12	13	22.36	2
		25	0	22.27	2
	MCH	1	0	23.49	1
		1	12	23.41	1
		1	24	23.39	1

		12	0	22.37	2
		12	6	22.27	2
		12	13	22.36	2
		25	0	22.24	2
	HCH	1	0	22.82	1
		1	12	22.72	1
		1	24	22.71	1
		12	0	21.72	2
		12	6	21.68	2
		12	13	21.66	2
		25	0	21.70	2

Channel Bandwidth: 10 MHz					
Modulation	Channel	RB Configuration		Average Power [dBm]	MPR (dB)
		Size	Offset		
QPSK	LCH	1	0	24.19	0
		1	24	24.24	0
		1	49	24.19	0
		25	0	23.30	1
		25	12	23.30	1
		25	25	23.32	1
		50	0	23.29	1
	MCH	1	0	24.03	0
		1	24	24.04	0
		1	49	23.80	0
		25	0	23.11	1
		25	12	23.10	1
		25	25	23.06	1
		50	0	23.08	1
	HCH	1	0	23.72	0
		1	24	23.58	0
		1	49	23.25	0
		25	0	22.74	1
		25	12	22.67	1
		25	25	22.61	1
		50	0	22.69	1
16QAM	LCH	1	0	23.48	1
		1	24	23.43	1
		1	49	23.49	1
		25	0	22.28	2
		25	12	22.28	2
		25	25	22.29	2
		50	0	22.28	2

	MCH	1	0	23.44	1
		1	24	23.49	1
		1	49	23.29	1
		25	0	22.19	2
		25	12	22.19	2
		25	25	22.15	2
		50	0	22.18	2
	HCH	1	0	22.95	1
		1	24	22.85	1
		1	49	22.69	1
		25	0	21.72	2
		25	12	21.70	2
		25	25	21.66	2
		50	0	21.75	2

Channel Bandwidth: 15 MHz					
Modulation	Channel	RB Configuration		Average Power [dBm]	MPR (dB)
		Size	Offset		
QPSK	LCH	1	0	24.22	0
		1	37	24.24	0
		1	74	24.17	0
		37	0	23.39	1
		37	18	23.40	1
		37	38	23.40	1
		75	0	23.40	1
	MCH	1	0	24.22	0
		1	37	24.00	0
		1	74	24.01	0
		37	0	23.19	1
		37	18	23.13	1
		37	38	23.11	1
		75	0	23.16	1
	HCH	1	0	23.89	0
		1	37	23.66	0
		1	74	23.47	0
		37	0	22.91	1
		37	18	22.83	1
		37	38	22.72	1
		75	0	22.84	1
16QAM	LCH	1	0	23.50	1
		1	37	23.42	1
		1	74	23.46	1
		37	0	22.31	2

		37	18	22.33	2
		37	38	22.31	2
		75	0	22.34	2
	MCH	1	0	23.48	1
		1	37	23.38	1
		1	74	23.34	1
		37	0	22.25	2
		37	18	22.21	2
		37	38	22.21	2
		75	0	22.22	2
	HCH	1	0	23.10	1
		1	37	22.91	1
		1	74	22.80	1
		37	0	21.85	2
37		18	21.79	2	
37		38	21.71	2	
75		0	21.81	2	

Channel Bandwidth: 20 MHz					
Modulation	Channel	RB Configuration		Average Power [dBm]	MPR (dB)
		Size	Offset		
QPSK	LCH	1	0	24.38	0
		1	49	24.35	0
		1	99	24.30	0
		50	0	23.46	1
		50	25	23.35	1
		50	50	23.41	1
		100	0	23.34	1
	MCH	1	0	24.38	0
		1	49	24.13	0
		1	99	24.07	0
		50	0	23.24	1
		50	25	23.10	1
		50	50	23.09	1
		100	0	23.16	1
	HCH	1	0	23.93	0
		1	49	23.65	0
		1	99	23.34	0
		50	0	22.91	1
		50	25	22.82	1
		50	50	22.72	1
		100	0	22.87	1
16QAM	LCH	1	0	23.45	1

		1	49	23.41	1
		1	99	23.49	1
		50	0	22.33	2
		50	25	22.29	2
		50	50	22.28	2
		100	0	22.32	2
	MCH	1	0	23.42	1
		1	49	23.41	1
		1	99	23.41	1
		50	0	22.29	2
		50	25	22.21	2
		50	50	22.25	2
	HCH	100	0	22.23	2
		1	0	23.24	1
		1	49	22.94	1
		1	99	22.77	1
		50	0	21.98	2
		50	25	21.82	2
		50	50	21.75	2
	100	0	21.87	2	

FDD-LTE Band 4:

Channel Bandwidth: 1.4 MHz						
Modulation	Channel	RB Configuration		Average Power [dBm]	MPR (dB)	
		Size	Offset			
QPSK	LCH	1	0	24.48	0	
		1	3	24.44	0	
		1	5	24.47	0	
		3	0	23.42	0	
		3	2	23.39	0	
		3	3	23.4	0	
		6	0	23.48	1	
	MCH	1	0	24.43	0	
		1	3	24.40	0	
		1	5	24.44	0	
		3	0	23.44	0	
		3	2	23.38	0	
		3	3	23.38	0	
	HCH	6	0	23.43	1	
		1	0	24.07	0	
			1	3	24.01	0

		1	5	24.06	0
		3	0	23.95	0
		3	2	23.92	0
		3	3	23.92	0
		6	0	22.97	1
16QAM	LCH	1	0	23.57	1
		1	3	23.61	1
		1	5	23.59	1
		3	0	23.51	1
		3	2	23.44	1
		3	3	23.45	1
		6	0	22.37	2
	MCH	1	0	23.56	1
		1	3	23.61	1
		1	5	23.59	1
		3	0	23.37	1
		3	2	23.32	1
		3	3	23.35	1
		6	0	22.46	2
	HCH	1	0	23.09	1
		1	3	23.11	1
		1	5	23.08	1
		3	0	22.99	1
		3	2	22.94	1
		3	3	22.93	1
		6	0	21.89	2

Channel Bandwidth: 3 MHz					
Modulation	Channel	RB Configuration		Average Power [dBm]	MPR (dB)
		Size	Offset		
QPSK	LCH	1	0	24.39	0
		1	7	24.43	0
		1	14	24.41	0
		8	0	23.47	1
		8	4	23.48	1
		8	7	23.47	1
		15	0	23.45	1
	MCH	1	0	24.44	0
		1	7	24.48	0
		1	14	24.40	0
		8	0	23.40	1
		8	4	23.41	1
		8	7	23.41	1

	HCH	15	0	23.34	1
		1	0	24.03	0
		1	7	23.97	0
		1	14	23.93	0
		8	0	23.00	1
		8	4	22.98	1
		8	7	22.98	1
		15	0	22.97	1
16QAM	LCH	1	0	23.55	1
		1	7	23.60	1
		1	14	23.58	1
		8	0	22.48	2
		8	4	22.52	2
		8	7	22.48	2
		15	0	22.37	2
	MCH	1	0	23.61	1
		1	7	23.64	1
		1	14	23.61	1
		8	0	22.37	1
		8	4	22.34	2
		8	7	22.36	2
		15	0	22.31	2
	HCH	1	0	23.21	2
		1	7	23.17	1
		1	14	23.08	1
		8	0	21.94	1
		8	4	21.90	1
		8	7	21.91	2
		15	0	21.96	2

Channel Bandwidth: 5 MHz					
Modulation	Channel	RB Configuration		Average Power [dBm]	MPR (dB)
		Size	Offset		
QPSK	LCH	1	0	24.53	0
		1	12	24.52	0
		1	24	24.45	0
		12	0	23.49	1
		12	6	23.48	1
		12	13	23.48	1
		25	0	23.44	1
	MCH	1	0	24.51	0
		1	12	24.47	0
		1	24	24.43	0

		12	0	23.41	1	
		12	6	23.42	1	
		12	13	23.40	1	
		25	0	23.35	1	
	HCH	1	0	24.23	0	
		1	12	24.13	0	
		1	24	24.04	0	
		12	0	23.10	1	
		12	6	23.07	1	
		12	13	23.03	1	
		25	0	23.00	1	
	16QAM	LCH	1	0	23.65	1
			1	12	23.68	1
1			24	23.60	1	
12			0	22.49	2	
12			6	22.47	2	
12			13	22.46	2	
25			0	22.39	2	
MCH		1	0	23.61	1	
		1	12	23.61	1	
		1	24	23.55	1	
		12	0	22.48	2	
		12	6	22.47	2	
		12	13	22.47	2	
		25	0	22.34	2	
HCH		1	0	23.35	1	
		1	12	23.24	1	
		1	24	23.13	1	
		12	0	22.09	2	
		12	6	22.06	2	
		12	13	22.01	2	
		25	0	22.03	2	

Channel Bandwidth: 10 MHz					
Modulation	Channel	RB Configuration		Average Power [dBm]	MPR (dB)
		Size	Offset		
QPSK	LCH	1	0	24.40	0
		1	24	24.50	0
		1	49	24.47	0
		25	0	23.46	1
		25	12	23.48	1
		25	25	23.44	1
		50	0	23.45	1
	MCH	1	0	24.50	0
		1	24	24.50	0
		1	49	24.05	0
		25	0	23.39	1
		25	12	23.38	1
		25	25	23.36	1
		50	0	23.34	1
	HCH	1	0	23.98	0
		1	24	24.17	0
		1	49	23.99	0
		25	0	23.16	1
		25	12	23.11	1
		25	25	23.02	1
		50	0	23.09	1
16QAM	LCH	1	0	23.68	1
		1	24	23.64	1
		1	49	23.61	1
		25	0	22.42	2
		25	12	22.42	2
		25	25	22.40	2
		50	0	22.40	2
	MCH	1	0	23.72	1
		1	24	23.73	1
		1	49	23.60	1
		25	0	22.38	2
		25	12	22.37	2
		25	25	22.35	2
		50	0	22.36	2
	HCH	1	0	23.30	1
		1	24	23.38	1
		1	49	23.16	1
		25	0	22.16	2

		25	12	22.09	2
		25	25	22.02	2
		50	0	22.13	2

Channel Bandwidth: 15 MHz					
Modulation	Channel	RB Configuration		Average Power [dBm]	MPR (dB)
		Size	Offset		
QPSK	LCH	1	0	24.55	0
		1	37	24.49	0
		1	74	24.46	0
		37	0	23.59	1
		37	18	23.58	1
		37	38	23.59	1
		75	0	23.58	1
	MCH	1	0	24.57	0
		1	37	24.49	0
		1	74	24.16	0
		37	0	23.50	1
		37	18	23.50	1
		37	38	23.46	1
		75	0	23.48	1
	HCH	1	0	23.71	0
		1	37	24.12	0
		1	74	24.02	0
		37	0	23.10	1
		37	18	23.27	1
		37	38	23.16	1
		75	0	23.24	1
16QAM	LCH	1	0	23.72	1
		1	37	23.66	1
		1	74	23.55	1
		37	0	22.50	2
		37	18	22.48	2
		37	38	22.49	2
		75	0	22.49	2
	MCH	1	0	23.68	1
		1	37	23.65	1
		1	74	23.49	1
		37	0	22.46	2
		37	18	22.46	2
		37	38	22.42	2
		75	0	22.42	2
HCH	1	0	23.06	1	

		1	37	23.44	1
		1	74	23.18	1
		37	0	22.16	2
		37	18	22.21	2
		37	38	22.13	2
		75	0	22.21	2

Channel Bandwidth: 20 MHz					
Modulation	Channel	RB Configuration		Average Power [dBm]	MPR (dB)
		Size	Offset		
QPSK	LCH	1	0	24.67	0
		1	49	24.59	0
		1	99	24.58	0
		50	0	23.95	1
		50	25	23.98	1
		50	50	23.88	1
		100	0	23.46	1
	MCH	1	0	24.66	0
		1	49	24.57	0
		1	99	24.00	0
		50	0	23.41	1
		50	25	23.37	1
		50	50	23.32	1
		100	0	23.37	1
	HCH	1	0	23.97	0
		1	49	23.96	0
		1	99	24.02	0
		50	0	22.99	1
		50	25	23.15	1
		50	50	23.11	1
		100	0	23.24	1
16QAM	LCH	1	0	23.79	1
		1	49	23.71	1
		1	99	23.64	1
		50	0	22.42	2
		50	25	22.39	2
		50	50	22.34	2
		100	0	22.39	2
	MCH	1	0	23.77	1
		1	49	23.71	1
		1	99	23.44	1
		50	0	22.44	2
		50	25	22.40	2

		50	50	22.35	2
		100	0	22.36	2
	HCH	1	0	23.35	1
		1	49	23.35	1
		1	99	23.16	1
		50	0	22.09	2
		50	25	22.21	2
		50	50	22.12	2
		100	0	22.23	2

FDD-LTE Band 5:

Channel Bandwidth: 1.4 MHz					
Modulation	Channel	RB Configuration		Average Power [dBm]	MPR (dB)
		Size	Offset		
QPSK	LCH	1	0	22.55	0
		1	3	22.54	0
		1	5	22.59	0
		3	0	22.26	0
		3	2	22.24	0
		3	3	22.23	0
		6	0	21.64	1
	MCH	1	0	23.03	0
		1	3	23.01	0
		1	5	23.03	0
		3	0	22.36	0
		3	2	22.26	0
		3	3	22.33	0
		6	0	21.99	1
	HCH	1	0	23.18	0
		1	3	23.18	0
		1	5	23.16	0
		3	0	22.22	0
		3	2	22.19	0
		3	3	22.18	0
		6	0	22.13	1
16QAM	LCH	1	0	21.7	1
		1	3	21.75	1
		1	5	21.74	1
		3	0	21.64	1
		3	2	21.59	1
		3	3	21.58	1
		6	0	21.5	2

	MCH	1	0	22.39	1
		1	3	22.42	1
		1	5	22.41	1
		3	0	22.06	1
		3	2	22.01	1
		3	3	22.08	1
		6	0	21.46	2
	HCH	1	0	22.42	1
		1	3	22.47	1
		1	5	22.41	1
		3	0	22.25	1
		3	2	22.21	1
		3	3	22.24	1
		6	0	21.27	2

Channel Bandwidth: 3 MHz					
Modulation	Channel	RB Configuration		Average Power [dBm]	MPR (dB)
		Size	Offset		
QPSK	LCH	1	0	22.44	0
		1	7	22.54	0
		1	14	22.56	0
		8	0	21.63	1
		8	4	21.65	1
		8	7	21.68	1
		15	0	21.59	1
	MCH	1	0	22.98	0
		1	7	23.03	0
		1	14	22.97	0
		8	0	22.05	1
		8	4	22.02	1
		8	7	22.05	1
		15	0	22.03	1
	HCH	1	0	23.19	0
		1	7	23.21	0
		1	14	23.14	0
		8	0	22.19	1
		8	4	22.17	1
		8	7	22.17	1
		15	0	22.16	1
16QAM	LCH	1	0	21.69	1
		1	7	21.79	1
		1	14	21.8	1
		8	0	20.66	2

		8	4	20.68	2
		8	7	20.69	2
		15	0	20.51	2
	MCH	1	0	22.37	1
		1	7	22.40	1
		1	14	22.36	1
		8	0	21.06	2
		8	4	21.02	2
		8	7	21.07	2
		15	0	21.02	2
	HCH	1	0	22.41	1
		1	7	22.45	1
		1	14	22.39	1
		8	0	21.17	2
		8	4	21.14	2
8		7	21.14	2	
15		0	21.17	2	

Channel Bandwidth: 5 MHz					
Modulation	Channel	RB Configuration		Average Power [dBm]	MPR (dB)
		Size	Offset		
QPSK	LCH	1	0	22.63	0
		1	12	22.73	0
		1	24	22.81	0
		12	0	21.68	1
		12	6	21.71	1
		12	13	21.79	1
		25	0	21.65	1
	MCH	1	0	23.11	0
		1	12	23.14	0
		1	24	23.09	0
		12	0	22.12	1
		12	6	22.11	1
		12	13	22.11	1
		25	0	22.09	1
	HCH	1	0	23.32	0
		1	12	23.14	0
		1	24	23.25	0
		12	0	22.28	1
		12	6	22.24	1
		12	13	22.24	1
		25	0	22.34	1
16QAM	LCH	1	0	21.83	1

		1	12	21.91	1
		1	24	22.04	1
		12	0	20.67	2
		12	6	20.70	2
		12	13	20.82	2
		25	0	20.63	2
	MCH	1	0	22.40	1
		1	12	22.41	1
		1	24	22.33	1
		12	0	21.22	2
		12	6	21.20	2
		12	13	21.25	2
	HCH	25	0	21.10	2
		1	0	22.44	1
		1	12	22.37	1
		1	24	22.42	1
		12	0	21.26	2
		12	6	21.26	2
		12	13	21.23	2
	25	0	21.24	2	

Channel Bandwidth: 10 MHz					
Modulation	Channel	RB Configuration		Average Power [dBm]	MPR (dB)
		Size	Offset		
QPSK	LCH	1	0	22.58	0
		1	24	22.80	0
		1	49	22.88	0
		25	0	21.68	1
		25	12	21.82	1
		25	25	21.71	1
		50	0	21.84	1
	MCH	1	0	22.98	0
		1	24	23.05	0
		1	49	23.38	0
		25	0	22.36	1
		25	12	22.38	1
		25	25	22.32	1
		50	0	22.07	1
	HCH	1	0	23.19	0
		1	24	23.24	0
		1	49	23.21	0
		25	0	22.21	1
		25	12	22.21	1

		25	25	22.25	1
		50	0	22.20	1
16QAM	LCH	1	0	21.83	1
		1	24	22.09	1
		1	49	22.29	1
		25	0	20.70	2
		25	12	20.84	2
		25	25	20.90	2
		50	0	20.80	2
		MCH	1	0	22.41
	1		24	22.48	1
	1		49	22.40	1
	25		0	21.09	2
	25		12	21.10	2
	25		25	21.13	2
	50		0	21.12	2
	HCH	1	0	22.39	1
		1	24	22.43	1
		1	49	22.49	1
		25	0	21.15	2
		25	12	21.17	2
		25	25	21.23	2
		50	0	21.21	2

FDD-LTE Band 12:

Channel Bandwidth: 1.4 MHz					
Modulation	Channel	RB Configuration		Average Power [dBm]	MPR (dB)
		Size	Offset		
QPSK	LCH	1	0	22.86	0
		1	3	22.92	0
		1	5	22.95	0
		3	0	22.43	0
		3	2	22.47	0
		3	3	22.46	0
		6	0	21.92	1
	MCH	1	0	21.53	0
		1	3	21.58	0
		1	5	21.69	0
		3	0	21.51	0
		3	2	21.75	0
		3	3	21.86	0
		6	0	20.61	1
	HCH	1	0	22.03	0
		1	3	22.04	0
		1	5	22.03	0
		3	0	22.08	0
		3	2	22.01	0
		3	3	22.03	0
		6	0	21.07	1
16QAM	LCH	1	0	22.12	1
		1	3	22.26	1
		1	5	22.22	1
		3	0	22.10	1
		3	2	22.09	1
		3	3	22.09	1
		6	0	20.86	2
	MCH	1	0	20.83	1
		1	3	20.84	1
		1	5	21.13	1
		3	0	20.58	1
		3	2	20.59	1
		3	3	20.52	1
		6	0	20.39	2
HCH	1	0	21.30	1	
	1	3	21.38	1	

		1	5	21.33	1
		3	0	21.11	1
		3	2	21.07	1
		3	3	21.11	1
		6	0	21.17	2

Channel Bandwidth: 3 MHz					
Modulation	Channel	RB Configuration		Average Power [dBm]	MPR (dB)
		Size	Offset		
QPSK	LCH	1	0	22.82	0
		1	7	23.03	0
		1	14	23.12	0
		8	0	22.00	1
		8	4	22.08	1
		8	7	22.15	1
		15	0	22.03	1
	MCH	1	0	21.54	0
		1	7	21.57	0
		1	14	21.95	0
		8	0	21.17	1
		8	4	21.30	1
		8	7	21.55	1
		15	0	21.32	1
	HCH	1	0	22.20	0
		1	7	22.04	0
		1	14	21.97	0
		8	0	21.18	1
		8	4	21.09	1
		8	7	21.07	1
		15	0	21.15	1
16QAM	LCH	1	0	22.13	1
		1	7	22.35	1
		1	14	22.34	1
		8	0	21.06	2
		8	4	21.14	2
		8	7	21.16	2
		15	0	21.00	2
	MCH	1	0	21.70	1
		1	7	21.66	1
		1	14	21.41	1
		8	0	21.27	2
		8	4	21.40	2
		8	7	21.47	2

	HCH	15	0	21.41	2
		1	0	21.45	1
		1	7	21.30	1
		1	14	21.27	1
		8	0	21.12	2
		8	4	21.04	2
		8	7	21.01	2
		15	0	21.13	2

Channel Bandwidth: 5 MHz					
Modulation	Channel	RB Configuration		Average Power [dBm]	MPR (dB)
		Size	Offset		
QPSK	LCH	1	0	22.98	0
		1	12	23.24	0
		1	24	22.69	0
		12	0	22.09	1
		12	6	22.17	1
		12	13	22.30	1
		25	0	22.09	1
	MCH	1	0	21.52	0
		1	12	21.53	0
		1	24	23.01	0
		12	0	21.83	1
		12	6	21.86	1
		12	13	20.76	1
		25	0	21.25	1
	HCH	1	0	22.73	0
		1	12	22.27	0
		1	24	22.05	0
		12	0	21.48	1
		12	6	21.32	1
		12	13	21.16	1
		25	0	21.42	1
16QAM	LCH	1	0	22.25	1
		1	12	22.43	1
		1	24	22.07	1
		12	0	21.14	2
		12	6	21.18	2
		12	13	21.29	2
		25	0	21.09	2
	MCH	1	0	20.76	1
		1	12	20.55	1
		1	24	22.30	1

		12	0	21.04	2
		12	6	21.08	2
		12	13	21.44	2
		25	0	21.34	2
	HCH	1	0	21.90	1
		1	12	21.41	1
		1	24	21.26	1
		12	0	21.43	2
		12	6	21.25	2
		12	13	21.11	2
		25	0	21.35	2

Channel Bandwidth: 10 MHz					
Modulation	Channel	RB Configuration		Average Power [dBm]	MPR (dB)
		Size	Offset		
QPSK	LCH	1	0	22.92	0
		1	24	21.88	0
		1	49	21.51	0
		25	0	22.05	1
		25	12	21.66	1
		25	25	21.12	1
		50	0	22.03	1
	MCH	1	0	23.27	0
		1	24	21.87	0
		1	49	22.49	0
		25	0	22.47	1
		25	12	22.48	1
		25	25	22.37	1
		50	0	21.60	1
	HCH	1	0	21.99	0
		1	24	22.77	0
		1	49	22.02	0
		25	0	21.25	1
		25	12	21.63	1
		25	25	21.40	1
		50	0	21.65	1
16QAM	LCH	1	0	22.24	1
		1	24	21.24	1
		1	49	20.78	1
		25	0	21.10	2
		25	12	20.89	2
		25	25	21.27	2
		50	0	20.95	2

	MCH	1	0	22.42	1
		1	24	21.37	1
		1	49	21.91	1
		25	0	21.44	2
		25	12	21.30	2
		25	25	20.83	2
		50	0	20.70	2
	HCH	1	0	21.39	1
		1	24	22.04	1
		1	49	21.31	1
		25	0	21.37	2
		25	12	21.49	2
		25	25	21.32	2
		50	0	21.45	2

FDD-LTE Band 17:

Channel Bandwidth: 5 MHz					
Modulation	Channel	RB Configuration		Average Power [dBm]	MPR (dB)
		Size	Offset		
QPSK	LCH	1	0	23.13	0
		1	12	22.27	0
		1	24	22.93	0
		12	0	21.51	1
		12	6	20.85	1
		12	13	20.93	1
		25	0	21.04	1
	MCH	1	0	22.32	0
		1	12	22.93	0
		1	24	22.31	0
		12	0	21.51	1
		12	6	21.78	1
		12	13	21.54	1
		25	0	21.68	1
	HCH	1	0	22.59	0
		1	12	22.23	0
		1	24	22.02	0
		12	0	21.30	1
		12	6	21.23	1
		12	13	21.11	1
		25	0	21.30	1
16QAM	LCH	1	0	22.43	1
		1	12	21.32	1
		1	24	22.13	1
		12	0	20.57	2
		12	6	20.34	2
		12	13	20.39	2
		25	0	20.31	2
	MCH	1	0	21.67	1
		1	12	22.18	1
		1	24	21.58	1
		12	0	20.70	2
		12	6	20.87	2
		12	13	20.61	2
		25	0	20.65	2
	HCH	1	0	21.75	1
		1	12	21.39	1
		1	24	21.23	1

		12	0	21.31	2
		12	6	21.16	2
		12	13	21.05	2
		25	0	21.25	2

Channel Bandwidth: 10 MHz					
Modulation	Channel	RB Configuration		Average Power [dBm]	MPR (dB)
		Size	Offset		
QPSK	LCH	1	0	23.15	0
		1	24	22.37	0
		1	49	22.07	0
		25	0	20.92	1
		25	12	21.89	1
		25	25	21.44	1
		50	0	21.71	1
	MCH	1	0	21.93	0
		1	24	22.81	0
		1	49	21.98	0
		25	0	21.02	1
		25	12	21.63	1
		25	25	21.35	1
		50	0	21.59	1
	HCH	1	0	21.69	0
		1	24	22.64	0
		1	49	21.96	0
		25	0	21.73	1
		25	12	21.43	1
		25	25	21.29	1
		50	0	21.50	1
16QAM	LCH	1	0	22.18	1
		1	24	21.74	1
		1	49	21.31	1
		25	0	21.04	2
		25	12	21.36	2
		25	25	21.40	2
		50	0	21.49	2
	MCH	1	0	21.44	1
		1	24	22.22	1
		1	49	21.34	1
		25	0	21.15	2
		25	12	21.46	2
		25	25	21.29	2
		50	0	21.50	2

HCH	1	0	21.08	1
	1	24	21.93	1
	1	49	21.27	1
	25	0	21.47	2
	25	12	21.45	2
	25	25	21.20	2
	50	0	21.44	2

Remark:

- Per KDB941225 D05 v02r05, Start with the largest channel bandwidth then measure SAR for QPSK with 1 RB allocation, using the RB offset and required test channel combination with the highest maximum output power among RB offsets at the upper edge, middle, and lower edge of each required test channel. When the reported SAR is ≤ 0.8 W/kg, testing of the remaining RB offset configurations and required test channels is not required for 1 RB allocation; otherwise, SAR is required for the remaining required test channels and only for the RB offset configuration with the highest output power for that channel. 6 When the reported SAR of a required test channel is > 1.45 W/kg, SAR is required for all three RB offset configurations for that required test channel.
- Per KDB941225 D05 v02r05, The procedures required for 1 RB allocation in 5.2.1 are applied to measure the SAR for QPSK with 50% RB allocation.
- Per KDB941225 D05 v02r05, For QPSK with 100% RB allocation, SAR is not required when the highest maximum output power for 100 % RB allocation is less than the highest maximum output power in 50% and 1 RB allocations, and the highest reported SAR for 1 RB and 50% RB allocation in 5.2.1 and 5.2.2 are ≤ 0.8 W/kg. Otherwise, SAR is measured for the highest output power channel; and if the reported SAR is > 1.45 W/kg, the remaining required test channels must also be tested.
- Per KDB941225 D05 v02r05, For each modulation besides QPSK; e.g., 16-QAM, 64-QAM, apply the QPSK procedures in 5.2.1, 5.2.2, and 5.2.3 to determine the QAM configurations that may need SAR measurement. For each configuration identified as required for testing, SAR is required only when the highest maximum output power for the configuration in the higher order modulation is $> \frac{1}{2}$ dB higher than the same configuration in QPSK or when the reported SAR for the QPSK configuration is > 1.45 W/kg

9.2 Test Results for Standalone SAR Test

Front-of-face SAR

WCDMA Band 2 –Head SAR Test (Gap: 25mm)									
Plot No.	Mode	Test Position Body	Frequency		Output Power (dBm)	Rated Limit (dBm)	Scaling Factor	SAR1g (W/kg)	Scaled SAR1g (W/kg)
			CH.	MHz					
1.	RMC 12.2k	Front side	9538	1907.6	22.10	22.5	1.096	0.116	0.127

WCDMA Band 5 –Head SAR Test (Gap: 25mm)									
Plot No.	Mode	Test Position Body	Frequency		Output Power (dBm)	Rated Limit (dBm)	Scaling Factor	SAR1g (W/kg)	Scaled SAR1g (W/kg)
			CH.	MHz					
2.	RMC 12.2k	Front Side	4183	836.6	22.86	23.0	1.033	0.392	0.405

LTE Band 2–Head SAR Test (Gap: 25mm)									
Plot No.	Mode		Test Position Body	Frequency MHz	Output Power (dBm)	Rated Limit (dBm)	Scaling Factor	SAR1g (W/kg)	Scaled SAR1g (W/kg)
	Modulation, Bandwidth, RB								
3.	QPSK 20MHz 1RB		Front Side	1860.0	24.38	24.5	1.028	0.285	0.293
4.	QPSK 20MHz 50%RB		Front Side	1860.0	24.38	24.5	1.028	0.211	0.217

LTE Band 4–Head SAR Test (Gap: 25mm)									
Plot No.	Mode		Test Position Body	Frequency MHz	Output Power (dBm)	Rated Limit (dBm)	Scaling Factor	SAR1g (W/kg)	Scaled SAR1g (W/kg)
	Modulation, Bandwidth, RB								
5.	QPSK 20MHz 1RB		Front Side	1720.0	24.67	25.0	1.079	0.354	0.382
6.	QPSK 20MHz 50%RB		Front Side	1720.0	24.67	25.0	1.079	0.207	0.223

LTE Band 5–Head SAR Test (Gap: 25mm)									
Plot No.	Mode		Test Position Body	Frequency MHz	Output Power (dBm)	Rated Limit (dBm)	Scaling Factor	SAR1g (W/kg)	Scaled SAR1g (W/kg)
	Modulation, Bandwidth, RB								
7.	QPSK 10MHz 1RB		Front Side	836.5	23.38	23.5	1.028	0.457	0.470
8.	QPSK 10MHz 50%RB		Front Side	836.5	23.38	23.5	1.028	0.233	0.240

LTE Band 12–Head SAR Test (Gap: 25mm)								
Plot No.	Mode	Test Position Body	Frequency	Output Power (dBm)	Rated Limit (dBm)	Scaling Factor	SAR1g (W/kg)	Scaled SAR1g (W/kg)
	Modulation, Bandwidth, RB		MHz					
9.	QPSK 10MHz 1RB	Front Side	707.5	23.27	23.5	1.054	0.593	0.625
10.	QPSK 10MHz 50%RB	Front Side	707.5	23.27	23.5	1.054	0.312	0.329

LTE Band 17–Head SAR Test (Gap: 25mm)								
Plot No.	Mode	Test Position Body	Frequency	Output Power (dBm)	Rated Limit (dBm)	Scaling Factor	SAR1g (W/kg)	Scaled SAR1g (W/kg)
	Modulation, Bandwidth, RB		MHz					
11.	QPSK 10MHz 1RB	Front Side	709.0	23.15	23.5	1.084	0.626	0.679
12.	QPSK 10MHz 50%RB	Front Side	709.0	23.15	23.5	1.084	0.322	0.349

Remark: Per KDB 447498 D01 v06, if the highest output channel SAR for each exposure position ≤ 0.8 W/kg other channels SAR tests are not necessary.

Body SAR

WCDMA Band 2 – Body SAR Test (Gap: 0mm)									
Plot No.	Mode	Test Position Body	Frequency		Output Power (dBm)	Rated Limit (dBm)	Scaling Factor	SAR1g (W/kg)	Scaled SAR1g (W/kg)
			CH.	MHz					
13.	RMC 12.2k	Back Side	9538	1907.6	22.10	22.5	1.096	0.174	0.191

WCDMA Band 5 – Body SAR Test (Gap: 0mm)									
Plot No.	Mode	Test Position Body	Frequency		Output Power (dBm)	Rated Limit (dBm)	Scaling Factor	SAR1g (W/kg)	Scaled SAR1g (W/kg)
			CH.	MHz					
14.	RMC 12.2k	Back Side	4183	836.6	22.86	23.0	1.033	0.927	0.957
15.	RMC 12.2k	Back Side	4132	826.4	22.71	23.0	1.069	0.946	1.011
16.	RMC 12.2k	Back Side	4233	846.6	22.74	23.0	1.062	0.893	0.948

LTE Band 2–Body SAR Test (Gap: 0mm)									
Plot No.	Mode	Test Position Body	Freque	Output Power (dBm)	Rate d Limit (dBm)	Scaling Factor	SAR1g (W/kg)	Scaled SAR1g (W/kg)	
	Modulation, Bandwidth, RB		ncy MHz						
17.	QPSK 20MHz 1RB	Back Side	1860.0	24.38	24.5	1.028	0.347	0.357	
18.	QPSK 20MHz 50%RB	Back Side	1860.0	24.38	24.5	1.028	0.199	0.205	

LTE Band 4–Body SAR Test (Gap: 0mm)									
Plot No.	Mode	Test Position Body	Freque	Output Power (dBm)	Rated Limit (dBm)	Scaling Factor	SAR1g (W/kg)	Scaled SAR1g (W/kg)	
	Modulation, Bandwidth, RB		ncy MHz						
19.	QPSK 20MHz 1RB	Back Side	1720.0	24.67	25.0	1.079	0.464	0.501	
20.	QPSK 20MHz 50%RB	Back Side	1720.0	24.67	25.0	1.079	0.217	0.234	

LTE Band 5–Body SAR Test (Gap: 0mm)									
Plot No.	Mode	Test Position Body	Freque	Output Power (dBm)	Rated Limit (dBm)	Scaling Factor	SAR1g (W/kg)	Scaled SAR1g (W/kg)	
	Modulation, Bandwidth, RB		ncy MHz						
21.	QPSK 10MHz 1RB	Back Side	836.5	23.38	23.5	1.028	0.887	0.912	
22.	QPSK 10MHz 1RB	Back Side	829.0	22.88	23.5	1.153	0.873	1.007	
23.	QPSK 10MHz 1RB	Back Side	844.0	23.24	23.5	1.062	0.972	1.032	
24.	QPSK 10MHz 50%RB	Back Side	836.5	23.38	23.5	1.028	0.488	0.502	

LTE Band 12–Body SAR Test (Gap: 0mm)								
Plot No.	Mode	Test Position Body	Frequency	Output Power (dBm)	Rated Limit (dBm)	Scaling Factor	SAR1g (W/kg)	Scaled SAR1g (W/kg)
	Modulation, Bandwidth, RB		MHz					
25.	10MHz 1RB	Back Side	707.5	23.27	23.5	1.054	0.910	0.959
26.	10MHz 1RB	Back Side	704.0	22.92	23.5	1.143	0.897	1.025
27.	10MHz 1RB	Back Side	711.0	22.77	23.5	1.183	0.965	1.142
28.	10MHz 50%RB	Back Side	707.5	23.27	23.5	1.054	0.483	0.509

LTE Band 17–Body SAR Test (Gap: 0mm)								
Plot No.	Mode	Test Position Body	Frequency	Output Power (dBm)	Rated Limit (dBm)	Scaling Factor	SAR1g (W/kg)	Scaled SAR1g (W/kg)
	Modulation, Bandwidth, RB		MHz					
29.	QPSK 10MHz 1RB	Back Side	709.0	23.15	23.5	1.084	0.925	1.003
30.	QPSK 10MHz 1RB	Back Side	710.0	22.81	23.5	1.172	0.893	1.047
31.	QPSK 10MHz 1RB	Back Side	711.0	22.64	23.5	1.219	0.934	1.139
32.	QPSK 10MHz 50%RB	Back Side	709.0	23.15	23.5	1.084	0.492	0.533

Repeated SAR

WCDMA Band 5 – Body SAR Test (Gap: 0mm)									
Plot No.	Mode	Test Position Body	Frequency		Output Power (dBm)	Rated Limit (dBm)	Scaling Factor	SAR1g (W/kg)	Scaled SAR1g (W/kg)
			CH.	MHz					
33.	RMC 12.2k	Back Side	4183	836.6	22.86	23.0	1.033	0.913	0.943

LTE Band 5–Body SAR Test (Gap: 0mm)									
Plot No.	Mode	Test Position Body	Frequency	Output Power (dBm)	Rated Limit (dBm)	Scaling Factor	SAR1g (W/kg)	Scaled SAR1g (W/kg)	
	Modulation, Bandwidth, RB		MHz						
34.	QPSK 10MHz 1RB	Back Side	836.5	23.38	23.5	1.028	0.872	0.896	

LTE Band 12–Body SAR Test (Gap: 0mm)									
Plot No.	Mode	Test Position Body	Frequency	Output Power (dBm)	Rated Limit (dBm)	Scaling Factor	SAR1g (W/kg)	Scaled SAR1g (W/kg)	
	Modulation, Bandwidth, RB		MHz						
35.	10MHz 1RB	Back Side	707.5	23.27	23.5	1.054	0.896	0.945	

LTE Band 17–Body SAR Test (Gap: 0mm)									
Plot No.	Mode	Test Position Body	Frequency	Output Power (dBm)	Rated Limit (dBm)	Scaling Factor	SAR1g (W/kg)	Scaled SAR1g (W/kg)	
	Modulation, Bandwidth, RB		MHz						
36.	QPSK 10MHz 1RB	Back Side	709.0	23.15	23.5	1.084	0.911	0.987	

Remark:

- 1) Repeated measurement is not required when the original highest measured SAR is < 0.80 W/kg; steps 2) through 4) do not apply.
- 2) When the original highest measured SAR is \geq 0.80 W/kg, repeat that measurement once.
- 3) Perform a second repeated measurement only if the ratio of largest to smallest SAR for the original and first repeated measurements is > 1.20 or when the original or repeated measurement is \geq 1.45 W/kg (~ 10% from the 1-g SAR limit).
- 4) Perform a third repeated measurement only if the original, first or second repeated measurement is \geq 1.5 W/kg and the ratio of largest to smallest SAR for the original, first and second repeated measurements is > 1.20

10. Measurement Uncertainty

10.1 Uncertainty for EUT SAR Test

a	b	c	d	e= f(d,k)	f	g	h= c*f/e	i= c*g/e	k
Uncertainty Component	Sec.	Tol (+- %)	Prob. Dist.	Div.	Ci (1g)	Ci (10g)	1g Ui (+-%)	10g Ui (+-%)	Vi
Measurement System									
Probe calibration	E.2.1	7.0	N	1	1	1	7.00	7.00	∞
Axial Isotropy	E.2.2	2.5	R	$\sqrt{3}$	$(1_{-}Cp)^{1/2}$	$(1_{-}Cp)^{1/2}$	1.02	1.02	∞
Hemispherical Isotropy	E.2.2	4.0	R	$\sqrt{3}$	$(Cp)^{1/2}$	$(Cp)^{1/2}$	1.63	1.63	∞
Boundary effect	E.2.3	1.0	R	$\sqrt{3}$	1	1	0.58	0.58	∞
Linearity	E.2.4	5.0	R	$\sqrt{3}$	1	1	2.89	2.89	∞
System detection limits	E.2.5	1.0	R	$\sqrt{3}$	1	1	0.58	0.58	∞
Readout Electronics	E.2.6	0.02	N	1	1	1	0.02	0.02	∞
Reponse Time	E.2.7	3.0	R	$\sqrt{3}$	1	1	1.73	1.73	∞
Integration Time	E.2.8	2.0	R	$\sqrt{3}$	1	1	1.15	1.15	∞
RF ambient Conditions – Noise	E.6.1	3.0	R	$\sqrt{3}$	1	1	1.73	1.73	∞
RF ambient Conditions - Reflections	E.6.1	3.0	R	$\sqrt{3}$	1	1	1.73	1.73	∞
Probe positioner Mechanical Tolerance	E.6.2	2.0	R	$\sqrt{3}$	1	1	1.15	1.15	∞
Probe positioning with respect to Phantom Shell	E.6.3	0.05	R	$\sqrt{3}$	1	1	0.03	0.03	∞
Extrapolation, interpolation and integration Algorithms for Max. SAR Evaluation	E.5	5.0	R	$\sqrt{3}$	1	1	2.89	2.89	∞
Test Sample Related									
Test sample positioning	E.4.2	0.03	N	1	1	1	0.03	0.03	N-1
Device Holder Uncertainty	E.4.1	5.00	N	1	1	1	5.00	5.00	
Output power Variation - SAR drift measurement	E.2.9	12.02	R	$\sqrt{3}$	1	1	6.94	6.94	∞
SAR scaling	E6.5	0.0	R	$\sqrt{3}$	1	1	0.0	0.0	∞
Phantom and Tissue Parameters									
Phantom Uncertainty (Shape and thickness tolerances)	E.3.1	0.05	R	$\sqrt{3}$	1	1	0.03	0.03	∞
Uncertainty in SAR correction for deviations in permittivity and conductivity	E3.2	1.9	R	$\sqrt{3}$	1	0.84	1.10	0.90	∞

Liquid conductivity - deviation from target value	E.3.2	5.00	R	$\sqrt{3}$	0.64	0.43	1.85	1.24	∞
Liquid conductivity - measurement uncertainty	E.3.3	5.00	N	1	0.64	0.43	3.20	2.15	∞
Liquid permittivity - deviation from target value	E.3.2	0.37	R	$\sqrt{3}$	0.6	0.49	0.13	0.10	∞
Liquid permittivity - measurement uncertainty	E.3.3	10.00	N	1	0.6	0.49	6.00	4.90	∞
Combined Standard Uncertainty			RSS				12.98	12.53	
Expanded Uncertainty (95% Confidence interval)			K=2				25.32	24.43	

10.2 Uncertainty for System Performance Check

a	b	c	d	e= f(d,k)	f	g	h= c*f/e	i= c*g/e	k
Uncertainty Component	Sec.	Tol (+-%)	Prob. Dist.	Div.	Ci (1g)	Ci (10g)	1g Ui (+-%)	10g Ui (+-%)	Vi
Measurement System									
Probe calibration	E.2.1	7.0	N	1	1	1	7.00	7.00	∞
Axial Isotropy	E.2.2	2.5	R	$\sqrt{3}$	$(1_{-Cp})^{1/2}$	$(1_{-Cp})^{1/2}$	1.02	1.02	∞
Hemispherical Isotropy	E.2.2	4.0	R	$\sqrt{3}$	$(Cp)^{1/2}$	$(Cp)^{1/2}$	1.63	1.63	∞
Boundary effect	E.2.3	1.0	R	$\sqrt{3}$	1	1	0.58	0.58	∞
Linearity	E.2.4	5.0	R	$\sqrt{3}$	1	1	2.89	2.89	∞
System detection limits	E.2.5	1.0	R	$\sqrt{3}$	1	1	0.58	0.58	∞
Modulation response	E.2.5	0	R	$\sqrt{3}$	0	0	0.0	0.0	∞
Readout Electronics	E.2.6	0.02	N	1	1	1	0.02	0.02	∞
Reponse Time	E.2.7	3.0	R	$\sqrt{3}$	1	1	1.73	1.73	∞
Integration Time	E.2.8	2.0	R	$\sqrt{3}$	1	1	1.15	1.15	∞
RF ambient Conditions – Noise	E.6.1	3.0	R	$\sqrt{3}$	1	1	1.73	1.73	∞
RF ambient Conditions - Reflections	E.6.1	3.0	R	$\sqrt{3}$	1	1	1.73	1.73	∞
Probe positioner Mechanical Tolerance	E.6.2	2.0	R	$\sqrt{3}$	1	1	1.15	1.15	∞
Probe positioning with respect to Phantom Shell	E.6.3	0.05	R	$\sqrt{3}$	1	1	0.03	0.03	∞
Extrapolation, interpolation and	E.5.2	5.0	R	$\sqrt{3}$	1	1	2.89	2.89	∞

integration Algorithms for Max. SAR Evaluation									
Dipole									
Dipole axis to liquid Distance	8,E.4.2	1.00	N	$\sqrt{3}$	1	1	0.58	0.58	N-1
Input power and SAR drift measurement	8,6.6.2	12.02	R	$\sqrt{3}$	1	1	6.94	6.94	∞
Deviation of experimental dipole from numerical dipole	E.6.4	5.5	R	$\sqrt{3}$	1	1	3.20	3.20	∞
Phantom and Tissue Parameters									
Phantom Uncertainty (Shape and thickness tolerances)	E.3.1	0.05	R	$\sqrt{3}$	1	1	0.03	0.03	∞
Uncertainty in SAR correction for deviations in permittivity and conductivity	E3.2	2.0	R	$\sqrt{3}$	1	0.84	1.10	1.10	∞
Liquid conductivity - deviation from target value	E.3.2	5.00	R	$\sqrt{3}$	0.64	0.43	1.85	1.24	
Liquid conductivity - measurement uncertainty	E.3.3	5.00	N	1	0.64	0.43	3.20	2.15	
Liquid permittivity - deviation from target value	E.3.2	0.37	R	$\sqrt{3}$	0.6	0.49	0.13	0.10	
Liquid permittivity - measurement uncertainty	E.3.3	10.00	N	1	0.6	0.49	6.00	4.90	M
Combined Standard Uncertainty			RSS				12.00	11.50	
Expanded Uncertainty (95% Confidence interval)			K=2				23.39	22.43	

Annex A. Plots of System Performance Check

MEASUREMENT 1

For Head Liquid

Type: Validation measurement (Fast, 75.00 %)

Date of measurement: 08/12/2019

Measurement duration: 7 minutes 21 seconds

E-field Probe: SSE5 - SN 09/13 EP168; ConvF: 6.99; Calibrated: 05/22/2019

A. Experimental conditions

Area Scan	dx=8mm dy=8mm
Zoom Scan	dx=8mm dy=8mm dz=5mm
Phantom	Validation plane
Device Position	Dipole
Band	CW750
Signal	Duty Cycle 1:1

B. SAR Measurement Results

Frequency (MHz)	750.000000
Relative Permittivity (real part)	41.320574
Conductivity (S/m)	0.862373
Power Variation (%)	0.038363
Ambient Temperature	21.1
Liquid Temperature	21.3

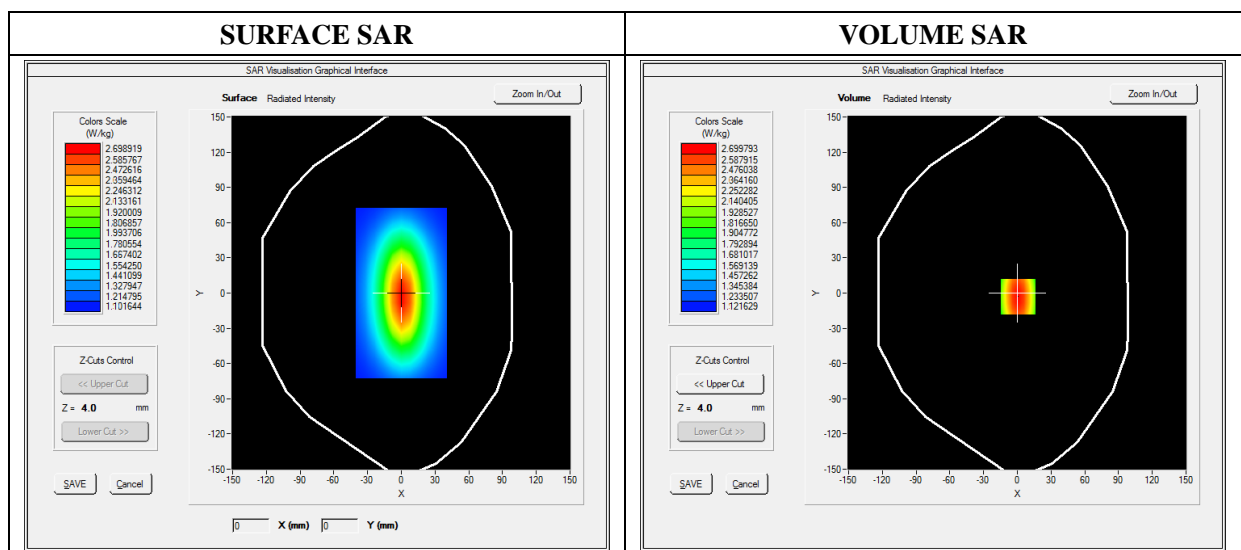

Maximum location: X=0.00, Y=0.00

SAR 10g (W/Kg)	1.042744
SAR 1g (W/Kg)	2.164534

Z Axis Scan

Z (mm)	0.00	4.00	9.00	14.00	19.00	24.00	29.00
SAR (W/Kg)	0.0000	2.3634	1.8023	1.4523	1.2514	1.1005	1.0245

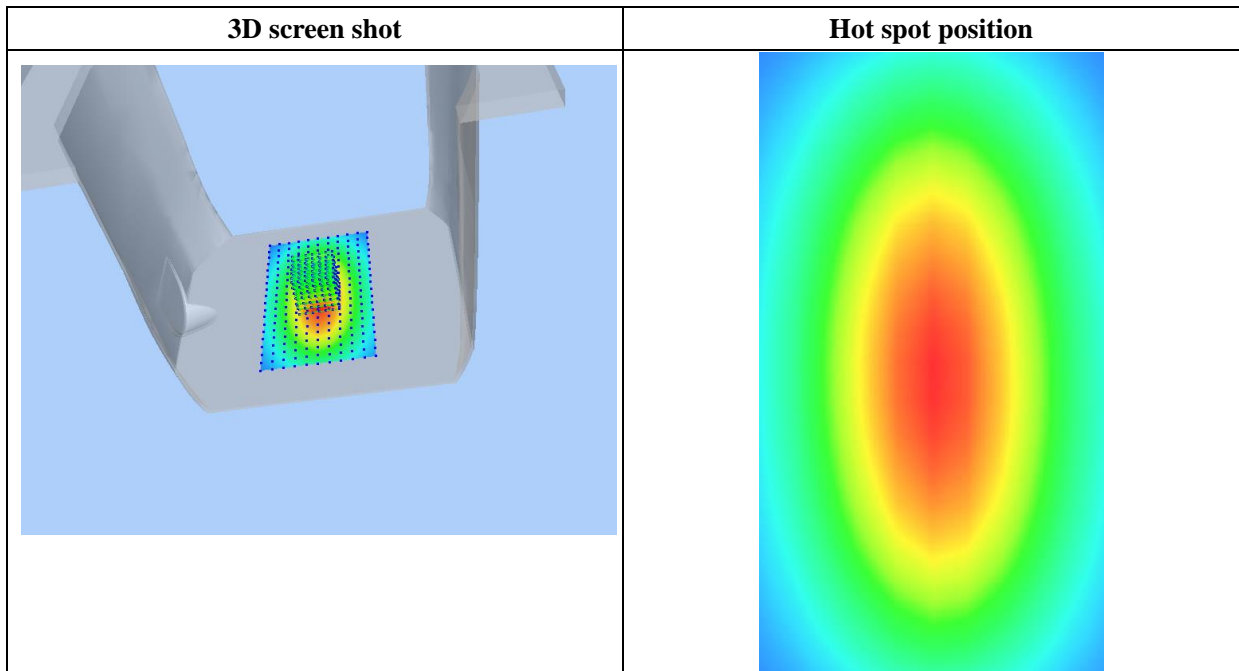
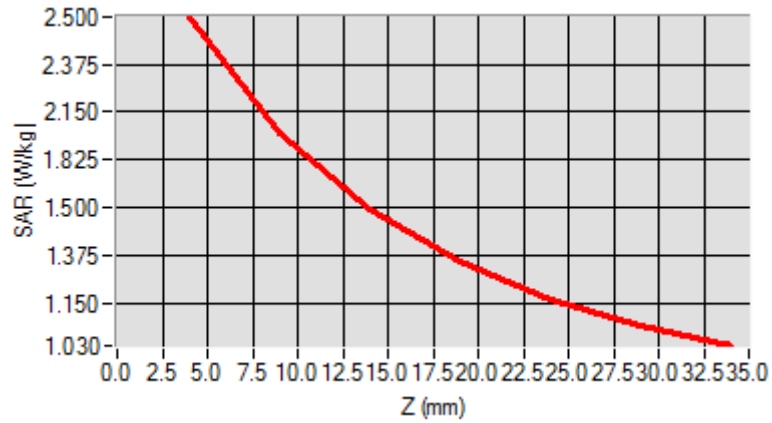

MEASUREMENT 2

For Head Liquid

Type: Validation measurement (Fast, 75.00 %)

Date of measurement: 08/12/2019

Measurement duration: 7 minutes 21 seconds

E-field Probe: SSE5 - SN 09/13 EP168; ConvF: 6.93; Calibrated: 05/22/2019

A. Experimental conditions

Area Scan	dx=8mm dy=8mm
Zoom Scan	dx=8mm dy=8mm dz=5mm
Phantom	Validation plane
Device Position	Dipole
Band	CW835
Signal	Duty Cycle 1:1

B. SAR Measurement Results

Frequency (MHz)	835.000000
Relative Permittivity (real part)	41.110245
Conductivity (S/m)	0.871245
Power Variation (%)	0.038437
Ambient Temperature	21.1
Liquid Temperature	21.3

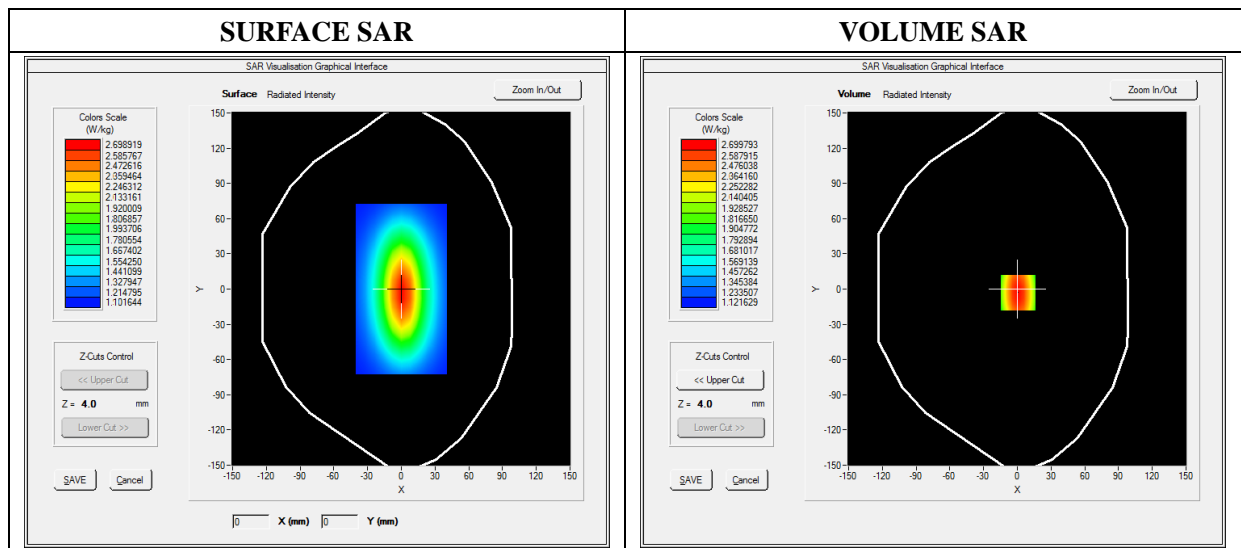

Maximum location: X=0.00, Y=0.00

SAR 10g (W/Kg)	1.129489
SAR 1g (W/Kg)	2.411253

Z Axis Scan

Z (mm)	0.00	4.00	9.00	14.00	19.00	24.00	29.00
SAR (W/Kg)	0.0000	2.4900	1.8942	1.4811	1.3541	1.1123	1.0539

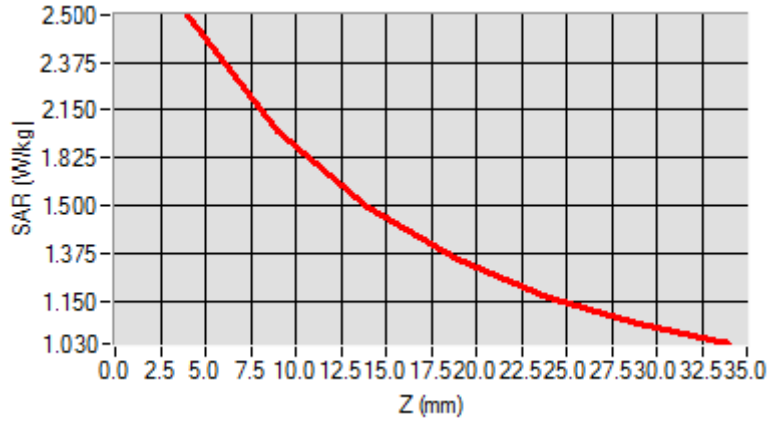

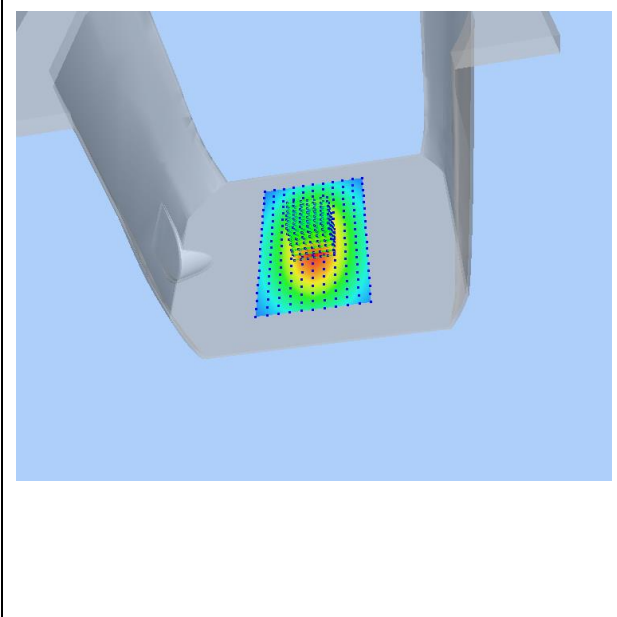
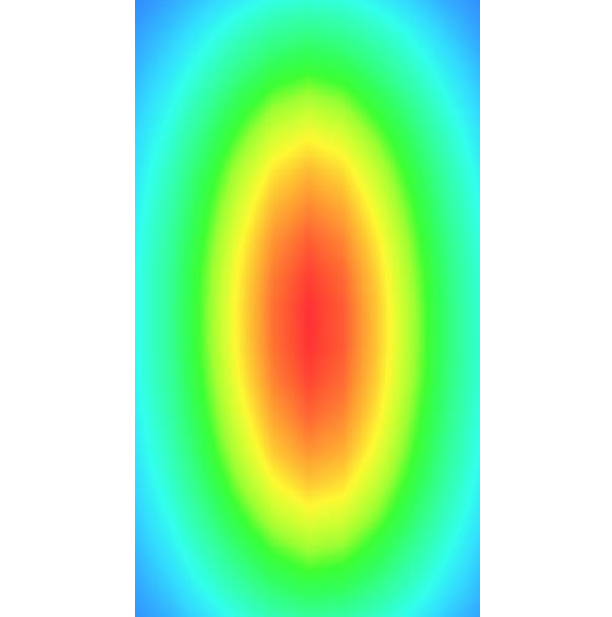
3D screen shot	Hot spot position
	

MEASUREMENT 3

For Head Liquid

Type: Validation measurement (Fast, 75.00 %)

Date of measurement: 08/13/2019

Measurement duration: 12 minutes 21 seconds

E-field Probe: SSE5 - SN 09/13 EP168; ConvF: 5.84; Calibrated: 05/22/2019

A. Experimental conditions

Area Scan	dx=8mm dy=8mm
Zoom Scan	dx=8mm dy=8mm dz=5mm
Phantom	Validation plane
Device Position	Dipole
Band	CW1800
Signal	CW (Crest factor: 1.0)

B. SAR Measurement Results

Frequency (MHz)	1800.000000
Relative Permittivity (real part)	39.024890
Conductivity (S/m)	1.371250
Power Variation (%)	1.401232
Ambient Temperature	21.1
Liquid Temperature	21.2

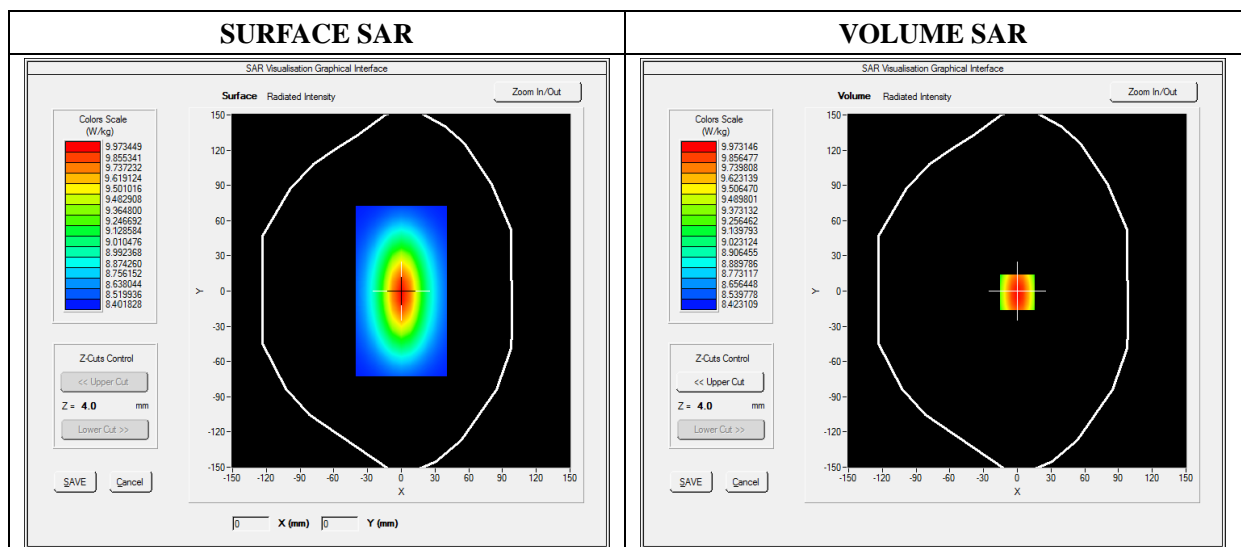

Maximum location: X=0.00, Y=0.00

SAR 10g (W/Kg)	5.171252
SAR 1g (W/Kg)	9.611250

Z Axis Scan

Z (mm)	0.00	4.00	9.00	14.00	19.00	24.00	29.00
SAR (W/Kg)	0.0000	10.3455	7.1125	5.1026	3.425	3.0242	2.1125

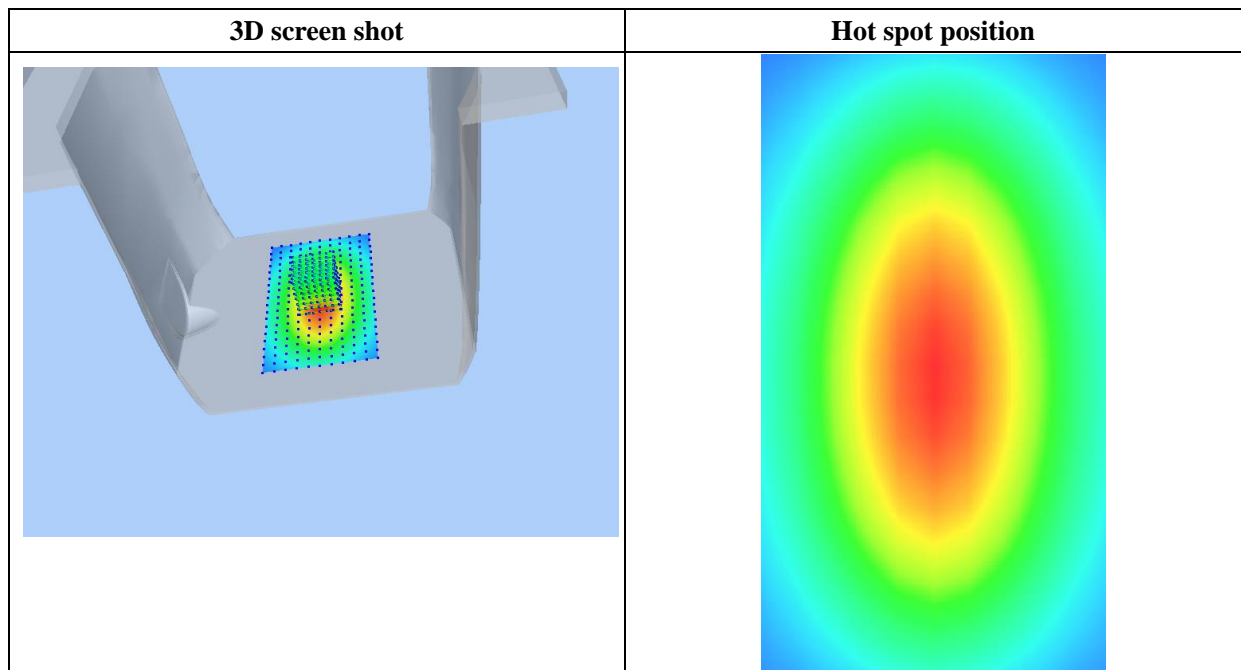
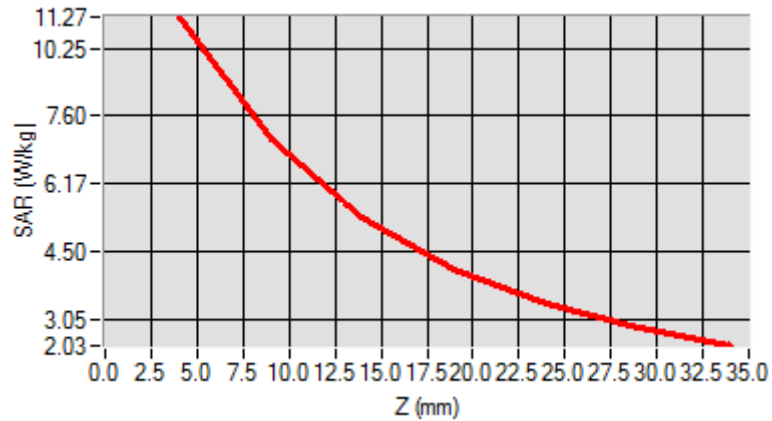

MEASUREMENT 4

For Head Liquid

Type: Validation measurement (Fast, 75.00 %)

Date of measurement: 08/13/2019

Measurement duration: 12 minutes 21 seconds

E-field Probe: SSE5 - SN 09/13 EP168; ConvF: 6.35; Calibrated: 05/22/2019

A. Experimental conditions

Area Scan	dx=8mm dy=8mm
Zoom Scan	dx=8mm dy=8mm dz=5mm
Phantom	Validation plane
Device Position	Dipole
Band	CW1900
Signal	Duty Cycle 1:1

B. SAR Measurement Results

Frequency (MHz)	1900.000000
Relative Permittivity (real part)	38.560124
Conductivity (S/m)	1.380369
Power Variation (%)	1.022540
Ambient Temperature	21.1
Liquid Temperature	21.3

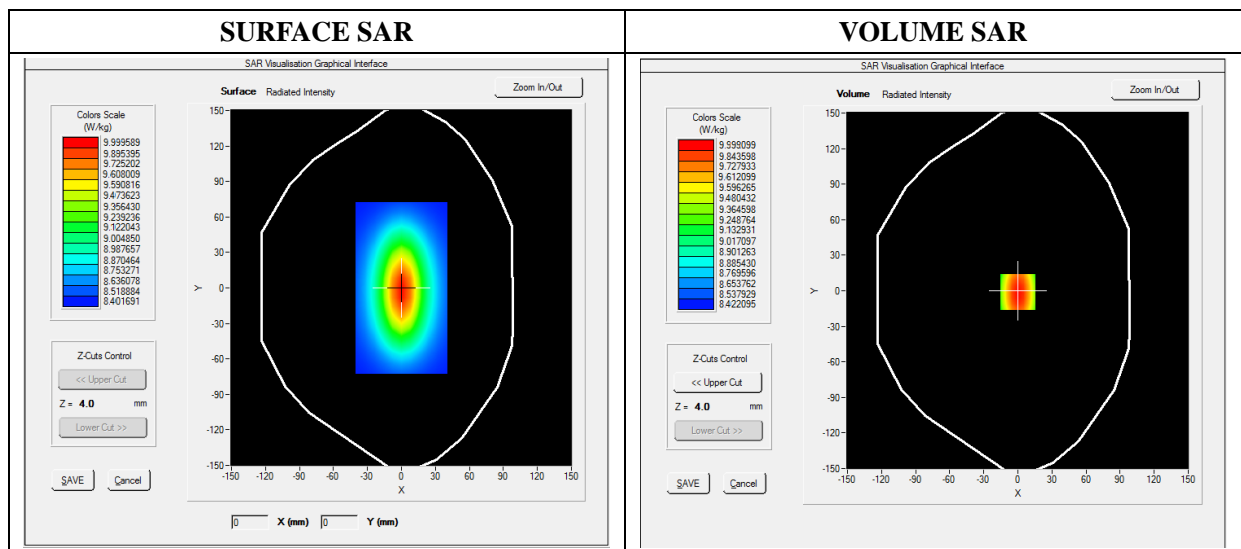

Maximum location: X=0.00, Y=0.00

SAR 10g (W/Kg)	7.174526
SAR 1g (W/Kg)	9.913214

Z Axis Scan

Z (mm)	0.00	4.00	9.00	14.00	19.00	24.00	29.00
SAR (W/Kg)	0.0000	10.2354	6.8400	5.0121	4.1189	3.0522	2.8424

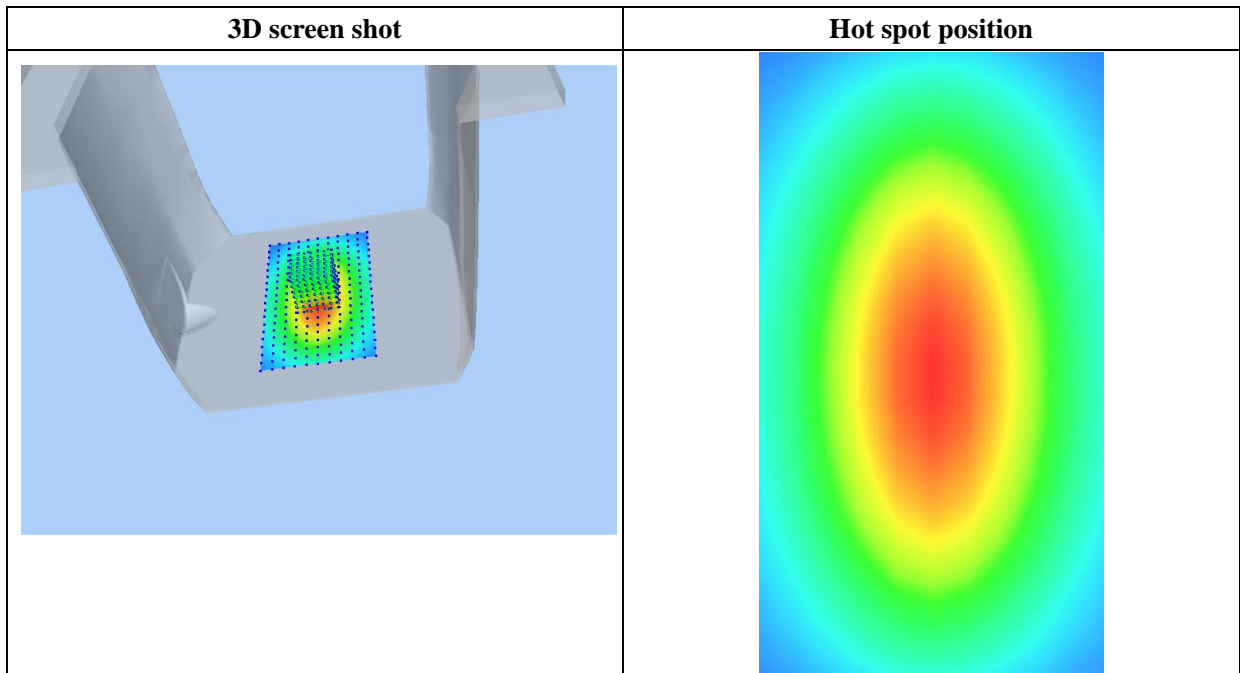
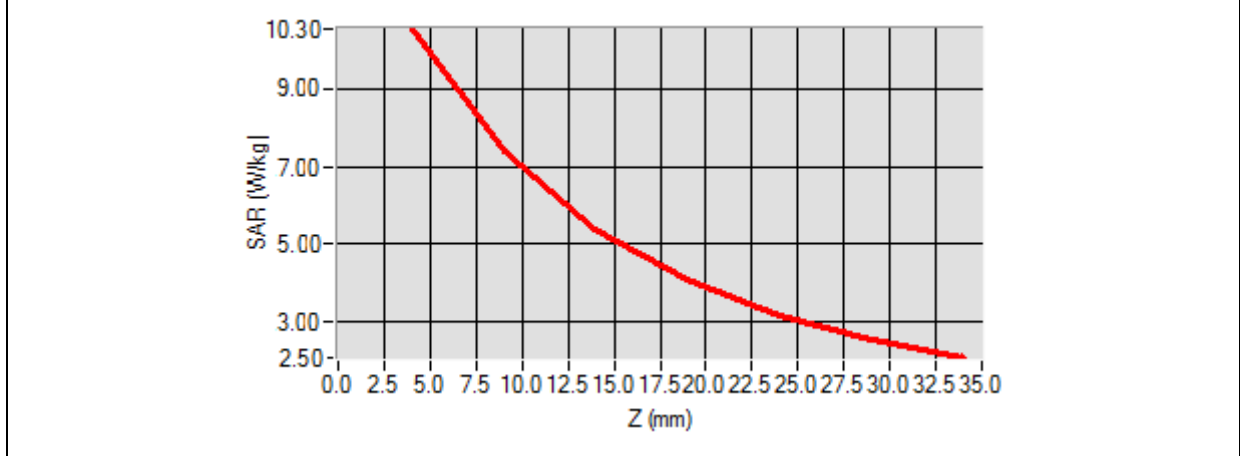

MEASUREMENT 5

For Body Liquid

Type: Validation measurement (Fast, 75.00 %)

Date of measurement: 08/12/2019

Measurement duration: 12 minutes 21 seconds

E-field Probe: SSE5 - SN 09/13 EP168; ConvF: 7.28; Calibrated: 05/22/2019

A. Experimental conditions

Area Scan	dx=8mm dy=8mm
Zoom Scan	dx=8mm dy=8mm dz=5mm
Phantom	Validation plane
Device Position	Dipole
Band	CW750
Signal	Duty Cycle 1:1

B. SAR Measurement Results

Frequency (MHz)	750.000000
Relative Permittivity (real part)	54.964739
Conductivity (S/m)	0.931048
Power Variation (%)	0.034745
Ambient Temperature	21.1
Liquid Temperature	21.3

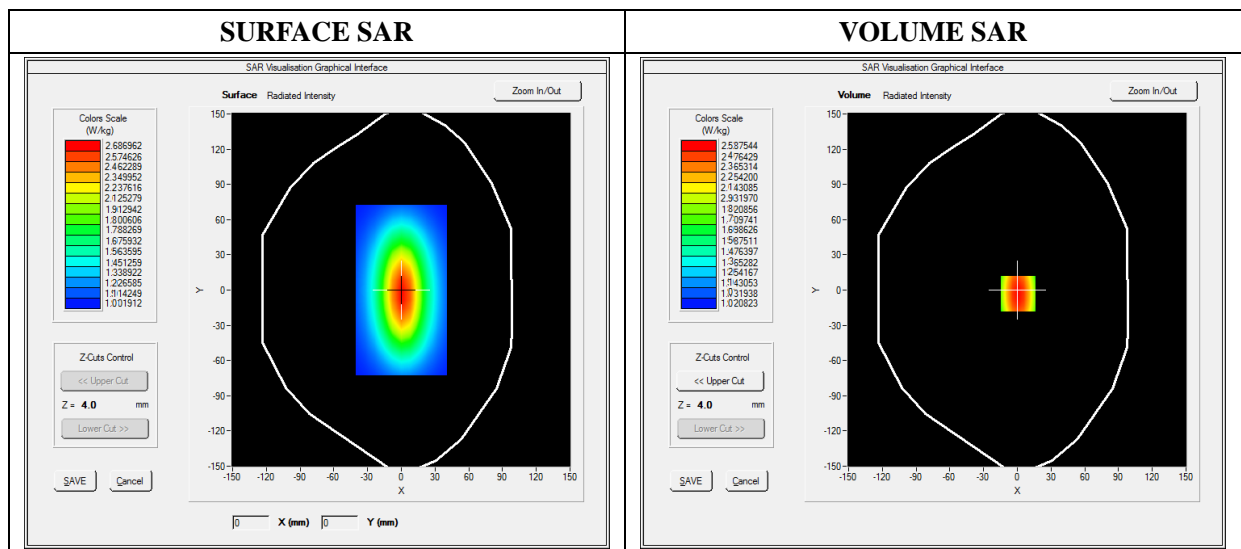

Maximum location: X=0.00, Y=0.00

SAR 10g (W/Kg)	1.000865
SAR 1g (W/Kg)	2.124211

Z Axis Scan

Z (mm)	0.00	4.00	9.00	14.00	19.00	24.00	29.00
SAR (W/Kg)	0.0000	2.5132	1.1087	0.8214	0.5160	0.4875	0.4864

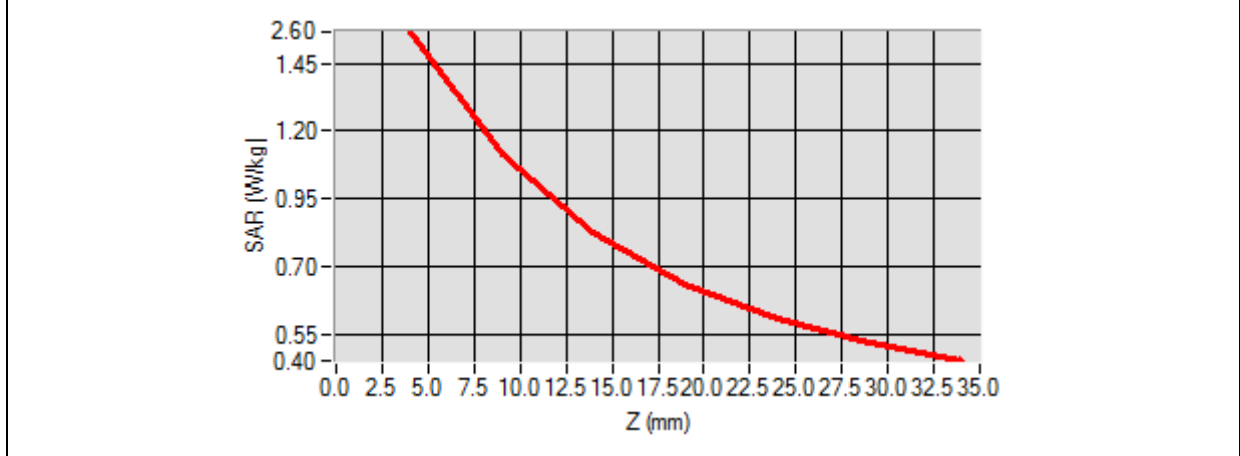

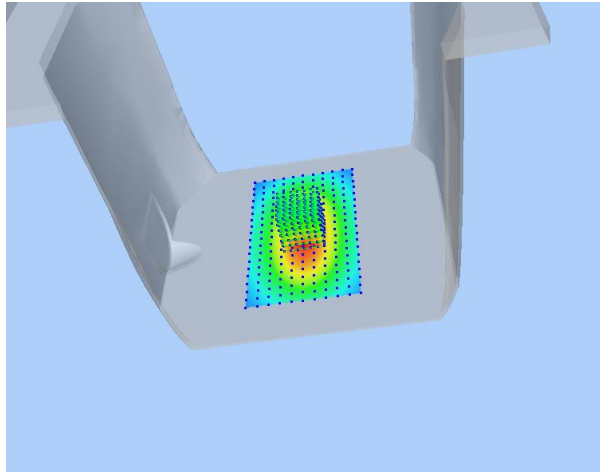
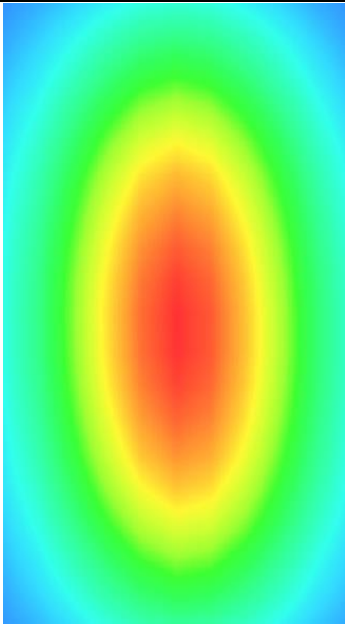
3D screen shot	Hot spot position
	

MEASUREMENT 6

For Body Liquid

Type: Validation measurement (Fast, 75.00 %)

Date of measurement: 08/12/2019

Measurement duration: 12 minutes 21 seconds

E-field Probe: SSE5 - SN 09/13 EP168; ConvF: 7.13; Calibrated: 05/22/2019

A. Experimental conditions

Area Scan	dx=8mm dy=8mm
Zoom Scan	dx=8mm dy=8mm dz=5mm
Phantom	Validation plane
Device Position	Dipole
Band	CW835
Signal	Duty Cycle 1:1

B. SAR Measurement Results

Frequency (MHz)	835.000000
Relative Permittivity (real part)	54.851214
Conductivity (S/m)	0.951454
Power Variation (%)	0.901472
Ambient Temperature	21.1
Liquid Temperature	21.3

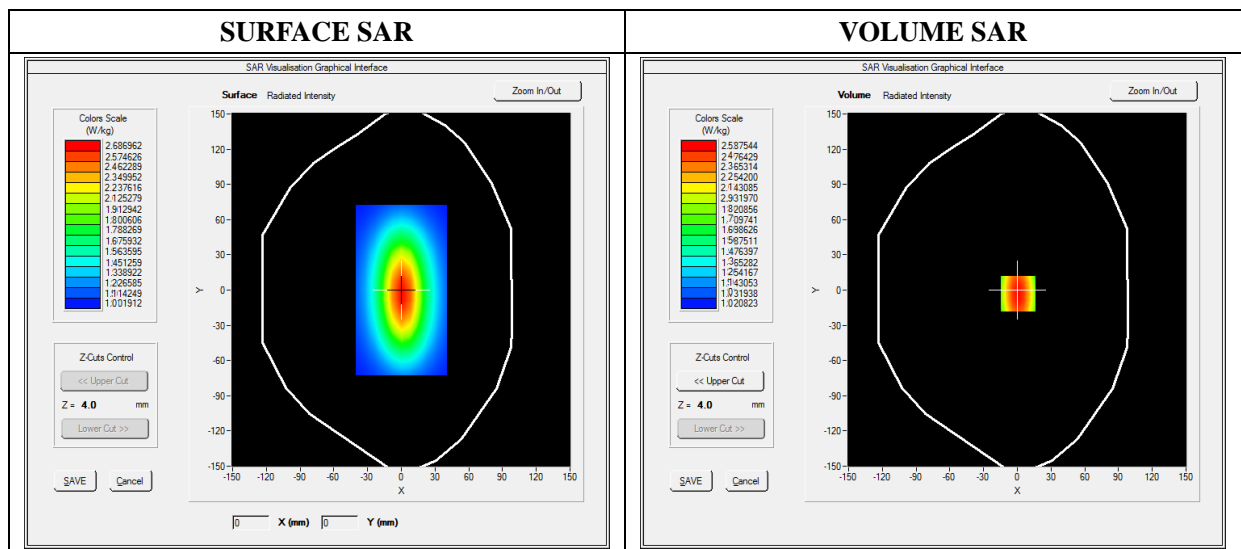

Maximum location: X=0.00, Y=0.00

SAR 10g (W/Kg)	1.028956
SAR 1g (W/Kg)	2.354211

Z Axis Scan

Z (mm)	0.00	4.00	9.00	14.00	19.00	24.00	29.00
SAR (W/Kg)	0.0000	2.5789	1.1300	0.8795	0.5940	0.5011	0.5100

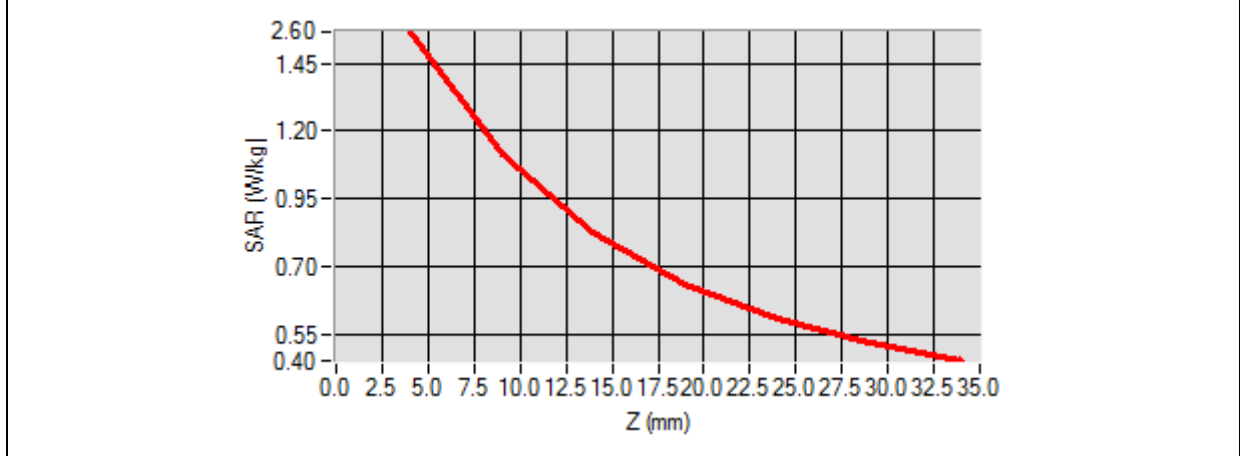

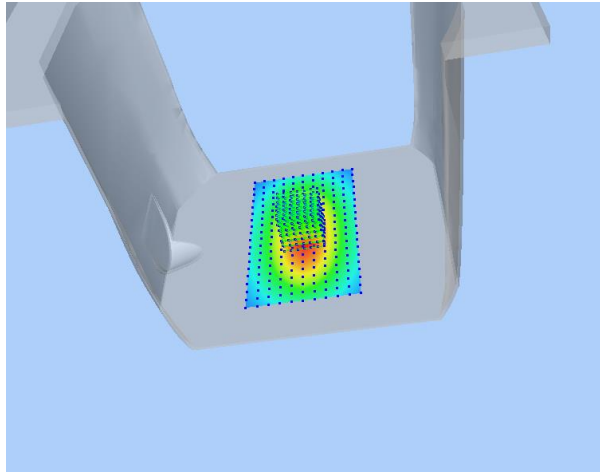
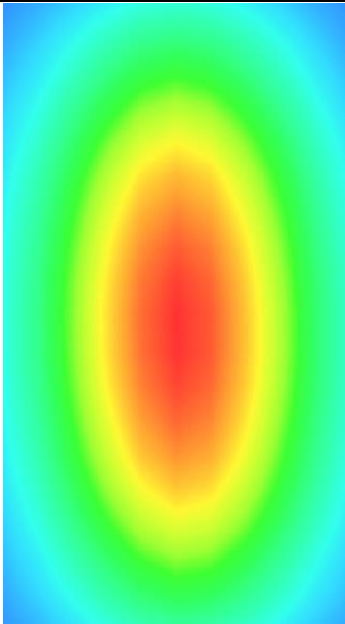
3D screen shot	Hot spot position
	

MEASUREMENT 7

For Body Liquid

Type: Validation measurement (Fast, 75.00 %)

Date of measurement: 08/13/2019

Measurement duration: 12 minutes 21 seconds

E-field Probe: SSE5 - SN 09/13 EP168; ConvF: 6.06; Calibrated: 05/22/2019

A. Experimental conditions

Area Scan	dx=8mm dy=8mm
Zoom Scan	dx=8mm dy=8mm dz=5mm
Phantom	Validation plane
Device Position	Dipole
Band	CW1800
Signal	CW (Crest factor: 1.0)

B. SAR Measurement Results

Frequency (MHz)	1800.000000
Relative Permittivity (real part)	51.224510
Conductivity (S/m)	1.461261
Power Variation (%)	0.845690
Ambient Temperature	21.1
Liquid Temperature	21.2

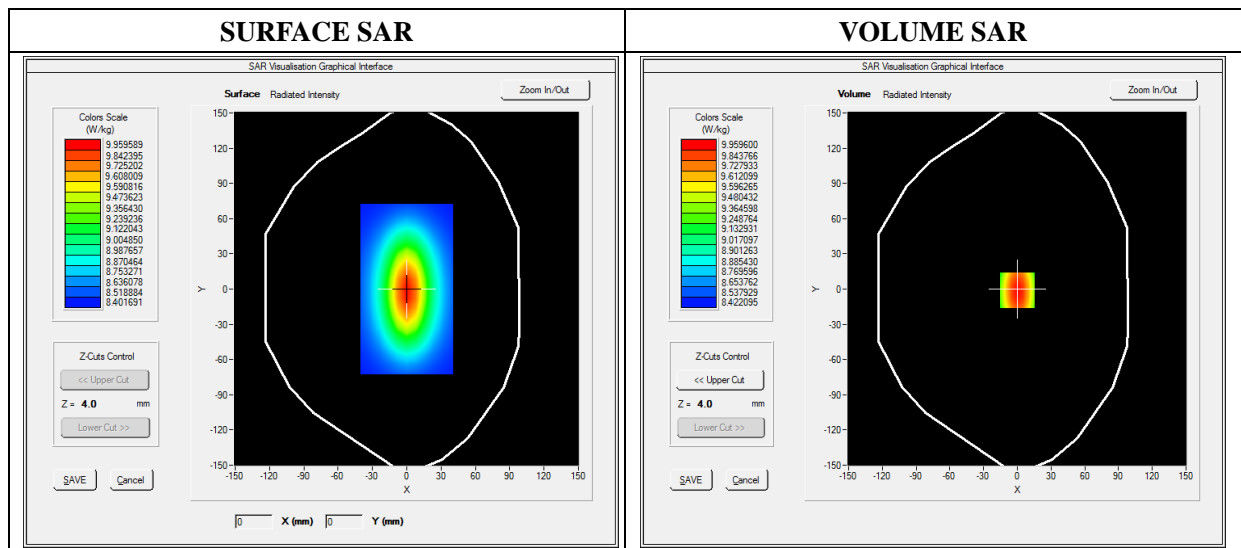

Maximum location: X=0.00, Y=0.00

SAR 10g (W/Kg)	5.221202
SAR 1g (W/Kg)	9.582560

Z Axis Scan

Z (mm)	0.00	4.00	9.00	14.00	19.00	24.00	29.00
SAR (W/Kg)	0.0000	11.2425	9.4123	8.0345	6.9125	6.3092	3.9460

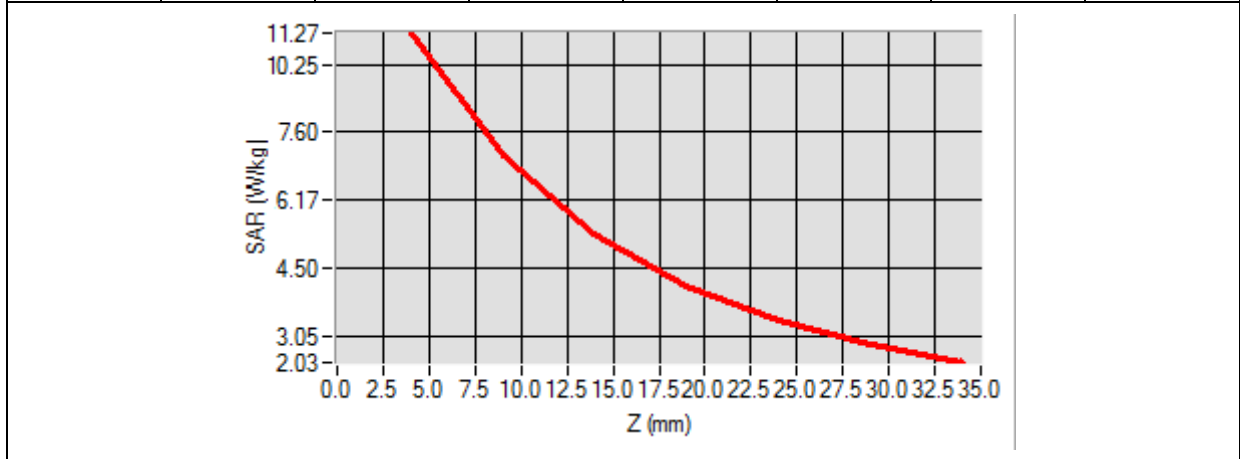

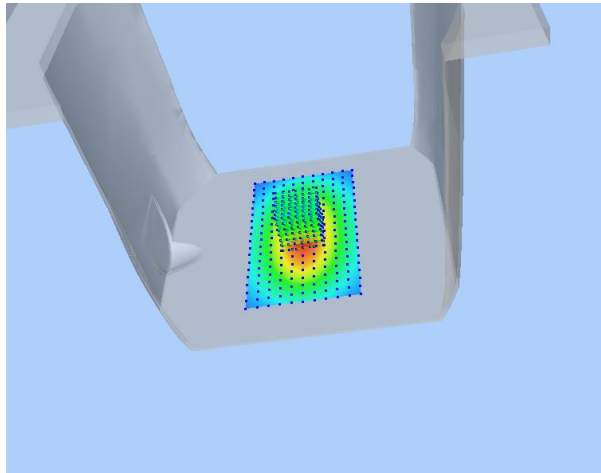
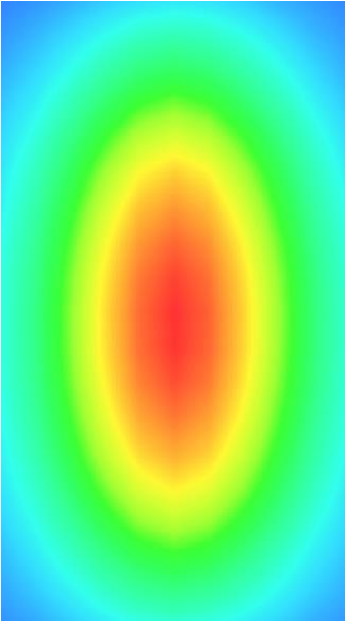
3D screen shot	Hot spot position
	

MEASUREMENT 8

For Body Liquid

Type: Validation measurement (Fast, 75.00 %)

Date of measurement: 08/13/2019

Measurement duration: 12 minutes 21 seconds

E-field Probe: SSE5 - SN 09/13 EP168; ConvF: 6.55; Calibrated: 05/22/2019

A. Experimental conditions

Area Scan	dx=8mm dy=8mm
Zoom Scan	dx=8mm dy=8mm dz=5mm
Phantom	Validation plane
Device Position	Dipole
Band	CW1900
Signal	Duty Cycle 1:1

B. SAR Measurement Results

Frequency (MHz)	1900.000000
Relative Permittivity (real part)	52.420415
Conductivity (S/m)	1.501966
Power Variation (%)	0.541872
Ambient Temperature	21.1
Liquid Temperature	21.3

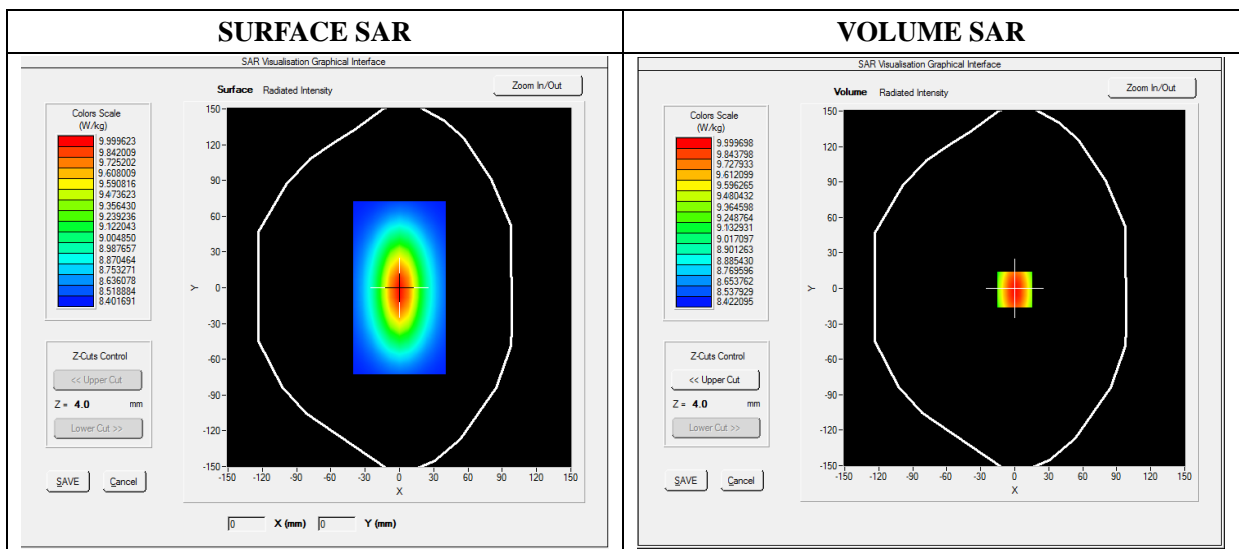

Maximum location: X=0.00, Y=0.00

SAR 10g (W/Kg)	5.134651
SAR 1g (W/Kg)	9.781550

Z Axis Scan

Z (mm)	0.00	4.00	9.00	14.00	19.00	24.00	29.00
SAR (W/Kg)	0.0000	10.2031	6.43001	4.9011	4.5325	3.1201	2.5024

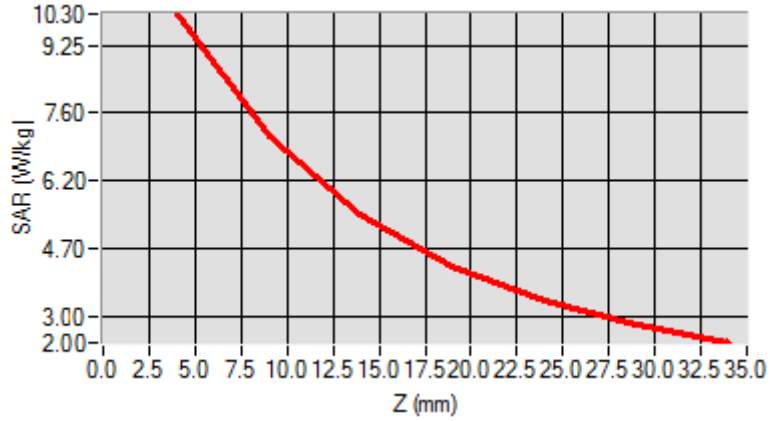

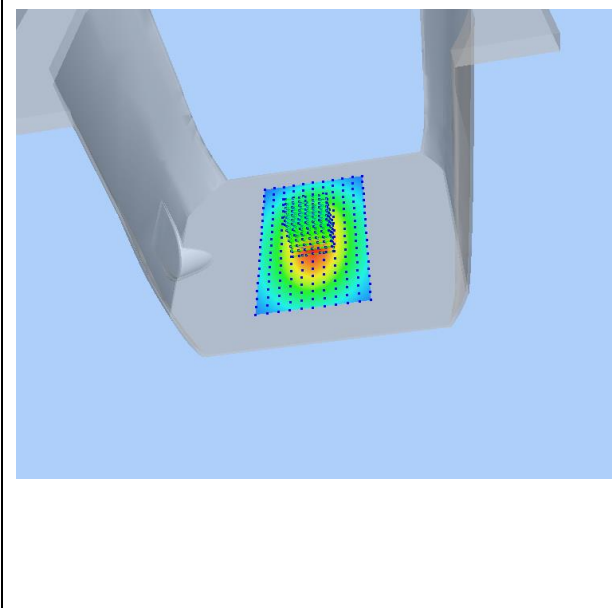
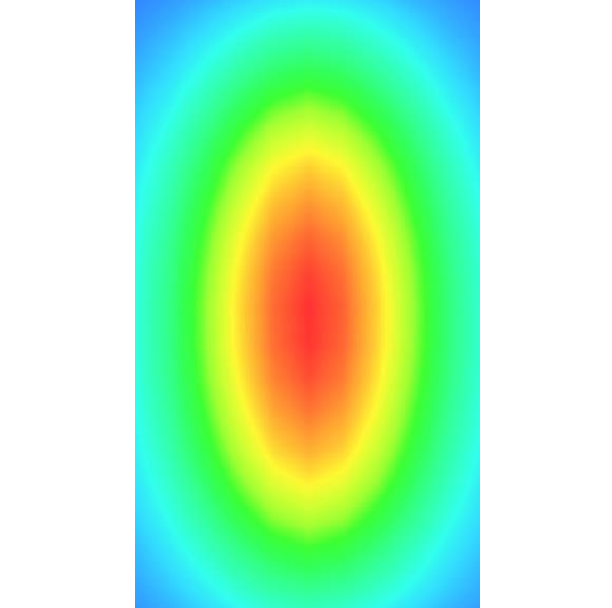
3D screen shot	Hot spot position
	

Annex B. Plots of SAR Measurement

<u>BAND</u>	<u>PARAMETERS</u>
WCDMA1900	<u>Measurement 1</u> : Flat Plane with Front side(Front-of-face) device position on High Channel in WCDMA mode
WCDMA850	<u>Measurement 2</u> : Flat Plane with Front side(Front-of-face) device position on Middle Channel in WCDMA mode
LTE Band 2	<u>Measurement 3</u> : Flat Plane with Front side(Front-of-face) device position on Low Channel in LTE mode
LTE Band 4	<u>Measurement 5</u> : Flat Plane with Front side(Front-of-face) device position on Low Channel in LTE mode
LTE Band 5	<u>Measurement 7</u> : Flat Plane with Front side(Front-of-face) device position on Middle Channel in LTE mode
LTE Band 12	<u>Measurement 9</u> : Flat Plane with Front side(Front-of-face) device position on Middle Channel in LTE mode
LTE Band 17	<u>Measurement 11</u> : Flat Plane with Front side(Front-of-face) device position on Low Channel in LTE mode
WCDMA1900	<u>Measurement 13</u> : Flat Plane with Back side device position on High Channel in WCDMA mode
WCDMA850	<u>Measurement 15</u> : Flat Plane with Back device position on Low Channel in WCDMA mode
LTE Band 2	<u>Measurement 17</u> : Flat Plane with Back device position on Low Channel in LTE mode
LTE Band 4	<u>Measurement 19</u> : Flat Plane with Back device position on Low Channel in LTE mode
LTE Band 5	<u>Measurement 23</u> : Flat Plane with Back device position on High Channel in LTE mode
LTE Band 12	<u>Measurement 27</u> : Flat Plane with Back device position on High Channel in LTE mode
LTE Band 17	<u>Measurement 31</u> : Flat Plane with Back device position on High Channel in LTE mode
<i>Remark: SAR plot is showed the highest measured SAR in each exposure configuration, wireless mode and frequency band combination.</i>	

MEASUREMENT 1

Type: Phone measurement (Complete)

Date of measurement: 08/13/2019

Measurement duration: 12 minutes 3 seconds

E-field Probe: SSE5 - SN 09/13 EP168; ConvF: 6.35; Calibrated: 05/22/2019

A. Experimental conditions

Area Scan	dx=8mm dy=8mm
Zoom Scan	dx=8mm dy=8mm dz=5mm
Phantom	Flat plane
Device Position	Front
Band	WCDMA1900_RMC
Channels	High
Signal	Duty Cycle 1:1

B. SAR Measurement Results

Frequency (MHz)	1907.600000
Relative Permittivity (real part)	38.560124
Conductivity (S/m)	1.380369
Power Variation (%)	1.524540
Ambient Temperature	21.1
Liquid Temperature	21.3

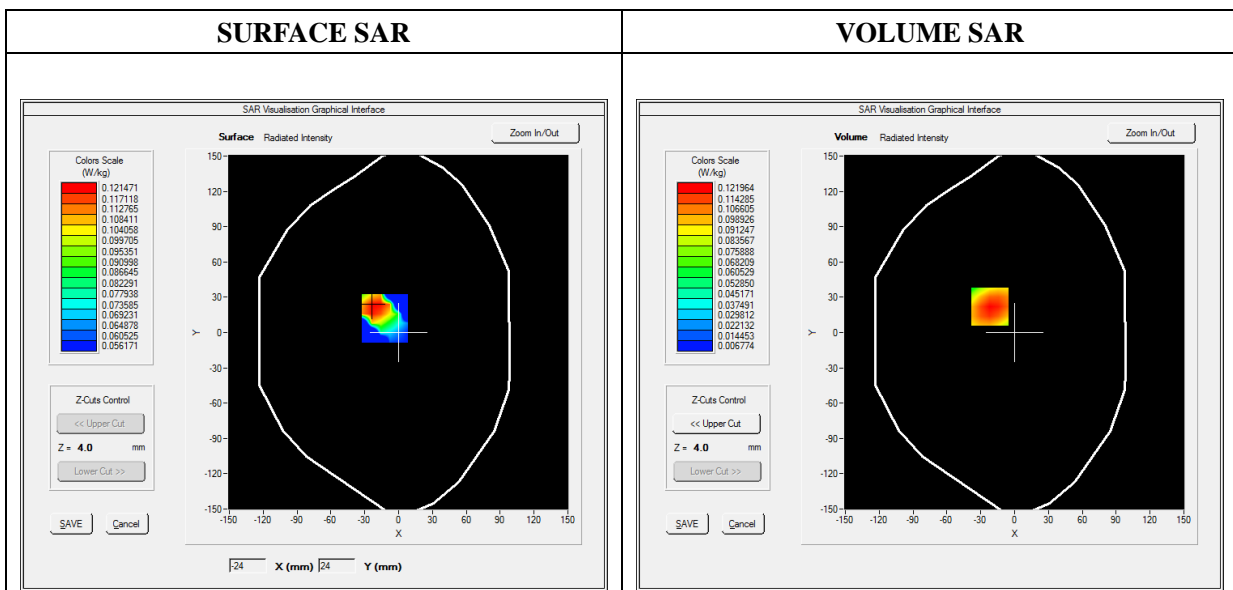

Maximum location: X=-22.00, Y=22.00

SAR Peak: 0.19 W/kg

SAR 10g (W/Kg)	0.067384
SAR 1g (W/Kg)	0.116479

Z (mm)	0.00	4.00	9.00	14.00	19.00
SAR (W/Kg)	0.1900	0.1220	0.0682	0.0381	0.0221

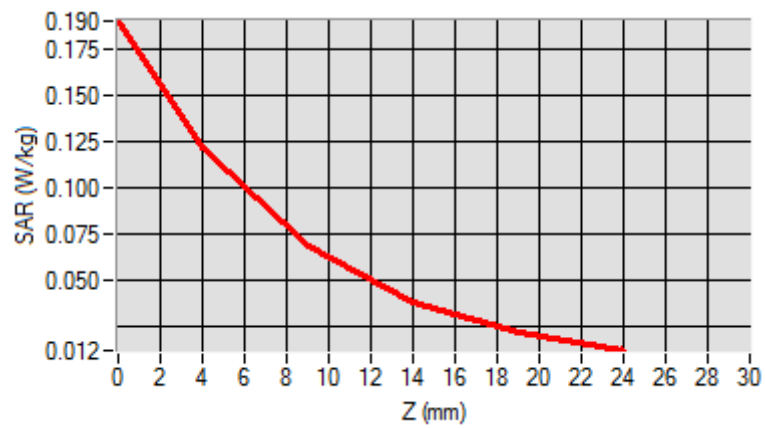

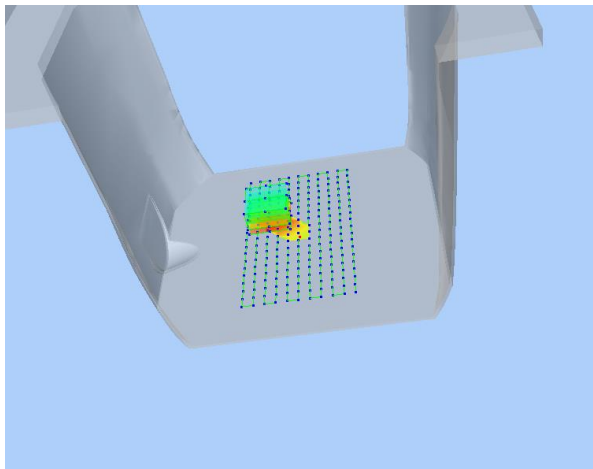
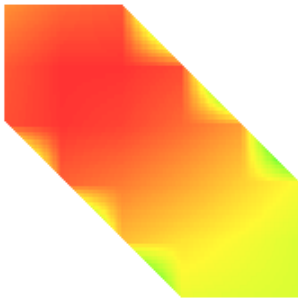
3D screen shot	Hot spot position
	

MEASUREMENT 2

Type: Phone measurement (Complete)

Date of measurement: 08/12/2019

Measurement duration: 12 minutes 3 seconds

E-field Probe: SSE5 - SN 09/13 EP168; ConvF: 6.93; Calibrated: 05/22/2019

A. Experimental conditions

Area Scan	dx=8mm dy=8mm
Zoom Scan	dx=8mm dy=8mm dz=5mm
Phantom	Flat plane
Device Position	Front
Band	WCDMA850_RMC
Channels	Middle
Signal	Duty Cycle 1:1

B. SAR Measurement Results

Frequency (MHz)	836.600000
Relative Permittivity (real part)	41.110245
Conductivity (S/m)	0.871245
Power Variation (%)	1.342427
Ambient Temperature	21.1
Liquid Temperature	21.3

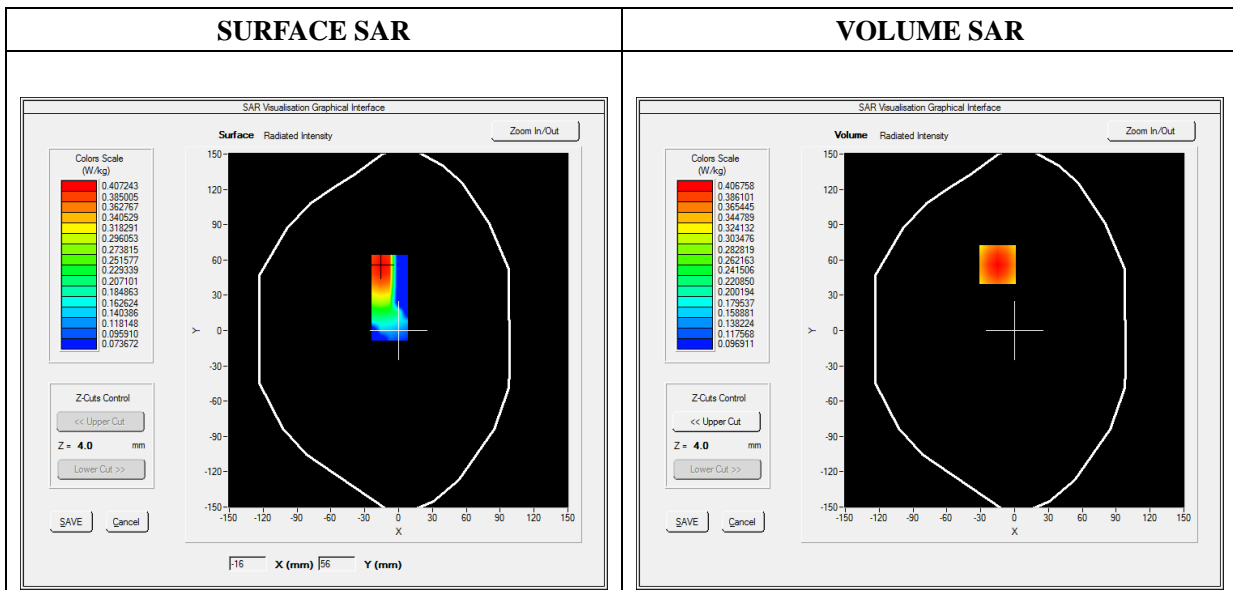

Maximum location: X=-15.00, Y=56.00

SAR Peak: 0.52 W/kg

SAR 10g (W/Kg)	0.281910
SAR 1g (W/Kg)	0.391790

Z (mm)	0.00	4.00	9.00	14.00	19.00
SAR (W/Kg)	0.5168	0.4068	0.3015	0.2253	0.1702

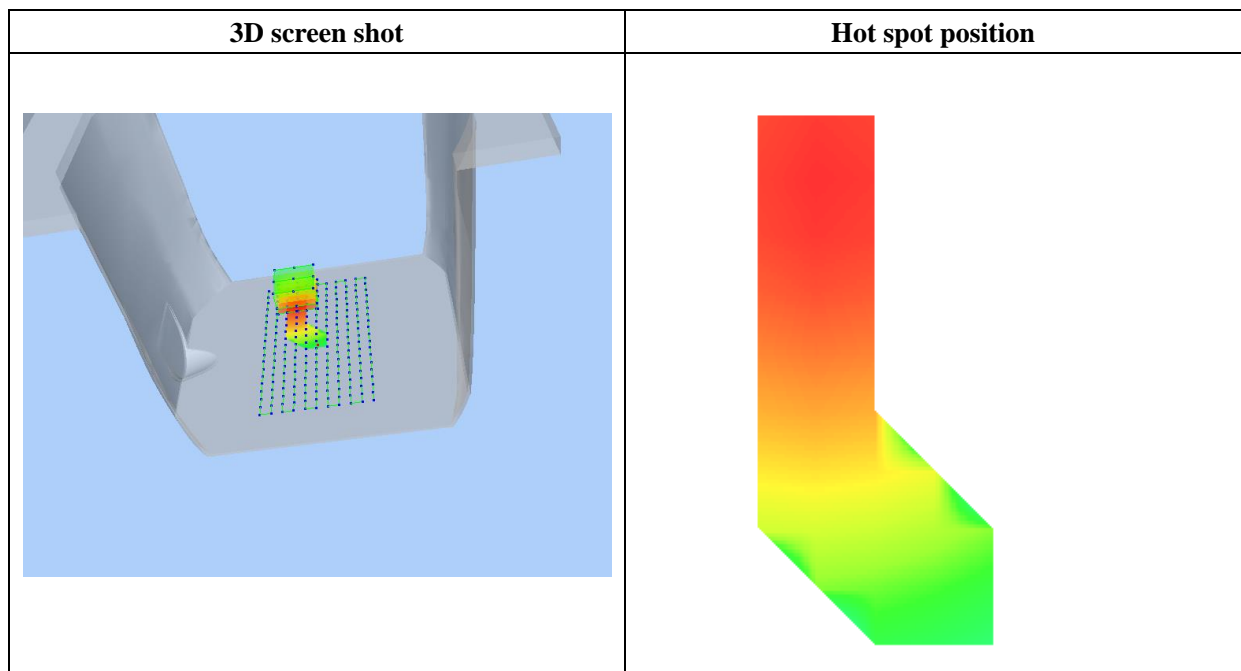
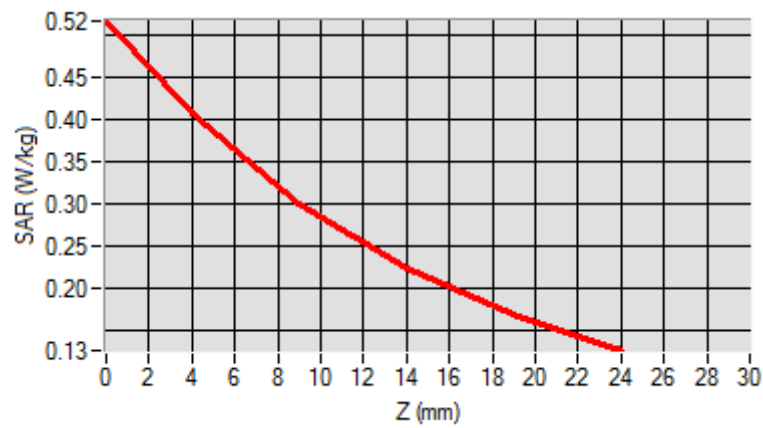

MEASUREMENT 3

Type: Phone measurement (Complete)

Date of measurement: 08/13/2019

Measurement duration: 12 minutes 3 seconds

E-field Probe: SSE5 - SN 09/13 EP168; ConvF: 6.35; Calibrated: 05/22/2019

A. Experimental conditions

Area Scan	dx=8mm dy=8mm
Zoom Scan	dx=8mm dy=8mm dz=5mm
Phantom	Flat plane
Device Position	Front
Band	LTE Band 2
Channels	QPSK, 20MHz, 1RB, Low
Signal	Duty Cycle 1:1

B. SAR Measurement Results

Frequency (MHz)	1860.000000
Relative Permittivity (real part)	38.560124
Conductivity (S/m)	1.380369
Power Variation (%)	1.743564
Ambient Temperature	21.1
Liquid Temperature	21.3

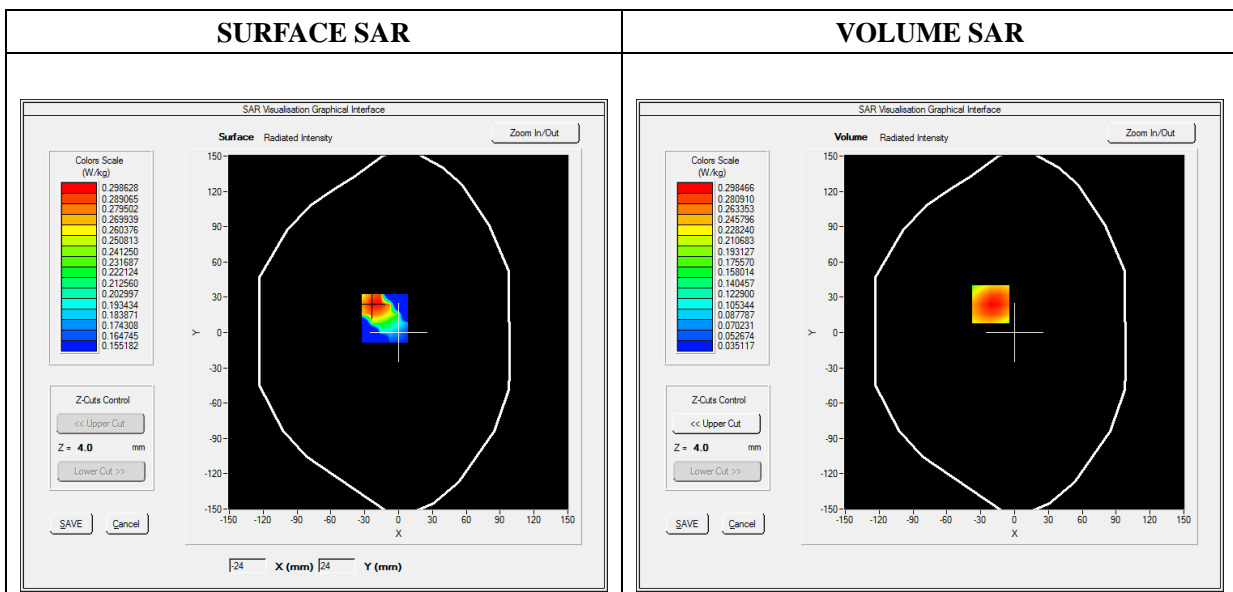

Maximum location: X=-21.00, Y=24.00

SAR Peak: 0.42 W/kg

SAR 10g (W/Kg)	0.182353
SAR 1g (W/Kg)	0.285468

Z (mm)	0.00	4.00	9.00	14.00	19.00
SAR (W/Kg)	0.4237	0.2985	0.1917	0.1254	0.0852

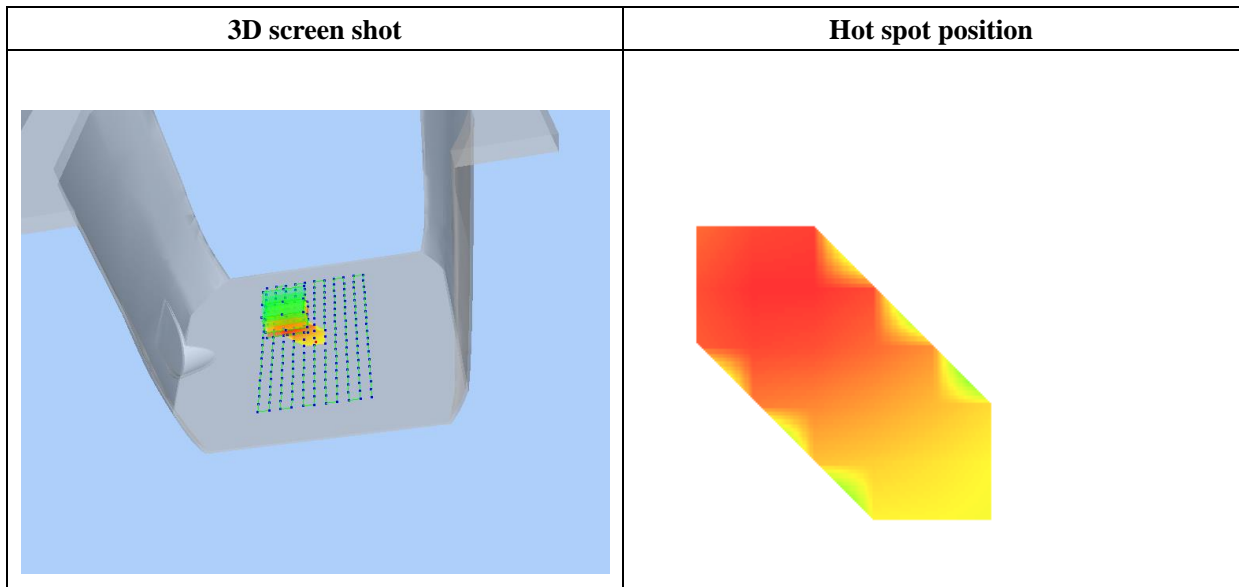
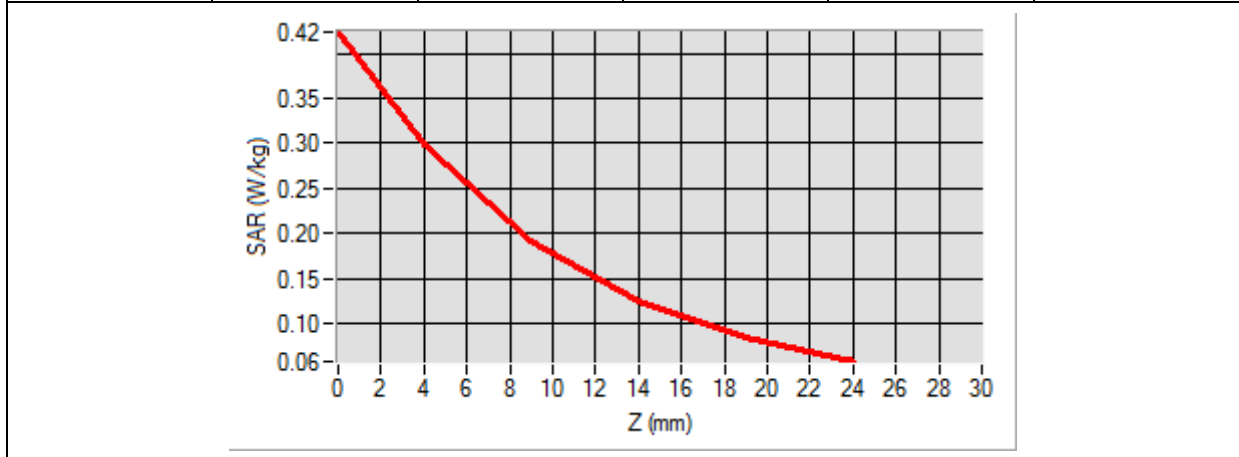

MEASUREMENT 5

Type: Phone measurement (Complete)

Date of measurement: 08/13/2019

Measurement duration: 12 minutes 3 seconds

E-field Probe: SSE5 - SN 09/13 EP168; ConvF: 5.84; Calibrated: 05/22/2019

A. Experimental conditions

Area Scan	dx=8mm dy=8mm
Zoom Scan	dx=8mm dy=8mm dz=5mm
Phantom	Flat plane
Device Position	Front
Band	LTE Band 4
Channels	QPSK, 20MHz, 1RB, Low
Signal	Duty Cycle 1:1

B. SAR Measurement Results

Frequency (MHz)	1720.000000
Relative Permittivity (real part)	39.025421
Conductivity (S/m)	1.370123
Power Variation (%)	1.374628
Ambient Temperature	21.1
Liquid Temperature	21.2

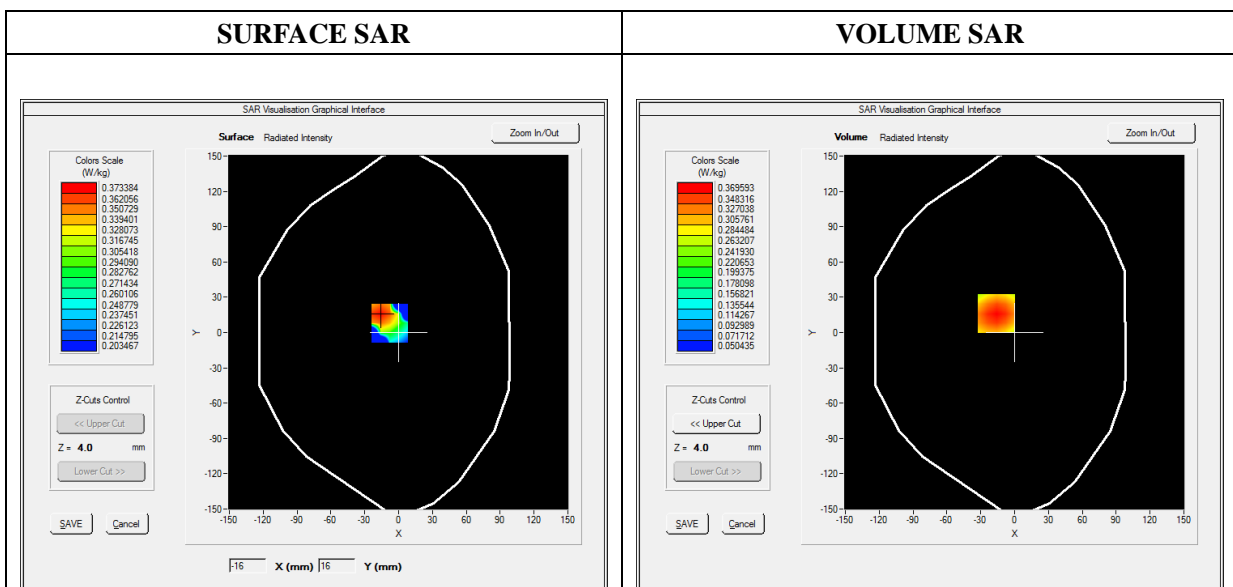



Maximum location: X=-16.00, Y=16.00

SAR Peak: 0.51 W/kg

SAR 10g (W/Kg)	0.229384
SAR 1g (W/Kg)	0.353548

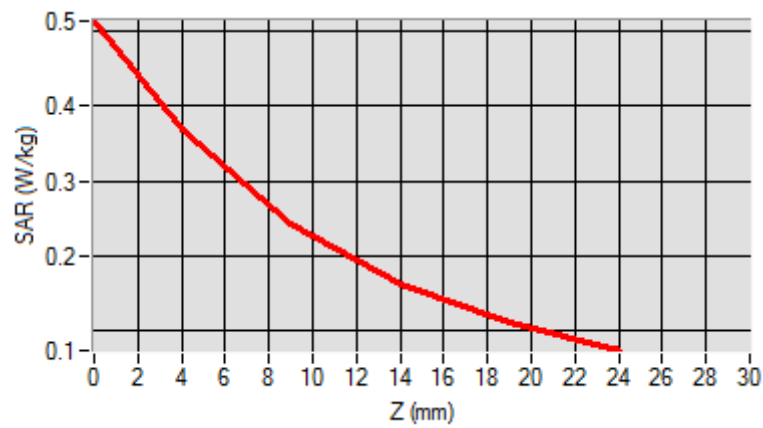
Z (mm)	0.00	4.00	9.00	14.00	19.00
SAR (W/Kg)	0.5142	0.3696	0.2430	0.1614	0.1096

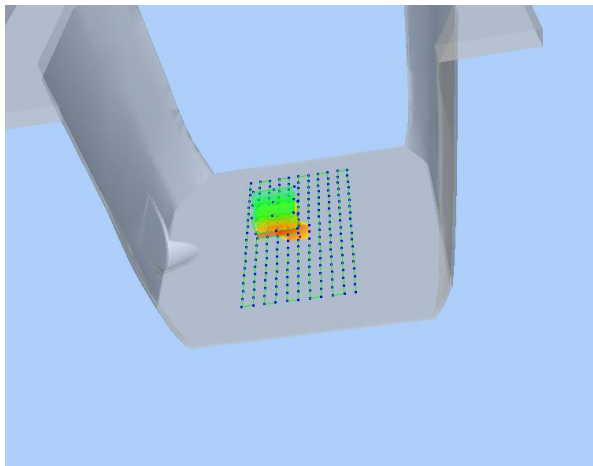

3D screen shot	Hot spot position
	

MEASUREMENT 7

Type: Phone measurement (Complete)

Date of measurement: 08/12/2019

Measurement duration: 12 minutes 3 seconds

E-field Probe: SSE5 - SN 09/13 EP168; ConvF: 6.93; Calibrated: 05/22/2019

A. Experimental conditions

Area Scan	dx=8mm dy=8mm
Zoom Scan	dx=8mm dy=8mm dz=5mm
Phantom	Flat plane
Device Position	Front
Band	LTE Band 5
Channels	QPSK, 10MHz, 1RB, Middle
Signal	Duty Cycle 1:1

B. SAR Measurement Results

Frequency (MHz)	836.500000
Relative Permittivity (real part)	41.110245
Conductivity (S/m)	0.871245
Power Variation (%)	0.924535
Ambient Temperature	21.1
Liquid Temperature	21.2

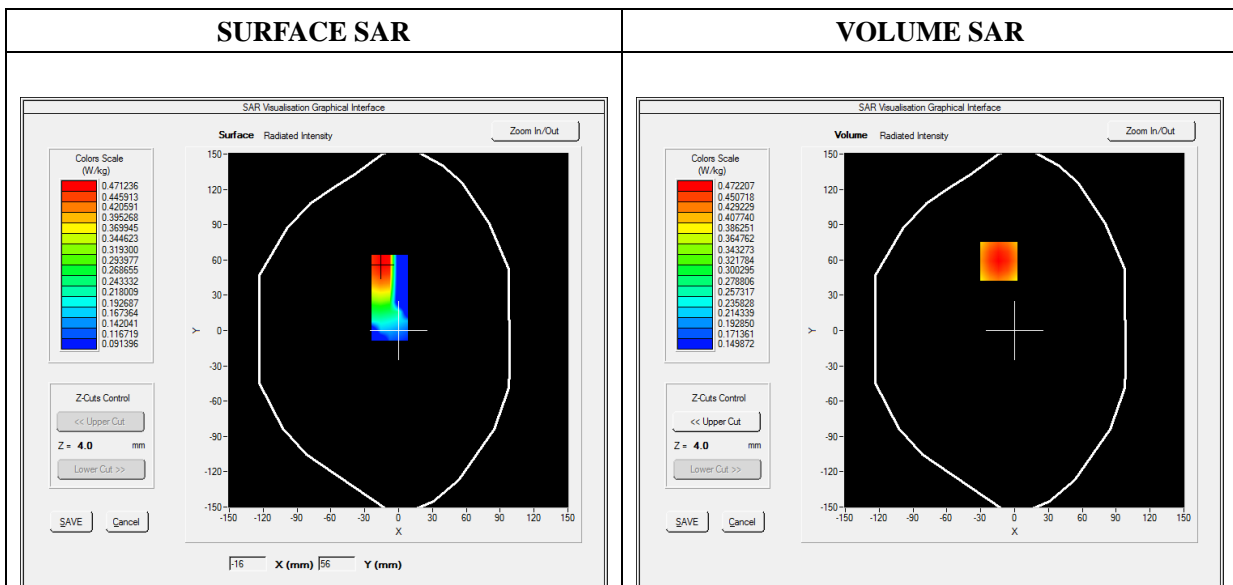

Maximum location: X=-14.00, Y=59.00

SAR Peak: 0.55 W/kg

SAR 10g (W/Kg)	0.352940
SAR 1g (W/Kg)	0.457350

Z (mm)	0.00	4.00	9.00	14.00	19.00
SAR (W/Kg)	0.5507	0.4722	0.3840	0.3062	0.2383

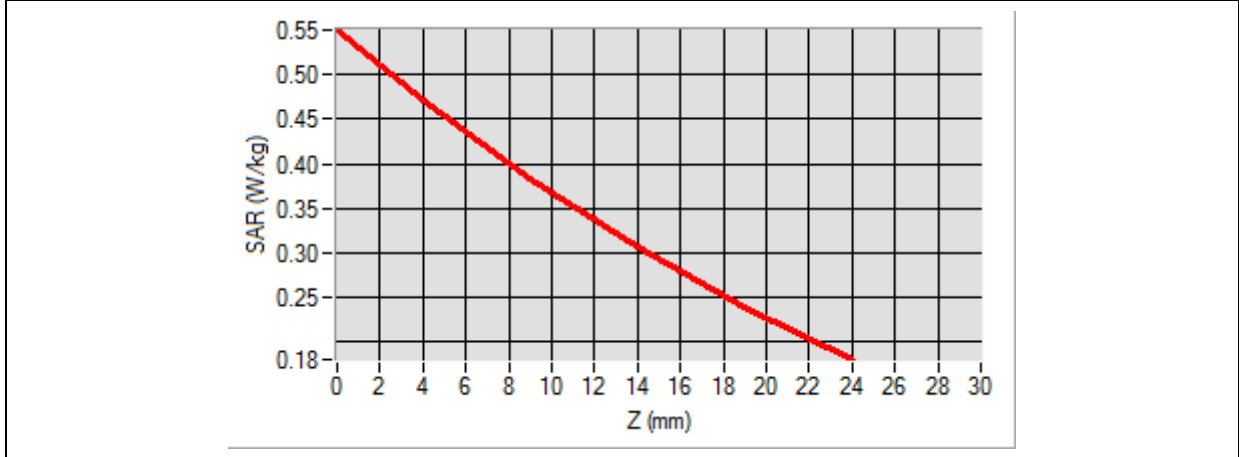

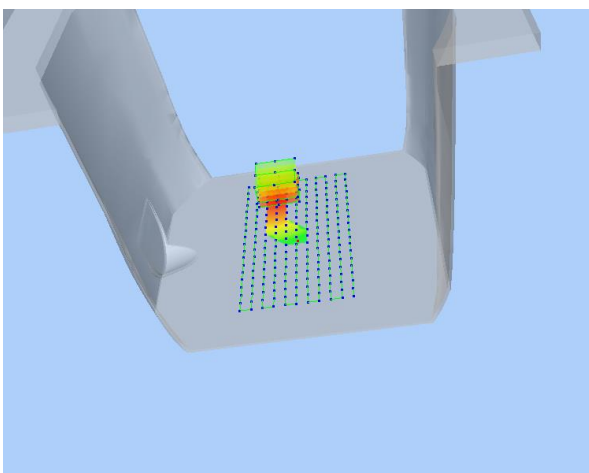
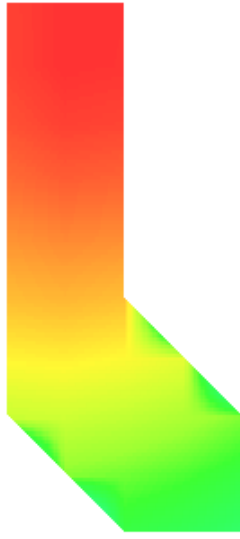
<p>3D screen shot</p>	<p>Hot spot position</p>
	

MEASUREMENT 9

Type: Phone measurement (Complete)

Date of measurement: 08/12/2019

Measurement duration: 12 minutes 3 seconds

E-field Probe: SSE5 - SN 09/13 EP168; ConvF: 6.99; Calibrated: 05/22/2019

A. Experimental conditions

Area Scan	dx=8mm dy=8mm
Zoom Scan	dx=8mm dy=8mm dz=5mm
Phantom	Flat plane
Device Position	Front
Band	LTE Band 12
Channels	QPSK, 10MHz, 1RB, Middle
Signal	Duty Cycle 1:1

B. SAR Measurement Results

Frequency (MHz)	707.500000
Relative Permittivity (real part)	41.320574
Conductivity (S/m)	0.862373
Power Variation (%)	0.924535
Ambient Temperature	21.1
Liquid Temperature	21.2

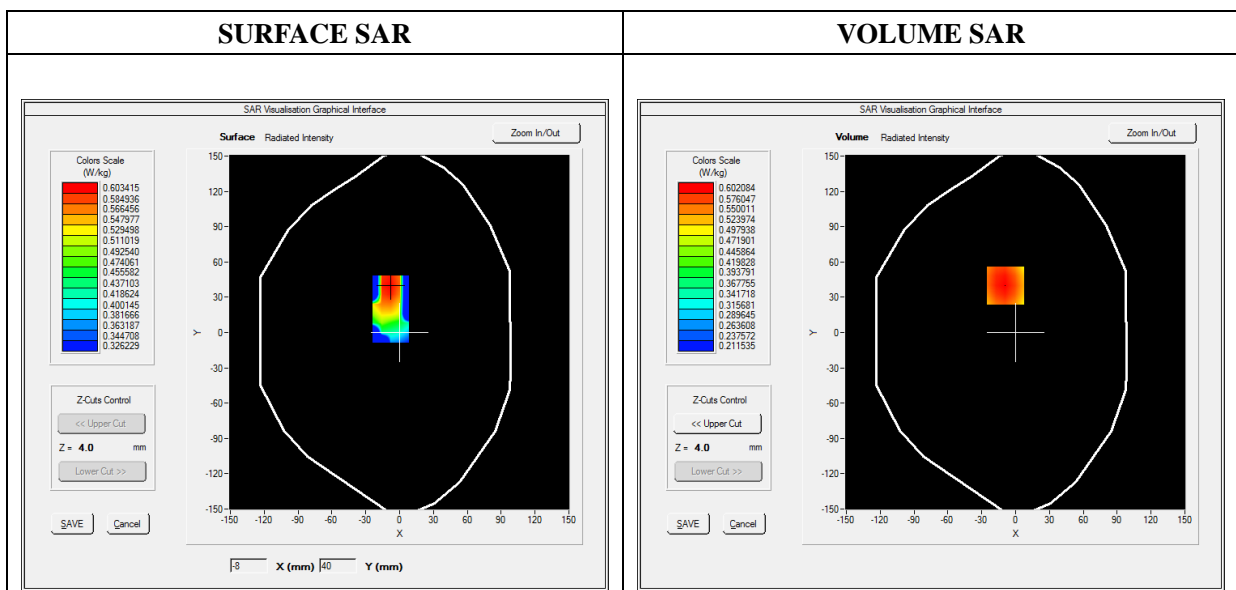



Maximum location: X=-9.00, Y=40.00

SAR Peak: 0.72 W/kg

SAR 10g (W/Kg)	0.460441
SAR 1g (W/Kg)	0.592642

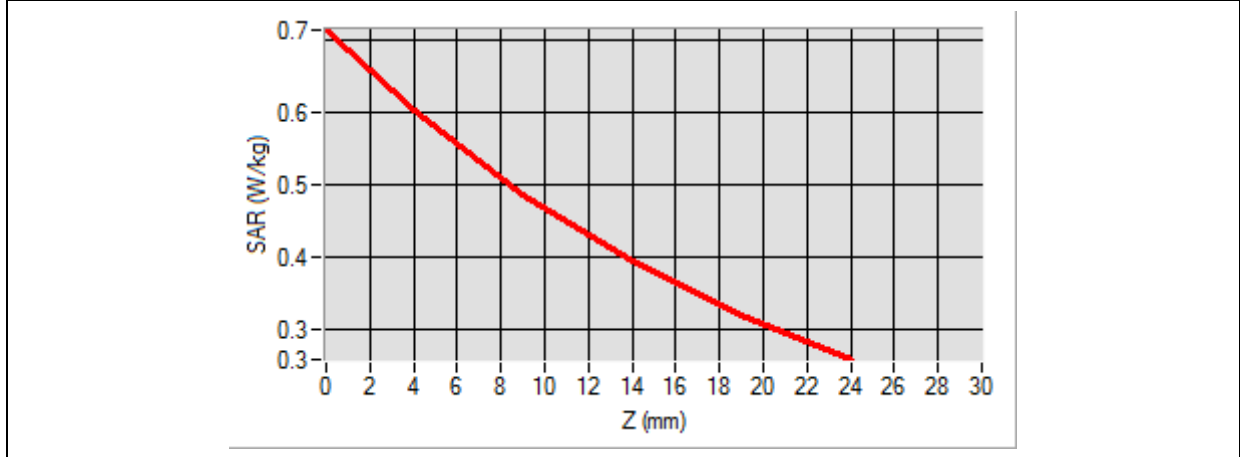
Z (mm)	0.00	4.00	9.00	14.00	19.00
SAR (W/Kg)	0.7144	0.6021	0.4861	0.3937	0.3196

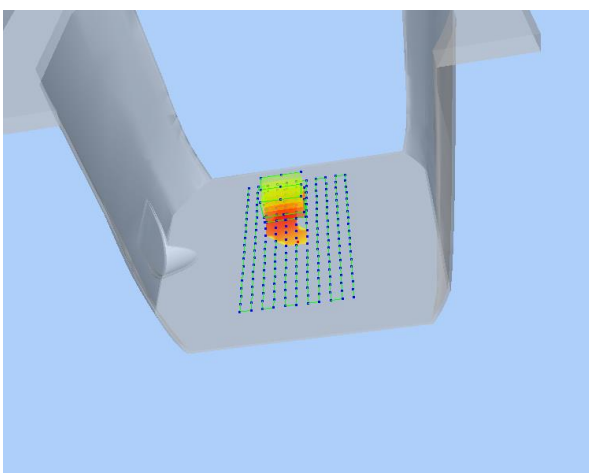

<p>3D screen shot</p>	<p>Hot spot position</p>
	

MEASUREMENT 11

Type: Phone measurement (Complete)

Date of measurement: 08/12/2019

Measurement duration: 12 minutes 3 seconds

E-field Probe: SSE5 - SN 09/13 EP168; ConvF: 6.99; Calibrated: 05/22/2019

A. Experimental conditions

Area Scan	dx=8mm dy=8mm
Zoom Scan	dx=8mm dy=8mm dz=5mm
Phantom	Flat plane
Device Position	Front
Band	LTE Band 17
Channels	QPSK, 10MHz, 1RB, Low
Signal	Duty Cycle 1:1

B. SAR Measurement Results

Frequency (MHz)	709.000000
Relative Permittivity (real part)	41.320574
Conductivity (S/m)	0.862373
Power Variation (%)	0.924452
Ambient Temperature	21.1
Liquid Temperature	21.2

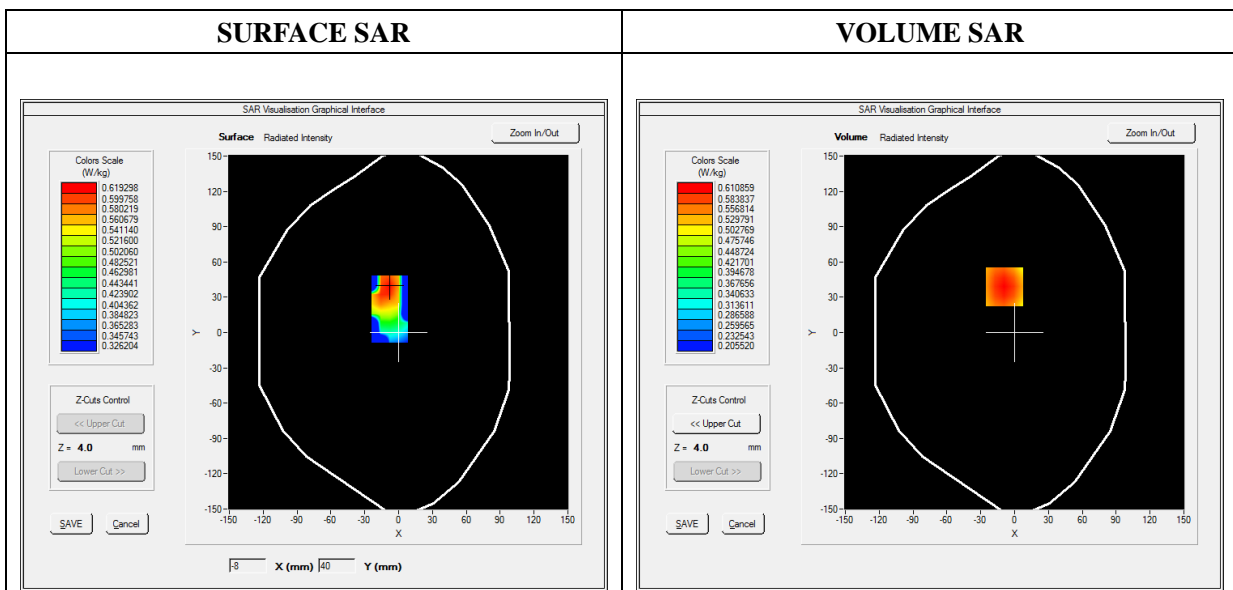



Maximum location: X=-9.00, Y=39.00

SAR Peak: 0.77 W/kg

SAR 10g (W/Kg)	0.469205
SAR 1g (W/Kg)	0.625752

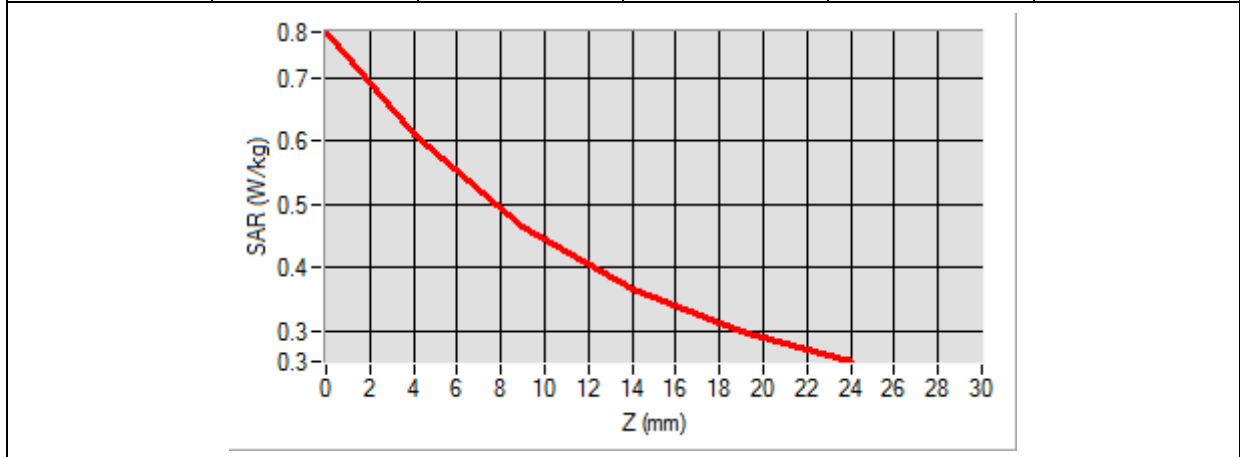
Z (mm)	0.00	4.00	9.00	14.00	19.00
SAR (W/Kg)	0.7721	0.6109	0.4636	0.3650	0.3003

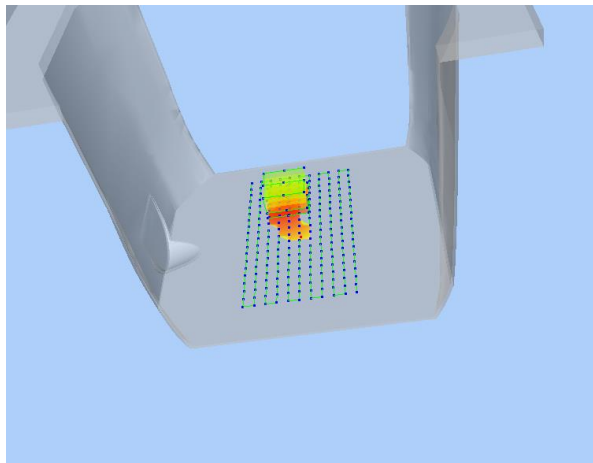

3D screen shot	Hot spot position
	

MEASUREMENT 13

Type: Phone measurement (Complete)

Date of measurement: 08/13/2019

Measurement duration: 12 minutes 3 seconds

E-field Probe: SSE5 - SN 09/13 EP168; ConvF: 6.55; Calibrated: 05/22/2019

A. Experimental conditions

Area Scan	dx=8mm dy=8mm
Zoom Scan	dx=8mm dy=8mm dz=5mm
Phantom	Flat Plane
Device Position	Back
Band	WCDMA1900_RMC
Channels	High
Signal	Duty Cycle 1:1

B. SAR Measurement Results

Frequency (MHz)	1907.600000
Relative Permittivity (real part)	52.420415
Conductivity (S/m)	1.501966
Power Variation (%)	1.789272
Ambient Temperature	21.1
Liquid Temperature	21.3

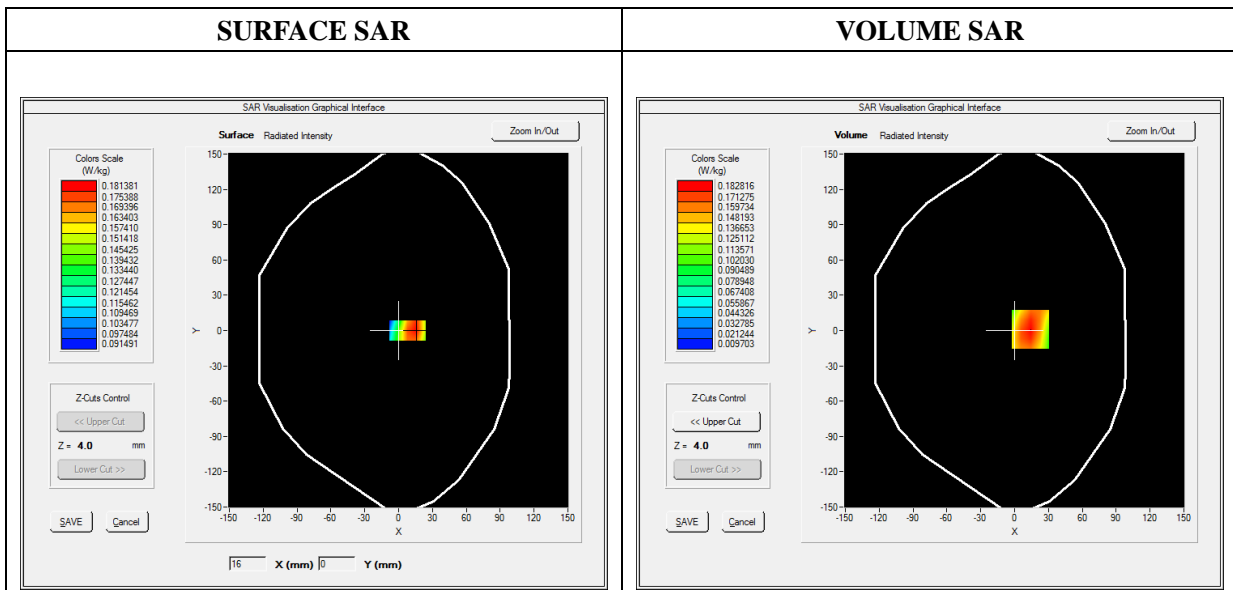



Maximum location: X=14.00, Y=1.00

SAR Peak: 0.30 W/kg

SAR 10g (W/Kg)	0.097108
SAR 1g (W/Kg)	0.173963

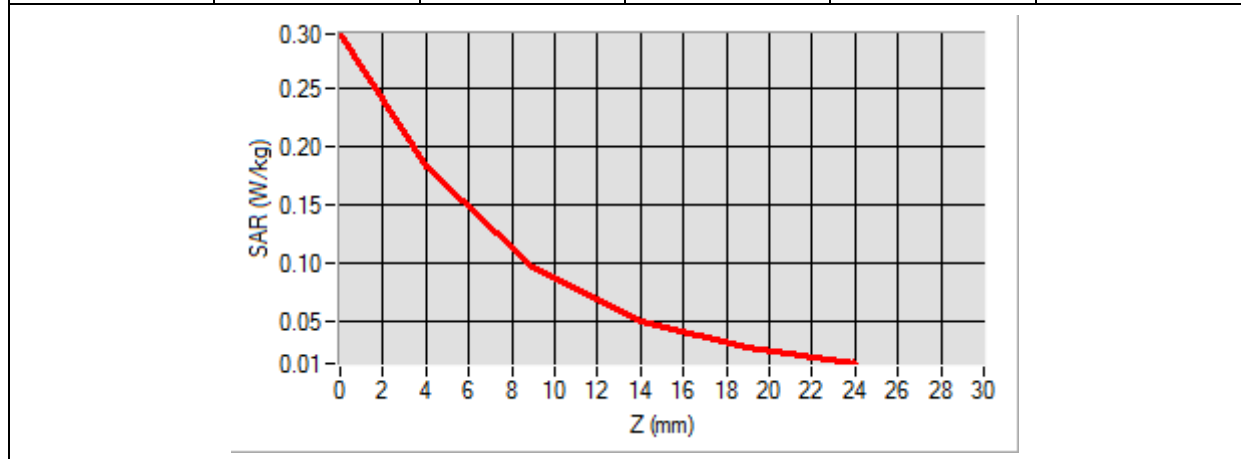
Z (mm)	0.00	4.00	9.00	14.00	19.00
SAR (W/Kg)	0.2956	0.1828	0.0966	0.0508	0.0278

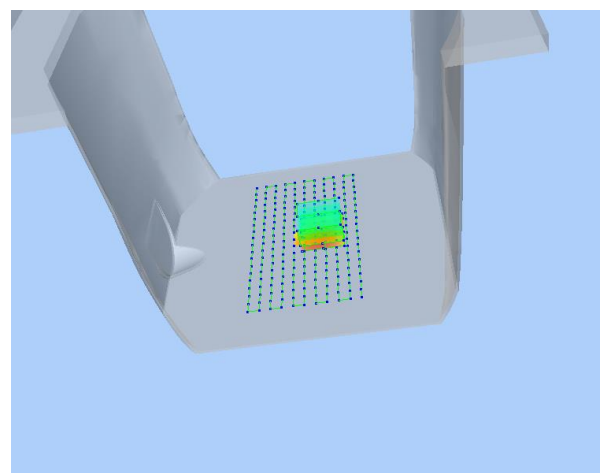

3D screen shot	Hot spot position
	

MEASUREMENT 15

Type: Phone measurement (Complete)

Date of measurement: 08/12/2019

Measurement duration: 12 minutes 3 seconds

E-field Probe: SSE5 - SN 09/13 EP168; ConvF: 7.13; Calibrated: 05/22/2019

A. Experimental conditions

Area Scan	dx=8mm dy=8mm
Zoom Scan	dx=8mm dy=8mm dz=5mm
Phantom	Flat Plane
Device Position	Back
Band	WCDMA850_RMC
Channels	Low
Signal	Duty Cycle 1:1

B. SAR Measurement Results

Frequency (MHz)	826.400000
Relative Permittivity (real part)	54.851214
Conductivity (S/m)	0.951454
Power Variation (%)	2.341234
Ambient Temperature	21.1
Liquid Temperature	21.3

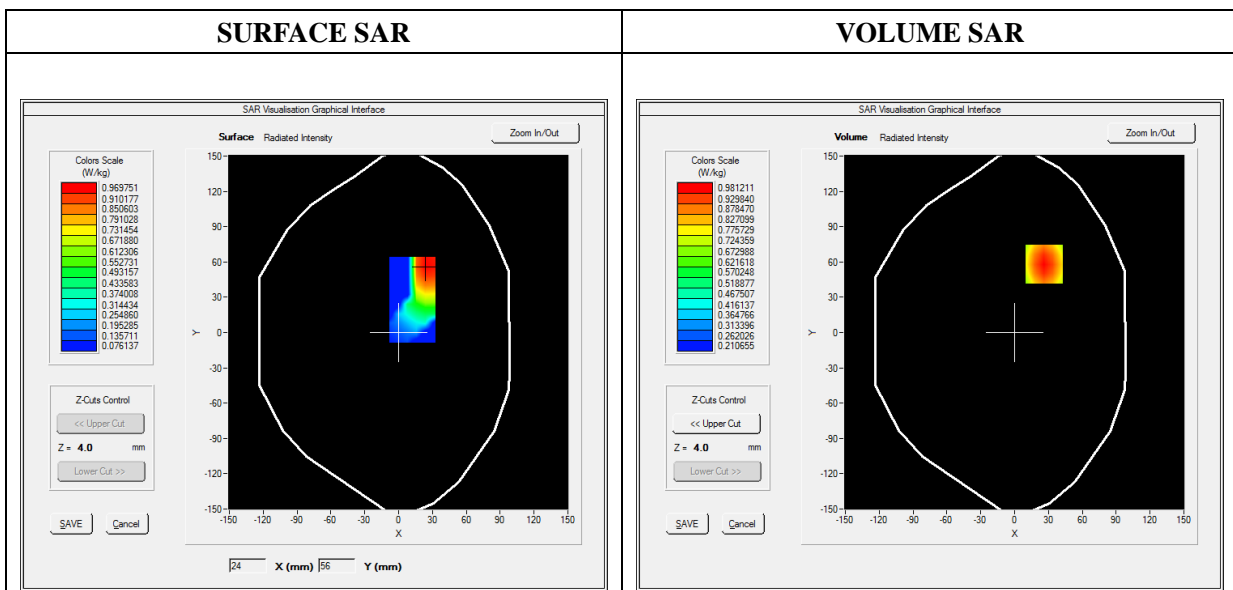

Maximum location: X=26.00, Y=58.00

SAR Peak: 1.24 W/kg

SAR 10g (W/Kg)	0.671510
SAR 1g (W/Kg)	0.946483

Z (mm)	0.00	4.00	9.00	14.00	19.00
SAR (W/Kg)	1.2415	0.9812	0.7303	0.5469	0.4127

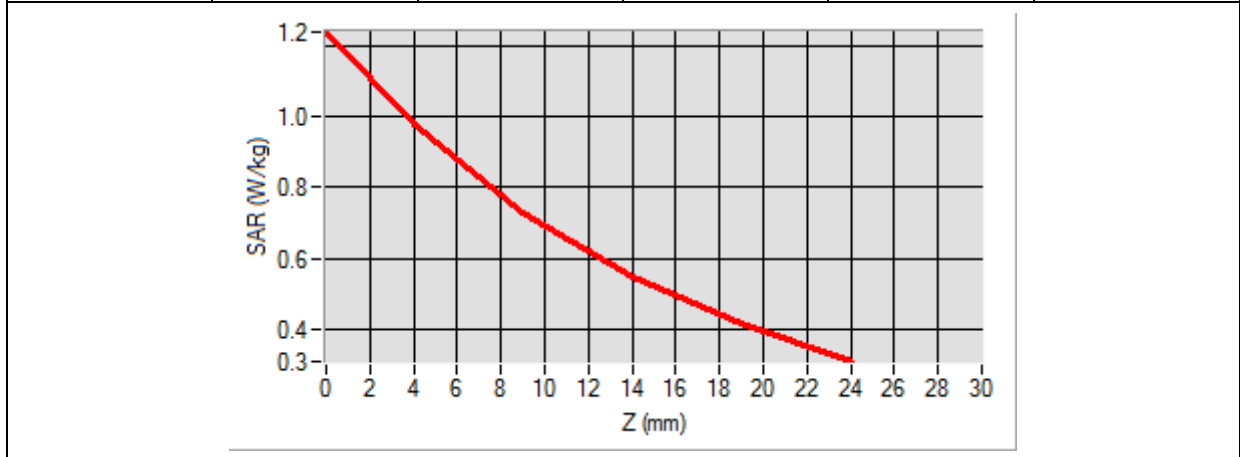

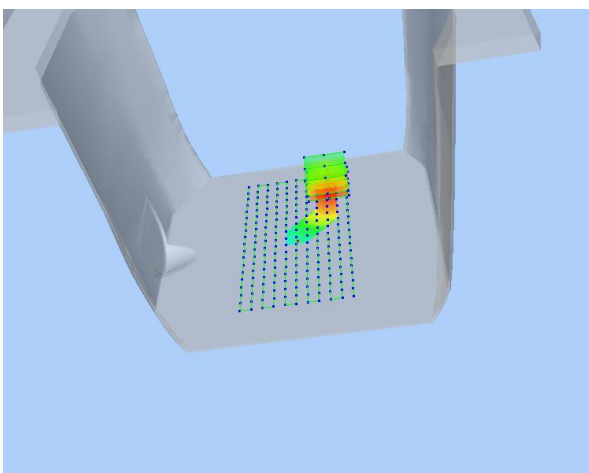
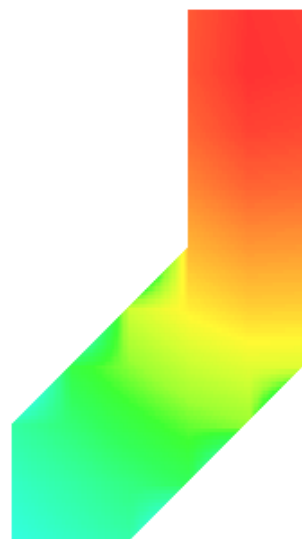
<p>3D screen shot</p>	<p>Hot spot position</p>
	

MEASUREMENT 17

Type: Phone measurement (Complete)

Date of measurement: 08/13/2019

Measurement duration: 12 minutes 3 seconds

E-field Probe: SSE5 - SN 09/13 EP168; ConvF: 6.55; Calibrated: 05/22/2019

A. Experimental conditions

Area Scan	dx=8mm dy=8mm
Zoom Scan	dx=8mm dy=8mm dz=5mm
Phantom	Flat Plane
Device Position	Back
Band	LTE Band 2
Channels	QPSK, 20MHz, 1RB,Low
Signal	Duty Cycle 1:1

B. SAR Measurement Results

Frequency (MHz)	1860.000000
Relative Permittivity (real part)	52.420415
Conductivity (S/m)	1.501966
Power Variation (%)	1.523573
Ambient Temperature	21.1
Liquid Temperature	21.3

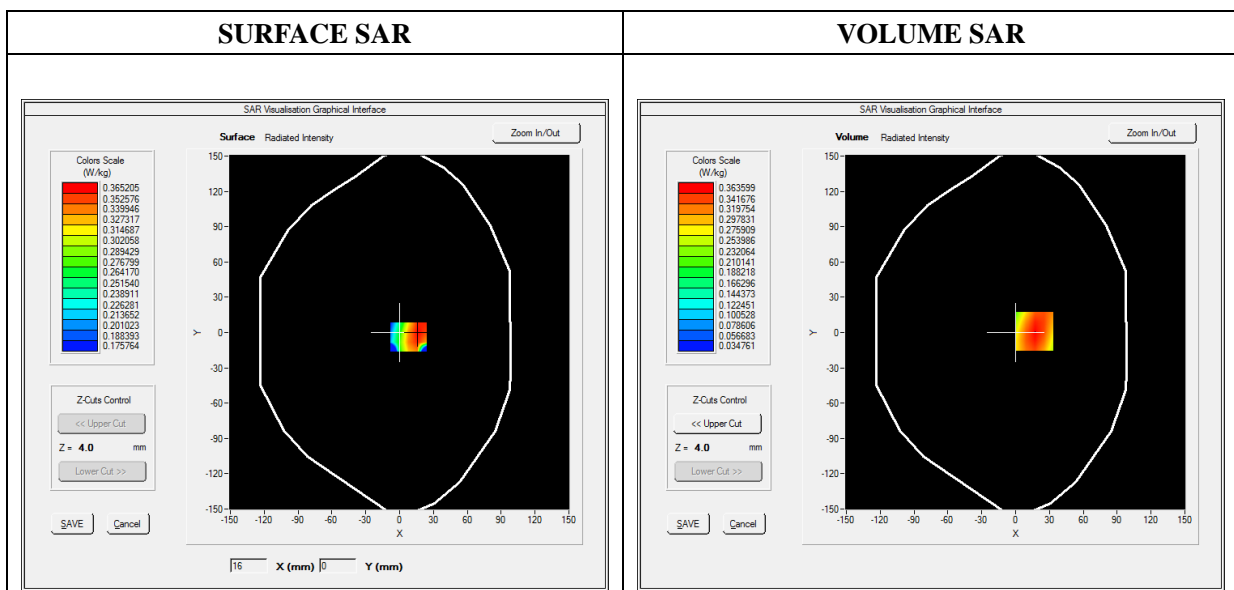

Maximum location: X=17.00, Y=1.00

SAR Peak: 0.54 W/kg

SAR 10g (W/Kg)	0.212572
SAR 1g (W/Kg)	0.346992

Z (mm)	0.00	4.00	9.00	14.00	19.00
SAR (W/Kg)	0.5373	0.3636	0.2194	0.1330	0.0826

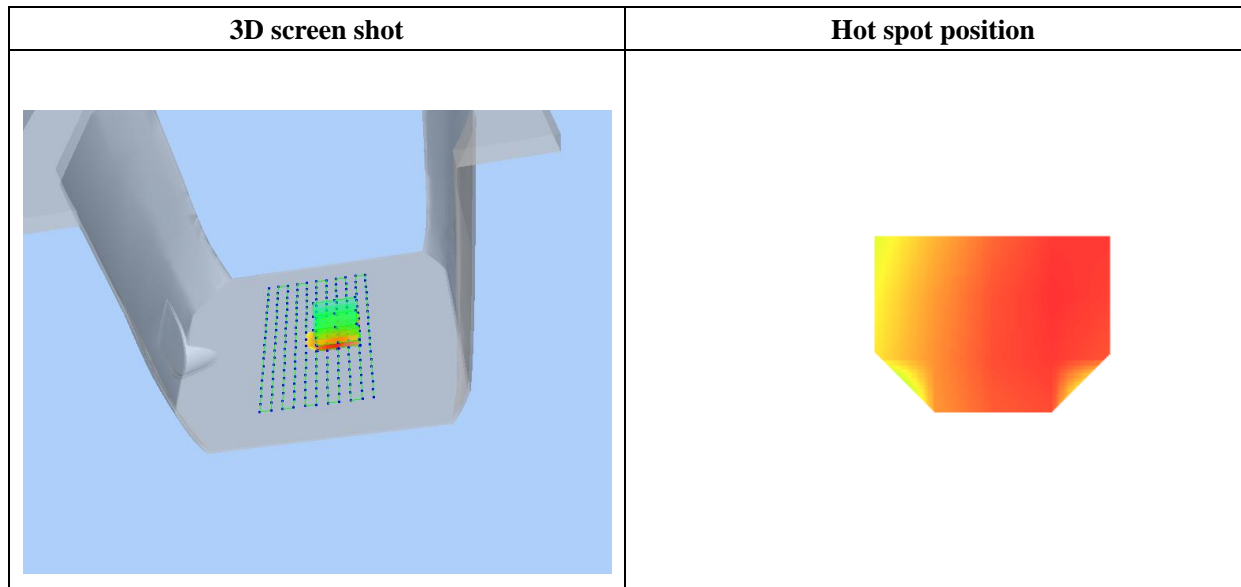
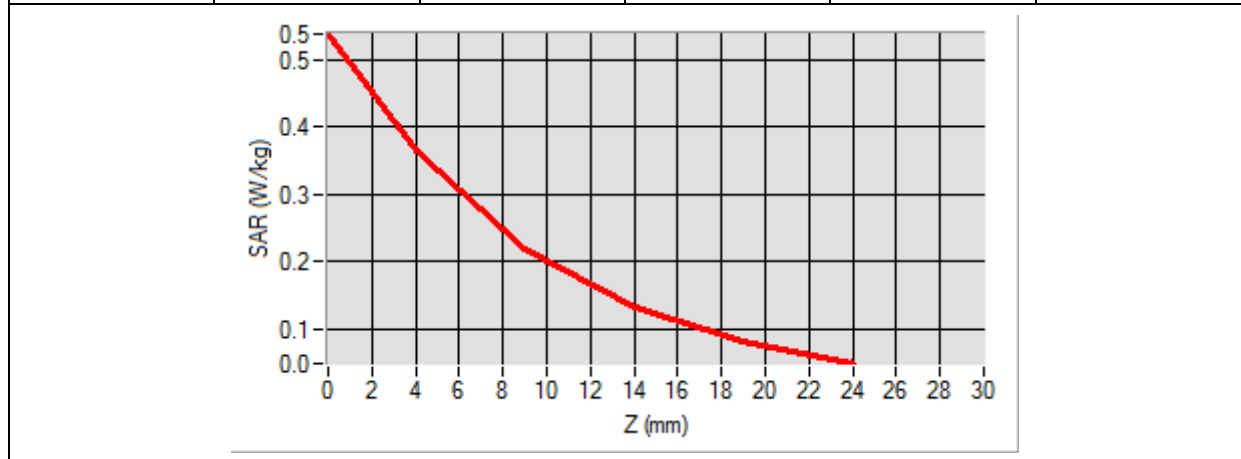

MEASUREMENT 19

Type: Phone measurement (Complete)

Date of measurement: 08/13/2019

Measurement duration: 12 minutes 3 seconds

E-field Probe: SSE5 - SN 09/13 EP168; ConvF: 6.06; Calibrated: 05/22/2019

A. Experimental conditions

Area Scan	dx=8mm dy=8mm
Zoom Scan	dx=8mm dy=8mm dz=5mm
Phantom	Flat Plane
Device Position	Back
Band	LTE Band 4
Channels	QPSK, 20MHz, 1RB, Low
Signal	Duty Cycle 1:1

B. SAR Measurement Results

Frequency (MHz)	1720.000000
Relative Permittivity (real part)	51.220432
Conductivity (S/m)	1.460124
Power Variation (%)	0.858383
Ambient Temperature	21.1
Liquid Temperature	21.2

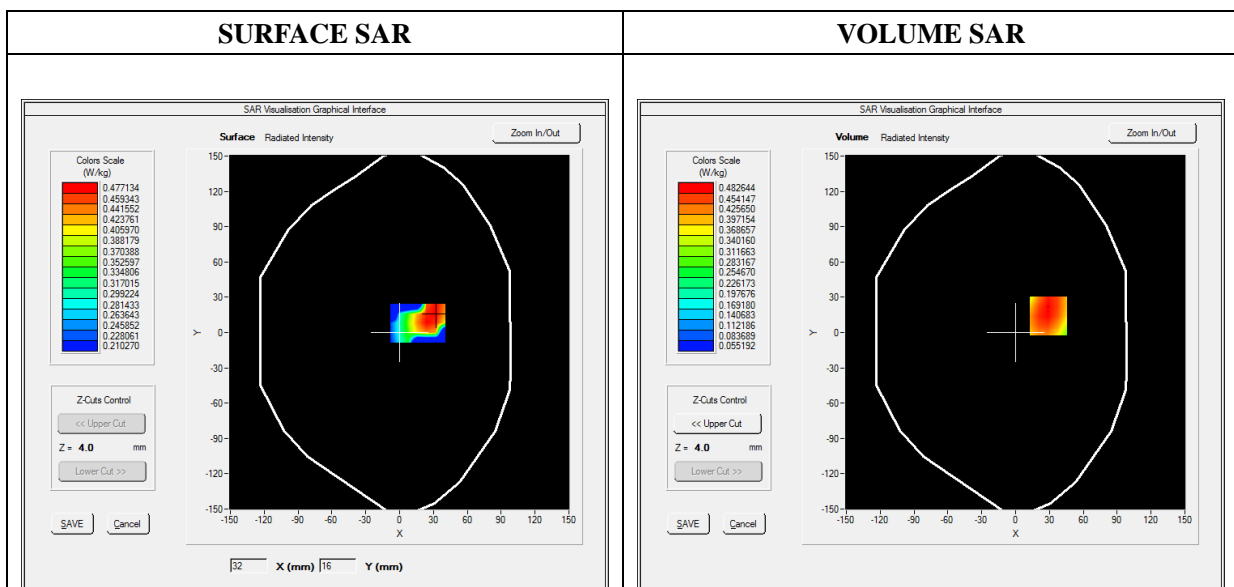



Maximum location: X=29.00, Y=14.00

SAR Peak: 0.66 W/kg

SAR 10g (W/Kg)	0.304775
SAR 1g (W/Kg)	0.463800

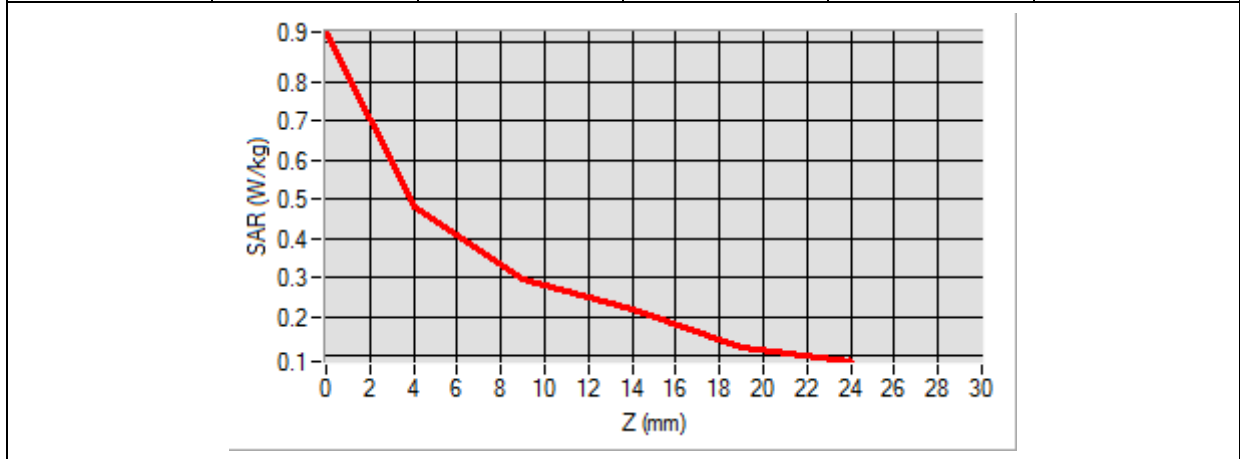
Z (mm)	0.00	4.00	9.00	14.00	19.00
SAR (W/Kg)	0.9271	0.4826	0.2971	0.2186	0.1206

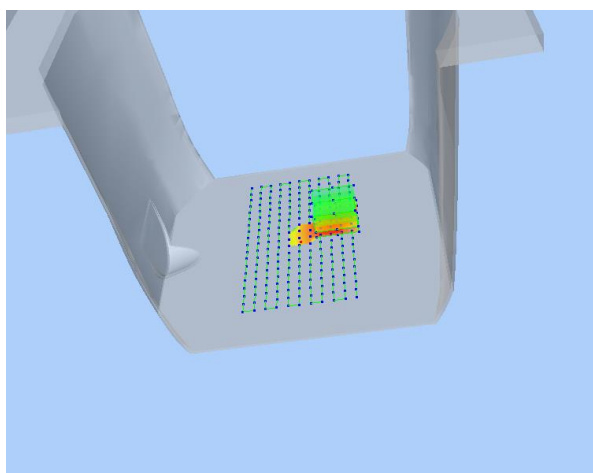

<p>3D screen shot</p>	<p>Hot spot position</p>
	

MEASUREMENT 23

Type: Phone measurement (Complete)

Date of measurement: 08/12/2019

Measurement duration: 12 minutes 3 seconds

E-field Probe: SSE5 - SN 09/13 EP168; ConvF: 7.13; Calibrated: 05/22/2019

A. Experimental conditions

Area Scan	dx=8mm dy=8mm
Zoom Scan	dx=8mm dy=8mm dz=5mm
Phantom	Flat Plane
Device Position	Back
Band	LTE Band 5
Channels	QPSK, 10MHz, 1RB, High
Signal	Duty Cycle 1:1

B. SAR Measurement Results

Frequency (MHz)	844.000000
Relative Permittivity (real part)	54.851214
Conductivity (S/m)	0.951454
Power Variation (%)	1.037332
Ambient Temperature	21.1
Liquid Temperature	21.2

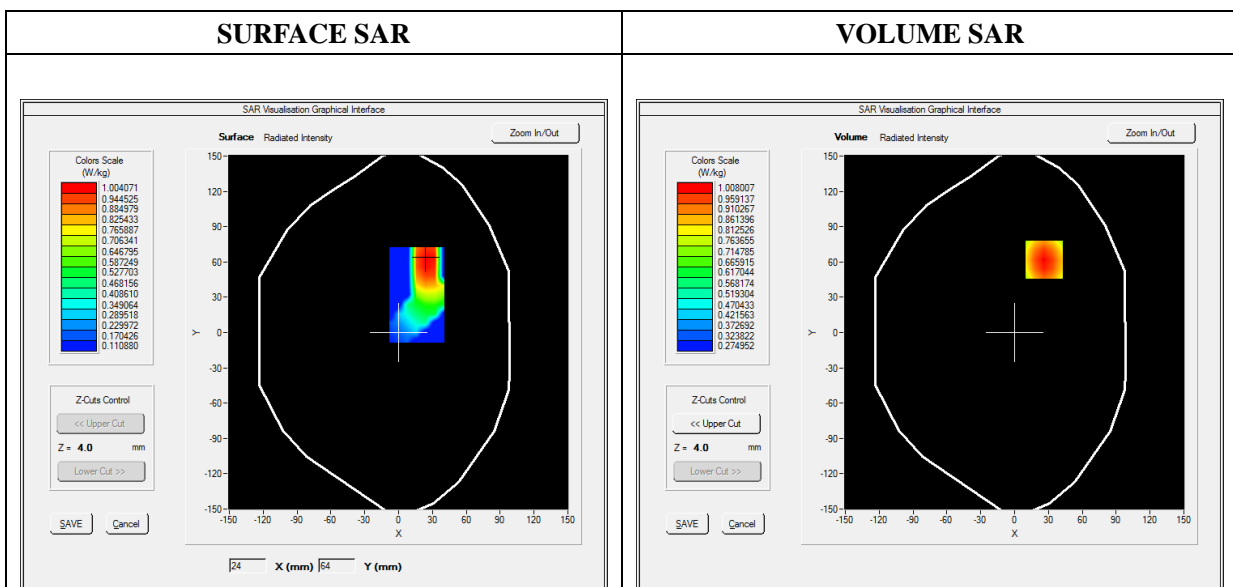

Maximum location: X=26.00, Y=62.00

SAR Peak: 1.19 W/kg

SAR 10g (W/Kg)	0.735133
SAR 1g (W/Kg)	0.972480

Z (mm)	0.00	4.00	9.00	14.00	19.00
SAR (W/Kg)	1.1851	1.0080	0.8124	0.6436	0.4987

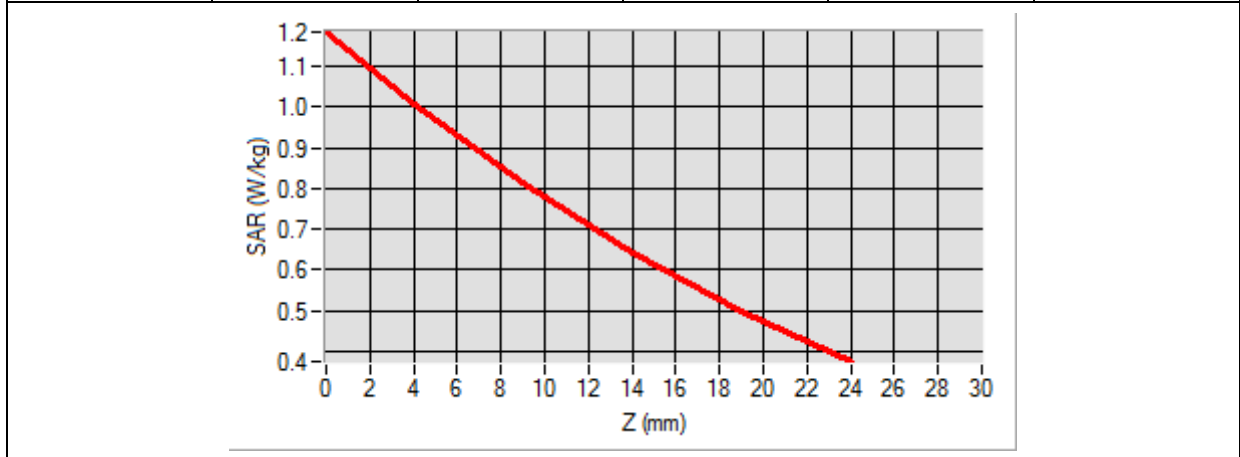

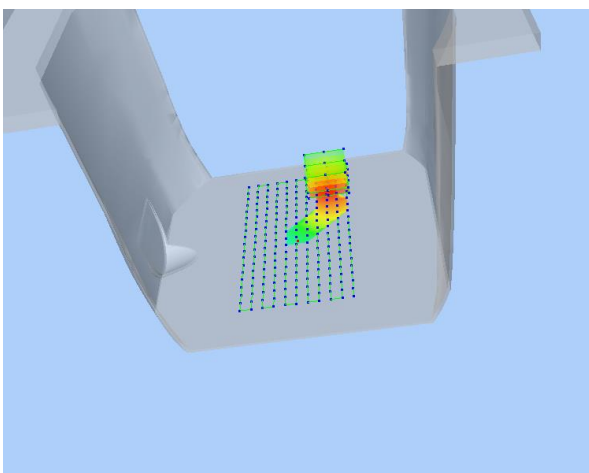
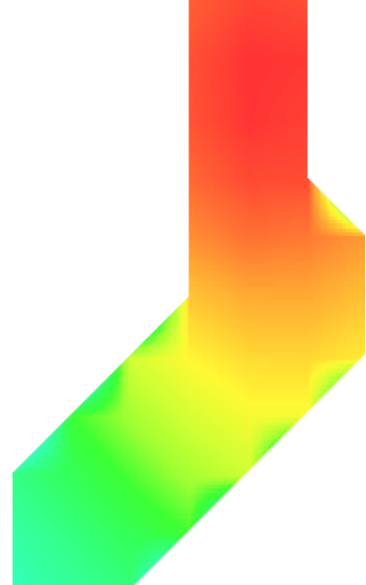
<p>3D screen shot</p>	<p>Hot spot position</p>
	

MEASUREMENT 27

Type: Phone measurement (Complete)

Date of measurement: 08/12/2019

Measurement duration: 12 minutes 3 seconds

E-field Probe: SSE5 - SN 09/13 EP168; ConvF: 7.28; Calibrated: 05/22/2019

A. Experimental conditions

Area Scan	dx=8mm dy=8mm
Zoom Scan	dx=8mm dy=8mm dz=5mm
Phantom	Flat Plane
Device Position	Back
Band	LTE Band 12
Channels	QPSK, 10MHz, 1RB, High
Signal	Duty Cycle 1:1

B. SAR Measurement Results

Frequency (MHz)	711.000000
Relative Permittivity (real part)	54.964739
Conductivity (S/m)	0.931048
Power Variation (%)	3.672346
Ambient Temperature	21.1
Liquid Temperature	21.2

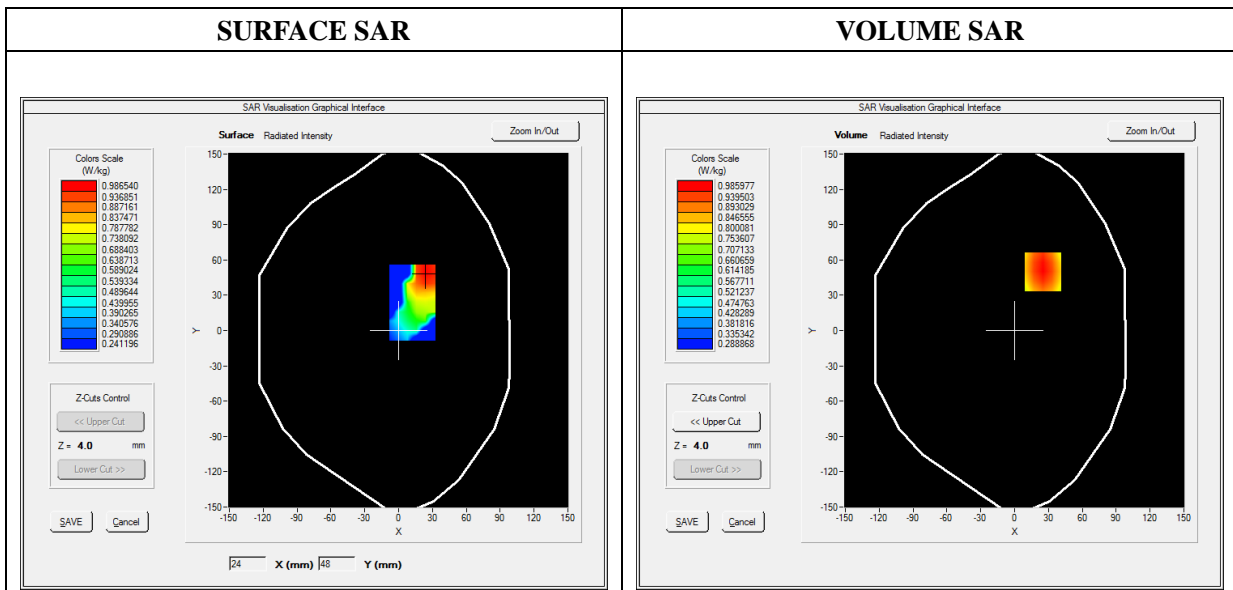

Maximum location: X=25.00, Y=50.00

SAR Peak: 1.24 W/kg

SAR 10g (W/Kg)	0.728795
SAR 1g (W/Kg)	0.964887

Z (mm)	0.00	4.00	9.00	14.00	19.00
SAR (W/Kg)	1.2103	0.9860	0.7705	0.6150	0.5030

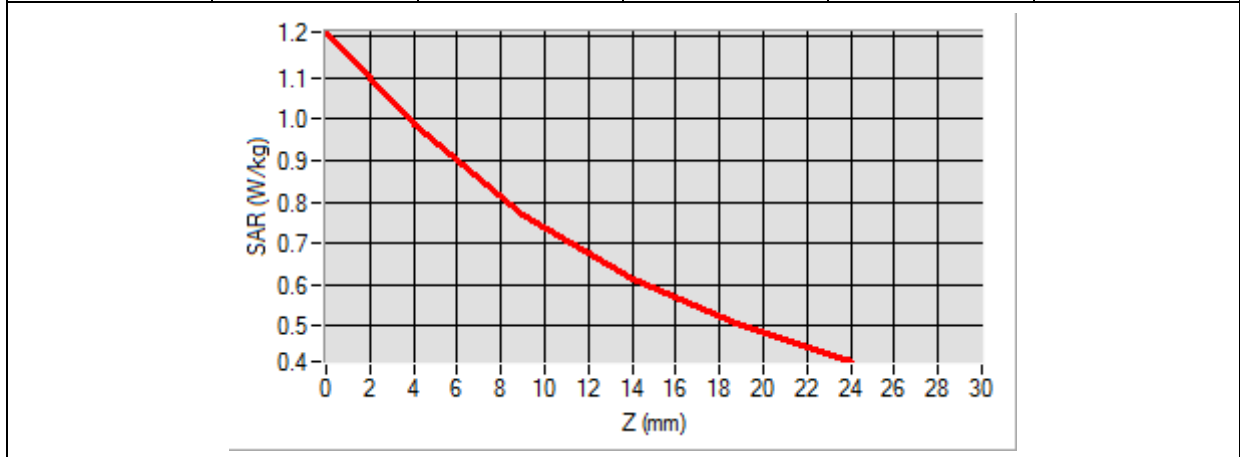

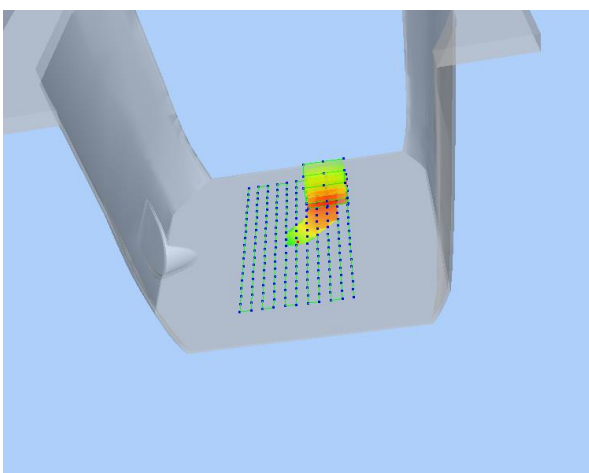
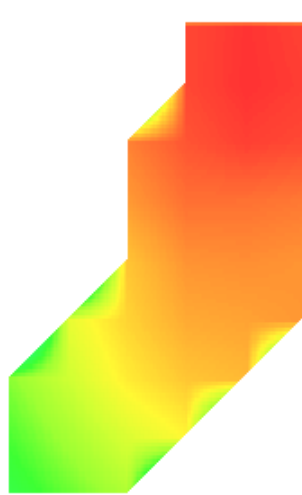
<p>3D screen shot</p>	<p>Hot spot position</p>
	

MEASUREMENT 31

Type: Phone measurement (Complete)

Date of measurement: 08/12/2019

Measurement duration: 12 minutes 3 seconds

E-field Probe: SSE5 - SN 09/13 EP168; ConvF: 7.28; Calibrated: 05/22/2019

A. Experimental conditions

Area Scan	dx=8mm dy=8mm
Zoom Scan	dx=8mm dy=8mm dz=5mm
Phantom	Flat Plane
Device Position	Back
Band	LTE Band 17
Channels	QPSK, 10MHz, 1RB, High
Signal	Duty Cycle 1:1

B. SAR Measurement Results

Frequency (MHz)	711.000000
Relative Permittivity (real part)	54.964739
Conductivity (S/m)	0.931048
Power Variation (%)	3.108329
Ambient Temperature	21.1
Liquid Temperature	21.2

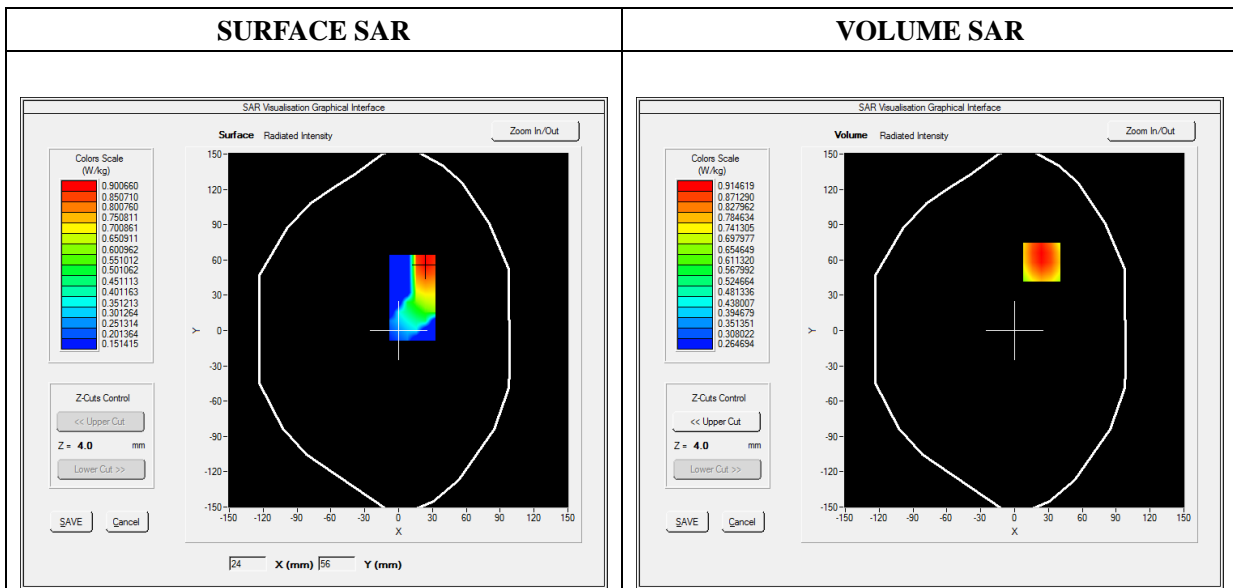

Maximum location: X=24.00, Y=58.00

SAR Peak: 1.17 W/kg

SAR 10g (W/Kg)	0.681897
SAR 1g (W/Kg)	0.933973

Z (mm)	0.00	4.00	9.00	14.00	19.00
SAR (W/Kg)	1.4524	0.9146	0.6494	0.5280	0.4086

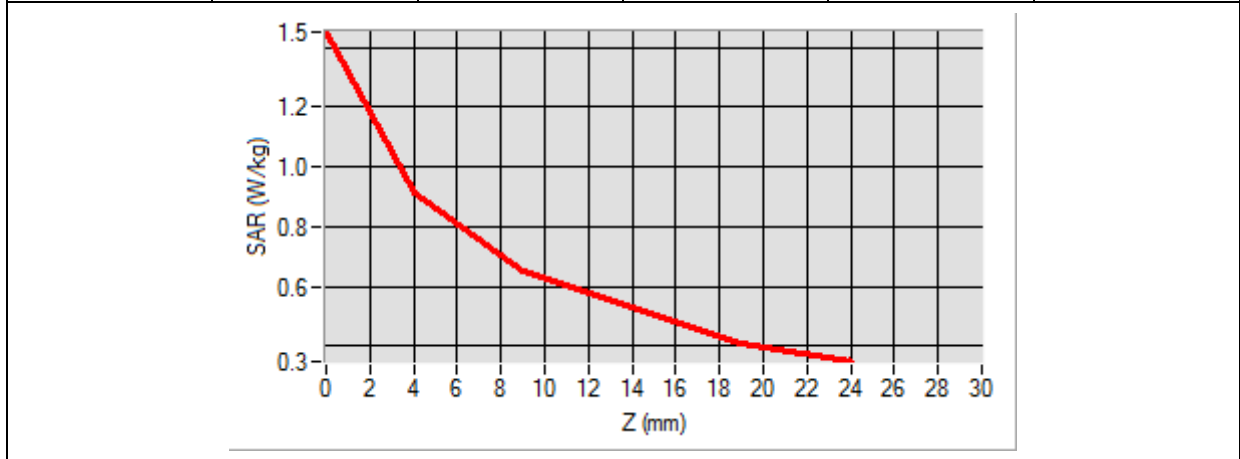

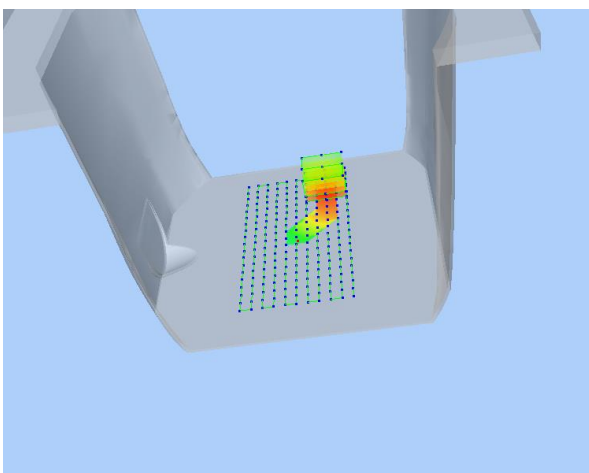
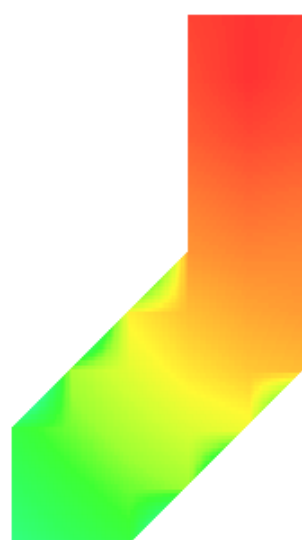
<p>3D screen shot</p>	<p>Hot spot position</p>
	

Annex C. EUT Photos

EUT View Front



EUT View Back



Antenna View



Annex D. Test Setup Photos

Head Exposure Conditions

Front-of-face



Body Exposure Conditions

Body Back

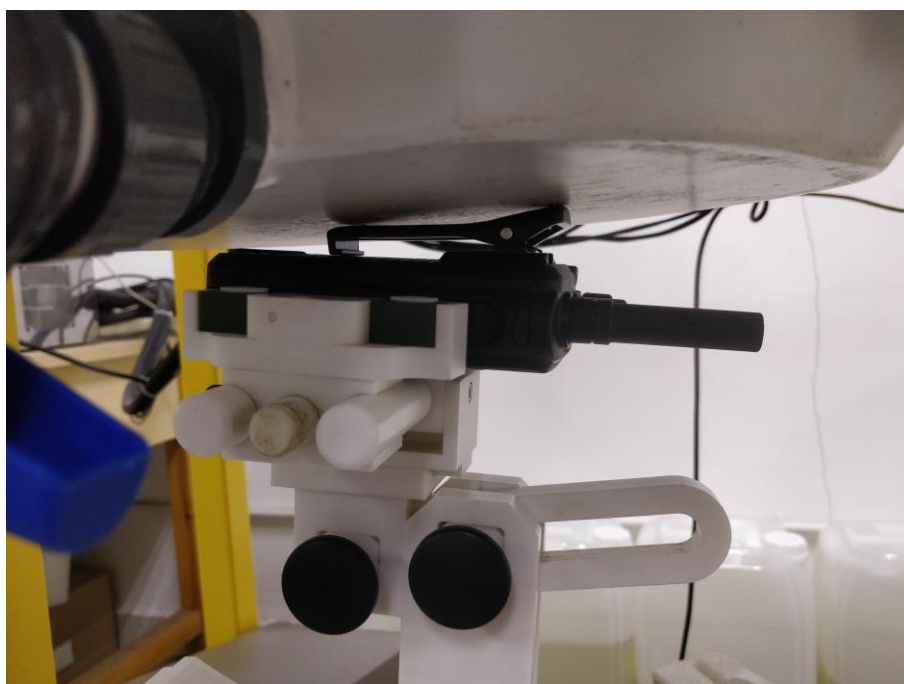

Annex E. Calibration Certificate

Please refer to the exhibit for the calibration certificate

******* END OF REPORT *******