

7.6. Time of Occupancy Measurement

7.6.1. Test Limit

The maximum permissible time of occupancy is 400ms within a period of 400ms multiplied by the number of hopping channels employed.

7.6.2. Test Procedure Used

ANSI C63.10-2013 - Section 7.8.4

7.6.3. Test Settling

1. Span = zero span, centered on a hopping channel.
2. RBW = 1MHz
3. VBW \geq RBW
4. Sweep time = as necessary to capture the entire dwell time per hopping channel
5. Detector = Peak
6. Trace mode = max hold

If possible, use the marker-delta function to determine the dwell time. If this value varies with different modes of operation (data rate, modulation format, etc.), repeat this test for each variation.

An oscilloscope may be used instead of a spectrum analyzer. The EUT shall show compliance with the appropriate regulatory limit for the number of hopping channels. A plot of the data shall be included in the test report.

7.6.4. Test Setup

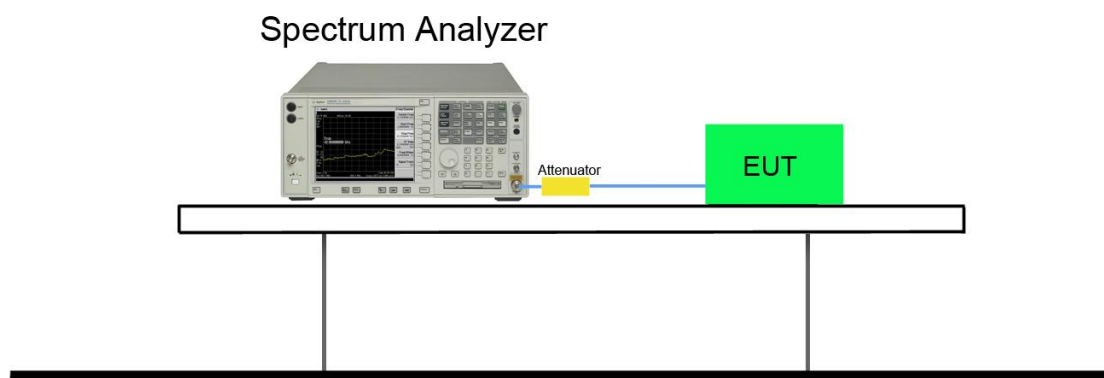

7.6.5. Test Result

Test Mode	Channel No.	Frequency (MHz)	Time of Occupancy (ms)	Limit (ms)	Result
3DH1	39	2441	118.40	< 400	Pass
3DH3	39	2441	272.16	< 400	Pass
3DH5	39	2441	321.44	< 400	Pass

3DH1 Time of Occupancy

Channel 39(2441MHz)

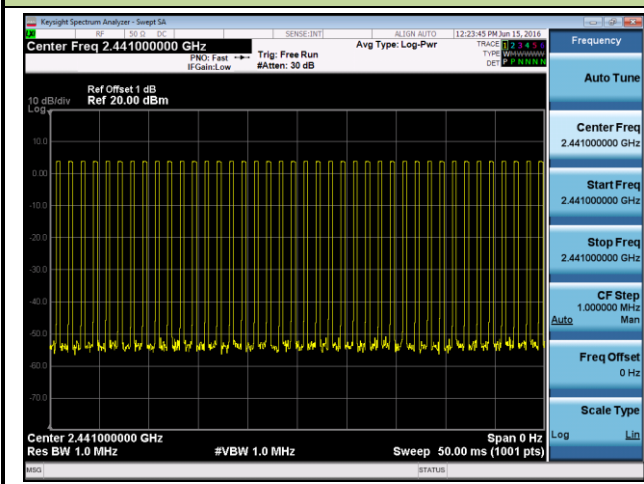

Channel 39(2441MHz)

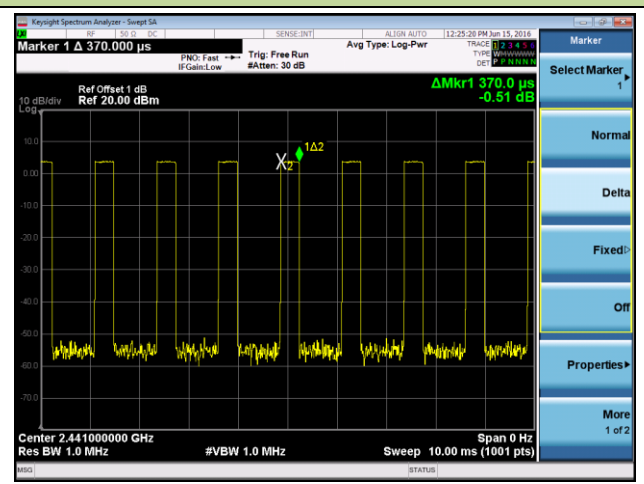

Note: Test Time Period: $0.4 \times 79 = 31.6$ sec, Hopping Times Within 1sec: $40/50$ msec = 800 hops/sec.
 The Maximum Occupancy Time within 31.6sec: $[(0.370\text{ms} \times 800)/79] \times 31.6 = 118.40$ msec.

3DH3 Time of Occupancy

Channel 39(2441MHz)

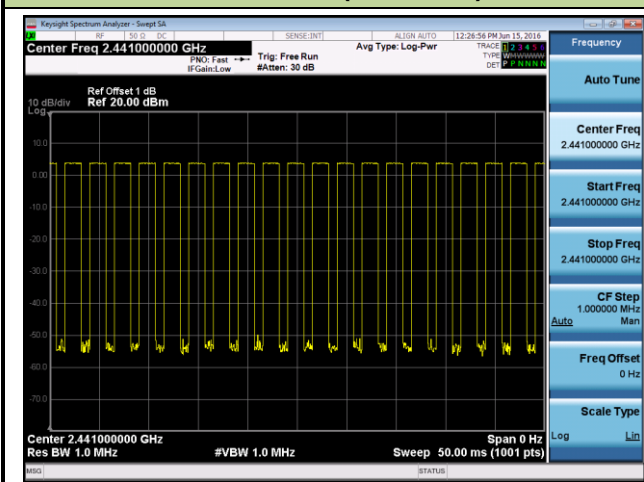

Channel 39(2441MHz)

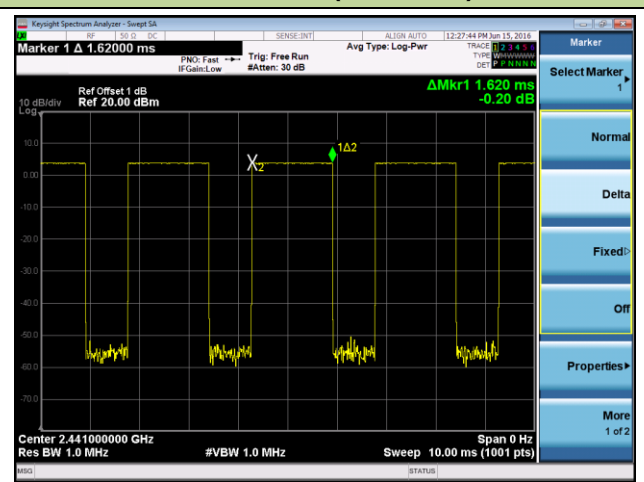

Note: Test Time Period: $0.4 \times 79 = 31.6$ sec, Hopping Times Within 1sec: $21/50$ msec = 420 hops/sec.
 The Maximum Occupancy Time within 31.6sec: $[(1.620\text{ms} \times 420)/79] \times 31.6 = 272.16$ msec.

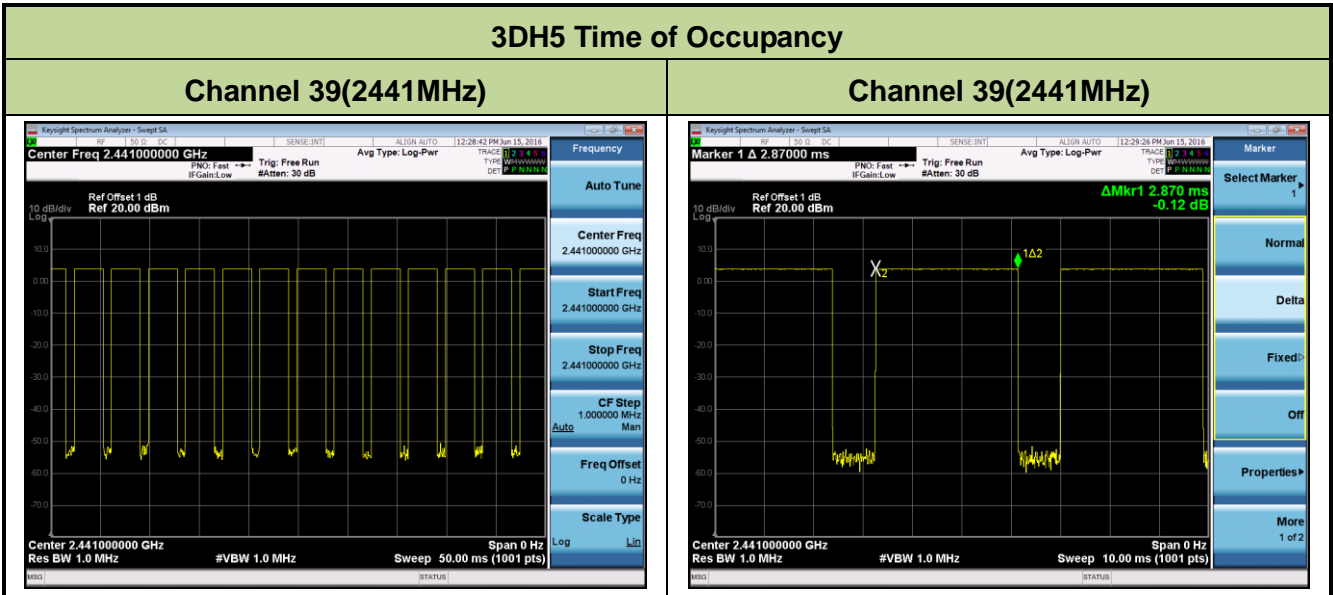

Note: Test Time Period: $0.4 * 79 = 31.6$ sec, Hopping Times Within 1 sec: $14 / 50 \text{ msec} = 280$ hops/sec.
 The Maximum Occupancy Time within 31.6 sec: $[(2.870 \text{ ms} * 280) / 79] * 31.6 = 321.44$ msec.

7.7. Band-edge Compliance Measurement

7.7.1. Test Limit

The maximum permissible emission level is 20dBc. Any emissions were lying outside of the emission bandwidth and in authorized band edges to a field strength limit specified in Section 15.209 of the Title 47 CFR.

7.7.2. Test Procedure Used

ANSI C63.10-2013 - Section 7.8.6

7.7.3. Test Setting

1. Span = wide enough to capture the peak level of the emission operating on the channel closest to the band edge, as well as any modulation products which fall outside of the authorized band of operation.
2. RBW \geq 1% of spectrum analyzer display span
3. VBW \geq RBW
4. Detector = peak
5. Sweep time = auto couple
6. Trace mode = max hold
7. Trace was allowed to stabilize

Allow the trace to stabilize. Set the marker on the emission at the band edge, or on the highest modulation product outside of the band, if this level is greater than that at the band edge. Enable the marker-delta function, then use the marker-to-peak function to move the marker to the peak of the in-band emission.

7.7.4. Test Setup

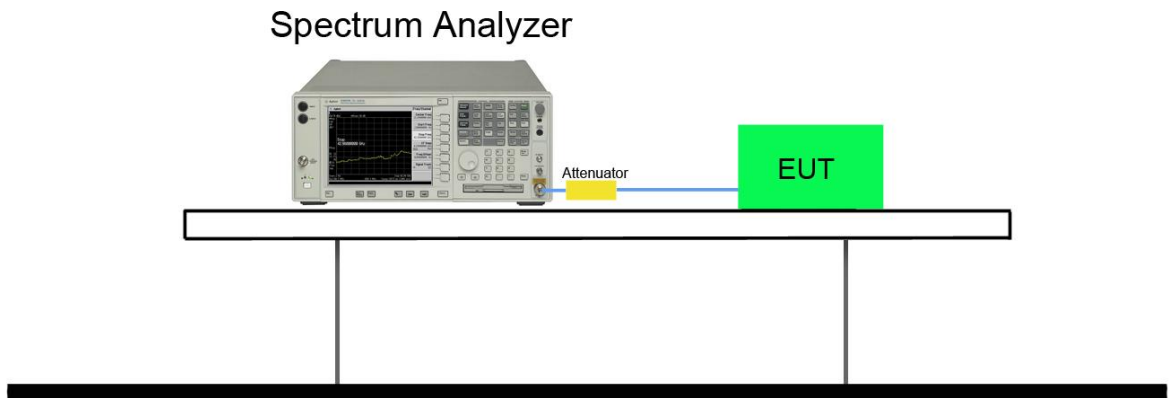

7.7.5. Test Result

Test Mode	Channel No.	Frequency (MHz)	Limit	Result
DH5	00	2402	20dBc	Pass
DH5	78	2480	20dBc	Pass
2DH5	00	2402	20dBc	Pass
2DH5	78	2480	20dBc	Pass
3DH5	00	2402	20dBc	Pass
3DH5	78	2480	20dBc	Pass

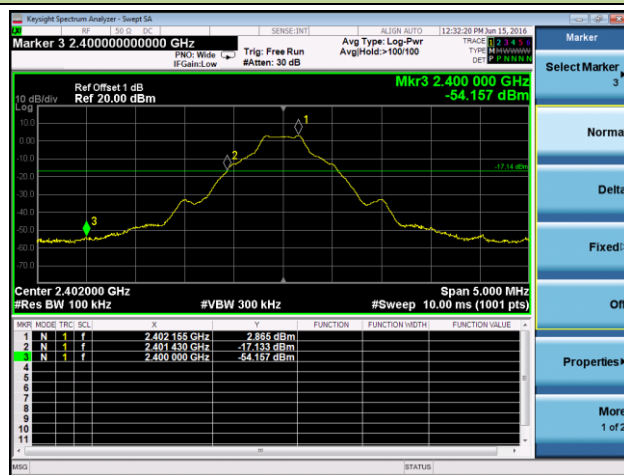
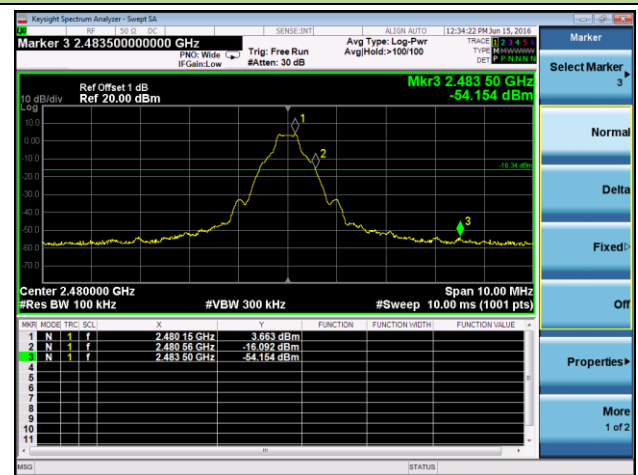
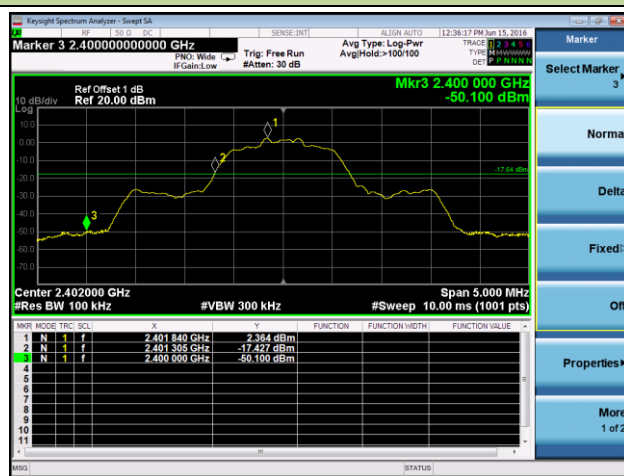
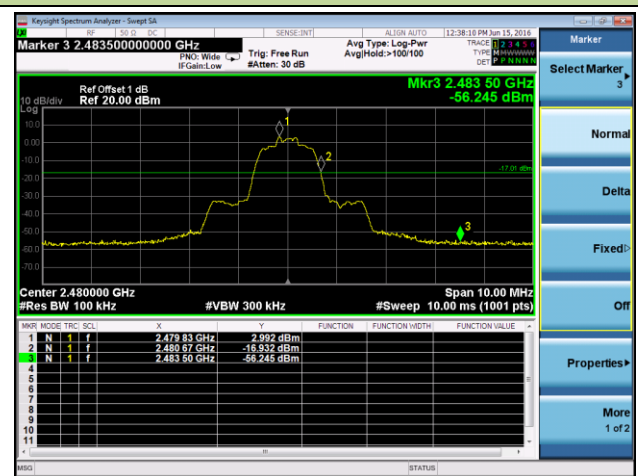
DH5 Band-edge Compliance
Channel 00 (2402MHz)

Channel 78 (2480MHz)

2DH5 Band-edge Compliance
Channel 00 (2402MHz)

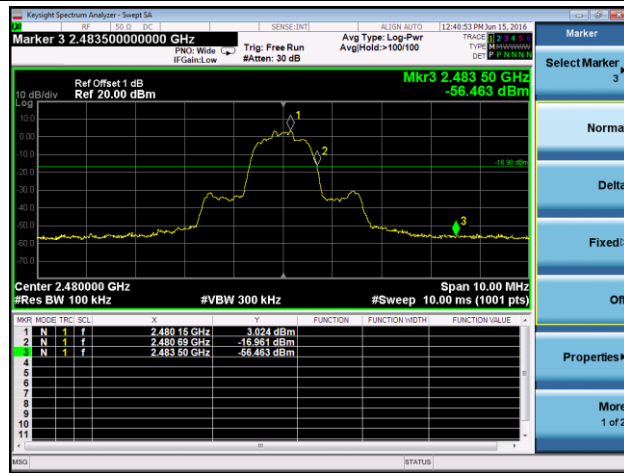
Channel 78 (2480MHz)

3DH5 Band-edge Compliance

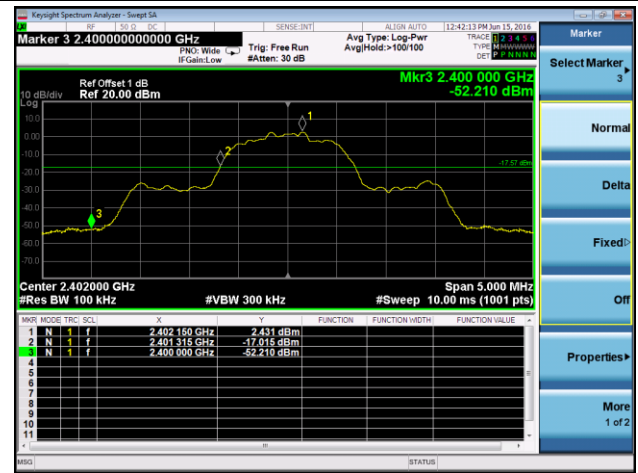
Channel 00 (2402MHz)



Channel 78 (2480MHz)



DH5 Operation Frequency Range of 20dB Bandwidth within Hopping Mode

Channel 00 (2402MHz)

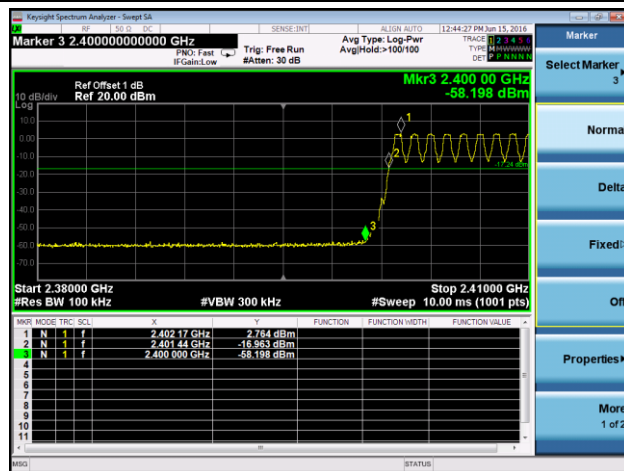

Channel 78 (2480MHz)

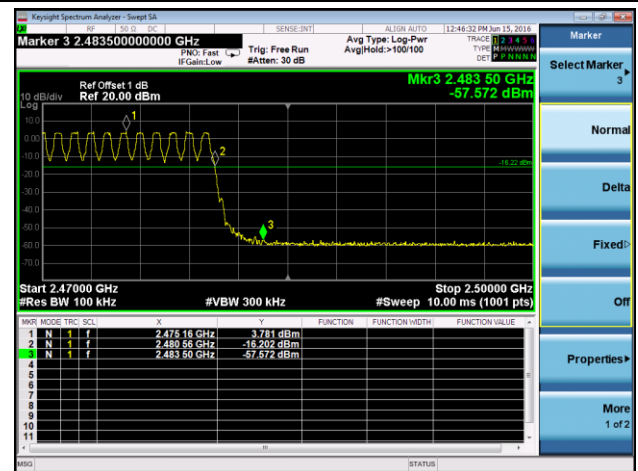

2DH5 Operation Frequency Range of 20dB Bandwidth within Hopping Mode

Channel 00 (2402MHz)

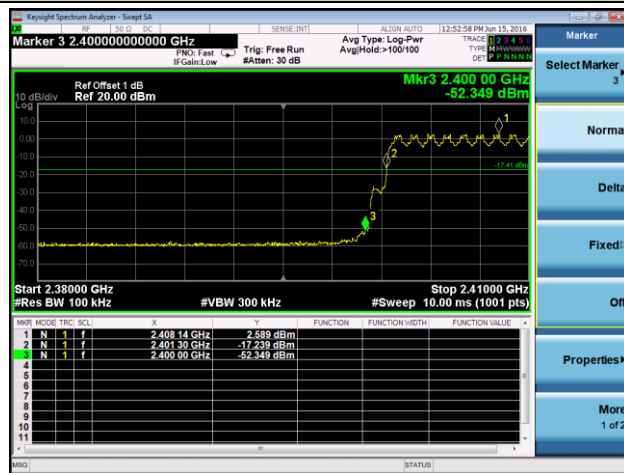

Channel 78 (2480MHz)

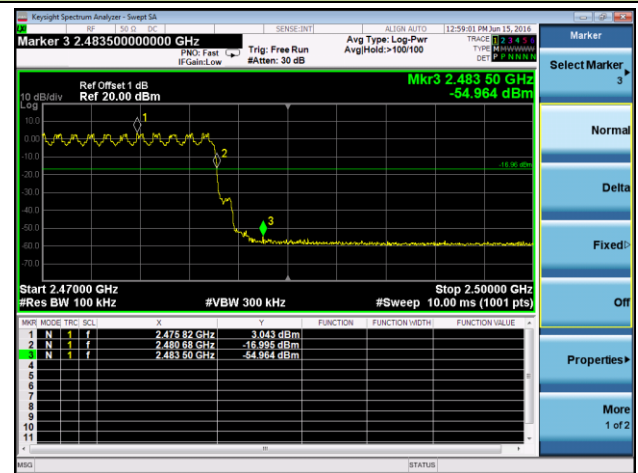

3DH5 Operation Frequency Range of 20dB Bandwidth within Hopping Mode

Channel 00 (2402MHz)

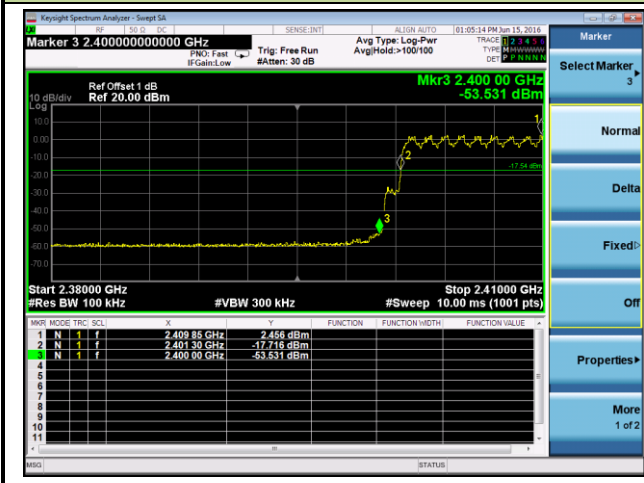

Channel 78 (2480MHz)

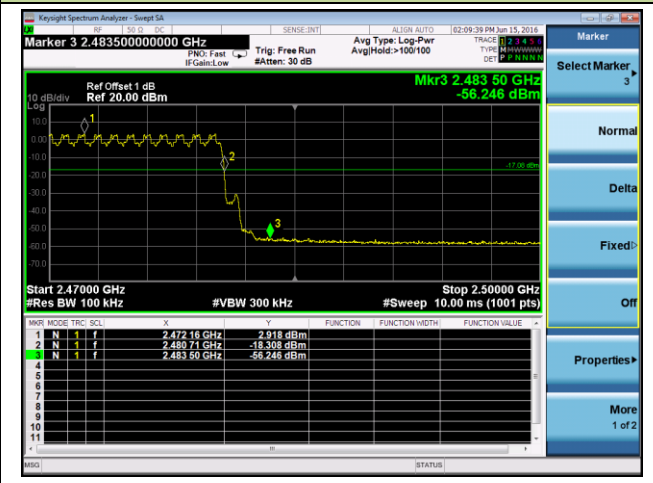

7.8. Conducted Spurious Emissions Measurement

7.8.1. Test Limit

In any 100 kHz bandwidth outside the frequency band in which the spread spectrum or digitally modulated intentional radiator is operating, the radio frequency power that is produced by the intentional radiator shall be at least 20 dB below that in the 100 kHz bandwidth within the band that contains the highest level of the desired power, based on either an RF conducted or a radiated measurement, provided the transmitter demonstrates compliance with the peak conducted or a radiated measurement, provided the transmitter demonstrates compliance with the peak conducted power limits.

7.8.2. Test Procedure Used

ANSI C63.10-2013 - Section 7.8.8

7.8.3. Test Setting

1. Span = wide enough to capture the peak level of the in-band emission and all spurious emissions (e.g., harmonics) from the lowest frequency generated in the EUT up through the 10th harmonic. Typically, several plots are required to cover this entire span.
2. RBW = 100kHz
3. VBW = 300kHz
4. Detector = peak
5. Sweep time = auto couple
6. Trace mode = max hold
7. Trace was allowed to stabilize

Set the marker on the peak of any spurious emission recorded. The level displayed must comply with the limit specified in this section.

7.8.4. Test Setup

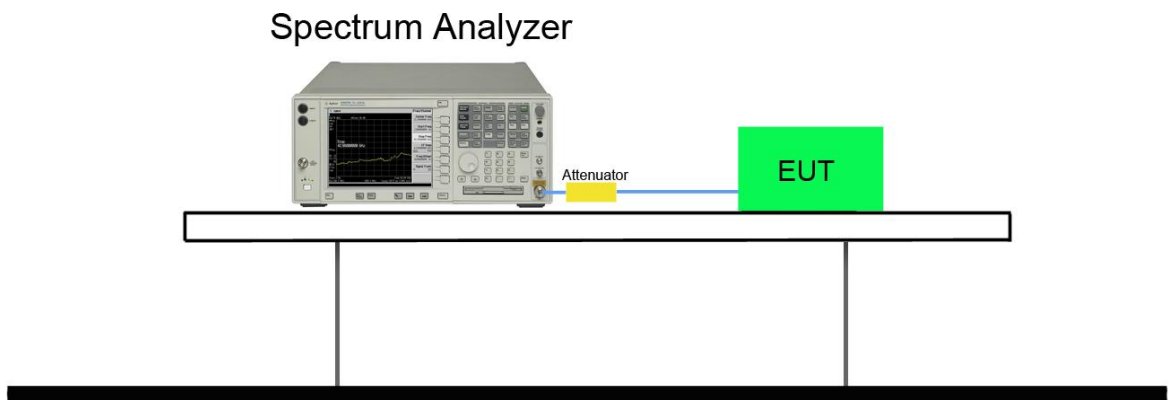

7.8.5. Test Result

Test Mode	Channel No.	Frequency (MHz)	Limit (MHz)	Result
DH5	00	2402	20dBc	Pass
DH5	39	2441	20dBc	Pass
DH5	78	2480	20dBc	Pass
2DH5	00	2402	20dBc	Pass
2DH5	39	2441	20dBc	Pass
2DH5	78	2480	20dBc	Pass
3DH5	00	2402	20dBc	Pass
3DH5	39	2441	20dBc	Pass
3DH5	78	2480	20dBc	Pass

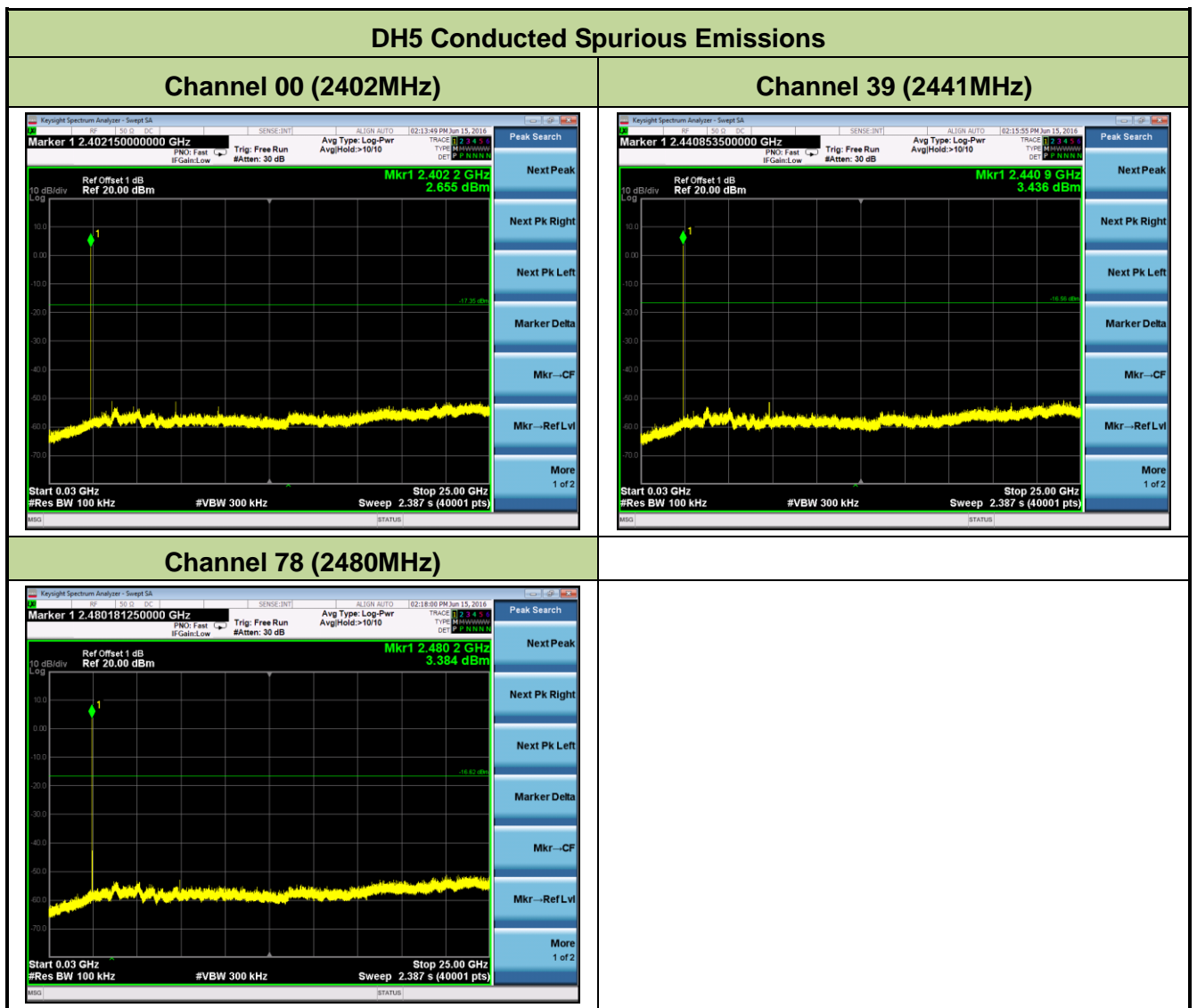

2DH5 Conducted Spurious Emissions

Channel 00 (2402MHz)

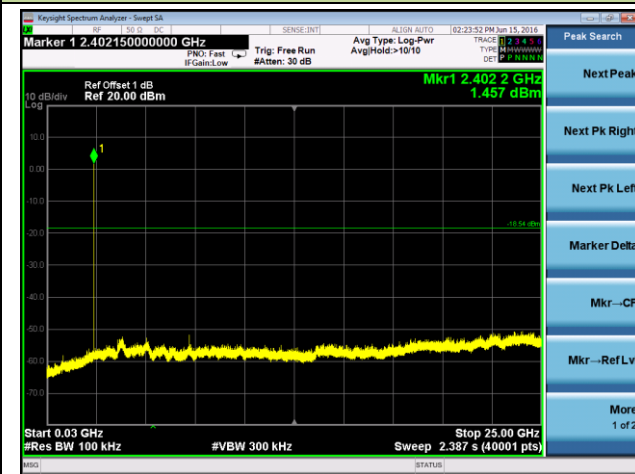

Channel 39 (2441MHz)

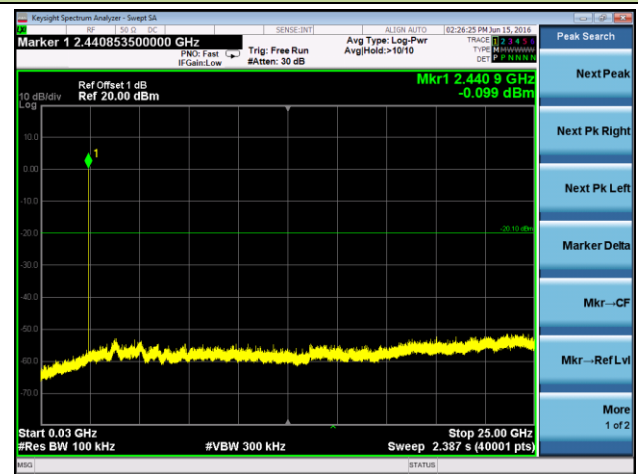

Channel 78 (2480MHz)

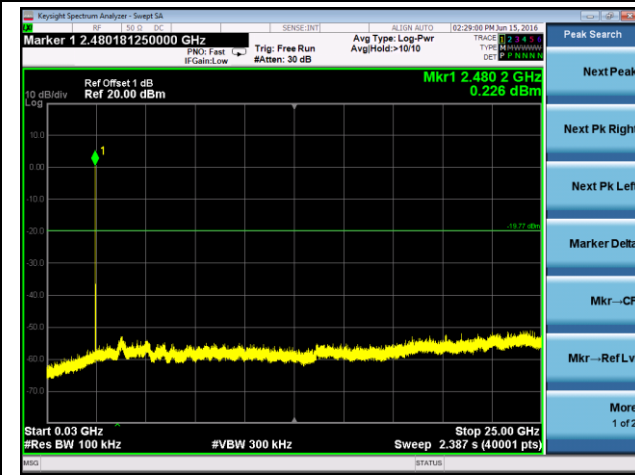

3DH5 Conducted Spurious Emissions

Channel 00 (2402MHz)

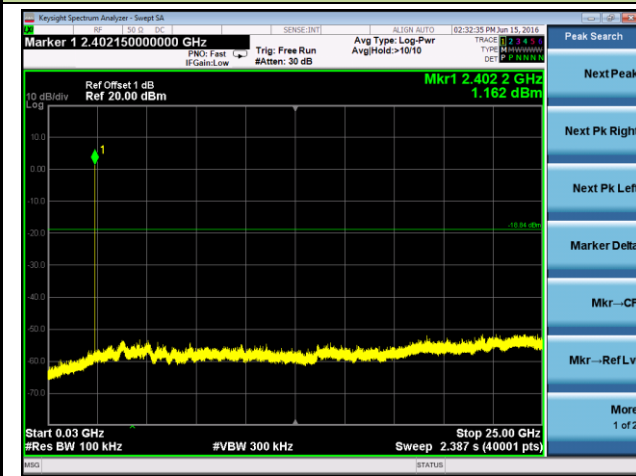

Channel 39 (2441MHz)

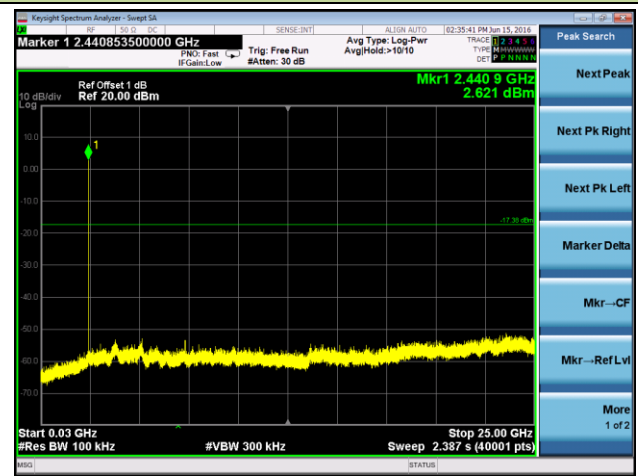

Channel 78 (2480MHz)

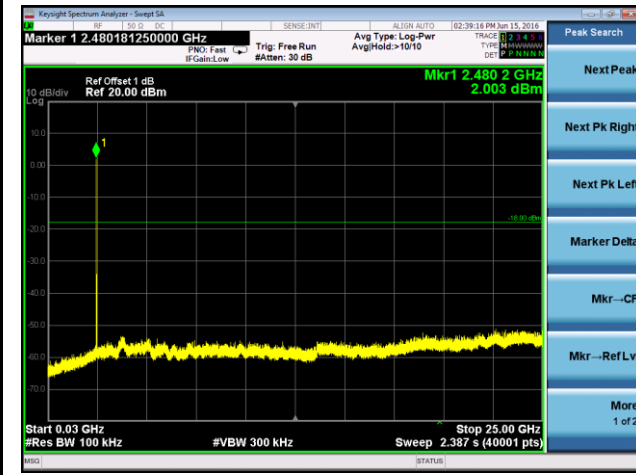

7.9. Radiated Spurious Emission Measurement

7.9.1. Test Limit

All out of band emissions appearing in a restricted band as specified in Section 15.205 of the Title 47 CFR must not exceed the limits shown in Table per Section 15.209.

FCC Part 15 Subpart C Paragraph 15.209		
Frequency [MHz]	Field Strength [V/m]	Measured Distance [Meters]
0.009 - 0.490	2400/F (kHz)	300
0.490 - 1.705	24000/F (kHz)	30
1.705 – 30	30	30
30 – 88	100	3
88 – 216	150	3
216 – 960	200	3
Above 960	500	3

7.9.2. Test Procedure Used

ANSI C63.10-2013 - Section 6.10.5

7.9.3. Test Setting

Peak Field Strength Measurements

1. Analyzer center frequency was set to the frequency of the radiated spurious emission of interest
2. RBW = as specified in Table 1
3. VBW = 3 * RBW
4. Detector = peak
5. Sweep time = auto couple
6. Trace mode = max hold
7. Trace was allowed to stabilize

Table 1 - RBW as a function of frequency

Frequency	RBW
9 ~ 150 kHz	200 ~ 300 Hz
0.15 ~ 30 MHz	9 ~ 10 kHz
30 ~ 1000 MHz	100 ~ 120 kHz
> 1000 MHz	1 MHz

Average Field Strength Measurements

1. Analyzer center frequency was set to the frequency of the radiated spurious emission of interest
2. RBW = 1MHz
3. VBW \geq 1/T
4. De As an alternative, the instrument may be set to linear detector mode. Ensure that video filtering is applied in linear voltage domain (rather than in a log or dB domain). Some instruments require linear display mode in order to accomplish this. Others have a setting for Average-VBW Type, which can be set to "Voltage" regardless of the display mode
5. Detector = Peak
6. Sweep time = auto
7. Trace mode = max hold
8. Allow max hold to run for at least 50 times (1/duty cycle) traces

7.9.4. Test Setup

9kHz ~ 30MHz Test Setup:

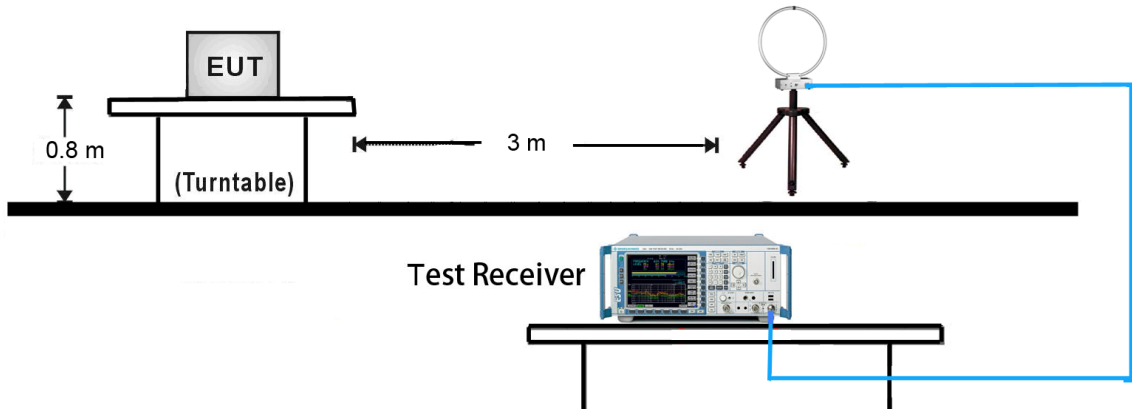

30MHz ~ 1GHz Test Setup:

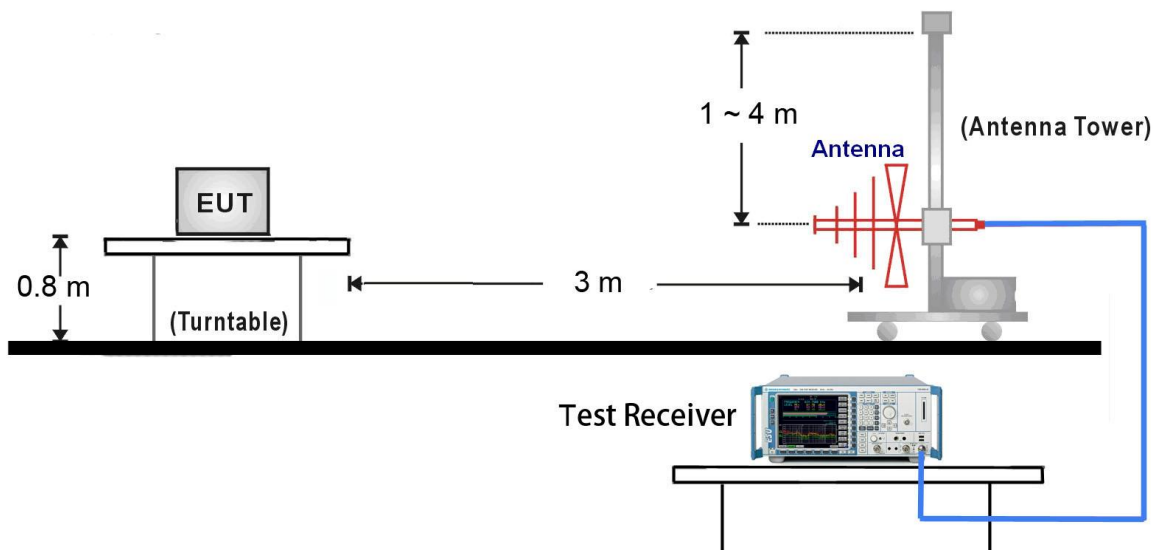

1GHz ~ 25GHz Test Setup:

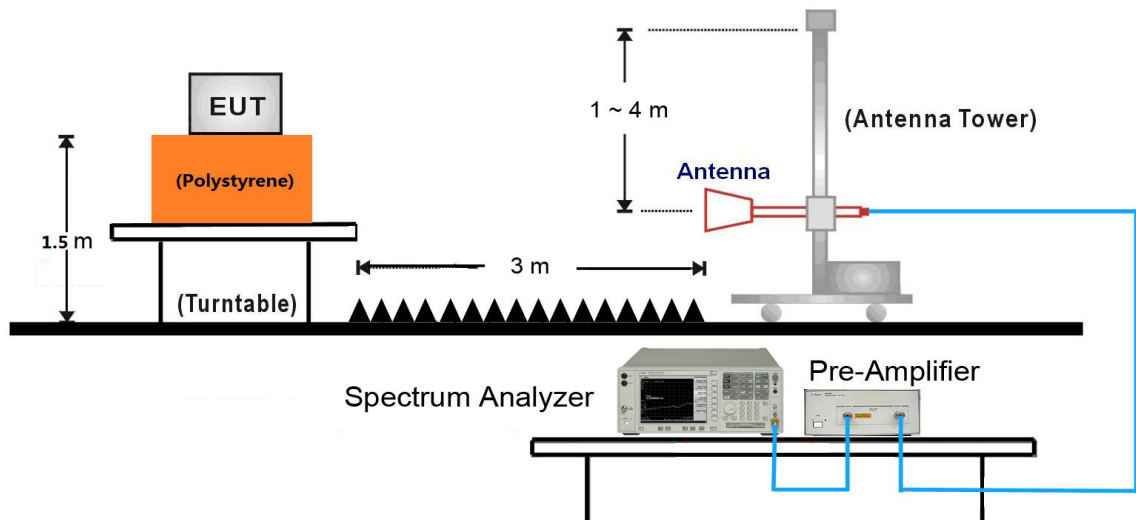

7.9.5. Test Result

Test Mode:	DH5	Test Site:	AC1
Test Channel:	00	Test Engineer:	Roy Cheng
Remark:	1. Average measurement was not performed if peak level lower than average limit. 2. Other frequency was 20dB below limit line within 1-18GHz, there is not show in the report.		

Mark	Frequency (MHz)	Reading Level (dBμV)	Factor (dB)	Measure Level (dBμV/m)	Limit (dBμV/m)	Margin (dB)	Detector	Polarization
*	8752.0	34.3	11.6	45.9	79.9	-34.0	Peak	Horizontal
*	9610.5	37.9	12.5	50.4	79.9	-29.5	Peak	Horizontal
	10885.5	33.6	16.3	49.9	74.0	-24.1	Peak	Horizontal
	12016.0	32.0	17.2	49.2	74.0	-24.8	Peak	Horizontal
*	8777.5	33.6	11.9	45.5	79.9	-34.4	Peak	Vertical
*	9610.5	39.3	12.5	51.8	79.9	-28.1	Peak	Vertical
	11047.0	32.3	16.6	48.9	74.0	-25.1	Peak	Vertical
	11752.5	32.8	16.8	49.6	74.0	-24.4	Peak	Vertical

Note 1: "*" is not in restricted band, its limit is 20dBc of the fundamental emission level (99.9dBμV/m) or 15.209 which is higher.

Note 2: Measure Level (dBμV/m) = Reading Level (dBμV) + Factor (dB)

Factor (dB) = Cable Loss (dB) + Antenna Factor (dB/m) - Pre_Amplifier Gain (dB)

Test Mode:	DH5	Test Site:	AC1
Test Channel:	39	Test Engineer:	Roy Cheng
Remark:	1. Average measurement was not performed if peak level lower than average limit. 2. Other frequency was 20dB below limit line within 1-18GHz, there is not show in the report.		

Mark	Frequency (MHz)	Reading Level (dBμV)	Factor (dB)	Measure Level (dBμV/m)	Limit (dBμV/m)	Margin (dB)	Detector	Polarization
*	7111.5	34.4	10.1	44.5	80.3	-35.8	Peak	Horizontal
*	8735.0	34.5	11.6	46.1	80.3	-34.2	Peak	Horizontal
	9117.5	33.1	12.4	45.5	74.0	-28.5	Peak	Horizontal
	11472.0	33.0	17.1	50.1	74.0	-23.9	Peak	Horizontal
*	8777.5	33.6	11.9	45.5	80.3	-34.8	Peak	Vertical
*	9763.5	37.3	12.8	50.1	80.3	-30.2	Peak	Vertical
	10877.0	31.5	16.3	47.8	74.0	-26.2	Peak	Vertical
	11455.0	33.2	17.3	50.5	74.0	-23.5	Peak	Vertical

Note 1: "*" is not in restricted band, its limit is 20dBc of the fundamental emission level (100.3dBμV/m) or 15.209 which is higher.

Note 2: Measure Level (dBμV/m) = Reading Level (dBμV) + Factor (dB)

Factor (dB) = Cable Loss (dB) + Antenna Factor (dB/m) - Pre_Amplifier Gain (dB)

Test Mode:	DH5	Test Site:	AC1
Test Channel:	78	Test Engineer:	Roy Cheng
Remark:	1. Average measurement was not performed if peak level lower than average limit. 2. Other frequency was 20dB below limit line within 1-18GHz, there is not show in the report.		

Mark	Frequency (MHz)	Reading Level (dBμV)	Factor (dB)	Measure Level (dBμV/m)	Limit (dBμV/m)	Margin (dB)	Detector	Polarization
*	7205.0	34.7	10.5	45.2	80.9	-35.7	Peak	Horizontal
*	8658.5	34.3	11.1	45.4	80.9	-35.5	Peak	Horizontal
	9330.0	33.4	12.9	46.3	74.0	-27.7	Peak	Horizontal
	11667.5	33.9	17.6	51.5	74.0	-22.5	Peak	Horizontal
*	7137.0	34.9	10.4	45.3	80.9	-35.6	Peak	Vertical
*	8752.0	33.8	11.6	45.4	80.9	-35.5	Peak	Vertical
	9389.5	33.3	12.4	45.7	74.0	-28.3	Peak	Vertical
	11463.5	33.2	17.2	50.4	74.0	-23.6	Peak	Vertical

Note 1: "*" is not in restricted band, its limit is 20dBc of the fundamental emission level (100.9dBμV/m) or 15.209 which is higher.

Note 2: Measure Level (dBμV/m) = Reading Level (dBμV) + Factor (dB)

Factor (dB) = Cable Loss (dB) + Antenna Factor (dB/m) - Pre_Amplifier Gain (dB)

Test Mode:	2DH5	Test Site:	AC1
Test Channel:	00	Test Engineer:	Roy Cheng
Remark:	1. Average measurement was not performed if peak level lower than average limit. 2. Other frequency was 20dB below limit line within 1-18GHz, there is not show in the report.		

Mark	Frequency (MHz)	Reading Level (dBμV)	Factor (dB)	Measure Level (dBμV/m)	Limit (dBμV/m)	Margin (dB)	Detector	Polarization
*	8769.0	33.7	11.8	45.5	79.3	-33.8	Peak	Horizontal
*	9610.5	37.2	12.5	49.7	79.3	-29.6	Peak	Horizontal
	11013.0	32.0	16.3	48.3	74.0	-25.7	Peak	Horizontal
	11633.5	32.5	17.4	49.9	74.0	-24.1	Peak	Horizontal
*	8760.5	34.6	11.6	46.2	79.3	-33.1	Peak	Vertical
*	9610.5	38.0	12.5	50.5	79.3	-28.8	Peak	Vertical
	10783.5	31.9	16.0	47.9	74.0	-26.1	Peak	Vertical
	11659.0	33.4	17.5	50.9	74.0	-23.1	Peak	Vertical

Note 1: "*" is not in restricted band, its limit is 20dBc of the fundamental emission level (99.3dBμV/m) or 15.209 which is higher.

Note 2: Measure Level (dBμV/m) = Reading Level (dBμV) + Factor (dB)

Factor (dB) = Cable Loss (dB) + Antenna Factor (dB/m) - Pre_Amplifier Gain (dB)

Test Mode:	2DH5	Test Site:	AC1
Test Channel:	39	Test Engineer:	Roy Cheng
Remark:	1. Average measurement was not performed if peak level lower than average limit. 2. Other frequency was 20dB below limit line within 1-18GHz, there is not show in the report.		

Mark	Frequency (MHz)	Reading Level (dB μ V)	Factor (dB)	Measure Level (dB μ V/m)	Limit (dB μ V/m)	Margin (dB)	Detector	Polarization
*	7111.5	35.3	10.1	45.4	79.7	-34.3	Peak	Horizontal
*	8828.5	34.6	11.6	46.2	79.7	-33.5	Peak	Horizontal
	9372.5	34.4	12.7	47.1	74.0	-26.9	Peak	Horizontal
	11455.0	33.3	17.3	50.6	74.0	-23.4	Peak	Horizontal
*	7103.0	34.8	10.1	44.9	79.7	-34.8	Peak	Vertical
*	8667.0	34.4	11.3	45.7	79.7	-34.0	Peak	Vertical
	9449.0	34.4	12.4	46.8	74.0	-27.2	Peak	Vertical
	11353.0	33.9	17.2	51.1	74.0	-22.9	Peak	Vertical

Note 1: "*" is not in restricted band, its limit is 20dBc of the fundamental emission level (99.7dB μ V/m) or 15.209 which is higher.

Note 2: Measure Level (dB μ V/m) = Reading Level (dB μ V) + Factor (dB)

Factor (dB) = Cable Loss (dB) + Antenna Factor (dB/m) - Pre_Amplifier Gain (dB)

Test Mode:	2DH5	Test Site:	AC1
Test Channel:	78	Test Engineer:	Roy Cheng
Remark:	1. Average measurement was not performed if peak level lower than average limit. 2. Other frequency was 20dB below limit line within 1-18GHz, there is not show in the report.		

Mark	Frequency (MHz)	Reading Level (dB μ V)	Factor (dB)	Measure Level (dB μ V/m)	Limit (dB μ V/m)	Margin (dB)	Detector	Polarization
*	7069.0	34.0	9.9	43.9	80.3	-36.4	Peak	Horizontal
*	8760.5	34.3	11.6	45.9	80.3	-34.4	Peak	Horizontal
	9304.5	32.8	12.7	45.5	74.0	-28.5	Peak	Horizontal
	11268.0	32.9	17.0	49.9	74.0	-24.1	Peak	Horizontal
*	7171.0	35.2	10.5	45.7	80.3	-34.6	Peak	Vertical
*	8650.0	34.2	11.0	45.2	80.3	-35.1	Peak	Vertical
	9355.5	33.6	12.7	46.3	74.0	-27.7	Peak	Vertical
	11718.5	33.6	17.3	50.9	74.0	-23.1	Peak	Vertical

Note 1: "*" is not in restricted band, its limit is 20dBc of the fundamental emission level (100.3dB μ V/m) or 15.209 which is higher.

Note 2: Measure Level (dB μ V/m) = Reading Level (dB μ V) + Factor (dB)

Factor (dB) = Cable Loss (dB) + Antenna Factor (dB/m) - Pre_Amplifier Gain (dB)

Test Mode:	3DH5	Test Site:	AC1
Test Channel:	00	Test Engineer:	Roy Cheng
Remark:	1. Average measurement was not performed if peak level lower than average limit. 2. Other frequency was 20dB below limit line within 1-18GHz, there is not show in the report.		

Mark	Frequency (MHz)	Reading Level (dBμV)	Factor (dB)	Measure Level (dBμV/m)	Limit (dBμV/m)	Margin (dB)	Detector	Polarization
*	8794.5	34.5	11.8	46.3	79.6	-33.3	Peak	Horizontal
*	9610.5	36.0	12.5	48.5	79.6	-31.1	Peak	Horizontal
	10732.5	32.0	15.9	47.9	74.0	-26.1	Peak	Horizontal
	11667.5	32.9	17.6	50.5	74.0	-23.5	Peak	Horizontal
*	8760.5	33.9	11.6	45.5	79.6	-34.1	Peak	Vertical
*	9610.5	40.2	12.5	52.7	79.6	-26.9	Peak	Vertical
	10817.5	32.0	16.1	48.1	74.0	-25.9	Peak	Vertical
	11446.5	32.7	17.1	49.8	74.0	-24.2	Peak	Vertical

Note 1: "*" is not in restricted band, its limit is 20dBc of the fundamental emission level (99.6dBμV/m) or 15.209 which is higher.

Note 2: Measure Level (dBμV/m) = Reading Level (dBμV) + Factor (dB)

Factor (dB) = Cable Loss (dB) + Antenna Factor (dB/m) - Pre_Amplifier Gain (dB)

Test Mode:	3DH5	Test Site:	AC1
Test Channel:	39	Test Engineer:	Roy Cheng
Remark:	1. Average measurement was not performed if peak level lower than average limit. 2. Other frequency was 20dB below limit line within 1-18GHz, there is not show in the report.		

Mark	Frequency (MHz)	Reading Level (dB μ V)	Factor (dB)	Measure Level (dB μ V/m)	Limit (dB μ V/m)	Margin (dB)	Detector	Polarization
*	8760.5	33.9	11.6	45.5	79.8	-34.3	Peak	Horizontal
*	9763.5	35.8	12.8	48.6	79.8	-31.2	Peak	Horizontal
	10630.5	34.0	15.5	49.5	74.0	-24.5	Peak	Horizontal
	11531.5	33.0	17.2	50.2	74.0	-23.8	Peak	Horizontal
*	8760.5	33.6	11.6	45.2	79.8	-34.6	Peak	Vertical
*	9763.5	35.6	12.8	48.4	79.8	-31.4	Peak	Vertical
	10698.5	33.3	15.6	48.9	74.0	-25.1	Peak	Vertical
	11727.0	33.3	17.2	50.5	74.0	-23.5	Peak	Vertical

Note 1: "*" is not in restricted band, its limit is 20dBc of the fundamental emission level (99.8dB μ V/m) or 15.209 which is higher.

Note 2: Measure Level (dB μ V/m) = Reading Level (dB μ V) + Factor (dB)

Factor (dB) = Cable Loss (dB) + Antenna Factor (dB/m) - Pre_Amplifier Gain (dB)

Test Mode:	3DH5	Test Site:	AC1
Test Channel:	78	Test Engineer:	Roy Cheng
Remark:	1. Average measurement was not performed if peak level lower than average limit. 2. Other frequency was 20dB below limit line within 1-18GHz, there is not show in the report.		

Mark	Frequency (MHz)	Reading Level (dBμV)	Factor (dB)	Measure Level (dBμV/m)	Limit (dBμV/m)	Margin (dB)	Detector	Polarization
*	7111.5	34.0	10.1	44.1	80.3	-36.2	Peak	Horizontal
*	8854.0	32.9	11.7	44.6	80.3	-35.7	Peak	Horizontal
	9381.0	32.6	12.5	45.1	74.0	-28.9	Peak	Horizontal
	11718.5	32.9	17.3	50.2	74.0	-23.8	Peak	Horizontal
*	7120.0	34.5	10.1	44.6	80.3	-35.7	Peak	Vertical
*	8641.5	34.5	11.1	45.6	80.3	-34.7	Peak	Vertical
	9423.5	33.0	12.4	45.4	74.0	-28.6	Peak	Vertical
	11455.0	34.2	17.3	51.5	74.0	-22.5	Peak	Vertical

Note 1: "*" is not in restricted band, its limit is 20dBc of the fundamental emission level (100.3dBμV/m) or 15.209 which is higher.

Note 2: Measure Level (dBμV/m) = Reading Level (dBμV) + Factor (dB)

Factor (dB) = Cable Loss (dB) + Antenna Factor (dB/m) - Pre_Amplifier Gain (dB)

The worst case of Radiated Emission 9KHz ~ 1GHz and 18GHz ~ 25GHz:

Site: AC2	Time: 2016/06/17 - 09:49
Limit: FCC_Part15.209_RE(3m)	Engineer: Roy Cheng
Probe: VULB9162_0.03-8GHz	Polarity: Horizontal
EUT: Smart Phone	Power: AC 120V/60Hz
Worse Case Mode: Transmit by DH5 at Channel 2402MHz	

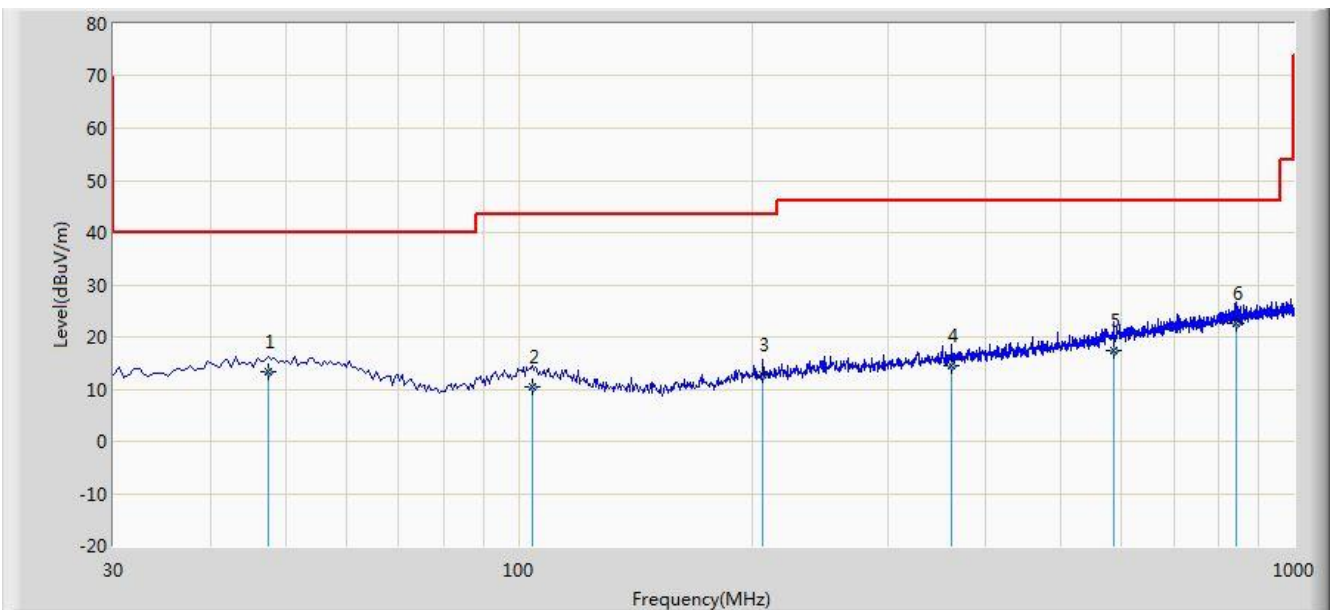

No	Flag	Mark	Frequency (MHz)	Measure Level (dBuV/m)	Reading Level (dBuV)	Over Limit (dB)	Limit (dBuV/m)	Factor (dB)	Type
1			47.460	13.350	-1.620	-26.650	40.000	14.969	QP
2			104.205	10.508	-2.620	-32.992	43.500	13.128	QP
3			206.540	12.750	0.360	-30.750	43.500	12.391	QP
4			362.225	14.426	-1.620	-31.574	46.000	16.046	QP
5			585.325	17.250	-2.610	-28.750	46.000	19.861	QP
6		*	843.345	22.479	-1.060	-23.521	46.000	23.539	QP

Note: Measure Level (dB μ V/m) = Reading Level (dB μ V) + Factor (dB)

Factor (dB) = Cable Loss (dB) + Antenna Factor (dB/m)

Site: AC1	Time: 2016/06/17 - 09:49
Limit: FCC_Part15.209_RE(3m)	Engineer: Roy Cheng
Probe: VULB9162_0.03-8GHz	Polarity: Vertical
EUT: Smart Phone	Power: AC 120V/60Hz
Worse Case Mode: Transmit by DH5 at Channel 2402MHz	

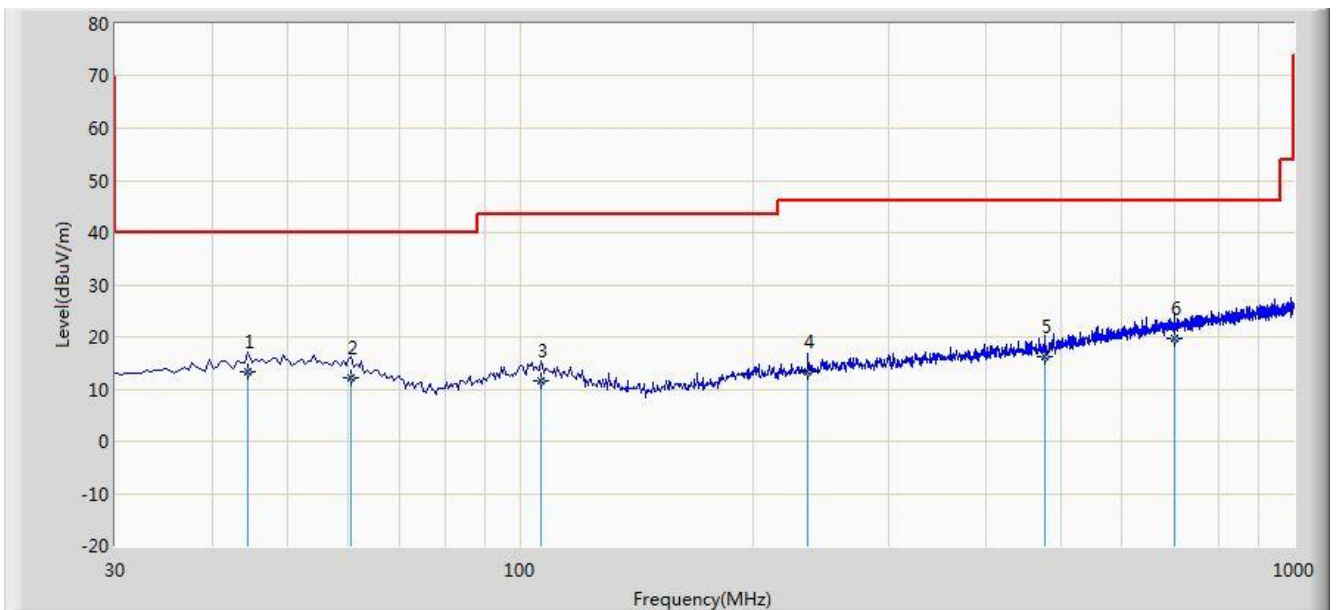

No	Flag	Mark	Frequency (MHz)	Measure Level (dBuV/m)	Reading Level (dBuV)	Over Limit (dB)	Limit (dBuV/m)	Factor (dB)	Type
1			44.550	13.396	-1.360	-26.604	40.000	14.756	QP
2			60.555	12.271	-1.520	-27.729	40.000	13.791	QP
3			106.630	11.697	-1.360	-31.803	43.500	13.057	QP
4			235.640	13.309	0.030	-32.691	46.000	13.279	QP
5			477.170	16.324	-1.630	-29.676	46.000	17.954	QP
6		*	701.725	19.582	-2.030	-26.418	46.000	21.612	QP

Note: Measure Level (dB μ V/m) = Reading Level (dB μ V) + Factor (dB)

Factor (dB) = Cable Loss (dB) + Antenna Factor (dB/m)

Site: AC2	Time: 2016/06/15 - 15:32
Limit: FCC_Part15.209_RE(3m)	Engineer: Roy Cheng
Probe: FMZB1519_0.009-30MHz	Polarity: Face On
EUT: Smart Phone	Power: AC 120V/60Hz
Note: There is the ambient noise within frequency range 9kHz~30MHz.	

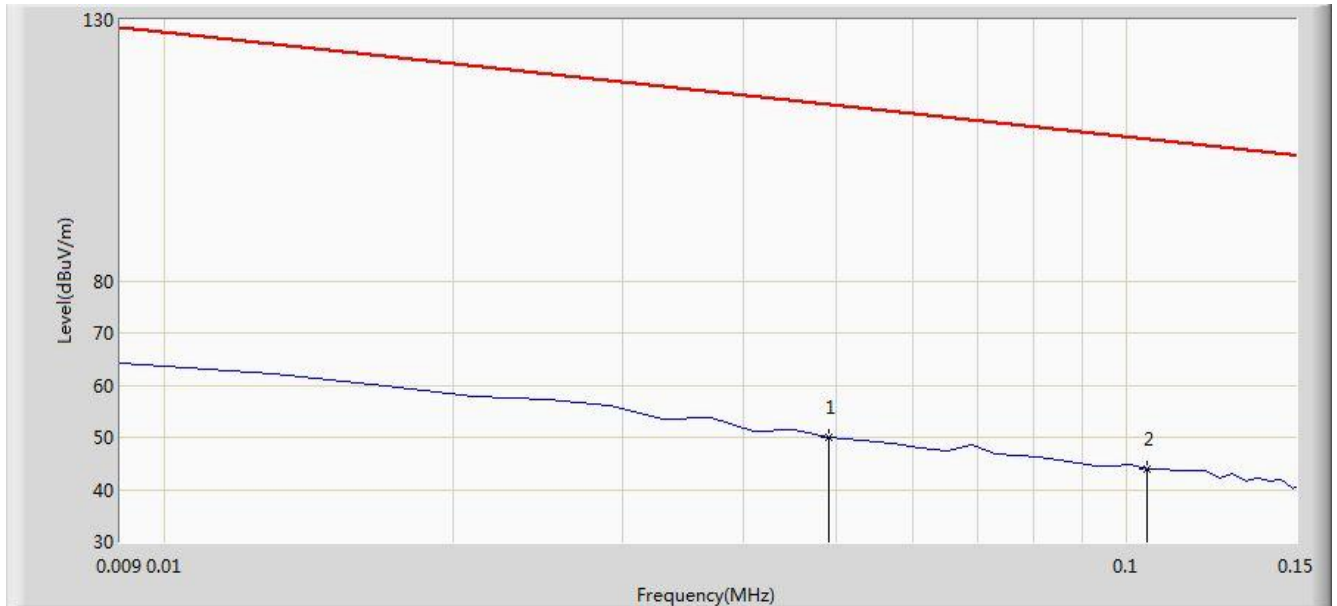

No	Flag	Mark	Frequency (MHz)	Measure Level (dBuV/m)	Reading Level (dBuV)	Over Limit (dB)	Limit (dBuV/m)	Factor (dB)	Type
1			0.049	50.112	29.552	-63.677	113.789	20.560	QP
2		*	0.105	44.043	23.845	-63.130	107.173	20.198	QP

Note: Measure Level (dB μ V/m) = Reading Level (dB μ V) + Factor (dB)

Factor (dB) = Cable Loss (dB) + Antenna Factor (dB/m)

Site: AC2	Time: 2016/06/15 - 15:41
Limit: FCC_Part15.209_RE(3m)	Engineer: Roy Cheng
Probe: FMZB1519_0.009-30MHz	Polarity: Face On
EUT: Smart Phone	Power: AC 120V/60Hz
Note: There is the ambient noise within frequency range 9kHz~30MHz.	

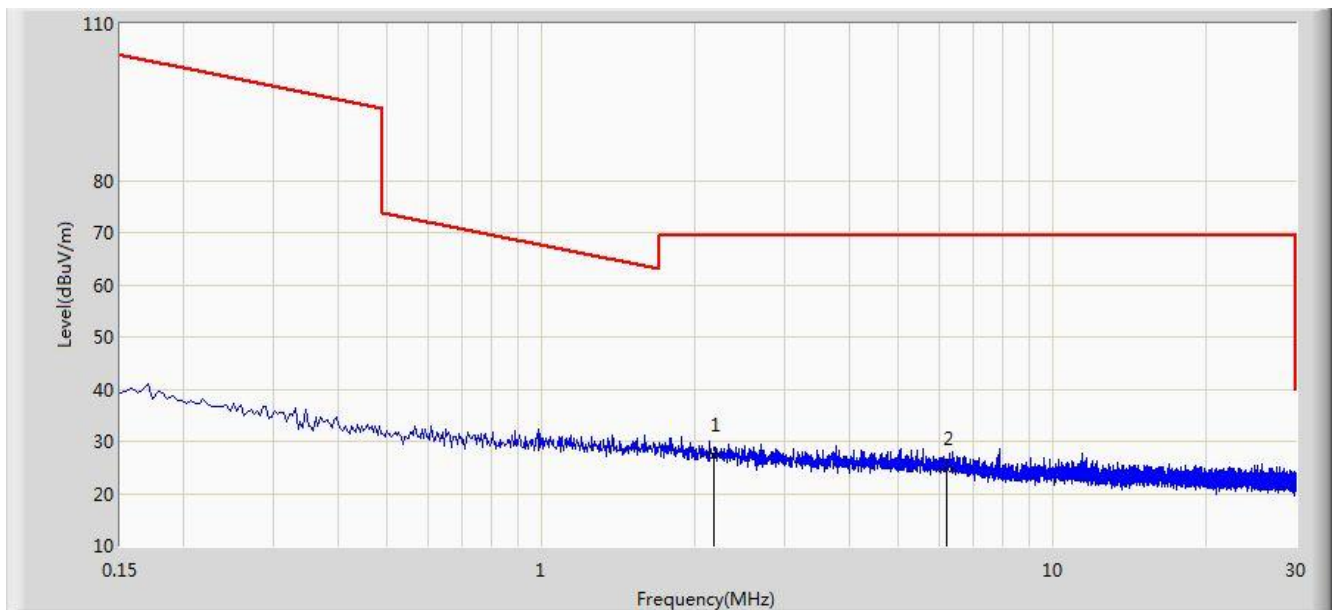

No	Flag	Mark	Frequency (MHz)	Measure Level (dBuV/m)	Reading Level (dBuV)	Over Limit (dB)	Limit (dBuV/m)	Factor (dB)	Type
1		*	2.175	27.371	6.960	-42.129	69.500	20.412	QP
2			6.216	24.786	4.701	-44.714	69.500	20.085	QP

Note: Measure Level (dB μ V/m) = Reading Level (dB μ V) + Factor (dB)

Factor (dB) = Cable Loss (dB) + Antenna Factor (dB/m)

Site: AC2	Time: 2016/06/15 - 10:21
Limit: FCC_Part15.209_RE(1m)	Engineer: Roy Cheng
Probe: BBHA9170_18-40GHz	Polarity: Horizontal
EUT: Smart Phone	Power: AC 120V/60Hz
Note: There is the ambient noise within frequency range 18GHz~25GHz.	

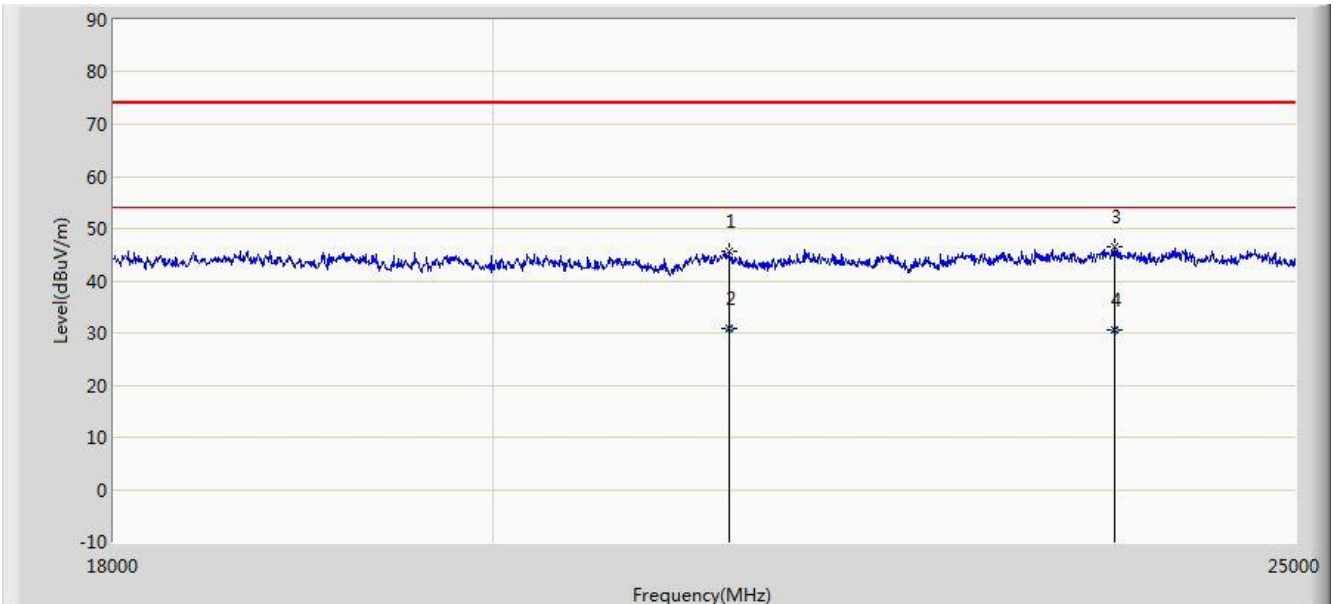

No	Flag	Mark	Frequency (MHz)	Measure Level (dBuV/m)	Reading Level (dBuV)	Over Limit (dB)	Limit (dBuV/m)	Factor (dB)	Type
1			21366.000	45.581	45.650	-28.419	74.000	-0.070	PK
2		*	21366.000	30.913	30.982	-23.087	54.000	-0.070	AV
3			23775.750	46.454	44.540	-27.546	74.000	1.914	PK
4			23775.750	30.481	28.567	-23.519	54.000	1.914	AV

Note: Measure Level (dB μ V/m) = Reading Level (dB μ V) + Factor (dB)

Factor (dB) = Cable Loss (dB) + Antenna Factor (dB/m) - Pre_Amplifier Gain (dB)

Site: AC2	Time: 2016/06/15 - 10:21
Limit: FCC_Part15.209_RE(1m)	Engineer: Roy Cheng
Probe: BBHA9170_18-40GHz	Polarity: Vertical
EUT: Smart Phone	Power: AC 120V/60Hz
Note: There is the ambient noise within frequency range 18GHz~25GHz.	

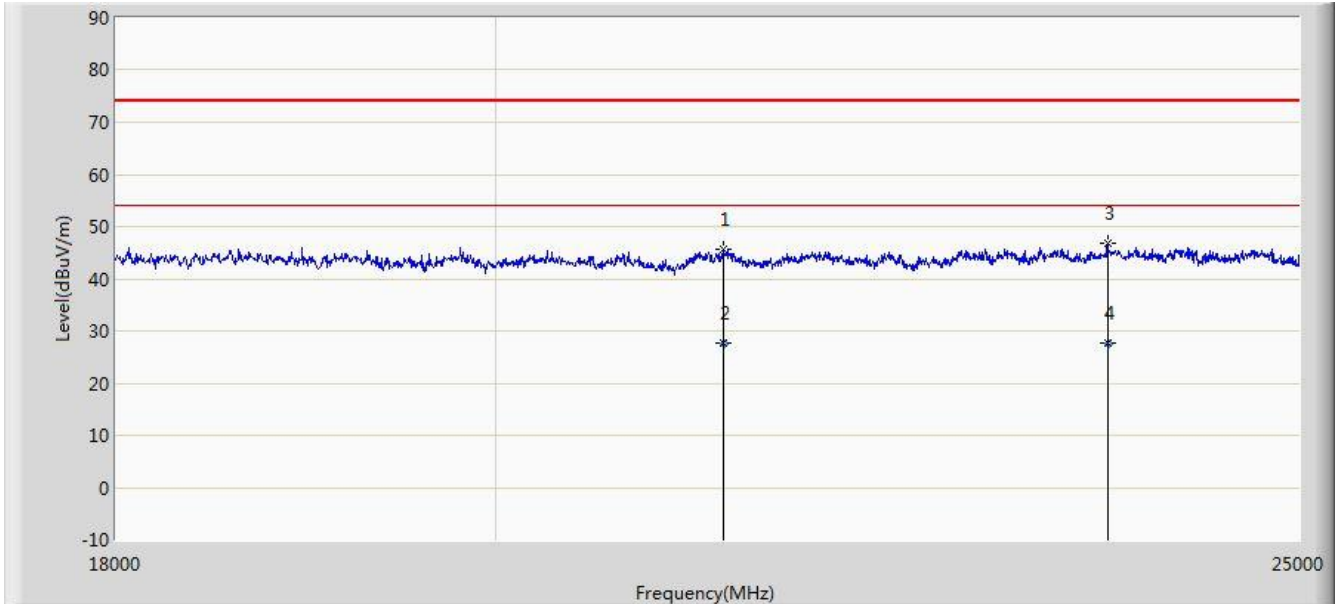

No	Flag	Mark	Frequency (MHz)	Measure Level (dBuV/m)	Reading Level (dBuV)	Over Limit (dB)	Limit (dBuV/m)	Factor (dB)	Type
1			21310.750	45.737	41.998	-28.263	74.000	-0.078	PK
2		*	21310.750	27.813	27.890	-26.187	54.000	-0.078	AV
3			23707.750	46.775	40.888	-27.225	74.000	1.824	PK
4			23707.750	27.661	25.837	-26.339	54.000	1.824	AV

Note: Measure Level (dB μ V/m) = Reading Level (dB μ V) + Factor (dB)

Factor (dB) = Cable Loss (dB) + Antenna Factor (dB/m) - Pre_Amplifier Gain (dB)

7.10. Radiated Restricted Band Edge Measurement

7.10.1. Test Result

Site: AC2	Time: 2016/06/14 - 10:56
Limit: FCC_Part15.209_RE(3m)	Engineer: Roy Cheng
Probe: BBHA9120D_1-18GHz	Polarity: Horizontal
EUT: Smart Phone	Power: AC 120V/60Hz
Test Mode: Transmit at channel 2402MHz by DH5	

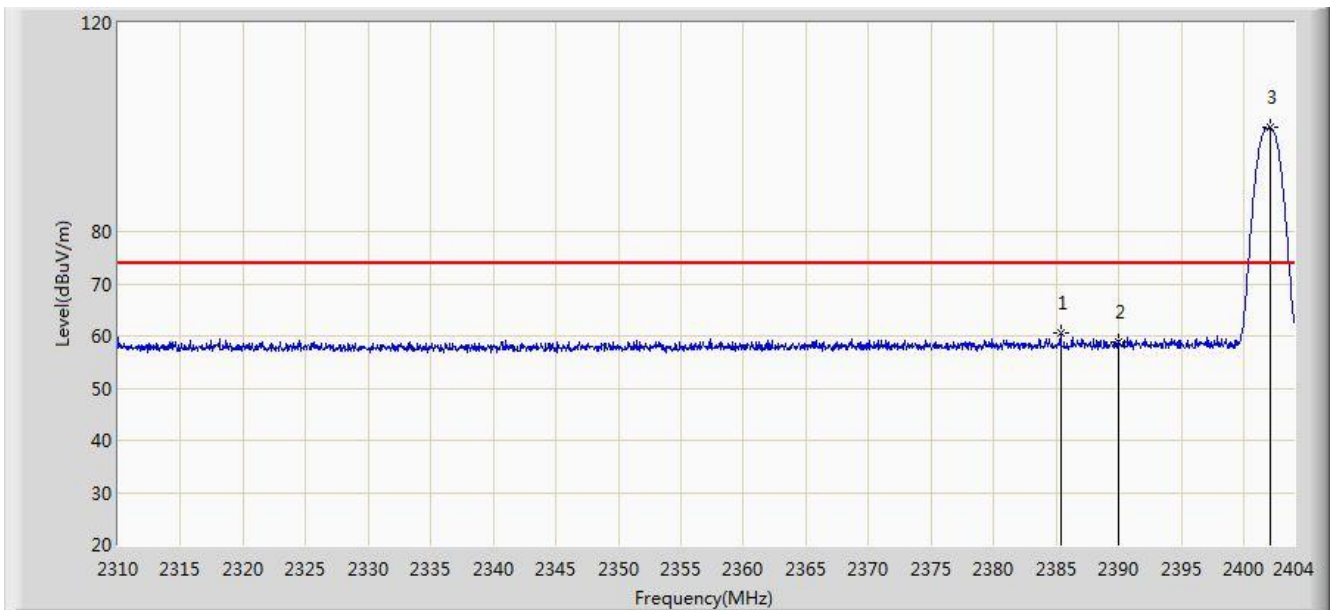

No	Flag	Mark	Frequency (MHz)	Measure Level (dBuV/m)	Reading Level (dBuV)	Over Limit (dB)	Limit (dBuV/m)	Factor (dB)	Type
1			2385.341	60.463	28.211	-13.537	74.000	32.252	PK
2			2390.000	58.893	26.615	-15.107	74.000	32.278	PK
3		*	2402.073	99.858	67.584	N/A	N/A	32.273	PK

Site: AC2	Time: 2016/06/14 - 10:59
Limit: FCC_Part15.209_RE(3m)	Engineer: Roy Cheng
Probe: BBHA9120D_1-18GHz	Polarity: Horizontal
EUT: Smart Phone	Power: AC 120V/60Hz
Test Mode: Transmit at channel 2402MHz by DH5	

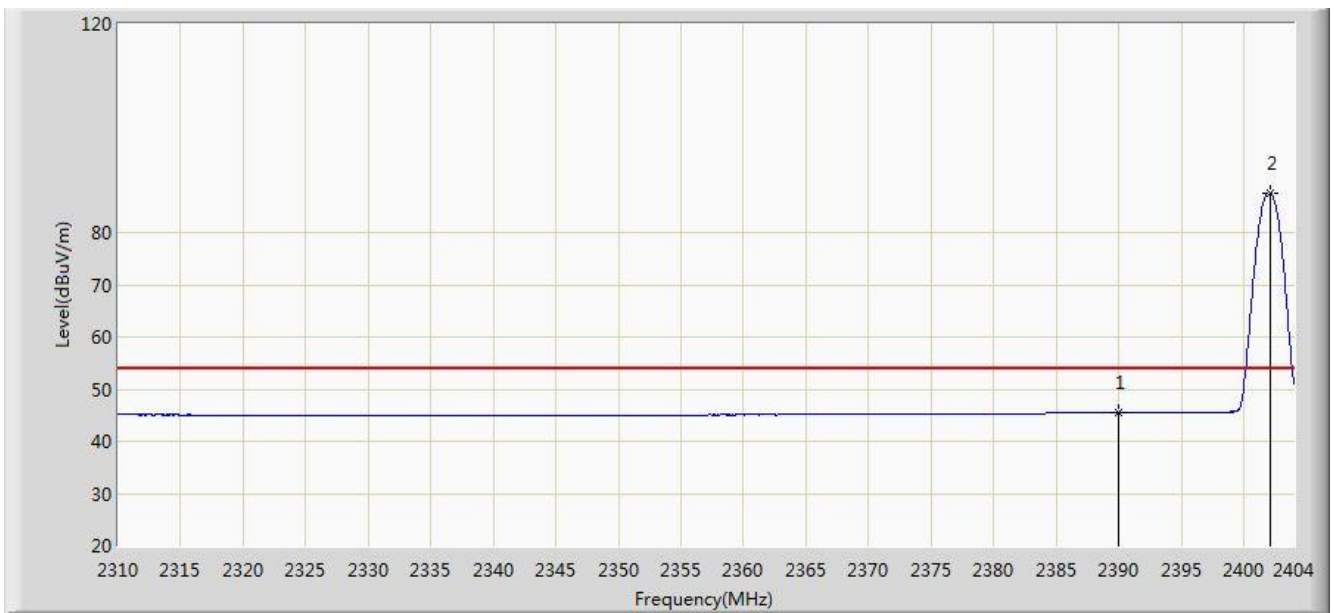

No	Flag	Mark	Frequency (MHz)	Measure Level (dBuV/m)	Reading Level (dBuV)	Over Limit (dB)	Limit (dBuV/m)	Factor (dB)	Type
1			2390.000	45.467	13.189	-8.533	54.000	32.278	AV
2		*	2402.073	87.681	55.407	N/A	N/A	32.273	AV

Site: AC2	Time: 2016/06/14 - 10:59
Limit: FCC_Part15.209_RE(3m)	Engineer: Roy Cheng
Probe: BBHA9120D_1-18GHz	Polarity: Vertical
EUT: Smart Phone	Power: AC 120V/60Hz
Test Mode: Transmit at channel 2402MHz by DH5	

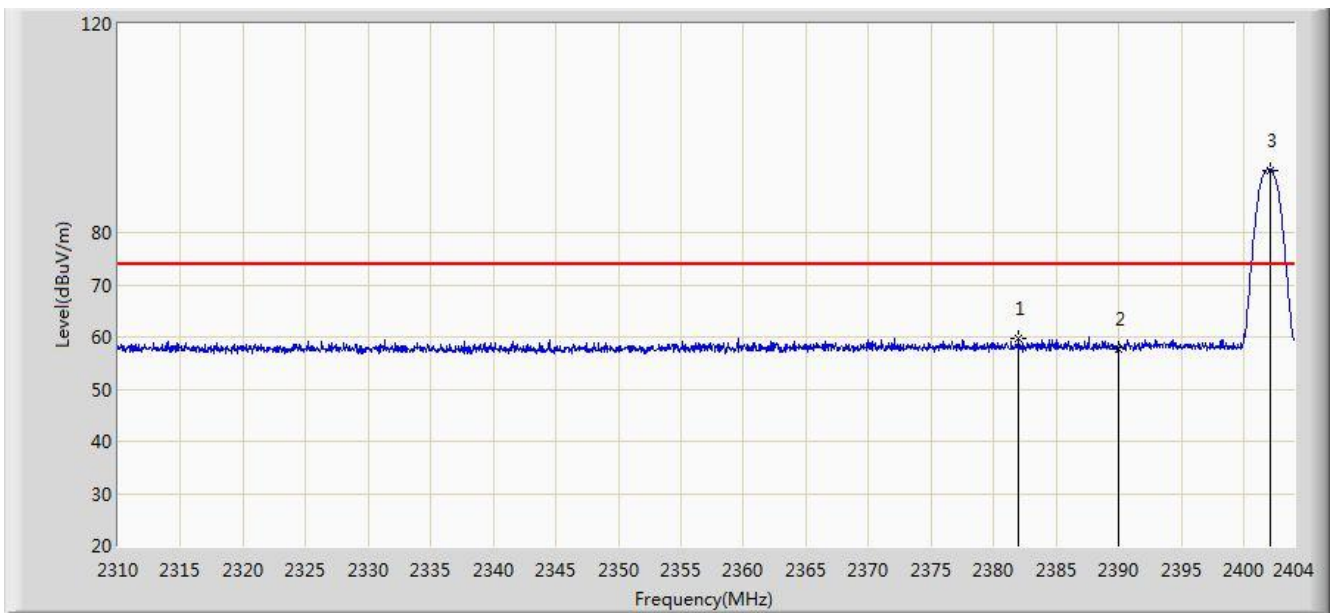

No	Flag	Mark	Frequency (MHz)	Measure Level (dBuV/m)	Reading Level (dBuV)	Over Limit (dB)	Limit (dBuV/m)	Factor (dB)	Type
1			2382.004	59.789	27.556	-14.211	74.000	32.234	PK
2			2390.000	57.779	25.501	-16.221	74.000	32.278	PK
3		*	2402.073	92.025	59.751	N/A	N/A	32.273	PK

Site: AC2	Time: 2016/06/14 - 11:01
Limit: FCC_Part15.209_RE(3m)	Engineer: Roy Cheng
Probe: BBHA9120D_1-18GHz	Polarity: Vertical
EUT: Smart Phone	Power: AC 120V/60Hz
Test Mode: Transmit at channel 2402MHz by DH5	

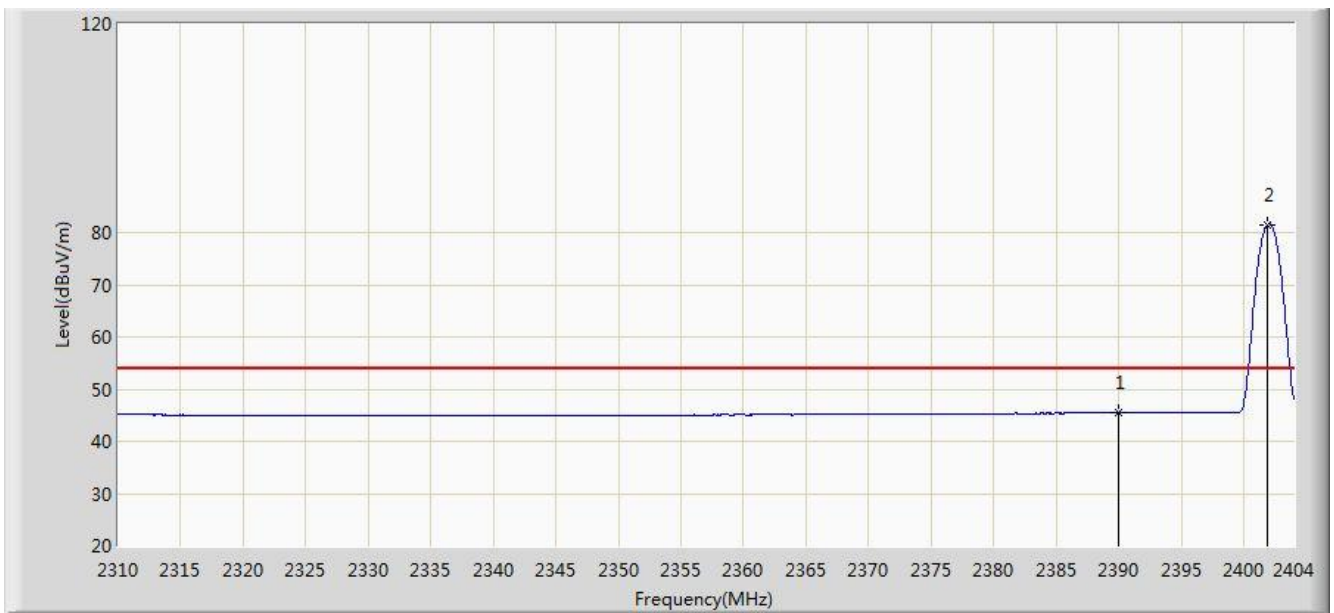

No	Flag	Mark	Frequency (MHz)	Measure Level (dBuV/m)	Reading Level (dBuV)	Over Limit (dB)	Limit (dBuV/m)	Factor (dB)	Type
1			2390.000	45.439	13.161	-8.561	54.000	32.278	AV
2		*	2401.885	81.393	49.119	N/A	N/A	32.274	AV

Site: AC2	Time: 2016/06/14 - 11:01
Limit: FCC_Part15.209_RE(3m)	Engineer: Roy Cheng
Probe: BBHA9120D_1-18GHz	Polarity: Horizontal
EUT: Smart Phone	Power: AC 120V/60Hz
Test Mode: Transmit at channel 2480MHz by DH5	

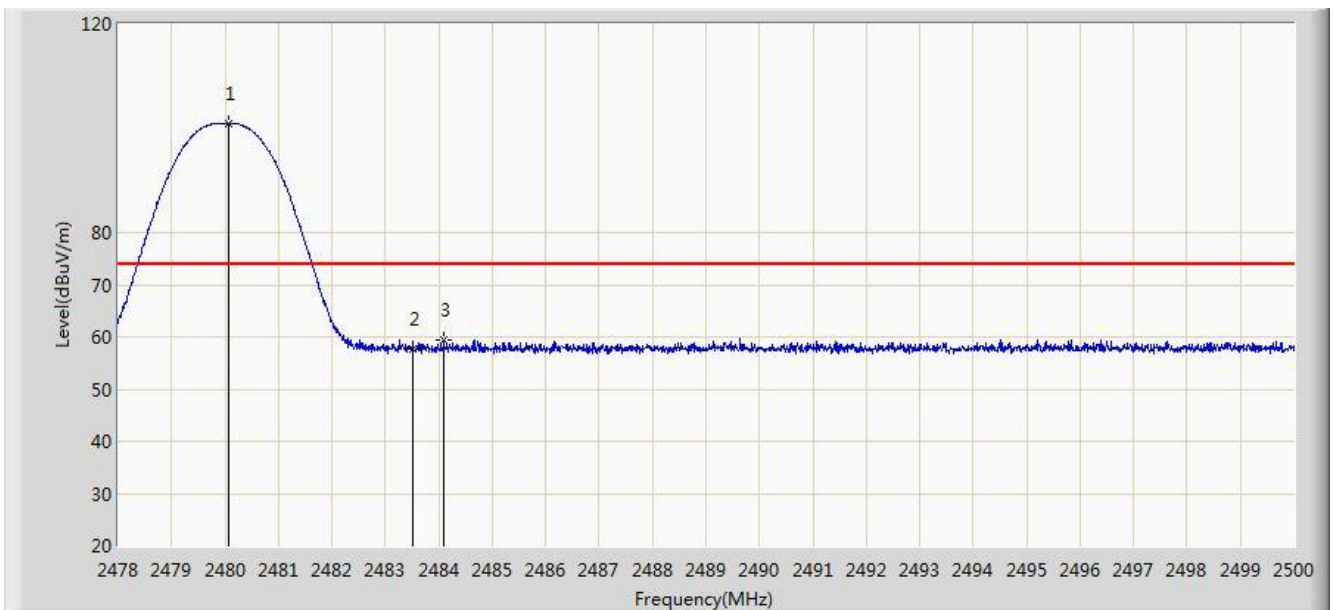

No	Flag	Mark	Frequency (MHz)	Measure Level (dBuV/m)	Reading Level (dBuV)	Over Limit (dB)	Limit (dBuV/m)	Factor (dB)	Type
1		*	2480.079	100.903	68.634	N/A	N/A	32.269	PK
2			2483.500	57.686	25.405	-16.314	74.000	32.282	PK
3			2484.094	59.300	27.017	-14.700	74.000	32.284	PK

Site: AC2	Time: 2016/06/14 - 11:03
Limit: FCC_Part15.209_RE(3m)	Engineer: Roy Cheng
Probe: BBHA9120D_1-18GHz	Polarity: Horizontal
EUT: Smart Phone	Power: AC 120V/60Hz
Test Mode: Transmit at channel 2480MHz by DH5	

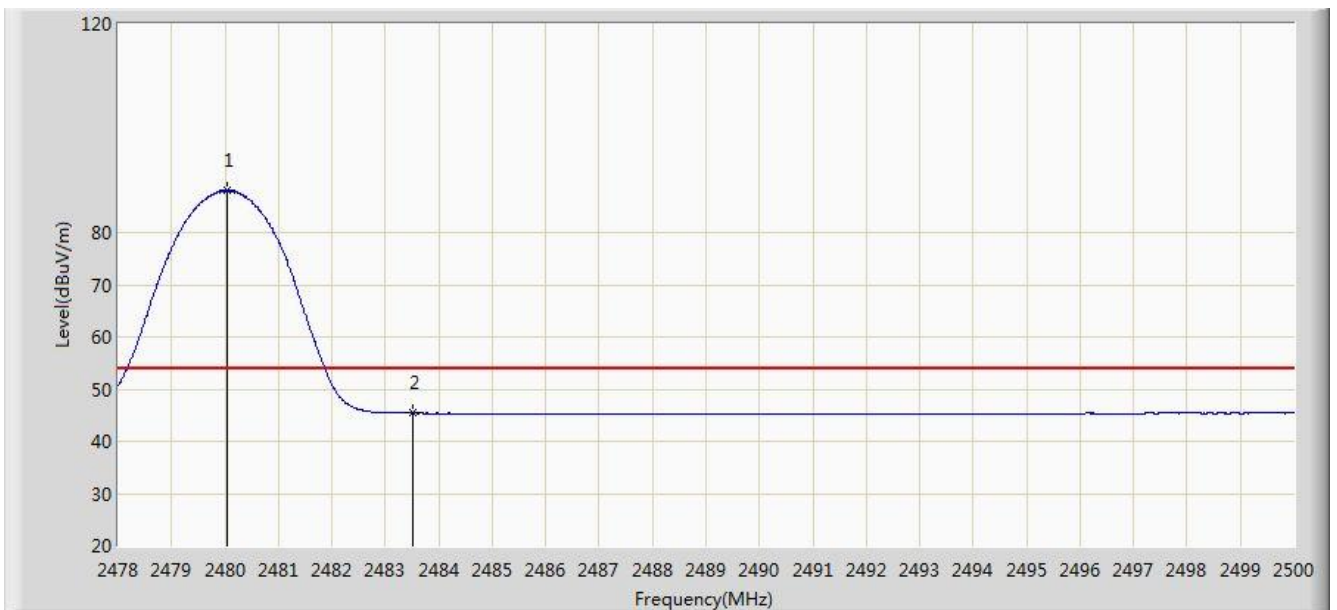

No	Flag	Mark	Frequency (MHz)	Measure Level (dBuV/m)	Reading Level (dBuV)	Over Limit (dB)	Limit (dBuV/m)	Factor (dB)	Type
1		*	2480.046	88.022	55.753	N/A	N/A	32.269	AV
2			2483.500	45.410	13.129	-8.590	54.000	32.282	AV

Site: AC2	Time: 2016/06/14 - 11:03
Limit: FCC_Part15.209_RE(3m)	Engineer: Roy Cheng
Probe: BBHA9120D_1-18GHz	Polarity: Vertical
EUT: Smart Phone	Power: AC 120V/60Hz
Test Mode: Transmit at channel 2480MHz by DH5	

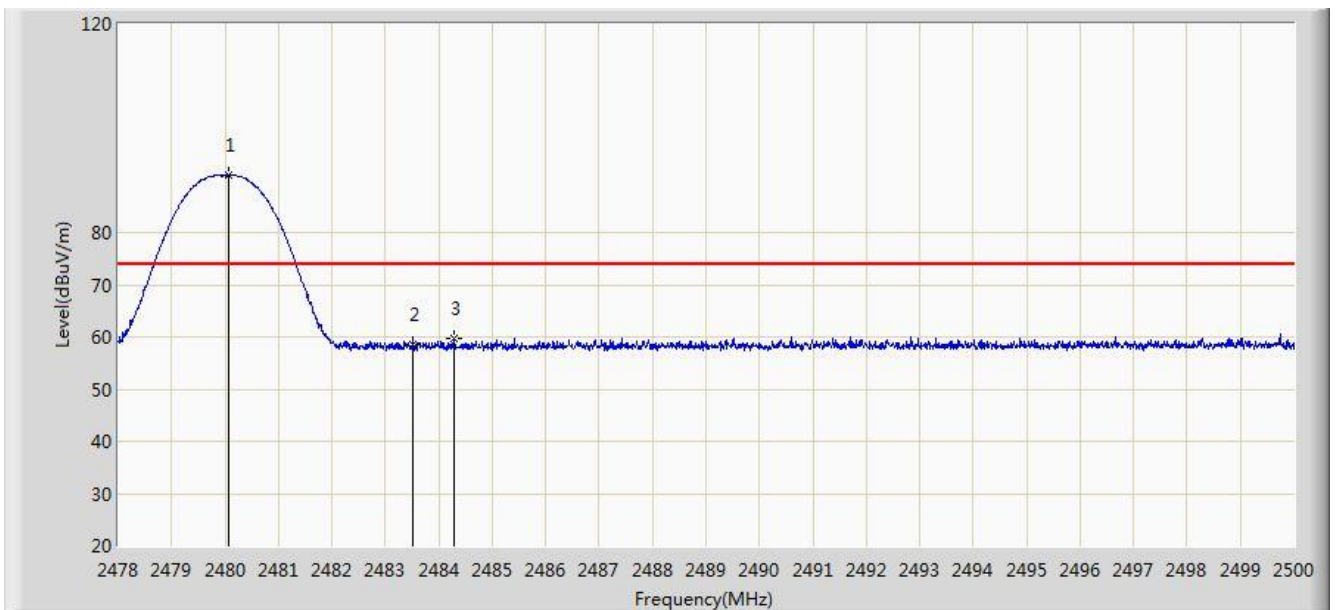

No	Flag	Mark	Frequency (MHz)	Measure Level (dBuV/m)	Reading Level (dBuV)	Over Limit (dB)	Limit (dBuV/m)	Factor (dB)	Type
1		*	2480.079	90.952	58.683	N/A	N/A	32.269	PK
2			2483.500	58.460	26.179	-15.540	74.000	32.282	PK
3			2484.292	59.800	27.516	-14.200	74.000	32.284	PK

Site: AC2	Time: 2016/06/14 - 11:06
Limit: FCC_Part15.209_RE(3m)	Engineer: Roy Cheng
Probe: BBHA9120D_1-18GHz	Polarity: Vertical
EUT: Smart Phone	Power: AC 120V/60Hz
Test Mode: Transmit at channel 2480MHz by DH5	

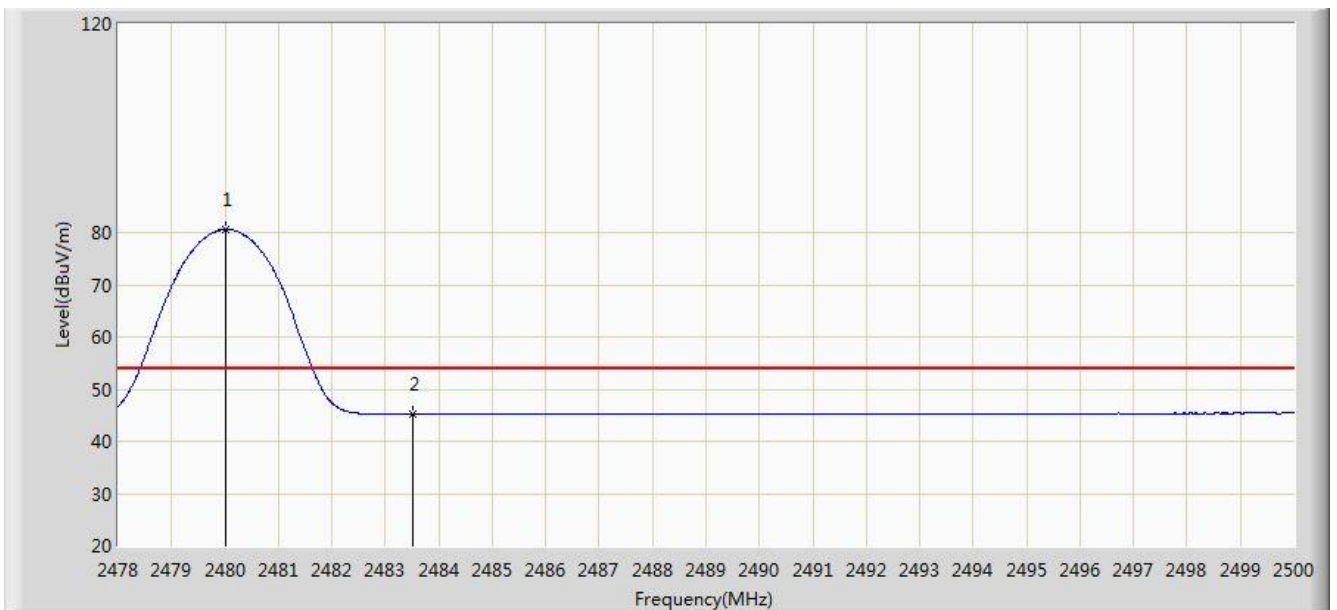

No	Flag	Mark	Frequency (MHz)	Measure Level (dBuV/m)	Reading Level (dBuV)	Over Limit (dB)	Limit (dBuV/m)	Factor (dB)	Type
1		*	2480.002	80.598	48.329	N/A	N/A	32.269	AV
2			2483.500	45.145	12.864	-8.855	54.000	32.282	AV

Site: AC2	Time: 2016/06/14 - 11:07
Limit: FCC_Part15.209_RE(3m)	Engineer: Roy Cheng
Probe: BBHA9120D_1-18GHz	Polarity: Horizontal
EUT: Smart Phone	Power: AC 120V/60Hz
Test Mode: Transmit at channel 2402MHz by 2DH5	

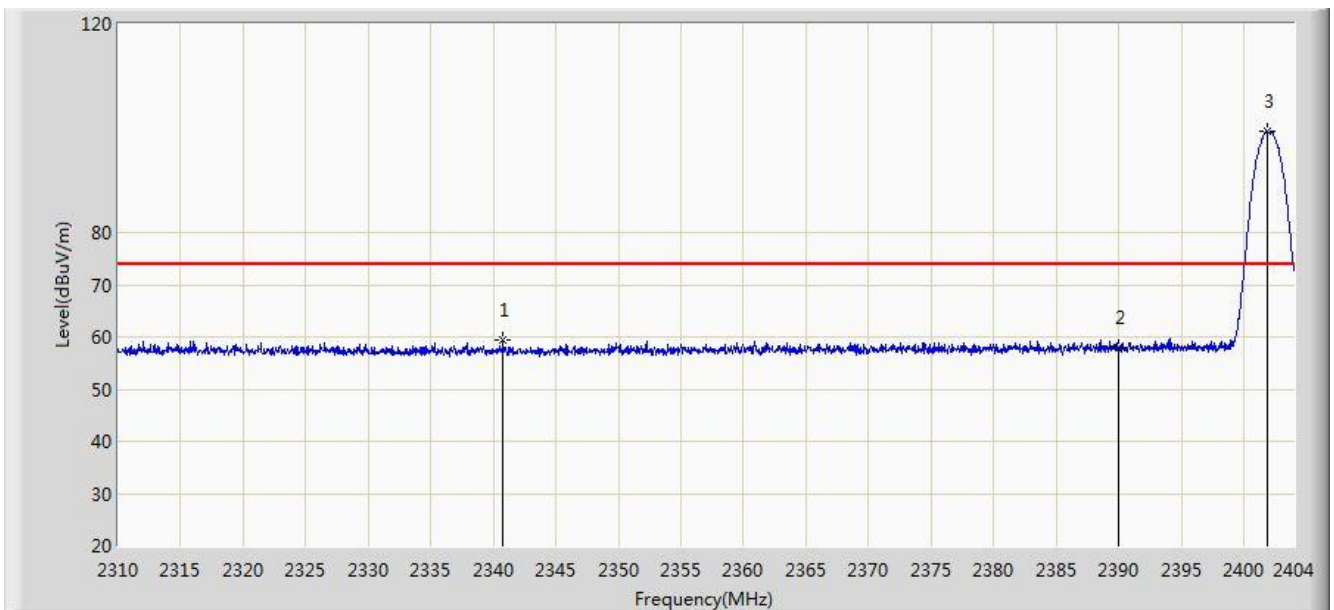

No	Flag	Mark	Frequency (MHz)	Measure Level (dBuV/m)	Reading Level (dBuV)	Over Limit (dB)	Limit (dBuV/m)	Factor (dB)	Type
1			2340.785	59.407	27.096	-14.593	74.000	32.311	PK
2			2390.000	57.977	25.699	-16.023	74.000	32.278	PK
3		*	2401.885	99.282	67.008	N/A	N/A	32.274	PK

Site: AC2	Time: 2016/06/14 - 11:09
Limit: FCC_Part15.209_RE(3m)	Engineer: Roy Cheng
Probe: BBHA9120D_1-18GHz	Polarity: Horizontal
EUT: Smart Phone	Power: AC 120V/60Hz
Test Mode: Transmit at channel 2402MHz by 2DH5	

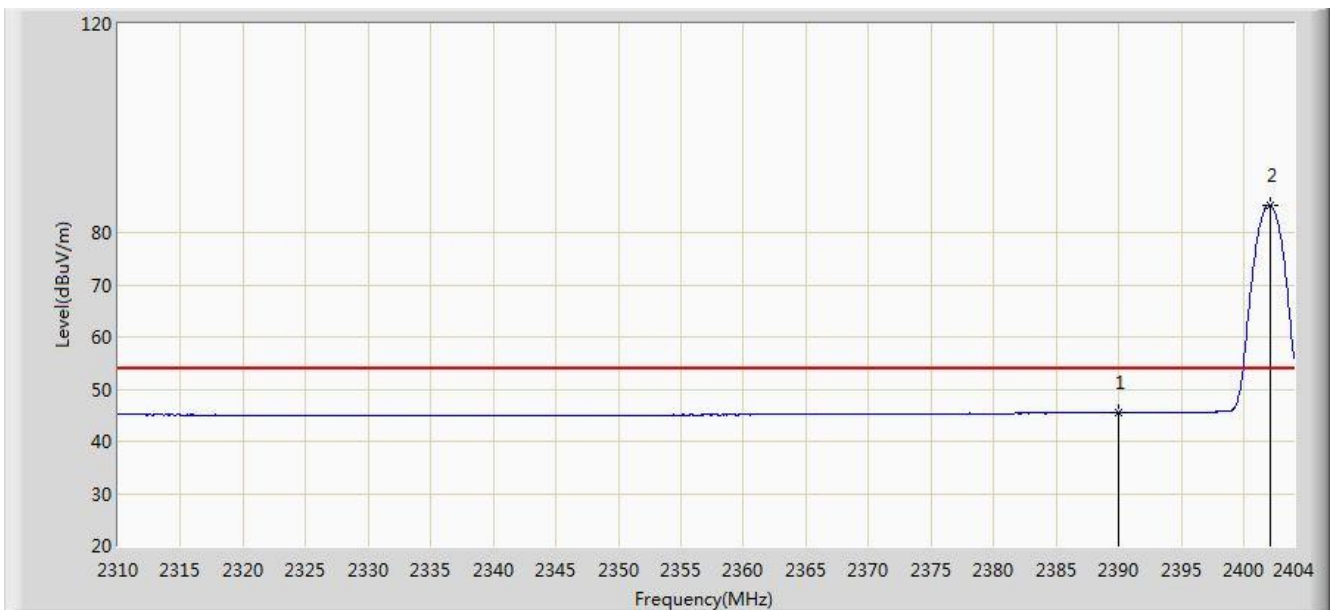

No	Flag	Mark	Frequency (MHz)	Measure Level (dBuV/m)	Reading Level (dBuV)	Over Limit (dB)	Limit (dBuV/m)	Factor (dB)	Type
1			2390.000	45.483	13.205	-8.517	54.000	32.278	AV
2		*	2402.073	85.309	53.035	N/A	N/A	32.273	AV

Site: AC2	Time: 2016/06/14 - 11:10
Limit: FCC_Part15.209_RE(3m)	Engineer: Roy Cheng
Probe: BBHA9120D_1-18GHz	Polarity: Vertical
EUT: Smart Phone	Power: AC 120V/60Hz
Test Mode: Transmit at channel 2402MHz by 2DH5	

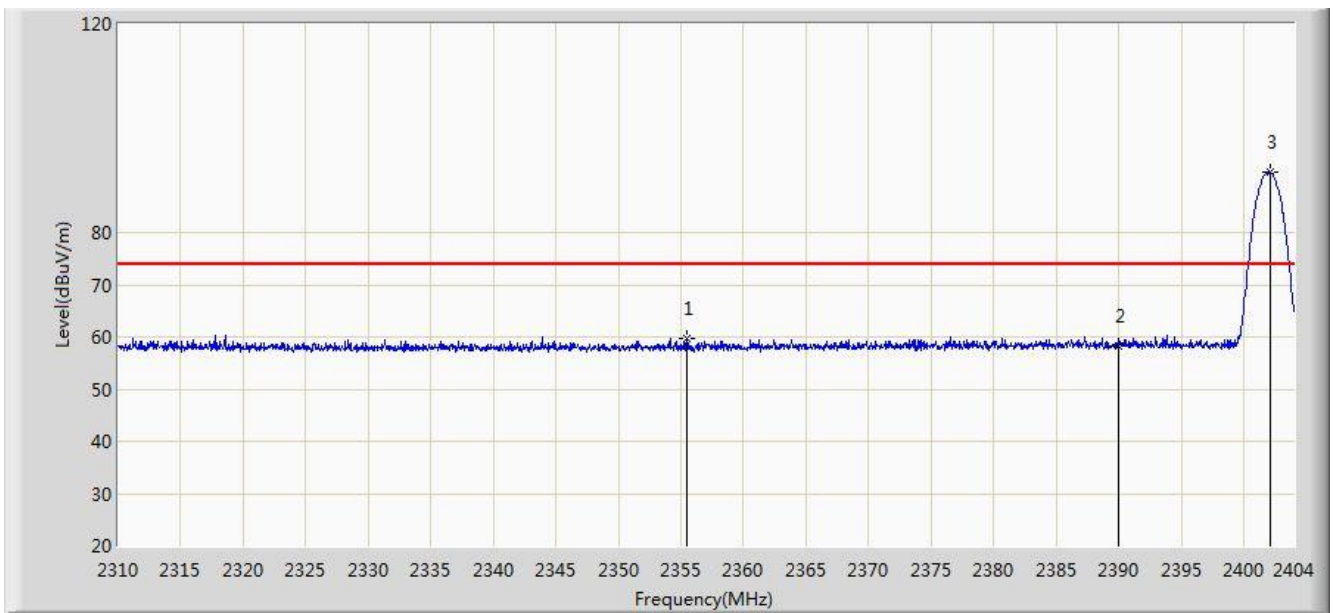

No	Flag	Mark	Frequency (MHz)	Measure Level (dBuV/m)	Reading Level (dBuV)	Over Limit (dB)	Limit (dBuV/m)	Factor (dB)	Type
1			2355.449	59.719	27.458	-14.281	74.000	32.261	PK
2			2390.000	58.213	25.935	-15.787	74.000	32.278	PK
3		*	2402.120	91.590	59.317	N/A	N/A	32.273	PK

Site: AC2	Time: 2016/06/14 - 11:13
Limit: FCC_Part15.209_RE(3m)	Engineer: Roy Cheng
Probe: BBHA9120D_1-18GHz	Polarity: Vertical
EUT: Smart Phone	Power: AC 120V/60Hz
Test Mode: Transmit at channel 2402MHz by 2DH5	

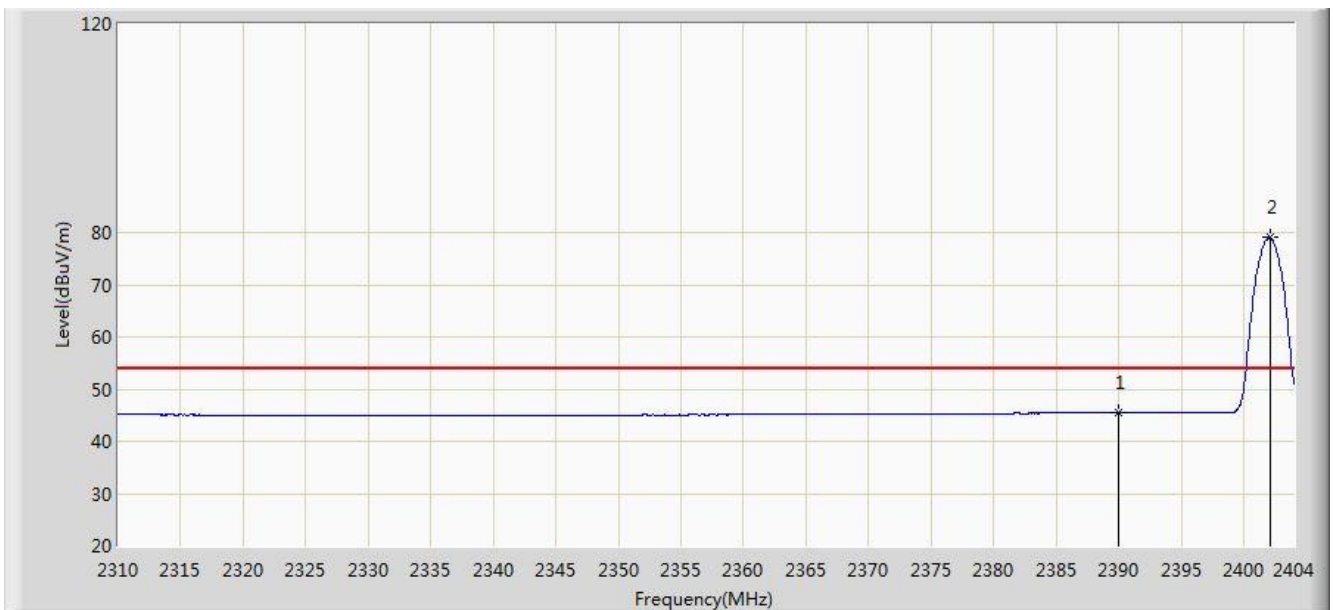

No	Flag	Mark	Frequency (MHz)	Measure Level (dBuV/m)	Reading Level (dBuV)	Over Limit (dB)	Limit (dBuV/m)	Factor (dB)	Type
1			2390.000	45.472	13.194	-8.528	54.000	32.278	AV
2		*	2402.073	79.111	46.837	N/A	N/A	32.273	AV

Site: AC2	Time: 2016/06/14 - 11:14
Limit: FCC_Part15.209_RE(3m)	Engineer: Roy Cheng
Probe: BBHA9120D_1-18GHz	Polarity: Horizontal
EUT: Smart Phone	Power: AC 120V/60Hz
Test Mode: Transmit at channel 2480MHz by 2DH5	

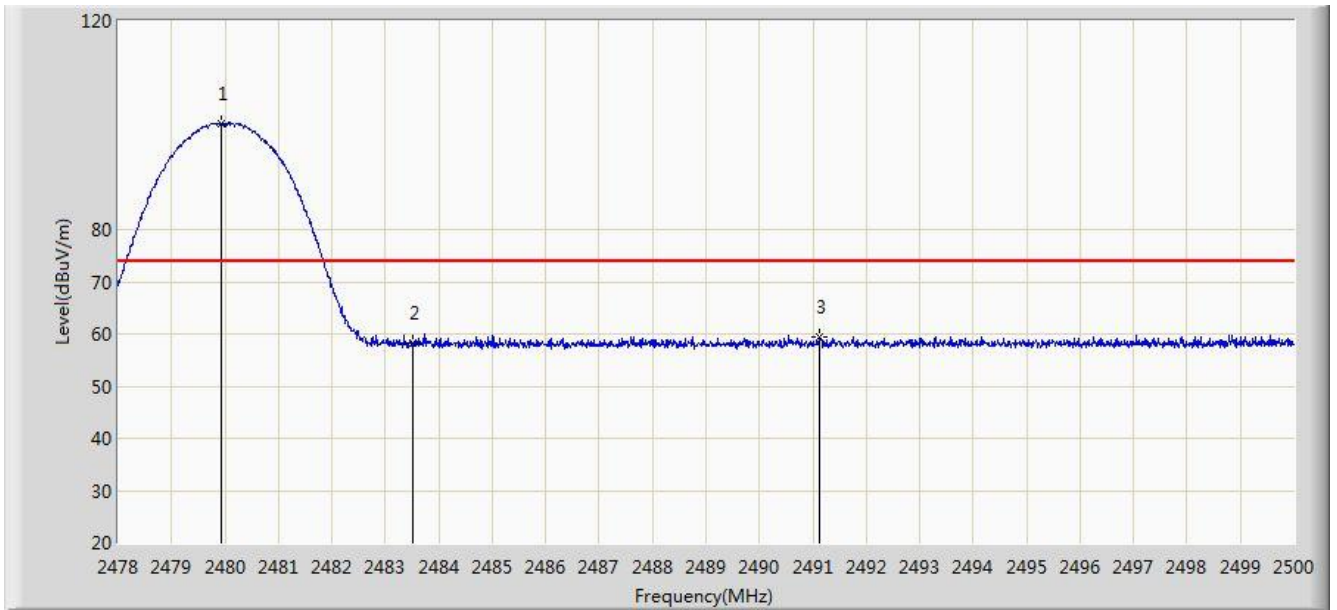

No	Flag	Mark	Frequency (MHz)	Measure Level (dBuV/m)	Reading Level (dBuV)	Over Limit (dB)	Limit (dBuV/m)	Factor (dB)	Type
1		*	2479.936	100.319	68.050	N/A	N/A	32.269	PK
2			2483.500	58.386	26.105	-15.614	74.000	32.282	PK
3			2491.112	59.297	26.990	-14.703	74.000	32.307	PK

Site: AC2	Time: 2016/06/14 - 11:16
Limit: FCC_Part15.209_RE(3m)	Engineer: Roy Cheng
Probe: BBHA9120D_1-18GHz	Polarity: Horizontal
EUT: Smart Phone	Power: AC 120V/60Hz
Test Mode: Transmit at channel 2480MHz by 2DH5	

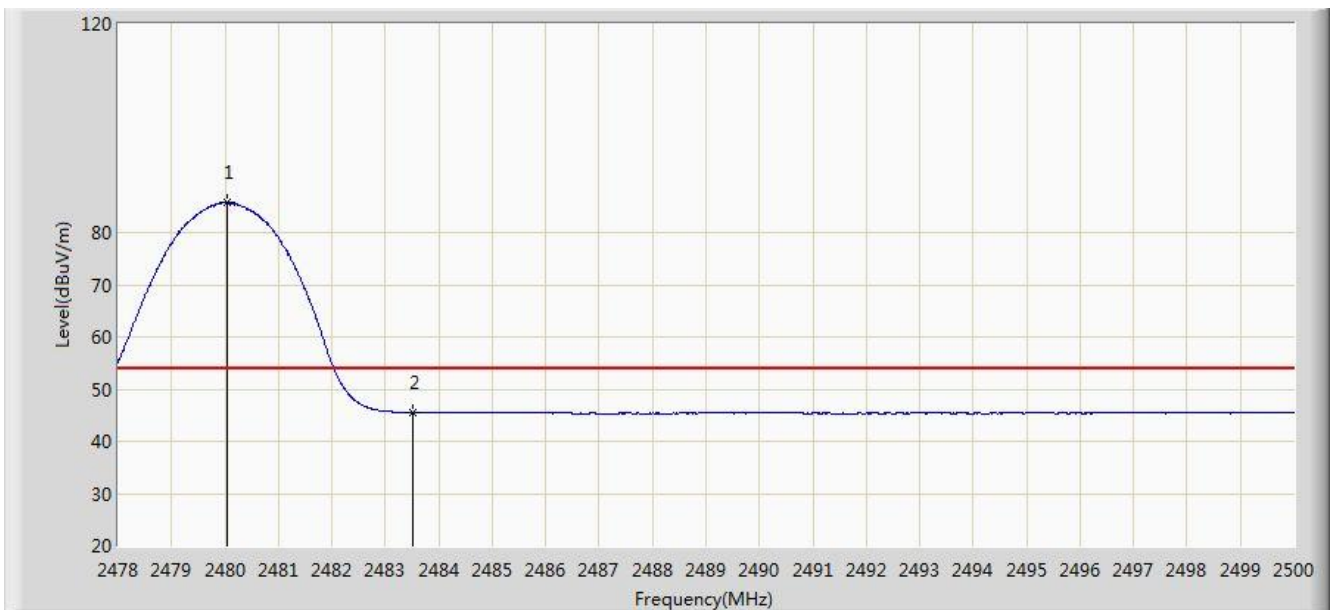

No	Flag	Mark	Frequency (MHz)	Measure Level (dBuV/m)	Reading Level (dBuV)	Over Limit (dB)	Limit (dBuV/m)	Factor (dB)	Type
1		*	2480.046	85.759	53.490	N/A	N/A	32.269	AV
2			2483.500	45.486	13.205	-8.514	54.000	32.282	AV

Site: AC2	Time: 2016/06/14 - 11:16
Limit: FCC_Part15.209_RE(3m)	Engineer: Roy Cheng
Probe: BBHA9120D_1-18GHz	Polarity: Vertical
EUT: Smart Phone	Power: AC 120V/60Hz
Test Mode: Transmit at channel 2480MHz by 2DH5	

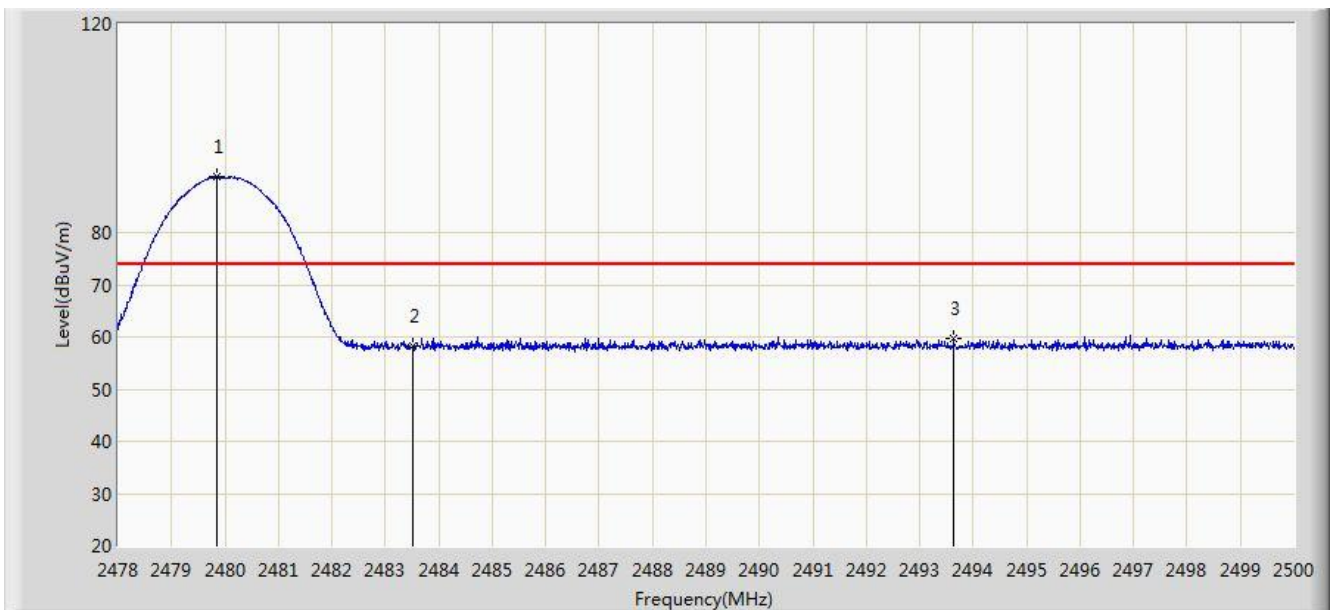

No	Flag	Mark	Frequency (MHz)	Measure Level (dBuV/m)	Reading Level (dBuV)	Over Limit (dB)	Limit (dBuV/m)	Factor (dB)	Type
1		*	2479.837	90.680	58.411	N/A	N/A	32.269	PK
2			2483.500	58.241	25.960	-15.759	74.000	32.282	PK
3			2493.631	59.647	27.331	-14.353	74.000	32.316	PK

Site: AC2	Time: 2016/06/14 - 11:18
Limit: FCC_Part15.209_RE(3m)	Engineer: Roy Cheng
Probe: BBHA9120D_1-18GHz	Polarity: Vertical
EUT: Smart Phone	Power: AC 120V/60Hz
Test Mode: Transmit at channel 2480MHz by 2DH5	

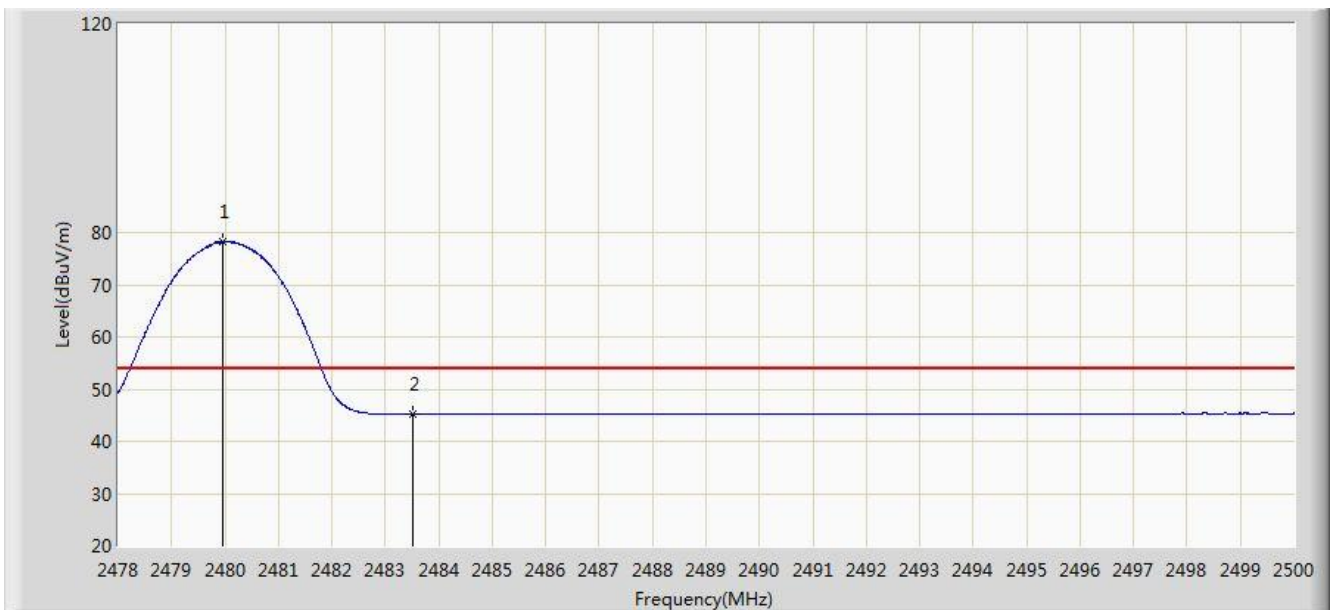

No	Flag	Mark	Frequency (MHz)	Measure Level (dBuV/m)	Reading Level (dBuV)	Over Limit (dB)	Limit (dBuV/m)	Factor (dB)	Type
1		*	2479.969	78.331	46.062	N/A	N/A	32.269	AV
2			2483.500	45.137	12.856	-8.863	54.000	32.282	AV

Site: AC2	Time: 2016/06/14 - 11:19
Limit: FCC_Part15.209_RE(3m)	Engineer: Roy Cheng
Probe: BBHA9120D_1-18GHz	Polarity: Horizontal
EUT: Smart Phone	Power: AC 120V/60Hz
Test Mode: Transmit at channel 2402MHz by 3DH5	

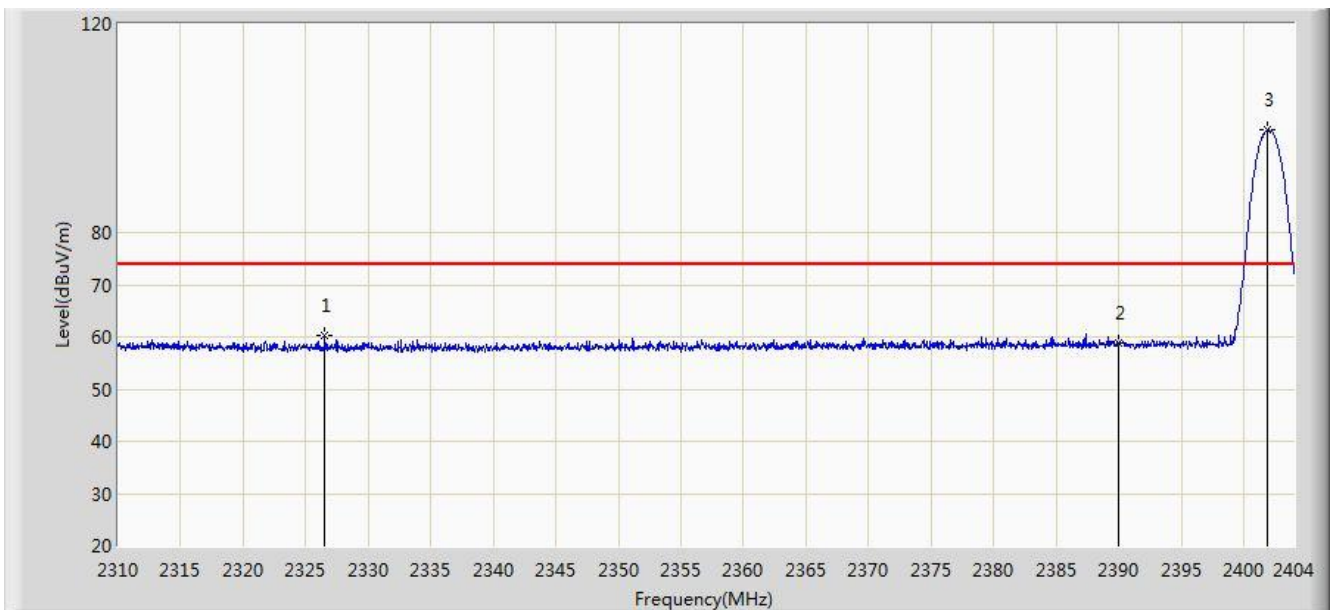

No	Flag	Mark	Frequency (MHz)	Measure Level (dBuV/m)	Reading Level (dBuV)	Over Limit (dB)	Limit (dBuV/m)	Factor (dB)	Type
1			2326.544	60.322	27.944	-13.678	74.000	32.378	PK
2			2390.000	58.787	26.509	-15.213	74.000	32.278	PK
3		*	2401.885	99.604	67.330	N/A	N/A	32.274	PK

Site: AC2	Time: 2016/06/14 - 11:26
Limit: FCC_Part15.209_RE(3m)	Engineer: Roy Cheng
Probe: BBHA9120D_1-18GHz	Polarity: Horizontal
EUT: Smart Phone	Power: AC 120V/60Hz
Test Mode: Transmit at channel 2402MHz by 3DH5	

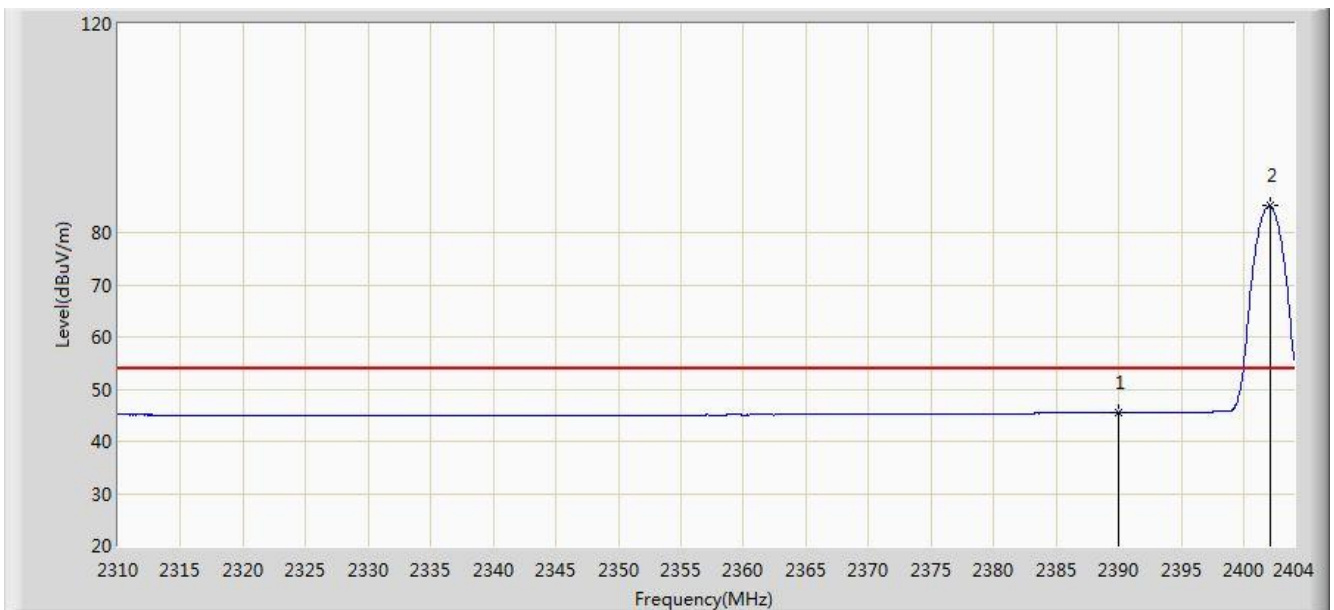

No	Flag	Mark	Frequency (MHz)	Measure Level (dBuV/m)	Reading Level (dBuV)	Over Limit (dB)	Limit (dBuV/m)	Factor (dB)	Type
1			2390.000	45.498	13.220	-8.502	54.000	32.278	AV
2		*	2402.073	85.117	52.843	N/A	N/A	32.273	AV

Site: AC2	Time: 2016/06/14 - 11:27
Limit: FCC_Part15.209_RE(3m)	Engineer: Roy Cheng
Probe: BBHA9120D_1-18GHz	Polarity: Vertical
EUT: Smart Phone	Power: AC 120V/60Hz
Test Mode: Transmit at channel 2402MHz by 3DH5	

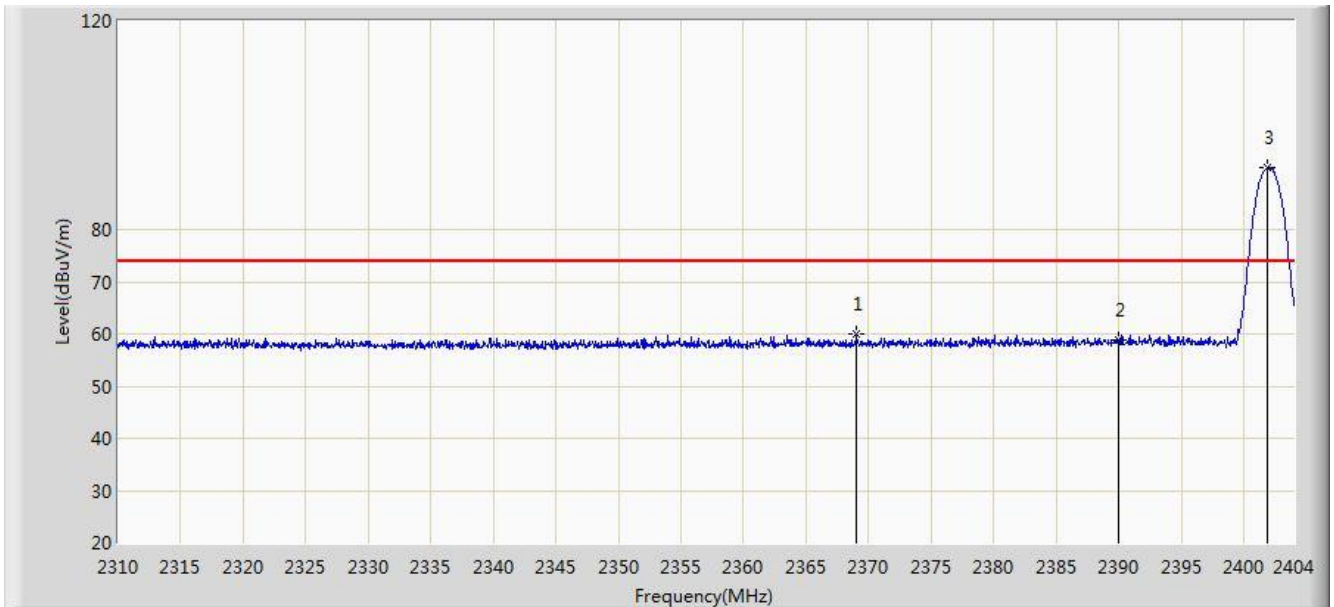

No	Flag	Mark	Frequency (MHz)	Measure Level (dBuV/m)	Reading Level (dBuV)	Over Limit (dB)	Limit (dBuV/m)	Factor (dB)	Type
1			2369.032	59.912	27.686	-14.088	74.000	32.226	PK
2			2390.000	58.770	26.492	-15.230	74.000	32.278	PK
3		*	2401.885	91.798	59.524	N/A	N/A	32.274	PK

Site: AC2	Time: 2016/06/14 - 11:31
Limit: FCC_Part15.209_RE(3m)	Engineer: Roy Cheng
Probe: BBHA9120D_1-18GHz	Polarity: Vertical
EUT: Smart Phone	Power: AC 120V/60Hz
Test Mode: Transmit at channel 2402MHz by 3DH5	

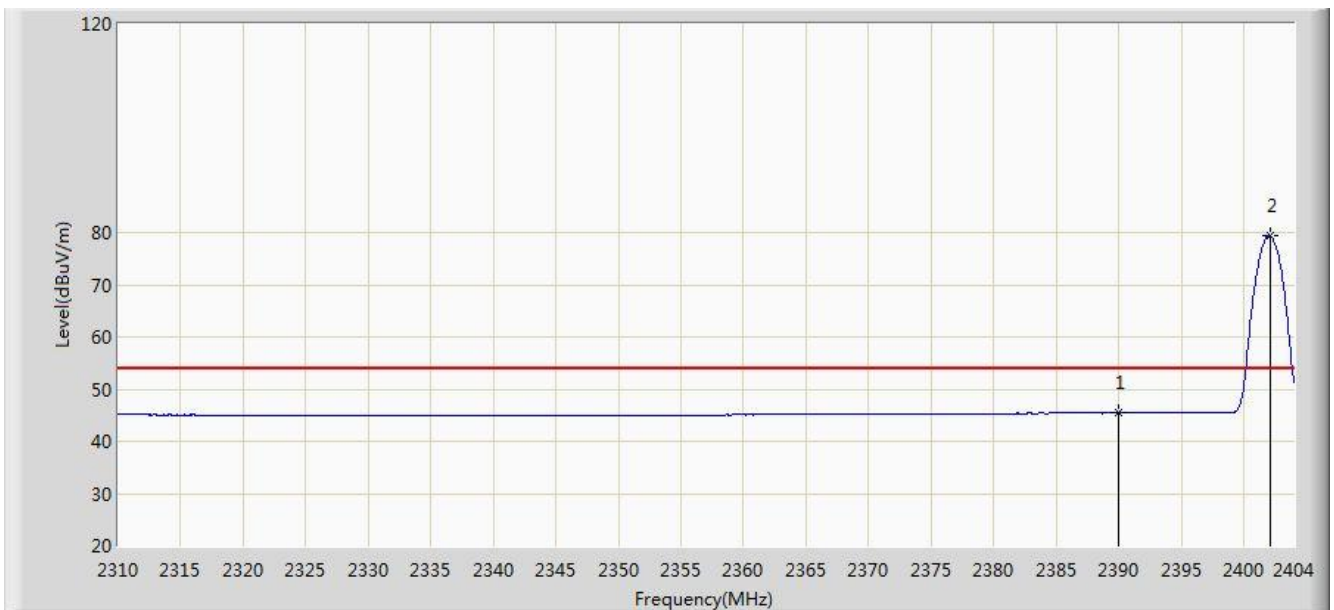

No	Flag	Mark	Frequency (MHz)	Measure Level (dBuV/m)	Reading Level (dBuV)	Over Limit (dB)	Limit (dBuV/m)	Factor (dB)	Type
1			2390.000	45.415	13.137	-8.585	54.000	32.278	AV
2		*	2402.073	79.397	47.123	N/A	N/A	32.273	AV

Site: AC2	Time: 2016/06/14 - 11:32
Limit: FCC_Part15.209_RE(3m)	Engineer: Roy Cheng
Probe: BBHA9120D_1-18GHz	Polarity: Horizontal
EUT: Smart Phone	Power: AC 120V/60Hz
Test Mode: Transmit at channel 2480MHz by 3DH5	

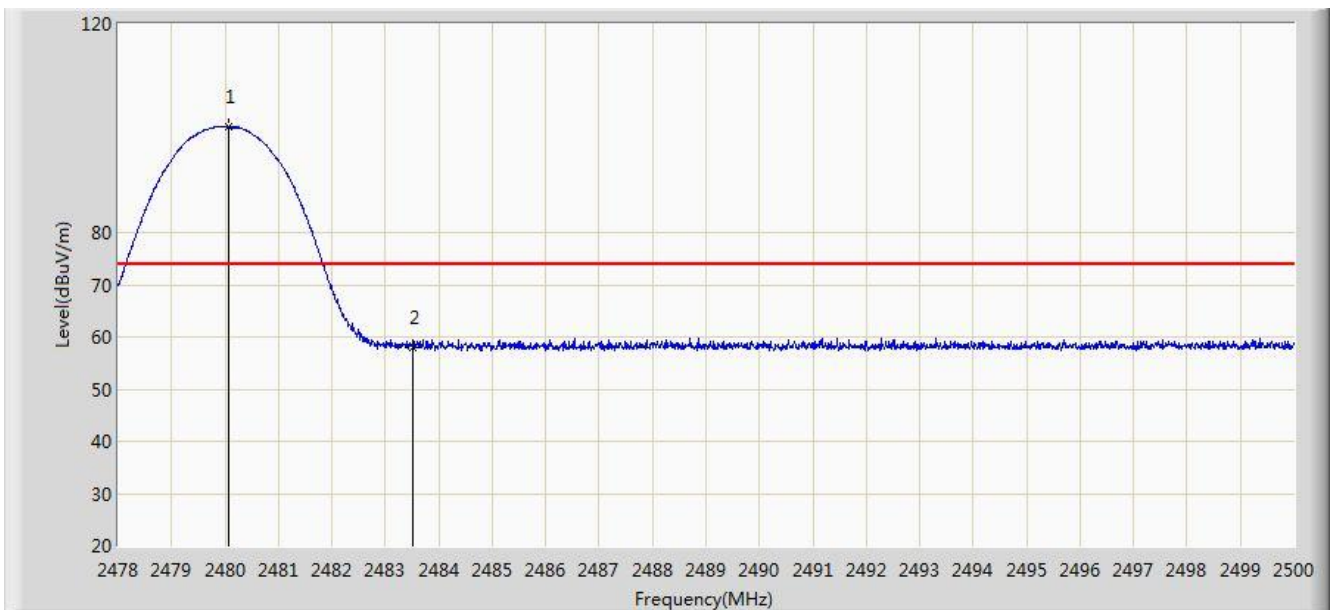

No	Flag	Mark	Frequency (MHz)	Measure Level (dBuV/m)	Reading Level (dBuV)	Over Limit (dB)	Limit (dBuV/m)	Factor (dB)	Type
1		*	2480.079	100.286	68.017	N/A	N/A	32.269	PK
2			2483.500	57.902	25.621	-16.098	74.000	32.282	PK

Site: AC2	Time: 2016/06/14 - 11:36
Limit: FCC_Part15.209_RE(3m)	Engineer: Roy Cheng
Probe: BBHA9120D_1-18GHz	Polarity: Horizontal
EUT: Smart Phone	Power: AC 120V/60Hz
Test Mode: Transmit at channel 2480MHz by 3DH5	

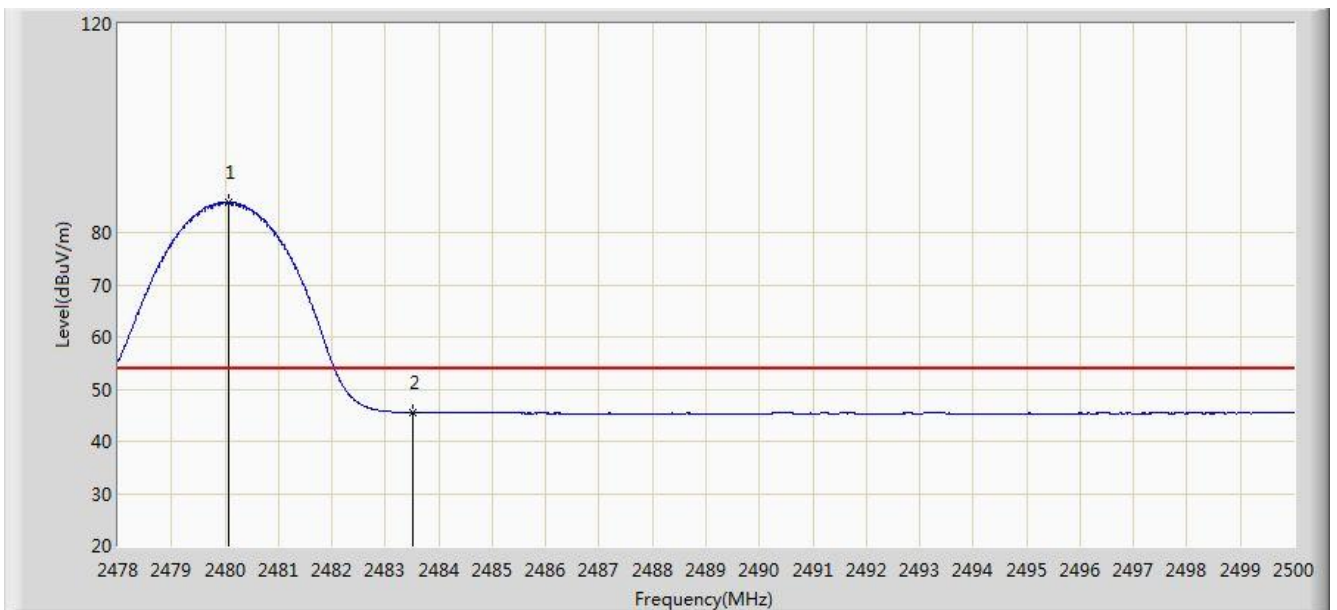

No	Flag	Mark	Frequency (MHz)	Measure Level (dBuV/m)	Reading Level (dBuV)	Over Limit (dB)	Limit (dBuV/m)	Factor (dB)	Type
1		*	2480.079	85.827	53.558	N/A	N/A	32.269	AV
2			2483.500	45.480	13.199	-8.520	54.000	32.282	AV

Site: AC2	Time: 2016/06/14 - 11:37
Limit: FCC_Part15.209_RE(3m)	Engineer: Roy Cheng
Probe: BBHA9120D_1-18GHz	Polarity: Vertical
EUT: Smart Phone	Power: AC 120V/60Hz
Test Mode: Transmit at channel 2480MHz by 3DH5	

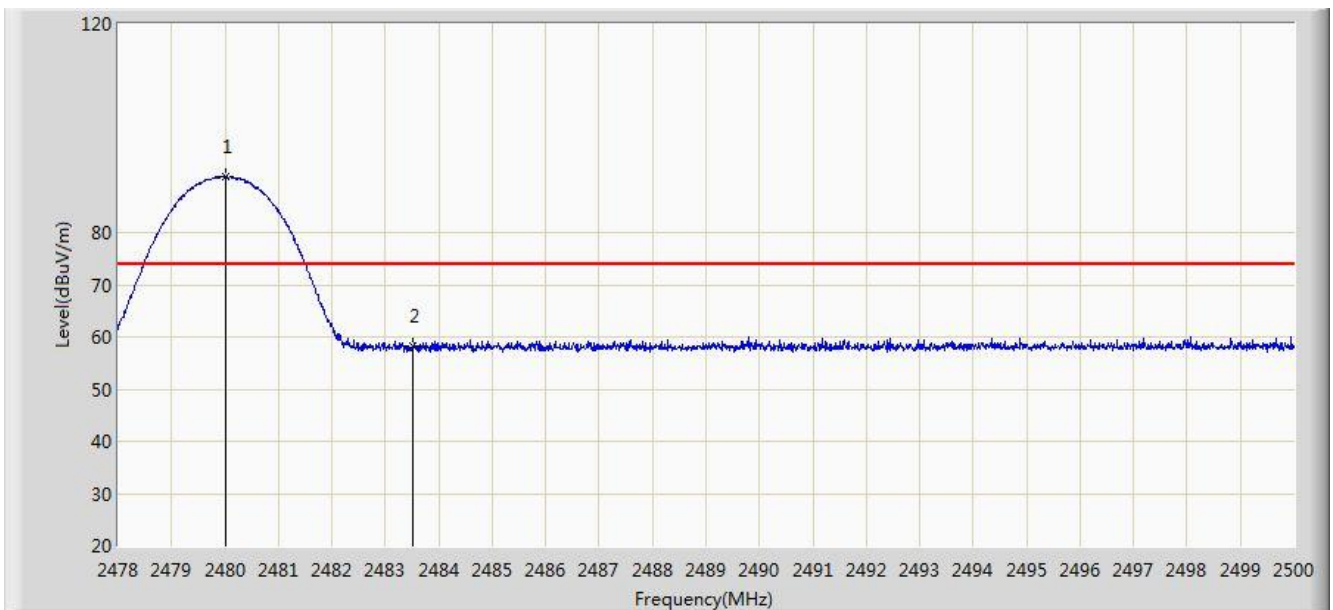

No	Flag	Mark	Frequency (MHz)	Measure Level (dBuV/m)	Reading Level (dBuV)	Over Limit (dB)	Limit (dBuV/m)	Factor (dB)	Type
1		*	2480.013	90.739	58.470	N/A	N/A	32.269	PK
2			2483.500	58.403	26.122	-15.597	74.000	32.282	PK

Note: Measure Level (dB μ V/m) = Reading Level (dB μ V) + Factor (dB)

Factor (dB) = Cable Loss (dB) + Antenna Factor (dB/m)

Site: AC2	Time: 2016/06/14 - 11:39
Limit: FCC_Part15.209_RE(3m)	Engineer: Roy Cheng
Probe: BBHA9120D_1-18GHz	Polarity: Vertical
EUT: Smart Phone	Power: AC 120V/60Hz
Test Mode: Transmit at channel 2480MHz by 3DH5	

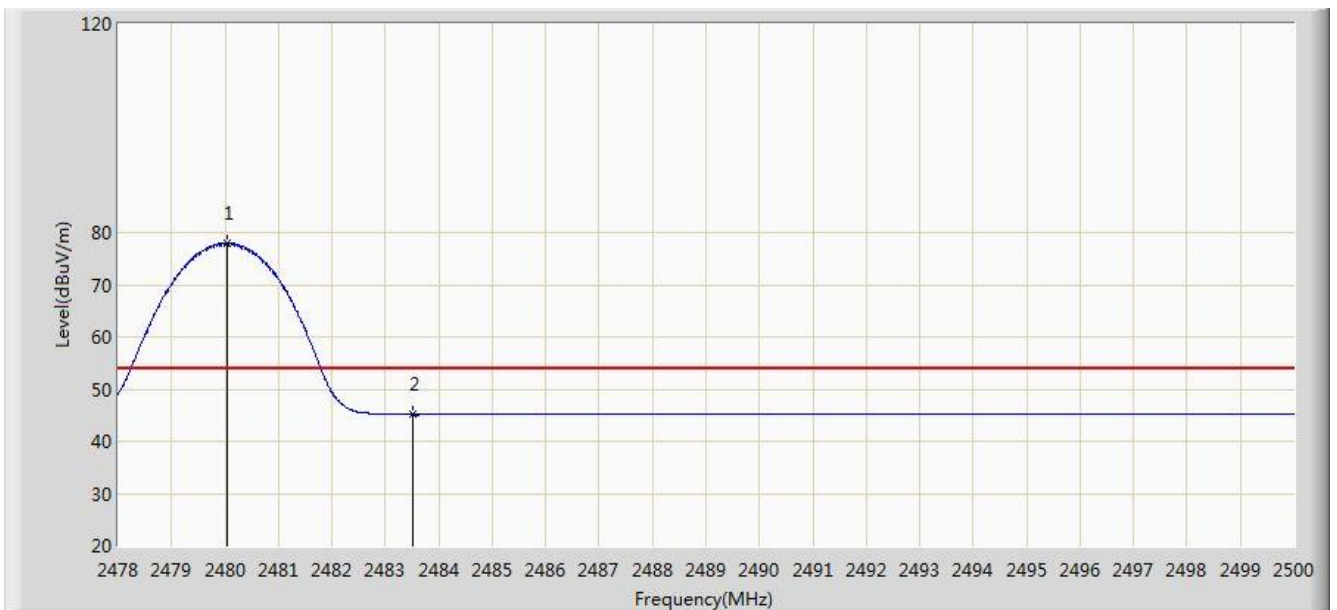

No	Flag	Mark	Frequency (MHz)	Measure Level (dBuV/m)	Reading Level (dBuV)	Over Limit (dB)	Limit (dBuV/m)	Factor (dB)	Type
1		*	2480.046	78.005	45.736	N/A	N/A	32.269	AV
2			2483.500	45.117	12.836	-8.883	54.000	32.282	AV

Note: Measure Level (dB μ V/m) = Reading Level (dB μ V) + Factor (dB)

Factor (dB) = Cable Loss (dB) + Antenna Factor (dB/m)

7.11. AC Conducted Emissions Measurement

7.11.1. Test Limit

FCC Part 15 Subpart C Paragraph 15.207 Limits		
Frequency (MHz)	QP (dB μ V)	Average (dB μ V)
0.15 - 0.50	66 - 56	56 - 46
0.50 - 5.0	56	46
5.0 - 30	60	50

Note 1: The lower limit shall apply at the transition frequencies.

Note 2: The limit decreases linearly with the logarithm of the frequency in the range 0.15MHz to 0.5MHz.

7.11.2. Test Setup

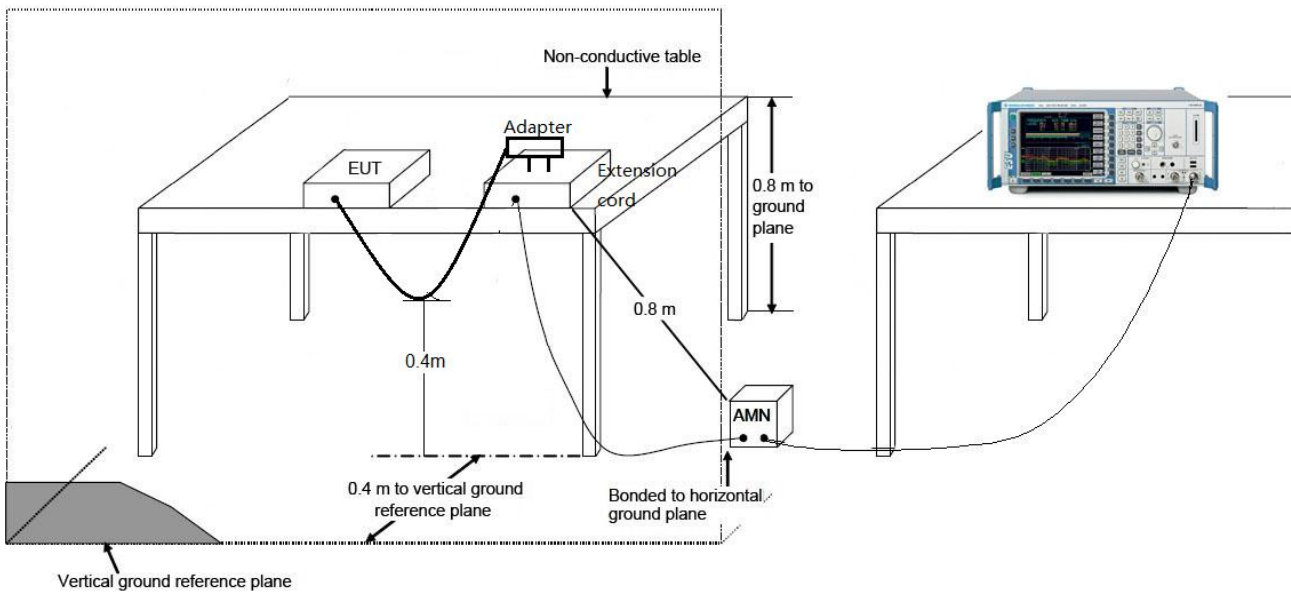

7.11.3. Test Result

Site: SR2	Time: 2016/06/12 - 18:12
Limit: FCC_Part15.207_CE_AC Power	Engineer: Dandy Li
Probe: ENV216_101683_Filter On	Polarity: Line
EUT: Smart Phone	Power: AC 120V/60Hz
Test Mode 1	

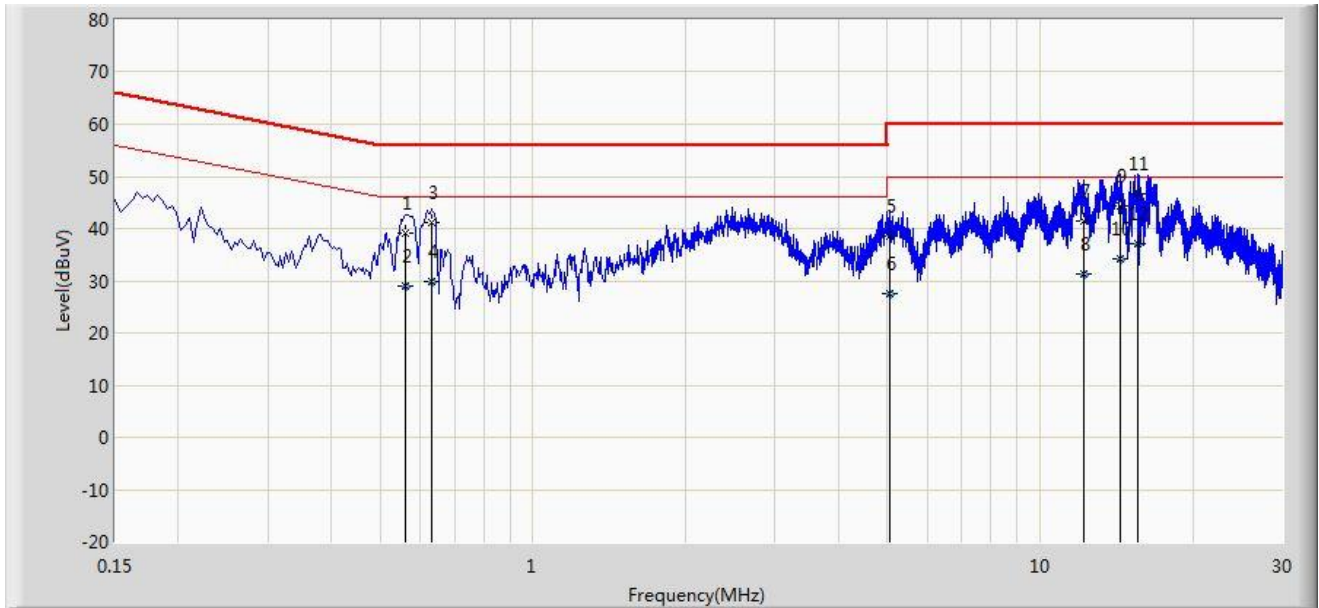

No	Flag	Mark	Frequency (MHz)	Measure Level (dBuV)	Reading Level (dBuV)	Over Limit (dB)	Limit (dBuV)	Factor	Type
1			0.562	39.091	28.957	-16.909	56.000	10.135	QP
2			0.562	28.902	18.767	-17.098	46.000	10.135	AV
3			0.630	41.046	30.947	-14.954	56.000	10.099	QP
4			0.630	29.829	19.730	-16.171	46.000	10.099	AV
5			5.052	38.504	28.465	-21.496	60.000	10.039	QP
6			5.052	27.582	17.544	-22.418	50.000	10.039	AV
7			12.166	41.570	31.475	-18.430	60.000	10.095	QP
8			12.166	31.259	21.164	-18.741	50.000	10.095	AV
9			14.426	44.419	34.374	-15.581	60.000	10.045	QP
10			14.426	34.109	24.064	-15.891	50.000	10.045	AV
11			15.610	46.721	36.662	-13.279	60.000	10.059	QP
12		*	15.610	37.097	27.038	-12.903	50.000	10.059	AV

Note: Measure Level (dBuV) = Reading Level (dBuV) + Factor (dB)

Factor (dB) = Cable Loss (dB) + LISN Factor (dB)

Site: SR2	Time: 2016/06/12 - 18:19
Limit: FCC_Part15.207_CE_AC Power	Engineer: Dandy Li
Probe: ENV216_101683_Filter On	Polarity: Neutral
EUT: Smart Phone	Power: AC 120V/60Hz
Test Mode 1	

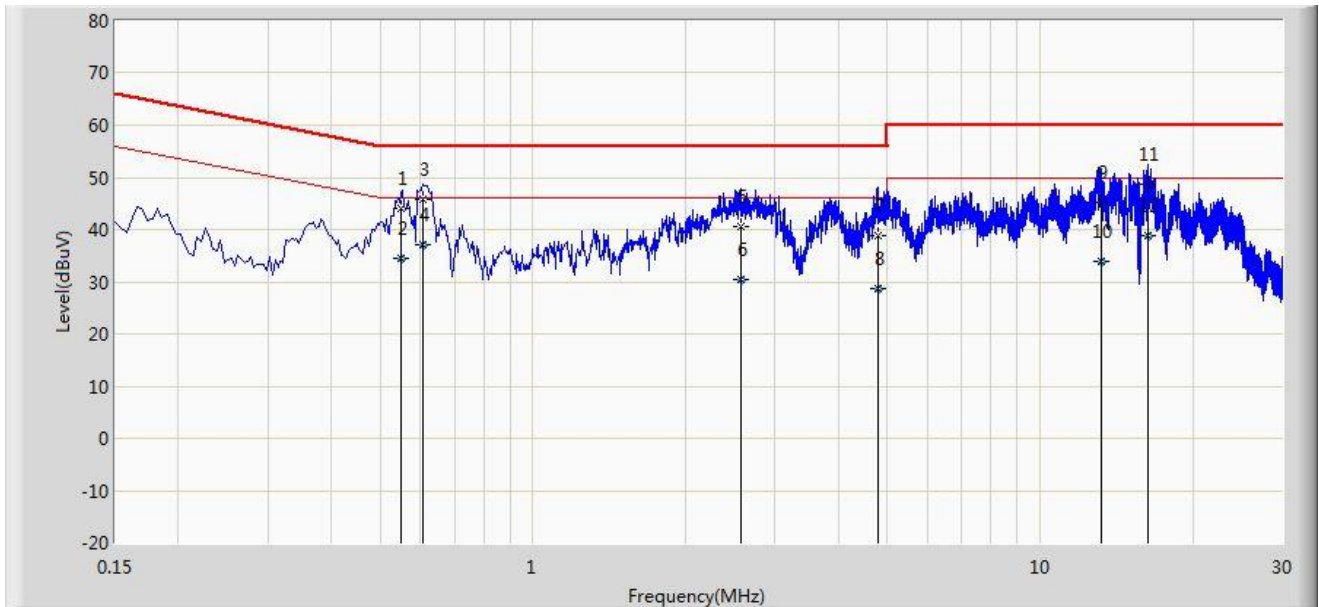

No	Flag	Mark	Frequency (MHz)	Measure Level (dBuV)	Reading Level (dBuV)	Over Limit (dB)	Limit (dBuV)	Factor	Type
1			0.550	44.008	33.849	-11.992	56.000	10.159	QP
2			0.550	34.394	24.236	-11.606	46.000	10.159	AV
3			0.606	45.696	35.568	-10.304	56.000	10.128	QP
4		*	0.606	37.020	26.892	-8.980	46.000	10.128	AV
5			2.566	40.556	30.697	-15.444	56.000	9.859	QP
6			2.566	30.437	20.579	-15.563	46.000	9.859	AV
7			4.778	38.930	28.899	-17.070	56.000	10.031	QP
8			4.778	28.613	18.582	-17.387	46.000	10.031	AV
9			13.154	45.248	35.149	-14.752	60.000	10.099	QP
10			13.154	33.951	23.851	-16.049	50.000	10.099	AV
11			16.326	48.568	38.457	-11.432	60.000	10.111	QP
12			16.326	38.696	28.585	-11.304	50.000	10.111	AV

Note: Measure Level (dBμV) = Reading Level (dBμV) + Factor (dB)

Factor (dB) = Cable Loss (dB) + LISN Factor (dB)

8. CONCLUSION

The data collected relate only the item(s) tested and show that the **Smart Phone** is in compliance with Part 15C of the FCC Rules.

————— The End —————