



MEASUREMENT REPORT

FCC PART 22&24 Portable Handset

FCC ID 2AIV6-T196

APPLICANT Shenzhen Inrico Electronics Co.,Ltd

Application Type Certification

Product Smart Phone

Model No. T196

Brand Name Inrico

FCC Classification PCS Licensed Transmitter Held to Face (PCF)

FCC Rule Part(s) Part2, Part22 Subpart H, Part24 Subpart E

Test Procedure(s) ANSI/TIA-603-D-2010, KDB 971168 D01v02r02

Test Date June 01 ~ 30, 2017

Reviewed By : Kevin Guo
(Kevin Guo)

Approved By : Marlin Chen
(Marlin Chen)



The test results relate only to the samples tested.

This equipment has been shown to be capable of compliance with the applicable technical standards as indicated in the measurement report and was tested in accordance with the measurement procedures specified in §2.947. Test results reported herein relate only to the item(s) tested.

The test report shall not be reproduced except in full without the written approval of MRT Technology (Suzhou) Co., Ltd.

Revision History

Report No.	Version	Description	Issue Date	Note
1706RSU01501	Rev. 01	Initial report	06-26-2017	Valid

CONTENTS

Description	Page
§2.1033 General Information	5
1. INTRODUCTION	6
1.1. Scope	6
1.2. MRT Test Location	6
2. PRODUCT INFORMATION	7
2.1. Equipment Description	7
2.2. Device Capabilities	7
2.3. Test Configuration	8
2.4. EMI Suppression Device(s)/Modifications	8
3. DESCRIPTION OF TEST	9
3.1. Evaluation Procedure	9
3.2. Cellular – Base Frequency Blocks	9
3.3. Cellular – Mobile Frequency Blocks	9
3.4. PCS – Base Frequency Blocks	9
3.5. PCS – Mobile Frequency Blocks	10
3.6. Occupied Bandwidth	10
3.7. Spurious and Harmonic Emissions at Antenna Terminal	10
3.8. Radiated Power and Radiated Spurious Emissions	11
3.9. Peak-Average Ratio	12
3.10. Frequency Stability / Temperature Variation	12
4. TEST EQUIPMENT CALIBRATION DATE	13
5. SAMPLE CALCULATIONS	14
6. MEASUREMENT UNCERTAINTY	15
7. TEST RESULT	16
7.1. Summary	16
7.2. Occupied Bandwidth	17
7.2.1. Test Limit	17
7.2.2. Test Procedure used	17
7.2.3. Test Setting	17
7.2.4. Test Setup	17
7.2.5. Test Result	18
7.3. Spurious and Harmonic Emissions at Antenna Terminal	24

7.3.1. Test Limit	24
7.3.2. Test Procedure Used	24
7.3.3. Test Setting.....	24
7.3.4. Test Setup.....	24
7.3.5. Test Result.....	25
7.4. Conducted & Radiated Power and Radiated Spurious Emissions.....	37
7.4.1. Test Limit	37
7.4.2. Test Procedure Used	37
7.4.3. Test Setting.....	37
7.4.4. Test Setup.....	39
7.4.5. Test Result.....	40
7.5. Peak-Average Ratio.....	53
7.5.1. Test Limit	53
7.5.2. Test Procedure	53
7.5.3. Test Setup.....	53
7.5.4. Test Result.....	54
7.6. Frequency Stability Under Temperature & Voltage Variations.....	57
7.6.1. Test Limit	57
7.6.2. Test Procedure	57
7.6.3. Test Setup.....	57
7.6.4. Test Result.....	58
8. CONCLUSION.....	64

§2.1033 General Information

Applicant:	Shenzhen Inrico Electronics Co., Ltd
Applicant Address:	4/F, Building NO.108, High Tech Industrial Park, Guowei Road 72, Luohu District, Shenzhen, China
Manufacturer:	Shenzhen Inrico Electronics Co., Ltd
Manufacturer Address:	4/F, Building NO.108, High Tech Industrial Park, Guowei Road 72, Luohu District, Shenzhen, China
Test Site:	MRT Technology (Suzhou) Co., Ltd
Test Site Address:	D8 Building, Youxin Industrial Park, No.2 Tian'edang Rd., Wuzhong Economic Development Zone, Suzhou, China
MRT Registration No.:	809388
FCC Rule Part(s):	Part2, Part22 Subpart H, Part24 Subpart E
Model No.:	T196
FCC ID:	2AIV6-T196
Test Device Serial No.:	N/A <input type="checkbox"/> Production <input checked="" type="checkbox"/> Pre-Production <input type="checkbox"/> Engineering
FCC Classification:	PCS Licensed Transmitter Held to Face (PCF)

Test Facility / Accreditations

Measurements were performed at MRT Laboratory located in Tian'edang Rd., Suzhou, China.

- MRT facility is a FCC registered (MRT Reg. No. 809388) test facility with the site description report on file and has met all the requirements specified in Section 2.948 of the FCC Rules.
- MRT facility is an IC registered (MRT Reg. No. 11384A-1) test laboratory with the site description on file at Industry Canada.
- MRT facility is a VCCI registered (R-4179, G-814, C-4664, T-2206) test laboratory with the site description on file at VCCI Council.
- MRT Lab is accredited to ISO 17025 by the American Association for Laboratory Accreditation (A2LA) under the American Association for Laboratory Accreditation Program (A2LA Cert. No. 3628.01) in EMC, Telecommunications and Radio testing for FCC, Industry Canada, EU and TELEC Rules.



1. INTRODUCTION

1.1. Scope

Measurement and determination of electromagnetic emissions (EMC) of radio frequency devices including intentional and/or unintentional radiators for compliance with the technical rules and regulations of the Federal Communications Commission and the Industry Canada Certification and Engineering Bureau.

1.2. MRT Test Location

The map below shows the location of the MRT LABORATORY, its proximity to the Taihu Lake. These measurement tests were conducted at the MRT Technology (Suzhou) Co., Ltd. Facility located at D8 Building, Youxin Industrial Park, No.2 Tian'edang Rd., Wuzhong Economic Development Zone, Suzhou, China. The detailed description of the measurement facility was found to be in compliance with the requirements of § 2.948 according to ANSI C63.4-2009 on September 30, 2013.



2. PRODUCT INFORMATION

2.1. Equipment Description

Product Name	Smart Phone
Model No.	T196
Operational Band	GPRS/EDGE 850 / 1900, WCDMA Band II / V
Tx Frequency	GPRS/EDGE: 850: 824.2MHz ~ 848.8MHz 1900: 1850.2MHz ~ 1909.8MHz WCDMA: Band V: 826.4MHz ~ 846.6MHz Band II: 1852.4MHz ~ 1907.6MHz
Rx Frequency	GPRS/EDGE: 850: 869.2MHz ~ 893.8MHz 1900: 1930.2MHz ~ 1989.8MHz WCDMA: Band V: 871.4MHz ~ 891.6MHz Band II: 1932.4MHz ~ 1987.6MHz
Maximum Output Power to Antenna	GPRS 850: 31.93dBm GPRS 1900: 28.74dBm WCDMA Band II: 24.13dBm WCDMA Band V: 25.28dBm
Antenna Type	Detachable Dipole Antenna
Antenna Gain	GPRS 850: 2.15dBi GPRS 1900: 2.15dBi WCDMA Band II: 2.15dBi WCDMA Band V: 2.15dBi
Type of Modulation	GPRS: GMSK; EDGE: 8PSK WCDMA/HSDPA/HSUPA: QPSK (Uplink)

Note: The test data contained in this report only to the emissions due to the EUT's 2G/3G licensed transmitters. The test report has showed the worst test mode.

2.2. Device Capabilities

This device contains the following capabilities:

850 / 1900 GPRS / EDGE, 850 / 1900 WCDMA / HSDPA / HSUPA.

2.3. Test Configuration

The **Smart Phone** was tested per the guidance of ANSI/TIA-603-D-2010 and KDB 971168 D01v02r02. See section 3.0 of this report for a description of the radiated and antenna port conducted emissions tests.

2.4. EMI Suppression Device(s)/Modifications

No EMI suppression device(s) were added and no modifications were made during testing.

3. DESCRIPTION OF TEST

3.1. Evaluation Procedure

The measurement procedures described in the “Land Mobile FM or PM – Communications Equipment – Measurements and Performance Standards” (ANSI/TIA-603-D-2010) and “Procedures for Compliance Measurement of the Fundamental Emission Power of Licensed Wideband (> 1 MHz) Digital Transmission Systems” (KDB 971168) were used in the measurement of the **Smart Phone**.

Deviation from measurement procedure.....None

3.2. Cellular – Base Frequency Blocks

§22.905

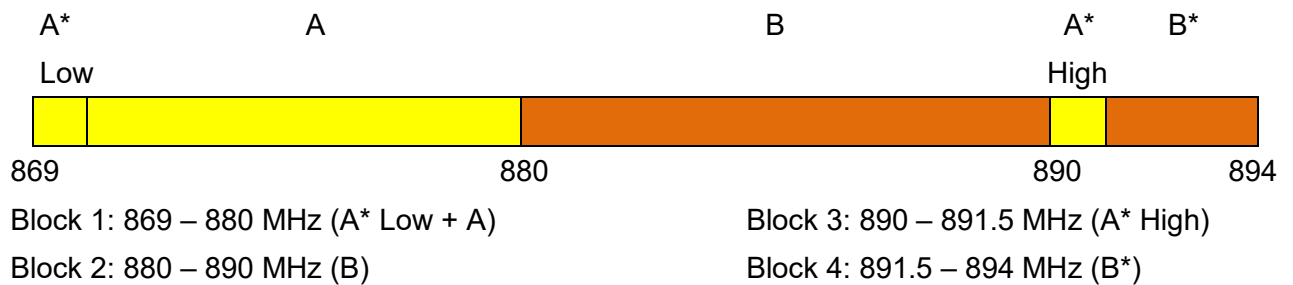

3.3. Cellular – Mobile Frequency Blocks

§22.905

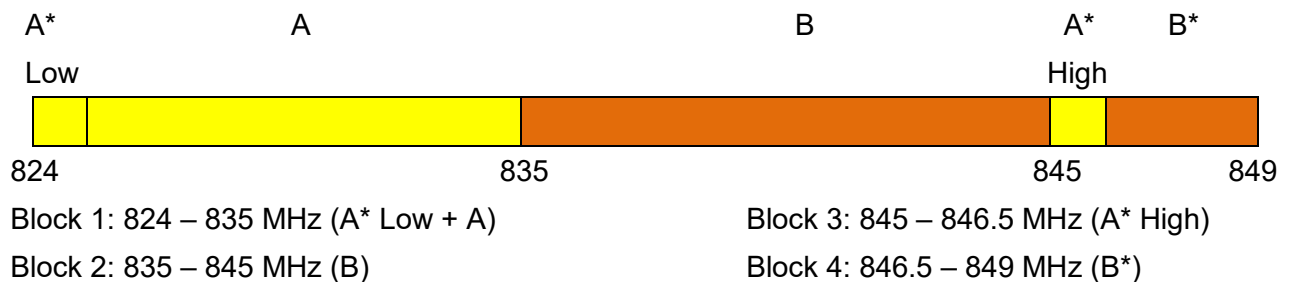

3.4. PCS – Base Frequency Blocks

§24.229

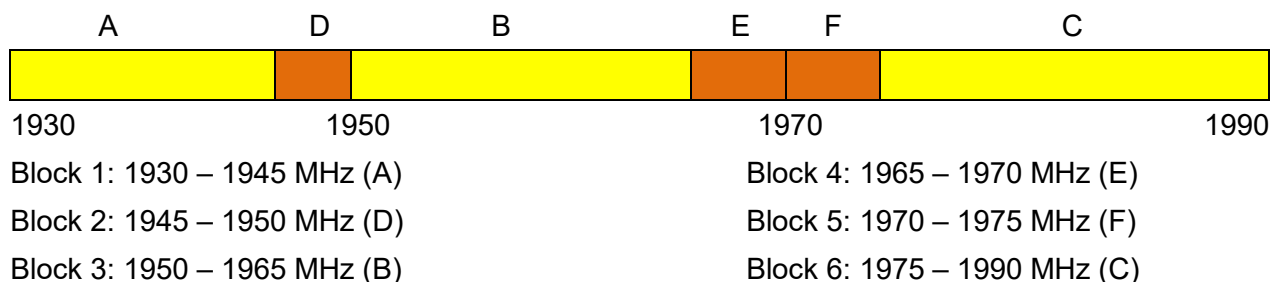

3.5. PCS – Mobile Frequency Blocks

§24.229

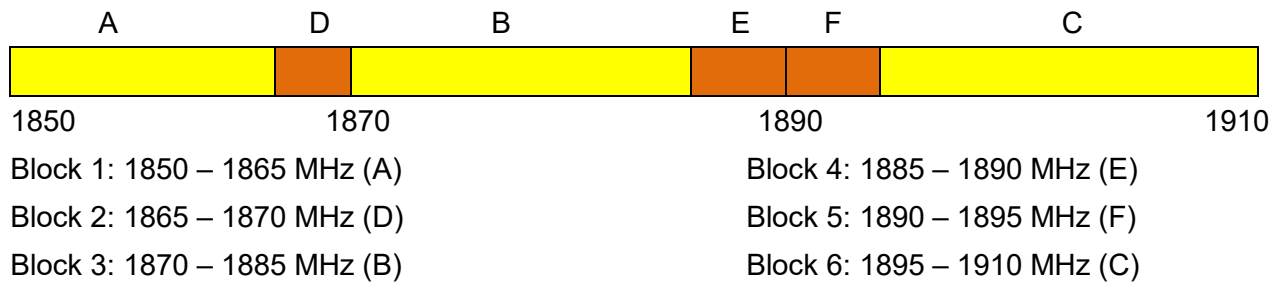

3.6. Occupied Bandwidth

§2.1049

The occupied bandwidth, that is the frequency bandwidth such that, below its lower and above its upper frequency limits, the mean powers radiated are each equal to 0.5 percent of the total mean power radiated by a given emission shall be measured. The spectrum analyzers’ “occupied bandwidth” measurement function was used to record the occupied bandwidth in accordance with KDB 971168.

3.7. Spurious and Harmonic Emissions at Antenna Terminal

§2.1051 §22.917(a) §24.238(a)

The level of the carrier and the various conducted spurious and harmonic frequencies is measured by means of a calibrated spectrum analyzer. The spectrum is scanned from the lowest frequency generated in the equipment up to a frequency including its 10th harmonic. On any frequency outside a licensee’s frequency block, the power of any emission shall be attenuated below the transmitter power (P) by at least 43 + 10 log(P) dB. Compliance with these provisions is based on the use of measurement instrumentation employing a resolution bandwidth of 100 kHz or greater for Part 22 and 1 MHz or greater for Part 24. However, in the 1 MHz bands immediately outside and adjacent to the frequency block a resolution bandwidth of at least one percent of the emission bandwidth of the fundamental emission of the transmitter may be employed. The emission bandwidth is defined as the width of the signal between two points, one below the carrier center frequency and one above the carrier center frequency, outside of which all emission are attenuated at least 26 dB below the transmitter power.

3.8. Radiated Power and Radiated Spurious Emissions

§2.1053 §22.913(a.2) §22.917(a) §24.232(c) §24.238(a)

The radiated test facilities consisted of an indoor 3 meter semi-anechoic chamber used for final measurement and exploratory measurements, when necessary. The measurement area is contained within the semi-anechoic chamber which is shielded from any ambient interference. For measurements above 1GHz absorbers are arranged on the floor between the turn table and the antenna mast in such a way so as to maximize the reduction of reflections. For measurements below 1GHz, the absorbers are removed. A MF Model 210SS turntable is used for radiated measurement. It is a continuously rotatable, remote-controlled, metallic turntable and 2 meters (6.56 ft.) in diameter. The turn table is flush with the raised floor of the chamber in order to maintain its function as a ground plane. A 80cm high PVC support structure is placed on top of the turntable.

The equipment under test was transmitting while connected to its integral antenna and is placed on a wooden turntable 80cm above the ground plane and 3 meters from the receive antenna. The receive antenna height is adjusted between 1 and 4 meter height, the turntable is rotated through 360 degrees, and the EUT is manipulated through all orthogonal planes representative of its typical use to achieve the highest reading on the receive spectrum analyzer. Radiated power levels are also investigated with the receive antenna horizontally and vertically polarized. The maximized power level is recorded using the spectrum analyzer "Channel Power" function with the integration band set to the emissions' occupied bandwidth, a RMS detector, RBW = 100kHz, VBW = 300kHz, and a 1 second sweep time over a minimum of 10 sweeps, per the guidelines of KDB 971168.

Per the guidance of ANSI/TIA-603-D-2010, a half-wave dipole is then substituted in place of the EUT. For emissions above 1GHz, a horn antenna is substituted in place of the EUT. The substitute antenna is driven by a signal generator with the level of the signal generator being adjusted to obtain the same receive spectrum analyzer level previously recorded from the spurious emission from the EUT. The power of the emission is calculated using the following formula:

$$P_d \text{ [dBm]} = P_g \text{ [dBm]} - \text{cable loss [dB]} + \text{antenna gain [dBd/dBi]}$$

Where, P_d is the dipole equivalent power, P_g is the generator output into the substitution antenna, and the antenna gain is the gain of the substitute antenna used relative to either a half-wave dipole (dBd) or an isotropic source (dBi). The substitute level is equal to $P_g \text{ [dBm]} - \text{cable loss [dB]}$.

The calculated P_d levels are then compared to the absolute spurious emission limit of -13dBm which is equivalent to the required minimum attenuation of $43 + 10 \cdot \log_{10}(\text{Power [Watts]})$ specified in 22.917(a) and 24.238(a).

3.9. Peak-Average Ratio

§24.232(d)

A peak to average ratio measurement is performed at the conducted port of the EUT. The spectrum analyzers Complementary Cumulative Distribution Function (CCDF) measurement profile is used to determine the largest deviation between the average and the peak power of the EUT in a given bandwidth. The CCDF curve shows how much time the peak waveform spends at or above a given average power level. The percent of time the signal spends at or above the level defines the probability for that particular power level.

For pulsed signals, the spectrum analyzer is set to use an internal “RF Burst” trigger that is synced with an incoming pulse and the measurement interval is set to less than the duration of the “on time” of one burst to ensure that energy is only captured during a time in which the transmitter is operating at maximum power. For continuous signals, the trigger is set to “free run” in the CCDF measurement mode.

3.10. Frequency Stability / Temperature Variation

§2.1055 §22.355 §22.863 §22.905 §24.229 §24.235

Frequency stability testing is performed in accordance with the guidelines of ANSI/TIA-603-D-2010. The frequency stability of the transmitter is measured by:

- a.) Temperature: The temperature is varied from -30°C to +50°C in 10°C increments using an environmental chamber.
- b.) Primary Supply Voltage: The primary supply voltage is varied from 85% to 115% of the nominal value for non hand-carried battery and AC powered equipment. For hand-carried, battery-powered equipment, primary supply voltage is reduced to the battery operating end point which shall be specified by the manufacturer.

Specification – For Part 22, the frequency stability of the transmitter shall be maintained within $\pm 0.00025\%$ (± 2.5 ppm) of the center frequency. For Part 24, the frequency stability shall be sufficient to ensure that the fundamental emission stays within the authorized frequency block.

Time Period and Procedure:

1. The carrier frequency of the transmitter is measured at room temperature (20°C to provide a reference).
2. The equipment is turned on in a “standby” condition for fifteen minutes before applying power to the transmitter. Measurement of the carrier frequency of the transmitter is made within one minute after applying power to the transmitter.
3. Frequency measurements are made at 10°C intervals ranging from -30°C to +50°C. A period of at least one half-hour is provided to allow stabilization of the equipment at each temperature level.

4. TEST EQUIPMENT CALIBRATION DATE

Radiated Emission - AC1

Instrument	Manufacturer	Type No.	Asset No.	Cali. Interval	Cali. Due Date
MXE EMI Receiver	Agilent	N9038A	MRTSUE06125	1 year	2017/08/03
Radio Communication Tester	R&S	CMU 200	MRTSUE06009	1 year	2017/11/10
Preamplifier	Agilent	83017A	MRTSUE06076	1 year	2018/03/28
Loop Antenna	Schwarzbeck	FMZB1519	MRTSUE06025	1 year	2017/12/14
TRILOG Antenna	Schwarzbeck	VULB9168	MRTSUE06172	1 year	2017/11/19
Broad-Band Horn Antenna	Schwarzbeck	BBHA9120D	MRTSUE06023	1 year	2017/10/22
Broadband Horn Antenna	Schwarzbeck	BBHA9170	MRTSUE06024	1 year	2018/01/04
Temperature/Humidity Meter	Yuhuaze	HTC-2	MRTSUE06183	1 year	2017/12/20
Anechoic Chamber	TDK	Chamber-AC1	MRTSUE06212	1 year	2018/05/10

Conducted Test Equipment - TR3

Instrument	Manufacturer	Type No.	Asset No.	Cali. Interval	Cali. Due Date
Spectrum Analyzer	Agilent	N9020A	MRTSUE06106	1 year	2018/05/08
Radio Communication Tester	R&S	CMU 200	MRTSUE06009	1 year	2017/11/10
USB Wideband Power Sensor	Boonton	55006	MRTSUE06109	1 year	2018/05/08
Programmable Temperature & Humidity Chamber	BAOYT	BYH-1500L	MRTSUE06051	1 year	2017/12/06
Temperature/Humidity Meter	Yuhuaze	HTC-2	MRTSUE06180	1 year	2017/12/22

Software	Version	Function
e3	V8.3.5	EMI Test Software

5. SAMPLE CALCULATIONS

GSM Emission Designator

Emission Designator = 250KGXW

GPRS BW = 250 kHz

G = Phase Modulation

X = Cases not otherwise covered

W = Combination (Audio/Data)

EDGE Emission Designator

Emission Designator = 250KG7W

GPRS BW = 250 kHz

G = Phase Modulation

7 = Quantized/Digital Info

W = Combination (Audio/Data)

WCDMA Emission Designator

Emission Designator = 4M16F9W

WCDMA BW = 4.16 MHz

F = Frequency Modulation

9 = Composite Digital Info

W = Combination (Audio/Data) (Measured at the 99.75% power bandwidth)

Spurious Radiated Emission

Example: Spurious emission at 3700.40 MHz

The receive spectrum analyzer reading at 3 meters with the EUT on the turntable was -81.0dBm .

The gain of the substituted antenna is 8.1dBi . The signal generator connected to the substituted antenna terminals is adjusted to produce a reading of -81.0dBm on the spectrum analyzer. The loss of the cable between the signal generator and the terminals of the substituted antenna is 2.0dB at 3700.40MHz . So 6.1dB is added to the signal generator reading of -30.9dBm yielding -24.80dBm . The fundamental EIRP was 25.50dBm so this harmonic was $25.50\text{dBm} - (-24.80) = 50.3\text{dBc}$.

6. MEASUREMENT UNCERTAINTY

Where relevant, the following test uncertainty levels have been estimated for tests performed on the EUT as specified in CISPR 16-4-2. This uncertainty represents an expanded uncertainty expressed at approximately the 95% confidence level using a coverage factor of $k = 2$.

Radiated Emission Measurement - AC1

Measuring Uncertainty for a Level of Confidence of 95% ($U=2Uc(y)$):

9kHz ~ 1GHz: $\pm 4.18\text{dB}$

1GHz ~ 40GHz: $\pm 4.76\text{dB}$

7. TEST RESULT

7.1. Summary

Company Name: Shenzhen Inrico Electronics Co., Ltd
FCC ID: 2AIV6-T196
FCC Classification: PCS Licensed Transmitter Held to Face (PCF)
Mode(s): GPRS / EDGE / WCDMA

FCC Part Section(s)	Test Description	Test Limit	Test Condition	Test Result	Reference
<u>Transmitter Mode(TX)</u>					
2.1049	Occupied bandwidth	N/A	Conducted	Pass	Section 7.2
2.1051 22.917(a) 24.238(a)	Band Edge / Conducted Spurious Emissions	> 43 + log ₁₀ (P[Watts]) at Band Edge and for all out-of-band emissions		Pass	Section 7.3
24.232(d)	Peak-Average Ratio	< 13 dB		Pass	Section 7.5
2.1046	Transmitter Conducted Output Power	N/A		Pass	Section 7.4
22.913(a.2)	Effective Radiated Power	< 7 Watts max. ERP	Radiated	Pass	Section 7.4
24.232(c)	Equivalent Isotropic Radiated Power	< 2 Watts max. EIRP		Pass	Section 7.4
2.1053 22.917(a) 24.238(a)	Undesirable Emissions	> 43 + log ₁₀ (P[Watts]) for all out-of-band emissions		Pass	Section 7.4
2.1055 22.355 24.235	Frequency Stability	< 2.5 ppm (Part 22) Emission must remain in band (Part 24)		Pass	Section 7.6

Notes:

- 1) All modes of operation and data rates were investigated. The test results shown in the following sections represent the worst case emissions.
- 2) The analyzer plots shown in Section 4.0 were all taken with a correction table loaded into the analyzer. The correction table was used to account for the losses of the cables, directional couplers, and attenuators used as part of the system to maintain a link between the call box and the EUT at all frequencies of interest.
- 3) All antenna port conducted emissions testing was performed on a test bench with the antenna port of the EUT connected to the spectrum analyzer through calibrated cables, attenuators, and couplers.

7.2. Occupied Bandwidth

7.2.1. Test Limit

N/A

7.2.2. Test Procedure used

KDB 971168 D01v02r02 – Section 4.1 & ANSI/TIA-603-D-2010

7.2.3. Test Setting

1. The spectrum analyzer center frequency is set to the nominal EUT channel center frequency.
The span range for the spectrum analyzer shall be between two and five times the anticipated OBW. RBW = approximately 1% of the emission bandwidth.
2. The nominal resolution bandwidth (RBW) shall be in the range of 1 to 5 % of the anticipated OBW, and the VBW shall be at least 3 times the RBW.
3. Set the detection mode to peak, and the trace mode to max hold.
4. Use the 99 % power bandwidth function of the spectrum analyzer (if available) and report the measured bandwidth.

7.2.4. Test Setup

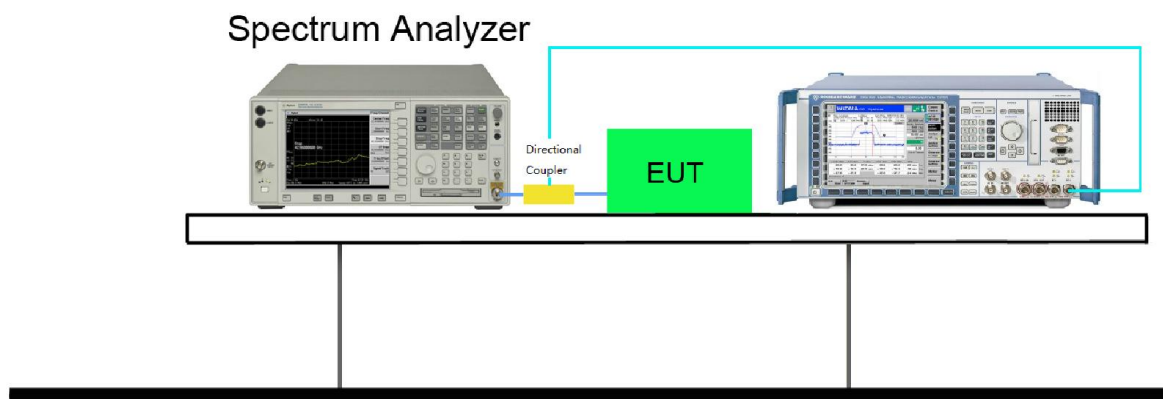

7.2.5. Test Result

Test Mode	Channel No.	Frequency (MHz)	99% Occupied Bandwidth (kHz)	-26dB Occupied Bandwidth (kHz)	Result
GPRS850	128	824.2	243.0	312.6	Pass
	189	836.4	244.1	319.1	Pass
	251	848.8	246.3	314.7	Pass
GPRS1900	512	1850.2	243.2	318.7	Pass
	661	1880.0	241.9	313.3	Pass
	810	1909.8	243.3	318.2	Pass
EDGE850	128	824.2	248.2	312.0	Pass
	189	836.4	250.0	309.8	Pass
	251	848.8	251.5	315.9	Pass
EDGE1900	512	1850.2	249.5	323.7	Pass
	661	1880.0	249.2	317.2	Pass
	810	1909.8	250.0	321.2	Pass
WCDMA Band II	9262	1852.4	4157.7	4651.0	Pass
	9400	1880.0	4152.4	4661.0	Pass
	9538	1907.6	4170.9	4678.0	Pass
WCDMA Band V	4132	826.4	4150.0	4649.0	Pass
	4182	836.4	4151.8	4641.0	Pass
	4233	846.6	4147.9	4646.0	Pass

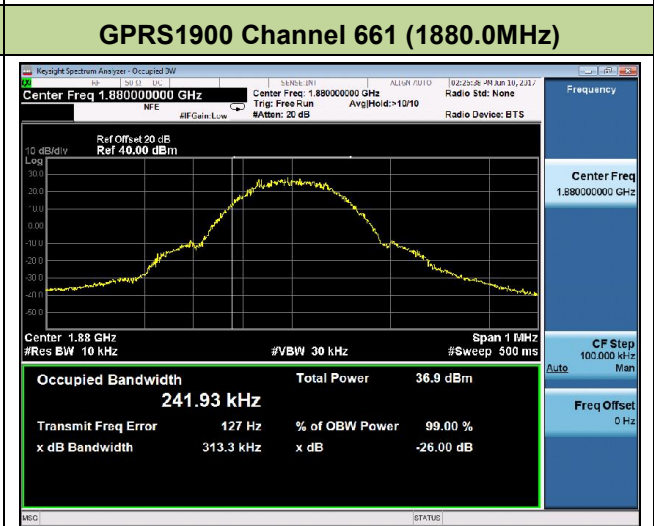
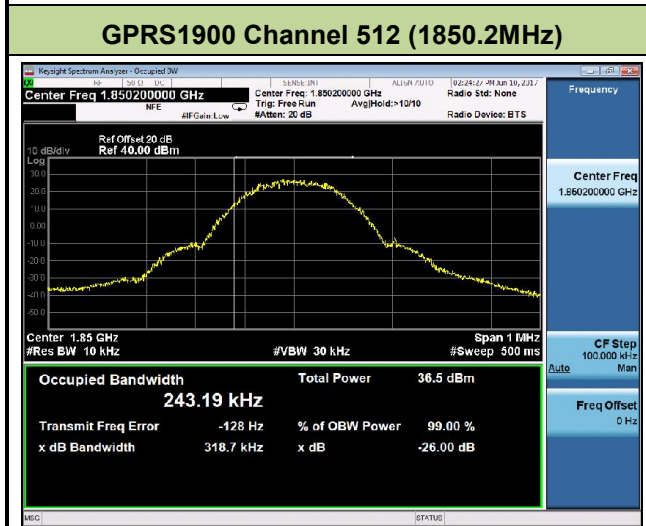
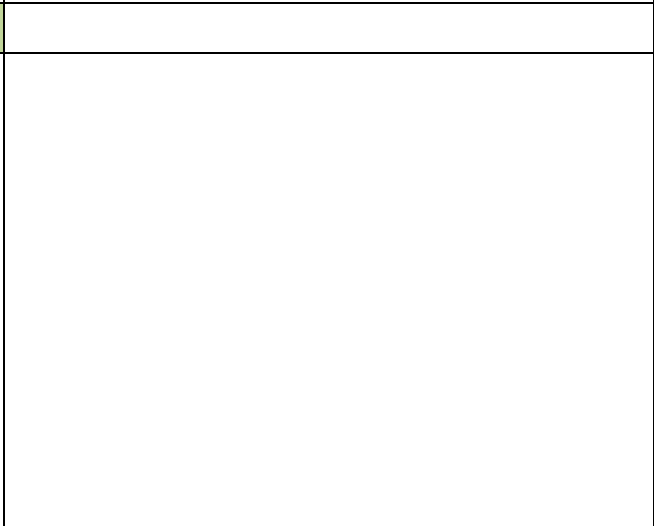
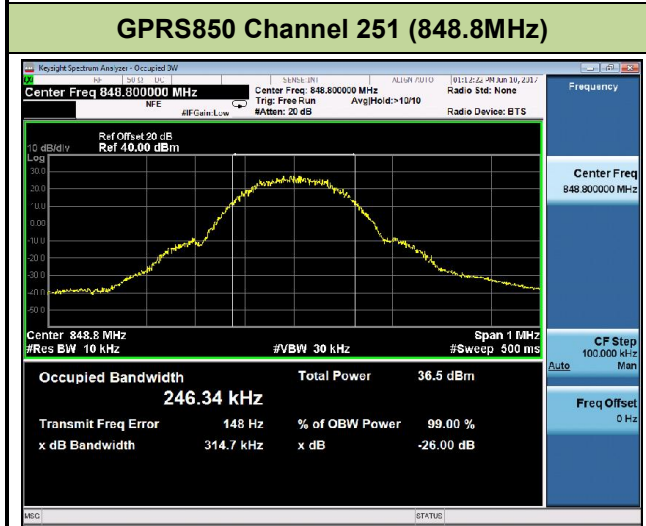
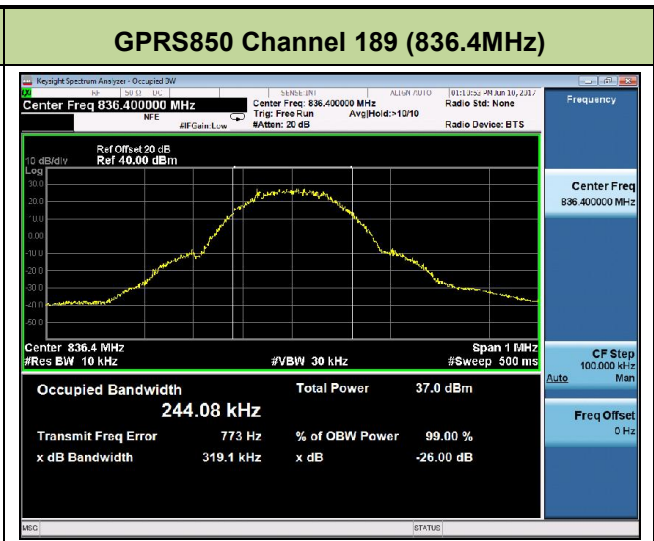
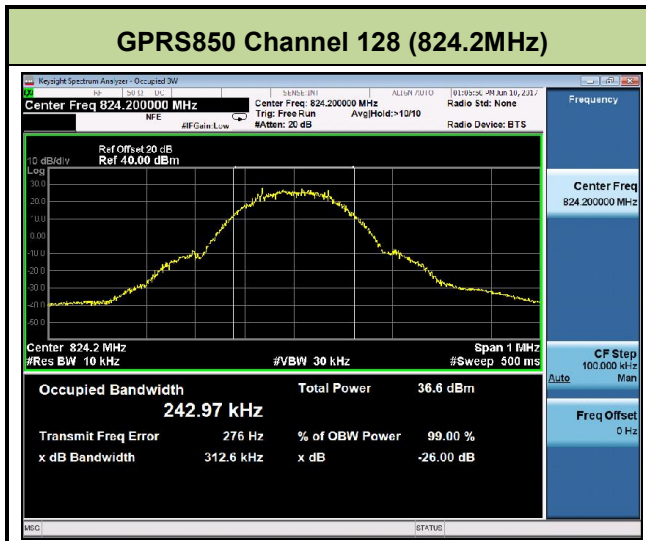

GPRS1900 Channel 810 (1909.8MHz)

EDGE850 Channel 128 (824.2MHz)

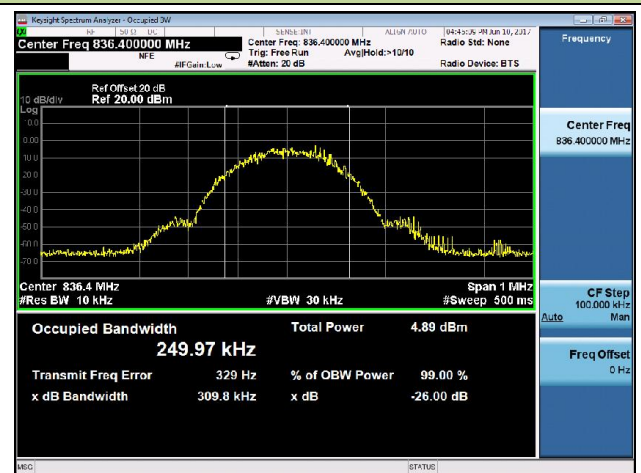
EDGE850 Channel 189 (836.4MHz)

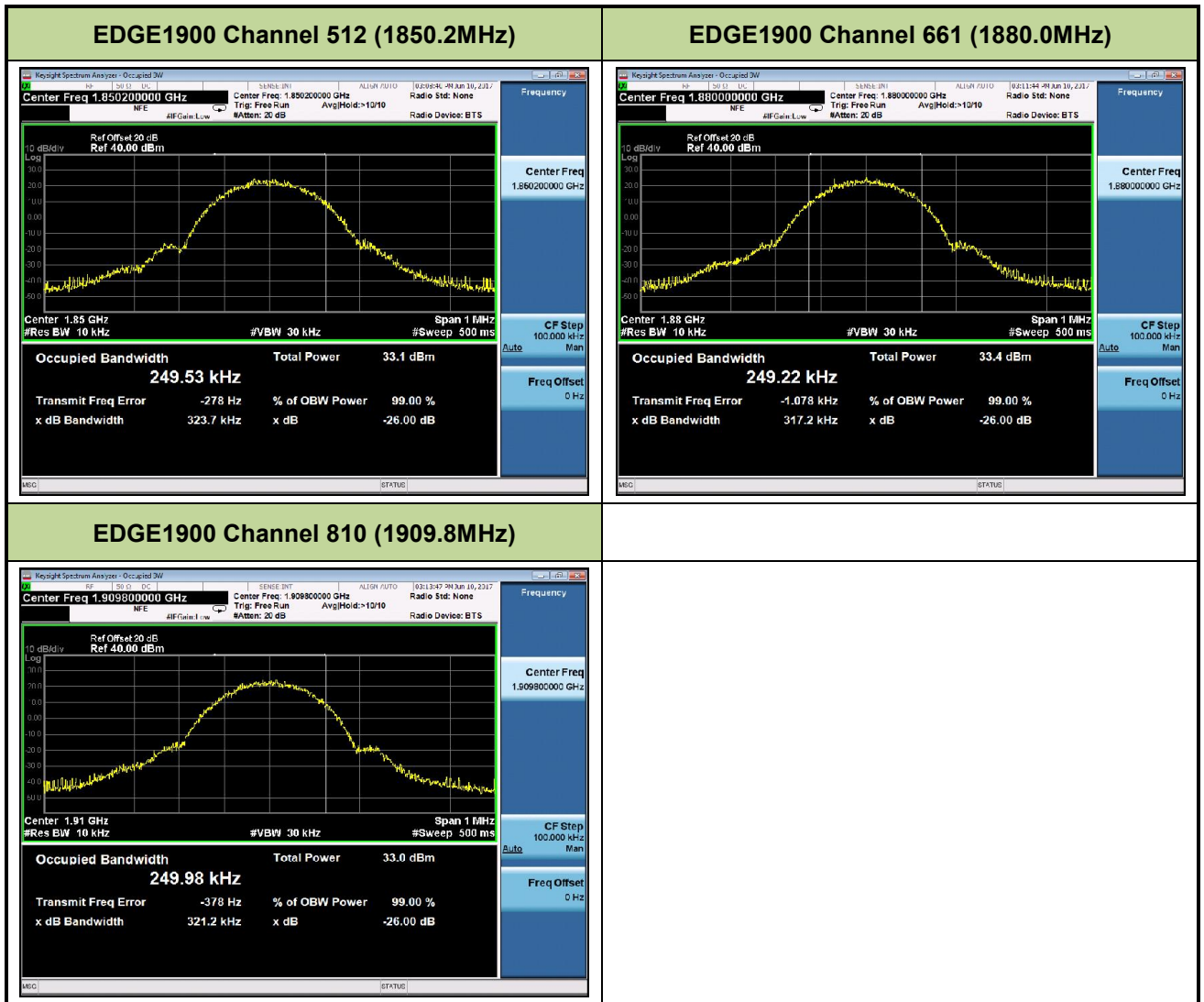
EDGE850 Channel 251 (848.8MHz)

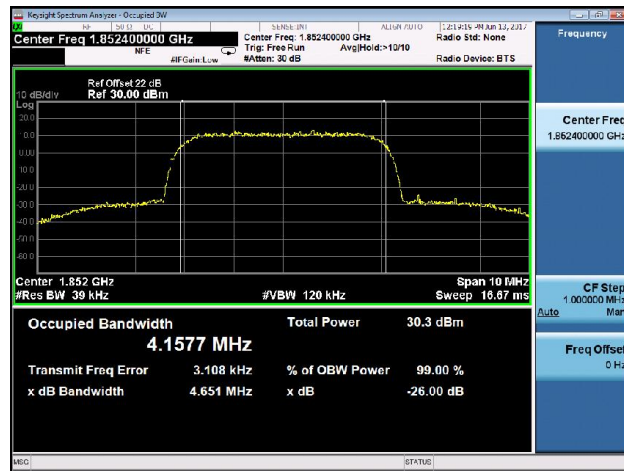
WCDMA Band II Channel 9262 (1852.4MHz)

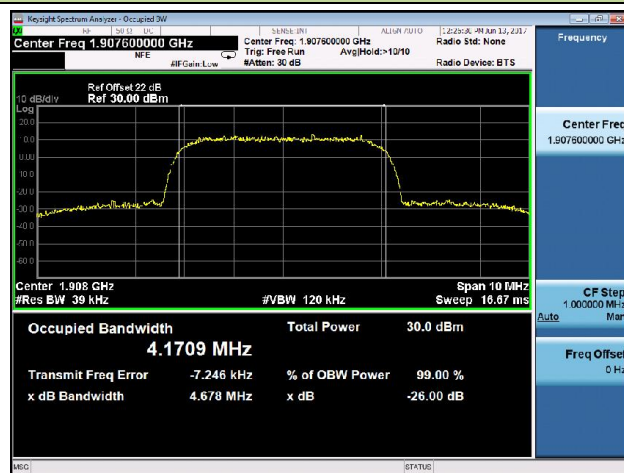
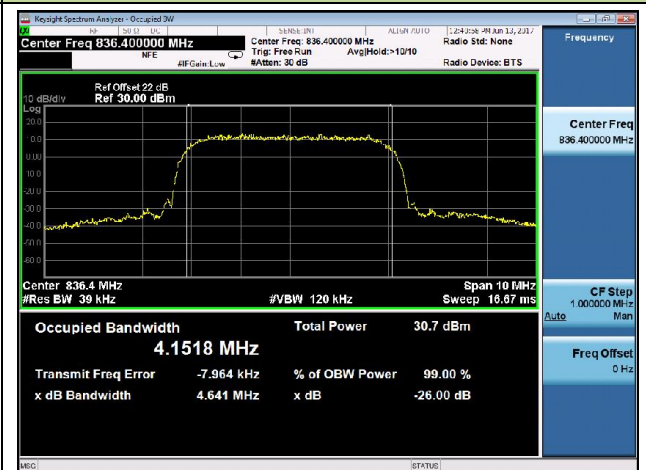
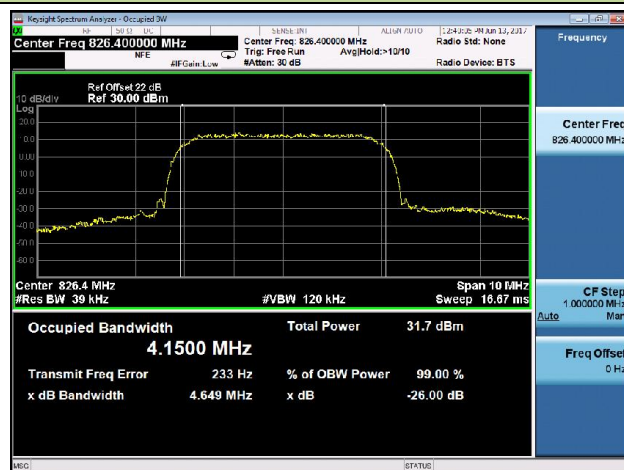
WCDMA Band II Channel 9400 (1880.0MHz)

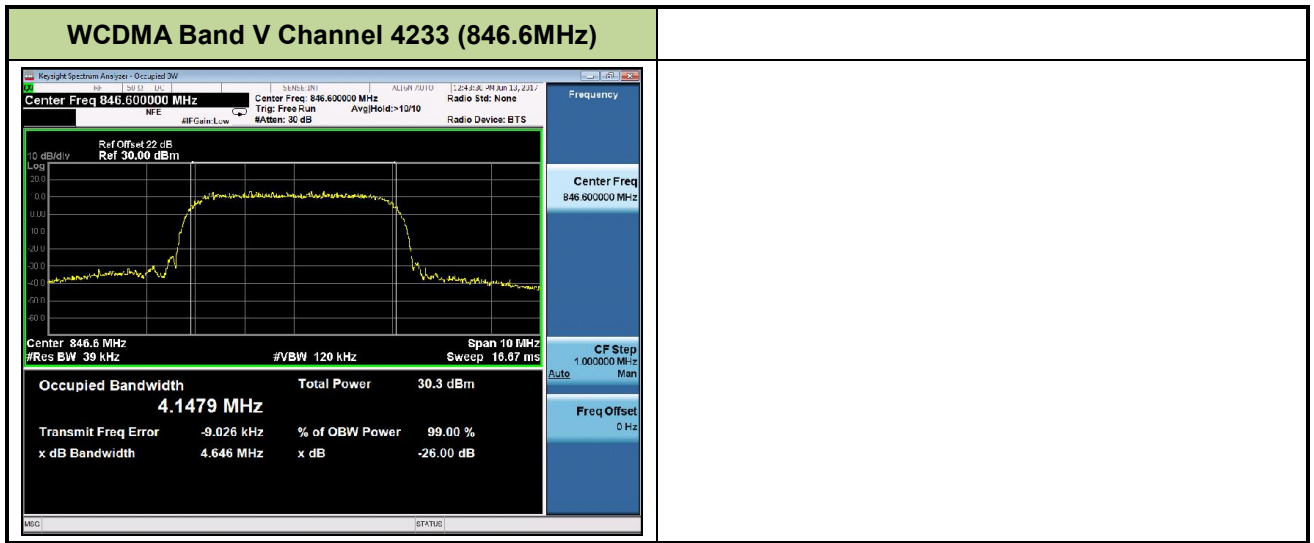
WCDMA Band II Channel 9538 (1907.6MHz)

WCDMA Band V Channel 4182 (836.4MHz)

WCDMA Band V Channel 4132 (826.4MHz)



7.3. Spurious and Harmonic Emissions at Antenna Terminal

7.3.1. Test Limit

The power of any emission outside of the authorized operating frequency ranges must be attenuated below the transmitting power (P) by a factor of at least $43 + 10\log(P)$ dB.

7.3.2. Test Procedure Used

KDB 971168 D01v02r02 – Section 6.0 & ANSI/TIA-603-D-2010

7.3.3. Test Setting

In the 1MHz bands immediately outside and adjacent to the frequency block a resolution bandwidth of at least one percent of the emission bandwidth of the fundamental emission of the transmitter may be employed to measure the out of band Emissions.

7.3.4. Test Setup

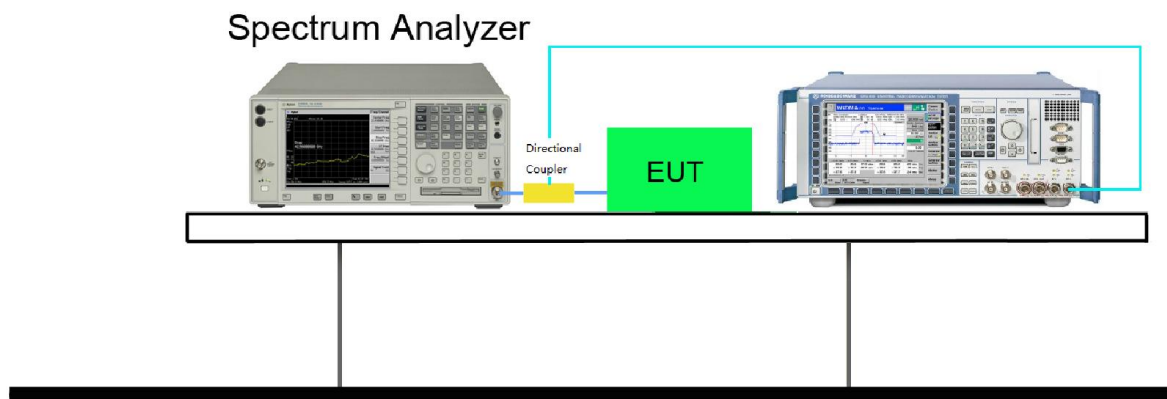

7.3.5. Test Result

Mode	Channel No.	Frequency (MHz)	Modulation	Test Result
GPRS850	128	824.2	GMSK	Pass
GPRS850	189	836.4	GMSK	Pass
GPRS850	251	848.8	GMSK	Pass

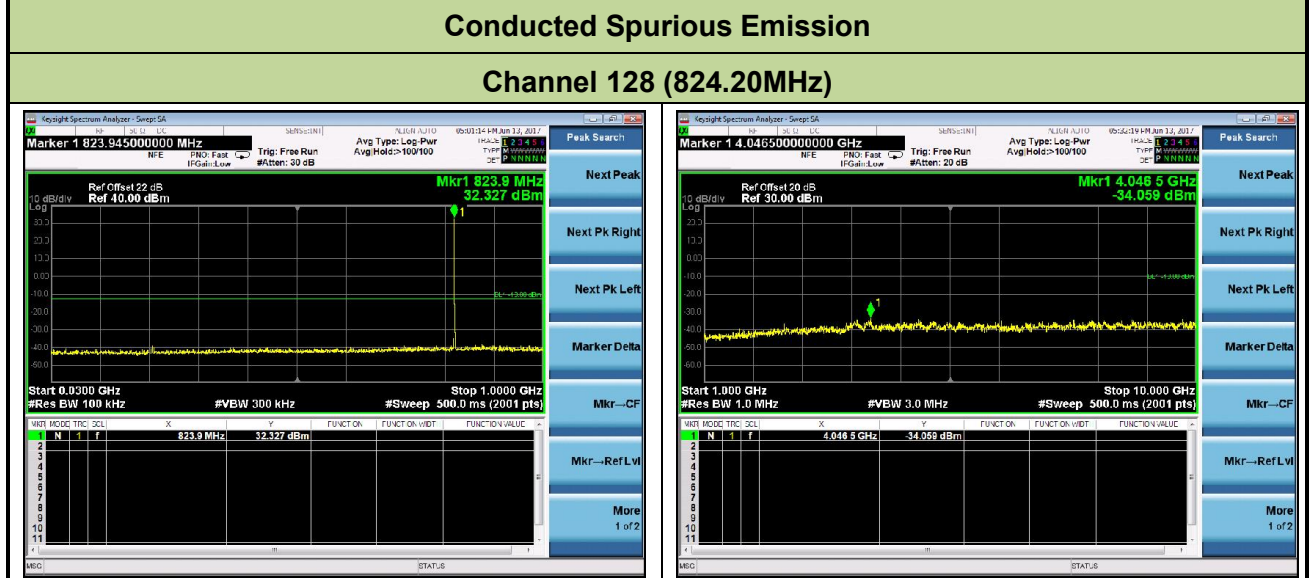
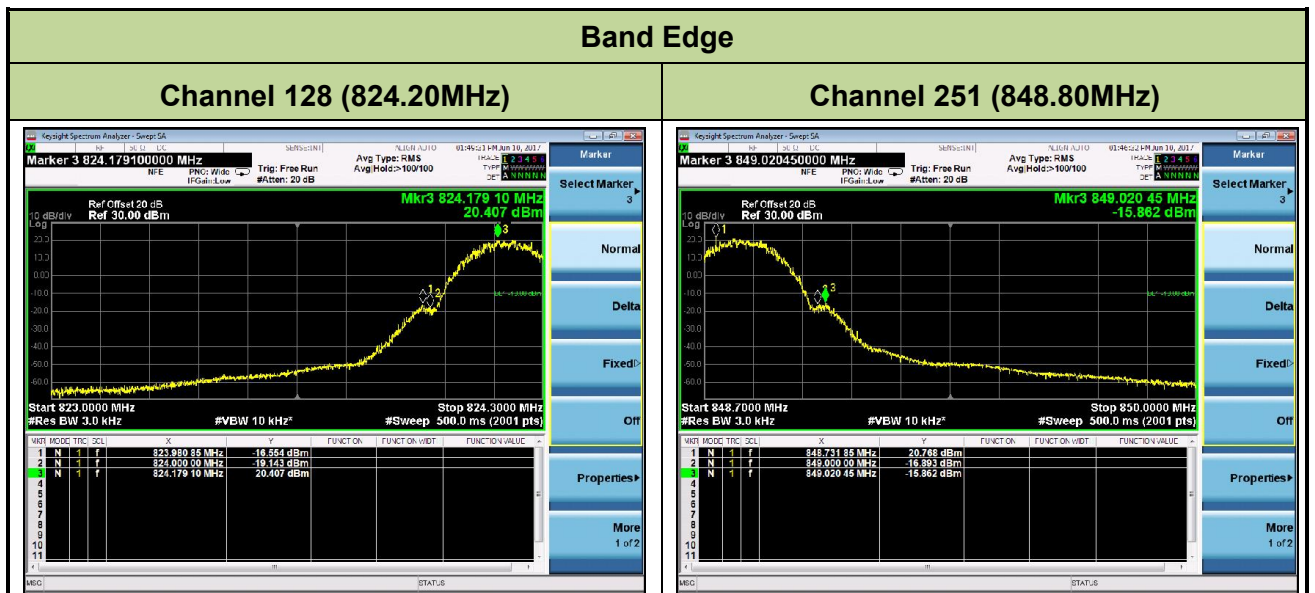

Channel 189 (836.40MHz)

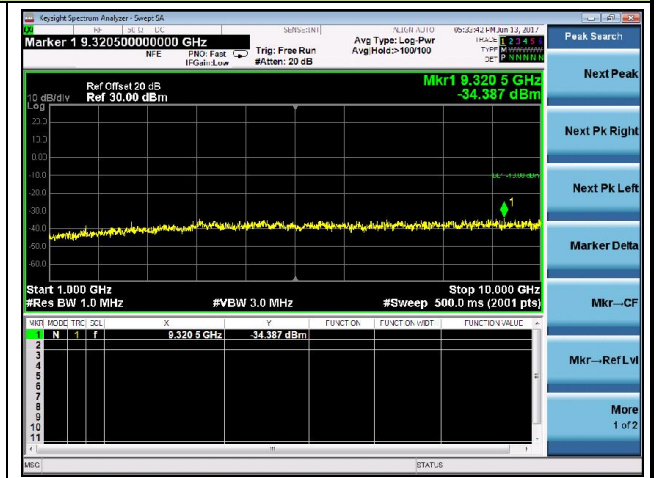
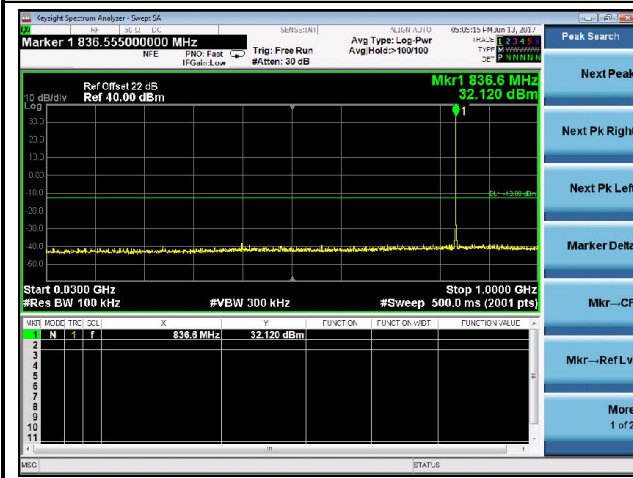

Channel 251 (848.80MHz)

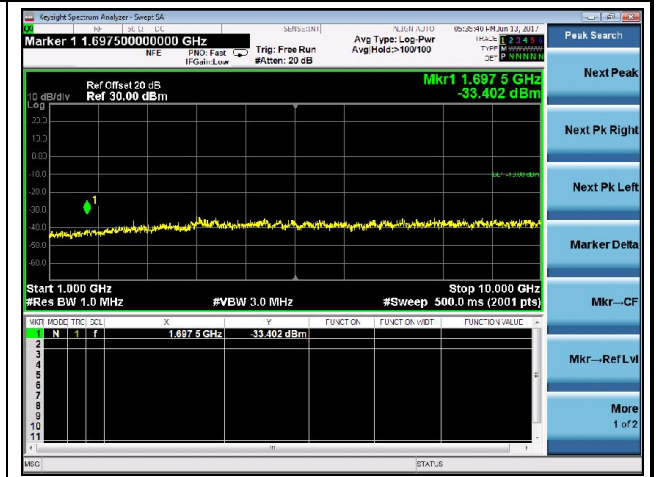
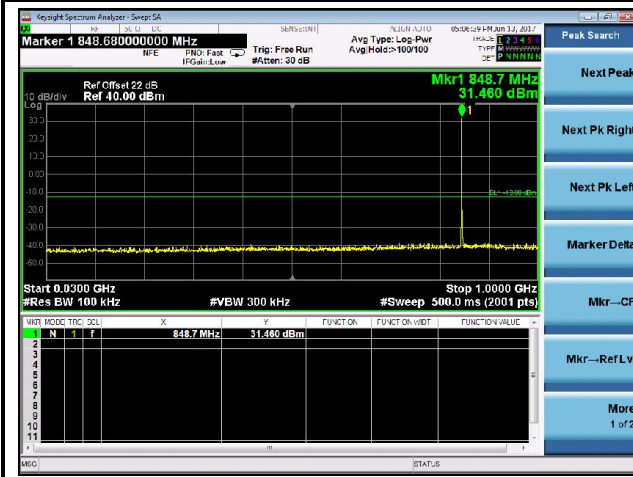

Mode	Channel No.	Frequency (MHz)	Modulation	Test Result
GPRS1900	512	1850.2	GMSK	Pass
GPRS1900	661	1880.0	GMSK	Pass
GPRS1900	810	1909.8	GMSK	Pass

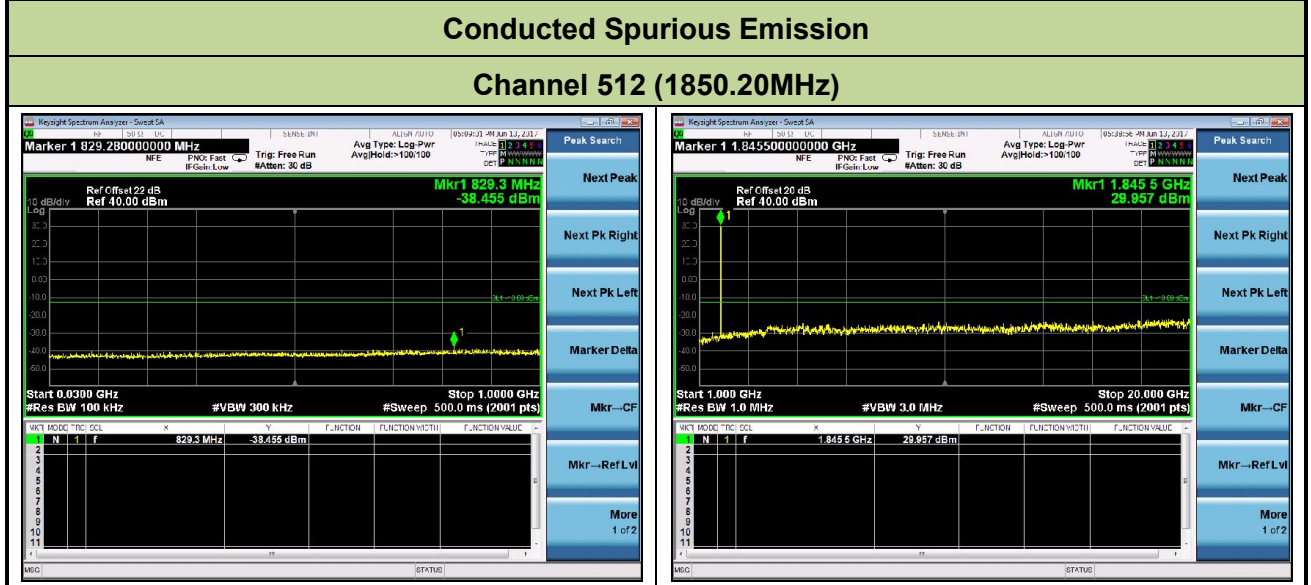
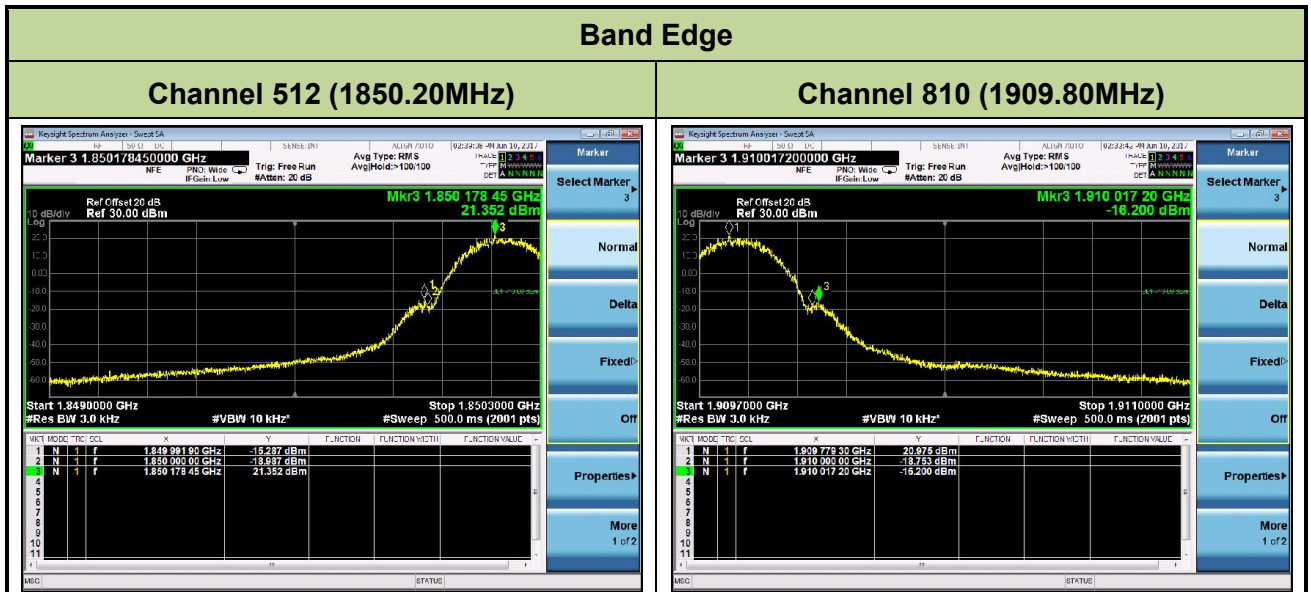

Channel 661 (1880.00MHz)

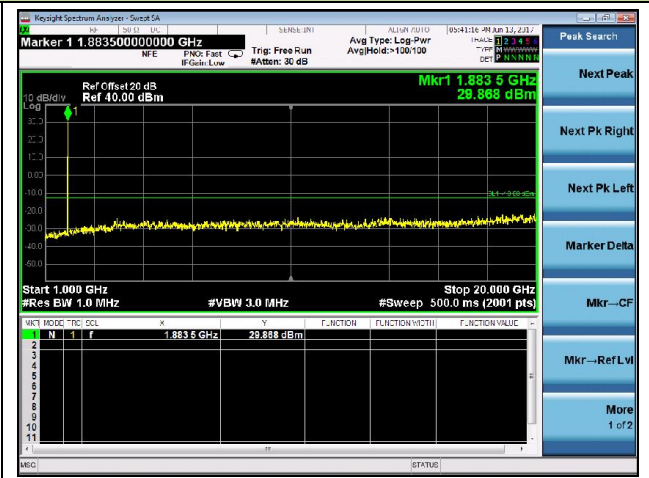
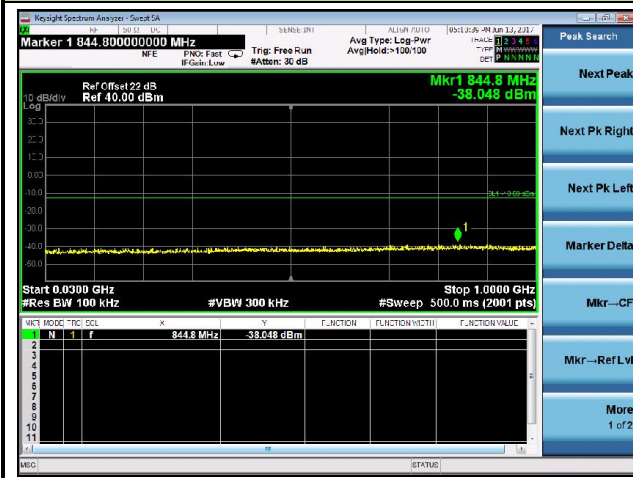

Channel 810 (1909.80MHz)

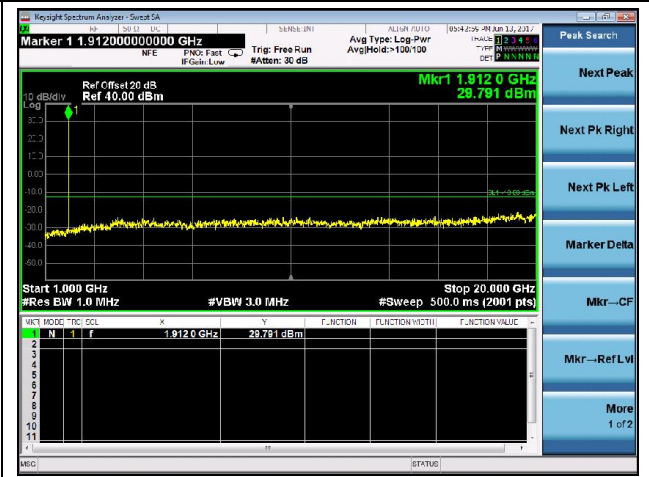
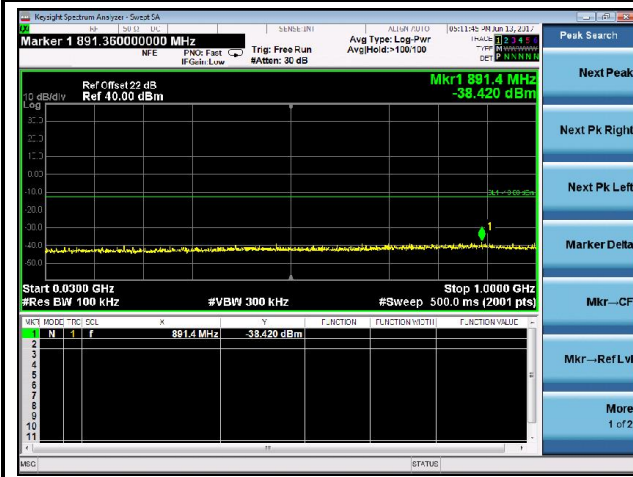

Mode	Channel No.	Frequency (MHz)	Modulation	Test Result
EDGE850	128	824.2	8PSK	Pass
EDGE850	189	836.4	8PSK	Pass
EDGE850	251	848.8	8PSK	Pass

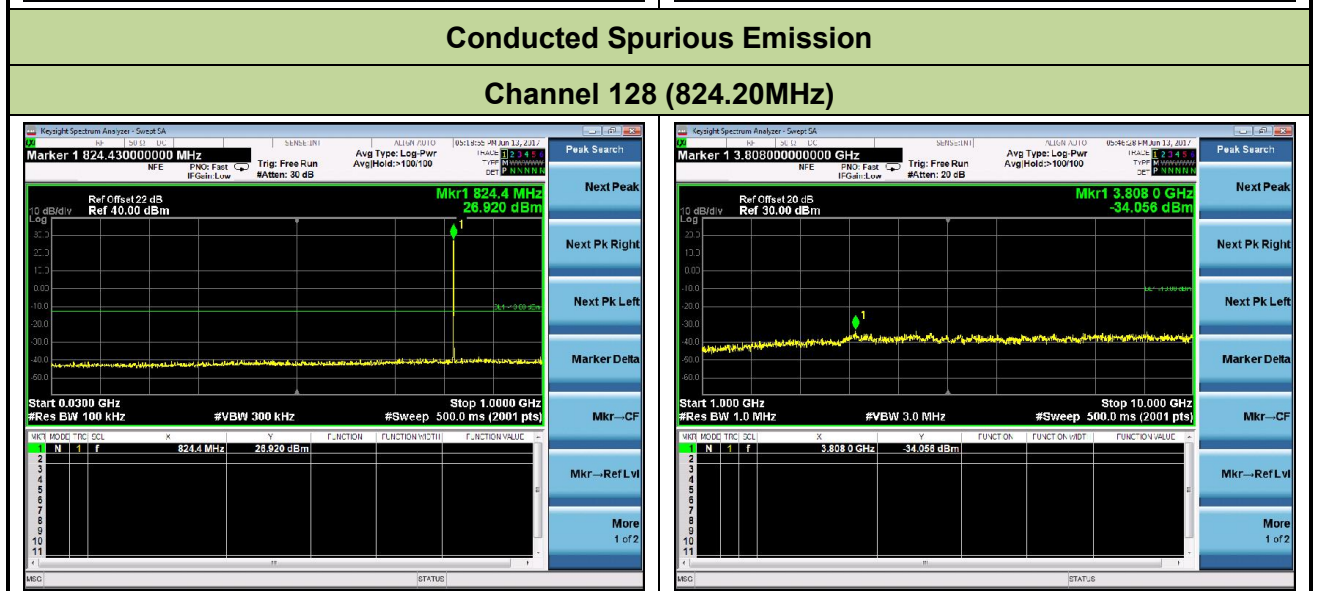
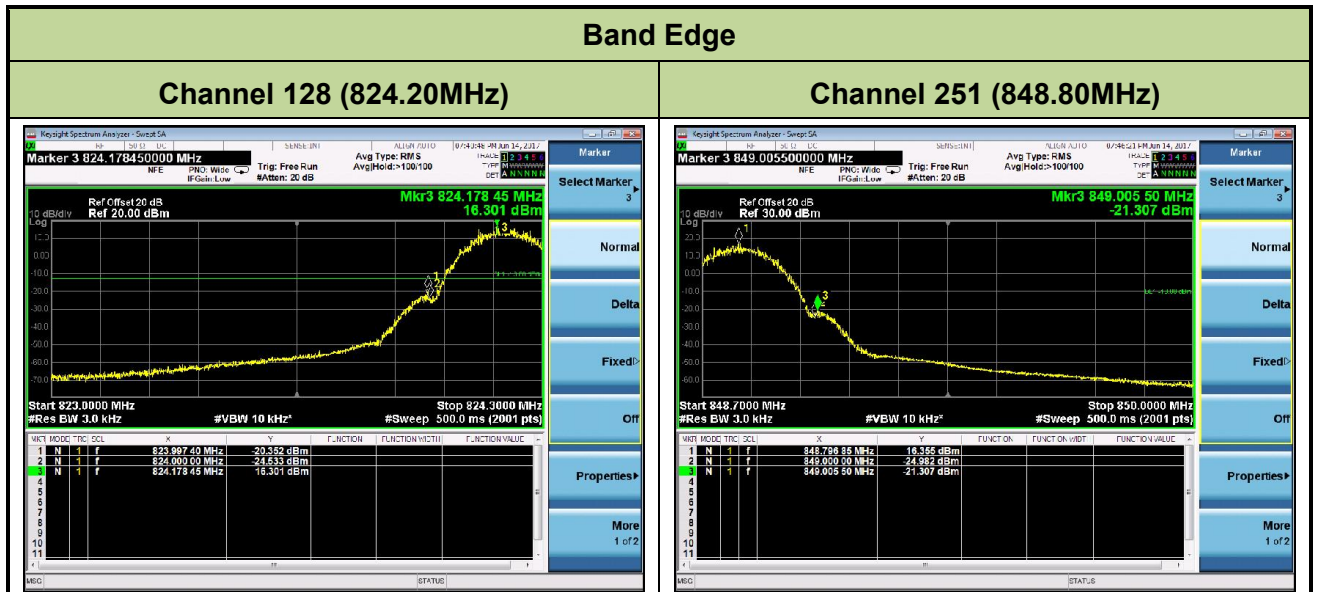

Channel 189 (836.40MHz)

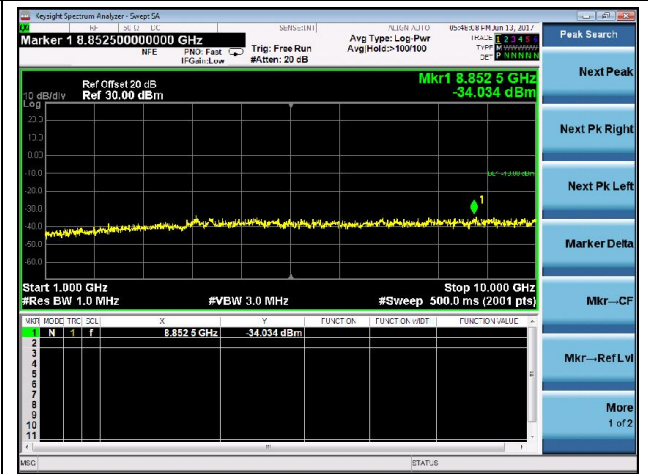
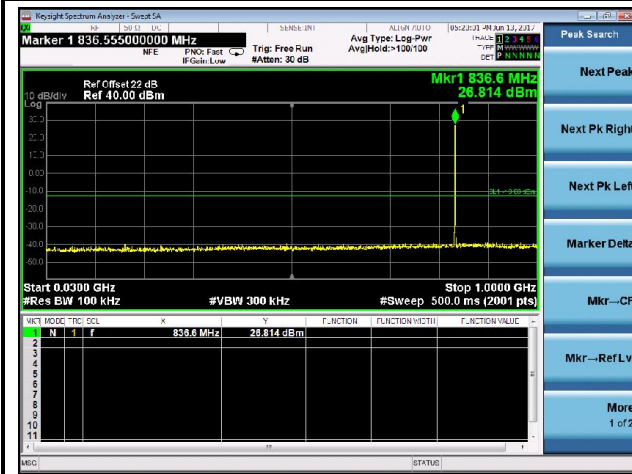

Channel 251 (848.80MHz)

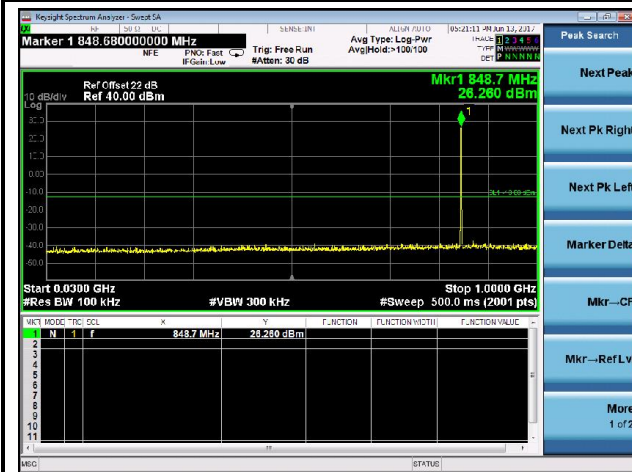

Mode	Channel No.	Frequency (MHz)	Modulation	Test Result
EDGE1900	512	1850.2	8PSK	Pass
EDGE1900	661	1880.0	8PSK	Pass
EDGE1900	810	1909.8	8PSK	Pass

