

# TEST REPORT

Applicant Name: Inrico Technologies Co.,Ltd  
Address: A1703, Shenzhen National Engineering Laboratory Building,  
No. 20 Gaoxin South 7th Road Shenzhen China  
Report Number: SZGMA240130-06895E-RF-00B  
FCC ID: 2AIV6-S380

**Test Standard (s)**  
FCC PART 15.225

## Sample Description

Product Type: Rugged PTTtoC Radio  
Model No.: S380  
Multiple Model(s) No.: N/A  
Trade Mark: **Inrico**<sup>®</sup>  
Date Received: 2024/01/30  
Issue Date: 2024/06/24

Test Result:	Pass <sup>▲</sup>
--------------	-------------------

▲ In the configuration tested, the EUT complied with the standards above.

## Prepared and Checked By:

*Gala Liu*

Gala Liu  
RF Engineer

## Approved By:

*Nancy Wang*

Nancy Wang  
RF Supervisor

Note: The information marked # is provided by the applicant, the laboratory is not responsible for its authenticity and this information can affect the validity of the result in the test report. Customer model name, addresses, names, trademarks etc. are included.

This report cannot be reproduced except in full, without prior written approval of the Company. Unless otherwise stated the results shown in this test report refer only to the sample(s) tested. This report is valid only with a valid digital signature. The digital signature may be available only under the Adobe software above version 7.0.

This report must not be used by the customer to claim product certification, approval, or endorsement by NVLAP or any agency of the U.S. Government.

This report may contain data that are not covered by the NVLAP accreditation and are marked with an asterisk "▼".

## Bay Area Compliance Laboratories Corp. (Shenzhen)

5F(B-West) , 6F, 7F, the 3rd Phase of Wan Li Industrial Building D, Shihua Rd, FuTian Free Trade Zone, Shenzhen, China

Tel: +86-755-33320018 Fax: +86-755-33320008 www.baclcorp.com.cn

## TABLE OF CONTENTS

<b>DOCUMENT REVISION HISTORY .....</b>	<b>4</b>
<b>GENERAL INFORMATION.....</b>	<b>5</b>
PRODUCT DESCRIPTION FOR EQUIPMENT UNDER TEST (EUT) .....	5
OBJECTIVE .....	5
TEST METHODOLOGY .....	5
MEASUREMENT UNCERTAINTY .....	6
TEST FACILITY .....	6
<b>SYSTEM TEST CONFIGURATION.....</b>	<b>7</b>
DESCRIPTION OF TEST CONFIGURATION .....	7
EUT EXERCISE SOFTWARE .....	7
EQUIPMENT MODIFICATIONS .....	7
SUPPORT EQUIPMENT LIST AND DETAILS .....	7
EXTERNAL I/O CABLE.....	7
BLOCK DIAGRAM OF TEST SETUP .....	8
<b>SUMMARY OF TEST RESULTS .....</b>	<b>9</b>
<b>TEST EQUIPMENT LIST .....</b>	<b>10</b>
<b>FCC§15.203 - ANTENNA REQUIREMENT.....</b>	<b>11</b>
APPLICABLE STANDARD .....	11
ANTENNA CONNECTED CONSTRUCTION .....	11
<b>FCC§1.1310 &amp; §2.1093- RF EXPOSURE .....</b>	<b>12</b>
APPLICABLE STANDARD .....	12
MEASUREMENT RESULT .....	12
<b>FCC §15.207 – AC LINE CONDUCTED EMISSION .....</b>	<b>13</b>
APPLICABLE STANDARD .....	13
EUT SETUP .....	13
EMI TEST RECEIVER SETUP.....	13
TEST PROCEDURE .....	14
FACTOR & OVER LIMIT CALCULATION.....	14
TEST DATA .....	14
<b>FCC§15.225, §15.205&amp; §15.209 - RADIATED EMISSIONS TEST .....</b>	<b>17</b>
APPLICABLE STANDARD .....	17
EUT SETUP .....	17
EMI TEST RECEIVER SETUP.....	18
LEVEL & OVER LIMIT CALCULATION .....	18
TEST DATA .....	18
<b>FCC§15.225(E) - FREQUENCY STABILITY.....</b>	<b>30</b>
APPLICABLE STANDARD .....	30
TEST PROCEDURE .....	30
TEST DATA .....	30
<b>FCC§15.215(C) - 20DBEMISSION BANDWIDTH .....</b>	<b>32</b>
REQUIREMENT .....	32
TEST PROCEDURE .....	32
TEST DATA .....	33

**EUT PHOTOGRAPHS.....34**  
**TEST SETUP PHOTOGRAPHS .....35**

### DOCUMENT REVISION HISTORY

Revision Number	Report Number	Description of Revision	Date of Revision
0	SZGMA240130-06895E-RF-00B	Original Report	2024/06/24

## GENERAL INFORMATION

### Product Description for Equipment under Test (EUT)

Product	Rugged PTTtoC Radio
Tested Model	S380
Multiple Model(s)	N/A
Frequency Range	13.56 MHz
E-field Strength	66.20dBuV/m@3m
Modulation Technique	ASK
Voltage Range	DC3.8V from Li-ion Battery or DC 5V from Type-C Port or DC5V from Charger
Sample serial number	2HCN-2 (Assigned by BACL, Shenzhen)
Sample/EUT Status	Good condition
Adapter Information	Model: SA12BV-120100U Input: AC 100-240V, 50/60Hz 0.4A Output: DC 12.0V,1.0A
Charger Information	Model: CI-80GH Input: DC12V, 1000mA Output: DC5V
Note: The EUT charged by Type-C Port or Charger, the worst case charger power supply was selected to test for AC line conducted and radiated emission below 1GHz according to DSS report test result.	

### Objective

This Type approval report is in accordance with Part 2- Subpart J, and Part 15-Subparts A and C of the Federal Communication Commissions rules.

The objective is to determine the compliance of the EUT with FCC rules, section 15.203, 15.205, 15.207, 15.209 and 15.225.

### Test Methodology

All measurements contained in this report were conducted with ANSI C63.10-2013, American National Standard of Procedures for Compliance Testing of Unlicensed Wireless Devices.

All emissions measurement was performed at Bay Area Compliance Laboratories Corp. (Shenzhen). The radiated testing was performed at an antenna-to-EUT distance of 3 meters.

Each test item follows test standards and with no deviation.

**Measurement Uncertainty**

Parameter		Uncertainty
Occupied Channel Bandwidth		±5%
RF Frequency		213.55 Hz(k=2, 95% level of confidence)
RF output power, conducted		0.72 dB(k=2, 95% level of confidence)
Unwanted Emission, conducted		1.75 dB(k=2, 95% level of confidence)
AC Power Lines Conducted Emissions	9kHz-150kHz	3.94dB(k=2, 95% level of confidence)
	150kHz-30MHz	3.84dB(k=2, 95% level of confidence)
Radiated Emissions	9kHz - 30MHz	3.30dB(k=2, 95% level of confidence)
	30MHz~200MHz (Horizontal)	4.48dB(k=2, 95% level of confidence)
	30MHz~200MHz (Vertical)	4.55dB(k=2, 95% level of confidence)
	200MHz~1000MHz (Horizontal)	4.85dB(k=2, 95% level of confidence)
	200MHz~1000MHz (Vertical)	5.05dB(k=2, 95% level of confidence)
	1GHz - 6GHz	5.35dB(k=2, 95% level of confidence)
	6GHz - 18GHz	5.44dB(k=2, 95% level of confidence)
	18GHz - 40GHz	5.16dB(k=2, 95% level of confidence)
Temperature		±1°C
Humidity		±1%
Supply voltages		±0.4%

*Note: The extended uncertainty given in this report is obtained by combining the standard uncertainty times the coverage factor K with the 95% confidence interval. Otherwise required by the applicant or Product Regulations, Decision Rule in this report did not consider the uncertainty.*

**Test Facility**

The Test site used by Bay Area Compliance Laboratories Corp. (Shenzhen) to collect test data is located on the 5F(B-West) , 6F, 7F, the 3rd Phase of Wan Li Industrial Building D, Shihua Rd, FuTian Free Trade Zone, Shenzhen, China.

The lab has been recognized as the FCC accredited lab under the KDB 974614 D01 and is listed in the FCC Public Access Link (PAL) database, FCC Registration No. : 715558, the FCC Designation No. : CN5045.

## SYSTEM TEST CONFIGURATION

### Description of Test Configuration

The system was configured for testing in a typical fashion (as normally used by a typical user).

### EUT Exercise Software

No Exercise Software was used.

### Equipment Modifications

No modification on the EUT.

### Support Equipment List and Details

Manufacturer	Description	Model	Serial Number
Unknown	Receptacle	Unknown	Unknown
Unknown	Card	Unknown	Unknown
Inrico	Headset	Unknown	Unknown

### External I/O Cable

Cable Description	Length (m)	From Port	To
Un-shielding Un-Detachable DC Cable	1.0	EUT	Charger
Un-shielding Un-Detachable AC Cable	1.5	Receptacle	LISN/AC Mains

### Block Diagram of Test Setup

For Conducted Emissions:

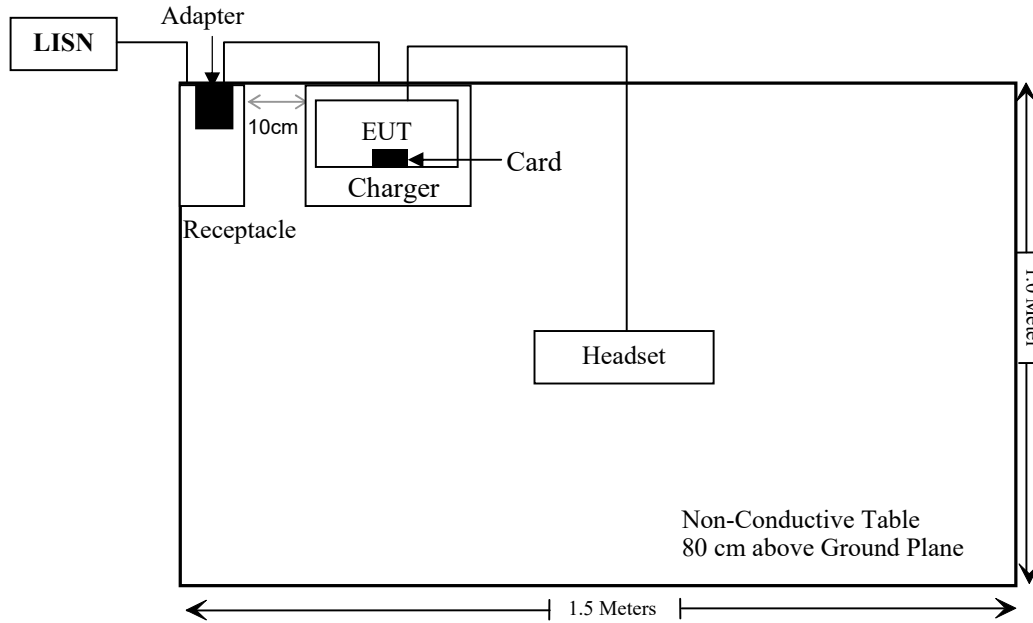

For Radiated Emissions below 1GHz:

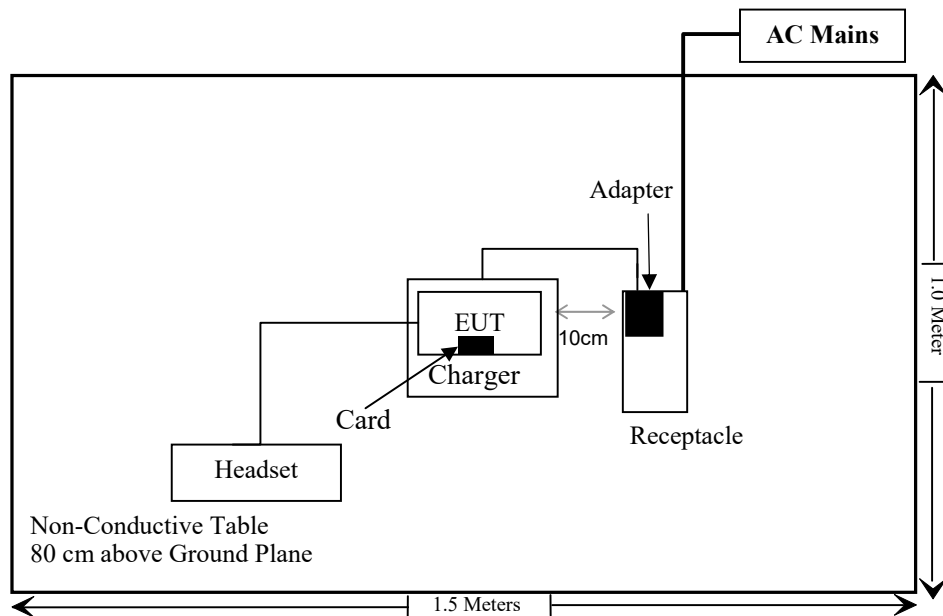



**SUMMARY OF TEST RESULTS**

<b>FCC Rules</b>	<b>Description of Test</b>	<b>Result</b>
§15.203	Antenna Requirement	Compliant
§1.1310 & §2.1093	RF Exposure	Compliant
§15.207	AC Line Conducted Emission	Compliant
§15.225 §15.209§15.205	Radiated Emission Test	Compliant
§15.225(e)	Frequency Stability	Compliant
§15.215(c)	20dB Emission Bandwidth	Compliant

**TEST EQUIPMENT LIST**

Manufacturer	Description	Model	Serial Number	Calibration Date	Calibration Due Date
<b>Conducted Emissions Test</b>					
Rohde & Schwarz	EMI Test Receiver	ESCI	101120	2024/01/16	2025/01/15
Rohde & Schwarz	LISN	ENV216	101613	2024/01/16	2025/01/15
Rohde & Schwarz	Transient Limiter	ESH3Z2	DE25985	2023/08/03	2024/08/02
Unknown	CE Cable	CE Cable	UF A210B-1-0720-504504	2023/08/03	2024/08/02
Audix	EMI Test software	E3	191218	NCR	NCR
<b>Radiated Emission Test</b>					
R&S	EMI Test Receiver	ESR3	102455	2024/01/16	2025/01/15
Sonoma instrument	Pre-amplifier	310 N	186238	2023/06/08	2024/06/07
Sonoma instrument	Pre-amplifier	310 N	186238	2024/05/21	2025/05/20
Sunol Sciences	Broadband Antenna	JB1	A040904-1	2023/07/20	2024/07/19
ETS	Passive Loop Antenna	1313-1A	4031911	2024/03/21	2025/03/20
Unknown	Cable	Chamber Cable 1	F-03-EM236	2023/08/03	2024/08/02
Unknown	Cable	Chamber Cable 4	EC-007	2023/08/03	2024/08/02
Audix	EMI Test software	E3	19821b(V9)	NCR	NCR
<b>Frequency Stability</b>					
R&S	EMI Test Receiver	ESR3	102455	2024/01/16	2025/01/15
ETS	Passive Loop Antenna	1313-1A	4031911	2024/03/21	2025/03/20
BACL	Temperature & Humidity Chamber	BTH-150-40	30145	2024/01/16	2025/01/15
instek	DC Power Supply	GPS-3030DD	EM832096	NCR	NCR
Fluke	Digital Multimeter	287	19000011	2023/06/08	2024/06/07
<b>20dB Emission Bandwidth</b>					
R&S	EMI Test Receiver	ESR3	102455	2024/01/16	2025/01/15
Sonoma instrument	Pre-amplifier	310 N	186238	2024/05/21	2025/05/20
ETS	Passive Loop Antenna	1313-1A	4031911	2024/03/21	2025/03/20
Unknown	Cable	Chamber Cable 1	F-03-EM236	2023/08/03	2024/08/02
Unknown	Cable	Chamber Cable 4	EC-007	2023/08/03	2024/08/02

\* **Statement of Traceability:** Bay Area Compliance Laboratories Corp. (Shenzhen) attests that all calibrations have been performed in accordance to requirements that traceable to National Primary Standards and International System of Units (SI).

---

## **FCC§15.203 - ANTENNA REQUIREMENT**

---

### **Applicable Standard**

An intentional radiator shall be designed to ensure that no antenna other than that furnished by the responsible party shall be used with the device. The use of a permanently attached antenna or of an antenna that uses a unique coupling to the intentional radiator shall be considered sufficient to comply with the provisions of this section.

### **Antenna Connected Construction**

The EUT has one internal antenna arrangement for NFC which was permanently attached; fulfill the requirement of this section. Please refer to the EUT photos.

**Result: Compliant.**

## **FCC§1.1310 & §2.1093- RF EXPOSURE**

### **Applicable Standard**

According to KDB447498 D01 General RF Exposure Guidance v06: 4.3. General SAR test exclusion guidance

c) For frequencies below 100 MHz, the following may be considered for SAR test exclusion (also illustrated in Appendix C):

- 1) For *test separation distances*  $> 50$  mm and  $< 200$  mm, the power threshold at the corresponding test separation distance at 100 MHz in step b) is multiplied by  $[1 + \log(100/f_{\text{(MHz)}})]$
- 2) For *test separation distances*  $\leq 50$  mm, the power threshold determined by the equation in c) 1) for 50 mm and 100 MHz is multiplied by  $\frac{1}{2}$
- 3) SAR measurement procedures are not established below 100 MHz

### **Measurement Result**

For NFC, the power of EUT: E Field@3m is 66.20dBuV/m = -29.00dBm (0.0013mW)

Note:  $E[\text{dB}\mu\text{V}/\text{m}] = \text{EIRP}[\text{dBm}] + 95.2$  for  $d = 3$  m.

SAR test exclusion threshold for NFC(13.56MHz) separation distance  $< 50$ mm

$$=[474*(1 + \log(100/f_{\text{(MHz)}}))]/2$$

$$= 443\text{mW}$$

$$> 0.0013\text{mW}$$

**Result: Compliant.**

## FCC §15.207 – AC LINE CONDUCTED EMISSION

### Applicable Standard

FCC§15.207

### EUT Setup

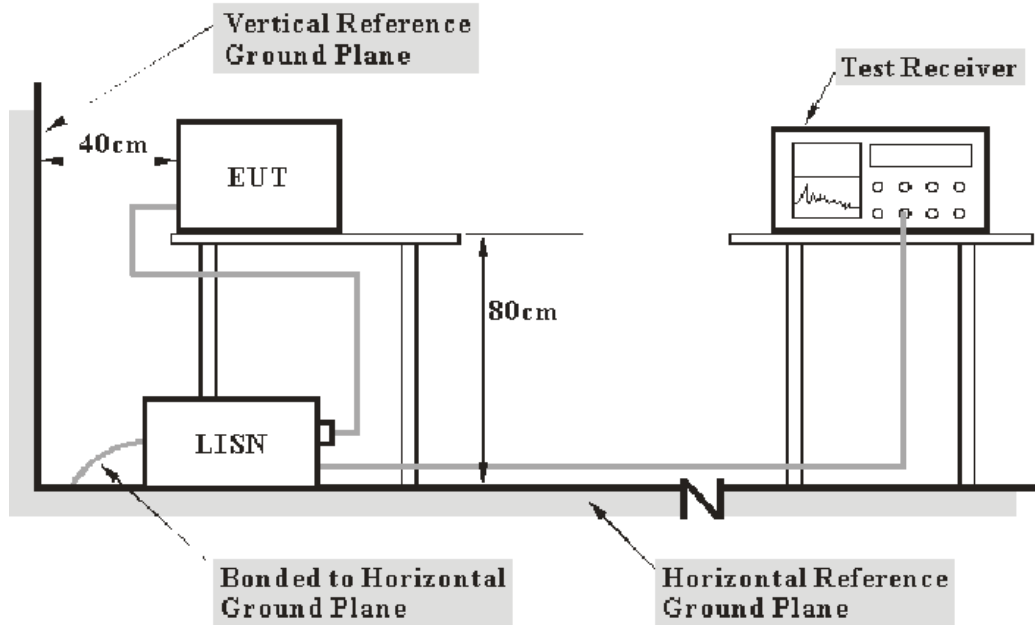

- Note: 1. Support units were connected to second LISN.  
 2. Both of LISNs (AMN) 80 cm from EUT and at the least 80 cm from other units and other metal planes support units.

The setup of EUT is according with per ANSI C63.10-2013 measurement procedure. The specification used was with the FCC Part 15.207.

The external I/O cables were draped along the test table and formed a bundle 30 to 40 cm long in the middle.

The spacing between the peripherals was 10 cm.

### EMI Test Receiver Setup

The EMI test receiver was set to investigate the spectrum from 150 kHz to 30MHz.

During the conducted emission test, the EMI test receiver was set with the following configurations:

Frequency Range	IF B/W
150 kHz – 30MHz	9 kHz

## Test Procedure

During the conducted emission test, the adapter of Host was connected to the outlet of the LISN.

Maximizing procedure was performed on the six (6) highest emissions of the EUT.

All final data was recorded in the Quasi-peak and average detection mode.

## Factor & Over Limit Calculation

The factor is calculated by adding LISN VDF (Voltage Division Factor) and Cable Loss. The basic equation is as follows:

$$\text{Factor} = \text{LISN VDF} + \text{Cable Loss}$$

The “**Over limit**” column of the following data tables indicates the degree of compliance with the applicable limit. For example, an Over limit of -7 dB means the emission is 7 dB below the limit. The equation for calculation is as follows:

$$\begin{aligned}\text{Over Limit} &= \text{Level} - \text{Limit} \\ \text{Level} &= \text{Read Level} + \text{Factor}\end{aligned}$$

Note: The term "cable loss" refers to the combination of a cable and a 10dB transient limiter (attenuator).

## Test Data

### Environmental Conditions

<b>Temperature:</b>	25°C
<b>Relative Humidity:</b>	67 %
<b>ATM Pressure:</b>	101 kPa

*The testing was performed by Macy Shi on 2024-05-23.*

*Test mode: Transmitting*

AC 120 V/60 Hz, Line

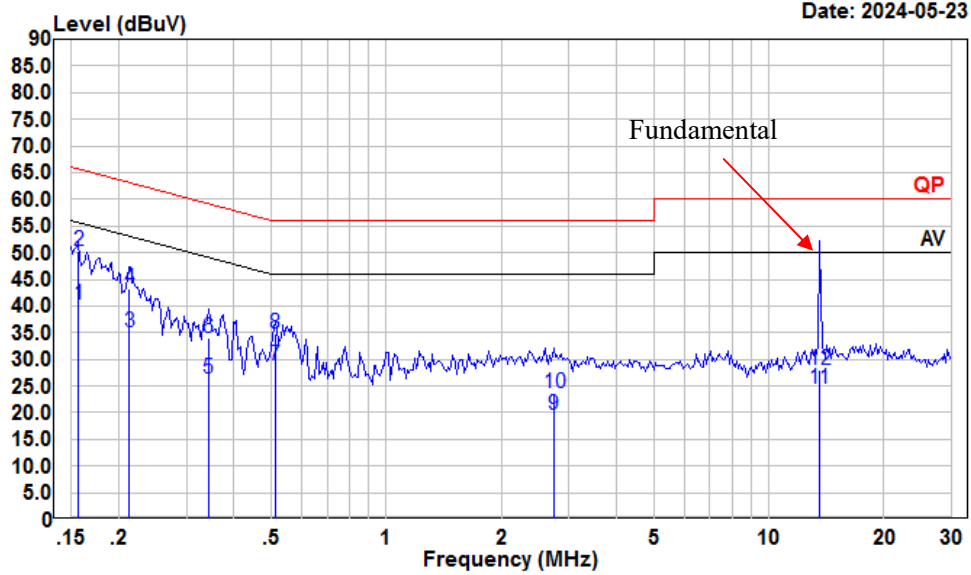

Condition: Line  
 Project : SZGMA240130-06895E-RF  
 tester : Macy.shi  
 Note : NFC Transmitting

	Read Freq	Read Level	LISN Level	LISN Factor	Cable Loss	Limit Line	Over Limit	Remark
	MHz	dBuV	dBuV	dB	dB	dBuV	dB	
1	0.16	19.30	40.34	10.89	10.15	55.65	-15.31	Average
2	0.16	29.29	50.33	10.89	10.15	65.65	-15.32	QP
3	0.21	14.27	35.17	10.78	10.12	53.10	-17.93	Average
4	0.21	22.40	43.30	10.78	10.12	63.10	-19.80	QP
5	0.34	5.74	26.51	10.62	10.15	49.13	-22.62	Average
6	0.34	13.24	34.01	10.62	10.15	59.13	-25.12	QP
7	0.51	8.10	28.76	10.50	10.16	46.00	-17.24	Average
8	0.51	14.06	34.72	10.50	10.16	56.00	-21.28	QP
9	2.74	-1.22	19.48	10.46	10.24	46.00	-26.52	Average
10	2.74	2.99	23.69	10.46	10.24	56.00	-32.31	QP
11	13.55	3.61	24.36	10.60	10.15	50.00	-25.64	Average
12	13.55	7.40	28.15	10.60	10.15	60.00	-31.85	QP

AC 120V/ 60 Hz, Neutral

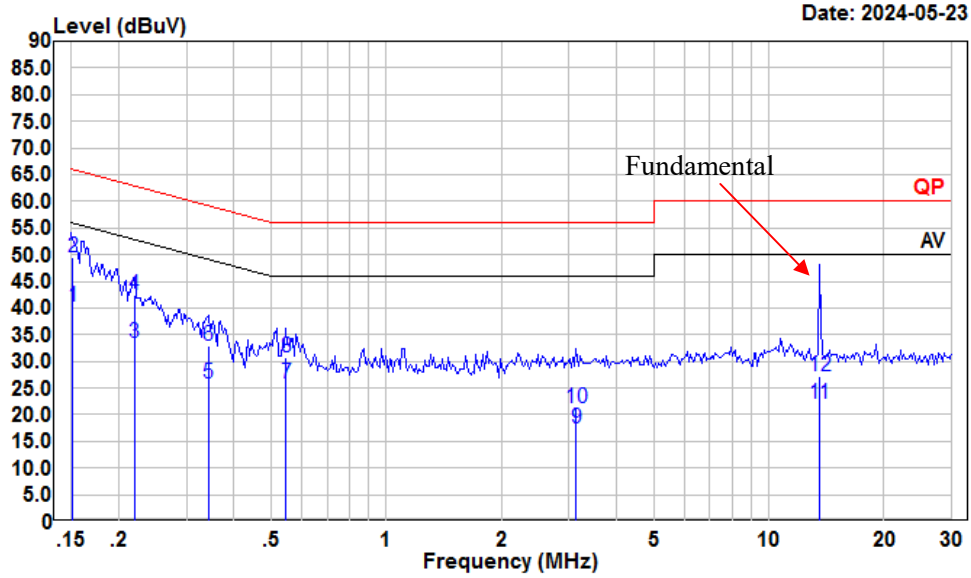

Date: 2024-05-23

Condition: Neutral  
 Project : SZGMA240130-06895E-RF  
 tester : Macy.shi  
 Note : NFC Transmitting

	Freq	Read Level	LISN Level	LISN Factor	Cable Loss	Limit Line	Over Limit	Remark
	MHz	dBuV	dBuV	dB	dB	dBuV	dB	
1	0.15	19.60	40.34	10.59	10.15	55.91	-15.57	Average
2	0.15	28.73	49.47	10.59	10.15	65.91	-16.44	QP
3	0.22	12.75	33.32	10.43	10.14	52.83	-19.51	Average
4	0.22	21.78	42.35	10.43	10.14	62.83	-20.48	QP
5	0.34	5.10	25.83	10.58	10.15	49.13	-23.30	Average
6	0.34	12.25	32.98	10.58	10.15	59.13	-26.15	QP
7	0.55	4.84	25.72	10.70	10.18	46.00	-20.28	Average
8	0.55	9.98	30.86	10.70	10.18	56.00	-25.14	QP
9	3.14	-3.16	17.51	10.40	10.27	46.00	-28.49	Average
10	3.14	0.46	21.13	10.40	10.27	56.00	-34.87	QP
11	13.55	1.05	22.00	10.80	10.15	50.00	-28.00	Average
12	13.55	6.33	27.28	10.80	10.15	60.00	-32.72	QP



## FCC§15.225, §15.205& §15.209 - RADIATED EMISSIONS TEST

### Applicable Standard

As per FCC Part 15.225

(a) The field strength of any emissions within the band 13.553–13.567 MHz shall not exceed 15,848 microvolts/meter at 30 meters.

(b) Within the bands 13.410–13.553 MHz and 13.567–13.710 MHz, the field strength of any emissions shall not exceed 334 microvolts/meter at 30 meters.

(c) Within the bands 13.110–13.410 MHz and 13.710–14.010 MHz the field strength of any emissions shall not exceed 106 microvolts/meter at 30 meters.

(d) The field strength of any emissions appearing outside of the 13.110–14.010 MHz band shall not exceed the general radiated emission limits in §15.209.

### EUT Setup

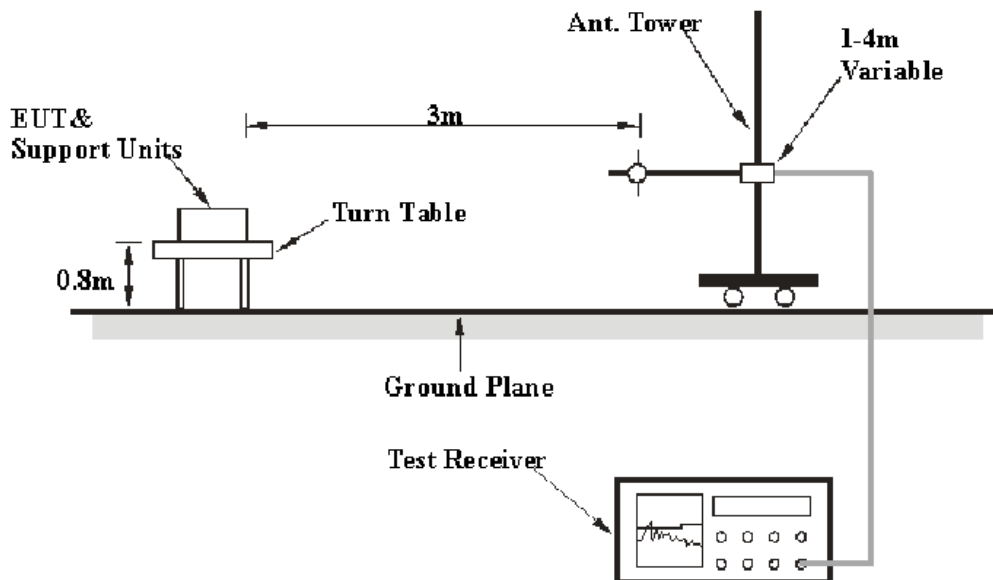

Note: Antenna is set up at 1m during test for below 30MHz.

The radiated emission tests were performed in the 3-meter chamber a test site, using the setup accordance with the ANSI C63.10-2013.

**EMI Test Receiver Setup**

According to FCC Rules, 47 CFR 15.33, the EUT emissions were investigated up to 1000 MHz.

During the radiated emission test, the EMI test Receiver was set with the following configurations:

Frequency Range	RBW	Video B/W	IF B/W	Detector
9 kHz – 150 kHz	300 Hz	1kHz	/	QP
150 kHz –30MHz	10 kHz	30 kHz	/	QP
30MHz – 1000 MHz	100 kHz	300 kHz	/	QP

Note: detector for 9-90 kHz and 110-490 kHz is average

For 9 kHz-30MHz, the report shall list the six emissions with the smallest margin relative to the limit, for each of the three antenna orientations (parallel, perpendicular, and ground-parallel) unless the margin is greater than 20 dB.

**Level & Over Limit Calculation**

The Level is calculated by adding the Antenna Factor and Cable Loss, and subtracting the Amplifier Gain from the Meter Reading. The basic equation is as follows:

$$\text{Factor} = \text{Antenna Factor} + \text{Cable Loss} - \text{Amplifier Gain}$$

$$\text{Level} = \text{Read Level} + \text{Factor}$$

The “**Over Limit**” column of the following data tables indicates the degree of compliance with the applicable limit. For example, an over Limit of -7 dB means the emission is 7 dB below the limit. The equation for margin calculation is as follows:

$$\text{Over Limit} = \text{Level} - \text{Limit}$$

**Test Data**

**Environmental Conditions**

<b>Temperature:</b>	24 °C
<b>Relative Humidity:</b>	55 %
<b>ATM Pressure:</b>	101 kPa

*The testing was performed by Anson Su from 2024-05-14 to 2024-06-22..*

*Test mode: Transmitting (Pre-scan in the X, Y and Z axes of orientation, the worst case of Y-axis orientation were recorded)*

1) Spurious Emissions (9 kHz~30 MHz):

Part 15 Section 15.31(f)(2) (9kHz-30MHz)  
 Limit @ 3m=Limit @ 300m-40\*log(3(m)/300(m))  
 Limit @ 3m=Limit @ 30m-40\*log(3(m)/30(m))

Ground-parallel  
9 kHz~150 kHz

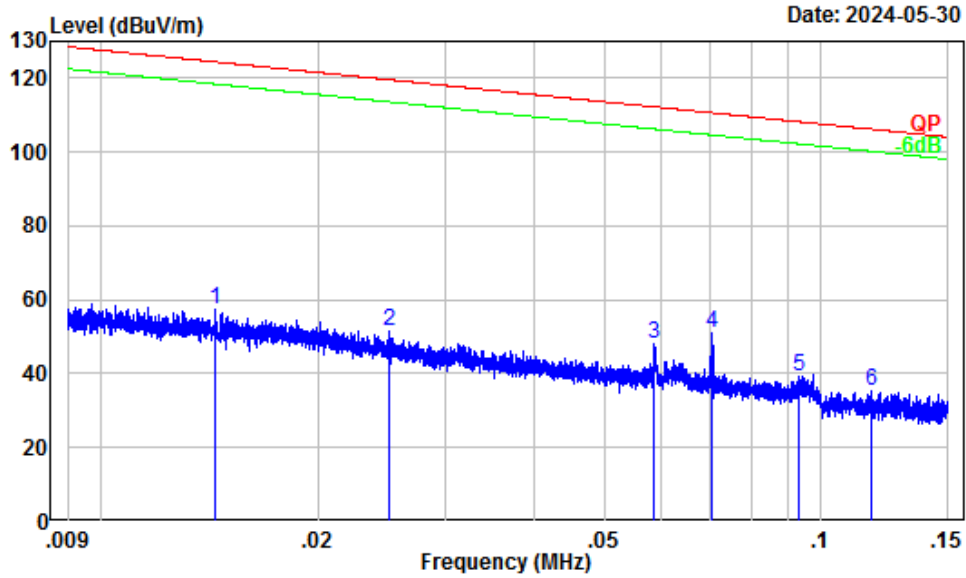

Site : Chamber A  
 Condition : 3m  
 Project Number: SZGMA240130-06895E-RF  
 Note : NFC Transmitting  
 Note : Ground-parallel  
 Tester : Anson Su

	Freq	Factor	Read		Limit		Over	Remark
			Level	Level	Line	Limit		
	MHz	dB/m	dBuV	dBuV/m	dBuV/m	dB		
1	0.01	35.45	22.09	57.54	124.44	-66.90	Peak	
2	0.03	29.99	21.51	51.50	119.62	-68.12	Peak	
3	0.06	21.91	26.08	47.99	112.24	-64.25	Peak	
4	0.07	20.31	30.67	50.98	110.64	-59.66	Peak	
5	0.09	17.73	21.40	39.13	108.22	-69.09	Peak	
6	0.12	16.23	19.17	35.40	106.20	-70.80	Peak	

150 kHz~30 MHz

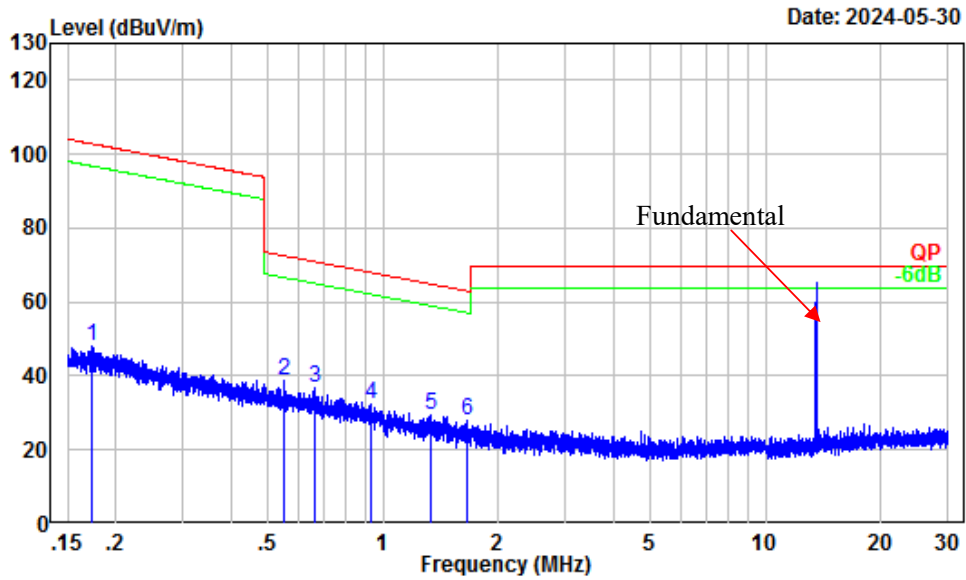

Site : Chamber A  
 Condition : 3m  
 Project Number: SZGMA240130-06895E-RF  
 Note : NFC Transmitting  
 Note : Ground-parallel  
 Tester : Anson Su

	Freq Factor		Read Level		Limit Line	Over Limit	Remark
	MHz	dB/m	dBuV	dBuV/m	dBuV/m	dB	
1	0.17	13.60	34.38	47.98	102.79	-54.81	Peak
2	0.55	2.86	35.66	38.52	72.75	-34.23	Peak
3	0.66	1.54	35.40	36.94	71.13	-34.19	Peak
4	0.93	-1.09	33.36	32.27	68.09	-35.82	Peak
5	1.33	-2.74	32.27	29.53	64.94	-35.41	Peak
6	1.65	-3.86	31.68	27.82	63.02	-35.20	Peak

Perpendicular  
9 kHz~150 kHz

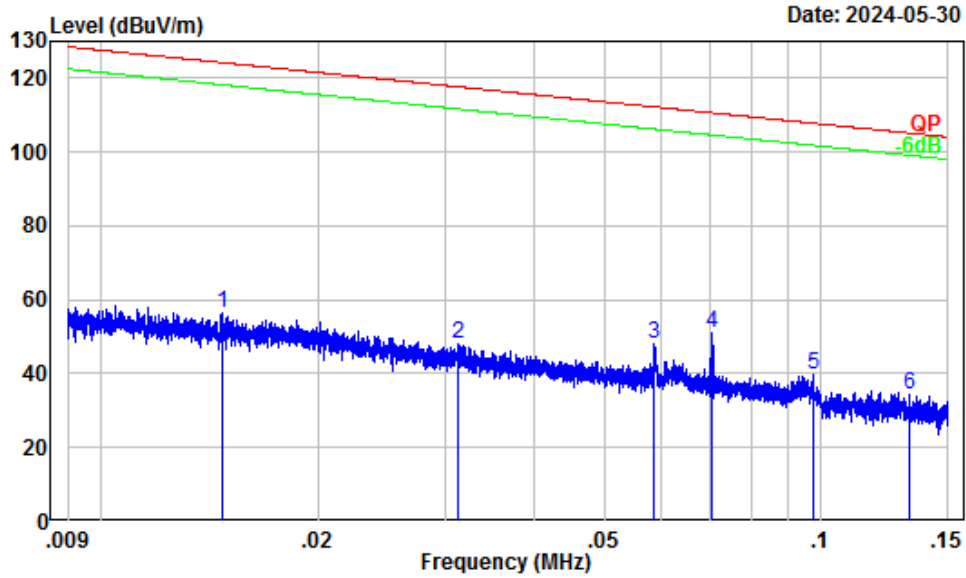

Site : Chamber A  
 Condition : 3m  
 Project Number: SZGMA240130-06895E-RF  
 Note : NFC Transmitting  
 Note : Perpendicular  
 Tester : Anson Su

	Freq	Factor	Read		Limit		Over	Remark
			Level	Level	Line	Limit		
	MHz	dB/m	dBuV	dBuV/m	dBuV/m	dB		
1	0.01	35.28	21.17	56.45	124.24	-67.79	Peak	
2	0.03	27.20	21.11	48.31	117.70	-69.39	Peak	
3	0.06	21.91	26.08	47.99	112.24	-64.25	Peak	
4	0.07	20.31	30.67	50.98	110.64	-59.66	Peak	
5	0.10	17.31	22.18	39.49	107.84	-68.35	Peak	
6	0.13	15.53	18.66	34.19	105.15	-70.96	Peak	

150 kHz~30 MHz

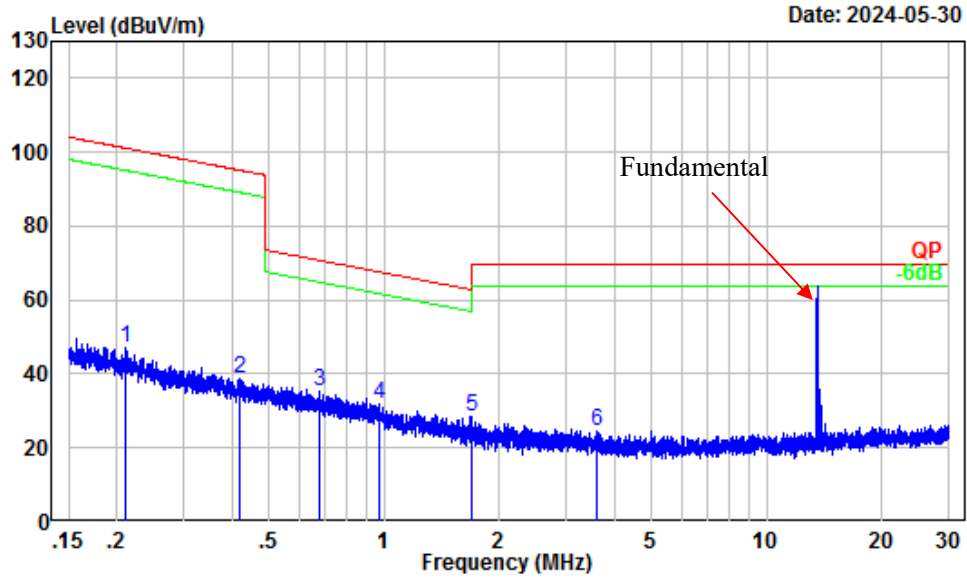

Site : Chamber A  
 Condition : 3m  
 Project Number: SZGMA240130-06895E-RF  
 Note : NFC Transmitting  
 Note : Perpendicular  
 Tester : Anson Su

	Freq	Factor	Read Level	Level	Limit	Over	Remark
	MHz	dB/m	dBuV	dBuV/m	dBuV/m	dB	
1	0.21	11.83	35.48	47.31	101.09	-53.78	Peak
2	0.42	5.17	33.75	38.92	95.13	-56.21	Peak
3	0.68	1.33	34.09	35.42	70.90	-35.48	Peak
4	0.97	-1.37	33.28	31.91	67.75	-35.84	Peak
5	1.69	-4.01	32.28	28.27	62.79	-34.52	Peak
6	3.61	-6.41	30.79	24.38	69.54	-45.16	Peak

Parallel  
9 kHz~150 kHz

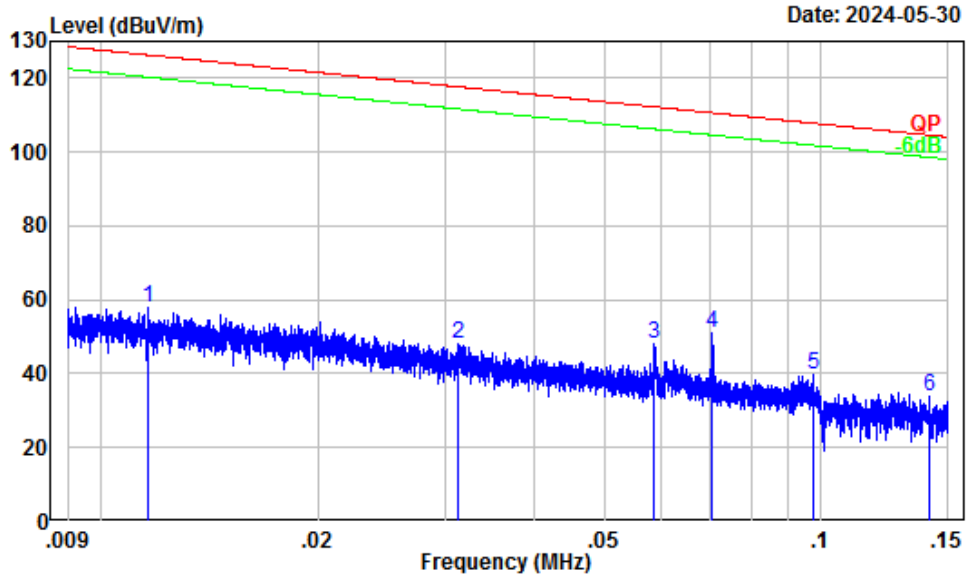

Site : Chamber A  
 Condition : 3m  
 Project Number: SZGMA240130-06895E-RF  
 Note : NFC Transmitting  
 Note : Parallel  
 Tester : Anson Su

	Freq	Factor	Read		Limit		Over	Remark
			Level	Level	Line	Limit		
	MHz	dB/m	dBuV	dBuV/m	dBuV/m	dB		
1	0.01	36.86	20.91	57.77	126.30	-68.53	Peak	
2	0.03	27.20	21.11	48.31	117.70	-69.39	Peak	
3	0.06	21.91	26.08	47.99	112.24	-64.25	Peak	
4	0.07	20.31	30.67	50.98	110.64	-59.66	Peak	
5	0.10	17.31	22.18	39.49	107.84	-68.35	Peak	
6	0.14	15.13	18.51	33.64	104.60	-70.96	Peak	

150 kHz~30 MHz

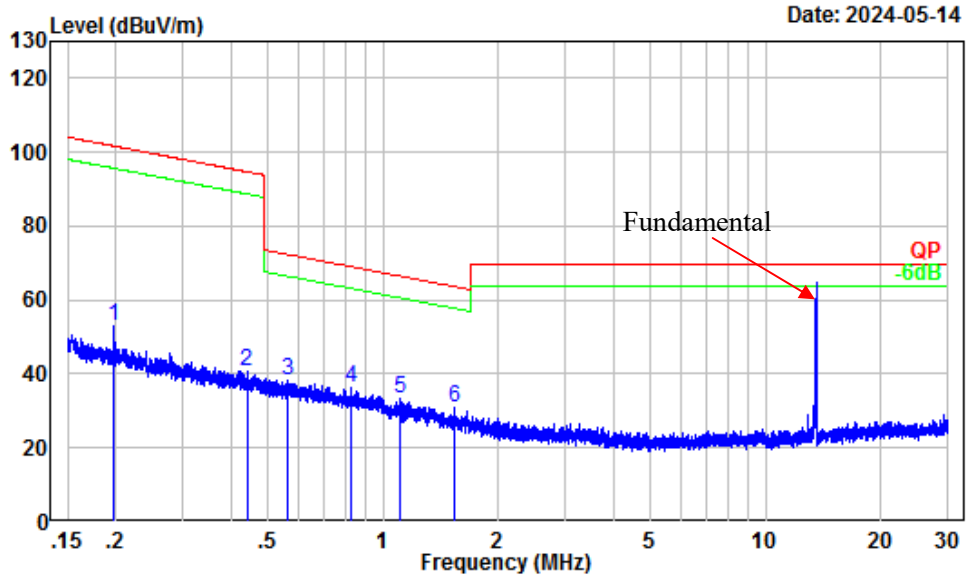

Site : Chamber A  
 Condition : 3m  
 Project Number: 2401S64436E-RF  
 Note : NFC Transmitting  
 Note : Parallel  
 Tester : Anson Su

	Freq		Read		Limit	Over	Remark
	MHz	dB/m	dBuV	dBuV/m	Line	Limit	
1	0.20	12.51	40.26	52.77	101.70	-48.93	Peak
2	0.44	4.73	36.13	40.86	94.72	-53.86	Peak
3	0.57	2.70	35.52	38.22	72.53	-34.31	Peak
4	0.82	-0.27	36.45	36.18	69.21	-33.03	Peak
5	1.11	-1.99	35.18	33.19	66.52	-33.33	Peak
6	1.54	-3.46	34.15	30.69	63.66	-32.97	Peak



2) Emission Mask & Fundamental:

Ground-parallel

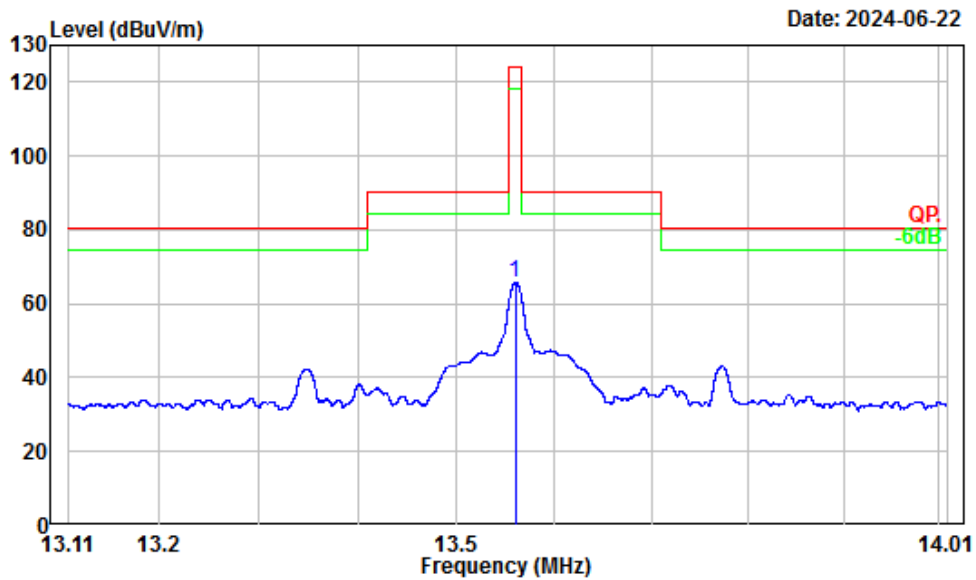

Site : Chamber A  
 Condition : 3m  
 Project Number: SZGMA240130-06895E-RF  
 Note : NFC Transmitting  
 Note : Ground-parallel  
 Tester : Anson Su

	Freq Factor		Read Level		Limit Line	Over Limit	Remark
	MHz	dB/m	dBuV	dBuV/m	dBuV/m	dB	
1	13.56	-5.69	71.52	65.83	124.00	-58.17	Peak

Perpendicular

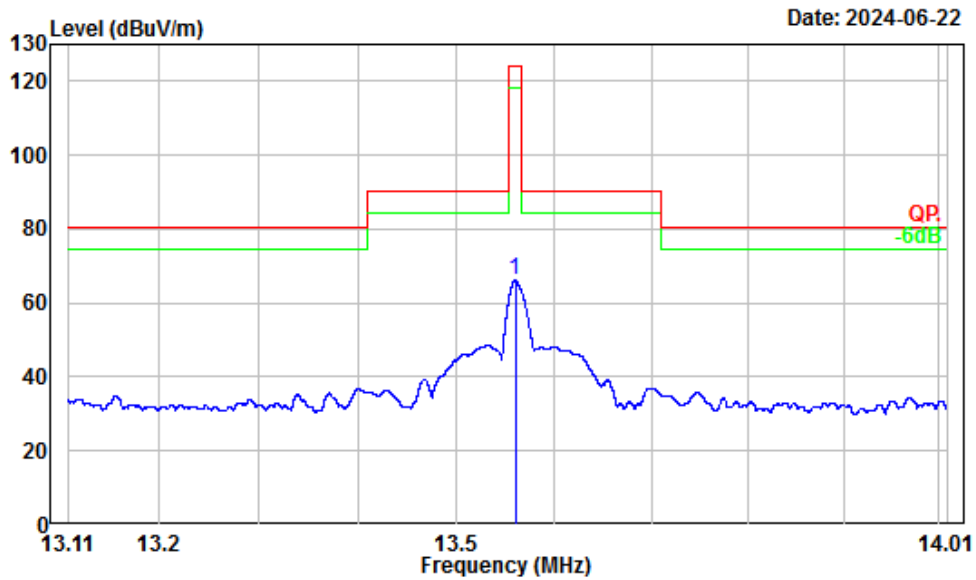

Site : Chamber A  
 Condition : 3m  
 Project Number: SZGMA240130-06895E-RF  
 Note : NFC Transmitting  
 Note : Perpendicular  
 Tester : Anson Su

	Freq	Factor	Read		Limit	Over	Remark
			Level	Level	Line	Limit	
	MHz	dB/m	dBuV	dBuV/m	dBuV/m	dB	
1	13.56	-5.69	71.74	66.05	124.00	-57.95	Peak

Parallel

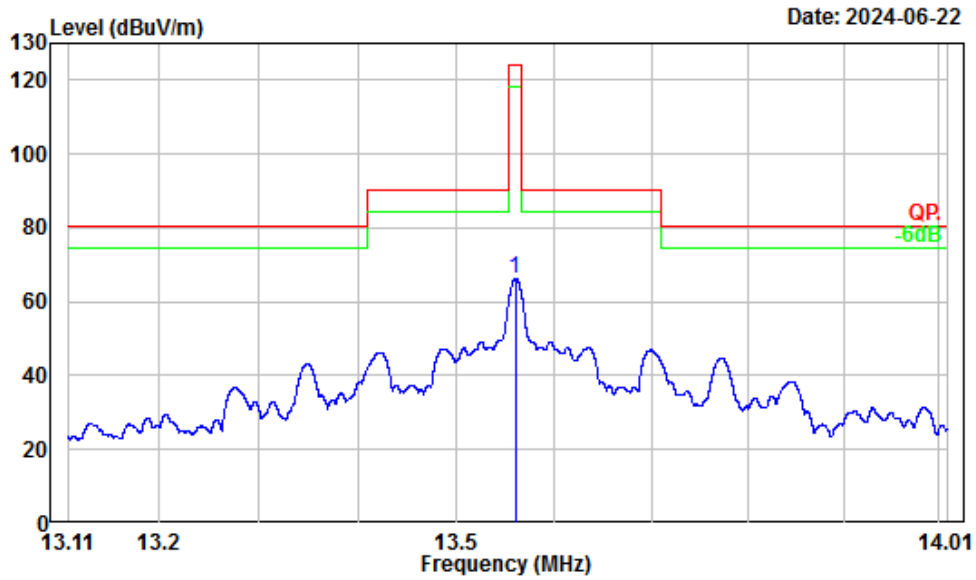

Site : Chamber A  
 Condition : 3m  
 Project Number: SZGMA240130-06895E-RF  
 Note : NFC Transmitting  
 Note : Parallel  
 Tester : Anson Su

	Freq	Factor	Read		Limit	Over	Remark
			Level	Level	Line	Limit	
	MHz	dB/m	dBuV	dBuV/m	dBuV/m	dB	
1	13.56	-5.69	71.89	66.20	124.00	-57.80	Peak

3) Spurious Emissions (30 MHz~1GHz):

**Horizontal**

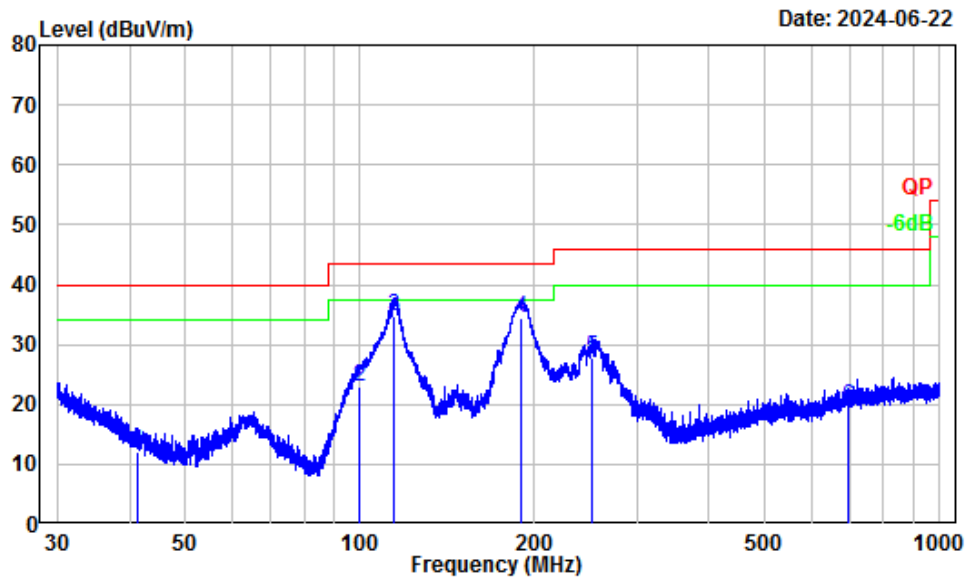

Site : Chamber A  
 Condition : 3m Horizontal  
 Project Number: SZGMA240130-06895E-RF  
 Test Mode : NFC Transmitting  
 Tester : Anson Su

	Freq	Factor	Read Level	Limit Level	Limit Line	Over Limit	Remark
	MHz	dB/m	dBuV	dBuV/m	dBuV/m	dB	
1	41.19	-12.28	24.22	11.94	40.00	-28.06	QP
2	99.83	-15.47	38.40	22.93	43.50	-20.57	QP
3	114.56	-12.75	47.42	34.67	43.50	-8.83	QP
4	190.15	-14.66	49.00	34.34	43.50	-9.16	QP
5	250.96	-14.50	42.40	27.90	46.00	-18.10	QP
6	695.94	-6.20	25.85	19.65	46.00	-26.35	QP

**Vertical**

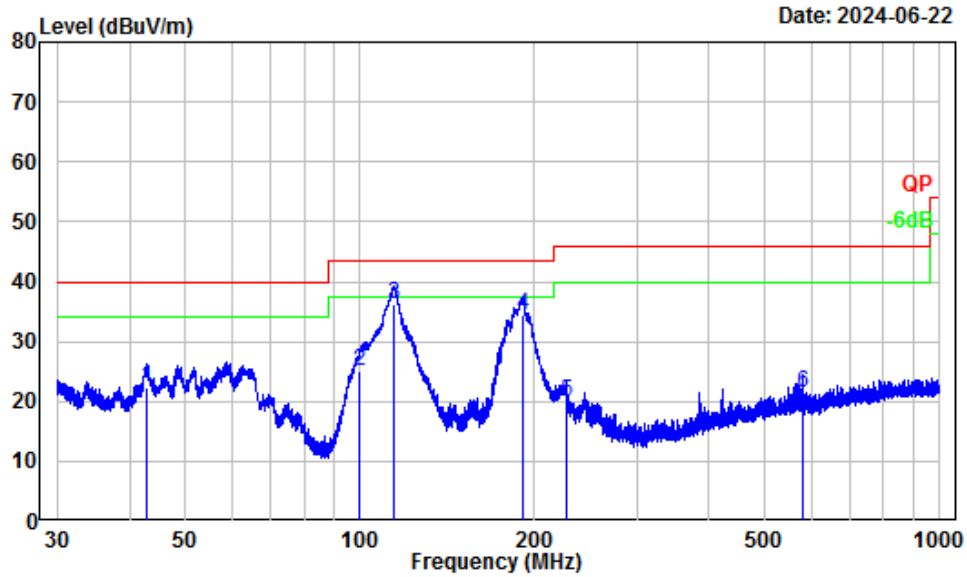

Date: 2024-06-22

Site : Chamber A  
 Condition : 3m Vertical  
 Project Number: SZGMA240130-06895E-RF  
 Test Mode : NFC Transmitting  
 Tester : Anson Su

	Freq Factor		Read Level		Limit	Over	Remark
	MHz	dB/m	dBuV	dBuV/m	Line	Limit	
1	42.75	-14.58	36.85	22.27	40.00	-17.73	QP
2	100.01	-16.93	42.08	25.15	43.50	-18.35	QP
3	114.11	-13.65	50.00	36.35	43.50	-7.15	QP
4	190.82	-15.23	49.60	34.37	43.50	-9.13	QP
5	226.79	-14.82	34.90	20.08	46.00	-25.92	QP
6	578.92	-8.24	29.78	21.54	46.00	-24.46	QP

## FCC§15.225(e) - FREQUENCY STABILITY

### Applicable Standard

The frequency tolerance of the carrier signal shall be maintained within  $\pm 0.01\%$  of the operating frequency over a temperature variation of  $-20$  degrees to  $+50$  degrees C at normal supply voltage, and for a variation in the primary supply voltage from 85% to 115% of the rated supply voltage at a temperature of 20 degrees C. For battery operated equipment, the equipment tests shall be performed using a new battery.

### Test Procedure

Frequency Stability vs. Temperature: The equipment under test was connected to an external DC power supply and inductive antenna was connected to a Spectrum Analyzer. The EUT was placed inside the temperature chamber.

After the temperature stabilized for approximately 20 minutes, the frequency output was recorded from the Spectrum Analyzer.

Frequency Stability vs. Voltage: An external DC power supply Source. The voltage was set to 115% of the nominal value and was then decreased until the transmitter light no longer illuminated; i.e., the end point. The output frequency was recorded for each voltage.

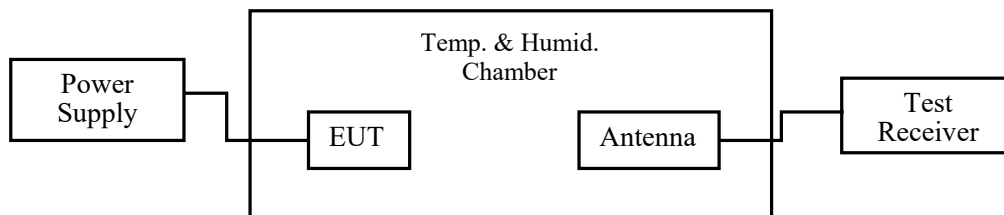

### Test Data

#### Environmental Conditions

<b>Temperature:</b>	24 °C
<b>Relative Humidity:</b>	54 %
<b>ATM Pressure:</b>	101kPa

*The testing was performed by Anson Su on 2024-05-30.*

*Test Mode: Transmitting*

**Test Result: Pass**

Test Item	Temperature (°C)	Voltage (V <sub>DC</sub> )	Measured Frequency (MHz)	Frequency Error (%)	Part 15.225 Limit (%)
Frequency Stability vs. Temperature	-20	3.8	13.56101	0.0074	±0.01
	-10	3.8	13.56103	0.0076	±0.01
	0	3.8	13.56105	0.0077	±0.01
	10	3.8	13.56108	0.0080	±0.01
	20	3.8	13.56101	0.0074	±0.01
	30	3.8	13.56102	0.0075	±0.01
	40	3.8	13.56103	0.0076	±0.01
Frequency Stability vs. Voltage	50	3.8	13.56104	0.0077	±0.01
	20	3.23	13.56109	0.0080	±0.01
	20	4.37	13.56107	0.0079	±0.01

Note: the extreme voltage was declared by the applicant.

## FCC§15.215(c) - 20dBEMISSION BANDWIDTH

### Requirement

Per 15.215 (c) Intentional radiators operating under the alternative provisions to the general emission limits, as contained in §§ 15.217 through 15.257 and in Subpart E of this part, must be designed to ensure that the 20 dB bandwidth of the emission, or whatever bandwidth may otherwise be specified in the specific rule section under which the equipment operates, is contained within the frequency band designated in the rule section under which the equipment is operated. The requirement to contain the designated bandwidth of the emission within the specified frequency band includes the effects from frequency sweeping, frequency hopping and other modulation techniques that may be employed as well as the frequency stability of the transmitter over expected variations in temperature and supply voltage. If a frequency stability is not specified in the regulations, it is recommended that the fundamental emission be kept within at least the central 80% of the permitted band in order to minimize the possibility of out-of-band operation.

### Test Procedure

Measure the frequency difference of two frequencies that were attenuated 20 dB from the reference level. Record the frequency difference as the emission bandwidth.

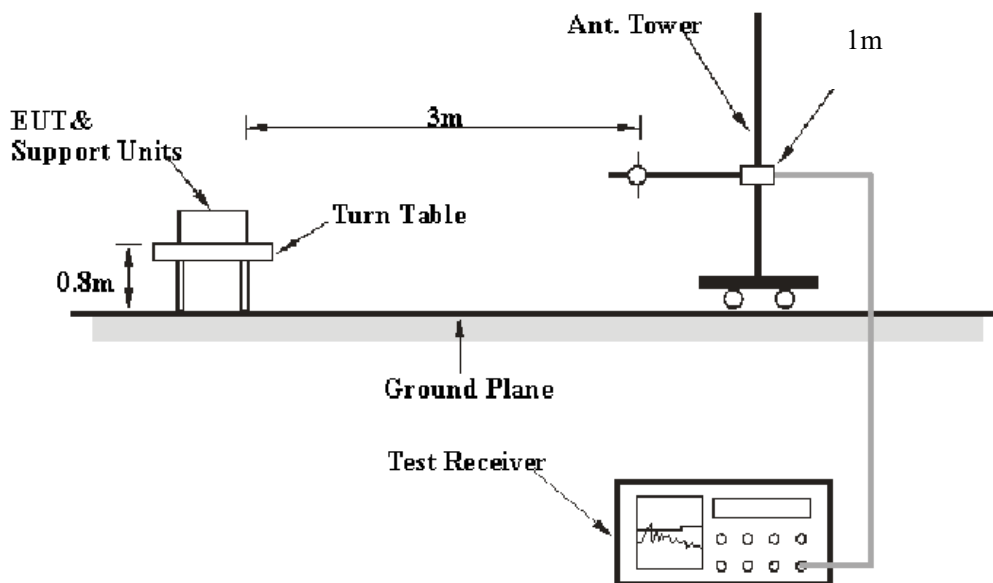



**Test Data**

**Environmental Conditions**

<b>Temperature:</b>	24 °C
<b>Relative Humidity:</b>	54 %
<b>ATM Pressure:</b>	101kPa

The testing was performed by Anson Su on 2024-05-30.

Test Mode: Transmitting

Test Result: Pass

Test Frequency (MHz)	20dB Bandwidth (kHz)
13.56	1.450

**20 dB Emission Bandwidth**

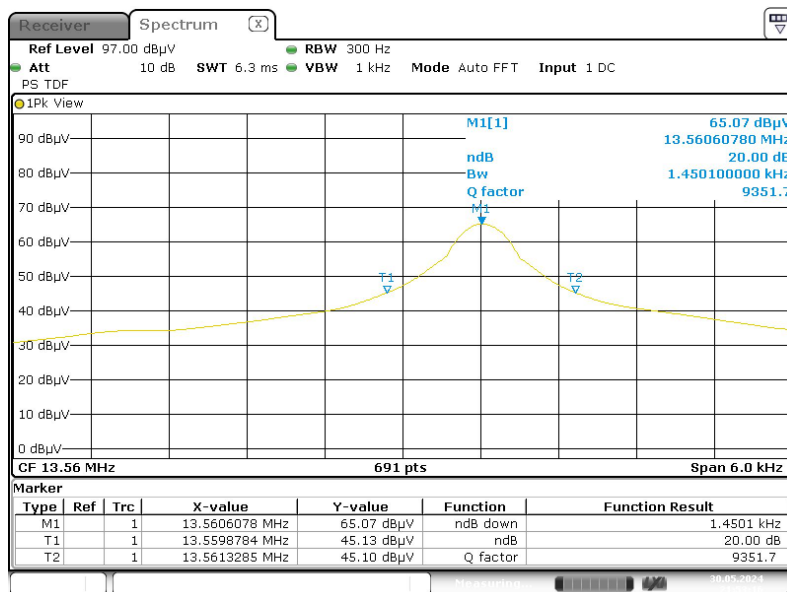

ProjectNo.:SZGMA240130-06895E-RF Tester:Anson Su  
Date: 30.MAY.2024 21:53:16

## **EUT PHOTOGRAPHS**

---

Please refer to the attachment SZGMA240130-06895E-RF External photo and SZGMA240130-06895E-RF Internal photo.

## **TEST SETUP PHOTOGRAPHS**

---

Please refer to the attachment SZGMA240130-06895E-RFC Test Setup photo.

**\*\*\*\*\* END OF REPORT \*\*\*\*\***