

# USER GUIDE

# I-10



BODY WORN CAMERA

**Inrico**<sup>®</sup>  
SINCE 2004

**Inrico**<sup>®</sup>  
SINCE 2004

# 记录仪



# I-10

# 使用说明书

使用前请仔细阅读本说明书并小心保管

[www.inricosolutions.com](http://www.inricosolutions.com)

## 使用前须知

请仔细阅读以下内容，使用者对使用本机的一般危险性的了解和认识非常重要。

- 请勿在易燃易爆环境如煤气，粉尘，蒸汽等情况下使用本机或对电池进行充电。
- 在加油或停车于加油站时，请关闭本机。
- 请勿在任何情况下擅自改装或调整本机。
- 请勿让本机受到长时间阳光直射或放置于加热器具附近。
- 请勿将本机放在极度多尘，潮湿，水溅，以及不平稳的表面上。
- 请勿自行拆装，维修仅限专业技术人员。般危险性的了解和认识非常重要。

## 目录

开箱和装置检查.....	01
随机附件.....	01
操作安全说明.....	02
电池安全说明.....	03
使用前充电.....	03
电池长时间保存.....	03
锂电池的特性.....	03
对电池进行充电.....	03
熟悉本机.....	05
功能说明.....	07
配件安装.....	08
安装SIM卡.....	08
安装带夹.....	08
安装肩夹.....	09
安装电池.....	09
基本功能.....	10
开机/关机.....	10
用户登录.....	10
呼叫使用.....	10
夜视模式.....	10
指示灯状态说明.....	10
操作说明.....	11
界面操作.....	12
连接网络.....	12
连接无线网络.....	12
连接移动网络.....	12
非系统性APP停止运行.....	12
简单故障排除.....	13
规格参数.....	14

## 开箱和设备检查

请小心从包装箱中取出对讲机。我们建议您在废弃包装材料之前确认一下箱内是否有下表列出的物品。若有任何物品在搬运中丢失或损坏，请与我们的经销商联系确认。

## 操作安全说明

### ※ 请不要对电池充电时间过长

如果对电池的充电在规定时间内仍未完成，请停止充电。电池可能会过热和冒烟爆裂或突然起火。

### ※ 请不要将电池放入微波炉和高压容器

电池可能会过热和冒烟爆裂或突然起火。

### ※ 请不要让破裂并泄漏的电池靠近火源

如果电池泄漏或发出刺鼻的气味，立即将其远离易燃区域。电池泄漏的电解液容易起火，可能会导致电池冒烟或突然起火。

### ※ 请不要使用异常电池

如果电池发出刺鼻的气味，颜色看上去不同，变形或者因任何原因而表现异常，请将电池从充电器或操作装置上取下不要使用。

### ※ 请使用专用充电器

充电器是专门为该型号设备所设计的，对本机电池的充电更为科学合理，安全可靠。

## 电池安全说明

### 在使用之前先对电池充电

为尽量减少电池放电，请不要使用电池时将电池从装置上取下来，并保存在阴凉干燥处。

### 在长时间存放电池时请从设备上拆卸电池

● 如果10天或更长时间不使用电池，则需将电池放电至40%-65%，以延长电池寿命。

● 当电池闲置超过10天时，需将电池放电到65%以下存储，防止电池鼓包。

● 将电池存放在阴凉干燥处(温度低于25摄氏度)。

### 锂电池的特性

● 电池经反复充电、放电，其容量逐渐减少。

● 即使电池从不使用也会老化。

● 在较阴凉处对锂电池充电，所需的时间较长。

● 在较热处对电池充电会缩短其使用寿命。在较热处存放电池时，电池老化的更快。请不要将电池留在车内和放在加热具附近。

● 如果电池使用时间变短，即使已经满电，也请更换电池。继续对电池进行充电和放电，将导致电解液泄漏。

### 座充充电

设备通过充电器接通电源后，红色指示灯亮代表接触良好，绿色指示灯亮代表充电完成，在充电过程中如果温度超过使用范围，或电池损坏、接触不良，指示灯不亮。

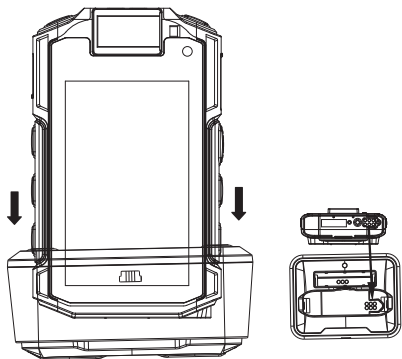

### USB 线充电

将 micro USB 线对准设备端接口插入，另一端 USB 线接口连接适配器，适配器通电后，LED 指示灯亮为充电状态。

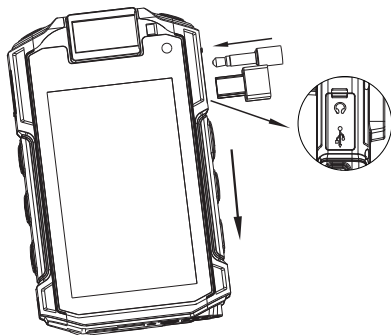



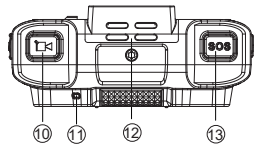
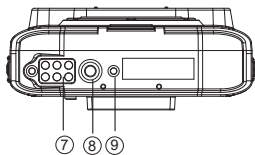
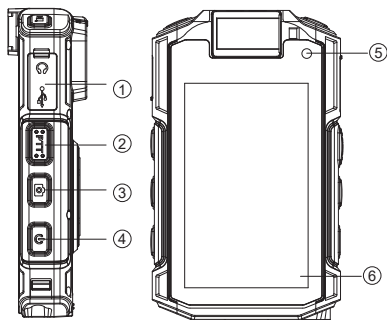

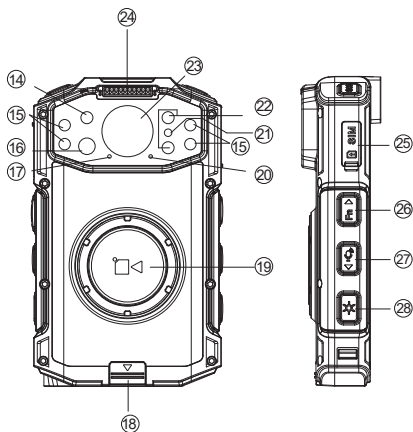



### 熟悉本机





1	耳机/USB 接口	15	红外灯
2	PTT	16	后摄像头
3	拍照键	17	状态指示灯
4	电源键	18	电池扣
5	前摄像头	19	录像键
6	显示屏	20	麦克风
7	充电接口	21	光感
8	支架旋钮	22	手电筒
9	麦克风	23	广角摄像头
10	录像键	24	警示灯
11	状态指示灯	25	SIM卡
12	喇叭	26	音控+
13	求救信号键	27	录音/音控-键
14	激光灯	28	灯光键

## 功能说明

按键	名称	功能
	求救信号键	● 长按一下预警到指挥中心，视频会上传到服务器。 4短按一下标记视频为重要文件。
	录像键	录像键按一下会进行执法视频录制状态，录像中短按一下停止录像。
	音控键	音控键短按一下增加音量。
	录音键	● 录音键短按启动录音功能，再次长按停止录音。 ● 短按一下进行音量减。
	灯光键	● 灯光键长按启动警灯闪烁，再次长按关闭警灯闪烁。 ● 快速按两下启动激光灯，再次快速按两下关闭激光灯。 ● 短按开启和关闭夜间拍摄。
	PTT键	PTT键按下说话进行对讲松开发送语音并接收其它设备发送的对讲语音,此功能需要指挥中心开启权限实现实时对讲功能。
	拍照键	短按一下进行相机拍照，长按进入手电筒。
	电源键	● 电源键关机状态下长按2/s开机，开机状态按一下提示关机、重启选项。 ● 长按8/s设备进行强制重启。

## 配件安装

- 1. 安装SIM卡。** 设备支持NANO大小的SIM卡。  
您可以通过设备左侧的SIM卡槽安装SIM卡。

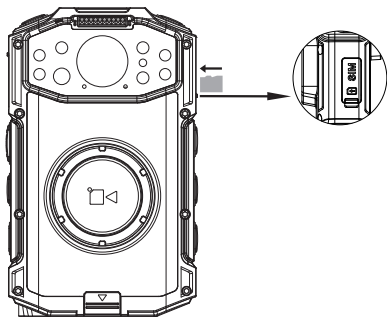

## 2. 安装/拆卸带夹

**卸下带夹：**将带夹对准卡槽定位，插入扣紧，顺时针旋转90°。

**卸下带夹：**按逆时针90°方向将背夹拔出。

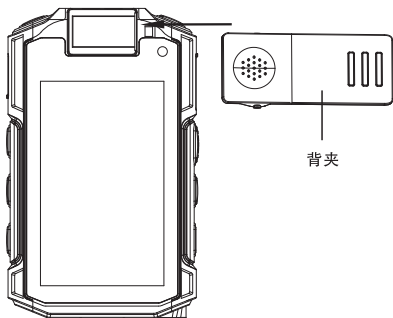

## 3. 安装/拆卸肩夹

**安装带夹：**背夹对准卡槽定位，插入扣紧。

**卸下背夹：**触动弹片抬起即可拔出。

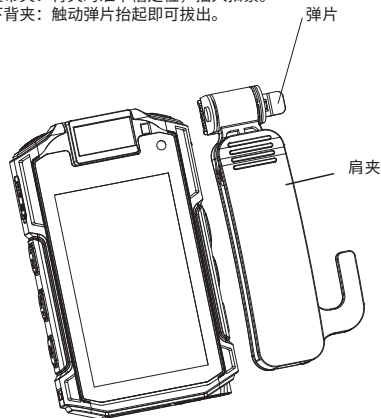

## 4. 安装电池

- 打开电池盖：打开电池盖卡扣，然后可以轻松取出电池盖。
- 将带有金属触点的一端插入电池槽底部。
- 向下按压电池另一端。
- 密合电池盖：将电池盖装好，锁上电池盖卡扣。

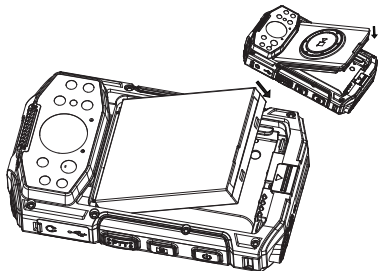

## 基本功能

### ● 开机

长按开机键3s等待开机等待程序启动。

### ● 关机

长按开机键3s关机。

如果此时设备处于充电状态,设备亮红灯并显示当前电量。

### ● 用户登录

用户登陆成功后,播报当前用户信息。

### ● 呼叫使用

按下PTT键,即可开始对讲。

设备处于呼叫状态,led灯长亮红灯;如果设备处于接听状态,LED灯长亮红灯;设备属于空闲状态为绿灯;每次每人最长通话时间限制在60秒内,如果超过60秒,则自动释放话权(可以APP设置成1-60s)。

### ● 红外线路模式

当红外模式打开的情况下,设备进入录像、视频直播或摄像模式时,设备会根据设备所处的照明环境自动判断摄像机是否需要进入红外模式。

## 指示灯状态说明

序号	工作状态	LED指示灯	
		颜色	持续时长
1	呼叫状态(对讲)	红色	长亮
2	接听(对讲)	红色	长亮
3	充电状态	红色	长亮
4	充电状态——充满电	绿色	长亮
5	正常待机状态	绿色	长亮
6	极低电(低于15%)	红色	闪烁(3秒1次)

## 操作说明

### 界面操作

预览界面:设备开机进入预览界面,该界面按返回虚拟键可进入主界面



主界面中有6个功能菜单,点击相应菜单可进入相关功能



设置菜单可以对GPS/WIFI/蓝牙、语言、时间日期、红外开关等功能进行设置



多媒体回放,可以查看视频、图片和录音





## 连接网络

### 1. 连接无线网络

打开设备点击“设置(Settings)”图标后,找到📶图标点击进入反复选框,选择一个想要连接的无线网点该无线网,输入该无线网的密码即可。



### 2. 连接移动数据网络

点开对讲机下拉菜单,点击移动数据,找到移动网络打开,即可选择需要的网络类型。



## 非系统性APP停止运行

设置 > 应用程序 > 选择要停止运行的 APP > 停止运行



## 简单故障排除

现象	解决方案
无法开机	<ul style="list-style-type: none"><li>● 电池可能安装错误。拆卸并重新接上电池。</li><li>● 电池可能没电了。充电或更换电池。</li><li>● 电池可能因脏或损坏而接触不良。</li><li>● 电池接触, 清洁电池触点或更换电池触点电池。</li></ul>
终端死机	<ul style="list-style-type: none"><li>● 程序运行过多, 强制停止一些正在运行的应用程序或重新启动终端。</li></ul>
按键无反应	<ul style="list-style-type: none"><li>● 按键可能无法正常工作时, 重新启动终端。</li><li>● 按键坏了, 请与经销商或本公司联系客服。</li></ul>
显示屏白屏	<ul style="list-style-type: none"><li>● 显示屏可能无法正常工作时, 重新启动终端。</li><li>● 显示屏坏了, 客户服务请与经销商或本公司联系。</li></ul>
连接有回音或者噪音	<ul style="list-style-type: none"><li>● 通信信号可能较弱, 确保终端在网络覆盖范围内。</li><li>● 扬声器可能被挡住, 清洁扬声器表面。</li></ul>
无法检测到SIM卡	<ul style="list-style-type: none"><li>● SIM卡可能安装不正确, 拆卸并重新连接SIM卡。</li><li>● SIM卡可金属触点脏或损坏造成的触点, 清洁金属触点。</li></ul>
无法定位	<ul style="list-style-type: none"><li>● 位置信号弱, 终端可能无法接收信号。搬到开阔平坦的地方, 再试一次。</li></ul>
电池无法充电	<ul style="list-style-type: none"><li>● 电源适配器插头可能损坏或接触不良, 拔出并重新插入适配器。</li><li>● 数据线连接器可能损坏或接触不良, 拔出并重新插入电缆。</li></ul>
待机时间缩短	<ul style="list-style-type: none"><li>● 环境原因, 高温环境下电池寿命变短, 更换新电池。</li><li>● 运营商有关, 信号微弱地区耗电增加, 请暂时将对讲机关闭。</li></ul>
无法连接网络	<ul style="list-style-type: none"><li>● SIM卡无法正常工作或无法使用, SIM有欠费, 确认SIM卡余额使用或付费。</li><li>● 手机网络未启用, 打开SIM卡网络, 联系运营商启用蜂窝网络。</li></ul>

Can't Connect to Network	The SIM card cannot work properly or cannot be used. - Make sure the SIM card has a balance instead of arrears.
	The mobile network not available. - Select SIM card network, and contact the operator to activate the cellular network.
	In areas with poor signal, out of network service, or SIM card is not effective. - Remove the SIM cards, and reinsert them properly, or change another one. Move to somewhere with better network signal or go to the window if you are in the building.

## Specification

OS	Android 8.1
Frequency	GSM:850/900/1800/1900
	WCDMA:850/900/1900/2100/1700
	FDD:B1/B2/B3/B4/B5/B7/B8/B17/B20/B28AB
	TDD:B34/B38/B39/B40/B41
CPU	MT6762 Octa-core 2.0GHz processor
Memory	RAM 2GB+ROM 16GB(ROM)
Working Voltage	3.8
Display	3.1inch, 480x800
Camera	Front Camera: 5.0MP Rear Camera: 13.0MP Wide-angle Camera: 4.0MP
Viewing Angle	117 °
Support	WiFi BT NFC LTE
	BDS GPS AGPS GLOONASS
Dimension (H*W*D)	102.7*62.4*26.5mm
Weight	≈ 175g (without belt clip)
Working Temperature	-20°C +55°C
Storage Temperature	-40°C ~ +70°C

存储温度	-40°C ~ +70°C
工作温度	-20°C +55°C
重量	≈ 175g (不含背夹)
尺寸	102.7*62.4*26.5mm
支持	北斗 GPS AGPS GLOONASS
	WiFi BT NFC
视角	117 °
摄像头	前置500万 后置1300万 广角摄像头400万
屏幕尺寸	3.1英寸 480x800(屏幕分辨率)
工作电压	3.8V
内存	RAM 2GB+ROM 16GB
CPU	MT6762 /核2.0GHz处理器
频段	TDD:B34/B38/B39/B40/B41
	FDD:B1/B2/B3/B4/B5/B7/B8/B17/B20/B28AB
	WCDMA:850/900/1900/2100/1700
	GSM:850/900/1800/1900
操作系统	Android 8.1

## Network Connecting

### 1.WIFI Connecting

Turn on the device, click "Settings", touch and hold , make sure Wi-Fi is turned on. Select the wireless network and enter the password to connect.

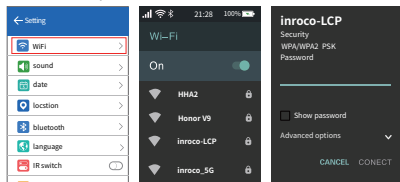

### 2.Cellular Network Connecting

Open "Settings", tap on 'Cellular Network', select the one that you need to connect.

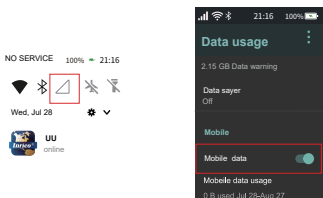

### Stop Running Non-systematic APP

Select "Settings" → Apps → Confirm the APP required → FORCE STOP

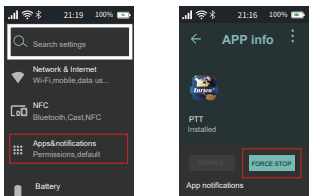

## Basic Troubleshooting

If your device shows following problem during operating, please check the instruction as below. If problems can't be solved, please contact local authorized service.

Problems	Solutions
Unable to Power On	The battery may be incorrectly installed. - Re-attaching the battery.
	The battery maybe out of power. - Charge or replace the battery.
	The battery may be in poor contact due to dirty or damage. - Clean the electrical contact or replace it.
Terminal Crash	Too much APPS on processing. - Force some programs to quit or restart the terminal.
Buttons Not Working	The buttons may not work temporarily, restart the terminal.
	The buttons is broken, contact the dealer or our company.
White Screen Error	Display screen may not work temporarily, restart the device. The display screen is damaged, contact the dealer or our company.
Echo or Noise During Connecting	The signal may be weak, make sure the terminal is within network coverage. - Restart the radio and it'll automatically search for better available network.
	The speaker may be covered, clean the speaker surface.
Unable to Locate	The signal is weak and the radio can't receive the signal. - Move to open and flat area and try again.
Unable to Detect SIM Card	The SIM card may be incorrectly installed. - Remove and re-insert the SIM card.
	Localized poor coverage due to basement, blocking buildings or destructive interference, and geographical distance from obstacles between your radio and the nearest cell tower. - Please move to somewhere with improved signal.
Poor Reception	Localized network is busy during rush hours. - Please wait for a while before another attempt or try to avoid using in rush hours.
	The SIM card may be not working due to dirt or damage. - Clean the electrical contact or replace it.
Unable to Charge	The power adapter plug may be damaged or poor contacting. - Pull out and re-plug the adapter.
	The charging cable connectors may be damaged or poor contact. - Pull out and re-insert the cable.
Less Duration	The duration mostly depends on network service provider settings.
Shorter Standby Time	The battery life becomes shorter in high temperature environment. - Replace a new qualified battery.
	Power consumption increased in areas with weak signal. - Please temporarily turn off the device.

## Basic functions

### 1. Powering Up and Powering Off the Device

- Power On: Long press the power button for 3 seconds and the program will start.
- Power Off: Long press the power button for 3 seconds. If the device is on charging, indicators will be in red and display the current battery level.

### 2. User Log-in

After the user log in successfully, user ID will be broadcast.

### 3. Initiate a Call

- Press PTT button and start to talk.
- The LED light is solid red during transmitting and receiving.
- The LED light is solid green during idle state.
- The call ends automatically once it lasts more than 60 seconds, which could be set to 1-60 seconds by APP.

### 2. Night Vision Mode

Night mode automatically turns on when the camera detects a low-light environment.

## Status Indicators

LED Indicator	Working Status	Remark
Blinking Red	Low power less than 15%	Flash 3S/time
Solid Red	The device is transmitting.	
	The device is calling.	
	The device is charging.	
Solid Green	Normal standby	
	Fully charged	

## Operating Instructions

### Operation Interface

**Preview Interface:** Turn on the device and show the preview interface. Press the "return virtual-key" to enter the main interface.



**Function Menus:** There are 6 function menus in the main interface, click the corresponding menu to access related functions.

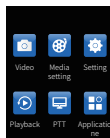

**Setting:** GPS, WIFI, Bluetooth, Language, Time and Date, Night Vision Mode, etc.

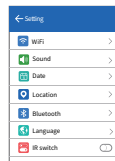

**Multimedia Playback:** view videos, pictures and recordings.



## Accessories Installation

### 1.Insert NANO-size SIM card.

Insert SIM card to the the SIM card slot on the left of the device.

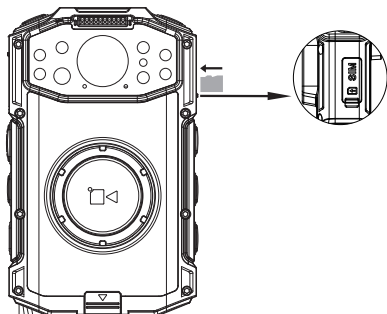

### 2.Attaching/ Removing the Belt Clip

- Align the belt clip with the grooves on the device, insert, rotate 90°clockwise and tighten it.
- Rotate 90°counterclockwise to remove the belt clip.

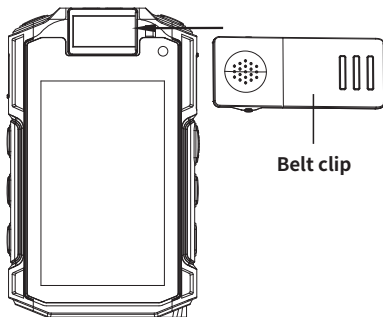

### 3.Attaching/ Removing the Shoulder Clip

- Align the shoulder clip with the grooves on the device, press it downwards until it clicks.
- Touch the plectrum to pull out the shoulder clip.

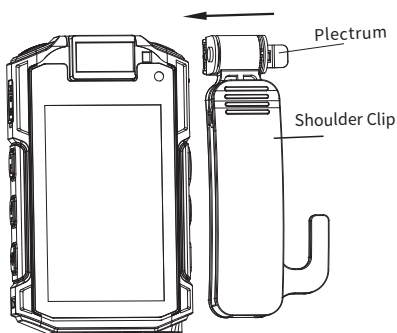

### 4.Attaching/ Removing the Shoulder Clip



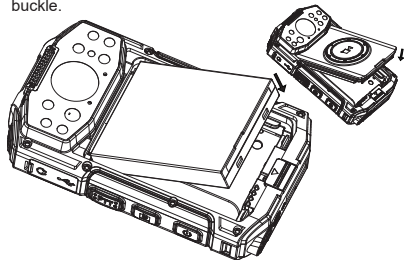

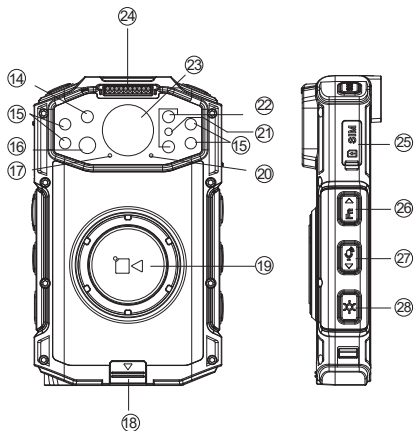



- Touch the cover plectrum and remove the battery cover buckle.
- Align the electrical contact of the battery with the bottom rails.
- Press the battery firmly, make sure the electrical connection touch with the bottom.
- Close the battery cover and lock the battery cover buckle.





1	Earpiece/ USB Interface	15	Infrared Light
2	PTT	16	Rear Camera
3	Take Photo Button	17	Status Indicator
4	Power Button	18	Battery Fixed Buckle
5	Front Camera	19	Video Record Button
6	Screen	20	MIC
7	Charging Interface	21	Light Sensor
8	Rotary Knob	22	Flashlight
9	Microphone	23	Wide-angle Camera
10	Video Record Button	24	Warning Light
11	Status Indicator	25	SIM Card
12	Speaker	26	Volume+
13	SOS Button	27	Recording/ Volume-
14	Laser Light	28	Light

## Basic Functions

Button	Name	Description
	SOS Button	<ul style="list-style-type: none"> <li>• Long press to notify the command center and upload video to the server automatically.</li> <li>• Short press to mark the video as important.</li> </ul>
	Video Record Button	Press the video button to record video, short press to stop during recording.
	Volume+ Button	Press volume+ button to increase the volume.
	Audio Recording/Volume- Button	<ul style="list-style-type: none"> <li>• Press the recording button to start recording, and long press to stop.</li> <li>• Short press to reduce the volume.</li> </ul>
	Light Button	<ul style="list-style-type: none"> <li>• Long press to start alarm light flashing, long press again to turn it off.</li> <li>• Double-click quickly to start the laser lamp, double click again to turn it off.</li> <li>• Short press to turn on or turn off night shooting.</li> </ul>
	PTT Button	Press the PTT button to call and release it to listen. Remark: This function requires the permission from the command center.
	Camera Button	<ul style="list-style-type: none"> <li>• Short press to take a picture.</li> <li>• Long press to turn on flashlight.</li> </ul>
	Power Button	<ul style="list-style-type: none"> <li>• When the device is power off, long press 2s to start.</li> <li>• When the device is power on, press to select shutdown or restart options as prompted.</li> <li>• Long press 8s to restart the system forcibly.</li> </ul>

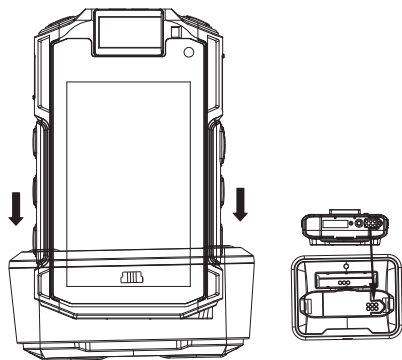

### USB Charging

Align the micro USB cable with the device and insert to the power adaptor. The LED indicator will light up during charging.

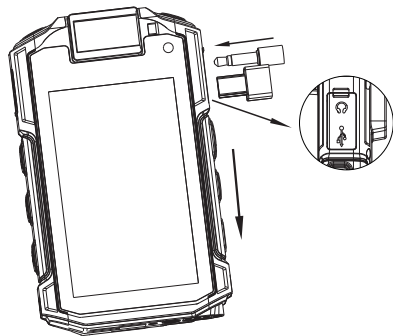

### Product Overview

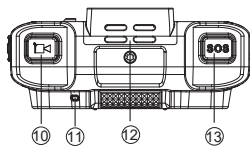
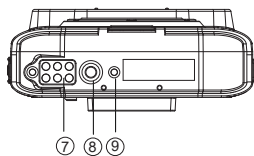
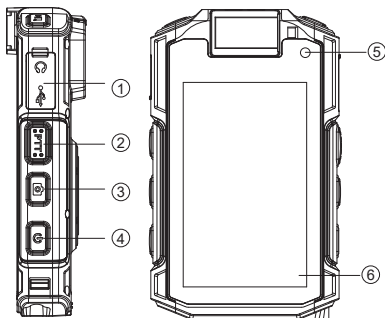

## Handling Precautions

### ※ Do not overcharge the battery

Please stop charging if it can't be fully charge within required time. The battery probably overheats, smokes, bursts or suddenly be on fire due to abnormal charging process.

### ※ Do not discard battery in a fire, microwave or high pressure container.

The battery probably overheats, smokes, bursts or suddenly be on fire.

### ※ Do not expose damaged battery near any fire.

If the battery is broken, leaking or with an abnormal odor, please remove it from flammable areas immediately. The fluid in the battery is flammable, which may cause smoke and fire.

### ※ Do not use abnormal battery

If the battery is with odd smelly, discolored, deformed, etc., please stop charging immediately.

### ※ Please use authorized power adaptor

To comply with warranty terms and avoid damages, charge the battery using a specified charger for best performance.

### ※ Desktop charging

The desktop charger must be away from the flammable places. Please make sure the radio working properly and without any damage while charging, do not put the radio into the charger's socket if no need of charging.

## Battery Care

### Fully Charge Battery Before Initial Use

- Do preserve battery life by switching off a device and removing the batteries when it's not being used, and is not expected to be used for extended periods of time.
- Do practice proper battery storage by keeping batteries in a cool, dry place at normal room temperature.

### Properly Store Batteries

- Remove the battery from the device.
- Charge and discharge the battery to 40%-65% if it will not be used for 10 days or more. This can greatly extend the battery life.
- The battery should drop below 65% when it is idle for more than 10 days to prevent it from swelling.
- d. Store the battery in cool and dry environment that's less than 25°C.

### Features of Lithium Battery

- Battery capacity will reduce after multiple charging cycles.
  - The battery capacity drops gradually even without being used.
  - Longer charging time is required in shady place.
  - Charging and storing Lithium battery in warm condition will short its lifespan. Please do not leave them inside the vehicle or near the heater.
- e.If the battery working time has reduced significantly, please replace the battery immediately in avoidance of fluid leakage.

### Lithium Battery Charging

- Connect the device with an AC adapter, power on, the LED turns to red.
- The LED shows green of fully charged.
- The LED is off under high operating temperature, poor contact, or battery damage.

## Charging

### Desktop Charger

- When using the charger, please place it on a flat surface away from flammable materials.
- Please put it into the desktop charger port as to the instruction diagram, and make sure the device is safe during charging.
- Please do not place it into the desktop charger when not charging.



## Contents

Unboxing and Device Checking.....	01
Handling Precautions.....	01
Battery Care.....	02
Fully Charge Battery Before Initial Use.....	03
Properly Store Batteries.....	03
Features of Lithium Battery.....	03
Lithium Battery Charging.....	03
Product Overview.....	05
Accessories Installation.....	07
Insert SIM Card.....	08
Attaching the Belt Clip.....	08
Attaching the Shoulder Clip.....	09
Attaching the Battery.....	09
Basic Functions.....	10
Powering Up and Powering Off.....	10
User Log-in.....	10
Initiate a Call.....	10
Night Vision Mode.....	10
Status Indicators.....	10
Operating Instructions.....	11
Operation Interface.....	12
Network Connecting.....	12
Wireless Network Connecting.....	12
Cellular Network Connecting.....	12
Stop Running Non-systematic APP.....	12
Basic Troubleshooting.....	13
Specification.....	14

## Unpacking and Device Checking

Please unbox and take out the device and all accessories carefully, and ensure all lists have been gotten before discarding the cardboard box. If any items are lost or damaged in transit, please contact with our distributors.

Items	Number
Body Worn Camera	1
Lithium Battery	1
Power Adaptor	1
USB Charging Cable	1
Shoulder Clip	1
Belt Clip	1
Charger	1
User Manual	1

## Disclaimer

This guide is for reference only and the information in this document is carefully examined, and is believed to be entirely reliable. However, no responsibility is assumed for inaccuracies. Furthermore, Inrico reserves the right to make changes to any products herein to improve readability, function, or design. Inrico does not assume any liability arising out of the applications or use of any product or circuit described herein; nor does it cover any license under its patent rights, nor the rights of others.

## Notes Before Using

Please read the following content carefully. It is very important for radio users to gain general knowledge and risks.

- Do not use the device or charging the battery in any hazardous areas such as gas, dust, steam, etc.
- Please turn off the device while refueling or parking at the gas station.
- Do not disassemble your radio.
- Avoid prolonged time in the sun or placing it near heating appliance.
- Avoid excessive exposure to the extreme dusty, damp and splashing place, or leave it on unstable surface.
- Changes or modifications made to this device, not expressly approved by Inrico, could void the user's authority to operate this equipment.
- Reparation by professional technicians, do not disassemble by yourself.

**FCC Caution:**

Any Changes or modifications not expressly approved by the party responsible for compliance could void the user's authority to operate the equipment.

This device complies with part 15 of the FCC Rules.

Operation is subject to the following two conditions:

(1) This device may not cause harmful interference, and (2) this device must accept any interference received, including interference that may cause undesired operation.

**IMPORTANT NOTE:**

Note: This equipment has been tested and found to comply with the limits for a Class B digital device, pursuant to part 15 of the FCC Rules. These limits are designed to provide reasonable protection against harmful interference in a residential installation. This equipment generates, uses and can radiate radio frequency energy and, if not installed and used in accordance with the instructions, may cause harmful interference to radio communications. However, there is

no guarantee that interference will not occur in a particular installation. If this equipment does cause harmful interference to radio or television reception, which can be determined by turning the equipment off and on, the user is encouraged to try to correct the interference by one or more of the following measures:

- Reorient or relocate the receiving antenna.
- Increase the separation between the equipment and receiver.
- Connect the equipment into an outlet on a circuit different from that to which the receiver is connected.
- Consult the dealer or an experienced radio/TV technician for help.

**FCC Radiation Exposure Statement:**

The device has been tested and comply with FCC SAR limits

#### Body-worn operating

This device was tested for typical body-worn with belt-clips operations. To comply with RF exposure requirements, a minimum separation distance of 1.0 cm must be maintained between the user's body and the other side of product.