



东莞市友亿线圈电子科技有限公司

Dongguan Youyi Coil Electronic Technology Co., Ltd

产品规格承认书

Specificaton Approval

客户名称 (Customer) : Powerstick.com Inc.

客户料号 (Customer P/N) : _____

产品类型 (Model) : MagStand

发行日期 (Issue Date) : _____

文件版本 (Document Rev.) : _____

客户签署
(Customer Signatures)

初审 (Precheck By) :	复审 (Checked By) :	承认 (Approved By) :

敬请签回。如未签回，下订单等同已承认签回！

我司签署
(Inner Signatures)

部门 (Department) :	工程部 (ED)	品质部 (QC)	业务部 (SD)
核实 (Approvde By) :	黄彬	朱东明	李水安

制作商 (Mfrs.) : Dongguan Youyi Coil Electronic Technology Co., Ltd

地址 (Add.) : 4th Floor, No. 57 Bitao Street, Shijie Town, Dongguan City, Guangdong, China

电话 (Tel) : +86-13415878813

邮箱 (E-mail) : 531120064@qq.com

产品型号: Model Number	单层单槽发射带孔模组	客户料号: Customer P / N	
		供应商料号: Supplier P / N	

一, 外观与尺寸 (Appearance Size) : (单位/mm)

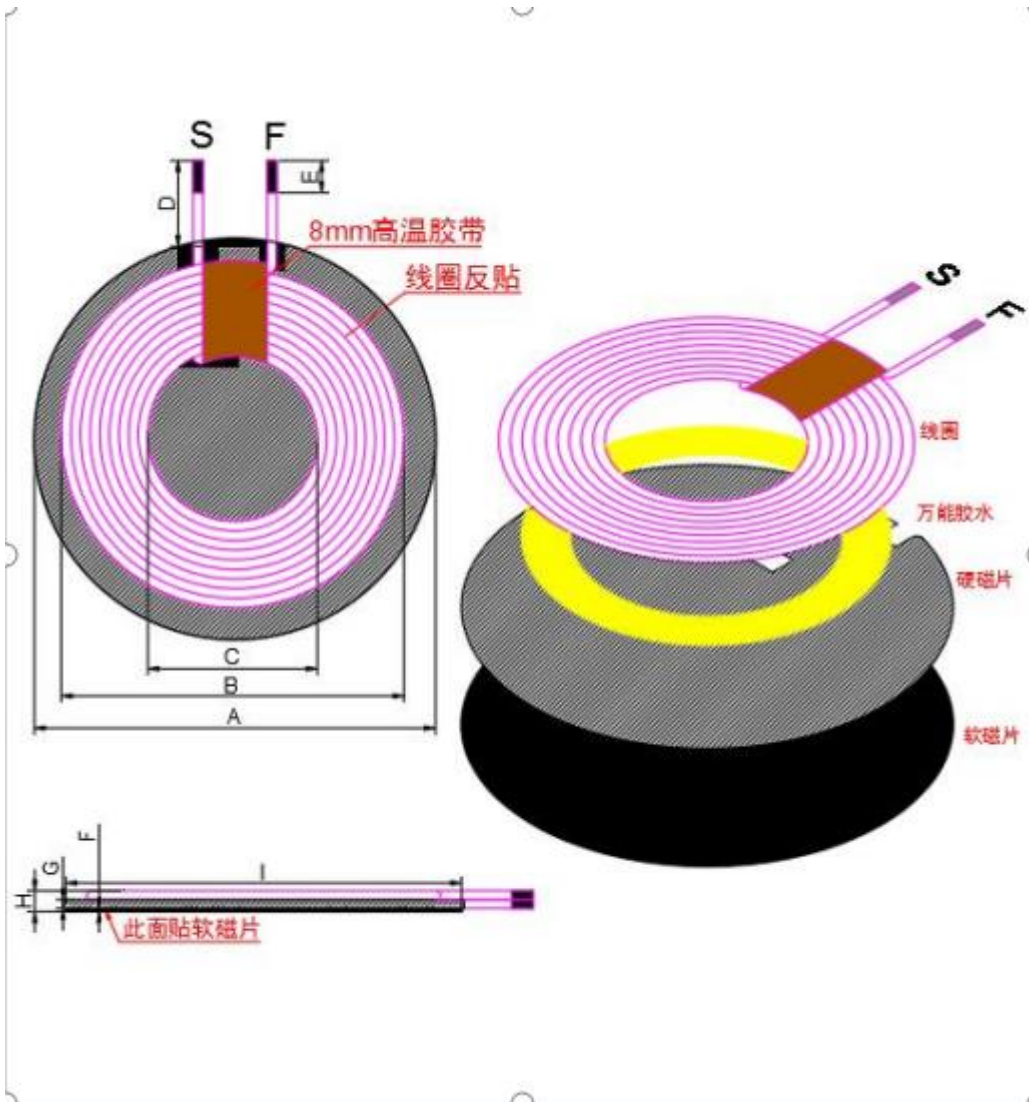

A	40±0.5
B	20.5±0.5
C	39±1
D	180±2
E	3±1
F	4MAX
G	1.0±0.3
H	3.0MAX
I	
J	
K	
L	
M	
N	
O	
P	
Q	
R	
S	
T	
U	
V	
W	
X	
Y	
Z	

We statement that All measurements were performed radiated and therefore additional antenna gain documentation is not required.

二，原理图（Schematic Diagram）：

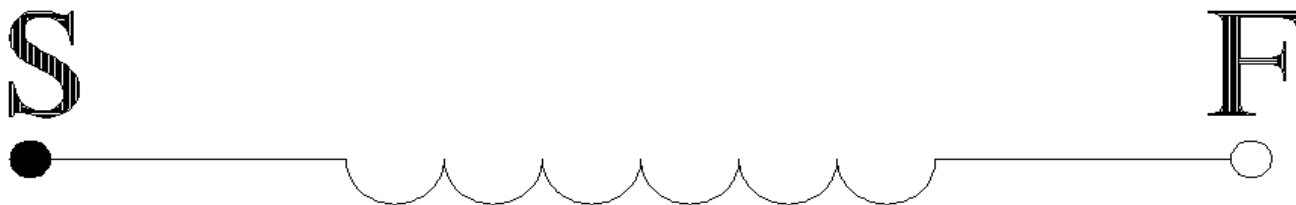

三，绕线参数（Winding Parameters）：

绕组 Winding	开始 Start	结束 Finish	圈数 Turns	线径 Line Diameter	绕线方式 Winding Way	绕线方向 Winding Direction	层数&圈数 Layer&Circle
	S	F	12TS	0.08*60P	单层密绕	逆时针	1层/12TS

四，电气特性（Electrical Characteristics）：

项目 Item	端子 Terminal	测试条件 Test Conditions	测试仪器 Test Instrument	参数 Parameter	单位 Unit	数值 Numerical Value
电感	S-F	100KHz/1.00V/100Ω	1062 电桥	Inductance @100KHz/1V	μH	10μH±10%
Q 值	S-F	100KHz/1.00V/100Ω	1062 电桥	Q@100KHz/1V		20MIN
电阻	S-F	100KHz/1.00V/100Ω	1062 电桥	RS@100KHz/1V	mΩ	160MAX

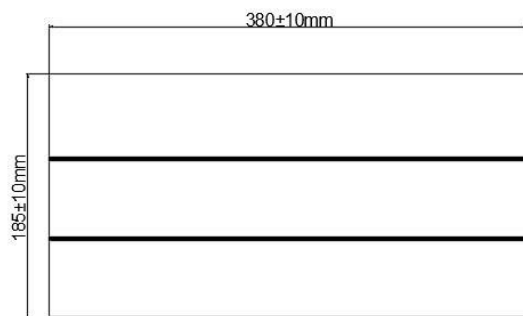
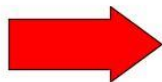
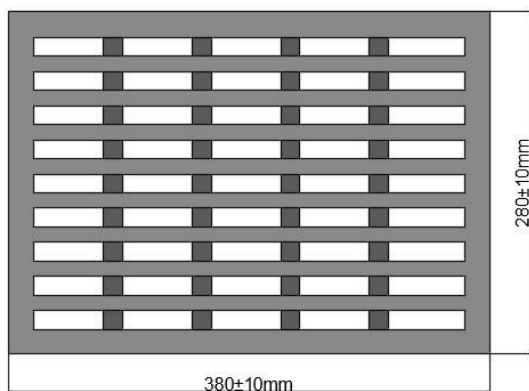

每箱装3层珍珠棉，珍珠棉之间用纸板隔开

珍珠棉尺寸为：38*28*6cm，
每个珍珠棉有45格，每格装6pcs共270pcs产品。

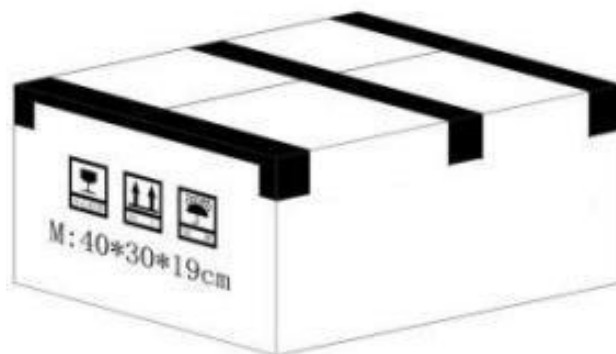

- 1、每层珍珠棉可装 270pcs 产品；
- 2、每箱可装 3 层珍珠棉，即可装 810 产品

产品 Product	单层数量 Single layer quantity	层数/箱 Layer/Box	总数/箱 Total/Box	重量 Weigh
A11	270pcs	3 层	810pcs	

材料清单

Material List

客户料号: Customer P / N		制造商料号: Supplier P / N		
序号 No.	材料名称 Material Name	材料规格 Material Specification	材料代号 Material Code	制造商 Manufacturer
1	自粘丝包线	0.08*60P	XCSBX-00080105-0001	
2	无铅锡条	高温	WQXT*-33002420-0013	
3	胶水	树脂胶	WNJS*-00000015-0021	
4	高温胶带	8mm	GWJD*-18000005-0010	
5	G40 磁片	G40*5.3*1mm	CP**Y-50005310-0018	
6	双面胶	39.5*5.5*0.08mm	SMJ**-49505508-0003	
7	纸箱	400*305*190mm	ZH***-40030519-0015	
8				
9				
10				
11				
12				
13				
14				