



FCC Part 15C Test Report

FCC ID: 2AITMDS830

Product Name:	DS830
Trademark:	N/A
Model Name :	DS830 DS831,DS832,DS836
Prepared For :	Shenzhen Smart Device Technology Co., LTD
Address :	SSMEC Building,Gao Xin Nan First Avenue Hi-Tech Park South,Nanshan,Shenzhen,China
Prepared By :	Shenzhen BCTC Technology Co., Ltd.
Address :	No.101,Yousong Road,Longhua New District, Shenzhen,China
Test Date:	Jun. 3–Jun. 14, 2016
Date of Report :	Jun. 14, 2016
Report No.:	BCTC-160606861E



TEST RESULT CERTIFICATION

Applicant's name : Shenzhen Smart Device Technology Co., LTD
Address : SSMEC Building,Gao Xin Nan First Avenue Hi-Tech Park
South,Nanshan,Shenzhen,China

Manufacturer's Name..... : Shenzhen Smart Device Technology Co., LTD
Address : SSMEC Building,Gao Xin Nan First Avenue Hi-Tech Park
South,Nanshan,Shenzhen,China

Product description

Product name : DS830
Trademark : N/A
Model and/or type reference : DS830
DS831,DS832,DS836

Standards : FCC Part15.247
ANSI C63.10:2013
KBD 558074 D01 DTS Meas Guidance v03r05

This device described above has been tested by BCTC, and the test results show that the equipment under test (EUT) is in compliance with the FCC requirements. And it is applicable only to the tested sample identified in the report.

This report shall not be reproduced except in full, without the written approval of BCTC, this document may be altered or revised by BCTC, personal only, and shall be noted in the revision of the document.

Testing Engineer : Eric Yang
Eric Yang

Reviewer (Supervisor) : Jade Yang
Jade Yang

Approved & Authorized Signer(Manager) : Carson Zhang
Carson Zhang





Table of Contents		Page
1 . SUMMARY OF TEST RESULTS		5
1.1 TEST FACILITY		6
1.2 MEASUREMENT UNCERTAINTY		6
2 . GENERAL INFORMATION		7
2.1 GENERAL DESCRIPTION OF EUT		7
2.2 DESCRIPTION OF TEST MODES		8
2.3 BLOCK DIGRAM SHOWING THE CONFIGURATION OF SYSTEM TESTED		9
2.4 DESCRIPTION OF SUPPORT UNITS(CONDUCTED MODE)		9
2.5 EQUIPMENTS LIST FOR ALL TEST ITEMS		10
3 . EMC EMISSION TEST		11
3.1 CONDUCTED EMISSION MEASUREMENT		11
3.1.1 POWER LINE CONDUCTED EMISSION LIMITS		11
3.1.2 TEST PROCEDURE		11
3.1.3 DEVIATION FROM TEST STANDARD		11
3.1.4 TEST SETUP		12
3.1.5 EUT OPERATING CONDITIONS		12
3.1.6 TEST RESULTS		12
3.2 RADIATED EMISSION MEASUREMENT		15
3.2.1 RADIATED EMISSION LIMITS		15
3.2.2 TEST PROCEDURE		16
3.2.3 DEVIATION FROM TEST STANDARD		16
3.2.4 TEST SETUP		16
3.2.5 EUT OPERATING CONDITIONS		17
3.2.6 TEST RESULTS (BETWEEN 9KHZ – 30 MHZ)		18
3.2.7 TEST RESULTS (BETWEEN 30MHZ – 1GHZ)		19
3.2.8 TEST RESULTS (1GHZ~25GHZ)		21
3.3 RADIATED BAND EMISSION MEASUREMENT		29
3.3.1 TEST REQUIREMENT:		29
3.3.2 TEST PROCEDURE		29
3.3.3 DEVIATION FROM TEST STANDARD		30
3.3.4 TEST SETUP		30
3.3.5 EUT OPERATING CONDITIONS		30
4 . POWER SPECTRAL DENSITY TEST		35
4.1 APPLIED PROCEDURES / LIMIT		35



Table of Contents		Page
4.1.1 TEST PROCEDURE		35
4.1.2 DEVIATION FROM STANDARD		35
4.1.3 TEST SETUP		35
4.1.4 EUT OPERATION CONDITIONS		35
4.1.5 TEST RESULTS		36
5 . BANDWIDTH TEST		44
5.1 APPLIED PROCEDURES / LIMIT		44
5.1.1 TEST PROCEDURE		44
5.1.2 DEVIATION FROM STANDARD		44
5.1.3 TEST SETUP		44
5.1.4 EUT OPERATION CONDITIONS		44
5.1.5 TEST RESULTS		45
6 . PEAK OUTPUT POWER TEST		53
6.1 APPLIED PROCEDURES / LIMIT		53
6.1.1 TEST PROCEDURE		53
6.1.2 DEVIATION FROM STANDARD		53
6.1.3 TEST SETUP		53
6.1.4 EUT OPERATION CONDITIONS		53
6.1.5 TEST RESULTS		54
7 . 100 KHZ BANDWIDTH OF FREQUENCY BAND EDGE		55
7.1 APPLICABLE STANDARD		55
7.2 TEST PROCEDURE		55
7.3 DEVIATION FROM STANDARD		55
7.4 TEST SETUP		55
7.5 EUT OPERATION CONDITIONS		55
7.1 TEST RESULTS		55
8 . ANTENNA REQUIREMENT		60
8.1 STANDARD REQUIREMENT		60
8.2 EUT ANTENNA		60
9 . EUT TEST PHOTO		61
10 . EUT PHOTO		63
APPENDIX-PHOTOGRAPHS OF EUT CONSTRUCTIONAL DETAILS		



1. SUMMARY OF TEST RESULTS

Test procedures according to the technical standards:

FCC Part15 (15.247) , Subpart C			
Standard Section	Test Item	Judgment	Remark
15.207	Conducted Emission	PASS	
15.247 (a)(2)	6dB Bandwidth	PASS	
15.247 (b)	Peak Output Power	PASS	
15.247 (c)	Radiated Spurious Emission	PASS	
15.247 (d)	Power Spectral Density	PASS	
15.205	Band Edge Emission	PASS	
15.203	Antenna Requirement	PASS	

NOTE:

(1) "N/A" denotes test is not applicable in this Test Report



1.1 TEST FACILITY

Shenzhen BCTC Technology Co., Ltd.

Add. : No.101, Yousong Road, Longhua New District, Shenzhen, China

FCC Registered No.: 187086

1.2 MEASUREMENT UNCERTAINTY

The reported uncertainty of measurement $y \pm U$, where expanded uncertainty U is based on a standard uncertainty multiplied by a coverage factor of $k=2$, providing a level of confidence of approximately **95 %**.

No.	Item	Uncertainty
1	Conducted Emission Test	$\pm 1.38\text{dB}$
2	RF power, conducted	$\pm 0.16\text{dB}$
3	Spurious emissions, conducted	$\pm 0.21\text{dB}$
4	All emissions, radiated (<1G)	$\pm 4.68\text{dB}$
5	All emissions, radiated (>1G)	$\pm 4.89\text{dB}$
6	Temperature	$\pm 0.5^\circ\text{C}$
7	Humidity	$\pm 2\%$



2. GENERAL INFORMATION

2.1 GENERAL DESCRIPTION OF EUT

Equipment	DS830	
Trade Name	N/A	
Model Name	DS830 DS831,DS832,DS836	
Model Difference	The product's different for model number and outlook color.	
Product Description	The EUT is a DS830	
	Operation Frequency:	802.11b/g/n20MHz:2412~2462 MHz 802.11n40MHz:2422~2452 MHz
	Modulation Type:	WIFI: OFDM/DSSS
	Bit Rate of Transmitter	802.11b:11/5.5/2/1 Mbps 802.11g:54/48/36/24/18/12/9/6Mbps 802.11n Up to 150Mbps
	Number Of Channel	802.11b/g/n20MHz:11 CH 802.11n40MHz: 7 CH
	Antenna Designation:	Please see Note 3.
Based on the application, features, or specification exhibited in User's Manual, the EUT is considered as an ITE/Computing Device. More details of EUT technical specification, please refer to the User's Manual.		
Channel List	Please refer to the Note 2.	
Power	DC 12V from adapter	
Adapter	Model:JK-120200-S07CN I/P: AC 100-240V 50/60Hz O/P: DC 12V 2A	
hardware version	--	
Software version	--	
Serial number	--	
Connecting I/O Port(s)	Please refer to the User's Manual	

Note:

1. For a more detailed features description, please refer to the manufacturer's specifications or the User's Manual.



2.

Channel List for 802.11b/g/n(20)							
Channel	Frequency (MHz)	Channel	Frequency (MHz)	Channel	Frequency (MHz)	Channel	Frequency (MHz)
01	2412	04	2427	07	2442	10	2457
02	2417	05	2432	08	2447	11	2462
03	2422	06	2437	09	2452		

Channel List for 802.11n(40)							
Channel	Frequency (MHz)	Channel	Frequency (MHz)	Channel	Frequency (MHz)	Channel	Frequency (MHz)
03	2422	05	2432	07	2442	09	2452
04	2427	06	2437	08	2447		

3.

Table for Filed Antenna

Ant.	Brand	Model Name	Antenna Type	Connector	Gain (dBi)	NOTE
1	N/A	N/A	external antenna		5.0	

2.2 DESCRIPTION OF TEST MODES

Pretest Mode	Description
Mode 1	802.11b CH1/ CH6/ CH11
Mode 2	802.11g CH1/ CH6/ CH11
Mode 3	802.11n20 CH1/ CH6/ CH11
Mode 4	802.11n40 CH3/ CH6/ CH9
Mode 5	Link Mode

Conducted Emission	
Final Test Mode	Description
Mode 5	Link Mode

For Radiated Emission	
Final Test Mode	Description
Mode 1	802.11b CH1/ CH6/ CH11
Mode 2	802.11g CH1/ CH6/ CH11
Mode 3	802.11n20 CH1/ CH6/ CH11
Mode 4	802.11n40 CH3/ CH6/ CH9

Note:

(1) The measurements are performed at all Bit Rate of Transmitter, the worst data was reported.

2.3 BLOCK DIGRAM SHOWING THE CONFIGURATION OF SYSTEM TESTED

Radiated Spurious Emission Test

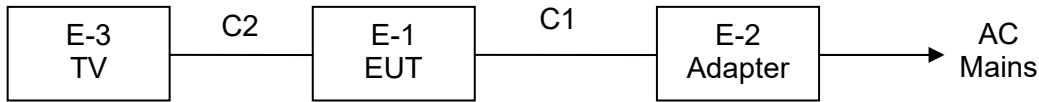

Conducted Emission Test

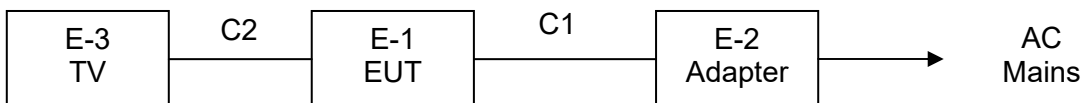

2.4 DESCRIPTION OF SUPPORT UNITS(CONDUCTED MODE)

The EUT has been tested as an independent unit together with other necessary accessories or support units. The following support units or accessories were used to form a representative test configuration during the tests.

Item	Equipment	Mfr/Brand	Model/Type No.	Series No.	Note
E-1	DS830	N/A	DS830	N/A	EUT
E-2	Adapter	N/A	JK-120200-S07CN		Provide by test lab
E-3	TV	SONY	MNT1		Provide by test lab

Item	Shielded Type	Ferrite Core	Length	Note
C1	No	No	1.2m	DC Line
C2	No	No	0.8m	HDMI Line

Note:

- (1) The support equipment was authorized by Declaration of Confirmation.
- (2) For detachable type I/O cable should be specified the length in cm in 『Length』 column.



2.5 EQUIPMENTS LIST FOR ALL TEST ITEMS

Radiation Test equipment

Item	Kind of Equipment	Manufacturer	Type No.	Serial No.	Last calibration	Calibrated until
1	Spectrum Analyzer	Agilent	E4407B	MY4510957 2	2015.08.25	2016.08.24
2	Test Receiver	R&S	ESPI	101396	2015.08.25	2016.08.24
3	Bilog Antenna	SCHWARZB ECK	VULB9160	VULB9160- 3369	2015.08.25	2016.08.24
4	50Ω Coaxial Switch	Anritsu	MP59B	620026441 6	2015.07.06	2016.07.05
5	Spectrum Analyzer	Agilent	N9020A	MY5051041	2015.07.06	2016.07.05
6	Horn Antenna	SCHWARZB ECK	9120D	9120D-1275	2015.08.25	2016.08.24
7	Horn Ant	Schwarzbeck	BBHA 9170	9170-181	2015.07.06	2016.07.05
8	Amplifier	SCHWARZB ECK	BBV9718	9718-270	2015.08.25	2016.08.24
9	Amplifier	SCHWARZB ECK	BBV9743	9743-119	2015.08.25	2016.08.24
10	Loop Antenna	ARA	PLDS83030 /B	1029	2015.07.06	2016.07.05
11	Power Meter	R&S	NRVS	100696	2015.07.06	2016.07.05
12	Power Sensor	R&S	URV5-Z4	0395.1619. 05	2015.07.06	2016.07.05
13	RF cables	R&S	N/A	N/A	2015.07.06	2016.07.05

Conduction Test equipment

Item	Kind of Equipment	Manufacturer	Type No.	Serial No.	Last calibration	Calibrated until
1	Test Receiver	R&S	ESCI	1166.5950K 03-101165- ha	2015.08.25	2016.08.24
2	LISN	R&S	NSLK81 26	812646 6	2015.08.25	2016.08.24
3	LISN	R&S	NSLK81 26	812648 7	2015.08.25	2016.08.24
4	50Ω Coaxial Switch	Anritsu	MP59B	620026441 7	2015.08.25	2016.08.24
5	RF cables	R&S	R204	R20X	2015.08.25	2016.08.24



3. EMC EMISSION TEST

3.1 CONDUCTED EMISSION MEASUREMENT

3.1.1 POWER LINE CONDUCTED EMISSION Limits (Frequency Range 150KHz-30MHz)

FREQUENCY (MHz)	Class A (dBuV)		Class B (dBuV)		Standard
	Quasi-peak	Average	Quasi-peak	Average	
0.15 -0.5	79.00	66.00	66 - 56 *	56 - 46 *	FCC
0.50 -5.0	73.00	60.00	56.00	46.00	FCC
5.0 -30.0	73.00	60.00	60.00	50.00	FCC

Note:

- (1) The tighter limit applies at the band edges.
- (2) The limit of " * " marked band means the limitation decreases linearly with the logarithm of the frequency in the range.

The following table is the setting of the receiver

Receiver Parameters	Setting
Attenuation	10 dB
Start Frequency	0.15 MHz
Stop Frequency	30 MHz
IF Bandwidth	9 kHz

3.1.2 TEST PROCEDURE

- a. The EUT was placed 0.8 meters from the horizontal ground plane with EUT being connected to the power mains through a line impedance stabilization network (LISN). All other support equipments powered from additional LISN(s). The LISN provide 50 Ohm/ 50uH of coupling impedance for the measuring instrument.
- b. Interconnecting cables that hang closer than 40 cm to the ground plane shall be folded back and forth in the center forming a bundle 30 to 40 cm long.
- c. I/O cables that are not connected to a peripheral shall be bundled in the center. The end of the cable may be terminated, if required, using the correct terminating impedance. The overall length shall not exceed 1 m.
- d. LISN at least 80 cm from nearest part of EUT chassis.
- e. For the actual test configuration, please refer to the related Item –EUT Test Photos.

3.1.3 DEVIATION FROM TEST STANDARD

No deviation

3.1.4 TEST SETUP

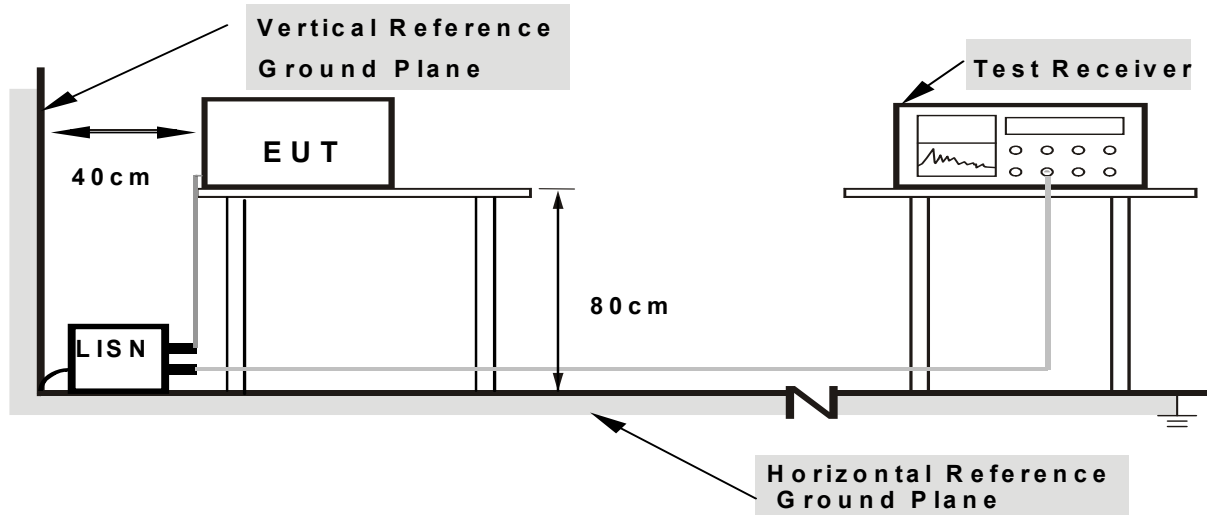

Note: 1. Support units were connected to second LISN.

2. Both of LISNs (AMN) are 80 cm from EUT and at least 80 cm from other units and other metal planes

3.1.5 EUT OPERATING CONDITIONS

The EUT was configured for testing in a typical fashion (as a customer would normally use it). The EUT has been programmed to continuously transmit during test. This operating condition was tested and used to collect the included data.

We pretest AC 120V and AC 240V, the worst voltage was AC 120V and the data recording in the report.

3.1.6 TEST RESULTS



Temperature :	25 °C	Relative Humidity :	54%
Pressure :	1010hPa	Phase :	L
Test Voltage :	AC 120V/60Hz	Test Mode :	Mode 5

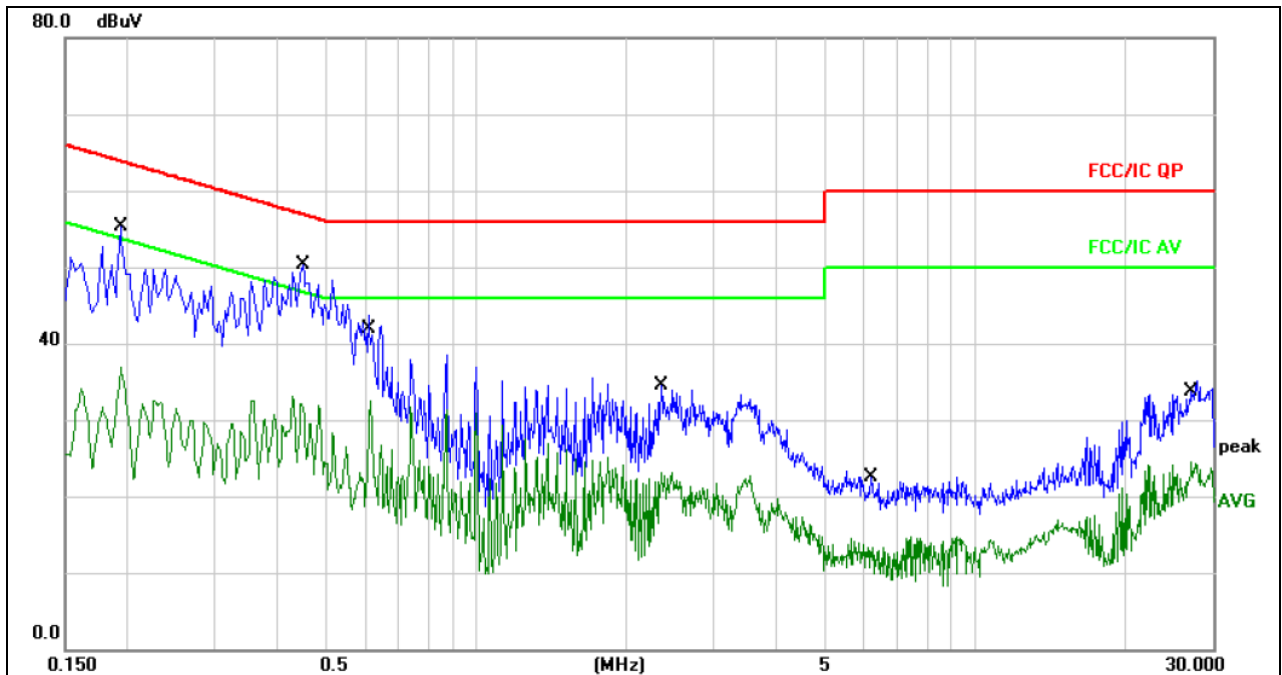

Remark:

1. All readings are Quasi-Peak and Average values.
2. Factor = Insertion Loss + Cable Loss.

No.	Mk.	Freq. MHz	Reading Level dBuV	Correct Factor dB	Measure- ment dBuV	Limit dBuV	Over dB	Detector	Comment
1		0.1940	45.17	10.06	55.23	63.86	-8.63	QP	
2		0.1940	26.85	10.06	36.91	53.86	-16.95	AVG	
3	*	0.4460	40.23	10.11	50.34	56.95	-6.61	QP	
4		0.4460	22.06	10.11	32.17	46.95	-14.78	AVG	
5		0.6180	32.19	10.13	42.32	56.00	-13.68	QP	
6		0.6180	18.49	10.13	28.62	46.00	-17.38	AVG	
7		2.3580	24.23	10.18	34.41	56.00	-21.59	QP	
8		2.3580	12.84	10.18	23.02	46.00	-22.98	AVG	
9		6.2020	12.49	10.09	22.58	60.00	-37.42	QP	
10		6.2020	3.17	10.09	13.26	50.00	-36.74	AVG	
11		27.2340	24.89	10.21	35.10	60.00	-24.90	QP	
12		27.2340	14.22	10.21	24.43	50.00	-25.57	AVG	



Temperature :	25 °C	Relative Humidity :	54%
Pressure :	1010hPa	Phase :	N
Test Voltage :	AC 120V/60Hz	Test Mode :	Mode 5

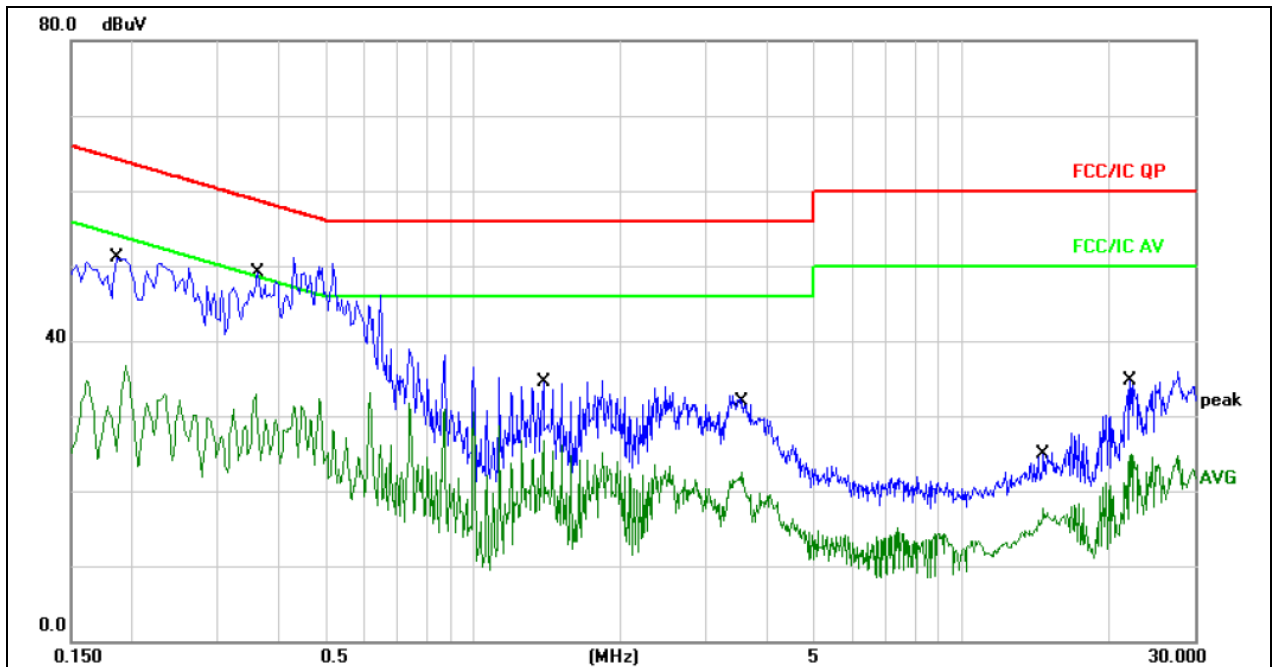

Remark:

1. All readings are Quasi-Peak and Average values.
2. Factor = Insertion Loss + Cable Loss.

No. Mk.	Freq. MHz	Reading Level dBuV	Correct Factor dB	Measurement dBuV	Limit dBuV	Over dB	Detector	Comment
1	0.1860	41.02	10.06	51.08	64.21	-13.13	QP	
2	0.1860	26.63	10.06	36.69	54.21	-17.52	AVG	
3 *	0.3580	40.96	10.10	51.06	58.77	-7.71	QP	
4	0.3580	22.83	10.10	32.93	48.77	-15.84	AVG	
5	1.3900	24.44	10.17	34.61	56.00	-21.39	QP	
6	1.3900	16.59	10.17	26.76	46.00	-19.24	AVG	
7	3.5740	15.86	10.17	26.03	56.00	-29.97	QP	
8	3.5740	10.93	10.17	21.10	46.00	-24.90	AVG	
9	14.7300	14.88	10.15	25.03	60.00	-34.97	QP	
10	14.7300	7.45	10.15	17.60	50.00	-32.40	AVG	
11	22.1780	24.45	10.18	34.63	60.00	-25.37	QP	
12	22.1780	14.77	10.18	24.95	50.00	-25.05	AVG	



3.2 RADIATED EMISSION MEASUREMENT

3.2.1 RADIATED EMISSION LIMITS (Frequency Range 9kHz-1000MHz)

20dBc in any 100 kHz bandwidth outside the operating frequency band. In case the emission fall within the restricted band specified on 15.205(a), then the 15.209(a) limit in the table below has to be followed.

Frequencies (MHz)	Field Strength (microrvolts/meter)	Measurement Distance (meters)
0.009~0.490	2400/F(KHz)	300
0.490~1.705	24000/F(KHz)	30
1.705~30.0	30	30
30~88	100	3
88~216	150	3
216~960	200	3
Above 960	500	3

LIMITS OF RADIATED EMISSION MEASUREMENT (Above 1000MHz)

FREQUENCY (MHz)	Class B (dBuV/m) (at 3M)	
	PEAK	AVERAGE
Above 1000	74	54

Notes:

- (1) The limit for radiated test was performed according to FCC PART 15C.
- (2) The tighter limit applies at the band edges.
- (3) Emission level (dBuV/m)=20log Emission level (uV/m).

Spectrum Parameter	Setting
Attenuation	Auto
Start Frequency	1000 MHz
Stop Frequency	25GHz
RB / VB (emission in restricted band)	1 MHz / 1 MHz for Peak, 1 MHz / 10Hz for Average

Receiver Parameter	Setting
Attenuation	Auto
Start ~ Stop Frequency	9kHz~150kHz / RB 200Hz for QP
Start ~ Stop Frequency	150kHz~30MHz / RB 9kHz for QP
Start ~ Stop Frequency	30MHz~1000MHz / RB 120kHz for QP

3.2.2 TEST PROCEDURE

Below 1GHz test procedure as below:

- a. The EUT was placed on the top of a rotating table 0.8 meters above the ground at a 3 meter semi-anechoic chamber. The table was rotated 360 degrees to determine the position of the highest radiation.
- b. The EUT was set 3 meters away from the interference-receiving antenna, which was mounted on the top of a variable-height antenna tower.
- c. The antenna height is varied from one meter to four meters above the ground to determine the maximum value of the field strength. Both horizontal and vertical polarizations of the antenna are set to make the measurement.
- d. For each suspected emission, the EUT was arranged to its worst case and then the antenna was tuned to heights from 1 meter to 4 meters (for the test frequency of below 30MHz, the antenna was tuned to heights 1 meter) and the rotatable table was turned from 0 degrees to 360 degrees to find the maximum reading.
- e. The test-receiver system was set to Peak Detect Function and Specified Bandwidth with Maximum Hold Mode.
- f. If the emission level of the EUT in peak mode was 10dB lower than the limit specified, then testing could be stopped and the peak values of the EUT would be reported. Otherwise the emissions that did not have 10dB margin would be re-tested one by one using peak, quasi-peak or average method as specified and then reported in a data sheet.

Above 1GHz test procedure as below:

- g. Different between above is the test site, change from Semi- Anechoic Chamber to fully Anechoic Chamber and change form table 0.8 metre to 1.5 metre(Above 18GHz the distance is 1 meter and table is 1.5 metre).
- h. Test the EUT in the lowest channel ,the middle channel ,the Highest channel

Note:

Both horizontal and vertical antenna polarities were tested and performed pretest to three orthogonal axis. The worst case emissions were reported We pretest AC 120V and AC 240V, the worst voltage was AC 120V and the data recording in the report.

3.2.3 DEVIATION FROM TEST STANDARD

No deviation

3.2.4 TEST SETUP

(A) Radiated Emission Test-Up Frequency Below 30MHz

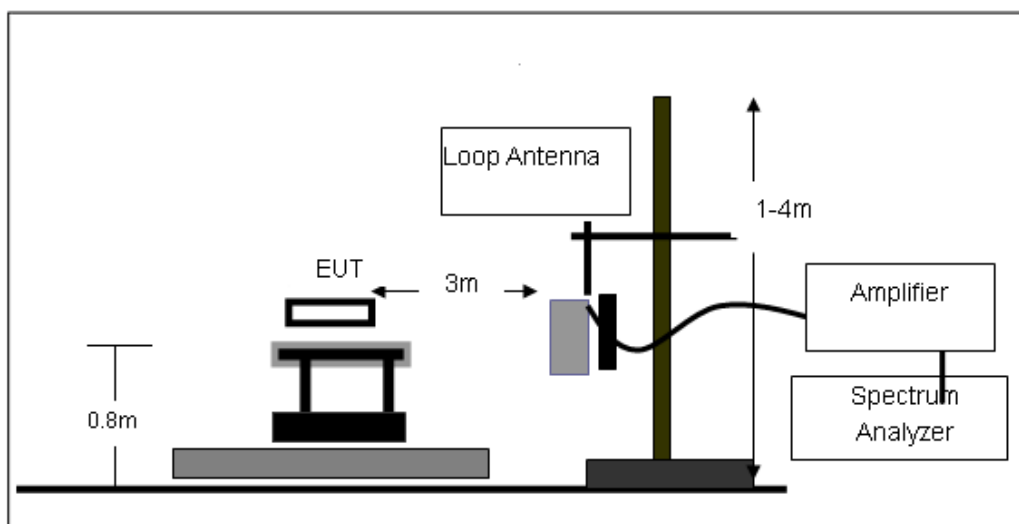

(B) Radiated Emission Test-Up Frequency 30MHz~1GHz

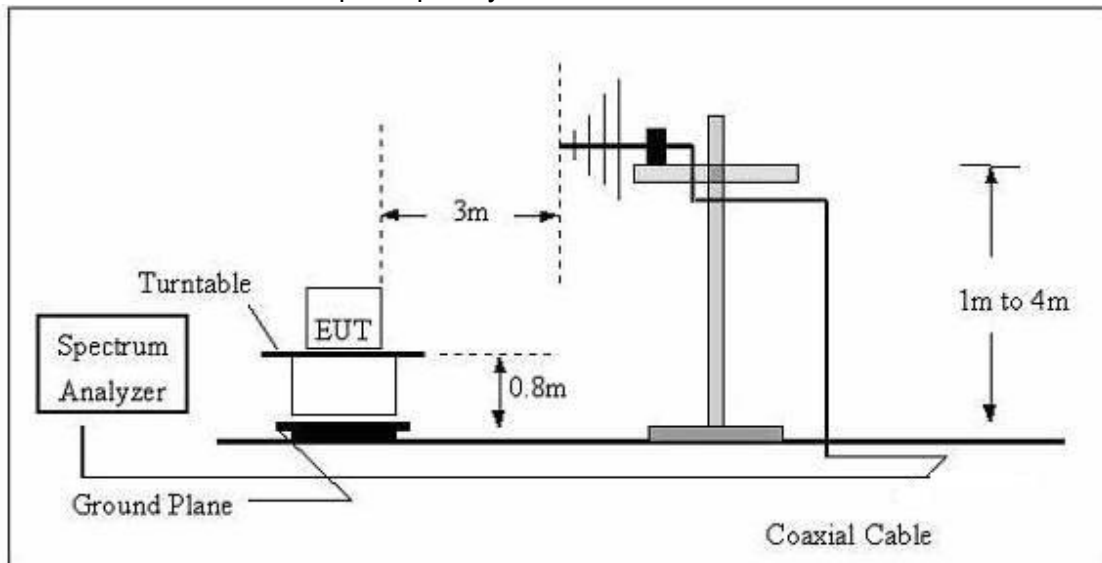

(C) Radiated Emission Test-Up Frequency Above 1GHz

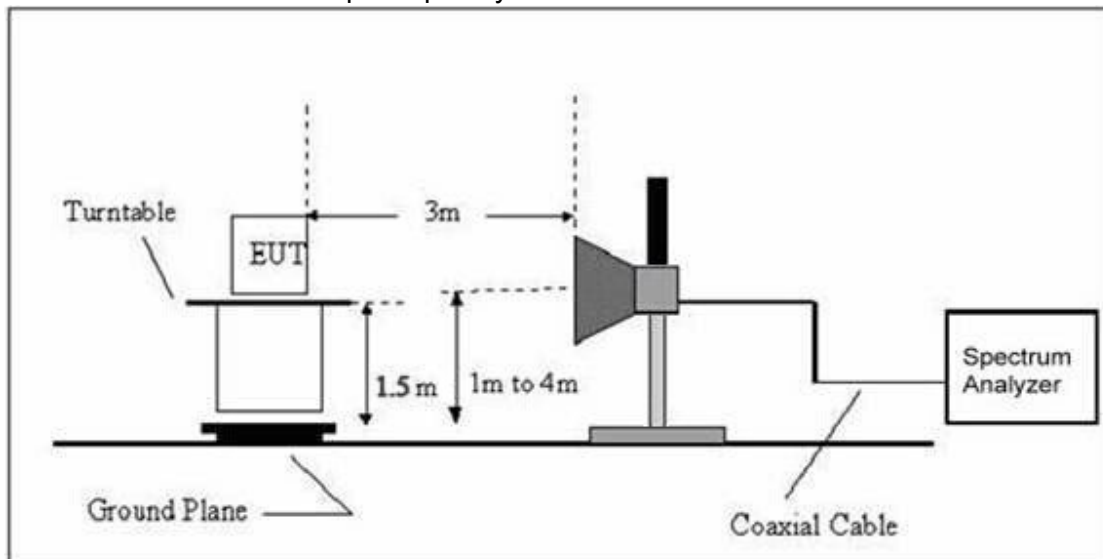

3.2.5 EUT OPERATING CONDITIONS

The EUT tested system was configured as the statements of 2.4 Unless otherwise a special operating condition is specified in the follows during the testing.

**3.2.6 TEST RESULTS (BETWEEN 9KHZ – 30 MHZ)**

Temperature:	20℃	Relative Humidity:	48%
Pressure:	1010 hPa	Test Voltage :	DC 11.4V
Test Mode :	Mode 5	Polarization :	--

Freq. (MHz)	Reading (dBuV/m)	Limit (dBuV/m)	Margin (dB)	State P/F
--	--	--	--	PASS
--	--	--	--	PASS

NOTE:

The amplitude of spurious emissions which are attenuated by more than 20dB below the permissible value has no need to be reported.

Distance extrapolation factor = $40 \log(\text{specific distance}/\text{test distance})$ (dB);

Limit line = specific limits(dBuv) + distance extrapolation factor.



3.2.7 TEST RESULTS (BETWEEN 30MHZ – 1GHZ)

Temperature :	26°C	Relative Humidity :	54%
Pressure :	1010 hPa	Polarization :	Horizontal
Test Voltage :	DC 11.4V		
Test Mode :	Mode 5		

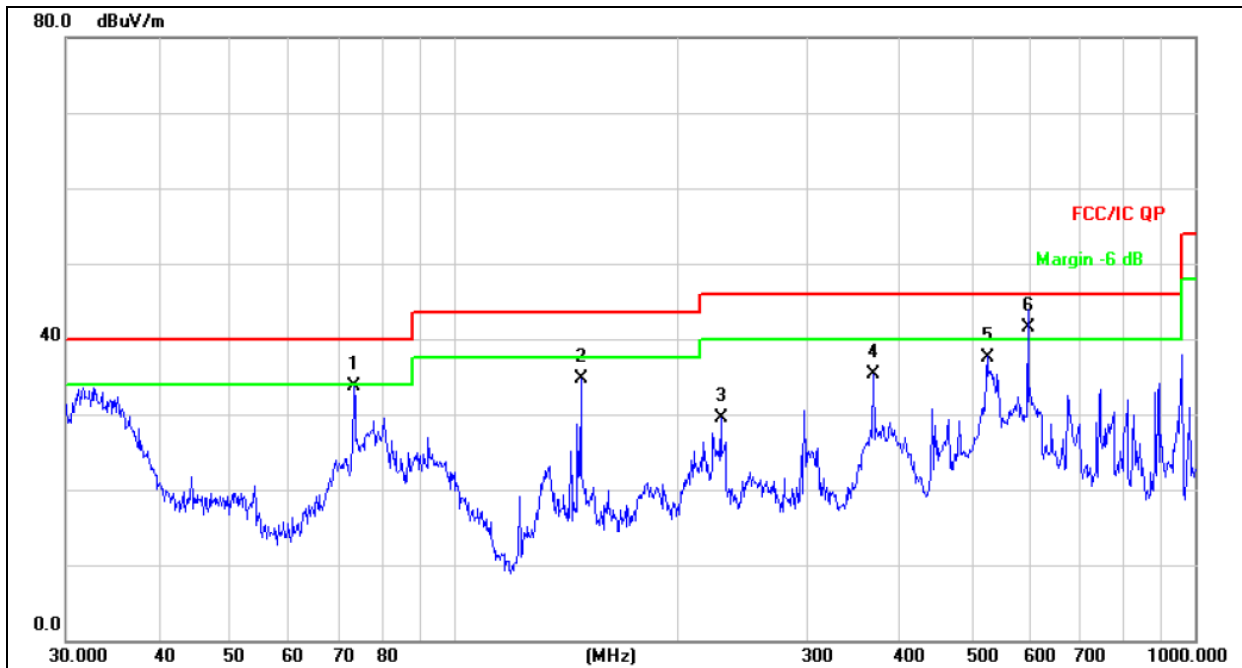

Remark:
 Factor = Antenna Factor + Cable Loss – Pre-amplifier.
 All interfaces was connected, and BT TX mode was link.

No. Mk.	Freq.	Reading Level	Correct Factor	Measurement	Limit	Over	Antenna Height	Table Degree
	MHz	dBuV	dB/m	dBuV/m	dBuV/m	dB	cm	degree
1	73.3593	49.36	-15.73	33.63	40.00	-6.37	QP	
2	148.4410	47.70	-12.93	34.77	43.50	-8.73	QP	
3	229.2931	44.55	-15.10	29.45	46.00	-16.55	QP	
4	368.1116	46.27	-10.98	35.29	46.00	-10.71	QP	
5	524.5541	45.33	-7.73	37.60	46.00	-8.40	QP	
6	* 595.1329	47.41	-5.83	41.58	46.00	-4.42	QP	



Temperature :	26°C	Relative Humidity :	54%
Pressure :	1010 hPa	Polarization :	Vertical
Test Voltage :	DC 11.4V		
Test Mode :	Mode 5		

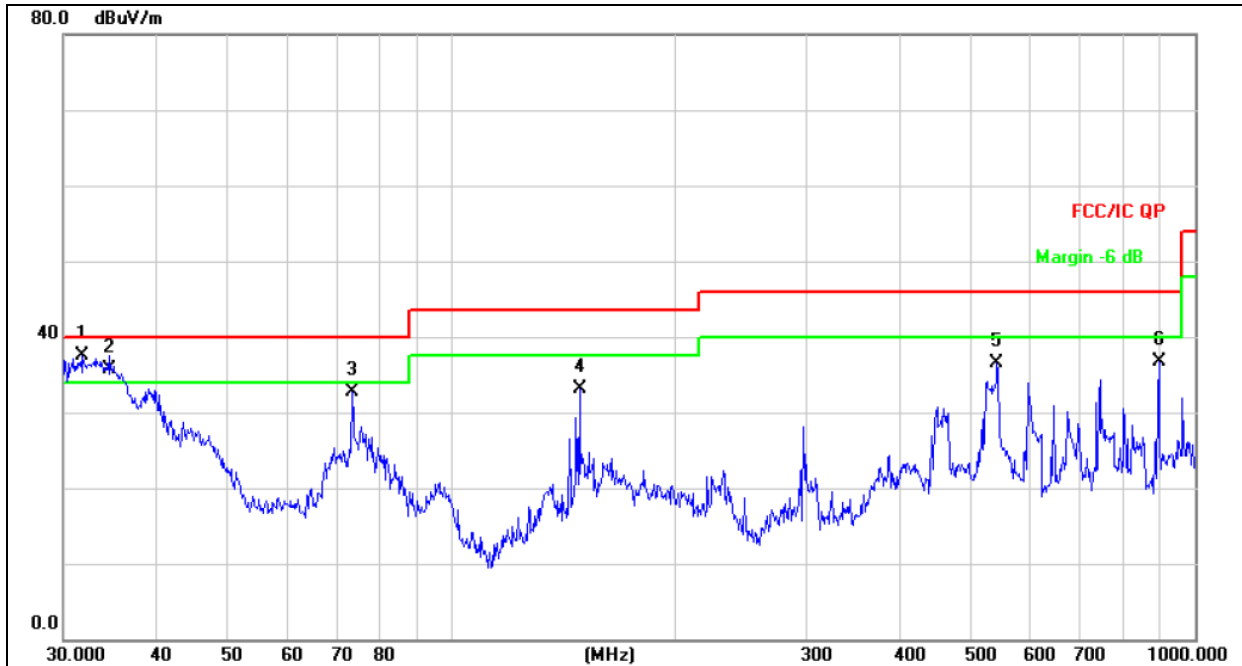

Remark:
 Factor = Antenna Factor + Cable Loss – Pre-amplifier.
 All interfaces was connected, and BT TX mode was link.

No.	Mk.	Freq.	Reading Level	Correct Factor	Measurement	Limit	Over	Antenna Height	Table Degree	
		MHz	dBuV	dB/m	dBuV/m	dBuV/m	dB	cm	degree	Comment
1	*	31.8427	45.82	-8.27	37.55	40.00	-2.45	QP		
2	!	34.5172	44.09	-8.47	35.62	40.00	-4.38	QP		
3		73.3593	48.38	-15.73	32.65	40.00	-7.35	QP		
4		148.4410	46.11	-12.93	33.18	43.50	-10.32	QP		
5		541.3724	43.90	-7.35	36.55	46.00	-9.45	QP		
6		893.8567	38.21	-1.53	36.68	46.00	-9.32	QP		



3.2.8 TEST RESULTS (1GHZ~25GHZ)

802.11b							
Polar (H/V)	Frequency	Meter Reading	Factor	Emission Level	Limits	Margin	Detector Type
	(MHz)	(dBuV)	(dB)	(dBuV/m)	(dBuV/m)	(dB)	
operation frequency:2412							
V	4824.00	41.87	19.36	61.23	74.00	-12.77	PK
V	4824.00	29.37	19.36	48.73	54.00	-5.27	AV
V	7236.00	38.12	17.17	55.29	74.00	-18.71	PK
V	7236.00	27.46	17.17	44.63	54.00	-9.37	AV
V	15450.00	31.73	20.59	52.32	74.00	-21.68	PK
H	4824.00	41.91	19.36	61.27	74.00	-12.73	AV
H	4824.00	29.18	19.36	48.54	54.00	-5.46	PK
H	7236.00	38.88	17.17	56.05	74.00	-17.95	AV
H	7236.00	29.69	17.17	46.86	54.00	-7.14	PK
H	15450.00	29.97	20.59	50.56	74.00	-23.44	AV
operation frequency:2437							
V	4874.00	42.07	19.42	61.49	74.00	-12.51	PK
V	4874.00	28.85	19.42	48.27	54.00	-5.73	AV
V	7311.00	40.11	17.19	57.30	74.00	-16.70	PK
V	7311.00	26.80	17.19	43.99	54.00	-10.01	AV
V	15450.00	31.73	20.59	52.32	74.00	-21.68	PK
H	4874.00	41.99	19.42	61.41	74.00	-12.59	AV
H	4874.00	26.64	19.42	46.06	54.00	-7.94	PK
H	7311.00	39.17	17.19	56.36	74.00	-17.64	AV
H	7311.00	26.11	17.19	43.30	54.00	-10.70	PK
H	15450.00	29.97	20.59	50.56	74.00	-23.44	AV
operation frequency:2462							
V	4924.00	41.43	19.47	60.90	74.00	-13.10	PK
V	4924.00	28.45	19.47	47.92	54.00	-6.08	AV
V	7386.00	37.93	17.22	55.15	74.00	-18.85	PK
V	7386.00	27.43	17.22	44.65	54.00	-9.35	AV
V	15450.00	31.53	20.59	52.12	74.00	-21.88	PK
H	4924.00	42.06	19.47	61.53	74.00	-12.47	AV
H	4924.00	28.18	19.47	47.65	54.00	-6.35	PK
H	7386.00	38.14	17.22	55.36	74.00	-18.64	AV
H	7386.00	28.81	17.22	46.03	54.00	-7.97	PK
H	15450.00	29.79	20.59	50.38	74.00	-23.62	AV

Remark:

1. Emission Level = Meter Reading + Factor, Margin= Emission Level - Limit
2. If peak below the average limit, the average emission was no test.
3. The amplitude of spurious emissions which are attenuated by more than 20dB below the permissible value has no need to be reported.



802.11g

Polar (H/V)	Frequency	Meter Reading	Factor	Emission Level	Limits	Margin	Detector Type
	(MHz)	(dBuV)	(dB)	(dBuV/m)	(dBuV/m)	(dB)	
operation frequency:2412							
V	4824.00	39.84	19.36	59.20	74.00	-14.80	PK
V	4824.00	29.33	19.36	48.69	54.00	-5.31	AV
V	7236.00	40.05	17.17	57.22	74.00	-16.78	PK
V	7236.00	29.40	17.17	46.57	54.00	-7.43	AV
V	15450.00	31.69	20.59	52.28	74.00	-21.72	PK
H	4824.00	39.88	19.36	59.24	74.00	-14.76	PK
H	4824.00	29.14	19.36	48.50	54.00	-5.50	AV
H	7236.00	39.82	17.17	56.99	74.00	-17.01	PK
H	7236.00	29.65	17.17	46.82	54.00	-7.18	AV
H	15450.00	29.93	20.59	50.52	74.00	-23.48	PK
operation frequency:2437							
V	4874.00	42.15	19.42	61.57	74.00	-12.43	PK
V	4874.00	28.91	19.42	48.33	54.00	-5.67	AV
V	7311.00	40.19	17.19	57.38	74.00	-16.62	PK
V	7311.00	26.85	17.19	44.04	54.00	-9.96	AV
V	15450.00	31.80	20.59	52.39	74.00	-21.61	PK
H	4874.00	42.07	19.42	61.49	74.00	-12.51	PK
H	4874.00	26.70	19.42	46.12	54.00	-7.88	AV
H	7311.00	39.25	17.19	56.44	74.00	-17.56	PK
H	7311.00	26.17	17.19	43.36	54.00	-10.64	AV
H	15450.00	30.03	20.59	50.62	74.00	-23.38	PK
operation frequency:2462							
V	4924.00	41.38	19.47	60.85	74.00	-13.15	PK
V	4924.00	28.42	19.47	47.89	54.00	-6.11	AV
V	7386.00	37.88	17.22	55.10	74.00	-18.90	PK
V	7386.00	27.39	17.22	44.61	54.00	-9.39	AV
V	15450.00	31.49	20.59	52.08	74.00	-21.92	PK
H	4924.00	42.00	19.47	61.47	74.00	-12.53	PK
H	4924.00	28.14	19.47	47.61	54.00	-6.39	AV
H	7386.00	38.09	17.22	55.31	74.00	-18.69	PK
H	7386.00	28.77	17.22	45.99	54.00	-8.01	AV
H	15450.00	29.75	20.59	50.34	74.00	-23.66	PK
Remark: 1. Emission Level = Meter Reading + Factor, Margin= Emission Level - Limit 2. If peak below the average limit, the average emission was no test. 3. The amplitude of spurious emissions which are attenuated by more than 20dB below the permissible value has no need to be reported.							



802.11n(20MHz)

Polar (H/V)	Frequency	Meter Reading	Factor	Emission Level	Limits	Margin	Detector Type
	(MHz)	(dBuV)	(dB)	(dBuV/m)	(dBuV/m)	(dB)	
operation frequency:2412							
V	4824.00	39.97	19.36	59.33	74.00	-14.67	PK
V	4824.00	29.43	19.36	48.79	54.00	-5.21	AV
V	7236.00	40.18	17.17	57.35	74.00	-16.65	PK
V	7236.00	29.50	17.17	46.67	54.00	-7.33	AV
V	15450.00	31.79	20.59	52.38	74.00	-21.62	PK
H	4824.00	40.01	19.36	59.37	74.00	-14.63	PK
H	4824.00	29.24	19.36	48.60	54.00	-5.40	AV
H	7236.00	39.95	17.17	57.12	74.00	-16.88	PK
H	7236.00	29.75	17.17	46.92	54.00	-7.08	AV
H	15450.00	30.03	20.59	50.62	74.00	-23.38	PK

operation frequency:2437							
V	4874.00	42.15	19.42	61.57	74.00	-12.43	PK
V	4874.00	28.91	19.42	48.33	54.00	-5.67	AV
V	7311.00	40.19	17.19	57.38	74.00	-16.62	PK
V	7311.00	26.85	17.19	44.04	54.00	-9.96	AV
V	15450.00	31.79	20.59	52.38	74.00	-21.62	PK
H	4874.00	42.07	19.42	61.49	74.00	-12.51	PK
H	4874.00	26.69	19.42	46.11	54.00	-7.89	AV
H	7311.00	39.25	17.19	56.44	74.00	-17.56	PK
H	7311.00	26.16	17.19	43.35	54.00	-10.65	AV
H	15450.00	30.03	20.59	50.62	74.00	-23.38	PK

operation frequency:2462							
V	4924.00	41.51	19.47	60.98	74.00	-13.02	PK
V	4924.00	28.49	19.47	47.96	54.00	-6.04	AV
V	7386.00	38.00	17.22	55.22	74.00	-18.78	PK
V	7386.00	27.48	17.22	44.70	54.00	-9.30	AV
V	15450.00	31.59	20.59	52.18	74.00	-21.82	PK
H	4924.00	42.14	19.47	61.61	74.00	-12.39	PK
H	4924.00	28.23	19.47	47.70	54.00	-6.30	AV
H	7386.00	38.21	17.22	55.43	74.00	-18.57	PK
H	7386.00	28.87	17.22	46.09	54.00	-7.91	AV
H	15450.00	29.85	20.59	50.44	74.00	-23.56	PK

Remark:
 1. Emission Level = Meter Reading + Factor, Margin= Emission Level - Limit
 2. If peak below the average limit, the average emission was no test.
 3. The amplitude of spurious emissions which are attenuated by more than 20dB below the permissible value has no need to be reported.



802.11n(40MHz)

Polar (H/V)	Frequency	Meter Reading	Factor	Emission Level	Limits	Margin	Detector Type
	(MHz)	(dBuV)	(dB)	(dBuV/m)	(dBuV/m)	(dB)	
operation frequency:2422							
V	4844.000	39.49	19.37	58.86	74.00	-15.14	PK
V	4844.000	29.07	19.37	48.44	54.00	-5.56	AV
V	7266.000	39.69	17.18	56.87	74.00	-17.13	PK
V	7266.000	29.14	17.18	46.32	54.00	-7.68	AV
V	15450.00	31.41	20.59	52.00	74.00	-22.00	PK
H	4844.000	39.53	19.37	58.90	74.00	-15.10	PK
H	4844.000	28.89	19.37	48.26	54.00	-5.74	AV
H	7266.000	39.47	17.18	56.65	74.00	-17.35	PK
H	7266.000	29.40	17.18	46.58	54.00	-7.42	AV
H	15450.00	29.66	20.59	50.25	74.00	-23.75	PK

operation frequency:2437							
V	4874.00	41.56	19.42	60.98	74.00	-13.02	PK
V	4874.00	28.50	19.42	47.92	54.00	-6.08	AV
V	7311.00	39.62	17.19	56.81	74.00	-17.19	PK
V	7311.00	26.47	17.19	43.66	54.00	-10.34	AV
V	15450.00	31.35	20.59	51.94	74.00	-22.06	PK
H	4874.00	41.48	19.42	60.90	74.00	-13.10	PK
H	4874.00	26.32	19.42	45.74	54.00	-8.26	AV
H	7311.00	38.69	17.19	55.88	74.00	-18.12	PK
H	7311.00	25.80	17.19	42.99	54.00	-11.01	AV
H	15450.00	29.60	20.59	50.19	74.00	-23.81	PK

operation frequency:2452							
V	4904.00	41.01	19.44	60.45	74.00	-13.55	PK
V	4904.00	28.16	19.44	47.60	54.00	-6.40	AV
V	7356.00	37.54	17.21	54.75	74.00	-19.25	PK
V	7356.00	27.16	17.21	44.37	54.00	-9.63	AV
V	15450.00	31.21	20.59	51.80	74.00	-22.20	PK
H	4904.00	41.63	19.44	61.07	74.00	-12.93	PK
H	4904.00	27.88	19.44	47.32	54.00	-6.68	AV
H	7356.00	37.75	17.21	54.96	74.00	-19.04	PK
H	7356.00	28.52	17.21	45.73	54.00	-8.27	AV
H	15450.00	29.50	20.59	50.09	74.00	-23.91	PK

Remark:

1. Emission Level = Meter Reading + Factor, Margin= Emission Level - Limit
2. If peak below the average limit, the average emission was no test.
3. The amplitude of spurious emissions which are attenuated by more than 20dB below the permissible value has no need to be reported.



For Conducted
802.11b
2412MHz

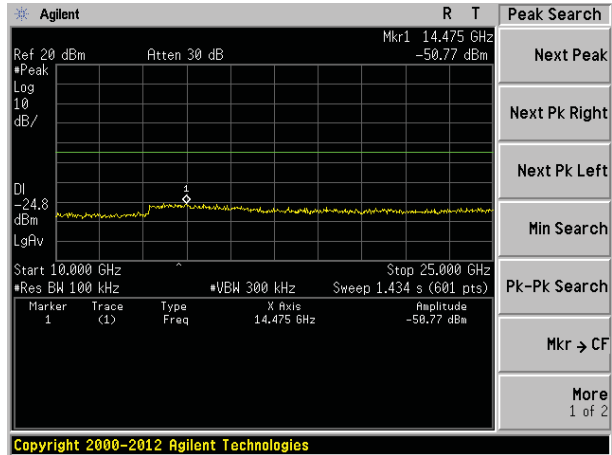
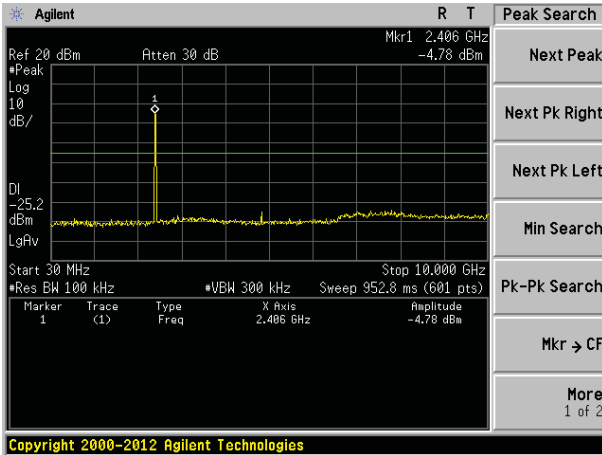

2437MHz

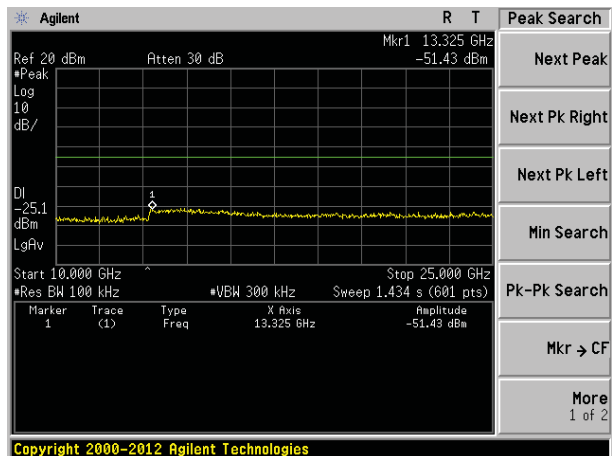
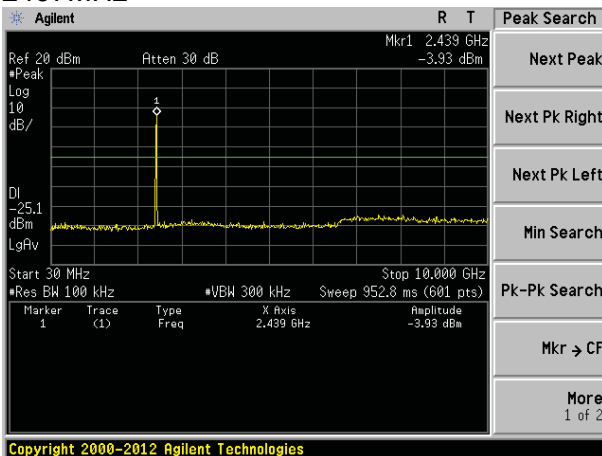

2462MHz

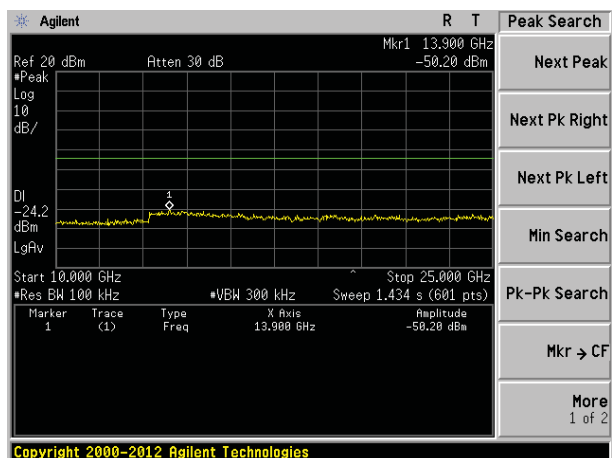
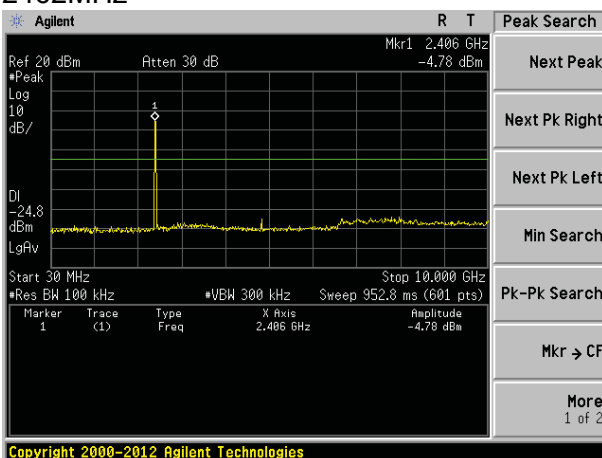



802.11g
2412MHz

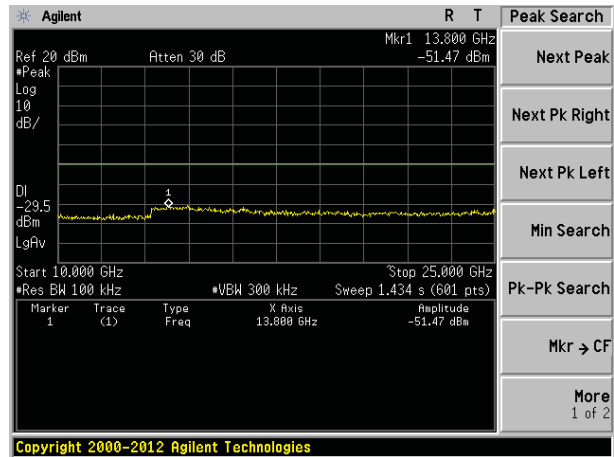
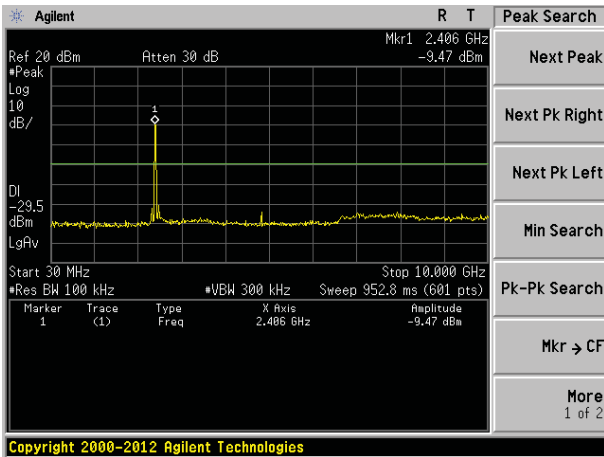

2437MHz

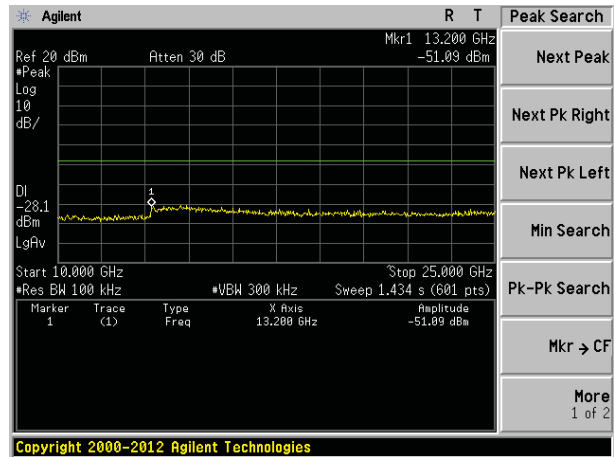
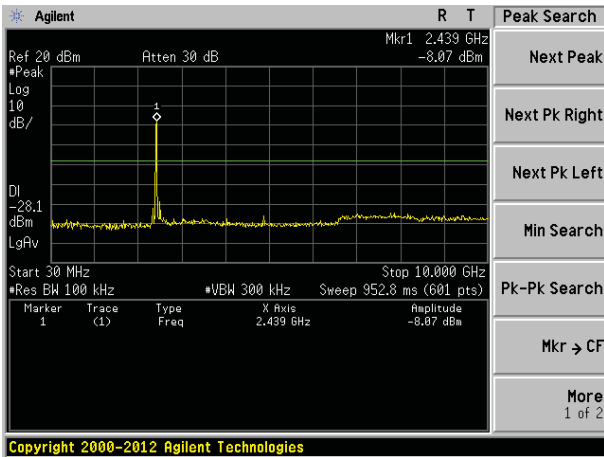

2462MHz

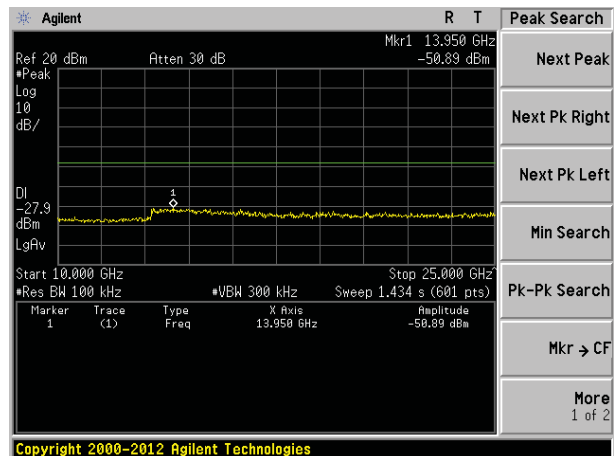
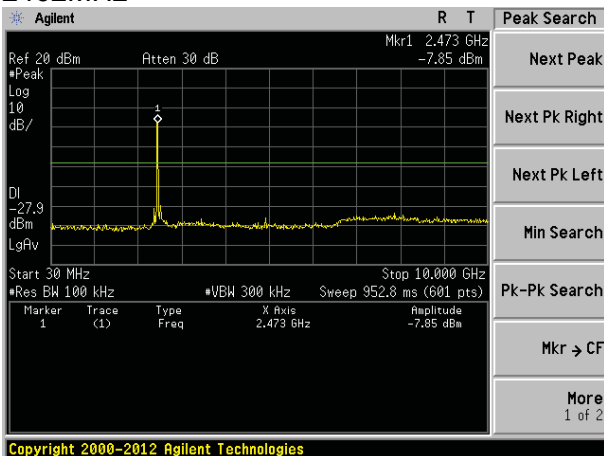



802.11n 20MHz 2412MHz

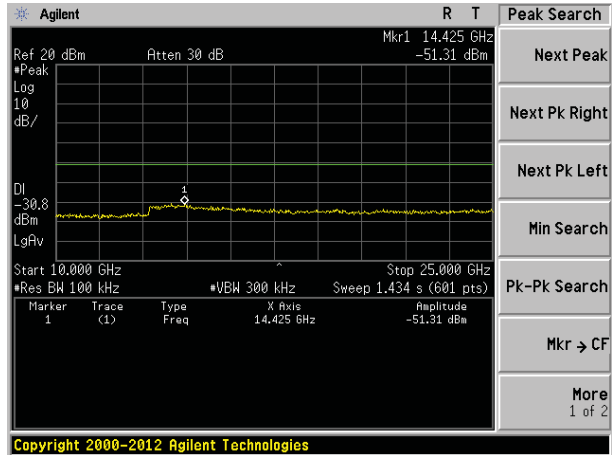
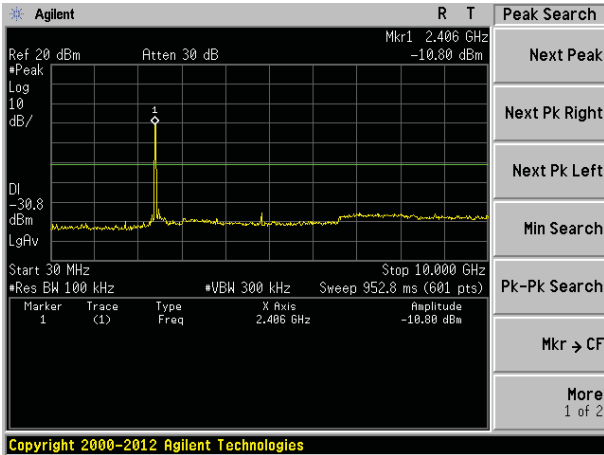

2437MHz

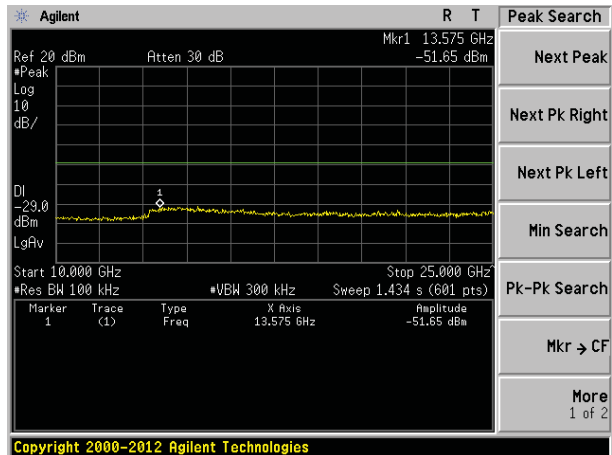
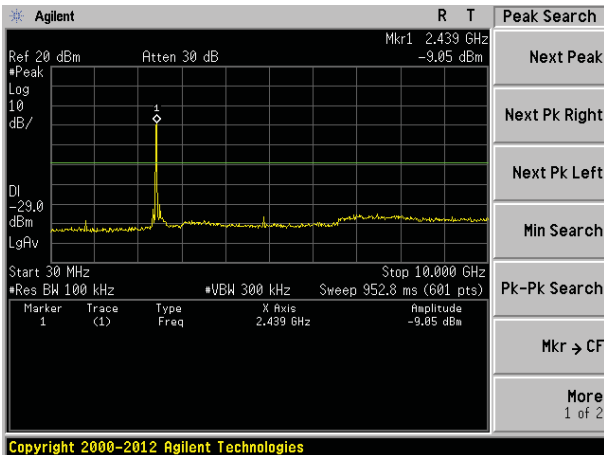

2462MHz

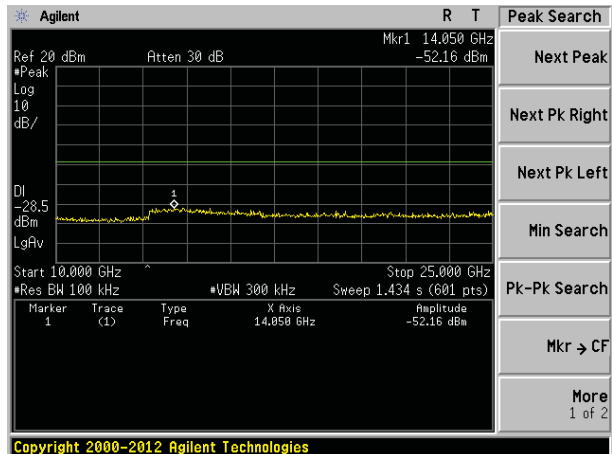
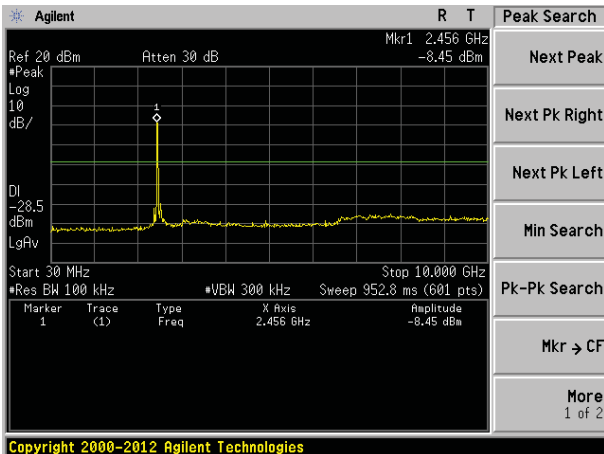



802.11n 40MHz 2422MHz

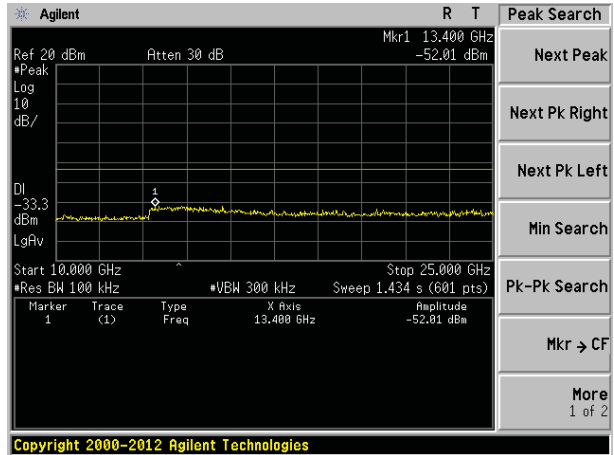
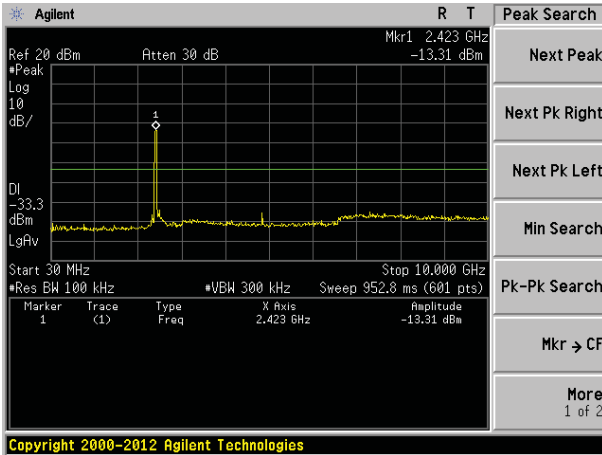

2437MHz

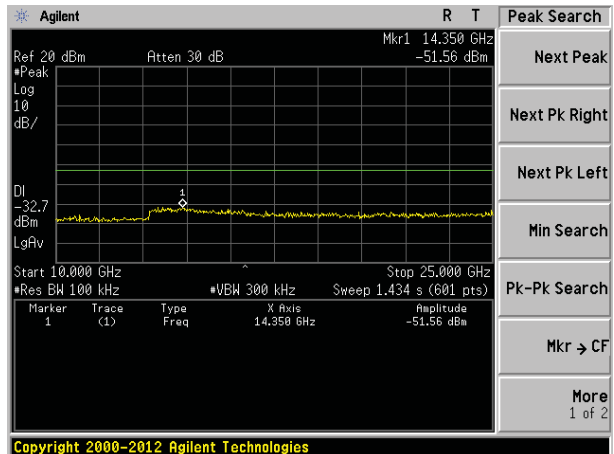
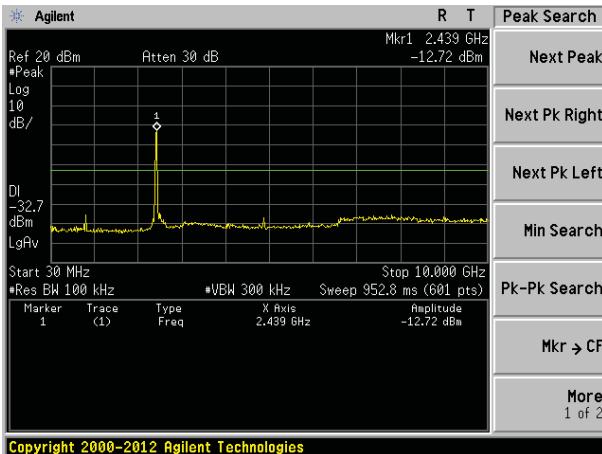

2452MHz

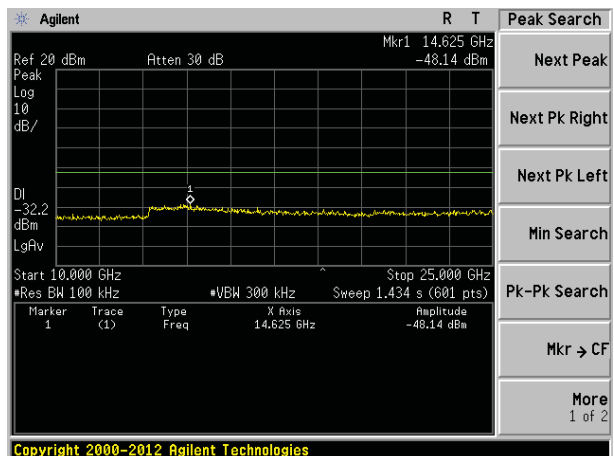
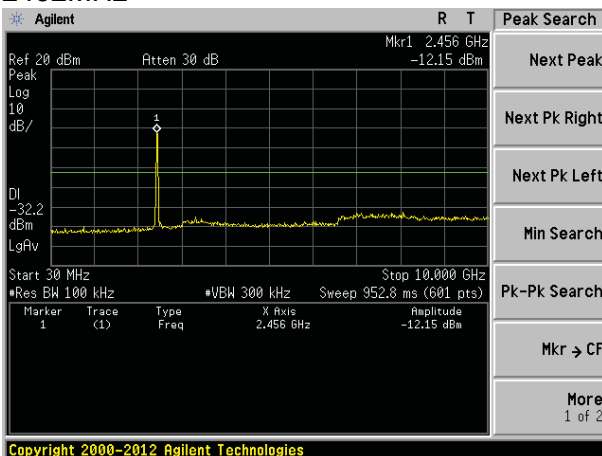



3.3 RADIATED BAND EMISSION MEASUREMENT

3.3.1 TEST REQUIREMENT:

FCC Part15 C Section 15.209 and 15.205

LIMITS OF RADIATED EMISSION MEASUREMENT (Above 1000MHz)

FREQUENCY (MHz)	Class B (dBuV/m) (at 3M)	
	PEAK	AVERAGE
Above 1000	74	54

Notes:

- (1) The limit for radiated test was performed according to FCC PART 15C.
- (2) The tighter limit applies at the band edges.
- (3) Emission level (dBuV/m)=20log Emission level (uV/m).

Spectrum Parameter	Setting
Attenuation	Auto
Start Frequency	2300MHz
Stop Frequency	2520
RB / VB (emission in restricted band)	1 MHz / 1 MHz for Peak, 1 MHz / 10Hz for Average

3.3.2 TEST PROCEDURE

Above 1GHz test procedure as below:

- a. 1. The EUT was placed on the top of a rotating table 1.5 meters above the ground at a 3 meter camber. The table was rotated 360 degrees to determine the position of the highest radiation.
- b. The EUT was set 3 meters away from the interference-receiving antenna, which was mounted on the top of a variable-height antenna tower.
- c. The antenna height is varied from one meter to four meters above the ground to determine the maximum value of the field strength. Both horizontal and vertical polarizations of the antenna are set to make the measurement.
- d. For each suspected emission, the EUT was arranged to its worst case and then the antenna was tuned to heights from 1 meter to 4 meters and the rota table was turned from 0 degrees to 360 degrees to find the maximum reading.
- e. The test-receiver system was set to Peak Detect Function and Specified Bandwidth with Maximum Hold Mode.
- f. If the emission level of the EUT in peak mode was 10dB lower than the limit specified, then testing could be stopped and the peak values of the EUT would be reported. Otherwise the emissions that did not have 10dB margin would be re-tested one by one using peak, quasi-peak or average method as specified and then reported in a data sheet.
- g. Test the EUT in the lowest channel,the Highest channel

Note:

Both horizontal and vertical antenna polarities were tested and performed pretest to three orthogonal axis. The worst case emissions were reported

3.3.3 DEVIATION FROM TEST STANDARD

No deviation

3.3.4 TEST SETUP

Radiated Emission Test-Up Frequency Above 1GHz

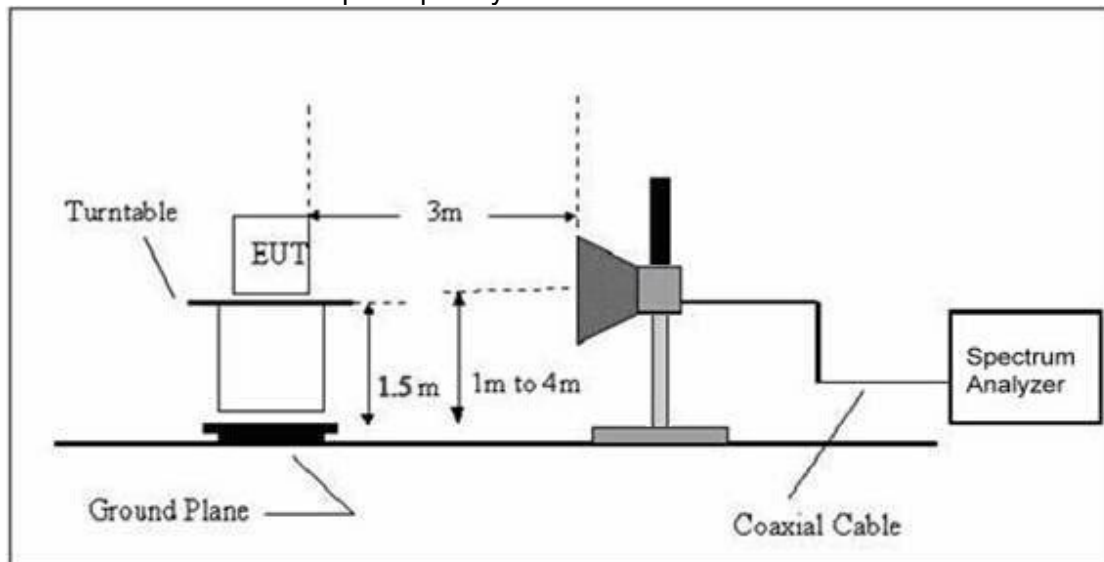

3.3.5 EUT OPERATING CONDITIONS

The EUT tested system was configured as the statements of 2.3 Unless otherwise a special operating condition is specified in the follows during the testing.



3.3.6 TEST RESULT

802.11b

Polar (H/V)	Frequency	Meter Reading	Factor	Emission Level	Limits	Margin	Detector Type
	(MHz)	(dBuV)	(dB)	(dBuV/m)	(dBuV/m)	(dB)	
operation frequency:2412							
V	2390.00	37.77	13.83	51.60	74.00	-22.40	PK
V	2390.00	26.24	13.83	40.07	54.00	-13.93	AV
V	2400.00	37.98	13.85	51.83	74.00	-22.17	PK
V	2400.00	25.81	13.85	39.66	54.00	-14.34	AV
H	2390.00	38.07	13.83	51.90	74.00	-22.10	PK
H	2390.00	26.27	13.83	40.10	54.00	-13.90	AV
H	2400.00	37.93	13.85	51.78	74.00	-22.22	PK
H	2400.00	26.22	13.85	40.07	54.00	-13.93	AV

Polar (H/V)	Frequency	Meter Reading	Factor	Emission Level	Limits	Margin	Detector Type
	(MHz)	(dBuV)	(dB)	(dBuV/m)	(dBuV/m)	(dB)	
operation frequency:2462							
V	2483.50	37.98	14.02	52.00	74.00	-22.00	PK
V	2483.50	26.48	14.02	40.50	54.00	-13.50	AV
V	2500.00	37.92	14.06	51.98	74.00	-22.02	PK
V	2500.00	25.92	14.06	39.98	54.00	-14.02	AV
H	2483.50	38.11	14.02	52.13	74.00	-21.87	PK
H	2483.50	26.52	14.02	40.54	54.00	-13.46	AV
H	2500.00	37.72	14.06	51.78	74.00	-22.22	PK
H	2500.00	26.78	14.06	40.84	54.00	-13.16	AV

Remark:

1. Emission Level = Meter Reading + Factor, Margin= Emission Level - Limit
2. If peak below the average limit, the average emission was no test.
3. The amplitude of spurious emissions which are attenuated by more than 20dB below the permissible value has no need to be reported.



802.11g

Polar (H/V)	Frequency	Meter Reading	Factor	Emission Level	Limits	Margin	Detector Type
	(MHz)	(dBuV)	(dB)	(dBuV/m)	(dBuV/m)	(dB)	
operation frequency:2412							
V	2390.00	37.46	13.83	51.29	74.00	-22.71	PK
V	2390.00	26.03	13.83	39.86	54.00	-14.14	AV
V	2400.00	37.67	13.85	51.52	74.00	-22.48	PK
V	2400.00	25.60	13.85	39.45	54.00	-14.55	AV
H	2390.00	37.76	13.83	51.59	74.00	-22.41	PK
H	2390.00	26.06	13.83	39.89	54.00	-14.11	AV
H	2400.00	37.62	13.85	51.47	74.00	-22.53	PK
H	2400.00	26.00	13.85	39.85	54.00	-14.15	AV

Polar (H/V)	Frequency	Meter Reading	Factor	Emission Level	Limits	Margin	Detector Type
	(MHz)	(dBuV)	(dB)	(dBuV/m)	(dBuV/m)	(dB)	
operation frequency:2462							
V	2483.50	37.67	14.02	51.69	74.00	-22.31	PK
V	2483.50	26.27	14.02	40.29	54.00	-13.71	AV
V	2500.00	37.61	14.06	51.67	74.00	-22.33	PK
V	2500.00	25.71	14.06	39.77	54.00	-14.23	AV
H	2483.50	37.80	14.02	51.82	74.00	-22.18	PK
H	2483.50	26.31	14.02	40.33	54.00	-13.67	AV
H	2500.00	37.41	14.06	51.47	74.00	-22.53	PK
H	2500.00	26.56	14.06	40.62	54.00	-13.38	AV

Remark:

1. Emission Level = Meter Reading + Factor, Margin= Emission Level - Limit
2. If peak below the average limit, the average emission was no test.
3. The amplitude of spurious emissions which are attenuated by more than 20dB below the permissible value has no need to be reported.



802.11n(20MHz)

Polar (H/V)	Frequency	Meter Reading	Factor	Emission Level	Limits	Margin	Detector Type
	(MHz)	(dBuV)	(dB)	(dBuV/m)	(dBuV/m)	(dB)	
operation frequency:2412							
V	2390.00	37.57	13.83	51.40	74.00	-22.60	PK
V	2390.00	26.11	13.83	39.94	54.00	-14.06	AV
V	2400.00	37.78	13.85	51.63	74.00	-22.37	PK
V	2400.00	25.67	13.85	39.52	54.00	-14.48	AV
H	2390.00	37.87	13.83	51.70	74.00	-22.30	PK
H	2390.00	26.14	13.83	39.97	54.00	-14.03	AV
H	2400.00	37.73	13.85	51.58	74.00	-22.42	PK
H	2400.00	26.08	13.85	39.93	54.00	-14.07	AV

Polar (H/V)	Frequency	Meter Reading	Factor	Emission Level	Limits	Margin	Detector Type
	(MHz)	(dBuV)	(dB)	(dBuV/m)	(dBuV/m)	(dB)	
operation frequency:2462							
V	2483.50	37.78	14.02	51.80	74.00	-22.20	PK
V	2483.50	26.34	14.02	40.36	54.00	-13.64	AV
V	2500.00	37.72	14.06	51.78	74.00	-22.22	PK
V	2500.00	25.78	14.06	39.84	54.00	-14.16	AV
H	2483.50	37.91	14.02	51.93	74.00	-22.07	PK
H	2483.50	26.38	14.02	40.40	54.00	-13.60	AV
H	2500.00	37.52	14.06	51.58	74.00	-22.42	PK
H	2500.00	26.63	14.06	40.69	54.00	-13.31	AV

Remark:

1. Emission Level = Meter Reading + Factor, Margin= Emission Level - Limit
2. If peak below the average limit, the average emission was no test.
3. The amplitude of spurious emissions which are attenuated by more than 20dB below the permissible value has no need to be reported.



802.11n(40MHz)

Polar (H/V)	Frequency	Meter Reading	Factor	Emission Level	Limits	Margin	Detector Type
	(MHz)	(dBuV)	(dB)	(dBuV/m)	(dBuV/m)	(dB)	
operation frequency:2422							
V	2390.00	37.89	13.83	51.72	74.00	-22.28	PK
V	2390.00	26.32	13.83	40.15	54.00	-13.85	AV
V	2400.00	38.10	13.85	51.95	74.00	-22.05	PK
V	2400.00	25.89	13.85	39.74	54.00	-14.26	AV
H	2390.00	38.19	13.83	52.02	74.00	-21.98	PK
H	2390.00	26.34	13.83	40.17	54.00	-13.83	AV
H	2400.00	38.05	13.85	51.90	74.00	-22.10	PK
H	2400.00	26.29	13.85	40.14	54.00	-13.86	AV

Polar (H/V)	Frequency	Meter Reading	Factor	Emission Level	Limits	Margin	Detector Type
	(MHz)	(dBuV)	(dB)	(dBuV/m)	(dBuV/m)	(dB)	
operation frequency:2452							
V	2483.50	38.10	14.02	52.12	74.00	-21.88	PK
V	2483.50	26.56	14.02	40.58	54.00	-13.42	AV
V	2500.00	38.04	14.06	52.10	74.00	-21.90	PK
V	2500.00	26.00	14.06	40.06	54.00	-13.94	AV
H	2483.50	38.23	14.02	52.25	74.00	-21.75	PK
H	2483.50	26.60	14.02	40.62	54.00	-13.38	AV
H	2500.00	37.84	14.06	51.90	74.00	-22.10	PK
H	2500.00	26.86	14.06	40.92	54.00	-13.08	AV

Remark:

1. Emission Level = Meter Reading + Factor, Margin= Emission Level - Limit
2. If peak below the average limit, the average emission was no test.
3. The amplitude of spurious emissions which are attenuated by more than 20dB below the permissible value has no need to be reported.



4. POWER SPECTRAL DENSITY TEST

4.1 APPLIED PROCEDURES / LIMIT

FCC Part15 (15.247) , Subpart C				
Section	Test Item	Limit	Frequency Range (MHz)	Result
15.247	Power Spectral Density	8 dBm (in any 3KHz)	2400-2483.5	PASS

4.1.1 TEST PROCEDURE

1. Set analyzer center frequency to DTS channel center frequency.
2. Set the span to 1.5 times the DTS bandwidth.
3. Set the RBW to: $3\text{ kHz} \leq \text{RBW} \leq 100\text{ kHz}$.
4. Set the VBW $\geq 3 \times \text{RBW}$.
5. Detector = peak.
6. Sweep time = auto couple.
7. Trace mode = max hold.
8. Allow trace to fully stabilize.
9. Use the peak marker function to determine the maximum amplitude level within the RBW.
10. If measured value exceeds limit, reduce RBW (no less than 3 kHz) and repeat.

4.1.2 DEVIATION FROM STANDARD

No deviation.

4.1.3 TEST SETUP

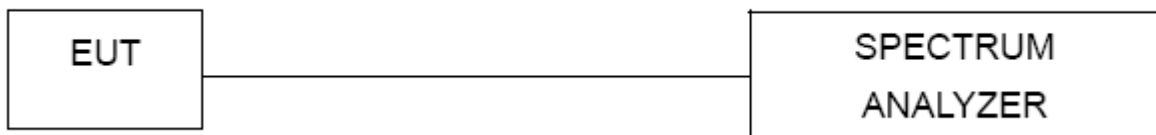

4.1.4 EUT OPERATION CONDITIONS

The EUT tested system was configured as the statements of 2.1 Unless otherwise a special operating condition is specified in the follows during the testing.



4.1.5 TEST RESULTS

Temperature :	25°C	Relative Humidity :	60%
Pressure :	1015 hPa	Test Voltage :	DC 11.4V
Test Mode :	TX b Mode		

Frequency	Power Spectral Density(dBm)	Limit (dBm)	Result
2412 MHz	-4.45	8	PASS
2437 MHz	-3.90	8	PASS
2462 MHz	-3.27	8	PASS

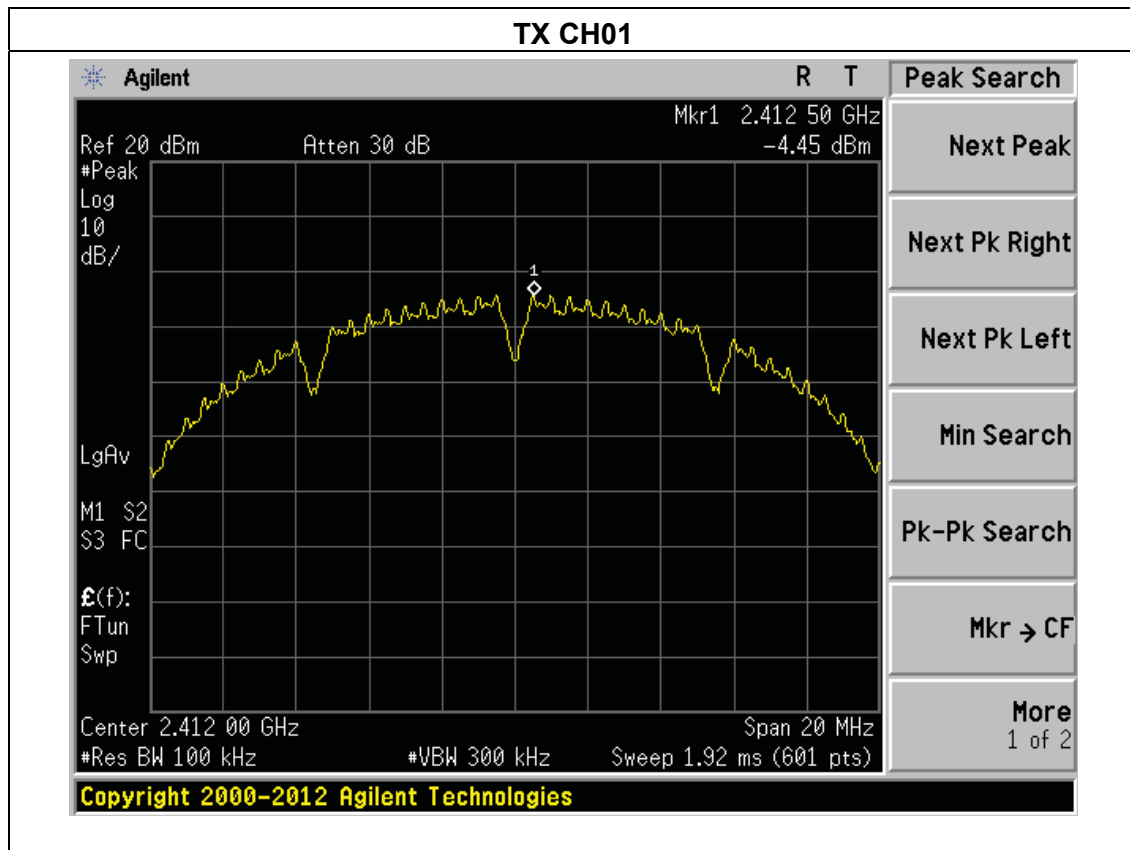

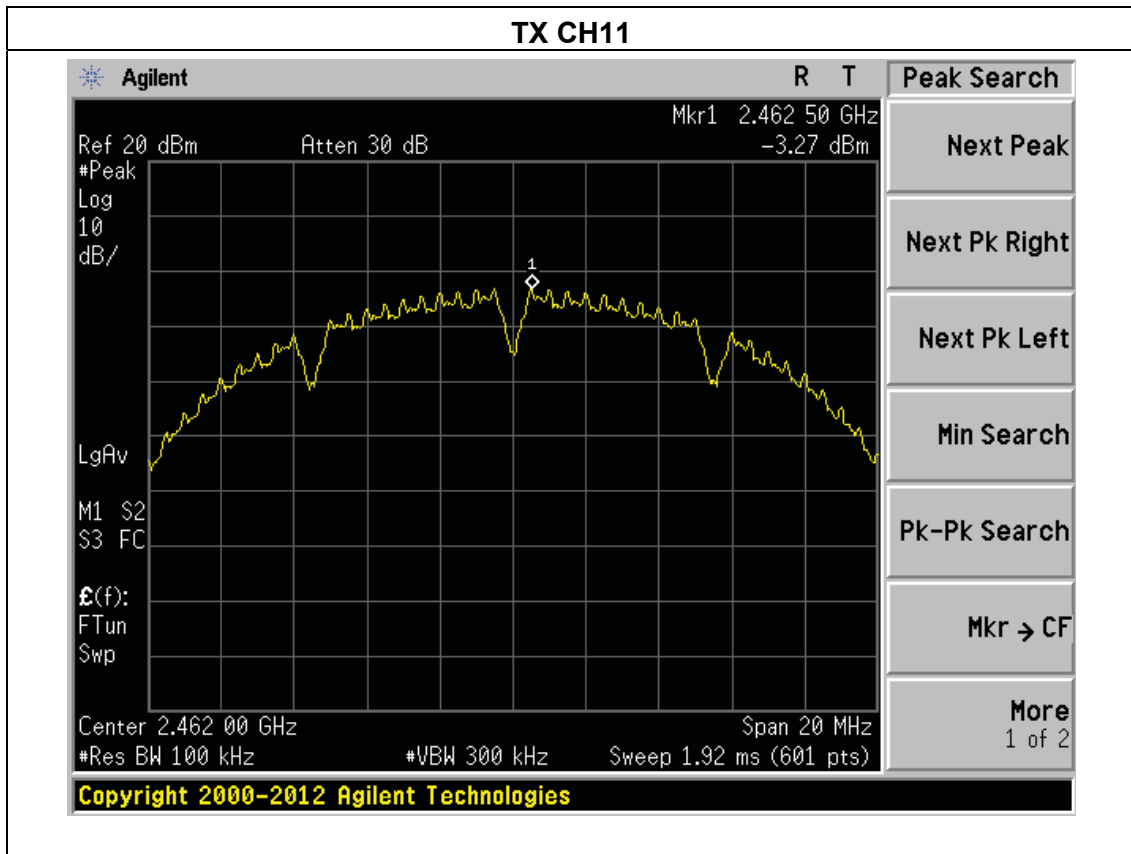
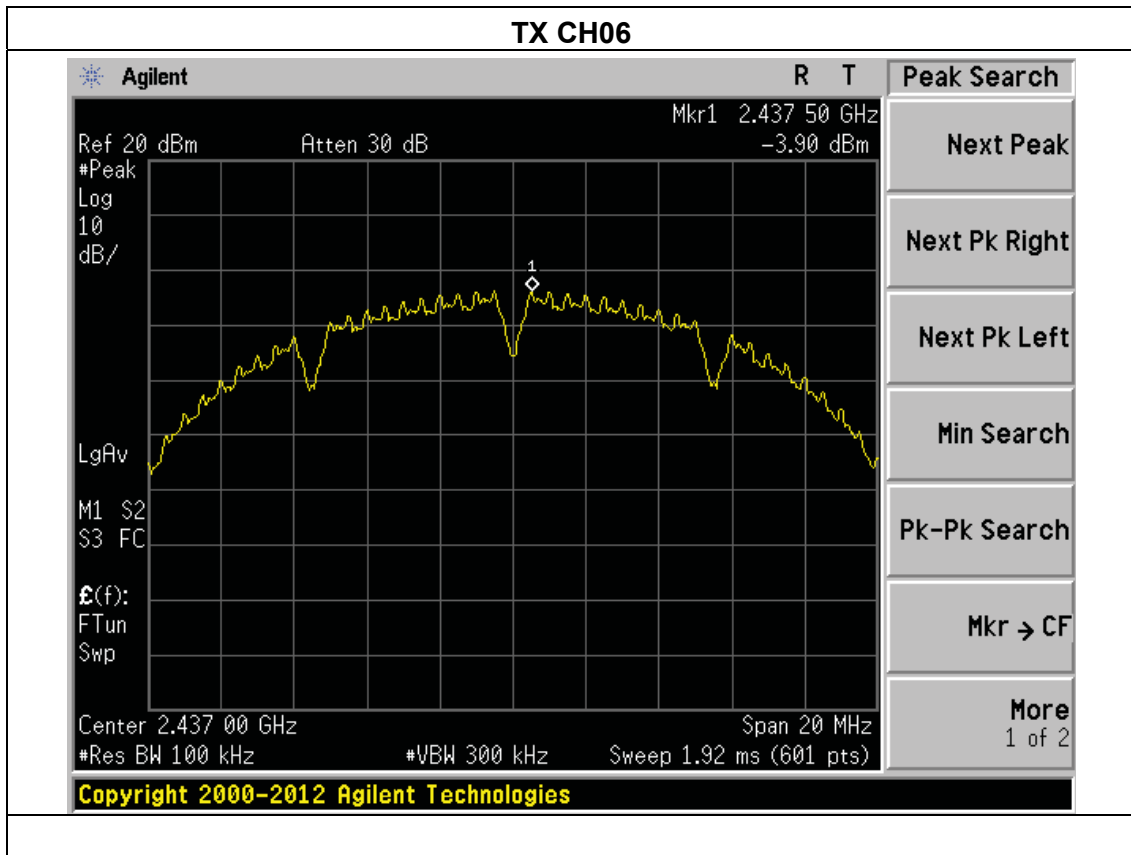



Temperature :	25°C	Relative Humidity :	60%
Pressure :	1015 hPa	Test Voltage :	DC 11.4V
Test Mode :	TX g Mode		

Frequency	Power Spectral Density(dBm)	Limit (dBm)	Result
2412 MHz	-8.21	8	PASS
2437 MHz	-7.53	8	PASS
2462 MHz	-6.89	8	PASS

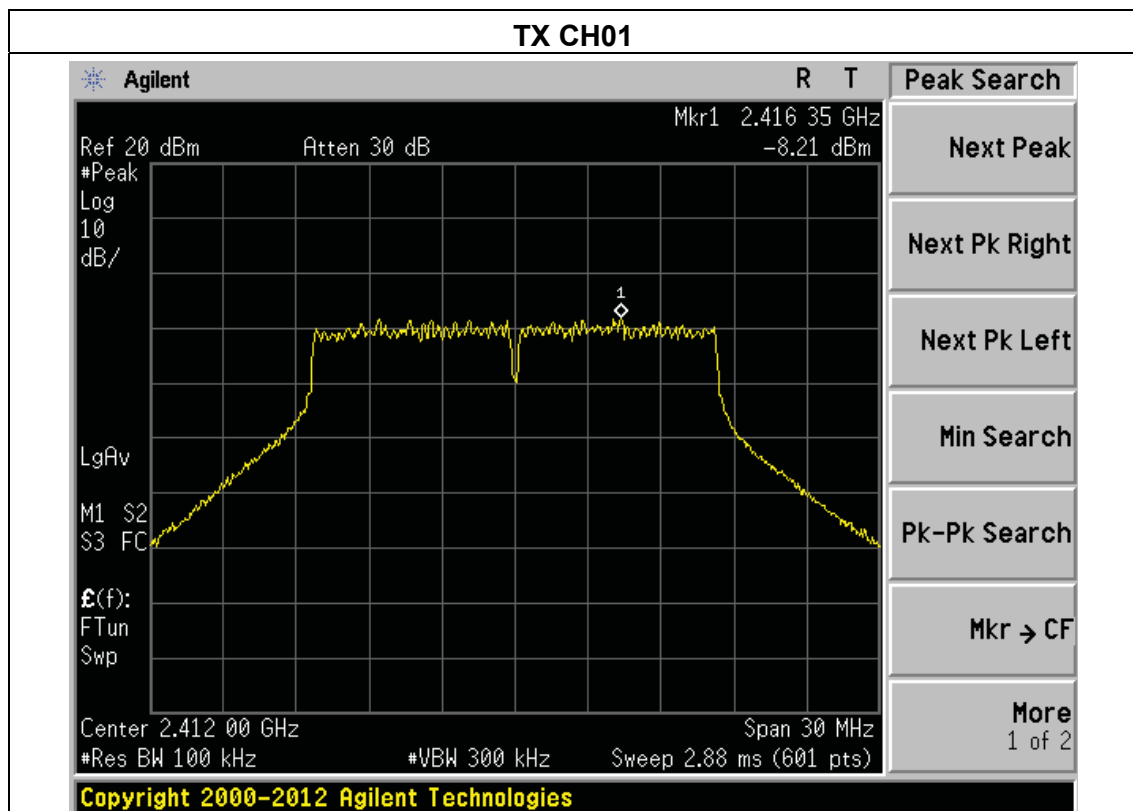

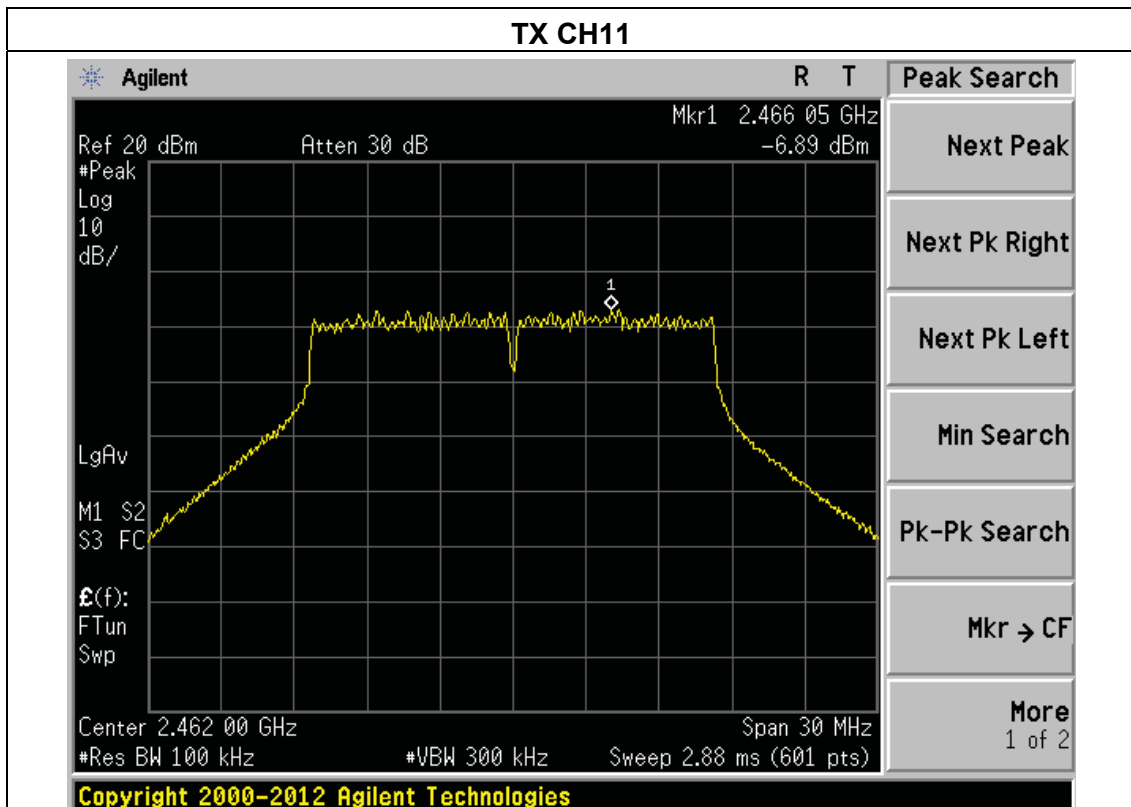
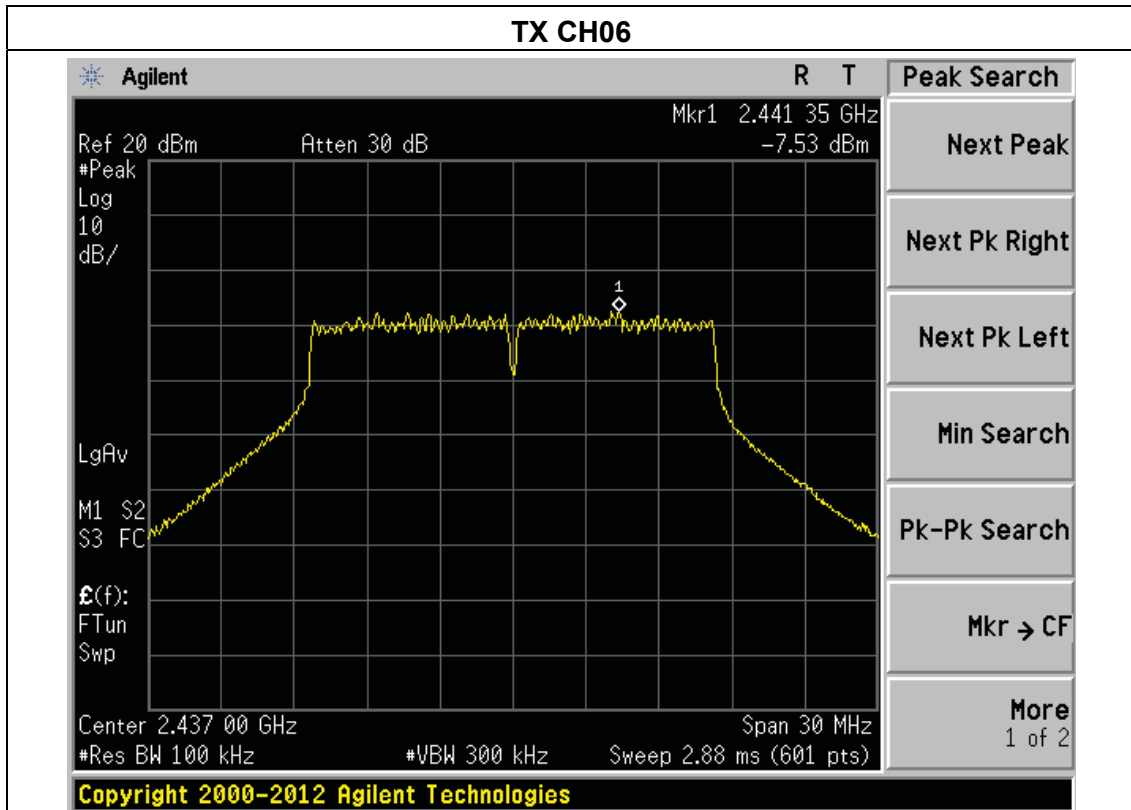



Temperature :	25°C	Relative Humidity :	60%
Pressure :	1015 hPa	Test Voltage :	DC 11.4V
Test Mode :	TX n Mode(20M)		

Frequency	Power Spectral Density(dBm)	Limit (dBm)	Result
2412 MHz	-10.12	8	PASS
2437 MHz	-9.22	8	PASS
2462 MHz	-8.07	8	PASS

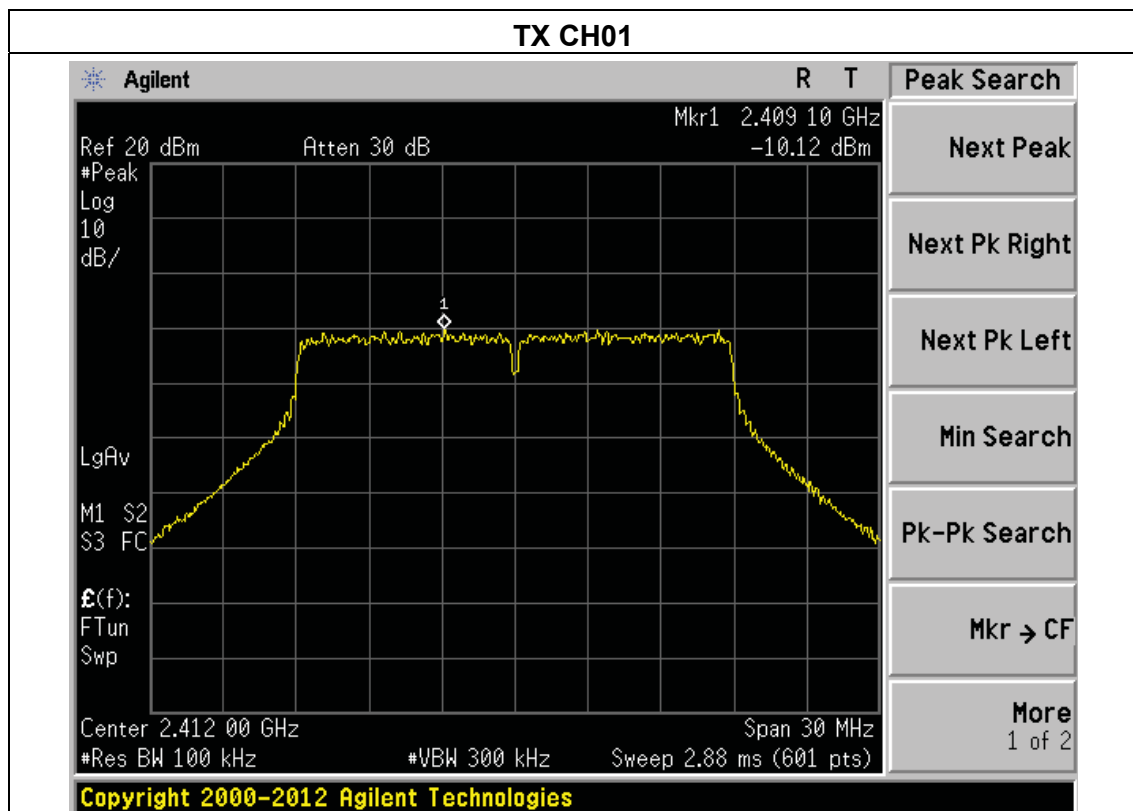

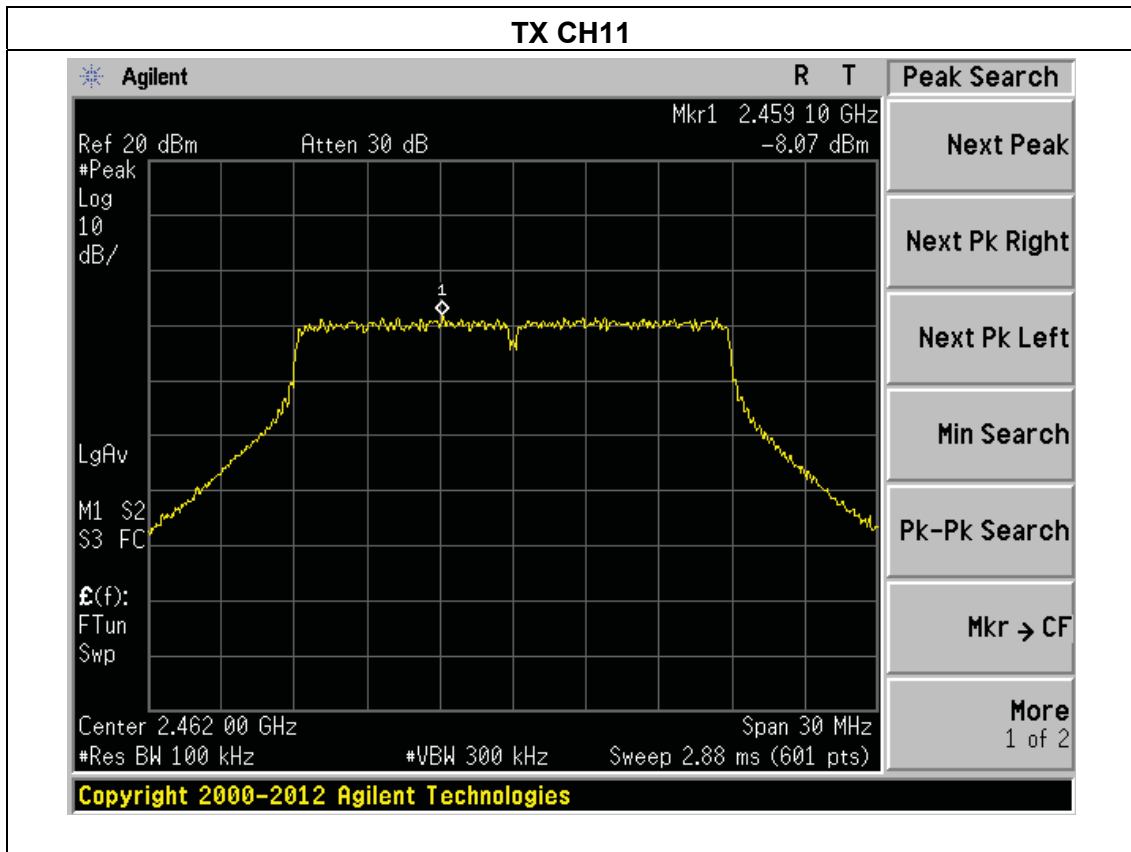
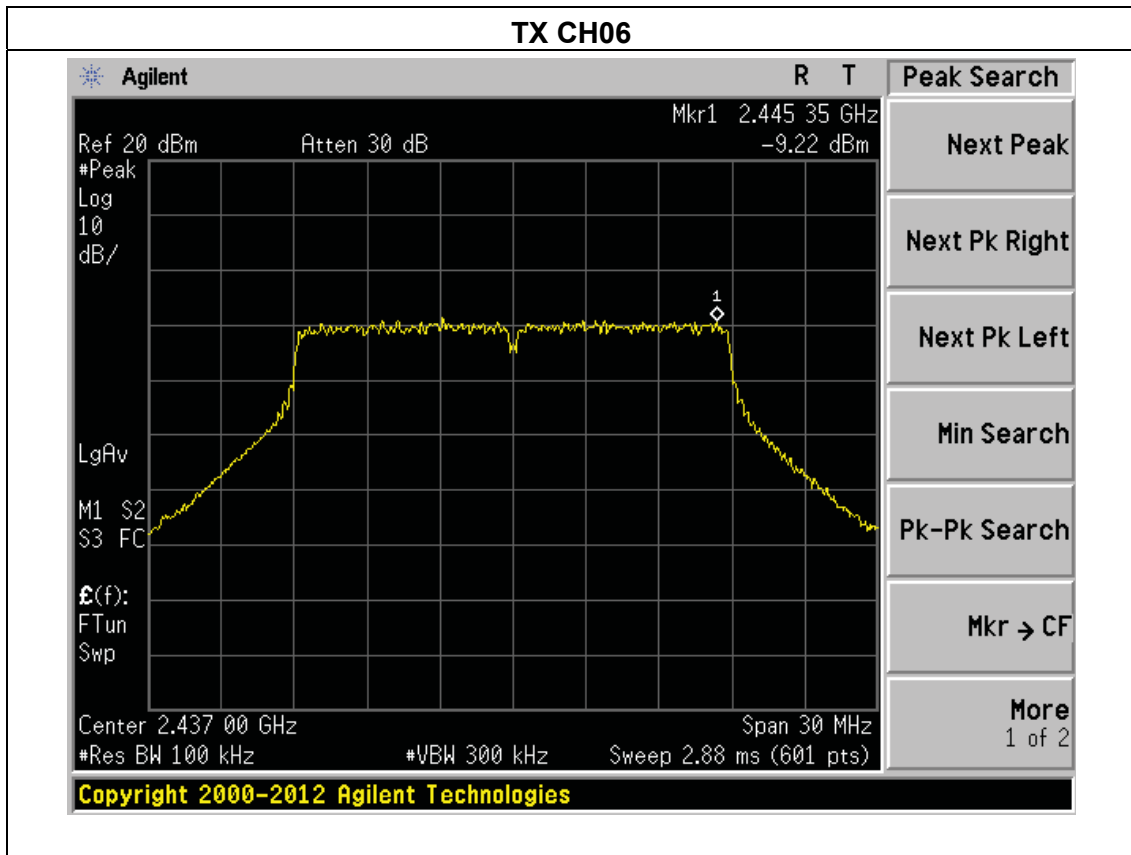



Temperature :	25°C	Relative Humidity :	60%
Pressure :	1015 hPa	Test Voltage :	DC 11.4V
Test Mode :	TX n Mode(40M)		

Frequency	Power Spectral Density(dBm)	Limit (dBm)	Result
2422 MHz	-13.09	8	PASS
2437 MHz	-12.65	8	PASS
2452 MHz	-12.25	8	PASS

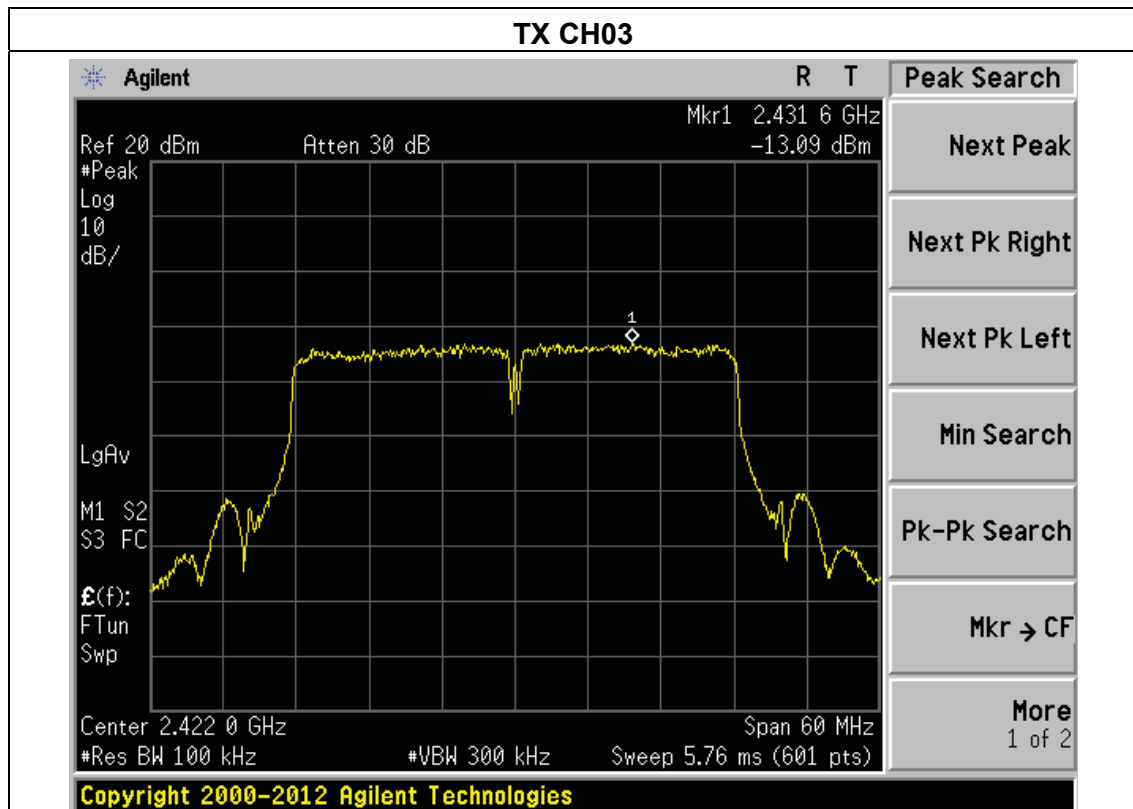

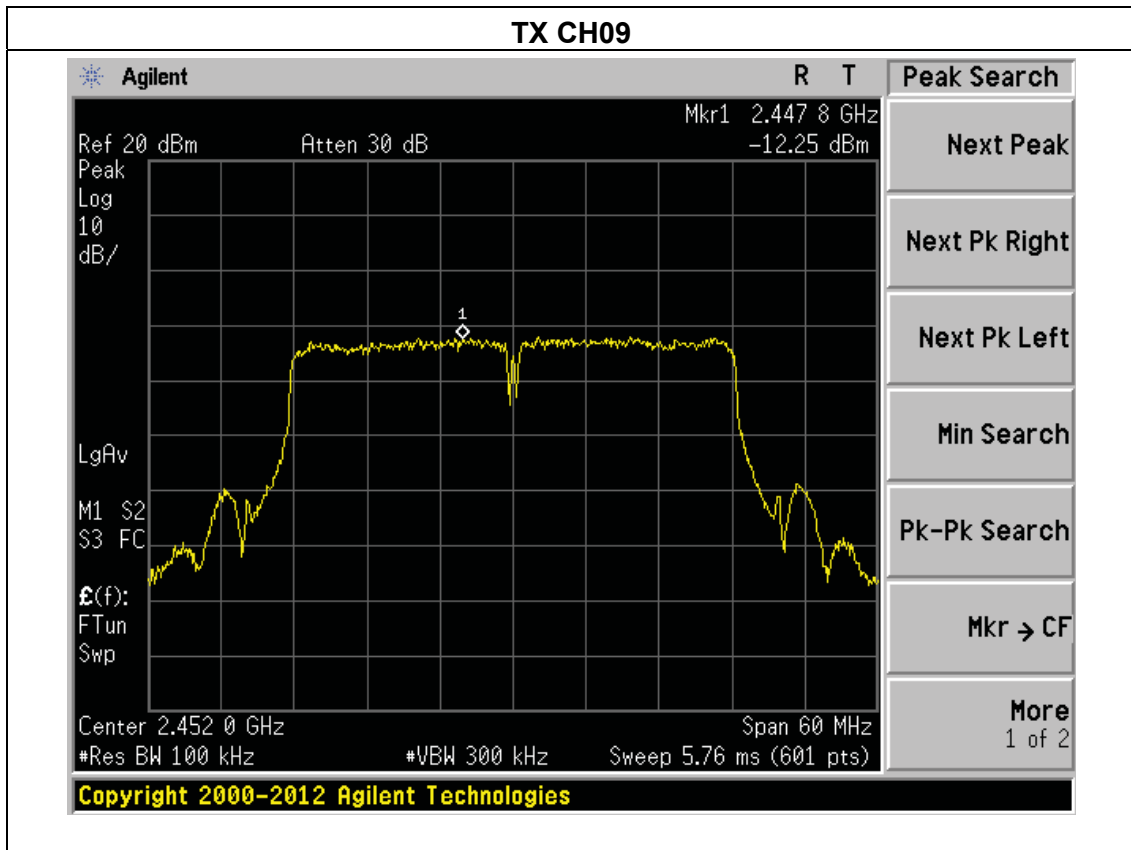
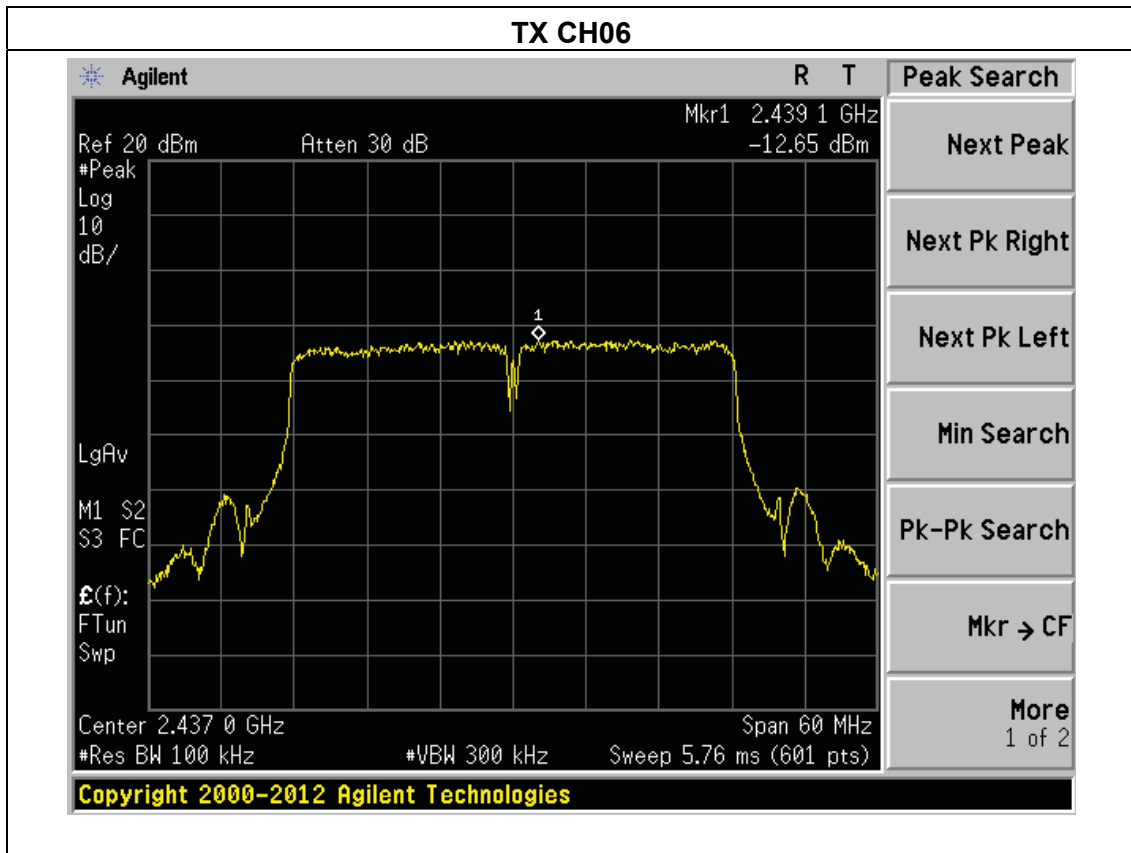



5. BANDWIDTH TEST

5.1 APPLIED PROCEDURES / LIMIT

FCC Part15 (15.247) , Subpart C				
Section	Test Item	Limit	Frequency Range (MHz)	Result
15.247(a)(2)	Bandwidth	$\geq 500\text{KHz}$ (6dB bandwidth)	2400-2483.5	PASS

5.1.1 TEST PROCEDURE

1. Set RBW = 100 kHz.
2. Set the video bandwidth (VBW) $\geq 3 \times$ RBW.
3. Detector = Peak.
4. Trace mode = max hold.
5. Sweep = auto couple.
6. Allow the trace to stabilize.
7. Measure the maximum width of the emission that is constrained by the frequencies associated with the two outermost amplitude points (upper and lower frequencies) that are attenuated by 6 dB relative to the maximum level measured in the fundamental emission.

5.1.2 DEVIATION FROM STANDARD

No deviation.

5.1.3 TEST SETUP



5.1.4 EUT OPERATION CONDITIONS

The EUT tested system was configured as the statements of 2.4 Unless otherwise a special operating condition is specified in the follows during the testing.



5.1.5 TEST RESULTS

Temperature :	25°C	Relative Humidity :	60%
Pressure :	1012 hPa	Test Voltage :	DC 11.4V
Test Mode :	TX b Mode		

Frequency (MHz)	6dB bandwidth (MHz)	Limit (kHz)	Result
2412	10.097	500	Pass
2437	10.096	500	Pass
2462	10.078	500	Pass

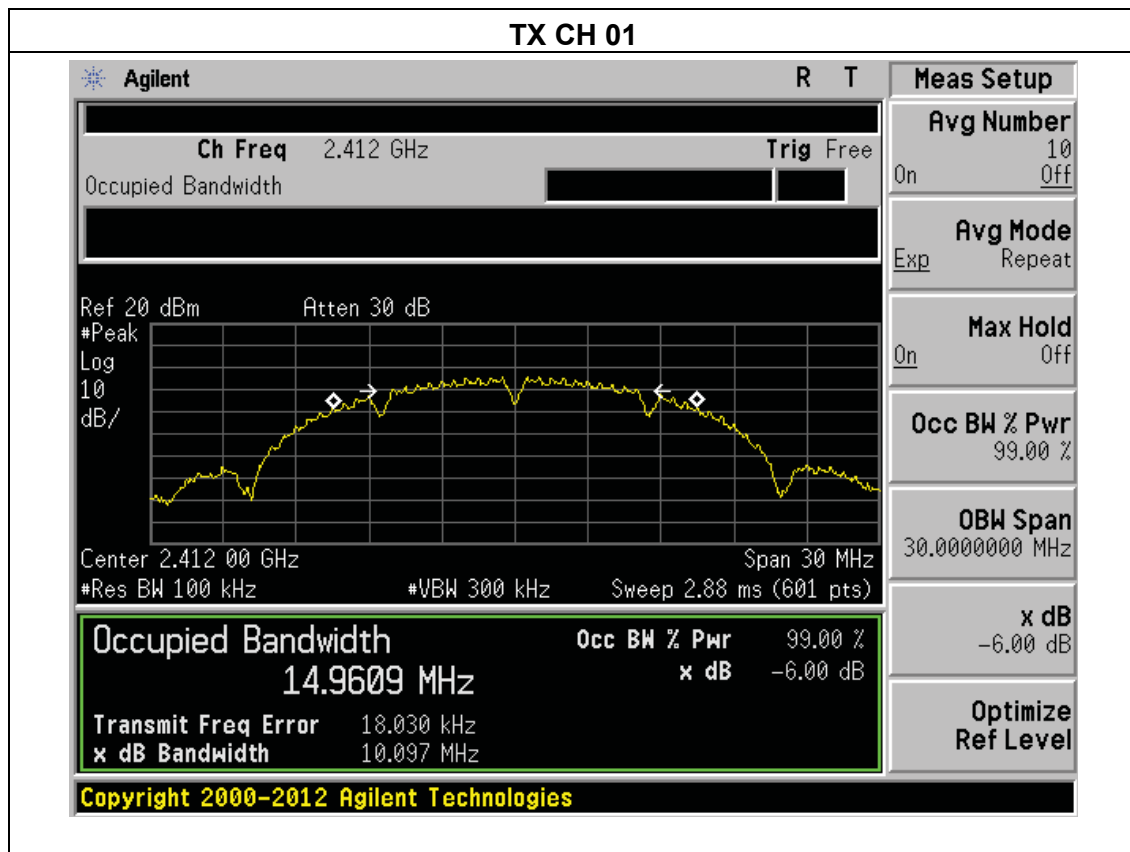

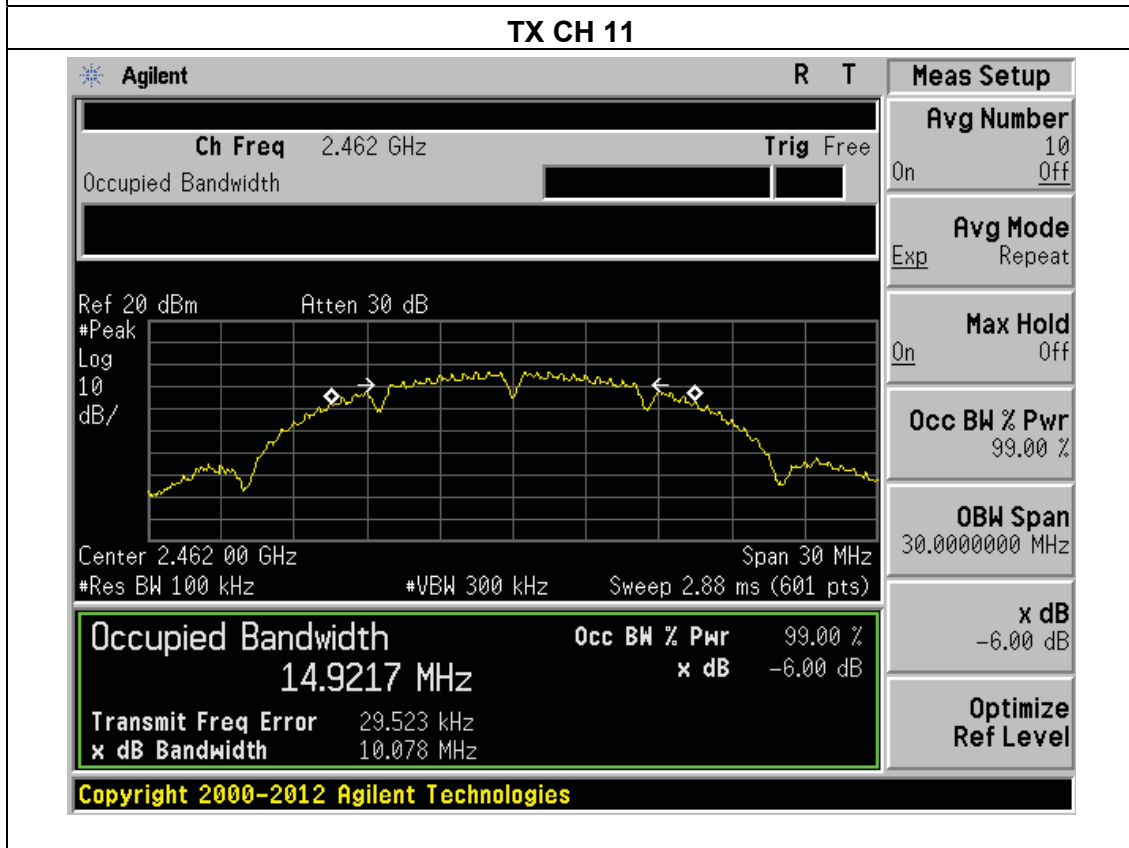
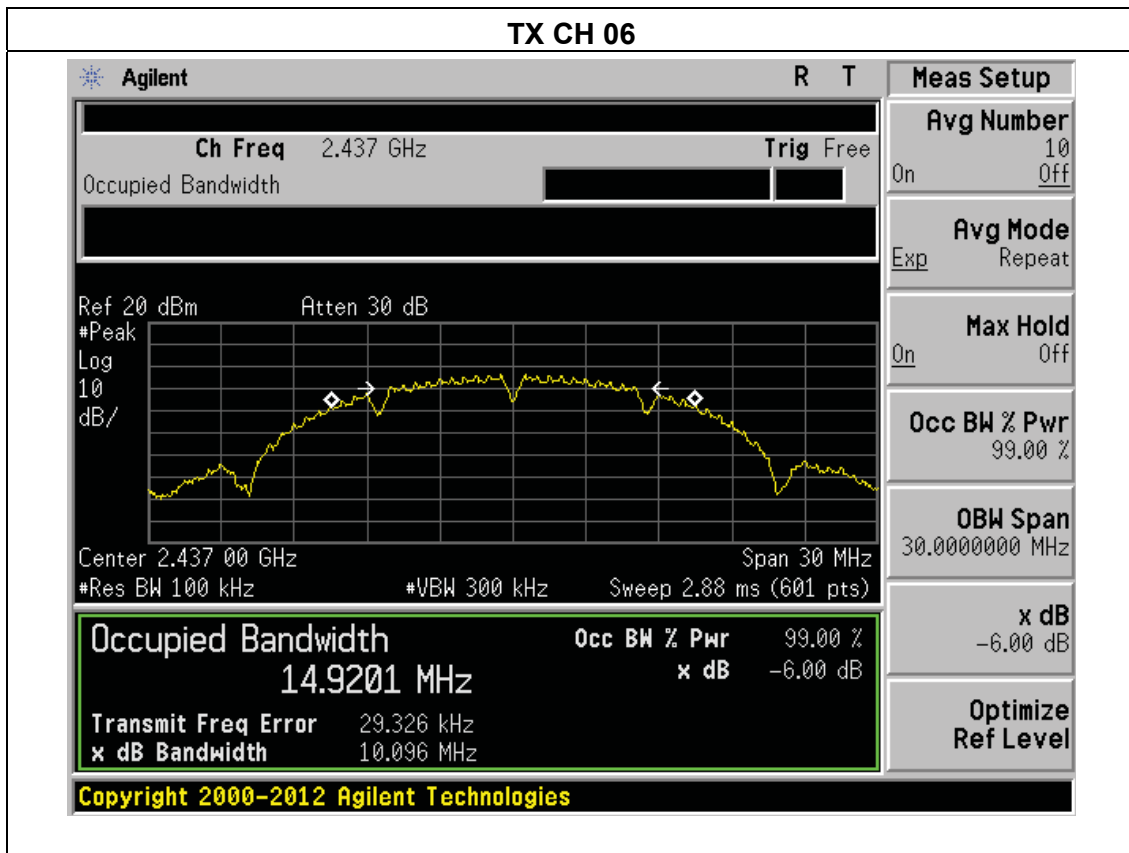



Temperature :	25°C	Relative Humidity :	60%
Pressure :	1012 hPa	Test Voltage :	DC 11.4V
Test Mode :	TX g Mode		

Frequency (MHz)	6dB bandwidth (MHz)	Limit (kHz)	Result
2412	16.575	500	Pass
2437	16.575	500	Pass
2462	16.583	500	Pass

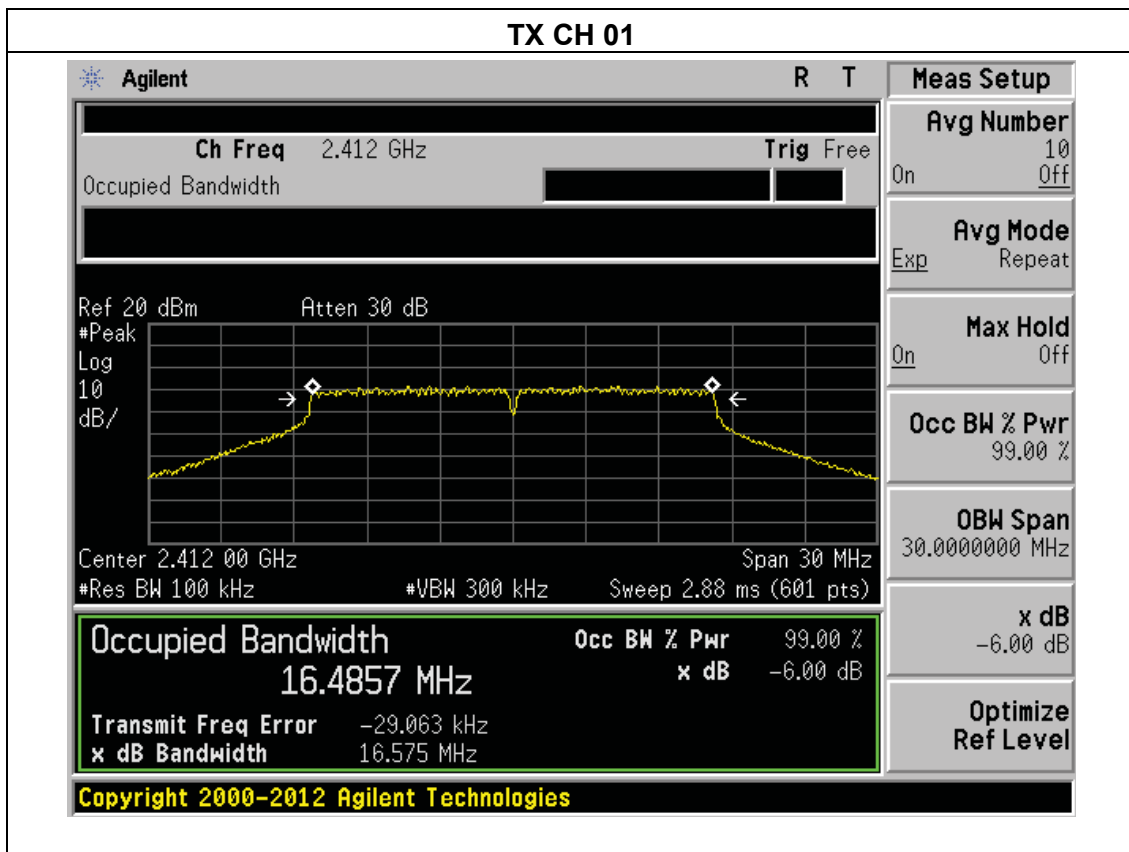

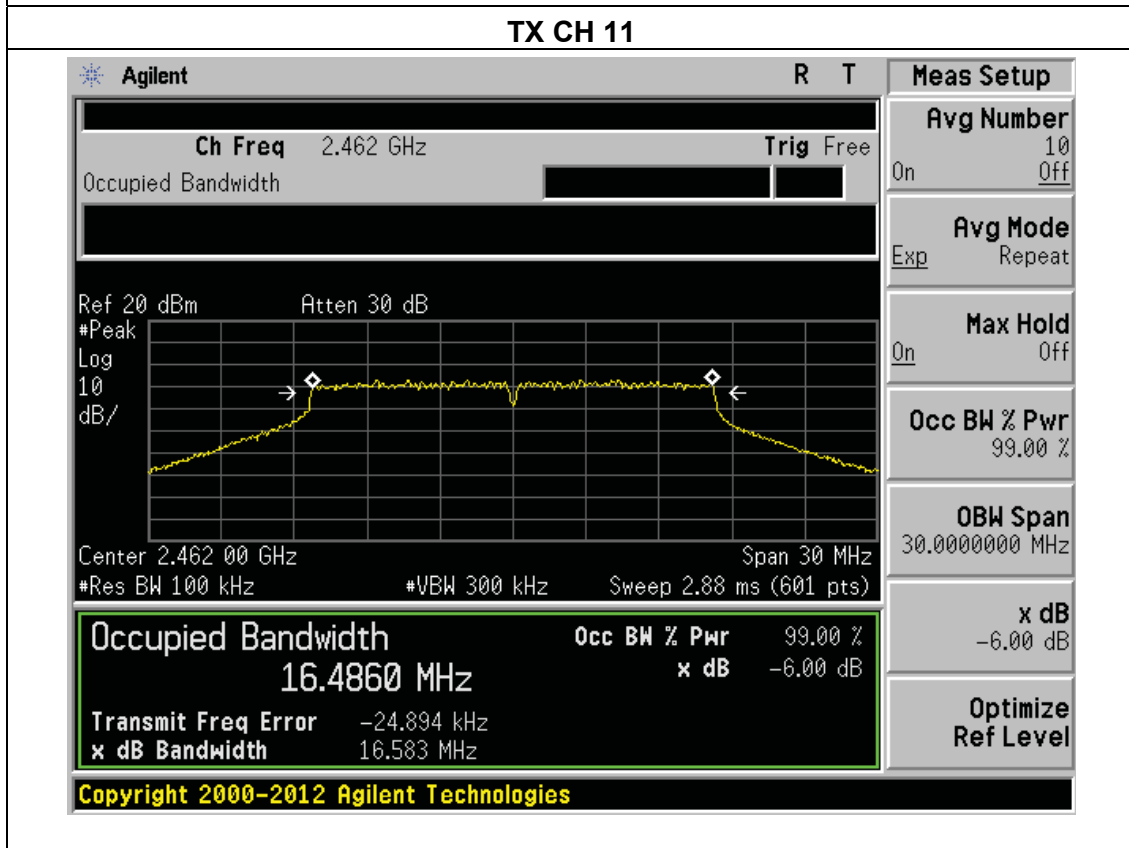
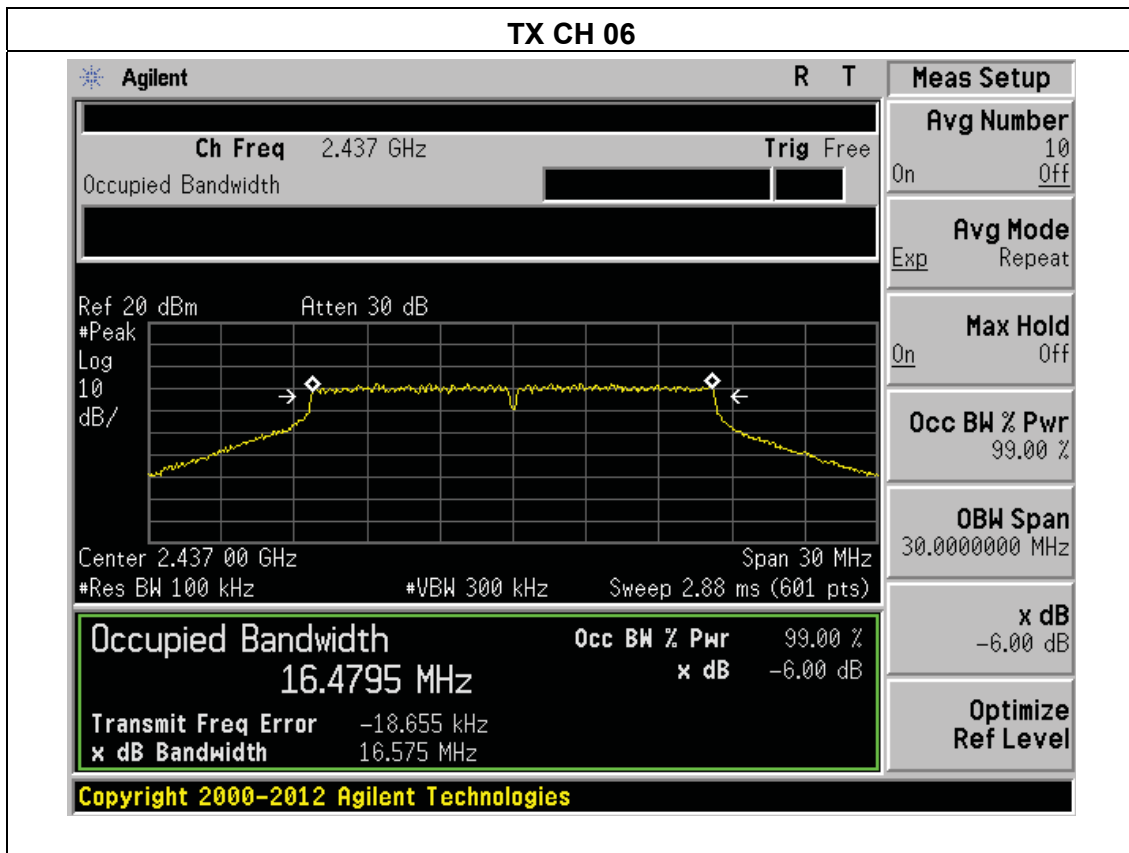



Temperature :	25°C	Relative Humidity :	60%
Pressure :	1012 hPa	Test Voltage :	DC 11.4V
Test Mode :	TX n Mode(20M)		

Frequency (MHz)	6dB bandwidth (MHz)	Limit (kHz)	Result
2412	17.863	500	Pass
2437	17.849	500	Pass
2462	17.860	500	Pass

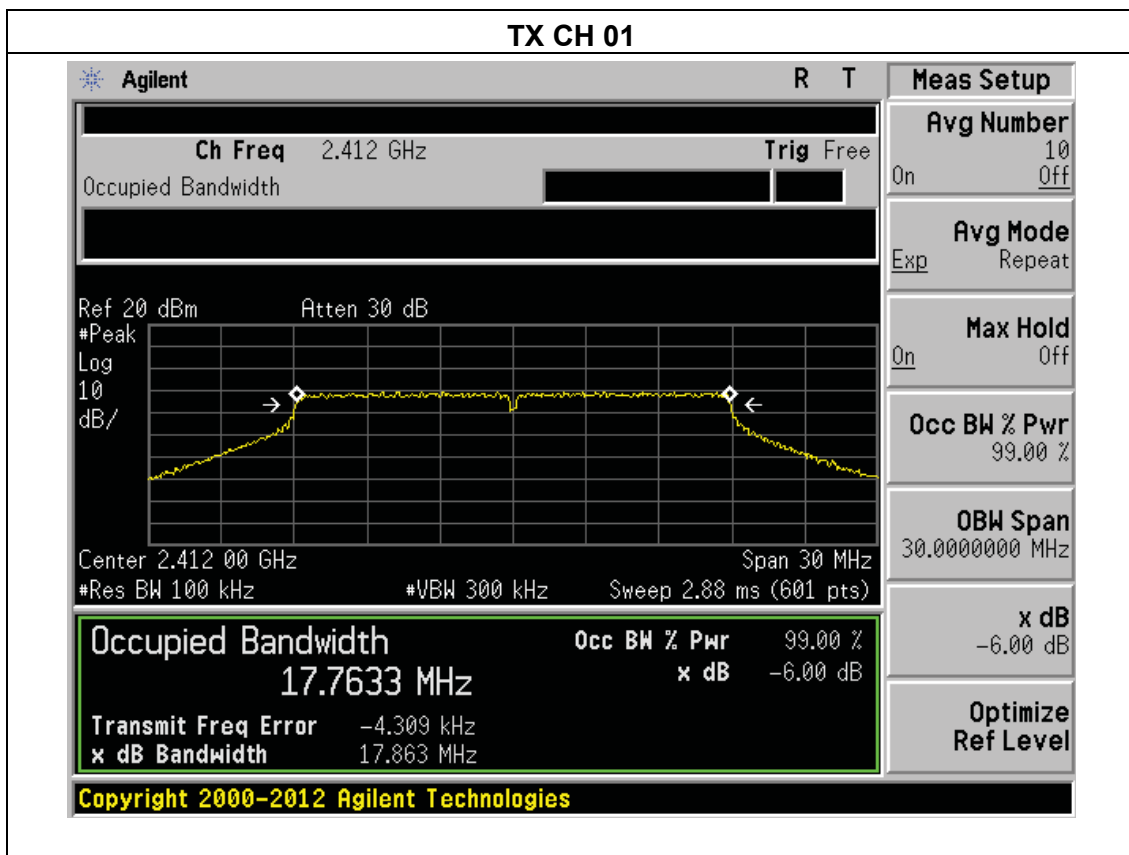

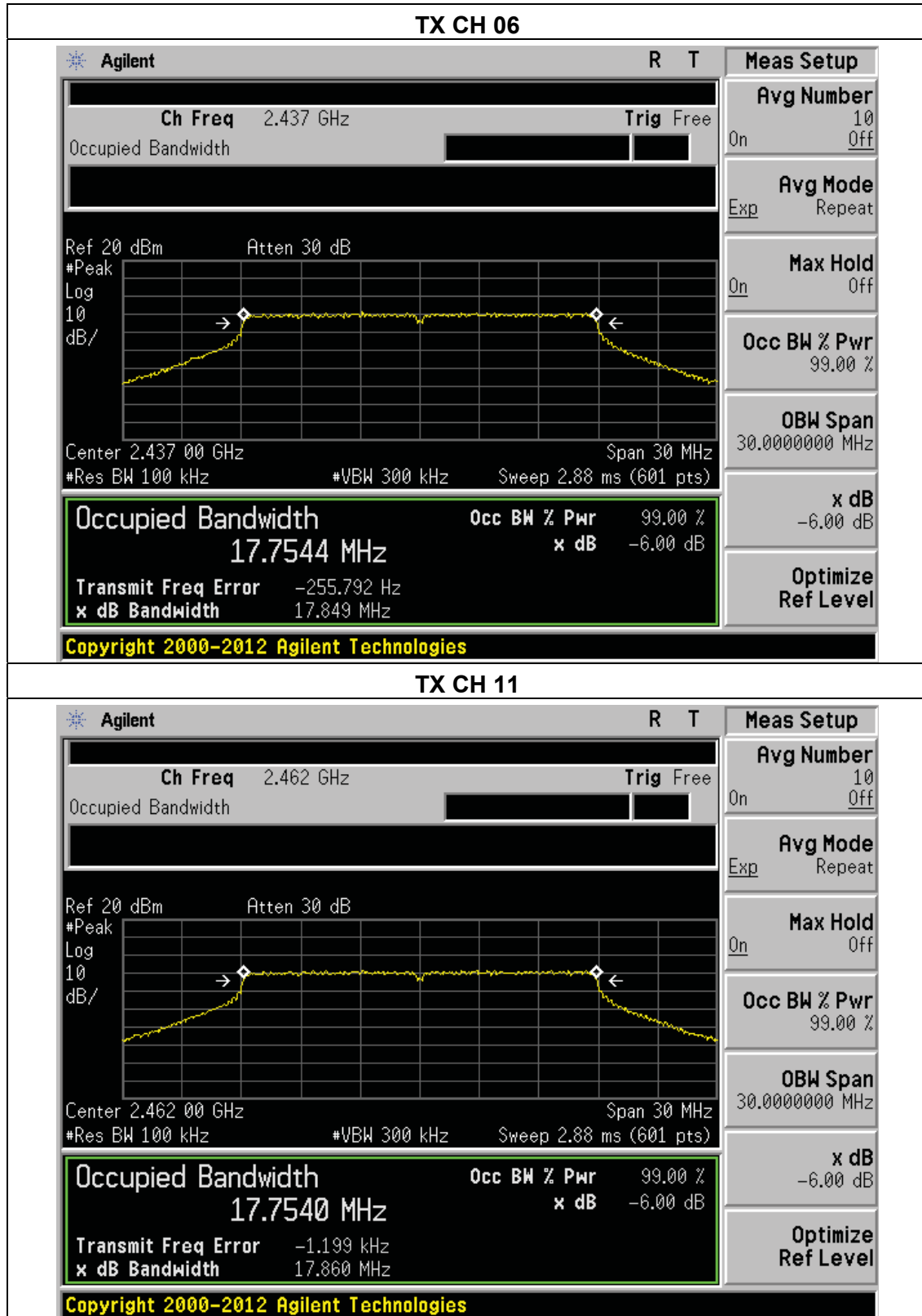



Temperature :	25°C	Relative Humidity :	60%
Pressure :	1012 hPa	Test Voltage :	DC 11.4V
Test Mode :	TX n Mode(40M)		

Frequency (MHz)	6dB bandwidth (MHz)	Limit (kHz)	Result
2422	36.484	500	Pass
2437	36.498	500	Pass
2452	36.488	500	Pass

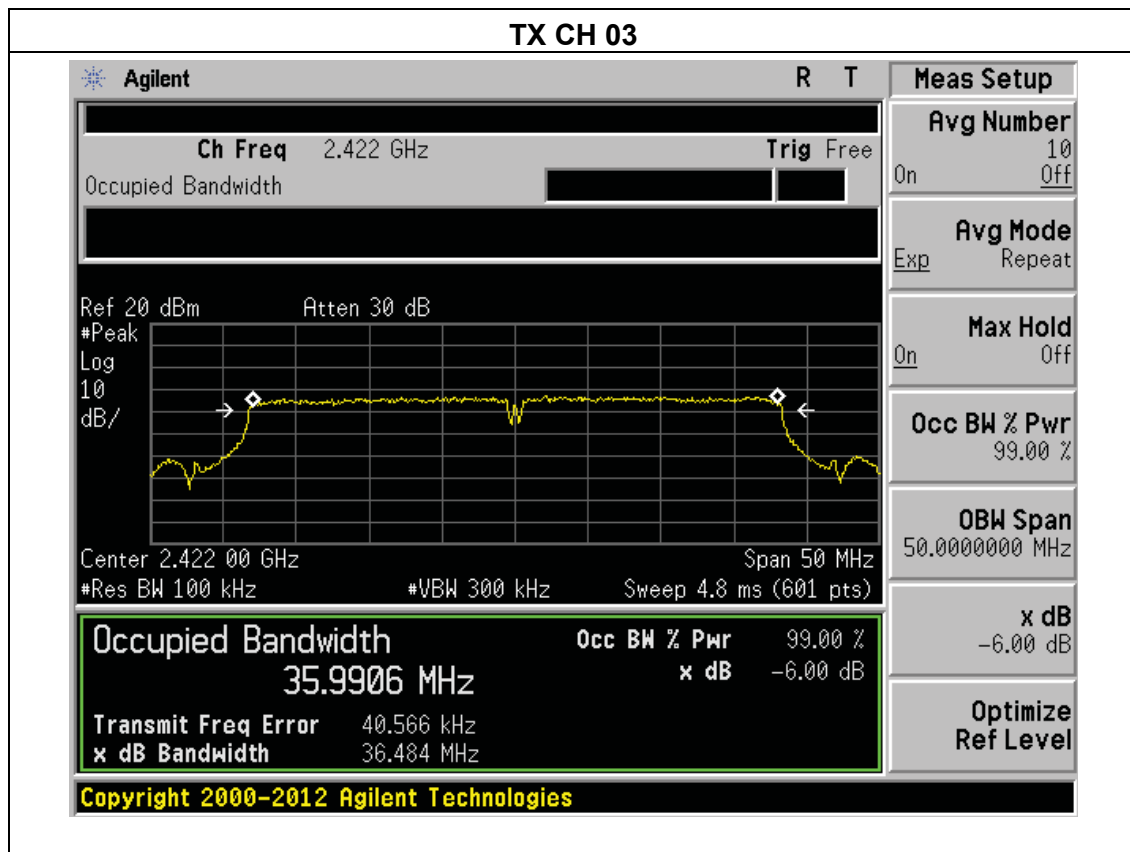

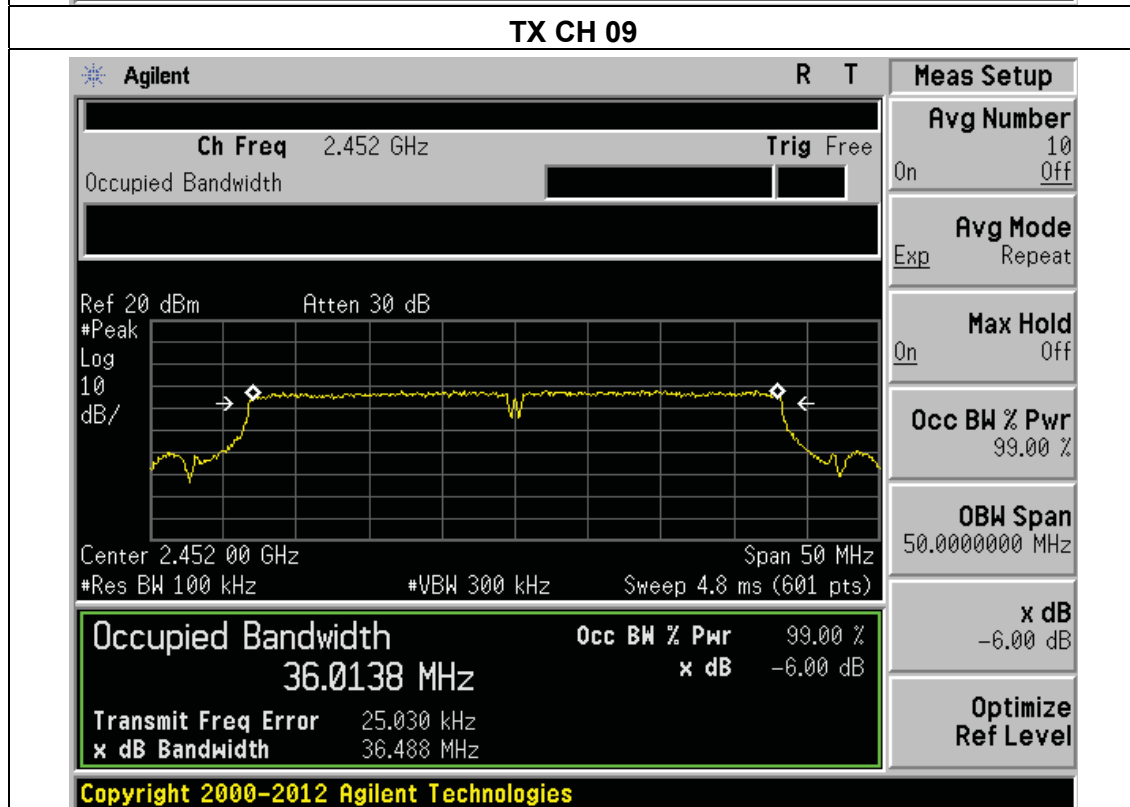
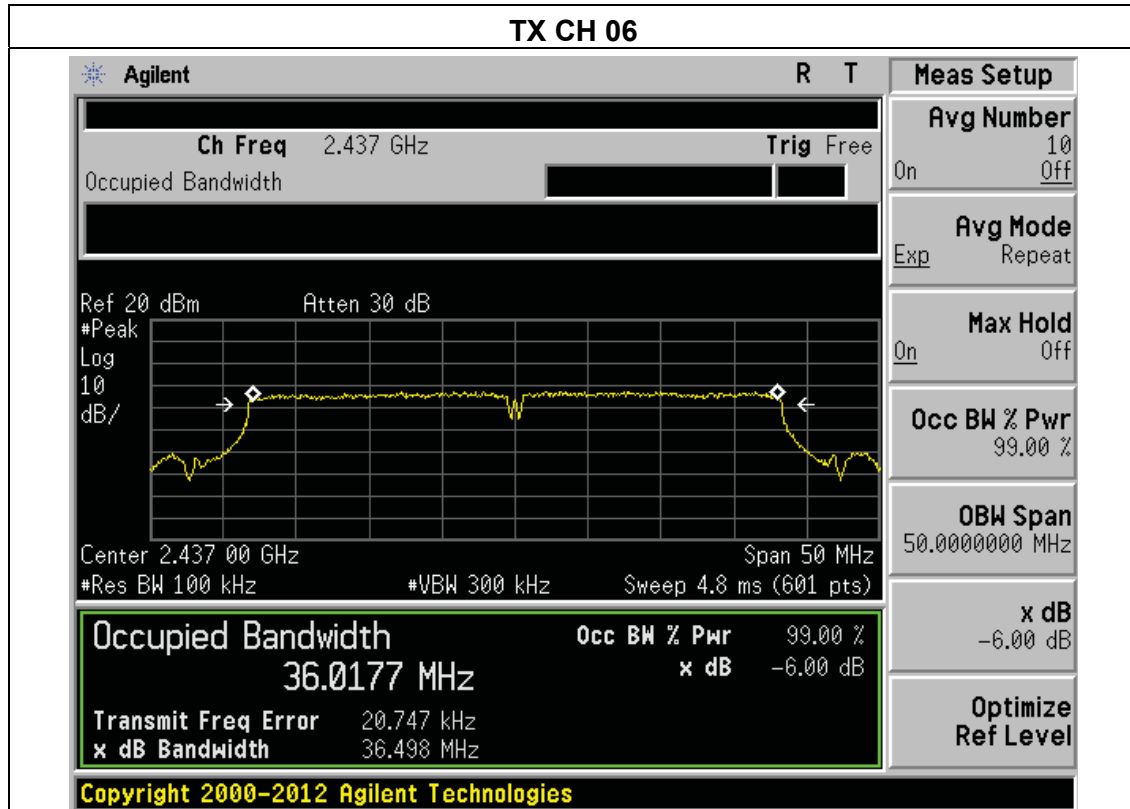



6. PEAK OUTPUT POWER TEST

6.1 APPLIED PROCEDURES / LIMIT

FCC Part15 (15.247) , Subpart C				
Section	Test Item	Limit	Frequency Range (MHz)	Result
15.247(b)(3)	Peak Output Power	1 watt or 30dBm	2400-2483.5	PASS

6.1.1 TEST PROCEDURE

- a. The EUT was directly connected to the Power meter

6.1.2 DEVIATION FROM STANDARD

No deviation.

6.1.3 TEST SETUP



6.1.4 EUT OPERATION CONDITIONS

The EUT tested system was configured as the statements of 2.4 Unless otherwise a special operating condition is specified in the follows during the testing.

**6.1.5 TEST RESULTS**

Temperature :	25°C	Relative Humidity :	60%
Pressure :	1012 hPa	Test Voltage :	DC 11.4V

	Frequency	Maximum Conducted Output Power(PK)	LIMIT
	(MHz)	(dBm)	dBm
802.11b	2412	16.35	30
	2437	16.38	30
	2462	16.36	30
802.11g	2412	14.26	30
	2437	14.24	30
	2462	14.26	30
802.11n20	2412	13.35	30
	2437	13.37	30
	2462	13.33	30
802.11n40	2422	12.57	30
	2437	12.74	30
	2452	12.67	30



7. 100 KHZ BANDWIDTH OF FREQUENCY BAND EDGE

7.1 APPLICABLE STANDARD

In any 100 kHz bandwidth outside the frequency band in which the spread spectrum intentional radiator is operating, the radio frequency power that is produced by the intentional radiator shall be at least 20 dB below that in the 100 kHz bandwidth within the band that contains the highest level of the desired power, based on either an RF conducted or a radiated measurement.

7.2 TEST PROCEDURE

- a) Check the calibration of the measuring instrument using either an internal calibrator or a known signal from an external generator.
- b) Position the EUT without connection to measurement instrument. Turn on the EUT and connect its antenna terminal to measurement instrument via a low loss cable. Then set it to any one measured frequency within its operating range, and make sure the instrument is operated in its linear range.
- c) Set RBW to 100 kHz and VBW of spectrum analyzer to 300 kHz with a convenient frequency span including 100 kHz bandwidth from band edge.
- d) Measure the highest amplitude appearing on spectral display and set it as a reference level. Plot the graph with marking the highest point and edge frequency.
- e) Repeat above procedures until all measured frequencies were complete.

7.3 DEVIATION FROM STANDARD

No deviation.

7.4 TEST SETUP

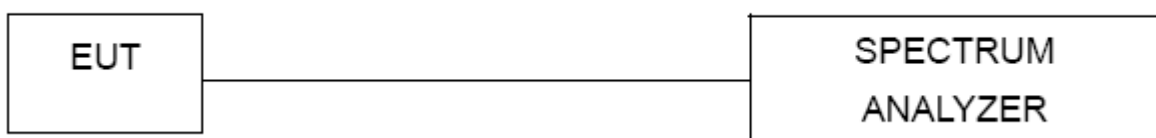

7.5 EUT OPERATION CONDITIONS

The EUT tested system was configured as the statements of 2.4 Unless otherwise a special operating condition is specified in the follows during the testing.

7.1 TEST RESULTS



802.11b: Band Edge, Left Side

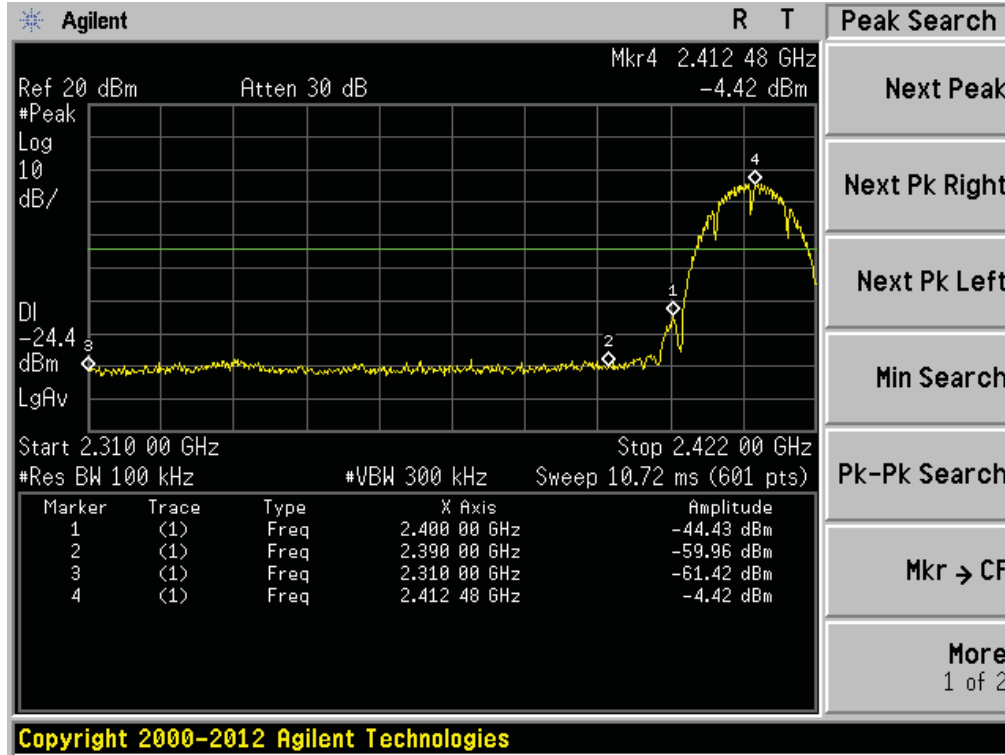

802.11b: Band Edge, Right Side

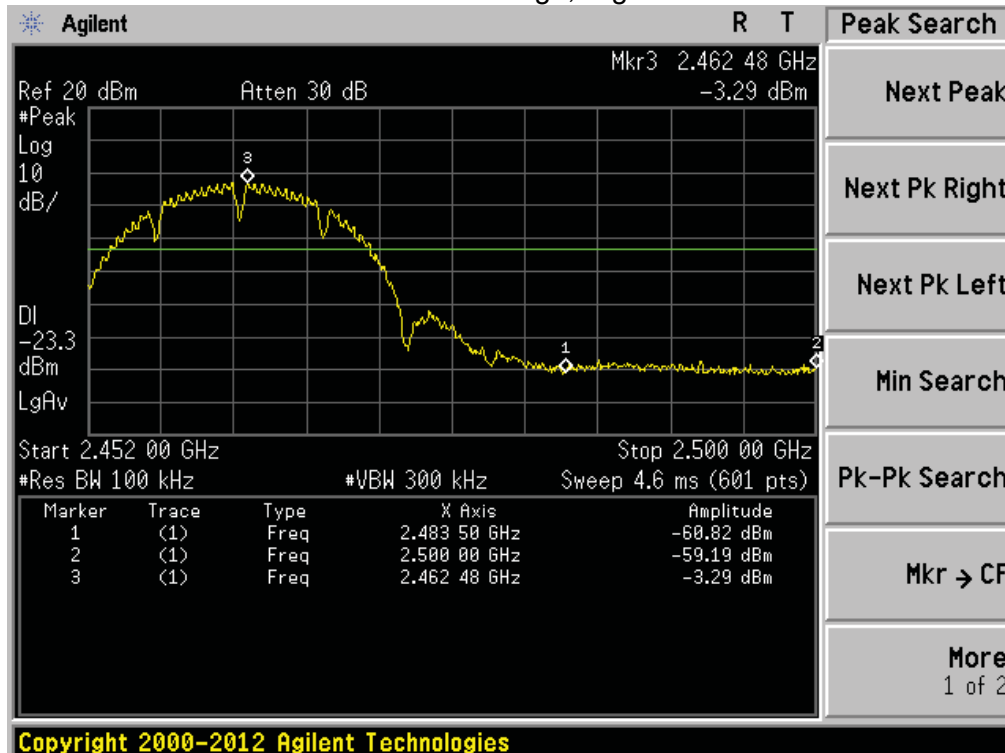



802.11g: Band Edge, Left Side

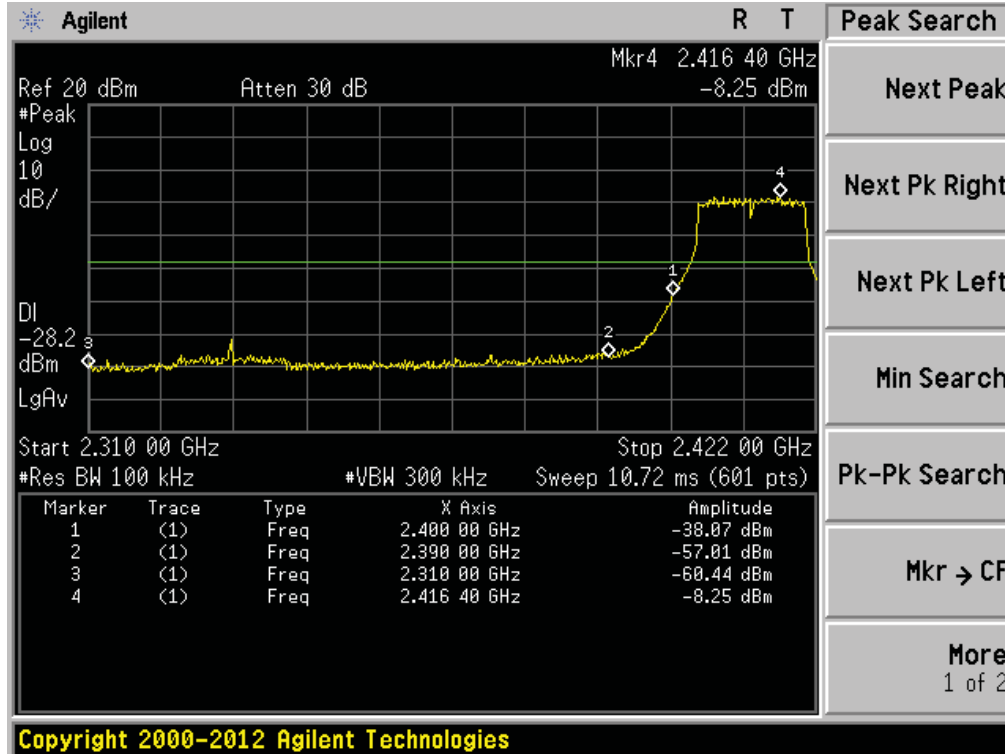

802.11g: Band Edge, Right Side

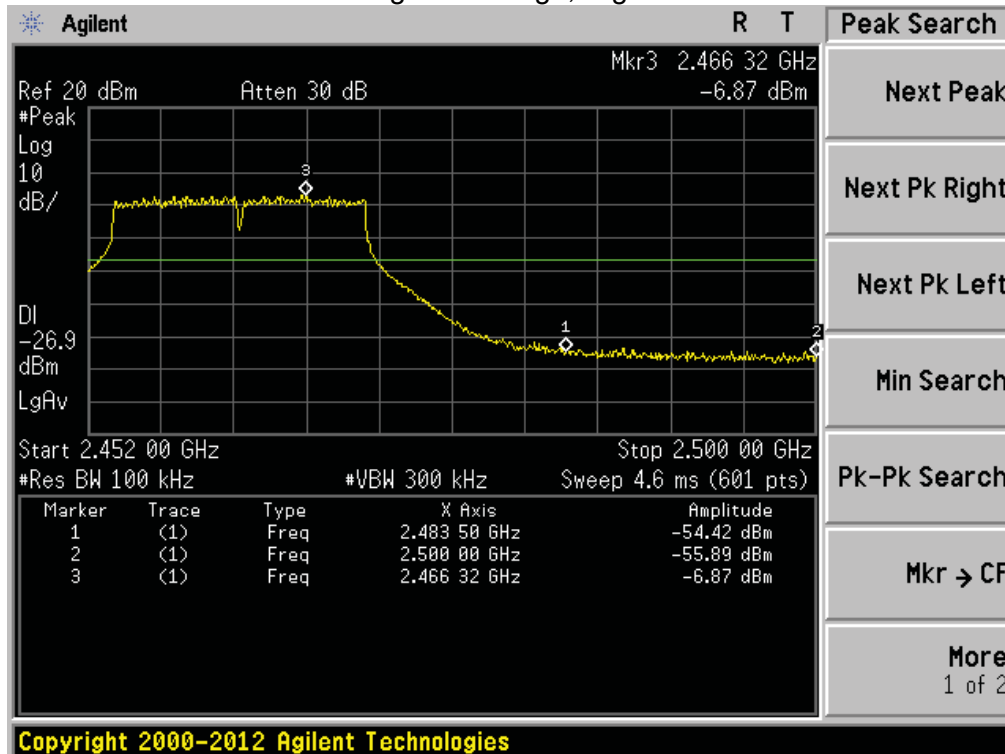



802.11n-HT20: Band Edge, Left Side

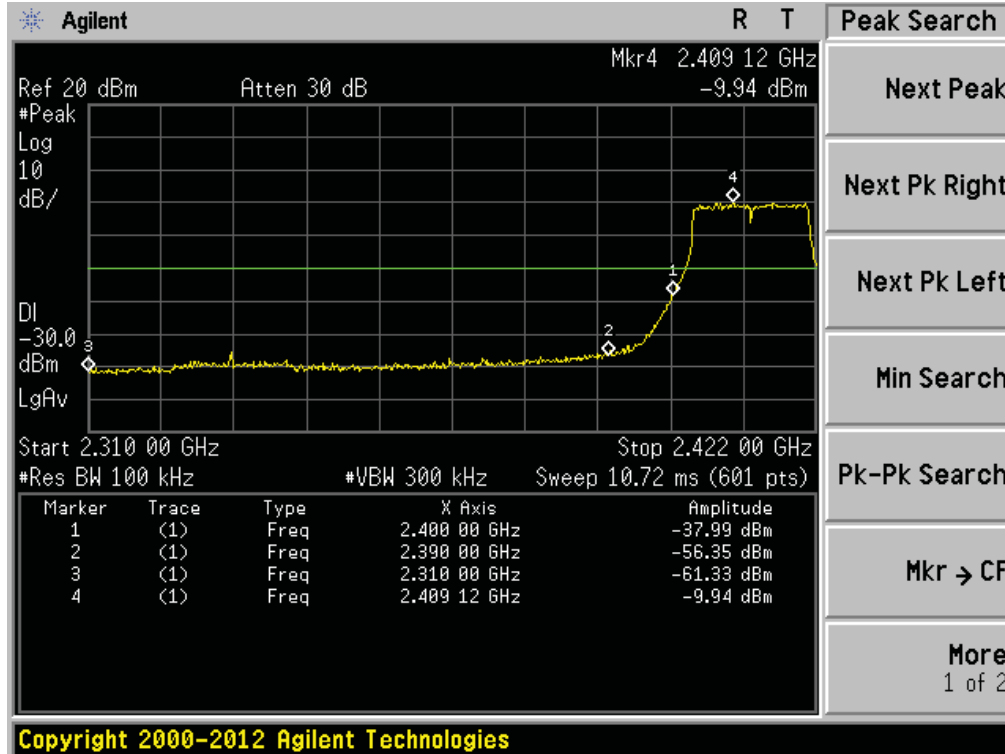

802.11n-HT20: Band Edge, Right Side

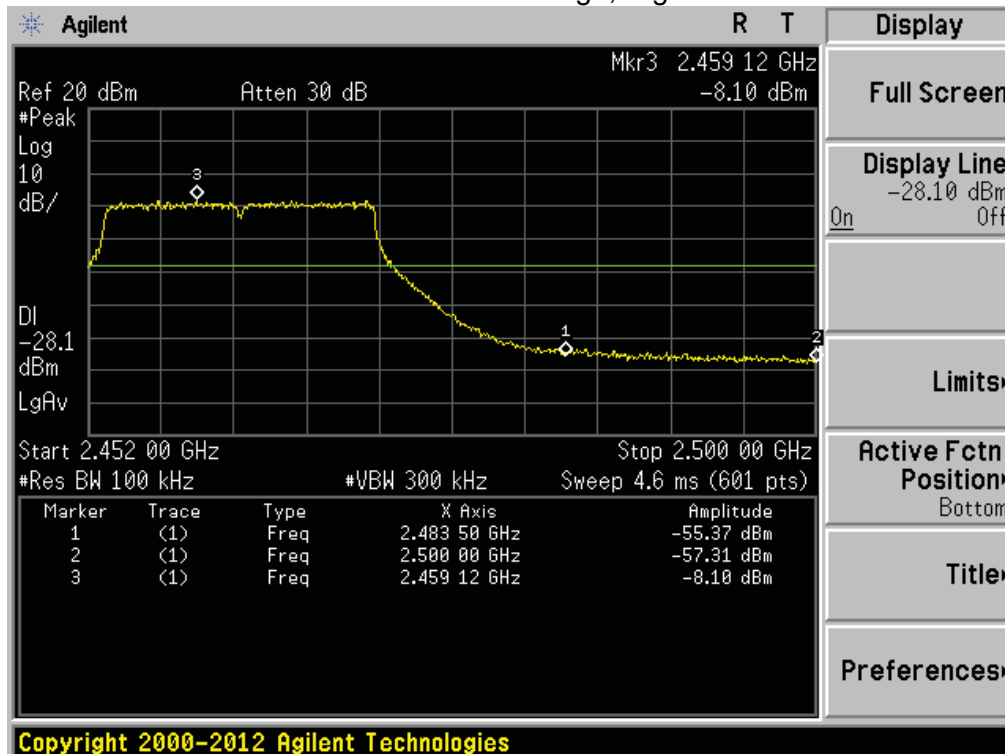



802.11n-HT40: Band Edge, Left Side

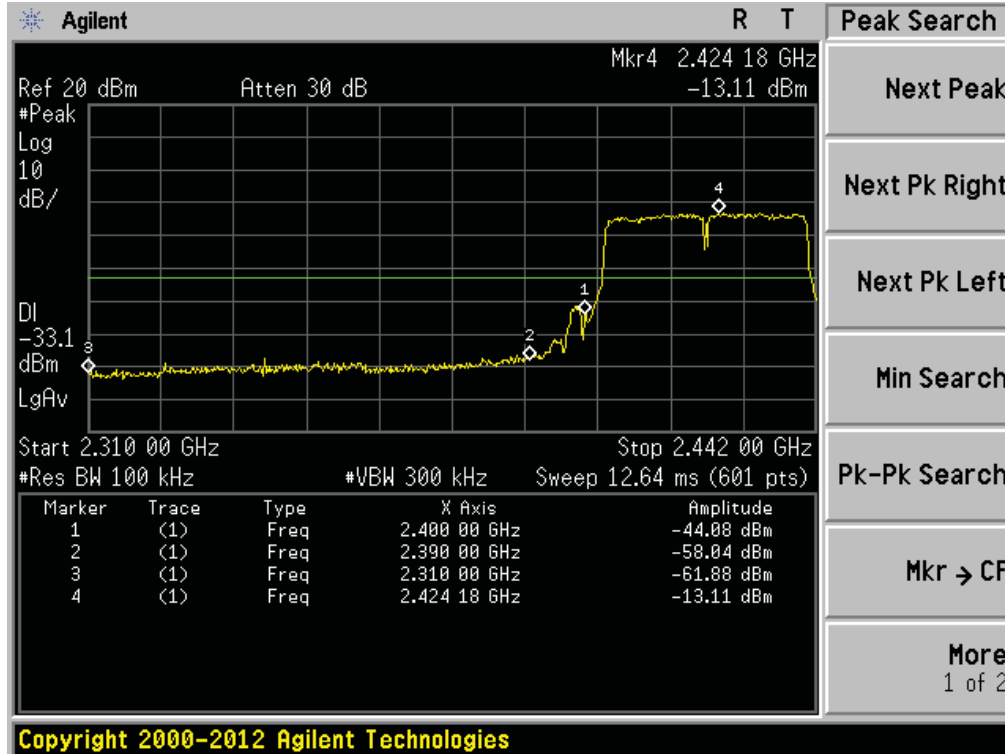

802.11n-HT40: Band Edge, Right Side

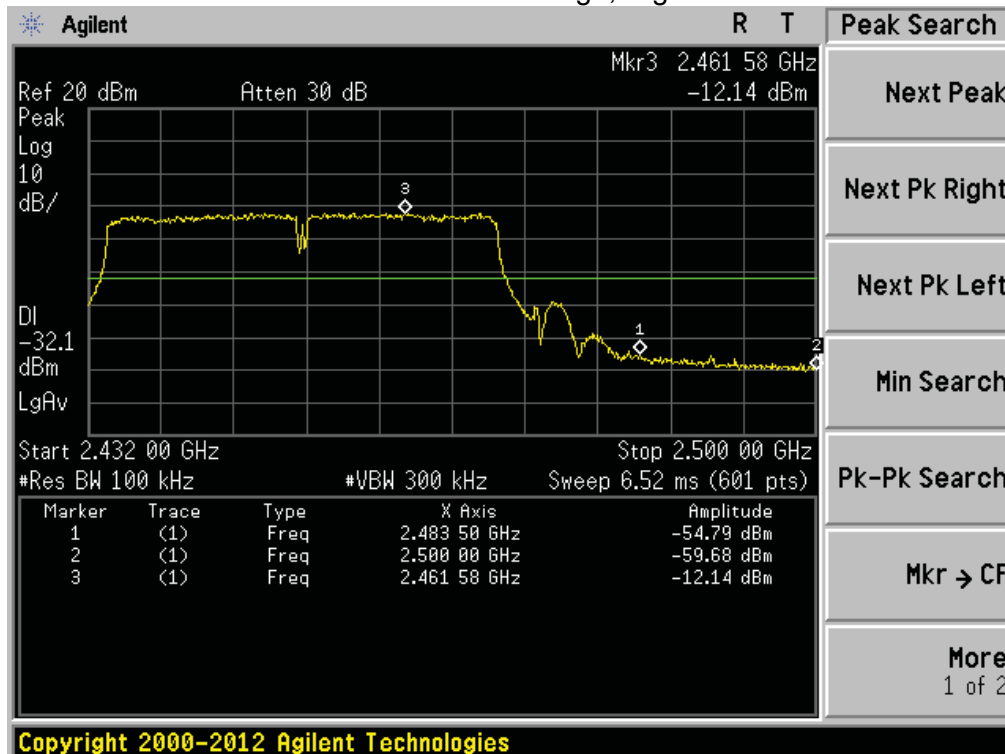



8. ANTENNA REQUIREMENT

8.1 STANDARD REQUIREMENT

15.203 requirement: For intentional device, according to 15.203: an intentional radiator shall be designed to ensure that no antenna other than that furnished by the responsible party shall be used with the device.

8.2 EUT ANTENNA

The EUT antenna is external antenna, and used reverse helix antenna, It comply with the standard requirement.

9. EUT TEST PHOTO

Radiated Measurement Photos



Radiated Measurement Photos

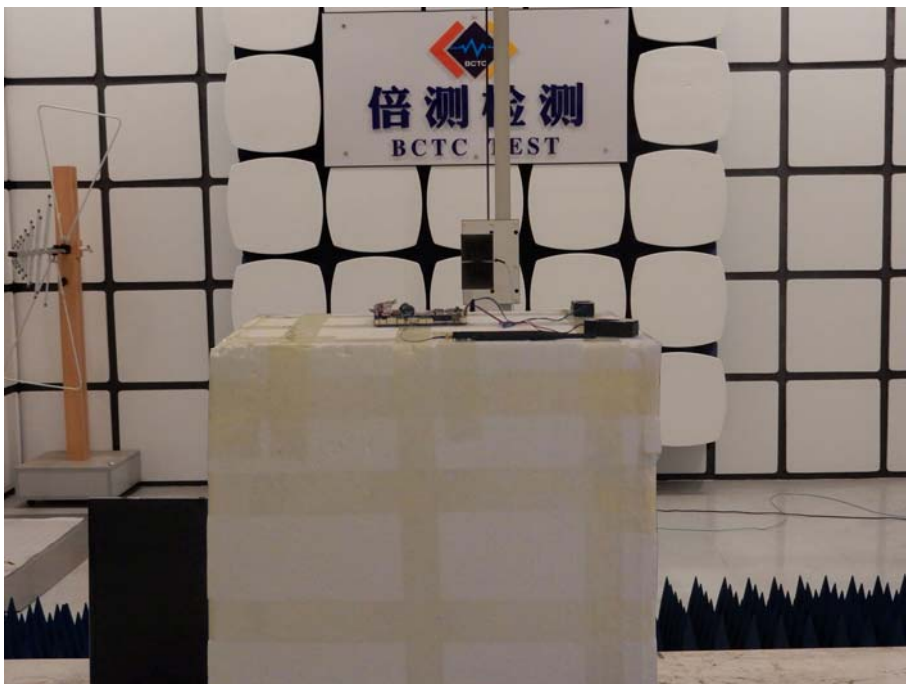



Conducted Measurement Photos



10. EUT PHOTO

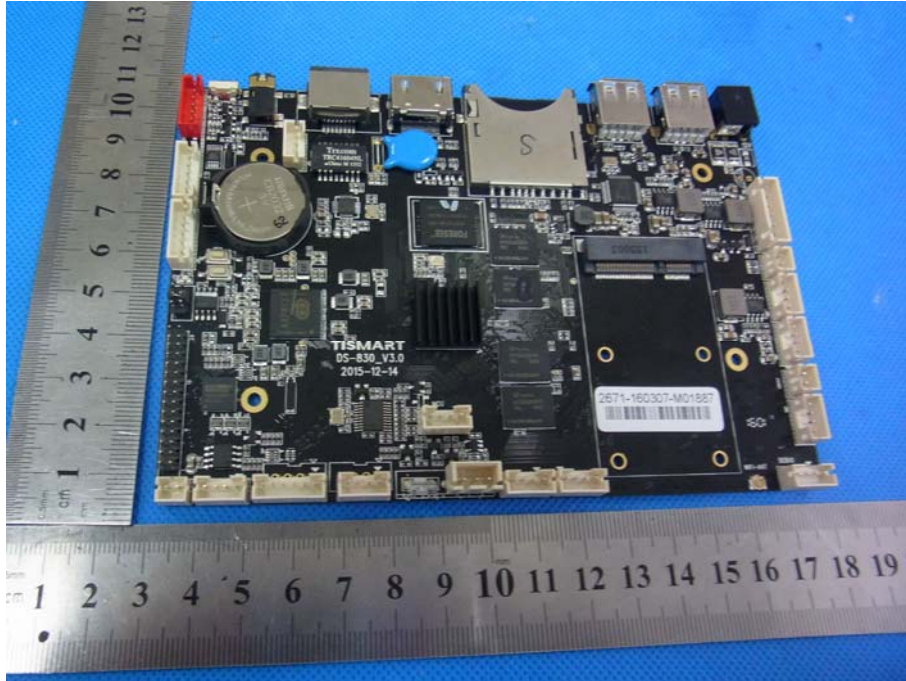

***** END OF REPORT *****