



UL Korea Ltd.
Korea.ul.com

Order No.: 11225652
Report No.: 16-11225652-FCC
Date: June 10, 2016
Model No.: OELD
FCC ID : 2AISEOELD
IC ID : 21613-OELD

FCC/IC Test Report

**in accordance with
FCC Part 15 Subpart C §15.247
IC RSS-247**

for

Smart Junction Box for Gas Detectors

**Honeywell Analytics Asia Pacific Co., Ltd.
7F SangAm IT Tower, 434 Worldcup Buk-ro, Mapo-gu,
Seoul 03922, South Korea**

Copyright © 2016 UL Korea Ltd.

UL Korea Ltd. authorizes the above-named company to reproduce this Report provided it is reproduced in its entirety.

Summary of Test Results:

The following tests were performed on a sample submitted for evaluation of compliance with FCC Part 15 C Section 15.247 and IC RSS-247, RSS-GEN

No	FCC Reference Clause No.	IC Reference Clause No.	Conformance Requirements	Result	Remark
1	15.247(a)(2)	RSS-247 5.2(1)	6 dB Bandwidth Occupied Bandwidth	Complied	-
2	15.247(b)(3)	RSS-247 5.4(4)	Maximum peak output power	Complied	-
3	15.247(e)	RSS-247 5.2(2)	Power spectral density	Complied	-
4	15.247(d)	RSS-247 5.5	Band Edge Conducted spurious emission	Complied	-
5	15.205(a) 15.209(a)	RSS-247 5.5 RSS-GEN 8.9	Radiated spurious emissions	Complied	-
6	15.207(a)	RSS-GEN 8.8	Transmitter AC power line conducted emission	N/A	Note 1

Note 1. The EUT is DC operating only.

Conclusion:

The tests listed above have been performed and the results recorded by UL Korea Ltd. in accordance with the procedures stated in each test requirement and specification. The test items were determined to ensure the requirements set out in the FCC CFR 47 Part 15 Subpart C §15.247 and RSS-247. As a result, the subject product has been verified to comply or not comply with each test specification. The test results relate only to the items tested.



Witness tested by
Jihoon Lee, WiSE Laboratory Engineer
Consumer Technology Division
UL Korea Ltd.
June 10, 2016



Reviewed by
Jeonghwan Kim, WiSE Laboratory Engineer
Consumer Technology Division
UL Korea Ltd.
June 10, 2016

Test Report Details

Witnessed By: UL Korea Ltd.
26th FL. GFC Center, 737 Yeoksam-dong, Gangnam-gu, Seoul, 135-984, Korea

Test Site: ENG Co., Ltd
135-60 Gyeongchungdae-ro, Gonjiam-eup, Gwangju-si, Gyeonggi-do, Korea
464-942

Applicant: Honeywell Analytics Asia Pacific Co., Ltd.
7F SangAm IT Tower, 434 Worldcup Buk-ro, Mapo-gu, Seoul 03922, South
Korea

Manufacturer: Honeywell Analytics Asia Pacific Co., Ltd.
7F SangAm IT Tower, 434 Worldcup Buk-ro, Mapo-gu, Seoul 03922, South
Korea

Factory: Honeywell Analytics Asia Pacific Co., Ltd.
28, 2gongdan 2-ro, Seobuk-gu, Cheonan-si, Chungcheongnam-do, Korea

Applicant Contact: Hyun mook Kim

Phone: 82-2-6909-0371

E-mail: hyunmook.kim@honeywell.com

Product Type: Smart Junction Box for Gas Detectors

Model Number: OELD

Multi Model Number: OELD B XXXXXX A DNU X
The manufacturer has declared to all the multiple model names into the basic
model without any further evaluation by UL.

Trademark **Honeywell**

Sample Serial Number: N/A

Test standards: FCC Part 15 C Section 15.247
Operation within the bands 902–928 MHz, 2400–2483.5 MHz,
and 5725–5850 MHz
IC RSS-247
Digital Transmission Systems (DTSs), Frequency Hopping Systems (FHSs) and
Licence-Exempt Local Area Network (LE-LAN) Devices

Sample Serial Number: N/A

Sample Receive Date: May 17, 2016

Testing Start Date: June 02, 2016

Testing Complete Date: June 08, 2016

Overall Results: **Pass**

The test reports apply only to the specific test samples and test results submitted for UL's review. All samples tested were in good operating condition throughout the entire test program. It is the manufacturer's responsibility to assure that additional production units of this model are manufactured with identical electrical and mechanical components. UL Korea Ltd. shall have no liability for any deductions, inferences or generalizations drawn by the client or others from UL Korea Ltd. issued reports. This report shall not be used to claim, constitute or imply product certification, approval, or any agency of the National Authorities. This report may contain test results that are not covered by the NVLAP or KOLAS accreditation.

Report Directory

1. GENERAL PRODUCT INFORMATION	5
1.1. EQUIPMENT DESCRIPTION	5
1.2. DETAILS OF TEST EQUIPMENT (EUT)	5
1.3. EQUIPMENT CONFIGURATION	5
1.4. TECHNICAL DATA.....	5
1.5. ANTENNA INFORMATION	5
1.6. EQUIPMENT TYPE :	6
1.7. TECHNICAL DESCRIPTIONS AND DOCUMENTS	6
1.8. EQUIPMENT MARKING PLATE.....	6
1.9. DESCRIPTION OF ADDITIONAL MODEL NAME.....	6
1.10. DUTY CYCLE.....	7
2. TEST SPECIFICATION.....	8
3. TEST CONDITIONS.....	9
3.1. EQUIPMENT USED DURING TEST	9
3.2. INPUT/OUTPUT PORTS	9
3.3. POWER INTERFACE	9
3.4. OPERATING FREQUENCIES	10
3.5. OPERATION MODES	10
3.6. ENVIRONMENT CONDITIONS.....	10
3.7. TEST CONFIGURATIONS	11
3.8. LIST OF TEST EQUIPMENT.....	12
4. OVERVIEW OF TECHNICAL REQUIREMENTS	13
5. TEST RESULTS.....	14
5.1. 6 dB BANDWIDTH & OCCUPIED BANDWIDTH.....	14
5.2. MAXIMUM PEAK OUTPUT POWER	19
5.3. POWER SPECTRAL DENSITY.....	21
5.4. CONDUCTED SPURIOUS EMISSION MEASUREMENT.....	25
5.5. RADIATED SPURIOUS EMISSIONS MEASUREMENT	30
5.6. ANTENNA REQUIREMENT	38
APPENDIX A. ACCREDITATIONS AND AUTHORIZATIONS	39
APPENDIX B - MEASUREMENT UNCERTAINTIES	39

1. General Product Information

1.1. Equipment Description

OELD is a Smart Junction Box for Gas Detectors with Bluetooth LE.

1.2. Details of Test Equipment (EUT)

- Equipment Type : Smart Junction Box for Gas Detectors
- Model No. : OELD
- Type of test Equipment : Fixed type
- Operating characteristic : Short range wireless device operating in the 2400 – 2483.5 ISM frequency band
- Manufacturer : Honeywell Analytics Asia Pacific Co., Ltd.
7F SangAm IT Tower, 434 Worldcup Buk-ro, Mapo-gu, Seoul 03922, South Korea

1.3. Equipment Configuration

The EUT is consisted of the following component provided by the manufacturer.

Use*	Product Type	Manufacturer	Model	Comments
EUT	Smart Junction Box for Gas Detectors	Honeywell Analytics Asia Pacific Co., Ltd.	OELD	-
Note: Use = EUT - Equipment Under Test, AE - Auxiliary/Associated Equipment. SIM - Simulator (Not Subjected to Test)				

1.4. Technical Data

Item	Description
Frequency Ranges	2 402 – 2 480 MHz
Output power	Max. 3 dBm
Kind of modulation (s)	GFSK
Channel	40 channels (Bluetooth LE)
Antenna Gain	Max. -1.50 dBi
Working temperature	-40 ~ 65 °C
Supply Voltage	DC 24.0 V

Note ;

1. All the technical data described above were provided by the manufacturer.

1.5. Antenna Information

Antenna Type : PCB Pattern antenna
Manufacturer : RAE Systems by Honeywell
Transmit Gain dBi : Max. -1.50 dBi

1.6. Equipment Type :

- Radio and ancillary equipment for fixed or semi-fixed use
- Radio and ancillary equipment for vehicular mounted use
- Radio and ancillary equipment for portable or handheld use

- Stand alone Host connected
- Self contained single unit Module with associated connection or interface

1.7. Technical descriptions and documents

The following documents was provided by the manufacturer.

No.	Document Title and Description
1	User Manual

1.8. Equipment Marking Plate

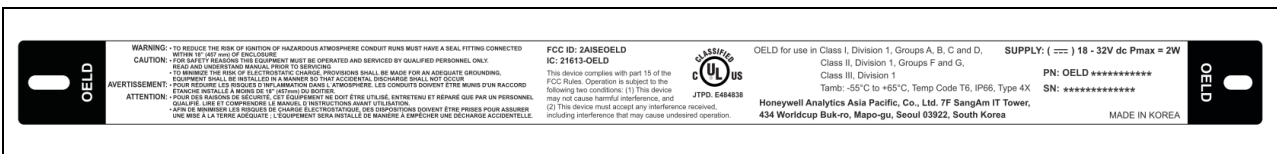

1.9. Description of additional model name

Model name	Model name Designation	Description of design
OELD	Basic model	-
OELD B <u>XXXXX</u> A DNU <u>X</u>	-	XXXXX : Gas Detector Description A : OELD Enclosure Material (A: Aluminum / S: Stainless) X: Reserved

1.10. Duty Cycle

Modulation Type	Data Rate	On Time (ms)	Period (ms)	Duty Cycle X (linear)	Duty Cycle (%)	Duty Cycle Correction Factor (dB)	1/T Minimum VBW (kBW)
GFSK	1 Mbps	0.38732	0.62568	0.6190	61.90	2.08	1.598

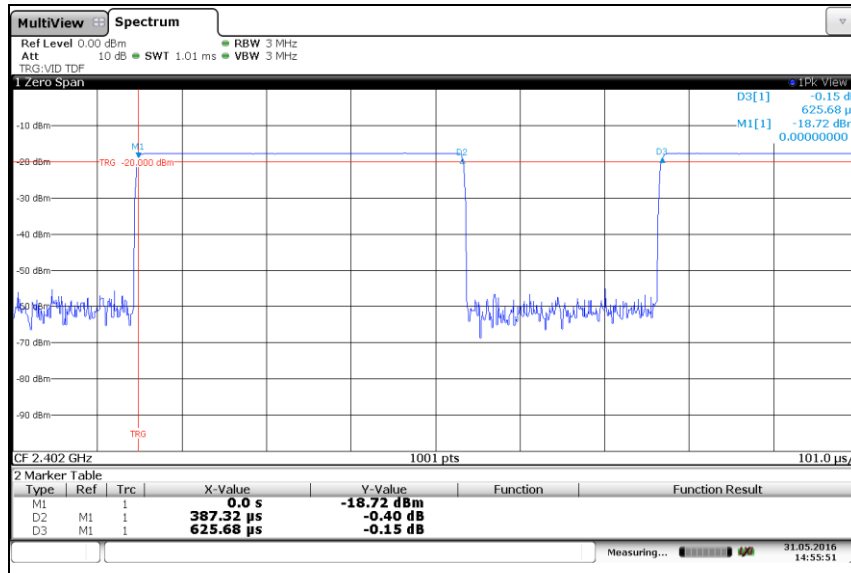

2. Test Specification

The following test specifications and standards have been applied and used for testing.

- 1) FCC Part 15 C Section 15.247 : Operation within the bands 902–928 MHz, 2400–2483.5 MHz, and 5725–5850 MHz
- 2) IC RSS-247 : Digital Transmission Systems (DTSs), Frequency Hopping Systems (FHSs) and Licence-Exempt Local Area Network (LE-LAN) Devices
- 3) IC RSS-GEN : General Requirements for Compliance of Radio Apparatus
- 4) ANSI C63.10:2013 : American National Standard for Testing Unlicensed Wireless Devices
- 5) KDB 558074 v03r05 : Guidance for Performing Compliance Measurements on Digital Transmission Systems (DTS) Operating Under §15.247

3. Test Conditions

3.1. Equipment Used During Test

Use*	Product Type	Manufacturer	Model	Comments
EUT	Smart Junction Box for Gas Detectors s	Honeywell Analytics Asia Pacific Co., Ltd.	OELD	-
AE	Note PC	Lenovo Group Led.	80QQ	-

Note: Use = EUT - Equipment Under Test, AE - Auxiliary/Associated Equipment. SIM - Simulator (Not Subjected to Test)

3.2. Input/Output Ports

No	Port Name	Type*	Cable Max. >3m (Y/N)	Cable Shielded (Y/N)	Comments
1	Power Input	DC	N	N	Connected to DC Power supply
2	Radio Antenna	I/O	N	Y	-
3	USB port	I/O	N	Y	Connected to Note PC

Note:
 *AC = AC Power Port DC = DC Power Port N/E = Non-Electrical
 I/O = Signal Input or Output Port (Not Involved in Process Control)
 TP = Telecommunication Ports

3.3. Power Interface

Mode #	Voltage (V)	Current (A)	Power (W)	Frequency (DC/AC-Hz)	Phases (#)	Comments
Rated	24.0V	-	-	DC	-	Rating of EUT

3.4. Operating Frequencies

Mode #	Frequency tested
1	Operating frequency range : 2 402 MHz ~ 2 480 MHz (Bluetooth LE) - Low : 2 402 MHz - Mid : 2 440 MHz - High : 2 480 MHz

3.5. Operation Modes

Mode #	Description
1	Carrier on mode: Signal from the RF module was generated continuously for the representative channels (Low, Mid, High) by the test program incorporated

3.6. Environment Conditions

Parameters	Normal condition
Temperature	-45°C to +65°C
Humidity	20 % to 75 %
Supply voltage	DC 24.0 V (Rated nominal voltage)

Note ;

- The operating condition for humidity requirement has not been declared in the manufacturer's specification.
- Test has been carried out for three frequencies specified above under the normal condition.

3.7. Test Configurations

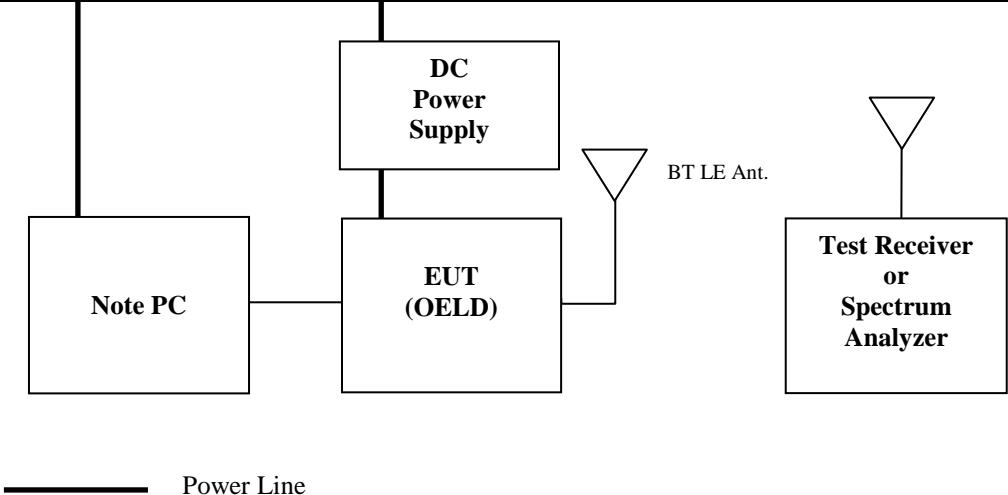
Mode #	Description
1	 <p style="text-align: center;"> Power Line </p>
<p>Note ;</p> <ul style="list-style-type: none"> - Antenna-port conducted tests can't be performed on an EUT. - All tests are conducted by radiated compliance measurements. 	

3.8. List of Test Equipment

No	Description	Manufacturer	Model	Identifier	Cal. Due
1	Signal & Spectrum Analyzer	R&S	FSW 43	100578	17.05.04
2	DC Power Supply	TAKASAGO	EX-1500H2	1211499111	17.01.21
3	Signal Generator	R&S	SMF100A	101441	17.01.24
4	Test Receiver	R&S	ESU 26	100303	17.01.20
5	Trilog Broadband Antenna	Schwarzbeck	VULB9163	9163 770	17.02.08
6	Pre-Amplifier	SONOMA INSTRUMENT	310N	344015	17.01.20
7	Pre-Amplifier	R&S	SCU 18D	19006450	17.01.20
8	Low Noise Amplifier	MITEQ	AMF-6F-18004000-37- 8F	1814914	17.10.14
9	Horn Antenna	R&S	HF 907	102426	17.01.15
10	Horn Antenna	Schwazbeck	BBHA9170	BBHA9170440	17.09.06
11	Loop Antenna	R&S	HFH2-Z2	100147	17.08.09
12	Antenna Mast	INNCO SYSTEM	MA4000-EP	4600814	-
13	Turn Table	INNCO SYSTEM	DT3000-3T	1310814	-
14	Camera Controller	PONTIS	HDCon4102	6531445048	-
15	CO3000 Controller	INNCO SYSTEM	Co3000-4Port	CO3000/806/ 34130814/L	-
16	Attenuator	R&S	6 dB	272.4110.50	17.01.20

4. Overview of Technical requirements

The following essential requirements and test specifications are relevant to the presumption of conformity FCC Part 15 C Section 15.247 and RSS-247, RSS-GEN				Reported
FCC Reference Clause No.	IC Reference Clause No.	Essential technical requirements	Test method	
15.247(a)(2)	RSS-247 5.2(1)	6 dB Bandwidth Occupied Bandwidth	KDB 558074	[X]
15.247(b)(3)	RSS-247 5.4(4)	Maximum peak output power	KDB 558074	[X]
15.247(e)	RSS-247 5.2(2)	Power spectral density	KDB 558074	[X]
15.247(d)	RSS-247 5.5	Band Edge Conducted spurious emission	KDB 558074	[X]
15.205(a) 15.209(a)	RSS-247 5.5 RSS-GEN 8.9	Radiated spurious emissions	ANSI C63.10 KDB 558074	[X]

5. Test Results

5.1. 6 dB Bandwidth & Occupied Bandwidth

TEST: 6 dB Bandwidth & Occupied Bandwidth		
Method	a) Set RBW = 100 kHz. b) Set the video bandwidth (VBW) $\geq 3 \times$ RBW. c) Detector = Peak. d) Trace mode = max hold. e) Sweep = auto couple. f) Allow the trace to stabilize. g) Measure the maximum width of the emission that is constrained by the frequencies associated with the two outermost amplitude points (upper and lower frequencies) that are attenuated by 6 dB relative to the maximum level measured in the fundamental emission.	
Reference Clause	Part15 C Section 15.247 (a)(2) RSS-247 5.2(1), RSS-GEN 6.6	
Parameters recorded during the test	Laboratory Ambient Temperature	22.2 °C
	Relative Humidity	50.1 %
	Frequency range	Measurement Point
Fully configured sample scanned over the following frequency range	2 402 MHz - 2 480 MHz	Enclosure

Configuration Settings

Power Interface Mode # (See Section 3.3)	EUT Operation Mode # (See Section 3.5)	Test Configurations Mode # (See Section 3.7)
Rated	1	1
Supplementary information: None		

Limits

According to §15.247(a)(2), systems using digital modulation techniques may operate in the 902 ~928 MHz, 2400 ~ 2483.5 MHz, and 5725 ~ 5825 MHz bands. The minimum of 6 dB Bandwidth shall be at least 500 kHz.

5.1.1. Measurement Results

Table 1. Data Table of 6 dB Bandwidth

Operating Mode	Data Rate (Mbps)	Channel	Channel Frequency (MHz)	6 dB Bandwidth (MHz)	Limit (MHz)
GFSK	1	Low	2 402	0.755	0.5
		Middle	2 440	0.758	
		High	2 480	0.779	

Table 2. Data Table of Occupied Bandwidth (99% Bandwidth)

Operating Mode	Data Rate (Mbps)	Channel	Channel Frequency (MHz)	99% Bandwidth (MHz)	Limit (MHz)
GFSK	1	Low	2 402	1.120	-
		Middle	2 440	1.106	
		High	2 480	1.096	

Figure 1. Plots of 6 dB Bandwidth

GFSK : Low

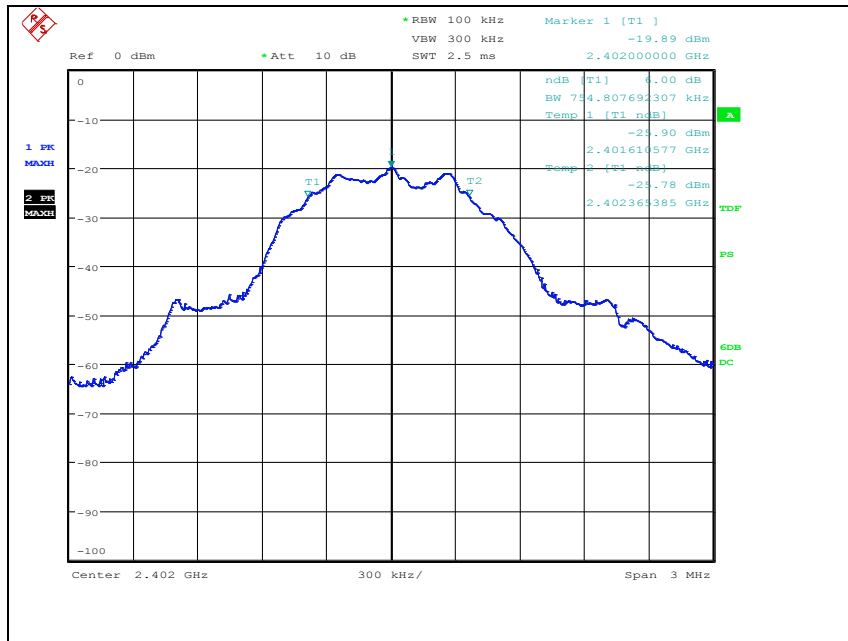

GFSK : Middle

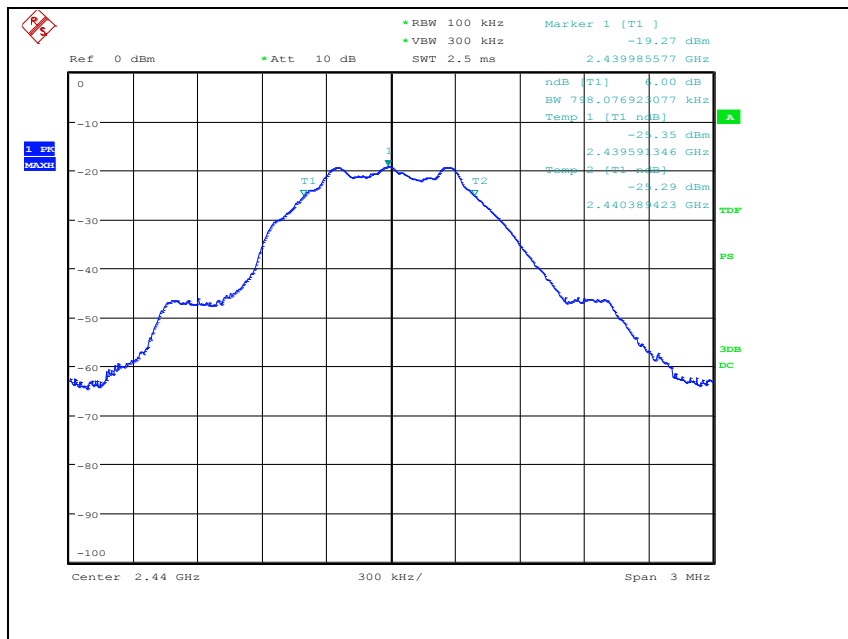

GFSK : High

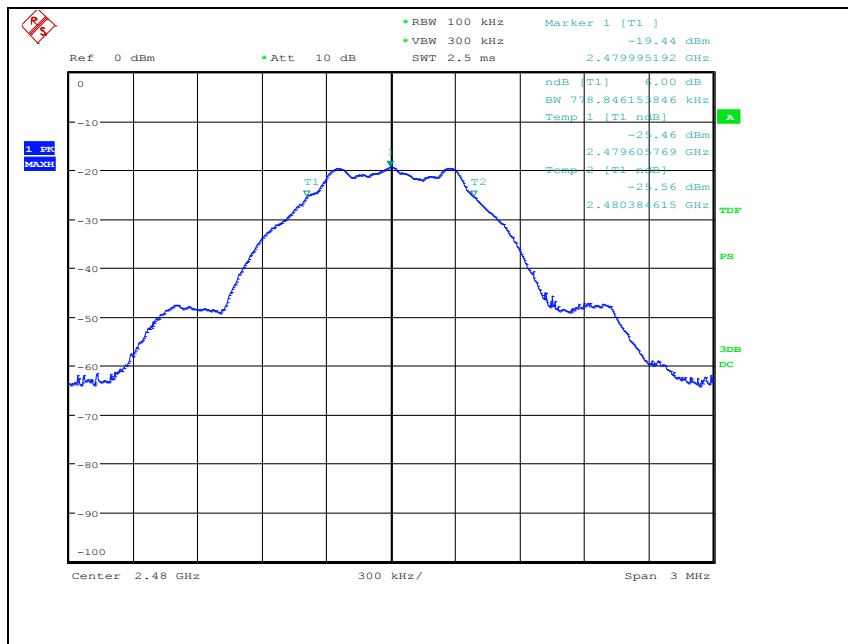
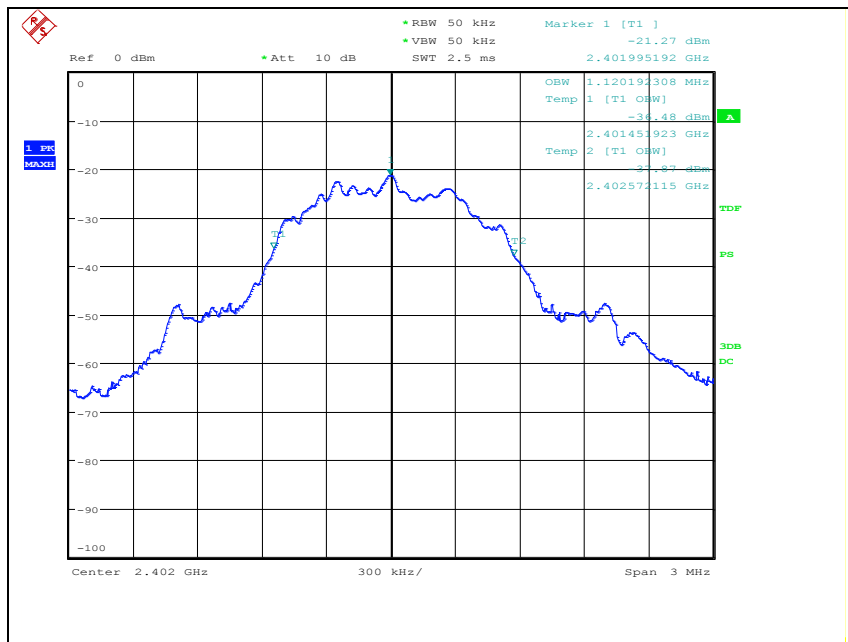
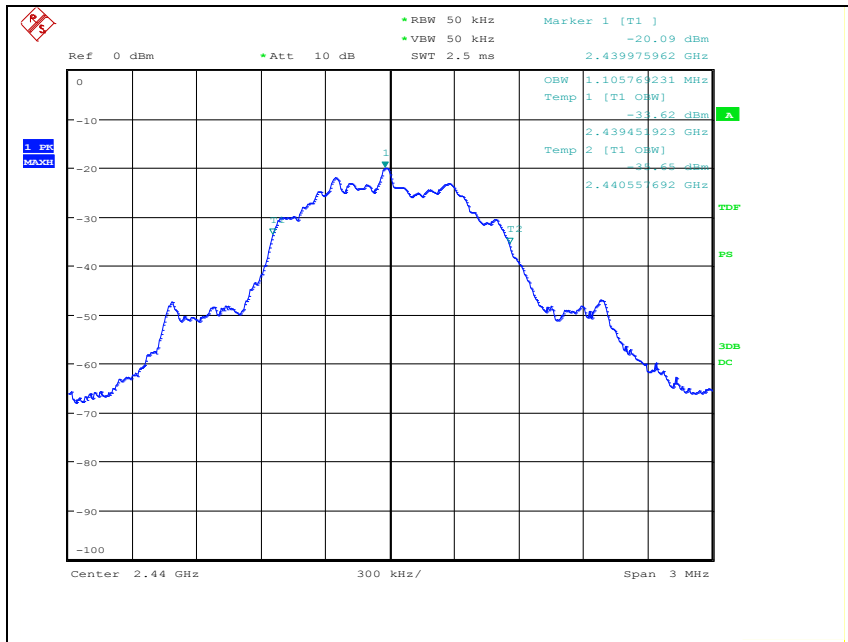

Figure 2. Plots of 99% Bandwidth

GFSK : Low



GFSK : Middle



GFSK : High

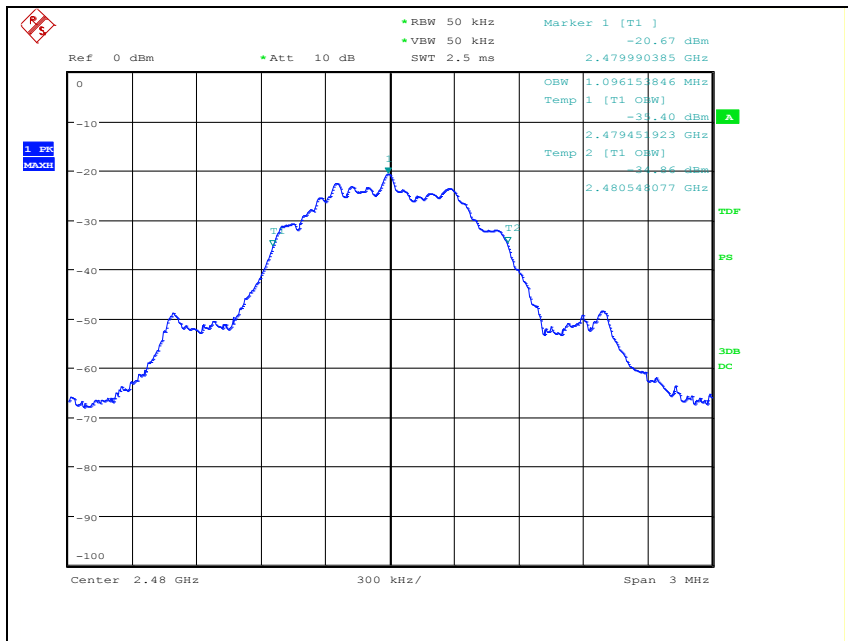

5.2. Maximum Peak Output Power

TEST: Maximum Peak Output Power		
Method	The field strength levels shall be converted to equivalent conducted power levels for comparison to the applicable output power limit. This is accomplished by first measuring the radiated field strength. The radiated field strength is converted to EIRP.(refer to ANSI C63.10 for guidance).	
Reference Clause	Part15 C Section 15.247 (b)(3) RSS-247 5.4(4)	
Parameters recorded during the test	Laboratory Ambient Temperature	22.2 °C
	Relative Humidity	50.1 %
	Frequency range	Measurement Point
Fully configured sample scanned over the following frequency range	2 402 MHz - 2 480 MHz	Enclosure

Configuration Settings

Power Interface Mode # (See Section 3.3)	EUT Operation Mode # (See Section 3.5)	Test Configurations Mode # (See Section 3.7)
Rated	1	1
Supplementary information: None		

Limits

According to §15.247(b)(3), for systems using digital modulation in the 902 ~ 928 MHz, 2400 ~2483.5 MHz, and 5725 ~ 5850 MHz band: 1 Watt. As an alternative to a peak power measurement, compliance with the one watt limit can be based on a measurement of the maximum conducted output power. Maximum Conducted output Power is defined as the total transmit power delivered to all antennas and antenna elements averaged across all symbols in the signaling alphabet when the transmitter is operating at its maximum power control level. Power must be summed across all antenna elements. The average must not include any intervals during which the transmitter is off or is transmitting at a reduced power level. If multiple modes of operation are possible (e.g., alternative modulation methods), the maximum conducted output power is the highest total transmit power occurring in any mode.

According to §15.247(b)(4), the conducted output power limit specified in paragraph(b) of this section is based on the use of antenna with directional gains that do not exceed 6 dBi. Except as shown in paragraph(c) of this section, if transmitting antenna of directional gain greater than 6 dBi are used, the conducted output power from the intentional radiator shall be reduced below the stated values in paragraph (b)(1), (b)(2), and (b)(3) of this section, as appropriate, by the amount in dB that the directional gain of the antenna exceeds 6 dBi.

Measurement Results

Table 3. Data Table of Maximum Peak Output Power

Operating Mode	Data Rate (Mbps)	Channel	Channel Frequency (MHz)	E (dBuV/m)	EIRP (dBm)	Output Power (dBm)	Limit (dBm)
GFSK	1	Low	2 402	76.64	-18.62	-17.12	30
		Middle	2 440	76.94	-18.32	-16.82	
		High	2 480	76.71	-18.55	-17.05	

Supplementary information:

- The measurement distance(D) is 3m.
- $EIRP (dBm) = E (dBuV/m) + 20 \log(D) - 104.8$
- $Output Power (dBm) = EIRP - Antenna gain (-1.5 dBm)$

5.3. Power Spectral Density

TEST: Power Spectral Density		
Method	1. The factor is calculated as follows - Factor(dB) = 20 log(d[m]) – 104.8 – EUT Antenna gain, where d is distance at which the field strength limit is specified in the applicable requirements. 2. The factor apply to receiver and then measure the radiated power levels using a methodology from peak power spectral density as applicable. a) Set analyzer center frequency to DTS channel center frequency. b) Set the span to 1.5 times the <i>DTS bandwidth</i> . c) Set the RBW to: 3 kHz ≤ RBW ≤ 100 kHz. d) Set the VBW ≥ 3 × RBW. e) Detector = peak. f) Sweep time = auto couple. g) Trace mode = max hold. h) Allow trace to fully stabilize. i) Use the peak marker function to determine the maximum amplitude level within the RBW. j) If measured value exceeds limit, reduce RBW (no less than 3 kHz) and repeat.	
Reference Clause	Part15 C Section 15.247 (e) RSS-247 5.2(2)	
Parameters recorded during the test	Laboratory Ambient Temperature	22.2 °C
	Relative Humidity	50.1 %
	Frequency range	Measurement Point
Fully configured sample scanned over the following frequency range	2 402 MHz - 2 480 MHz	Enclosure

Configuration Settings

Power Interface Mode # (See Section 3.3)	EUT Operation Mode # (See Section 3.5)	Test Configurations Mode # (See Section 3.7)
Rated	1	1
Supplementary information: None		

Limits

§15.247(e) For digitally modulated system, the power spectral density conducted from the intentional radiator to the antenna shall not be greater than 8 dB m in any 3 kHz band any time interval of continuous transmission. This power spectral density shall be determined in accordance with the provisions of paragraph (b) of this section. The same method of determining the conducted output power shall be used to determine the power spectral density.

Measurement Result

Table 4. Data Table of Power Spectral Density

Operating Mode	Data Rate (Mbps)	Channel	Channel Frequency (MHz)	PSD Result (dBm)	Limit (dBm)
GFSK	1	Low	2 402	-19.72	8
		Middle	2 440	-19.28	
		High	2 480	-19.45	

Supplementary information:

- The measurement distance(D) is 3m.
- Factor(dB) = $20 \log(D) - 104.8 + 1.5 (\text{Antenna gain}) = -93.76$

Figure 3. Plots of Power Spectral Density

GFSK : Low

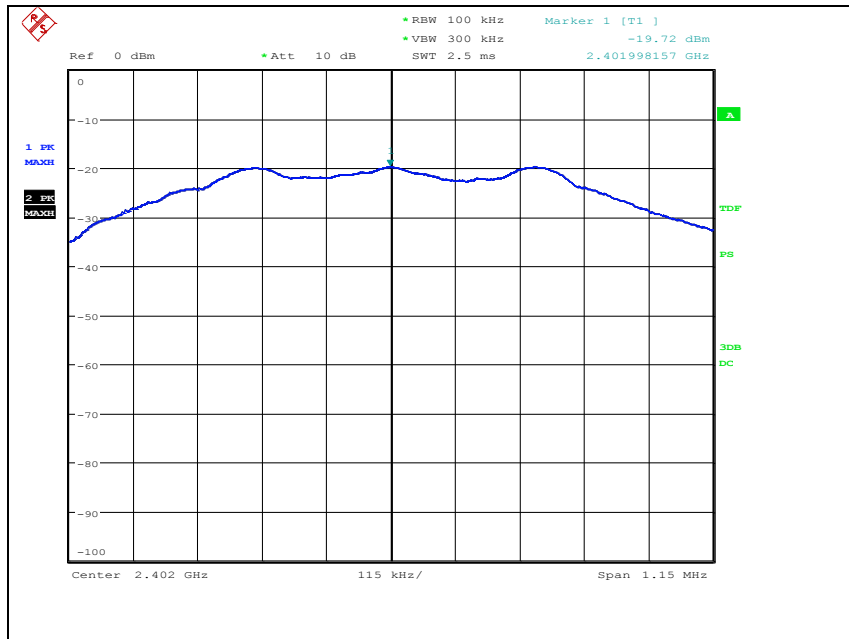

GFSK : Middle

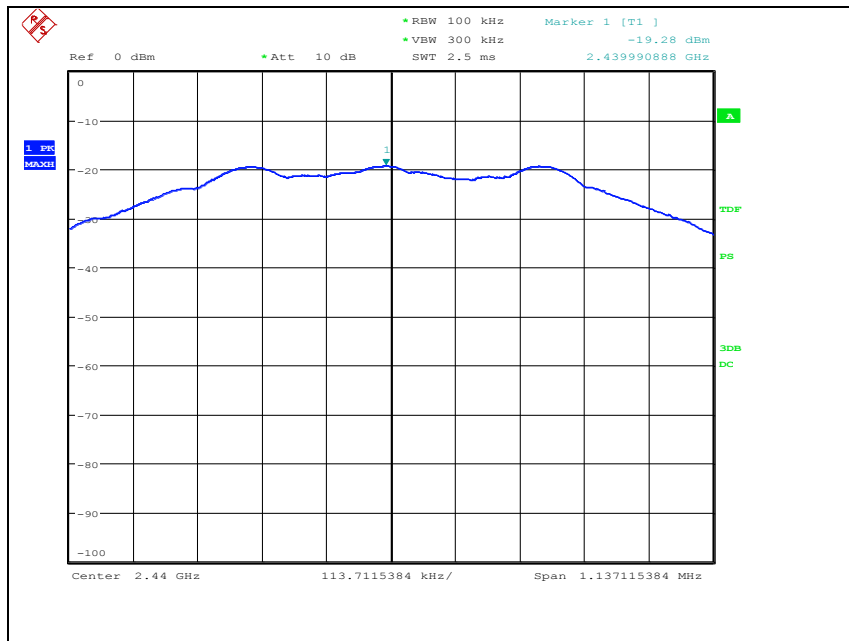

GFSK : High

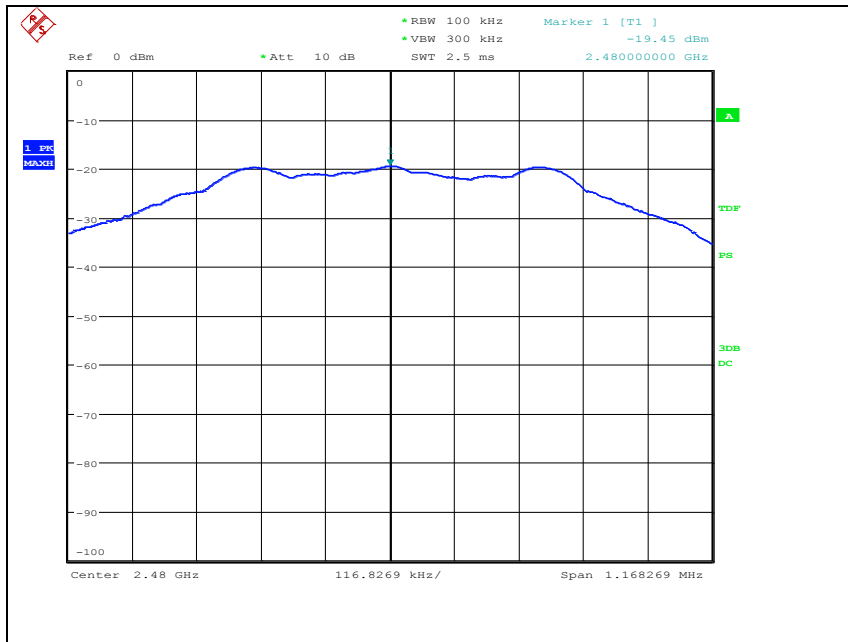

5.4. Conducted spurious emission Measurement

TEST: Conducted spurious emission measurement		
Method	a) Set the center frequency and span to encompass frequency range to be measured. b) Set the RBW = 100 kHz. c) Set the VBW $\geq 3 \times$ RBW. d) Detector = peak. e) Sweep time = auto couple. f) Trace mode = max hold. g) Allow trace to fully stabilize. h) Use the peak marker function to determine the maximum amplitude level.	
Reference Clause	Part15 C Section 15.247 (d) RSS-247 5.5 RSS-GEN 8.10	
Parameters recorded during the test	Laboratory Ambient Temperature	22.2 °C
	Relative Humidity	50.1 %
	Frequency range	Measurement Point
Fully configured sample scanned over the following frequency range	30 MHz – 25 GHz	Enclosure

Configuration Settings

Power Interface Mode # (See Section 3.3)	EUT Operation Mode # (See Section 3.5)	Test Configurations Mode # (See Section 3.7)
Rated	1	1
Supplementary information: None		

Limits

According to §15.247(d), in any 100 kHz bandwidth outside the frequency band in which the spread spectrum or digitally modulated intentional radiator is operating, the radio frequency power that is produced by the intentional radiator shall be at least 20 dB below that in the 100 kHz bandwidth within the band that contains the highest level of the desired power, based on either an RF conducted or a radiated measurement, provided the transmitter demonstrates compliance with the peak conducted power limits. Attenuation below the general limits specified in section §15.209(a) is not required. In addition, radiated emission which in the restricted band, as define in section §15.205(a), must also comply the radiated emission limits specified in section §15.209(a) (see section §15.205(c))

Measurement Results

Figure 4. Plots of Band-Edge and Restricted / Non-Restricted frequency bands

GFSK : Low

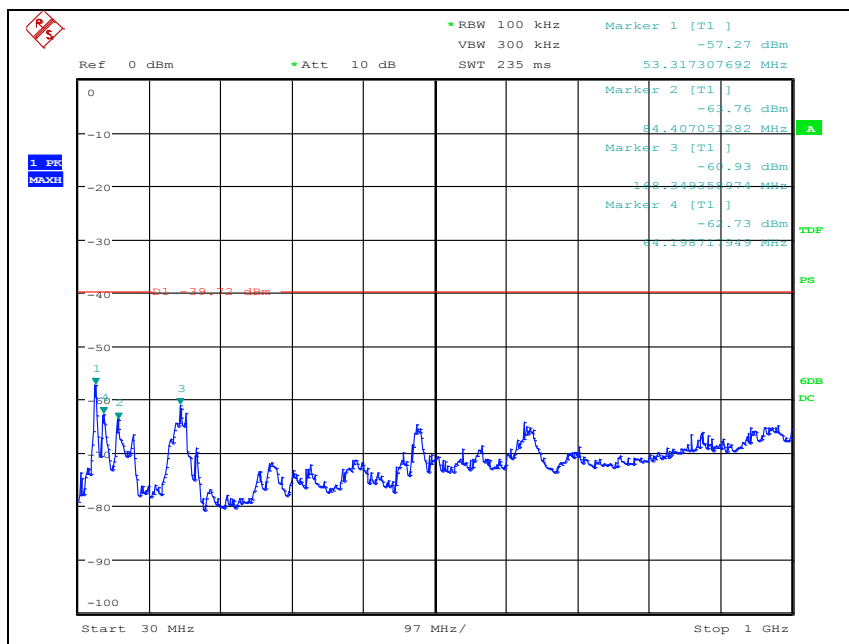
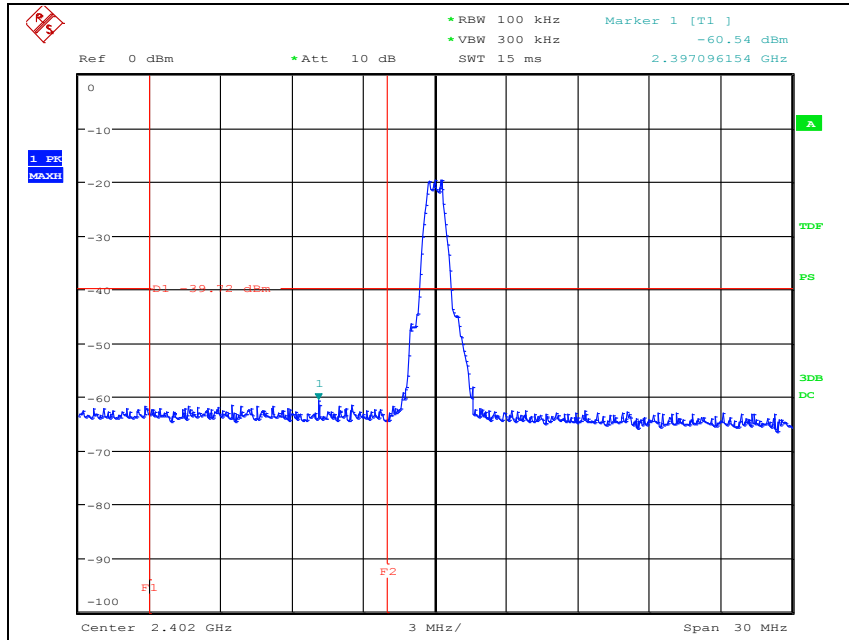

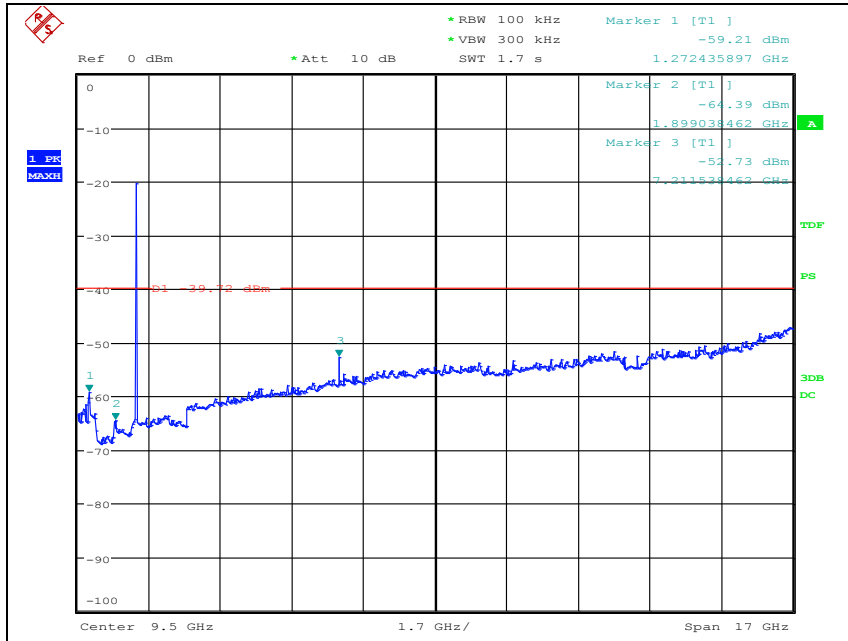

GFSK : Middle

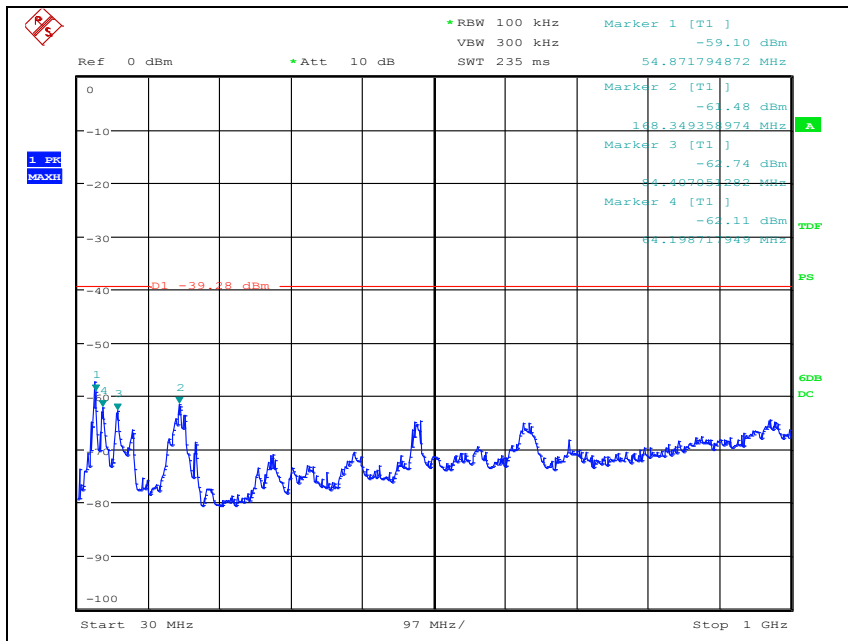

5.5. Radiated Spurious Emissions Measurement

TEST: Radiated spurious emissions measurement		
Method	Radiated emissions from the EUT were measured according to ANSI C63.10 procedure. 1. The EUT was placed on the top of a rotating table 0.8 meters and 1.5 meters above the ground at a 3 meter anechoic chamber test site. The table was rotated 360 degrees to determine the position of the highest radiation. The antenna is varied from 1 to 4 meters above the ground to find the maximum field strength. Measurement are made with both horizontal and vertical polarizations For fundamental investigation, the EUT was positioned for 3 orthogonal orientations. 2. For measurement below 1GHz, the resolution bandwidth is set to 100 kHz for peak detection or 120kHz for quasi-peak detection measurements. Peak detection is used unless otherwise noted as quasi-peak. 3. For measurements above 1 GHz the resolution bandwidth is set to 1 MHz, then the video bandwidth is set to 1 MHz for peak measurements and add duty cycle factor for average measurements. 4. For 2.4GHz transmitter measurement, the spectrum from 30 MHz to 26GHz is investigated for Low, Mid and High channels. 5. For 5 GHz transmitter measurement, the spectrum from 30 MHz to 40GHz is investigated for Low, Mid and High channels.	
Reference Clause	Part15 C Section 15.205 (a), 15.209(a) RSS-247 5.5/ RSS-GEN 8.9, 8.10	
Parameters recorded during the test	Laboratory Ambient Temperature	22.2 °C
	Relative Humidity	50.1 %
	Frequency range	Measurement Point
Fully configured sample scanned over the following frequency range	30 MHz – 25 GHz	Enclosure

Configuration Settings

Power Interface Mode # (See Section 3.3)	EUT Operation Mode # (See Section 3.5)	Test Configurations Mode # (See Section 3.7)
Rated	1	1
Supplementary information: None		

Limits

According to §15.247(d), in any 100 kHz bandwidth outside the frequency band in which the spread spectrum or digitally modulated intentional radiator is operating, the radio frequency power that is produced by the intentional radiator shall be at least 20 dB below that in the 100 kHz bandwidth within the band that contains the highest level of the desired power, based on either an RF conducted or a radiated measurement, provided the transmitter demonstrates compliance with the peak conducted power limits. In addition, radiated emission which in the restricted band, as define in section §15.205(a), must also comply the radiated emission limits specified in section §15.209(a) (see section §15.205(c))

According to § 15.209(a), the emissions from an intentional radiator shall not exceed the field strength levels specified in the following table:

Frequency (MHz)	Distance (meters)	Field Strength (dBuV/m)	Field Strength (uV/m)
0.009-0.490	300	20log(2400/F(kHz))	2400/F(kHz)
0.490-1.705	30	20log(24000/F(kHz))	24000/F(kHz)
1.705-30.0	30	29.5	30
30-88	3	40.0	100
88-216	3	43.5	150
216-960	3	46.0	200
Above 960	3	54.0	500

5.5.1. Radiated Spurious Emissions Below 1 GHz

Measurement method : Radiated Conducted
 Mode of operation : Continuous Wave
 Power setting : Max. Power condition declared by the manufacturer
 Worst case configuration : GFSK low channel

Table 5. Data Table of Radiated emission Below 1 GHz

Frequency [MHz]	Pol.	Detect Mode	Reading [dB(μV)]	Factor [dB]	Level [dB(μV/m)]	Limit [dB(μV/m)]	Margin [dB]
73.65	H	PK	51.8	-16.9	34.9	40.0	5.1
87.23	V	PK	47.8	-16.4	31.4	40.0	8.6
146.40	V	PK	55.9	-17.2	38.7	43.5	4.8
159.01	V	PK	53.4	-16.7	36.7	43.5	6.8
540.22	V	PK	45.8	-5.6	40.2	46.0	5.8
971.86	V	PK	35.7	1.7	37.4	54.0	16.6

Supplementary information:

- The frequency spectrum from 30 MHz to 1 000 MHz was investigated. Emission levels of 30 dB below than the limit is not reported.
- The worst case is x-axis and reported.
- Factor = AF + CL + AG (AF : Antenna factor, CL : Cable loss, AG: Pre-Amp gain)
- Level = Reading + Factor (Factor = AF + CL + AG)
- Margin = Limit (dBuV/m) - Level (dBuV/m)

Figure 5. Test data for Radiated emission below 1GHz

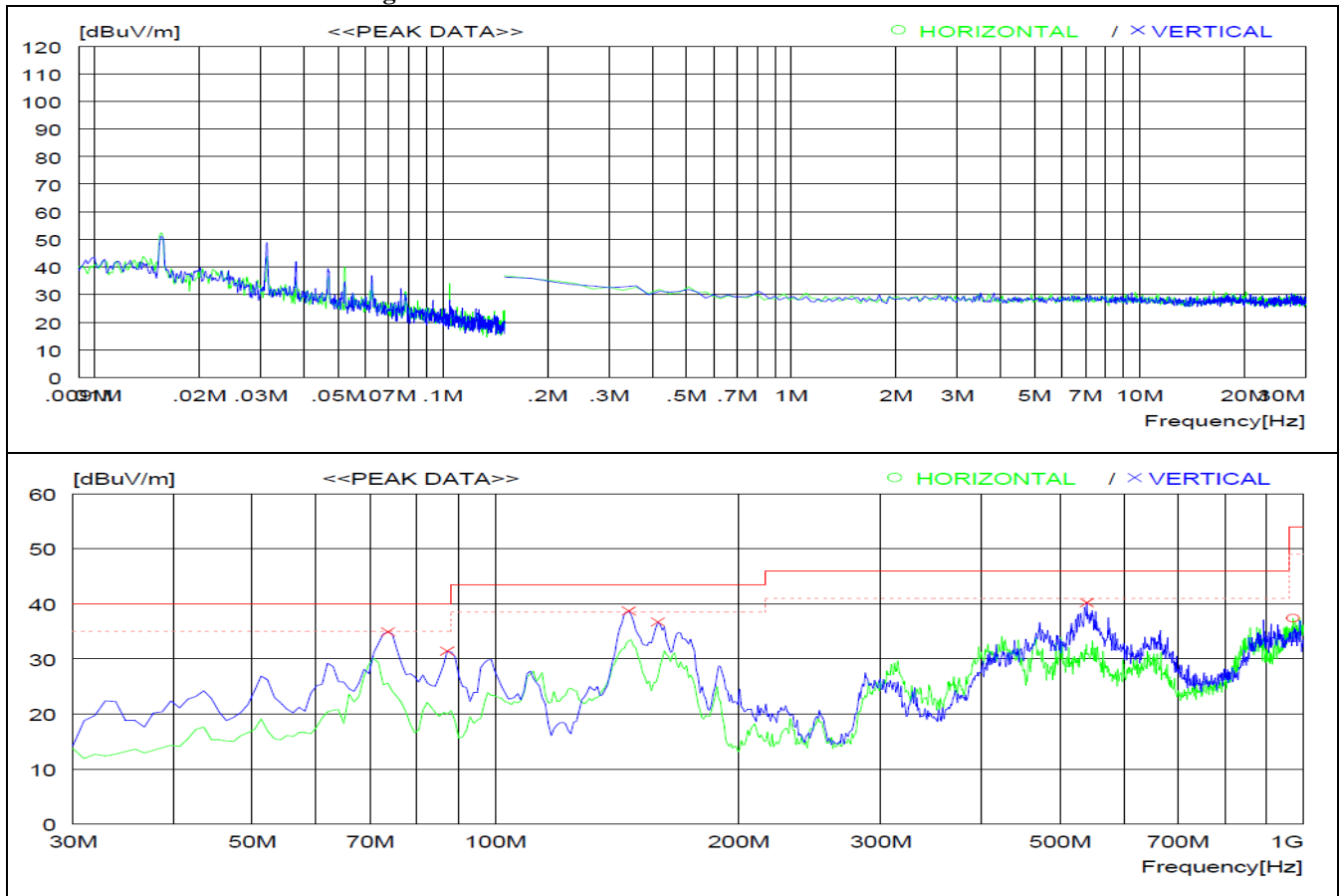

5.5.2. Radiated Spurious Emissions Above 1 GHz

Measurement method : Radiated Conducted
 Mode of operation : Continuous Wave
 Power setting : Max. Power condition declared by the manufacturer

Table 6. Data Table of Radiated emission Above 1 GHz – Low Channel

Frequency [MHz]	Pol.	Detect Mode	Reading [dB(μV)]	Factor [dB]	Level [dB(μV/m)]	Limit [dB(μV/m)]	Margin [dB]
1255.00	H	PK	55.5	-7.5	48.0	74.0	26.0
1255.00	H	AV	29.4	-7.5	21.9	54.0	32.1
1697.00	H	PK	53.7	-5.7	48.0	74.0	26.0
1697.00	H	AV	29.7	-5.7	24.0	54.0	30.0
1918.00	V	PK	52.4	-4.3	48.1	74.0	25.9
1918.00	V	AV	30.1	-4.3	25.8	54.0	28.2
2190.00	V	PK	50.3	-3.8	46.5	74.0	27.5
2190.00	V	AV	29.4	-3.8	25.6	54.0	28.4
4791.00	V	PK	41.0	3.1	44.1	74.0	29.9
4804.00	V	AV	33.2	3.2	36.4	54.0	17.6
7205.00	H	PK	44.8	7.1	51.9	74.0	22.1
7206.00	H	AV	34.1	7.1	41.2	54.0	12.8

Table 7. Data Table of Radiated emission Above 1 GHz – Middle Channel

Frequency [MHz]	Pol.	Detect Mode	Reading [dB(μV)]	Factor [dB]	Level [dB(μV/m)]	Limit [dB(μV/m)]	Margin [dB]
1102.00	V	PK	54.5	-7.4	47.1	74.0	26.9
1102.00	V	AV	29.4	-7.4	22.0	54.0	32.0
1272.00	H	PK	55.3	-7.4	47.9	74.0	26.1
1272.00	H	AV	30.1	-7.4	22.7	54.0	31.3
1867.00	V	PK	51.8	-4.8	47.0	74.0	27.0
1867.00	V	AV	30.1	-4.8	25.3	54.0	28.7
2190.00	V	PK	50.3	-3.8	46.5	74.0	27.5
2190.00	V	AV	31.1	-3.8	27.3	54.0	26.7
4876.00	H	PK	40.0	3.3	43.3	74.0	30.7
4876.00	H	AV	34.4	3.3	37.7	54.0	16.3
7324.00	H	PK	40.2	7.1	47.3	74.0	26.7
7324.00	H	AV	34.9	7.1	42.0	54.0	12.0

Table 8. Data Table of Radiated emission Above 1 GHz – High Channel

Frequency [MHz]	Pol.	Detect Mode	Reading [dB(μV)]	Factor [dB]	Level [dB(μV/m)]	Limit [dB(μV/m)]	Margin [dB]
1170.00	H	PK	55.9	-7.5	48.4	74.0	25.6
1170.00	H	AV	29.9	-7.5	22.4	54.0	31.6
1697.00	H	PK	52.5	-5.7	46.8	74.0	27.2
1697.00	H	AV	30.1	-5.7	24.4	54.0	29.6
1867.00	V	PK	51.7	-4.8	46.9	74.0	27.1
1867.00	V	AV	31.1	-4.8	26.3	54.0	27.7
2224.00	V	PK	50.4	-3.8	46.6	74.0	27.4
2204.00	V	AV	31.4	-3.8	27.6	54.0	26.4
4961.00	V	PK	39.8	3.5	43.3	74.0	30.7
4960.00	V	AV	33.5	3.5	37.0	54.0	17.0
7443.00	H	PK	40.3	7.3	47.6	74.0	26.4
7440.00	H	AV	34.0	7.3	41.3	54.0	12.7

Supplementary information:

- The frequency spectrum from 1 000 MHz to 25 000 MHz was investigated. Emission levels of 30 dB below than the limit is not reported.
- No other spurious and harmonic emissions were found greater than listed emissions on above table.
- The worst case is x-axis and reported.
- * means restricted band
- Factor = AF + CL + AG (AF : Antenna factor, CL : Cable loss, AG: Pre-Amp gain)
- Level = Reading + Factor (Factor = AF + CL + AG)
- Margin = Limit (dBuV/m) - Level (dBuV/m)

5.5.3. Radiated Spurious Emissions Above 1 GHz

Measurement method : Radiated Conducted
 Mode of operation : Continuous Wave
 Power setting : Max. Power condition declared by the manufacturer

Figure 6. GFSK : Low – Restricted Bands

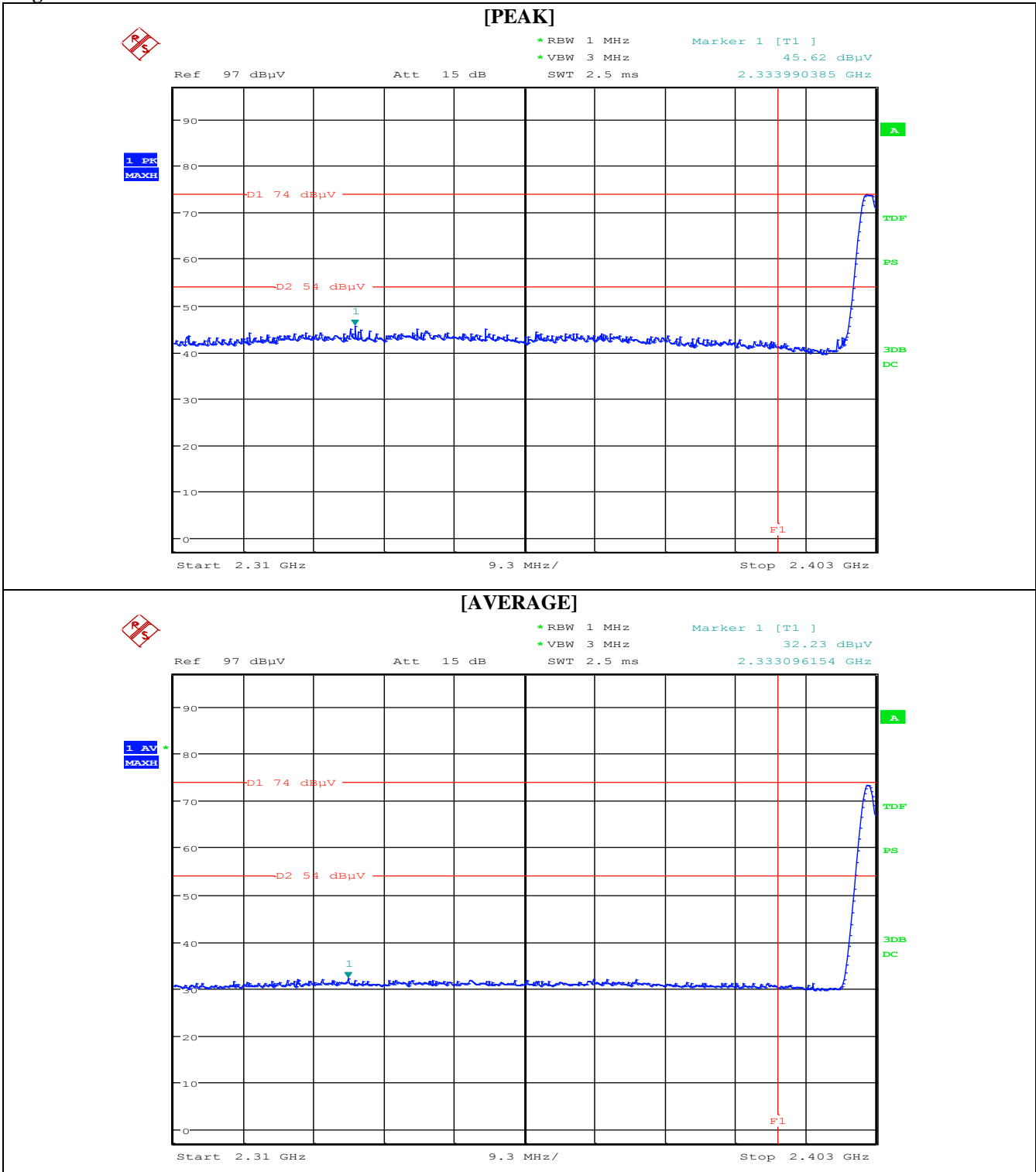

Figure 7. GFSK : High – Restricted Bands

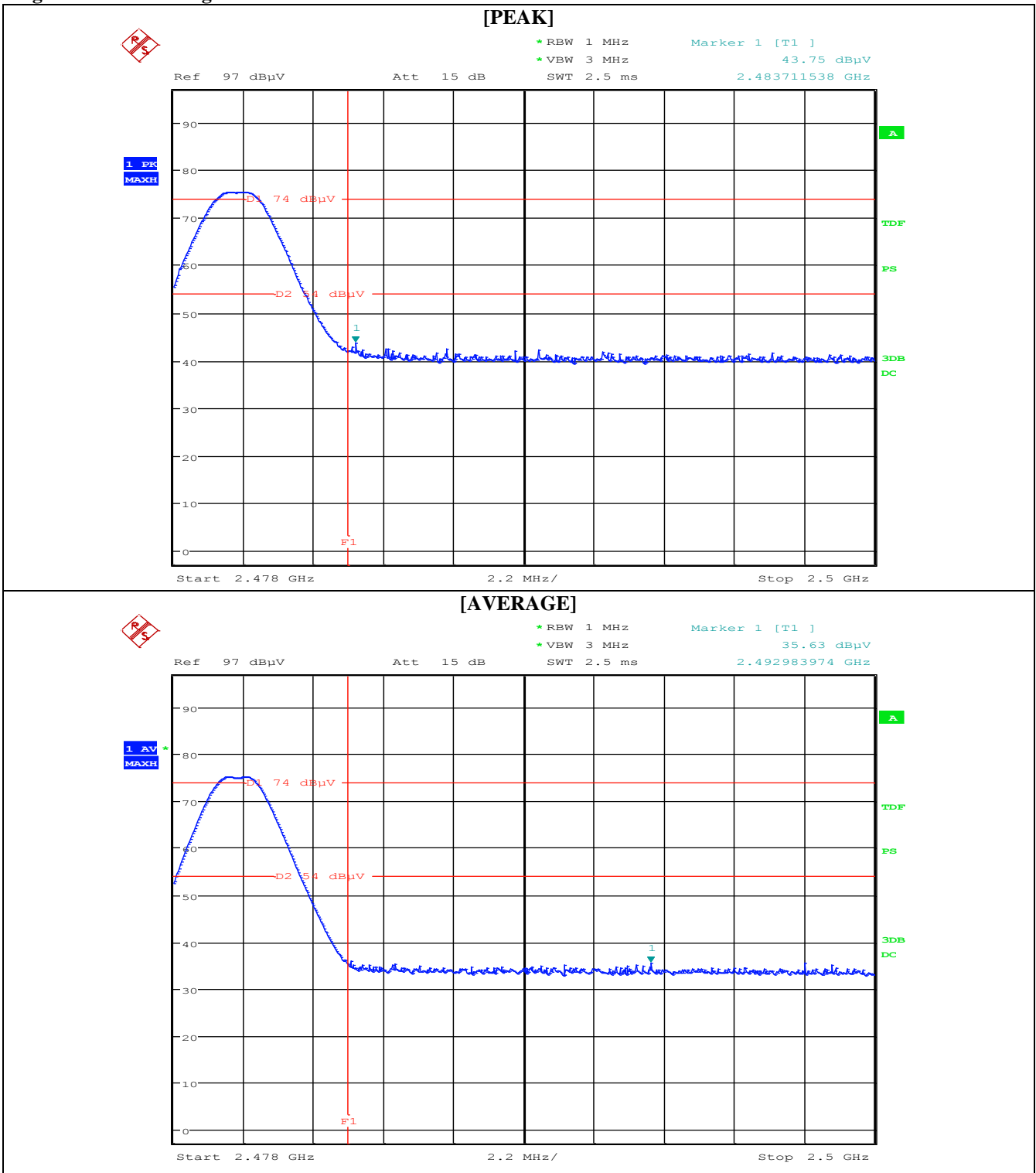

Figure 8. GFSK : Low

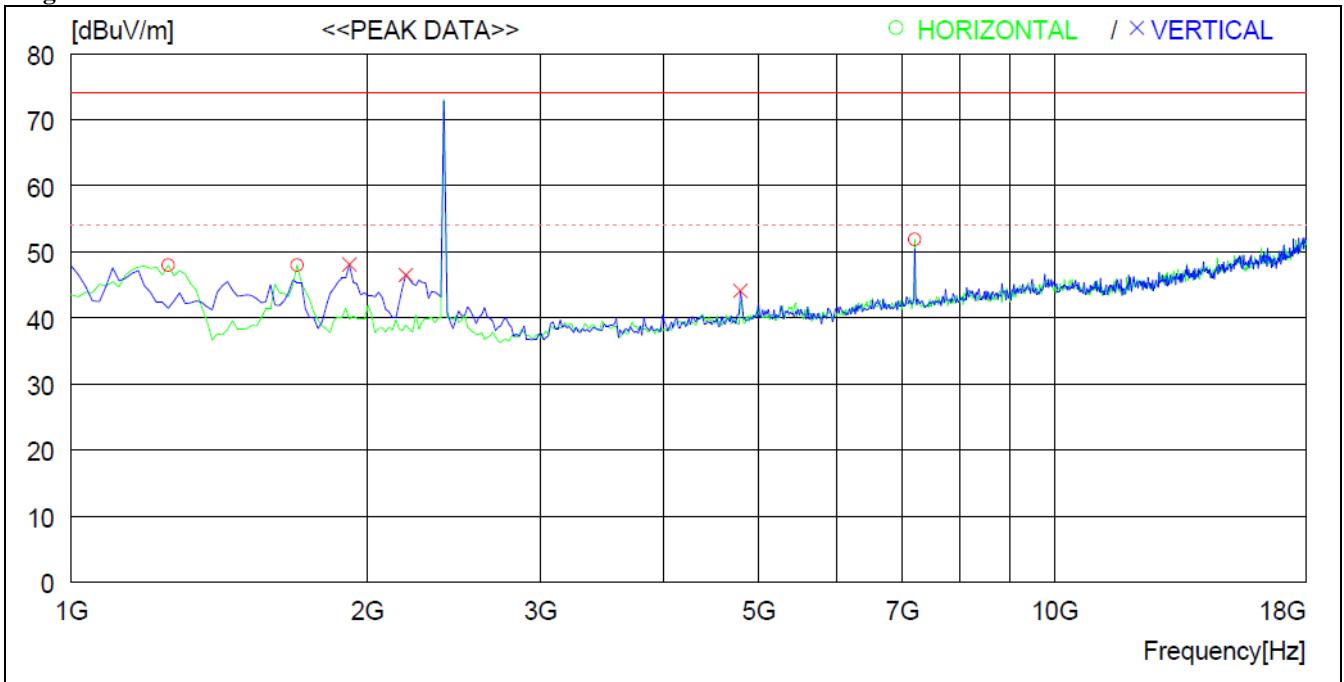
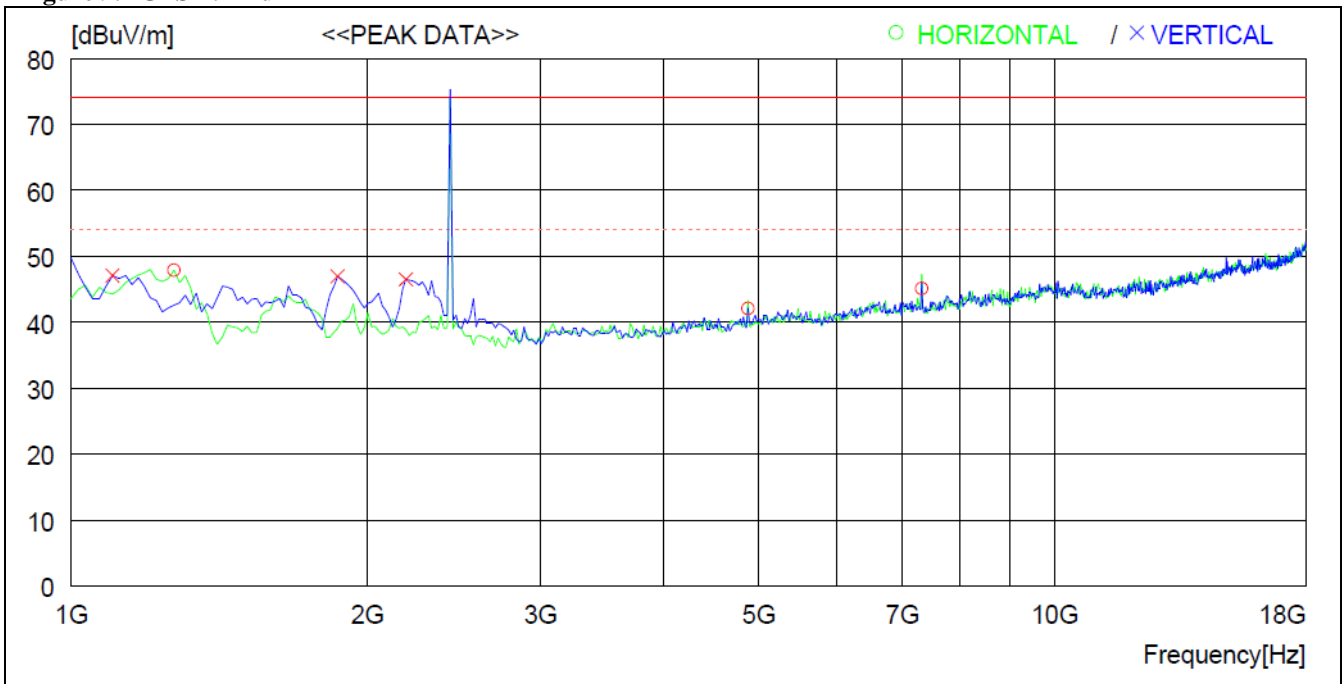
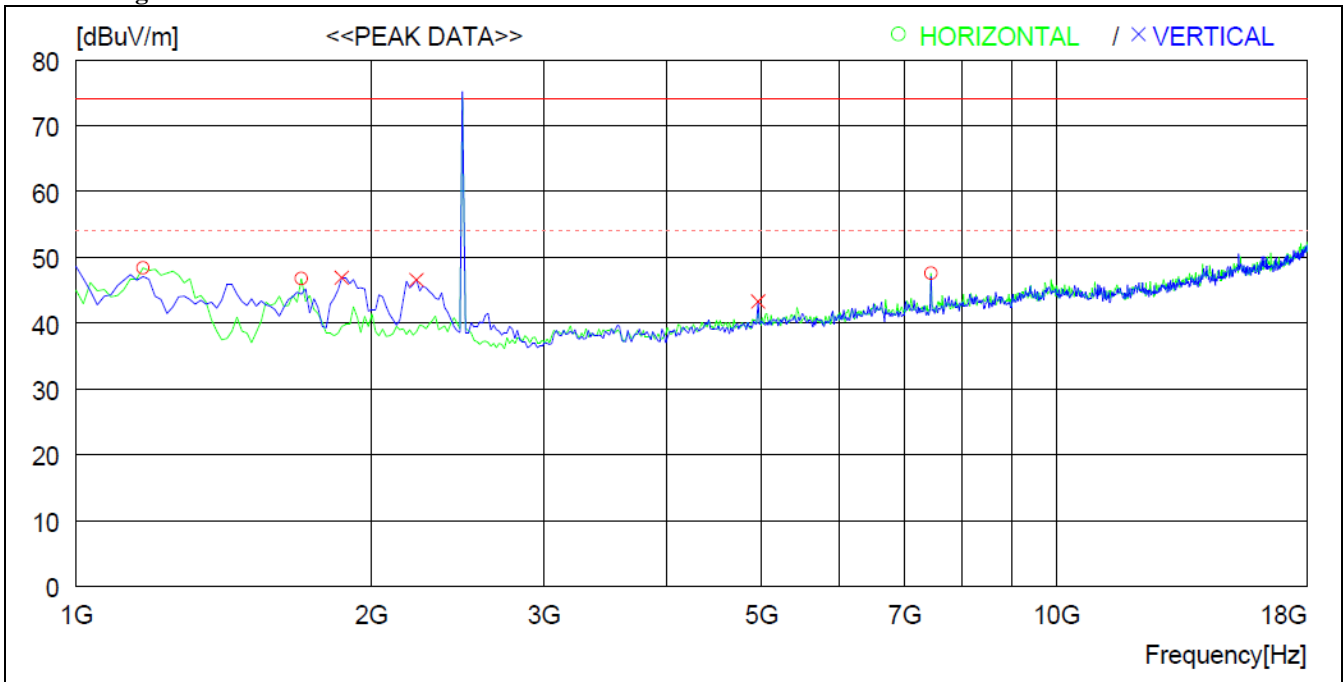

Figure 9. GFSK: Mid



GFSK: High



5.6. Antenna Requirement

5.6.1. Standard Applicable

For intentional device, according to FCC 47 CFR Section §15.203, an intentional radiator shall be designed to ensure that no antenna other than that furnished by the responsible party shall be used with the device. And according to FCC 47 CFR Section § 15.247 (b), if transmitting antennas of directional gain greater than 6 dBi are used, the power shall be reduced by the amount in Db that the gain of the antenna exceeds 6 dBi.

5.6.2. Antenna Connected Construction

The antenna used of this product is Metal Stamping Antenna Assembly and peak max gain of each antennas as below . :

Band	2 402 – 2 480 MHz
Antenna Gain (dBi)	-1.50

APPENDIX A. Accreditations and Authorizations

ENG Inc. has been accredited / filed / authorized by the agencies listed in the following table;

Certificate	Nation	Agency	Code	Mark
Site Filing	USA	FCC	KR0160	Test Facility list & NSA Data
Certification	Korea	KC	KR0160	Test Facility list & NSA Data

Quality control in the testing laboratory is implemented as per ISO/IEC 17025 which is the “General requirements for the competent of calibration and testing laboratory”.

APPENDIX B - MEASUREMENT UNCERTAINTIES

Test Items	Expanded Uncertainty	
Conducted RF Power	± 0.95 dB	
Occupied Bandwidth	± 1.41 kHz	
Conducted Spurious Emissions	30 MHz to 1 000 MHz	± 0.7 dB
	1 GHz to 18 GHz	± 0.8 dB
Radiated Spurious Emissions	0.009 MHz to 30 MHz	± 2.09 dB
	30 MHz to 1 000 MHz	± 4.74 dB
	1 GHz to 18 GHz	± 4.83 dB