

TEST REPORT

Report No.: 24040687HKG-001

HUAJUN TOYS COMPANY LIMITED

Application For Certification
(Original Grant)

FCC ID: 2AIS6-84994

Transmitter - 27MHz RC Controller

Prepared and Checked by:

Approved by:

Signed on File

Leung Chun Ning, Peter
Assistant Engineer

Tang Kwan Mo, Jess
Lead Engineer

Date: May 06, 2024

Intertek's standard Terms and Conditions can be obtained at our website <http://www.intertek.com/terms/>.

The test report only allows to be revised within the retention period unless further standard or the requirement was noticed.

This report is for the exclusive use of Intertek's Client and is provided pursuant to the agreement between Intertek and its Client. Intertek's responsibility and liability are limited to the terms and conditions of the agreement. Intertek assumes no liability to any party, other than to the Client in accordance with the agreement, for any loss, expense or damage occasioned by the use of this report. Only the Client is authorized to permit copying or distribution of this report and then only in its entirety. Any use of the Intertek name or one of its marks for the sale or advertisement of the tested material, product or service must first be approved in writing by Intertek. The observations and test results in this report are relevant only to the sample tested. This report by itself does not imply that the material, product, or service is or has ever been under an Intertek certification program.

© 2017 Intertek

TEST REPORT

GENERAL INFORMATION

Grantee:	HUAJUN TOYS COMPANY LIMITED
Grantee Address:	RM 503-4, 5/F., Tower A, New Mandarin Plaza, 14 Science Museum Rd., Tsim Sha Tsui East, Kowloon, Hong Kong.
Brand Name:	RC FF TUNER RACER
Model:	84994
Additional Model:	84916, 84916A, 83658, 83658A, 82628, 82628A, 82388, 82388A, 85051, 85052, 85053, 85054, 85055, 85056, 85057, 85058, 85059, 85060
Type of EUT:	Transmitter
Description of EUT:	RC FF TUNER RACER
Serial Number:	Not Labelled
FCC ID:	2AIS6-84994
Date of Sample Submitted:	April 12, 2024
Date of Test:	April 22, 2024 to April 24, 2024
Report No.:	24040687HKG-001
Report Date:	May 06, 2024
Environmental Conditions:	Temperature: +10 to 40°C Humidity: 10 to 90%
Conclusion:	Test was conducted by client submitted sample. The submitted sample as received complied with the 47 CFR Part 15 Certification.

TEST REPORT

SUMMARY OF TEST RESULT

Test Specification	Reference	Results
Transmitter Power Line Conducted Emissions	15.207	Not Applicable
Radiated Emission	15.227, 15.209	Complied
Radiated Emission on the Bandedge		
Radiated Emission in Restricted Bands	15.205	Complied

The equipment under test is found to be complying with the following standards:
FCC Part 15, October 1, 2022 Edition

- Note:
1. The EUT uses a permanently attached antenna which, in accordance to section 15.203, is considered sufficient to comply with the pervisions of this section.
 2. Pursuant to FCC part 15 Section 15.215(c), the 20 dB bandwidth of the emission was contained within the frequency band designated (mentioned as above) which the EUT operated. The effects, if any, from frequency sweeping, frequency hopping, other modulation techniques and frequency stability over excepted variations in temperature and supply voltage were considered.

TEST REPORT

TABLE OF CONTENTS

1.0 GENERAL DESCRIPTION..... 5

1.1 Product Description5

1.2 Related Submittal(s) Grants.....5

1.3 Test Methodology5

1.4 Test Facility.....5

2.0 SYSTEM TEST CONFIGURATION..... 6

2.1 Justification6

2.2 EUT Exercising Software.....6

2.3 Special Accessories.....6

2.4 Measurement Uncertainty.....6

2.5 Support Equipment List and Description6

3.0 EMISSION RESULTS..... 7

3.1 Field Strength Calculation7

3.2 Radiated Emission Configuration Photograph.....8

3.3 Radiated Emission Data8

4.0 EQUIPMENT PHOTOGRAPHS..... 10

5.0 PRODUCT LABELLING 10

6.0 TECHNICAL SPECIFICATIONS 10

7.0 INSTRUCTION MANUAL 10

8.0 MISCELLANEOUS INFORMATION 11

8.1 Radiated Emission on the Bandedge11

8.2 Emissions Test Procedures.....12

8.3 Occupied Bandwidth14

9.0 EQUIPMENT LIST 15

TEST REPORT

1.0 GENERAL DESCRIPTION

1.1 Product Description

The Equipment Under Test (EUT), is a portable 27MHz Transmitter for a RC Car. The sample supplied operated on a single channel, 27.145MHz.

The EUT is powered by 2 x 1.5V AA Batteries. After switching on the EUT, the car will be moved forward or backward and turned left and right based on the switches pressed in the controller. Light will be emitted from the car when it is moving forward.

The Models: 84916, 84916A, 83658, 83658A, 82628, 82628A, 82388, 82388A, 85051, 85052, 85053, 85054, 85055, 85056, 85057, 85058, 85059 and 85060 are the same as the Model: 84994 in hardware aspect as declared by client. The models are different in model number, item name, color and packaging only as declared by client.

Antenna Type: External Whip

For electronic filing, the brief circuit description is saved with filename: descri.pdf.

1.2 Related Submittal(s) Grants

This is a single application for certification of a transmitter.

1.3 Test Methodology

Radiated emission measurements were performed according to the procedures in ANSI C63.10 (2013). All radiated measurements were performed in an 3m Chamber. Preliminary scans were performed in the 3m Chamber only to determine worst case modes. All radiated tests were performed at an antenna to EUT distance of 3 meters, unless stated otherwise in the “**Justification Section**” of this Application.

1.4 Test Facility

The 3m Chamber used to collect the radiated data is located at Workshop No. 3, G/F., World-Wide Industrial Centre, 43-47 Shan Mei Street, Fo Tan, Sha Tin, N.T., Hong Kong SAR, China. This test facility and site measurement data have been placed on file with the FCC.

TEST REPORT

2.0 SYSTEM TEST CONFIGURATION

2.1 Justification

The system was configured for testing in a typical fashion (as a customer would normally use it), and in the confines as outlined in ANSI C63.10 (2013).

The device was powered by DC 3.0V (2 x 1.5V AA Batteries).

For maximizing emissions below 30 MHz, the EUT was rotated through 360°, the centre of the loop antenna was placed 1 meter above the ground, and the antenna polarization was changed. For maximizing emission at and above 30 MHz, the EUT was rotated through 360°, the antenna height was varied from 1 meter to 4 meters above the ground plane, and the antenna polarization was changed. This step by step procedure for maximizing emissions led to the data report in Exhibit 3.0.

The unit was operated standalone and placed in the center of the turntable.

Below 30MHz (Use Loop Antenna).

The equipment under test (EUT) was configured for testing in a typical fashion (as a customer would normally use it). The EUT was mounted to a plastic stand if necessary and placed on the wooden turntable, which enabled the engineer to maximize emissions through its placement in the three orthogonal axes.

2.2 EUT Exercising Software

There was no special software to exercise the device. Once the unit is powered up, it transmits the RF signal continuously.

2.3 Special Accessories

There are no special accessories necessary for compliance of this product.

2.4 Measurement Uncertainty

Decision Rule for compliance: For FCC/IC standard, the measured value must be within the limits of applicable standard without accounting for the measurement uncertainty. For EN/IEC/HKTA/HKTC standard, conformity rules will be used as per standard directly excepted EN/IEC 61000-3-2, EN/IEC 61000-3-3, HKTA1004, HKCA1008, HKTA1019, HKTA1020, HKTA1041 and HKTA1044.

2.5 Support Equipment List and Description

Not Applicable

TEST REPORT

3.0 EMISSION RESULTS

Data is included of the worst case configuration (the configuration which resulted in the highest emission levels). A sample calculation, configuration photographs and data tables of the emissions are included.

3.1 Field Strength Calculation

The field strength is calculated by adding the Antenna Factor and Cable Factor, and subtracting the Amplifier Gain (if any), Average Factor (optional) from the measured reading.

The basic equation with a sample calculation is as follows:

$$FS = RA + AF + CF - AG - AV$$

where

- FS = Field Strength in dB μ V/m
- RA = Receiver Amplitude (including preamplifier) in dB μ V
- AF = Antenna Factor in dB
- CF = Cable Attenuation Factor in dB
- AG = Amplifier Gain in dB
- AV = Average Factor in dB

In the following table(s), the reading shown on the data table reflects the preamplifier gain.

An example for the calculations in the following table is as follows:

$$FS = RR + LF$$

where

- FS = Field Strength in dB μ V/m
- RR = RA - AG - AV in dB μ V
- LF = CF + AF in dB

Assume a receiver reading of 52.0 dB μ V is obtained. The antenna factor of 7.4 dB and cable factor of 1.6 dB are added. The amplifier gain of 29.0 dB and average factor of 5.0 dB are subtracted, giving a field strength of 27.0 dB μ V/m. This value in dB μ V/m was converted to its corresponding level in μ V/m.

RA = 52.0 dB μ V/m	
AF = 7.4 dB	RR = 18.0 dB μ V
CF = 1.6 dB	LF = 9.0 dB
AG = 29.0 dB	
AV = 5.0 dB	
FS = RR + LF	
FS = 18 + 9 = 27 dB μ V/m	

Level in μ V/m = Common Antilogarithm [(27 dB μ V/m)/20] = 22.4 μ V/m

TEST REPORT

3.2 Radiated Emission Configuration Photograph

The worst case in radiated emission was found at 54.29038 MHz

For electronic filing, the worst case radiated emission configuration photographs are saved with filename: radiated photos.pdf.

3.3 Radiated Emission Data

The data on the following page lists the significant emission frequencies, the limit and the margin of compliance. Numbers with a minus sign are below the limit.

Judgment: Passed by 10.4 dB

TEST REPORT

RADIATED EMISSIONS

Model: 84994
Date of Test: April 22, 2024
Worst-Case Operating Mode: Transmitting

Table 1
Pursuant to FCC Part 15 Section 15.209 and 15.227 Requirement

Polarization	Frequency (MHz)	Reading (dBµV)	Pre-amp (dB)	Antenna Factor (dB)	Net at 3m (dBµV/m)	Limit at 3m (dBµV/m)	Margin (dB)
V	27.145	59.5	16	15.4	58.9	80.0	-21.1
V	54.290	34.6	16	11.0	29.6	40.0	-10.4
V	81.436	24.1	16	7.0	15.1	40.0	-24.9
V	108.581	17.2	16	14.0	15.2	43.5	-28.3
V	135.726	18.6	16	14.0	16.6	43.5	-26.9
H	162.952	15.3	16	16.0	15.3	43.5	-28.2
H	190.012	16.9	16	16.0	16.9	43.5	-26.6

- NOTES:
1. Peak Detector Data unless otherwise stated.
 2. All measurements were made at 3 meters.
 3. Negative value in the margin column shows emission below limit.
 4. Loop antenna is used for the emissions below 30MHz.
 5. Emissions within the restricted band meet the requirement of FCC Part 15 Section 15.205.
 6. Measurement Uncertainty is ±5.3dB at a level of confidence of 95%.

TEST REPORT

4.0 EQUIPMENT PHOTOGRAPHS

For electronic filing, the photographs are saved with filename: external photos.pdf and internal photos.pdf.

5.0 PRODUCT LABELLING

For electronics filing, the FCC ID label artwork and the label location are saved with filename: label.pdf.

6.0 TECHNICAL SPECIFICATIONS

For electronic filing, the block diagram and schematic of the tested EUT are saved with filename: block.pdf and circuit.pdf respectively.

7.0 INSTRUCTION MANUAL

For electronic filing, a preliminary copy of the Instruction Manual is saved with filename: manual.pdf.

This manual will be provided to the end-user with each unit sold/leased in the United States.

TEST REPORT

8.0 MISCELLANEOUS INFORMATION

The miscellaneous information includes details of the test procedure and measured bandwidth.

8.1 Radiated Emission on the Bandedge

The plot shows the fundamental emission is confined in the specified band. And it also shows that the emission is at least 33.5 dB below the carrier level at the band edge (26.96 and 27.28 MHz). It meets the requirement of Section 15.227(b).

Pursuant to FCC Part 15 Section 15.215(c), the 20dB bandwidth of the emission was contained within the frequency band designed (mentioned as above) which the EUT operated. The effects, if any, from frequency sweeping, frequency hopping, other modulation techniques and frequency stability over expected variations in temperature and supply voltage were considered.

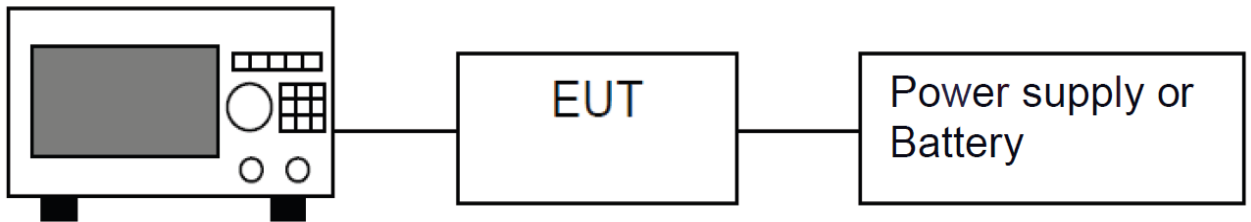

Spectrum Analyzer

Block diagram of Test setup

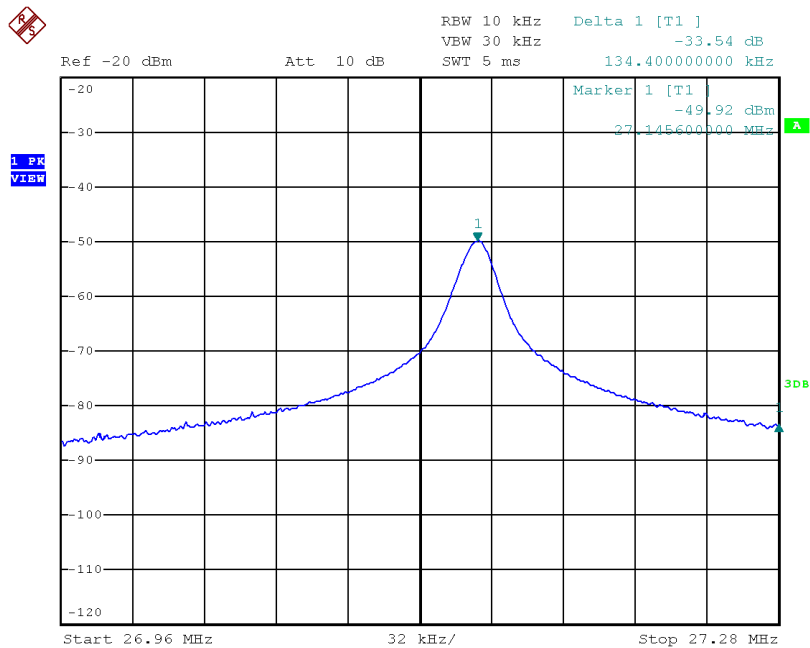

TEST REPORT

8.2 Emissions Test Procedures

The following is a description of the test procedure used by Intertek Testing Services Hong Kong Ltd. in the measurements of transmitter operating under the Part 15, Subpart C rules.

The transmitting equipment under test (EUT) is placed on a wooden turntable which is four feet in diameter and approximately 0.8m in height above the ground plane for emission measurement at or below 1GHz and 1.5m in height above the ground plane for emission measurement above 1GHz. During the radiated emissions test, the turntable is rotated and any cables leaving the EUT are manipulated to find the configuration resulting in maximum emissions. The EUT is adjusted through all three orthogonal axis to obtain maximum emission levels. The antenna height and polarization are also varied during the testing to search for maximum signal levels. The height of the antenna is varied from one to four meters.

Detector function for radiated emissions is in peak mode. Average readings, when required, are taken by measuring the duty cycle of the equipment under test and subtracting the corresponding amount in dB from the measured peak readings. A detailed description for the calculation of the average factor can be found in Exhibit 8.3.

The frequency range scanned is from the lowest radio frequency signal generated in the device which is greater than 9 kHz to the tenth harmonic of the highest fundamental frequency or 40 GHz, whichever is lower.

The EUT is warmed up for 15 minutes prior to the test.

AC power to the unit is varied from 85% to 115% nominal and variation in the fundamental emission field strength is recorded. If battery powered, a new, fully charged battery is used.

Conducted measurements were made as described in ANSI C63.10 (2013).

The IF bandwidth used for measurement of radiated signal strength was 100 kHz or greater when frequency is below 1000 MHz. Where pulsed transmissions of short enough pulse duration warrant, a greater bandwidth is selected according to the recommendations of Hewlett Packard Application Note 150-2. A discussion of whether pulse desensitivity is applicable to this unit is included in this report (See Exhibit 8.1). Above 1000 MHz, a resolution bandwidth of 1 MHz is used.

Transmitter measurements are normally conducted at a measurement distance of three meters. However, to assure low enough noise floor in the forbidden bands and above 1 GHz, signals are acquired at a distance of one meter or less. All measurements are extrapolated to three meters using inverse scaling, unless otherwise reported. Measurements taken at a closer distance are so marked.

TEST REPORT

4.2 Radiated Emission Test Setup

The figure below shows the test setup, which is utilized to make these measurements.

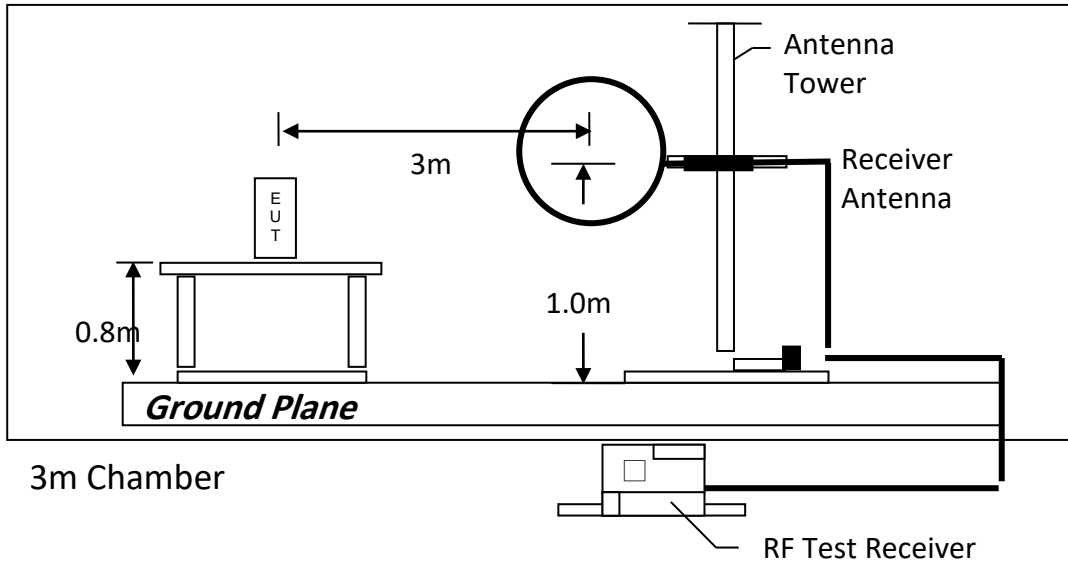

Test setup of radiated emissions up to 30MHz

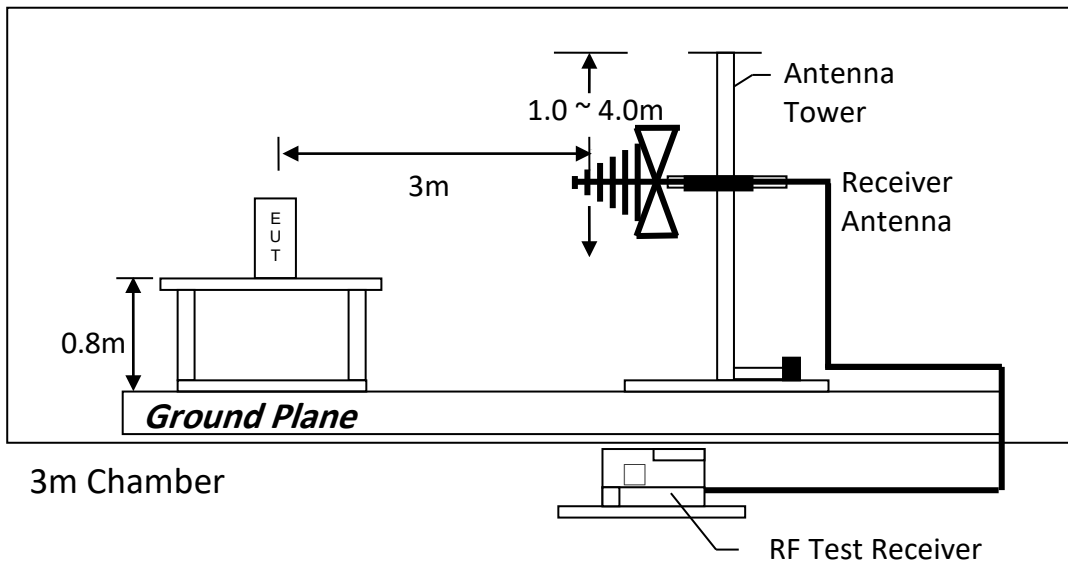

Test setup of radiated emissions up to 1GHz

TEST REPORT

8.3 Occupied Bandwidth

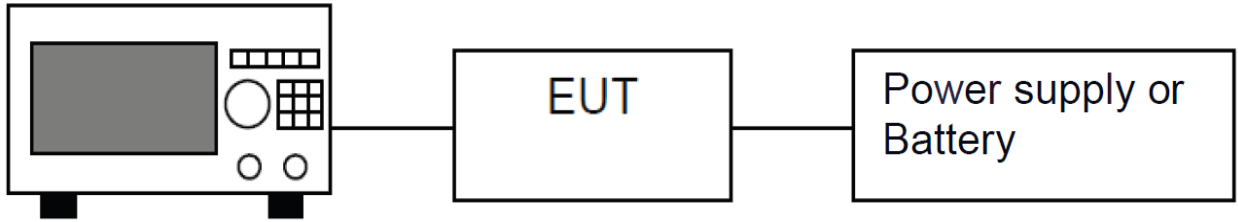

Spectrum Analyzer

Block diagram of Test setup

Occupied Bandwidth Results:

Frequency (MHz)	Occupied Bandwidth (kHz)
27.145MHz	13.952

The worst case is shown as below

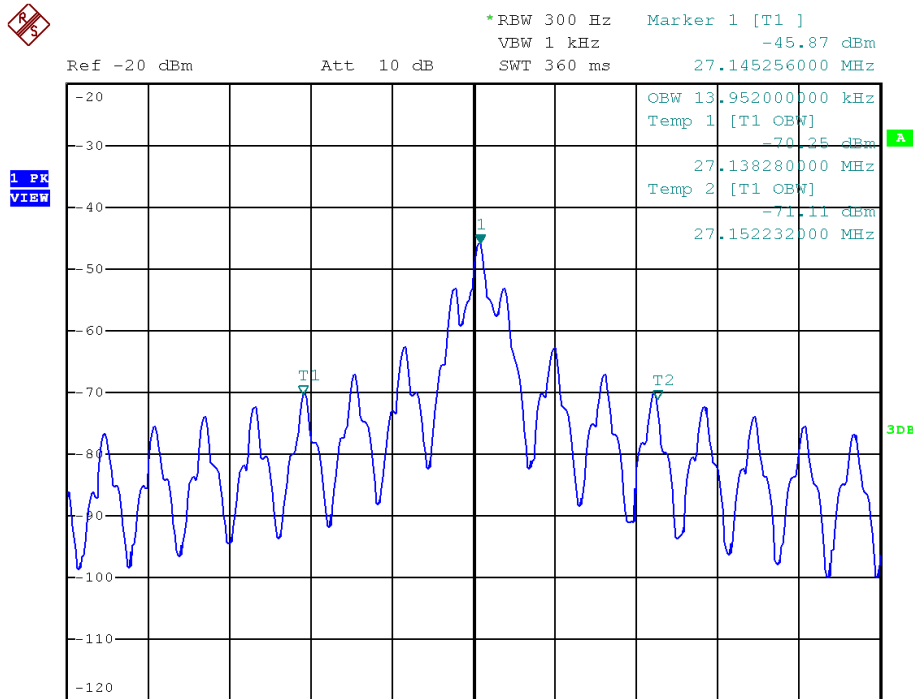

TEST REPORT

9.0 EQUIPMENT LIST

1) Radiated Emissions Test

Equipment	EMI Test Receiver (9kHz to 26.5GHz)	Biconical Antenna (30MHz to 300MHz)	Log Periodic Antenna
Registration No.	EW-3156	EW-3241	EW-3244
Manufacturer	ROHDESCHWARZ	EMCO	EMCO
Model No.	ESR26	3110C	3148B
Calibration Date	January 31, 2024	February 26, 2022	August 30, 2022
Calibration Due Date	January 31, 2025	May 26, 2024	May 30, 2024

Equipment	Double Ridged Guide Antenna (1GHz - 18GHz)	Active Loop Antenna (H-field) (9kHz to 30MHz)	RF Preampfier (9kHz to 6000MHz)
Registration No.	EW-0194	EW-3326	EW-3006b
Manufacturer	EMCO	EMCO	SCHWARZBECK
Model No.	3115	6502	BBV9718
Calibration Date	May 10, 2023	January 05, 2024	October 20, 2023
Calibration Due Date	November 10, 2024	July 05, 2025	October 20, 2024

Equipment	2.4GHz Notch Filter	14m Double Shield RF Cable (9kHz - 6GHz)	RF Cable 14m (1GHz to 26.5GHz)
Registration No.	EW-3435	EW-2376	EW-2781
Manufacturer	MICROWAVE	RADIALL	GREATBILLION
Model No.	N0324413	n m/br56/bnc m 14m	SMA m/SHF5MPU /SMA m ra14m,26G
Calibration Date	September 26, 2023	September 19, 2023	January 16, 2024
Calibration Due Date	September 26, 2024	September 19, 2024	January 16, 2025

Equipment	12 metre RF Cable (1-40)GHz	Pyramidal Horn Antenna
Registration No.	EW-2774	EW-0905
Manufacturer	GREATBILLION	EMCO
Model No.	SMA m-m ra 12m 40G outdoor	3160-09
Calibration Date	January 16, 2024	December 15, 2023
Calibration Due Date	January 16, 2025	June 15, 2025

TEST REPORT

2) Bandedge & OBW Measurement

Equipment	EMI Test Receiver (9kHz to 3GHz)
Registration No.	EW-3095
Manufacturer	ROHDESCHWARZ
Model No.	ESCI
Calibration Date	January 18, 2024
Calibration Due Date	January 18, 2025

3) Control Software for Radiated Emission

Software Information	
Software Name	EMC32
Manufacturer	ROHDESCHWARZ
Software version	10.50.40

END OF TEST REPORT